



## XIV ICFA Laboratory script

R. Bates<sup>1</sup>, L. Eklund<sup>1</sup> and I. Nasteva<sup>2</sup>

1. University of Glasgow, UK

2. UFRJ, Brazil

# Study of the characteristic X-ray spectra using silicon hybrid pixel detector

## Abstract

This experiment is designed to introduce a pixelated silicon state-of-the-art X-rays detection system developed at CERN as a spin-off development of the Large Hadron Collider (LHC). A basic understanding of semiconductor pixel detectors will be given by calibrating the detector with known X-ray sources and measuring spectrum from an <sup>241</sup>Am gamma source. A variety of software tools will be used for data acquisition, detector calibration and data analysis.

## Objectives

- Understand X-ray detection mechanisms in pixelated silicon detectors;
- Measure X-ray energy spectra from various x-ray sources;
- Gain practical skills in data acquisition using specialised program Pixelman;
- Practice data mining skills.

## Caution

This experiment involves the use of an X-rays source. Improper use could result in long term health consequences. The source should be handled with care. The Timepix detection system is fragile and very expensive. Please handle with care.



## General recommendations

Use folder "C:\TimepixLab\YourName\" to store any files. There are questions in the script highlighted with  sign. These are guide questions for discussion.

## TimePix detector

The hybrid pixel detector is one of several types of instrumentation currently available for X-ray precision measurement. **What other types of detectors do you know?** It comprises of a detection medium and readout electronics manufactured in different fabrication processes. Both parts of the detection system have a matching matrix of electrodes which are brought into contact via a process called flip-chip bonding (see Figure 1). **What other solid-state detectors apart from silicon are in use?** The Timepix detector used in this experiment is a novel development by CERN (see Figure 2). It comprises of 256x256 pixels each of 55x55  $\mu\text{m}^2$  that can operate in spectroscopic mode (Time-over-Threshold mode, known as ToT mode), where energy information is obtained at the same time as the position of interactions. **What other modes can this device run in?** The data is read out by the plug & play USB interface using the Pixelman software. **How does the ToT mode work? Discuss with the demonstrator.**

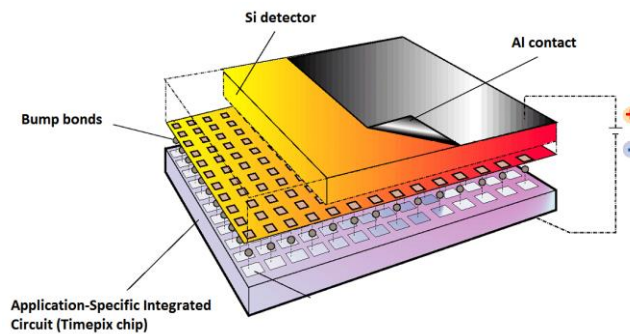

Figure 1 Hybrid pixel detector schematics

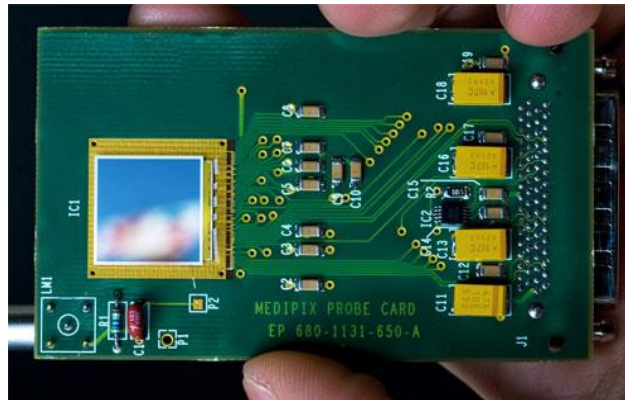

Figure 2 Timepix detector

## Experimental procedures

### Experimental setup

Figure 3 shows the diagram of the detection system used for this experiment. It consists of a various x-ray/gamma ray sources, (use the internet to find the energy of the x-ray lines of the sources during less busy times of the lab), a Timepix detector with USB interface and PC used for data acquisition. The USB interface has two connections. The LEMO cable provides DC bias to the silicon detector (+100V) from the USB interface. The USB cable powers the device and handles data acquisition.

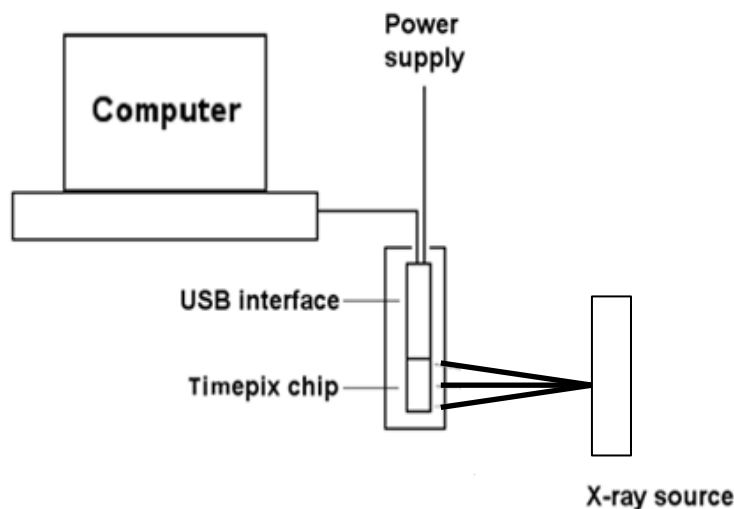

Figure 3 Characteristic X-rays spectra acquisition setup

### Setting up the detector

Run Pixelman program from the Desktop. Two windows should pop up, Medipix Control and Preview. The first one is used to control the parameters of data acquisition and setting up the sensor, the latter displays data. The software is user friendly and most of the options are self-explanatory.

Check that the bias on the detector is set correctly (**Medipix Control** → **Options** → **Device Settings** → **Interface Specific Info** tab). Check, that bias voltage is about 100 V (usually 94-98 V). Otherwise consult your demonstrator. *Why do you need to bias a silicon detector?*

Check that the ToT clocking frequency is set to 40 or 48 MHz (**Medipix Control** → **Options** → **Device Settings** → **Interface Specific Info** tab, set TimePix clock value to 2).

### Threshold equalisation

The Timepix sensor operates in a “noise-free” mode. The chip removes the electronic noise in the silicon detector system by setting an appropriate threshold (called THL in Pixelman), below which, the signal induced in the pixel is disregarded. The threshold needs to be adjusted per pixel with a per-pixel threshold adjustment bit. *Think, why would one need to equalise thresholds in different pixels?* Each pixel in the chip responds in a slightly different way to incident radiation due to transistor fabrication mismatches and non-uniformities of the detector. In order to obtain better and more uniform response, the narrowest possible distribution of pixel threshold levels across the chip has to be found. The procedure for threshold equalisation is described below. **It is recommended to**



perform this once a day to ensure uniform response of the chip. Think, what could happen on another day that affects the performance of the detector?

- Medipix Control** → File → Set Mode → Medipix
- Medipix Control** → File → Reset Pixel Cfg. → All Bits
- Medipix Control** → Tools → Threshold Equalization

A window similar to the one in Figure 4 will be displayed. Make sure that the parameter values on the left hand side of the window are as indicated.

**Press Start.** The plot on the right hand side should look similar to the one displayed on completion. If the distributions do not have Gaussian-like shape, it could be due to too much ambient light is incident on the detector. Cover it with black tape etc.



This procedure takes about 10 minutes. Discuss with each other and the demonstrator what is happening during this procedure. Look at the results window and try and understand what it is showing you.

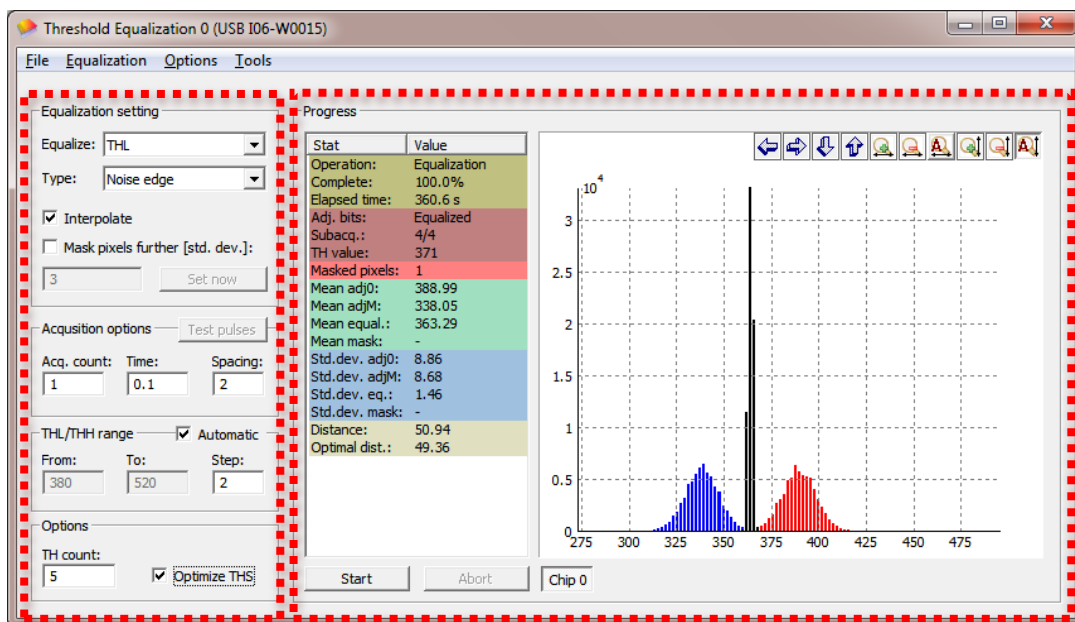

Figure 4 Threshold Equalization of the chip



**Medipix Control** → Tools → DAC Control Panel (see Figure 5)

The THL value is ambient temperature dependent, but should be around 350-380 ADC. *What do ADC and DAC stand for?* Set THL to about 20 units below the indicated value in Figure 5, e. g. if the displayed value is 363 ADC, set ~343 ADC.

Note that a lower THL value here implies a higher threshold valve.

Close DAC Control Panel window.

Close Threshold Equalization window.

In the Medipix Control window set

**Acquisition type Integral**

**Acquisition count 200**

**Acquisition time 0.1**

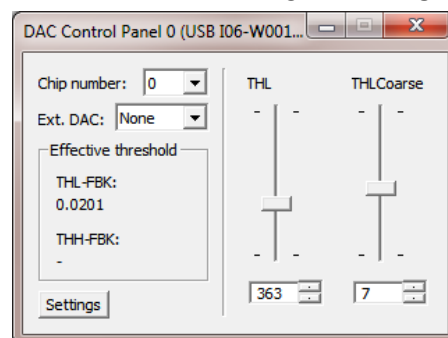

Figure 5 DAC control panel

**Press Start** to acquire data. In the Preview for Medipix Control window set Max Level 1. Some pixels will be shown in red, indicating an excessive (> 100) number of counts. These are to be excluded from further data acquisition.

If there are an excessive number of red pixels set the THL DAC level 5 lower.

Right click on the image area and select **Mask...** from the menu, enter 1 and press OK. These pixels now should be displayed in blue.

The setup is now ready for data acquisition. **Can noise pixels appear in the future? Why?**

## Time over Threshold (ToT) x-ray energy spectra

### Data acquisition

A photon of specific energy generates a number of electron – hole pairs in the detector. **What energy is required to generate an electron-hole pair in silicon for ionisation from high energy photons/particles?** These are collected by the pixels and converted into digital numbers. There is a relationship between incident photon energy and corresponding ADC value for a given detector.

In order to establish this relationship, spectra of known X-ray sources must be recorded. In this experiment characteristic photons from *a range of X-ray/gamma sources* (Am-241 and, Ba-133), an electron source (Cs-137) and a mixed alpha particle source will be used.

There is limited time for this laboratory and it is not expected that a full energy calibration will be possible. Data will be collected over the session to build up a more detailed graph. Your results of X-ray energy and ToT value should be added to the Calibration Graph spread sheet on the desktop.

It is important to look at the images collected in the Pixelman Preview window and at the spectra produced in the analysis section.

Place the source on top of the detector.

In the Pixelman software follow this procedure.

### Medipix Control → File → Set Mode → Time Over Threshold

Set Acquisition Control parameters as shown in Figure 6.

**Acq. type** Frames

**Acq. count** 2000

**Acq. time** 0.1

**Binary matrix**

**Single file**

**File output**

The file output should correspond to each target element to be recorded, e.g. for Ba target the path should look like

*"C:\TimepixLab\yourFolderName\Ba\_.tpx"*

**Press start.** In the Preview window interactions of

X-rays with the silicon sensor will be displayed and recorded. There are several options in the window available for better output data representation. Play around and figure out what they do.

Acquire data for **at least** one of the following sources: Am-241, Ba-133; and also for Cs-137 and a mixed alpha particle source.

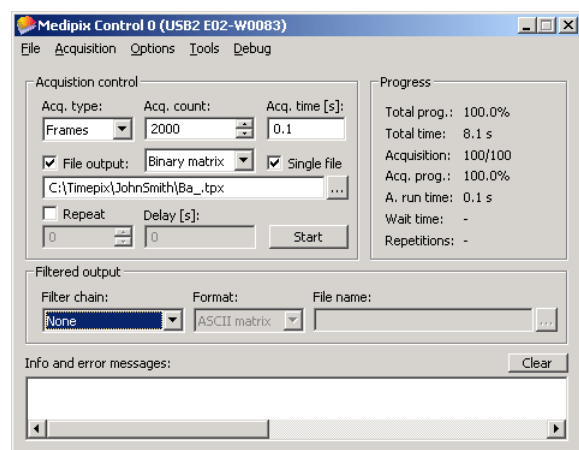

Figure 6 Medipix Control Panel



?

Why does the image on the Preview screen look so different for the Cs-137 source and the alpha source?

## Data analysis

Interaction of X-ray photons in the sensor is recorded in the form of digital units (ADC). These are converted into the incident photon energy utilising a *calibration curve*. Moreover, since the electron-hole cloud generated is of a finite size, sometimes interactions are recorded by several pixels simultaneously. The spread of charge between adjacent pixels has to be corrected in order to obtain the correct spectrum (this is called *clustering*).

A root script will be used to perform the data analysis from Pixelman.

Open root by clicking on the desktop icon.

Load the cluster analysis code (.L clusterAna.cpp)

To run the code read TimePix with the following input variable: your data file, number of events, debug:

```
readTimePix("../TimepixLab/yourFolderName/Ba_.tpx", 2000, false)
```

The code returns to screen the number of clusters found per frame.

When the analysis is finished a canvas appears that contains three graphs, the ToT (energy) spectra obtained for single pixel clusters, the energy spectra obtained for multi-pixel clusters and the cluster size distribution.

?

Think about the shape of the different spectra. Make a note of the peak(s) from the spectra and record this against the X-ray energy to form a calibration graph. Are there any peaks present in the multi-pixel clusters that are absent from the single pixel clusters, if so why? Why does the spectrum from the Cs-137 look so different to those from the other sources? Discuss your results among each other and with one of the demonstrators.

## Additional literature

1. Llopart X, Ballabriga R, Campbell M, Tlustos L, Wong W. Timepix, a 65k programmable pixel readout chip for arrival time, energy and/or photon counting measurements. *NIMA*. 2007, 581(1-2):485-494. DOI: [10.1016/j.nima.2007.08.079](https://doi.org/10.1016/j.nima.2007.08.079)
2. Jakubek J, Cejnarova A, Holy T, et al. Pixel detectors for imaging with heavy charged particles. *NIMA* 2008, 591(1):155-158. DOI: [10.1016/j.nima.2008.03.091](https://doi.org/10.1016/j.nima.2008.03.091)
3. Jakubek J. Semiconductor pixel detectors and their applications in life sciences. *Journal of Instrumentation*. 2009;4(03):P03013-P03013. DOI: [10.1088/1748-0221/4/03/P03013](https://doi.org/10.1088/1748-0221/4/03/P03013)
4. Jakubek J. Data processing and image reconstruction methods for pixel detectors, *NIMA*. 2007, 576(1):223-234. DOI: [10.1016/j.nima.2007.01.157](https://doi.org/10.1016/j.nima.2007.01.157)
5. Glenn K. Knoll, Radiation Detection and Measurement, 3<sup>rd</sup> edition, John Wiley and Sons, 1999, Chapter 2 (III), Chapter 11.
6. Frank H. Attix and William C. Roesch (1968), Radiation Dosimetry, 2nd ed., Academic Press, 95.
7. Max Born (1989), *Atomic Physics*, 8th ed., New York: Dover Publications, 126-127.
8. G. P. Harnwell and J. J. Livingood (1933), *Experimental Atomic Physics*, 1<sup>st</sup> ed., McGraw-Hill Book company, 363-365.
9. J. C. Willmott (1975), *Atomic Physics*, John Wiley & Sons Ltd., 324-328.



# Silicon Detectors Laboratory TimePix X-rays



2017

## Other relevant sources of information

1. Timepix chip <http://www.cern.ch/MEDIPIX>
2. Pixelman software <http://aladdin.utef.cvut.cz/ofat/others/Pixelman/Pixelman.html>
3. Periodic table elements fluorescence X-ray energies <http://xdb.lbl.gov/>