

Welcome to the 1st TWIIS workshop in Berlin 28-30 Aug 2017

Topical Workshop on Injection and Injection Systems

27-30 August 2017
Bessy II Berlin
Europe/Zurich timezone



Overview

Timetable

Contribution List

Registration

Accommodation

Venue + Travel

Participant List

We are pleased to announce that the first Topical Workshop on Injection and Injection systems will be organized by HZB (BESSY II) on the 28th-30th August 2017 as a sub-series of **Ring for Low Emittance (RULE)** workshops within the newly EU funded **ARIES** programme (Accelerator Research and Innovation for European Science and Society).

The aim of the workshop is to bring together experts from the scientific community working on Injection and Injections Systems for ultra-low emittance machines, including light source storage rings, damping rings, and future e⁺/e⁻ circular colliders.

A strong R&D effort has been ongoing in the optimisation of the beam dynamics of such



RULE workshop series

The workshop series was initiated by the joint ILC/CLIC damping ring working group it has been supported by the **EuCARD2 project (2013-17)** and is now supported by the **ARIES project (2017-20)**

Network activities putting together three communities
damping rings + lepton colliders + light sources

to discuss common issues in the design, realisation and operation of
low emittance rings

Charge and objectives

- **Share info about current programmes** on low emittance rings
 - Share info about **main issues/problems** in
Accelerator Physics, LER technology
Discuss and **get feedback on proposed solutions**
 - Identify and prioritise **R&D**
 - **Identify and fostering collaborations**
- (large focus on applications compared to Lowεring)

Lowering workshop series

EuCARD2 – Workpackage Lowering

- 4 general workshops (~80 delegates)
Oxford (2013) Frascati (2014) Grenoble (2015) Paris (2016)
- 6 topical workshop (40-80 delegates)
 - 2 on Collective effects – SOLEIL (2014), Diamond (2016)
 - 2 Technology – IFIC Valencia (2014) ELETTRA (2016)
 - 2 Beam dynamics – ALBA (2015), MAX IV (2016)

ARIES – Workpackage RULε

**1st Topical workshop on injection and ineciton systems
in Berlin, UK this round (~50 delegates)**

Workshop organisation

Experience with existing machines

Novel Injection Scheme

Novel Injection Scheme

R&D

R&D

Reports

Monday morning

Monday afternoon

Tuesday morning

Tuesday afternoon

Wednesday morning

Wednesday afternoon

Session chairs

M. Ries, M. Aiba, J. Holma, R. Bartolini, P. Kuske,

ARIES requires a written report on the main discussions of the workshop

Injection key issues (...selected)

- **Accelerator Physics**
Light Source and new colliders use Top-Up → Top-Up transient causes (power supply, coating,)
remedies (better PS, better coating, compensation kickers, ...)
Injection in small DA for pushed lattices
- **Novel injection scheme**
Longitudinal injection, Antiseptum
Non linear kickers, Swap-out injection
...
- **R&D**
new hardware, stripline, fast pulsers, inductive adders
coatings, instrumentation
what collaboration can be fostered with RUL ϵ
how can we engage with industries?

Setting the scene: R&D on injection for Diamond and Diamond II

R. Bartolini

*Diamond Light Source
and
John Adams Institute, University of Oxford*

Outline

Injection at Diamond

Layout

Operational issues

Top-Up transient: analysis and remedies (WIP)

Injection at Diamond II

Constraints and design

Injection in reduced DA: planned R&D

Ongoing work and conclusions

Diamond injection

Four kickers bump in one straight sections (8.3 m flange-to-flange)
2007-15: septum at -16mm and injection point at -8.3 mm

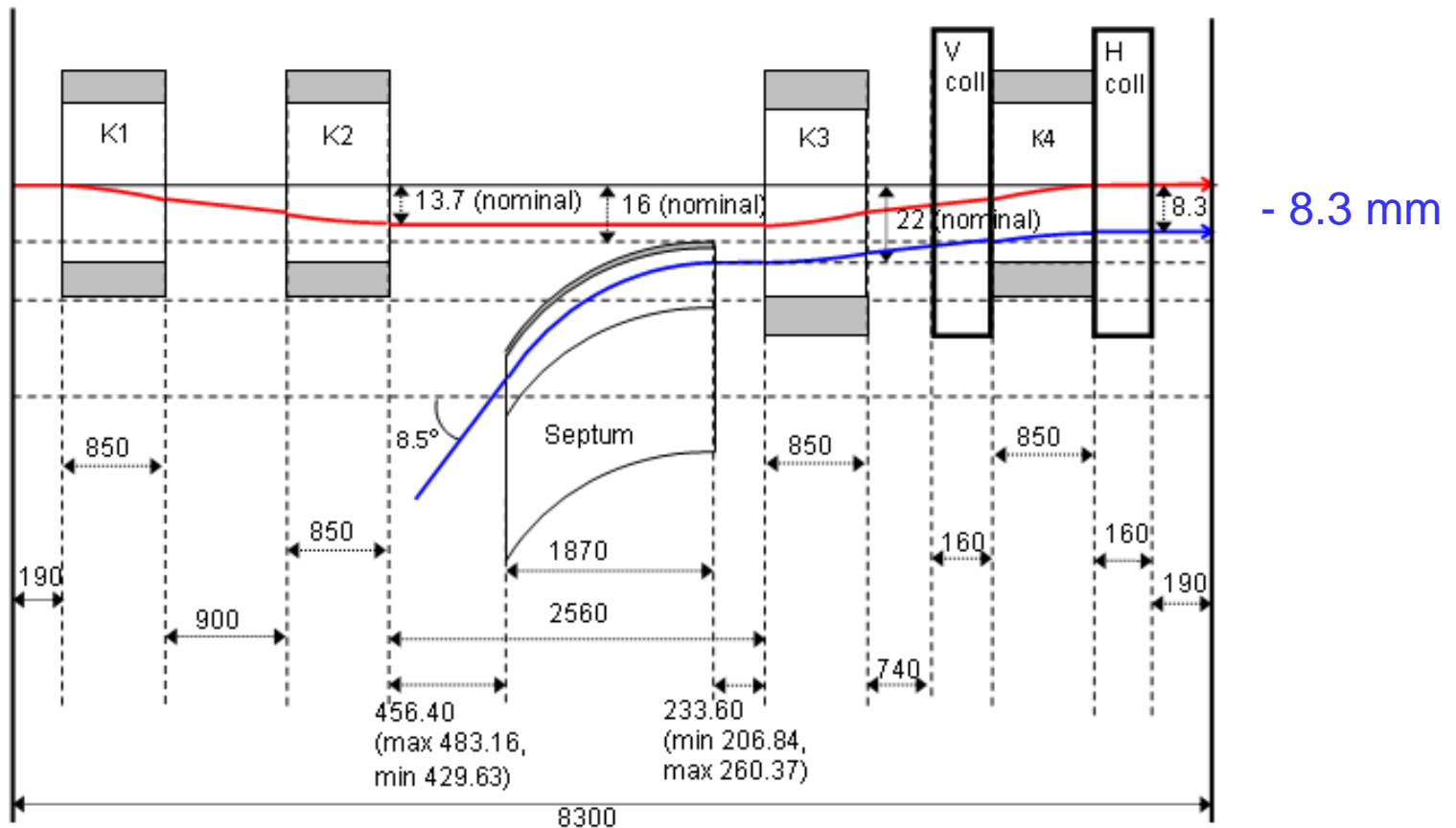

2015-now septum moved at -12 mm to have the injection point at -6.5 mm and lower the strength of the kicker bump

Kickers assembly overview

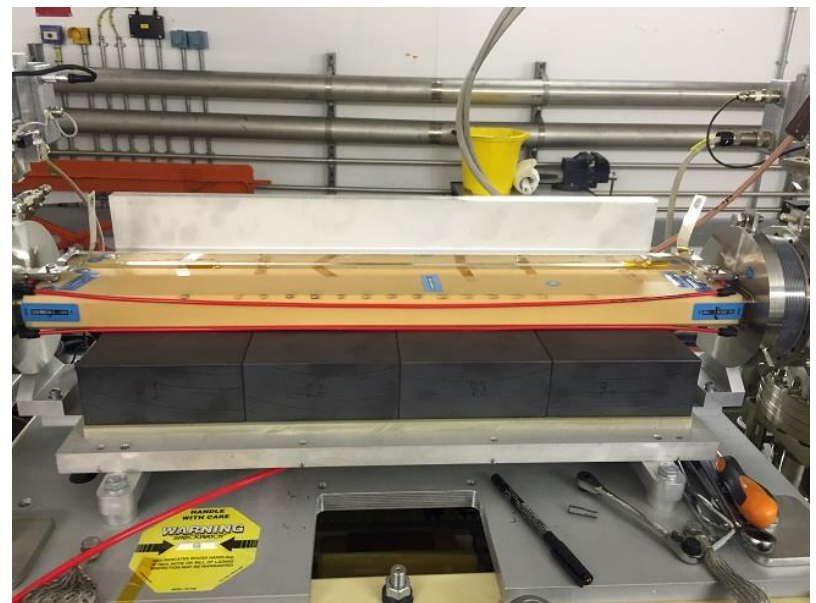
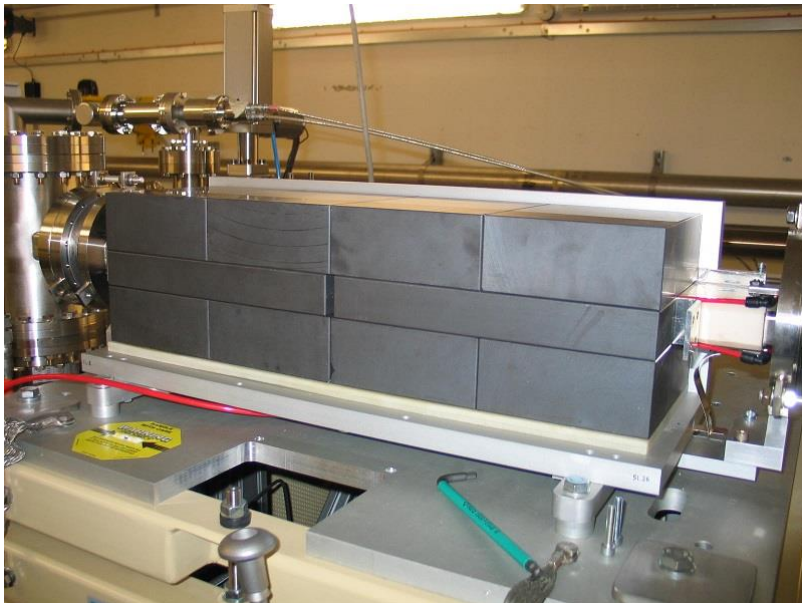
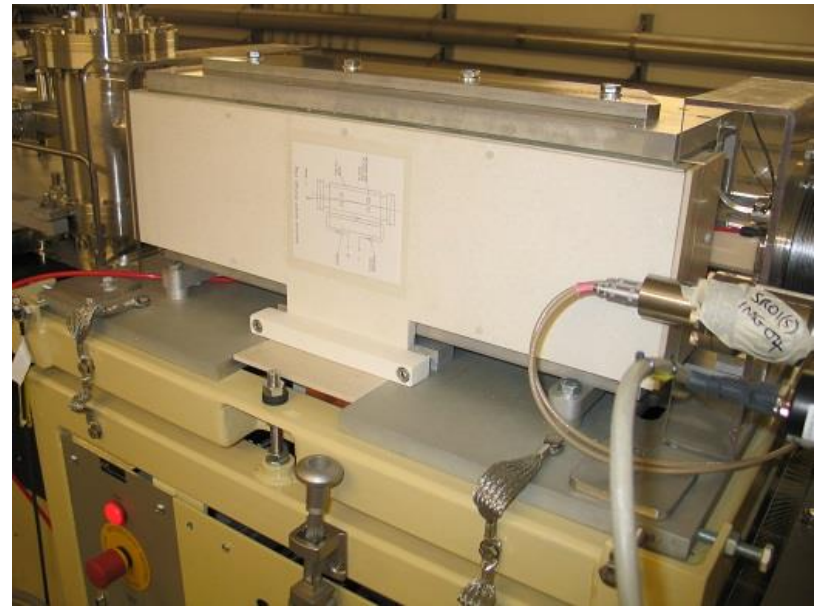

SR septum (Danfysik)

Type	active septum, ex-vacuum
Beam deflection angle	8.5 degrees
Physical length (mm)	1870
Magnetic length (mm)	1694
Nominal magnet field strength (T)	0.894
Peak magnet field strength (T)	1.07
Septum thickness (mm)	2.9
Nominal septum position (from circulating beam axis) mm	16
Range of septum positions (mm)	11.9-19.9
Good field aperture, HxV (mm)	12 x +/- 5
Magnetic field homogeneity in good field aperture	10-3
Leakage field at beam orbit (mTm)	< 30
Power Supply Parameters:	
Current waveform	Full cycle sine 400 μ s period
Peak current (kA)	15.3
Peak voltage (V)	550
Repeatability of peak I (%)	\pm 0.05
Jitter on peak current time (ns)	< +/- 50
Repetition rate (Hz)	5

Danfysik
400 μ s pulse
11.6 kA

SR kickers (Danfysik)

Type	ex-vacuum, ceramic vessel	
Nominal beam deflection angle (mrad)	9.54	Danfysik
Max. beam deflection angle (mrad)	10.1	
Physical length (mm)	850	
Magnetic length (mm)	600	5 us pulse (half-sine)
Nominal magnet field strength (T)	0.16	
Maximum magnet field strength (T)	0.192	
Metallic coating material, thickness	Titanium, 0.6 μm	2.74 kA
Variation of coating resistance	< 10 %	Nominal Ti coating 600 nm
Magnet good field aperture, HxV (mm)	$\pm 25 \times \pm 9$	
Magnetic field homogeneity in good field aperture	10-3	
Vacuum vessel internal dimensions, HxV (mm)	80 x 23	
Vacuum vessel wall thickness (mm)	5	
Magnet poles clearance to ceramic chamber (mm)	2	
Magnet aperture, HxV (mm)	94 x 37	

Power Supply Parameters:	
Current waveform	Half sine wave, 5 μs duration
Current rise time (μs)	2.5
Current fall time (μs)	2.5
Peak current (kA)	5.7
Peak voltage (V)	8.5
Repeatability of peak I (%)	+/- 0.5
Jitter on peak current time (ns)	+/- 5
Repetition rate (Hz)	5

- + tune kickers for tune, DA and FM measurements
- built in-house; same vacuum vessel same coating
- 2 mrad kicks ~3.5 us pulse: much less than injection kickers

Kickers vessel overview

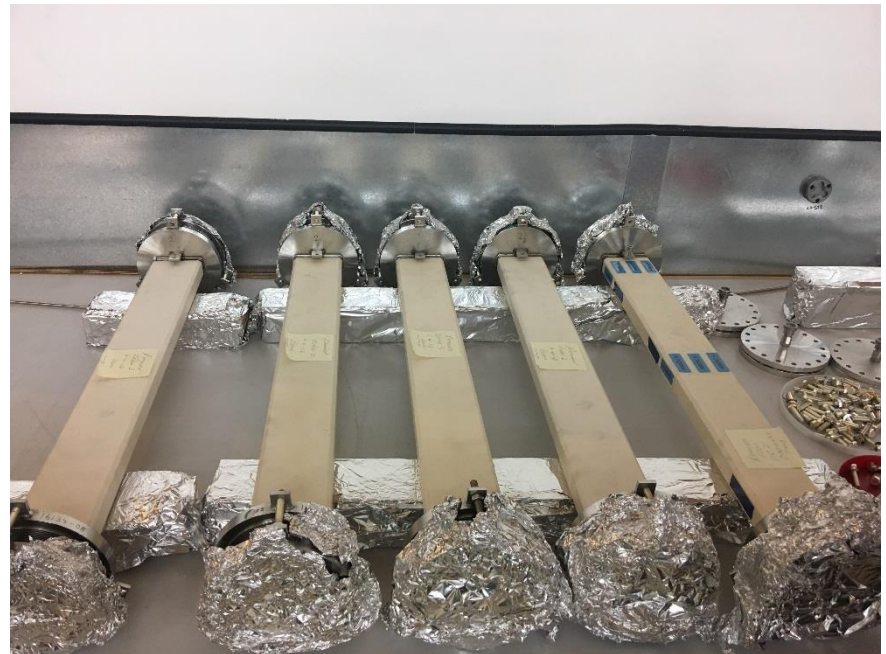
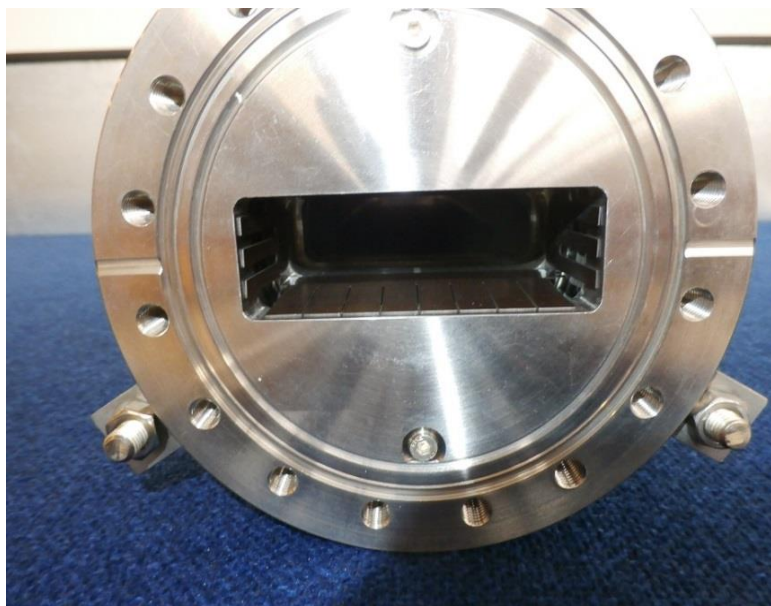
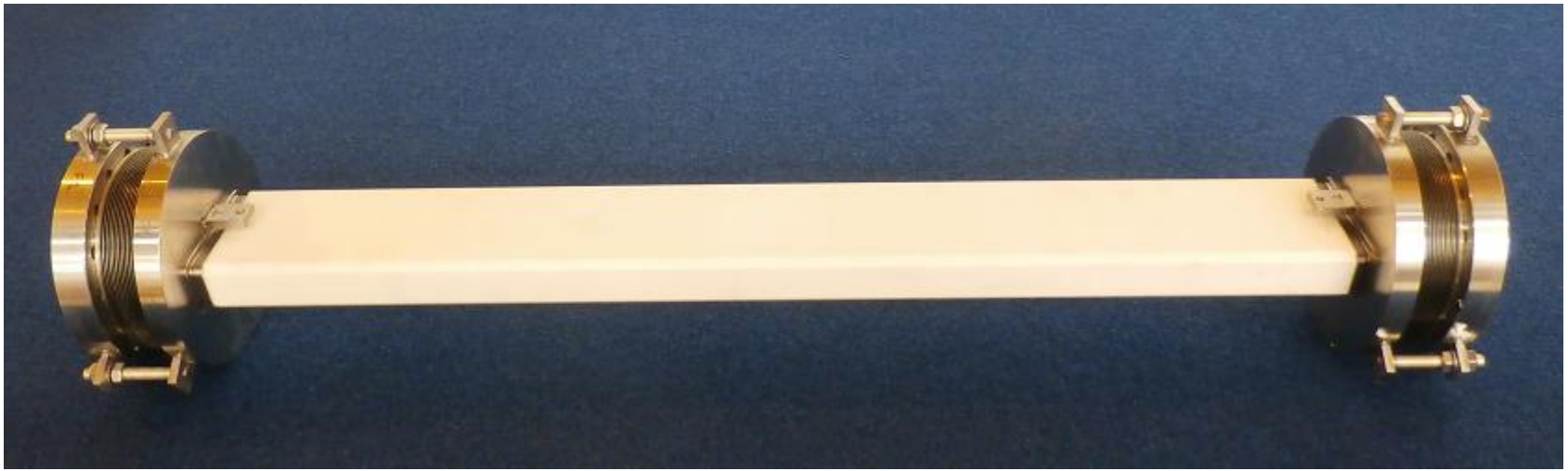

Top-Up injection cycle

Flexible top up programme, usually operated every 10 minutes with ~ 20 shots or more – current stability few 10^{-3}

Injection efficiency 70-80% (all IDs closed) ~85% with IDs open
Residual orbit perturbation never been better than 150 μm p-t-p

Four kickers seem unmatchable !

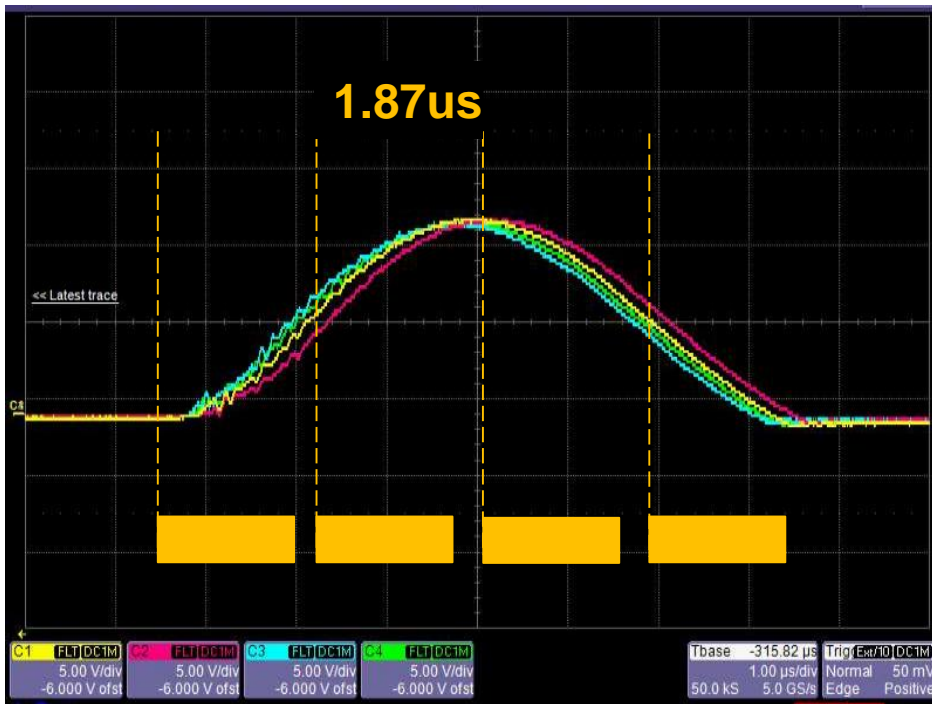

- the stored beam is kicked at least three times
- aligning current traces on scope produced very poor injection efficiency
- best injection efficiency requires shift of kicker 2 timing (magenta)
- virtually impossible to match the pulses over the full train

 means 900/936 fill

Injection transient during Top-Up

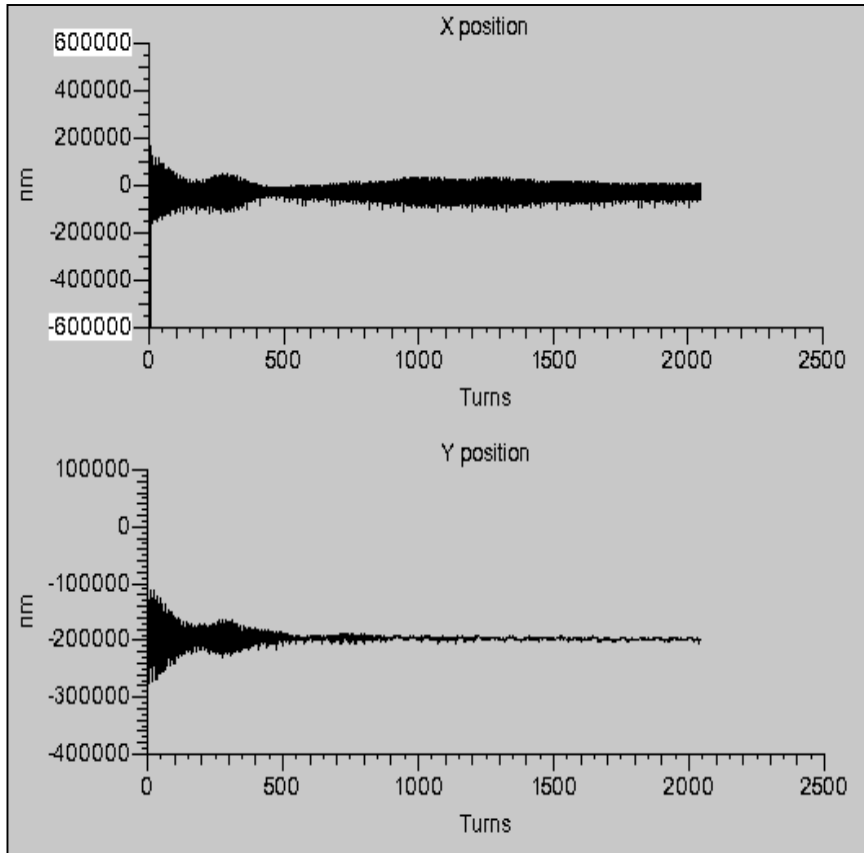

- Kicker induced orbit transient at diagnostic BPM:

 - +/- 150 μm horizontal p.t.p

 - +/- 75 μm vertical

- best achieved since 2011

- Septum produces no significant effect

- Gating signals supplied to beamlines

- No complaints so far from transient at injection, users seem happy, but IR (and others..) beamlines have yet to come. ...in 2011

The problem

Transient clearly visible by the beamline

Gating offered to users,
however not an ideal solution

- Long time experiments (long scans, B22 FTIR spectra). Beamlines can chop the scan (when top-up cycle is coming) and repeat or stop/resume
- Beamlines can renormalise the results with the knowledge of the intensity fluctuations, but not all beamlines measure the intensity

With beamlines optics, detectors and techniques ever improving, transparent injection is becoming a MUST

It was specifically included as a deliverable in the 10-years vision document for Diamond 2015-2025

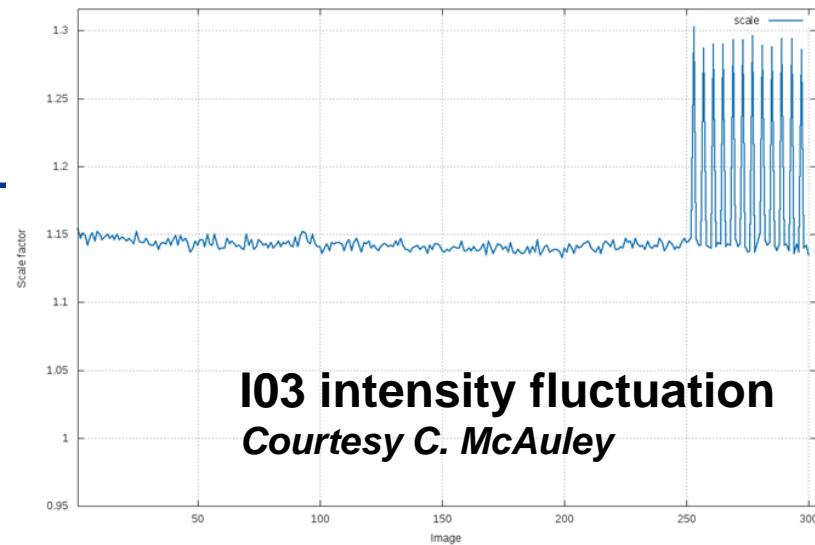

Injection analysis and optimisation

Can we reduce the injection transient?

Optimisation

- maximise injection efficiency
- reducing top up transient

Diagnostics

- turn-by-turn data and TMBF (bunch by bunch, turn by turn data)

Adjusting

- amplitude and timing of each individual kickers
- orbit bumps in the injection straight
- transfer line setting (trajectory and optics)

and in parallel

Magnetic/thermal models

Measurements on test stand or with beam

Analysis of the effect of kicker coating

Novel hardware e.g. compensation kickers, NLK

Injection analysis and optimisation

Increasing the amplitude of the kicker bump brings orbit closer to the injected beam

- inside the dynamic aperture
- until the stored beam scrapes the back of the septum

Initial position and angle of the injected beam can be computed from the first turn trajectory (RF off i.e. only injected beam)

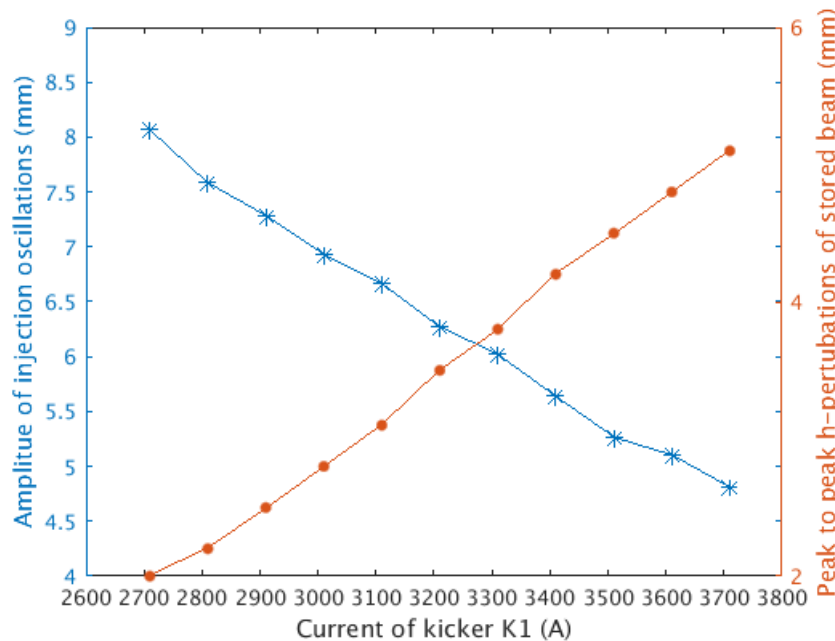

Operation value is 2740 A → 8.3 mm (8.1 mm reconstructed)

However stored beam oscillation increase with kicker current and stored beam start scraping the septum beyond 3.7 kA

Good injection efficiency often obtained with non-optimal residual kick

Further operational issues

Heating of vacuum chamber (50-60 deg) required additional cooling
Ti coating to reduce RW impedance
deposited heat via eddy current (pulsed magnetic field)
deposited heat via resistive wall impedance (beam)
coating thickness: uniformity, stability,

Erratic behaviour with swapping of ceramic chambers:

- We have operated 7 years with a set of kickers that were known to have coating defects (Danfysik sputtered coating)
- Installed new set of vessel with (allegedly) better coating (electrochemical deposition by PMB)
- One kicker failed after few hours of full current beam: vacuum bursts trip beam – occurring only when pulsing the magnet
- Suspect mechanisms: weakness in coating adherence + heating → flaking and further heating → arcs → vacuum events (signs of arcing seen at the ends of the vessel e.g. spoiled coating)
- Reinstalled old vessels (even if one vessel coating is open $R=\infty$)

Kicker vessel coating damage

Existing kickers coating and tune kicker coating
coating damage appears at the ends

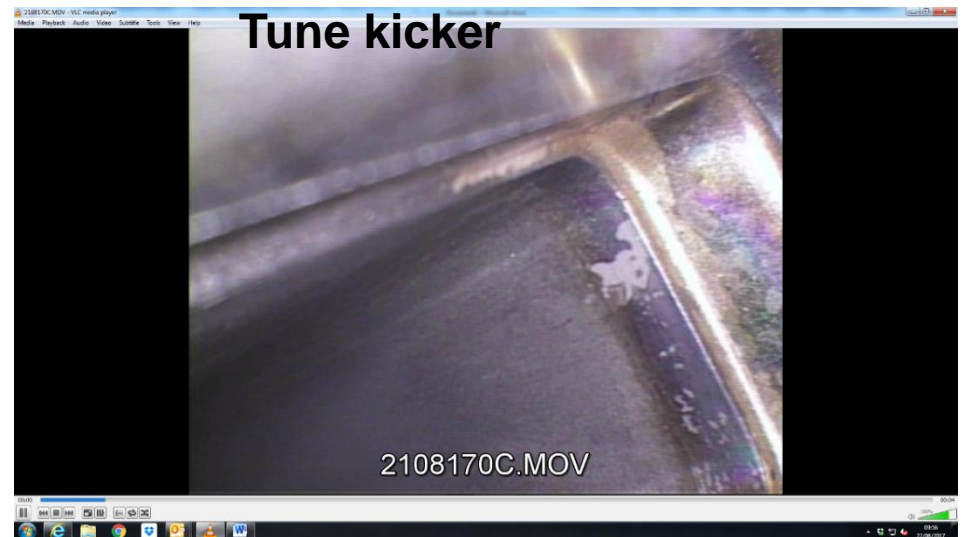
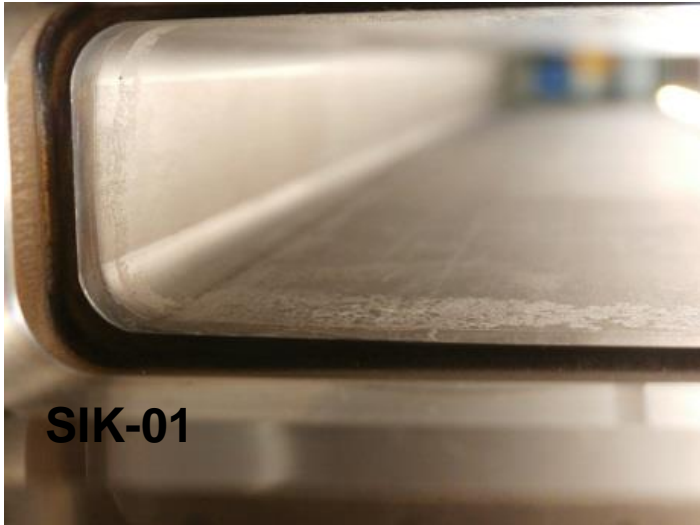

Investigating coating uniformity

4-Point Probe setup

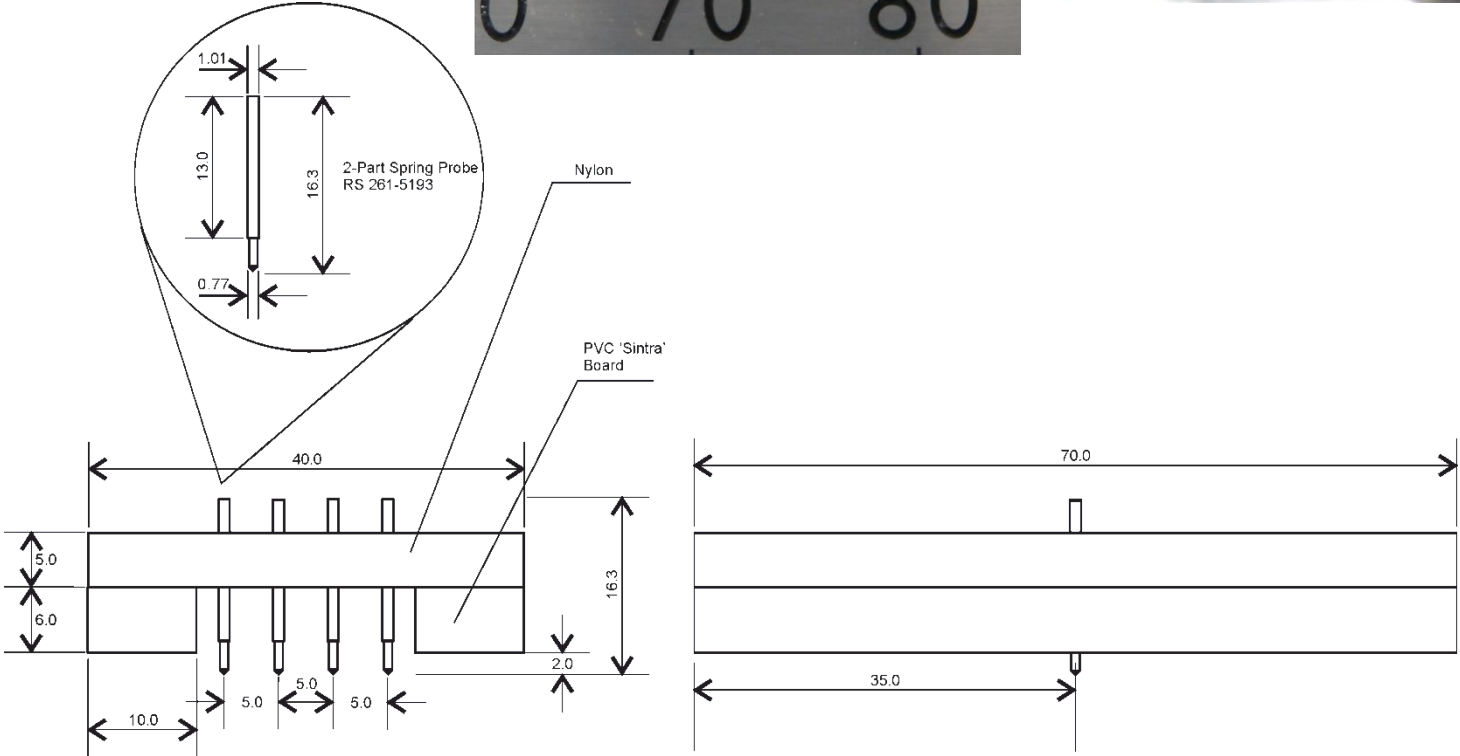
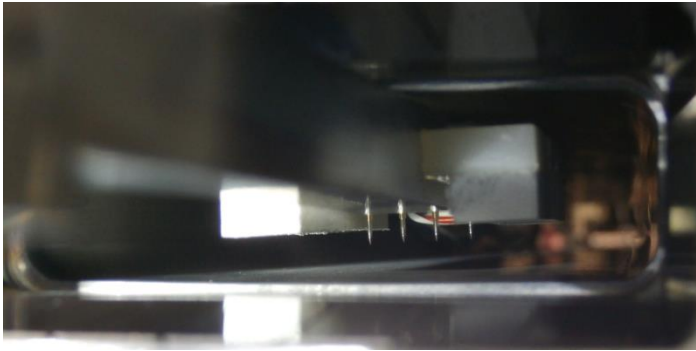
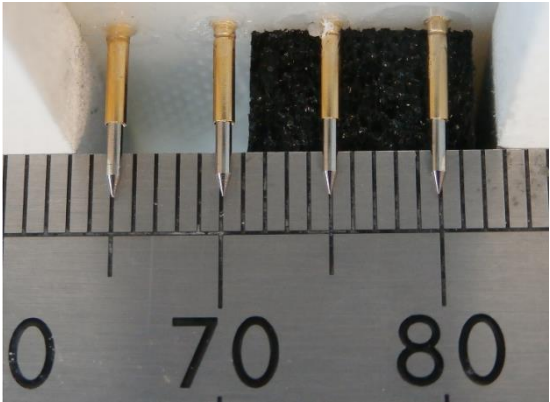

Coating thickness measurements (SIK-01)

SIK-01 Bottom Surface

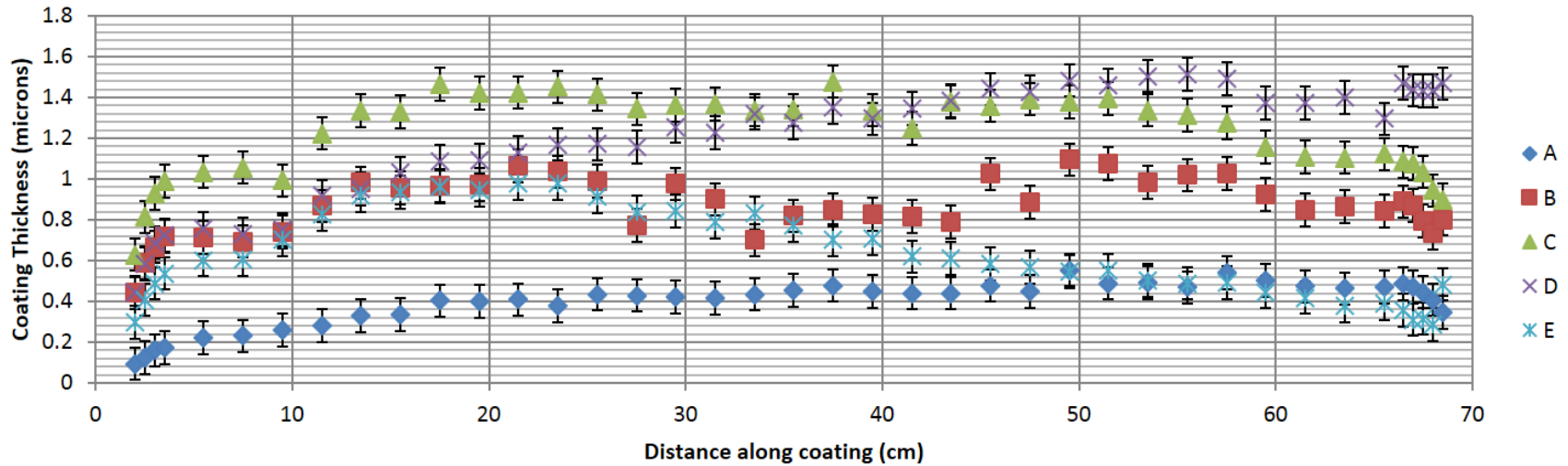

SIK-01 Bottom Surface

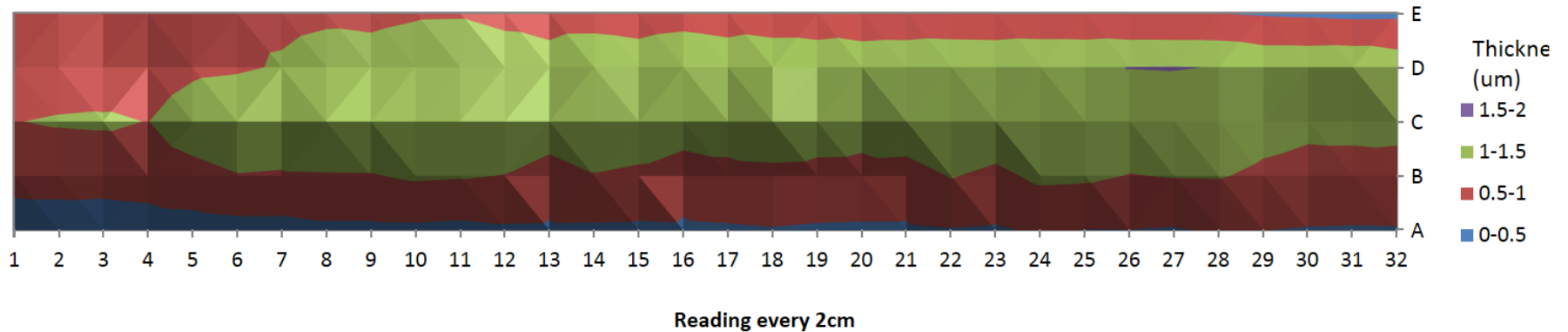

Coating thickness measurements (SIK-01)

SIK-01 Top Surface

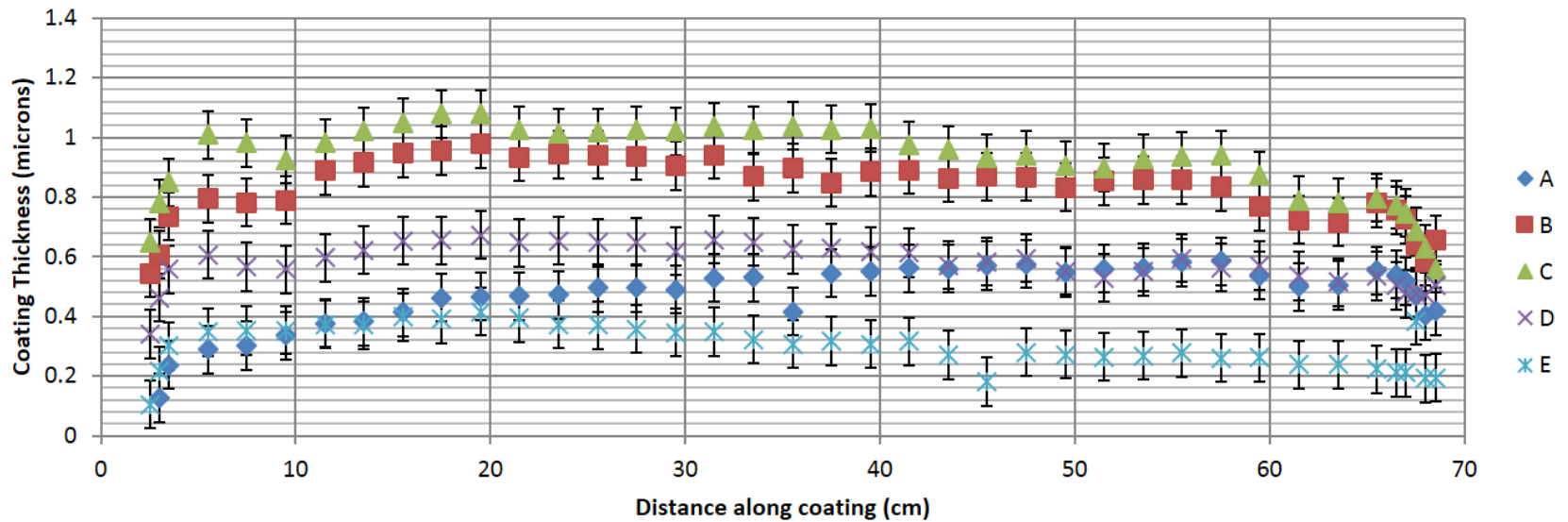

SIK-01 Top Surface

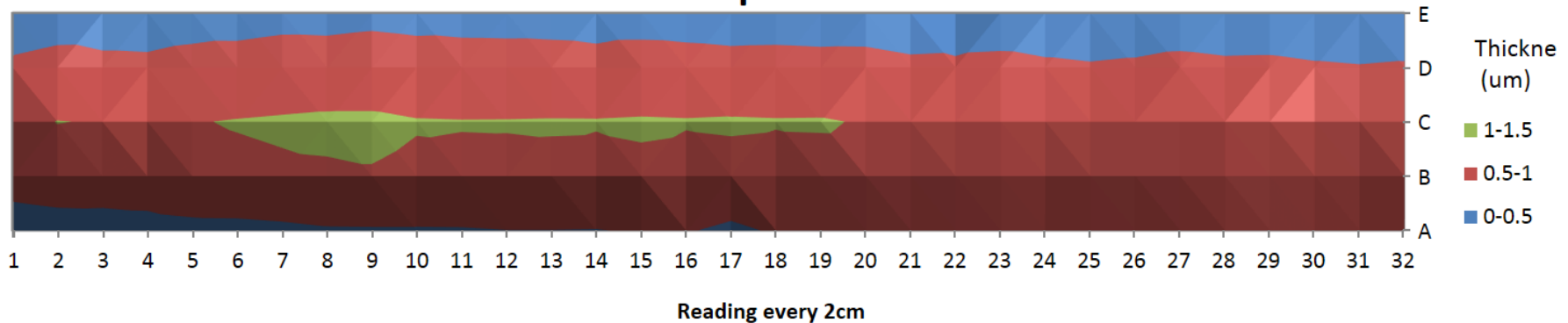

Coating thickness from resistance flange-to-flange

Infer the thickness of the coating using $t = \rho * L / (R * W)$, where ρ is the bulk resistivity of the material ($\rho_{Ti} = 4.2 \cdot 10^{-7} \Omega m$), L is the length of the ceramic chamber ($L = 0.7 m$), W is the perimeter of the cross section ($W = 2(a+b) = 0.212m$) and R is the measured resistance flange to flange

Old vessels (currently installed) Aug. 2015

Kicker	R [Ω]	Ti thickness [μm]
1	3.6	0.39
2	open	-
3	3.7	0.38
4	4.4	0.32
Diagnostic vessel	4.6	0.30

New vessels (before installation) Apr. 2016

Kicker	R [Ω]	Ti thickness [μm]
1	3.29	0.42
2	3.22	0.43
3	3.37	0.41
4	2.90	0.48

New kickers (after installation)

Kicker	R [Ω]	Ti thickness [μm]
1	7.6E+04	2.3E-05
2	3	0.46
3	3.3E+04	5.4E-05
4	3	0.46

Average thickness for 4 old kickers = 0.36 μm

For new kickers before install. = 0.44 μm

Kicker time dependent simulation with OPERA2D/3D

Kicker cross section:

C magnet with one turn; Ferrite yoke with precision blocks

The return conductor runs down the back (left hand side)

The eddy current shield gives uniform field across the gap

Shield design keeps the inductance low (ease pulsed power supply and the construction as the turn do not cross the aperture)

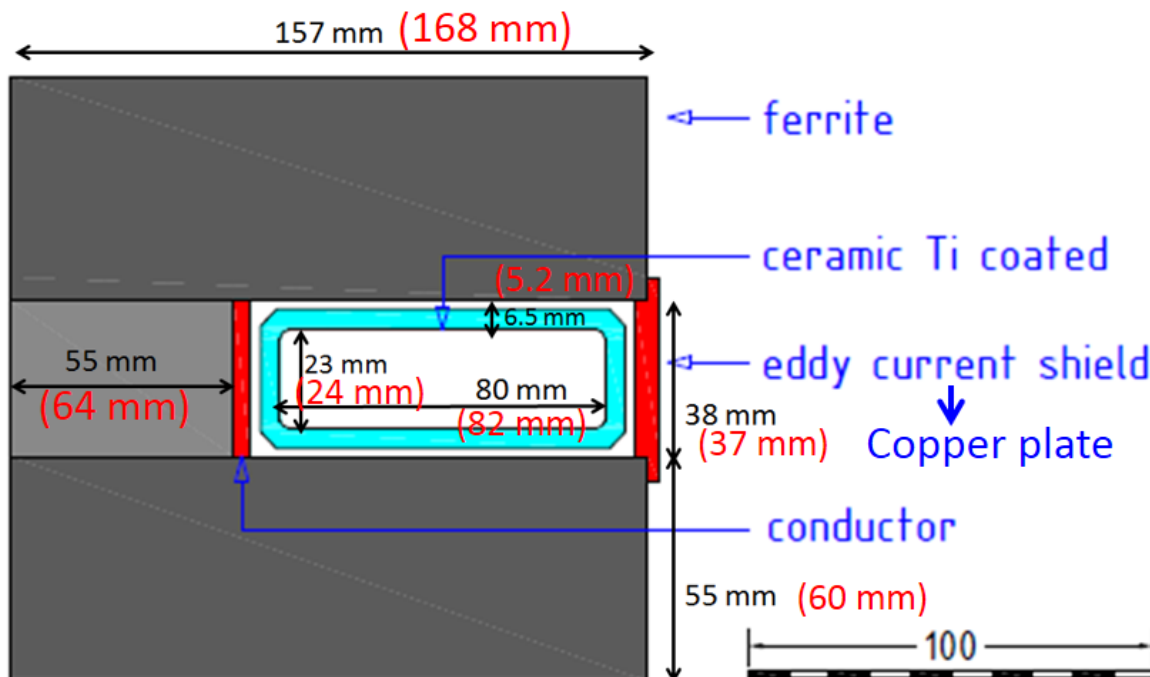

Design very similar to kickers at ALBA

data:

Diamond (red)

ALBA (black)

Kicker time dependent simulations with OPERA2D/3D

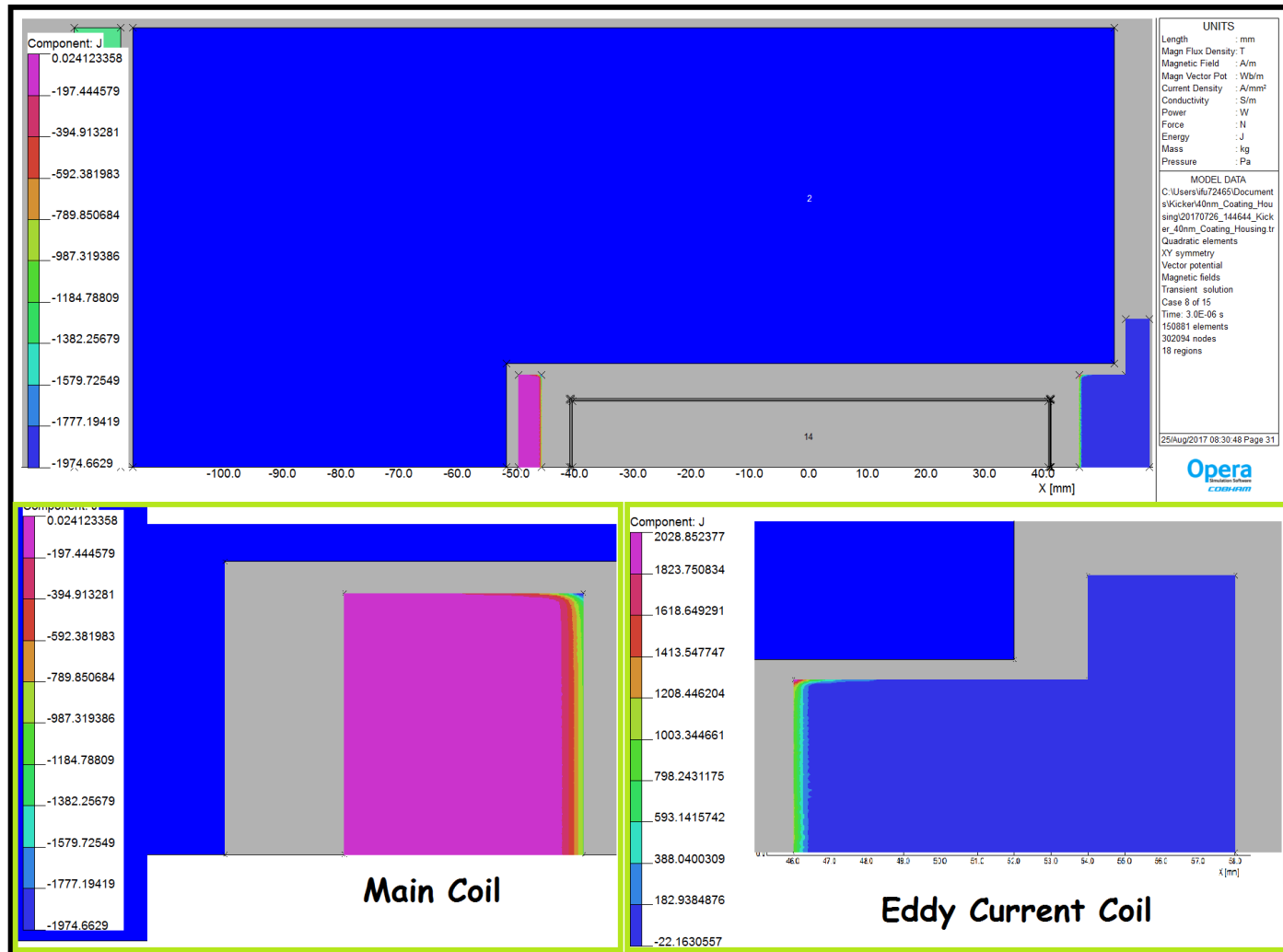

Proximity effect on coils: the current flows on the inner side of the conductor in a skin depth length; the shield is grounded and carries the same (opposite) current

Current distribution in the coating OPERA2D/3D

Example eddy current in a rectangular metallic pipe

eddy current flows on the sides and changes sign at the peak of the pulse
 → B_{dot} ; beam image currents flows at the centre

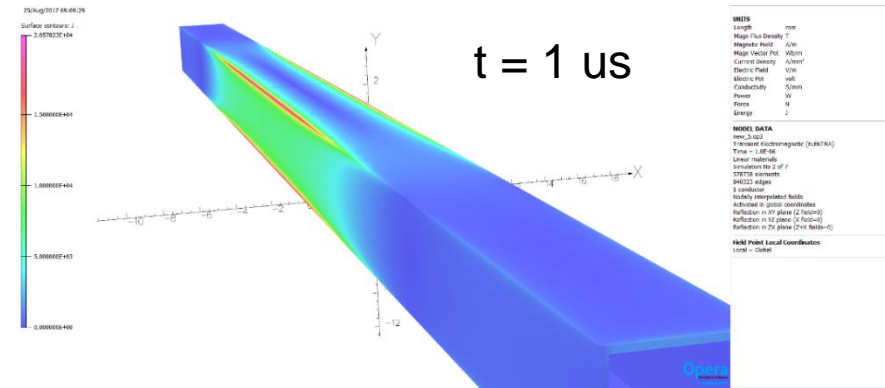

Eddy currents in the 1um Ti coating sheet (6 us pulse)

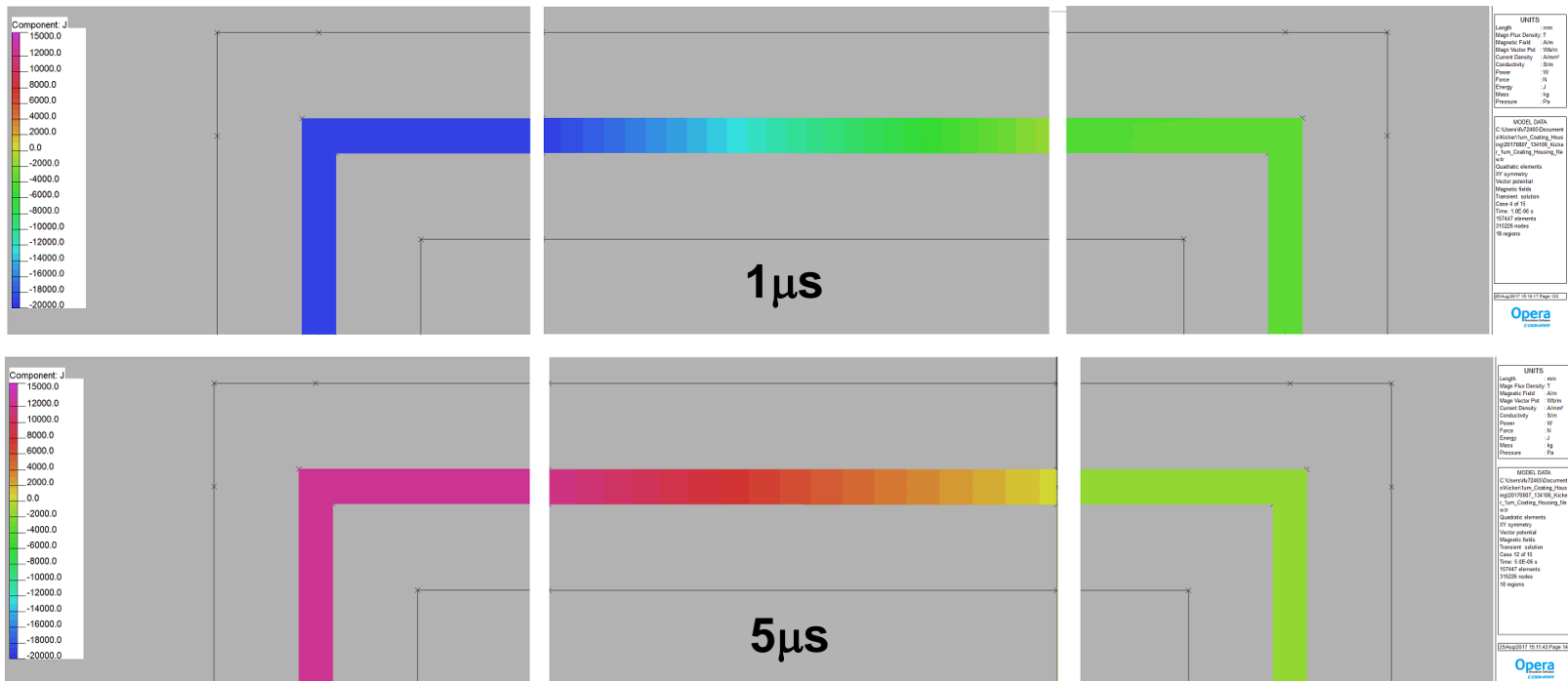

Kicker time dependent simulation with OPERA2D/3D

**Effect of coating thickness:
simplified circuit C discharge
(not the actual pulse)**

**Main dipole attenuated and shifted
40/200/1000/5000 nm thickness**

**b_2 and b_3 components appear and
change sign during the pulse**

C-shaped yoke kicker

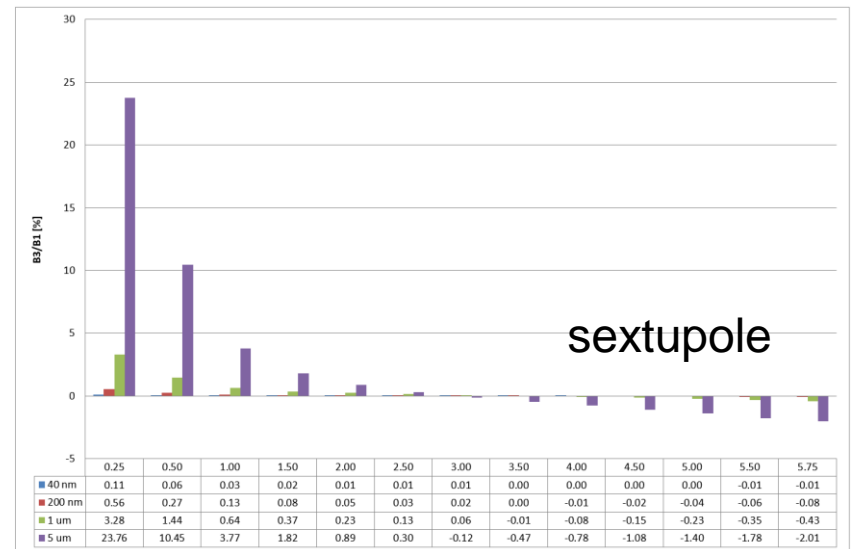
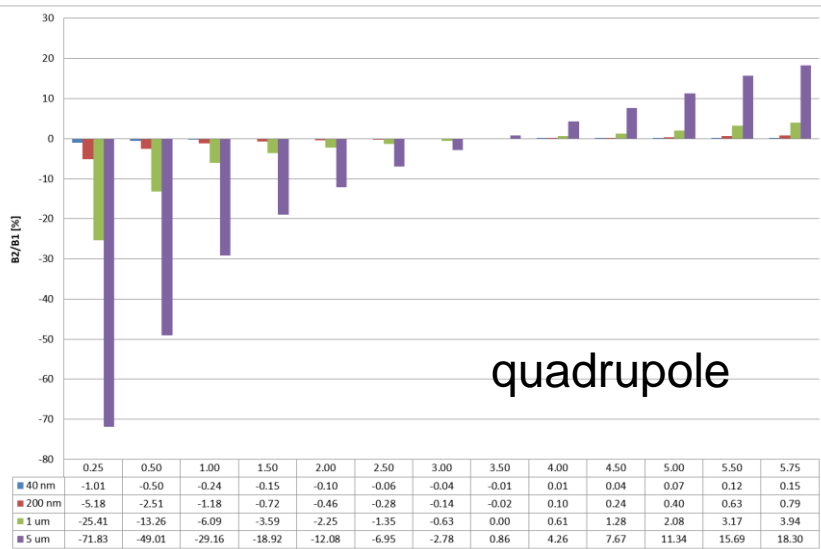
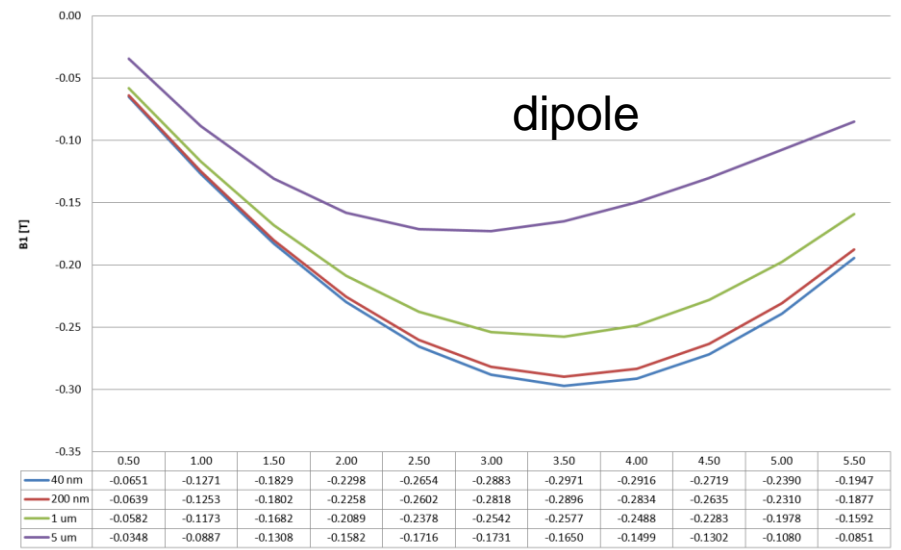

Coating impedance

Simplified kicker geometry

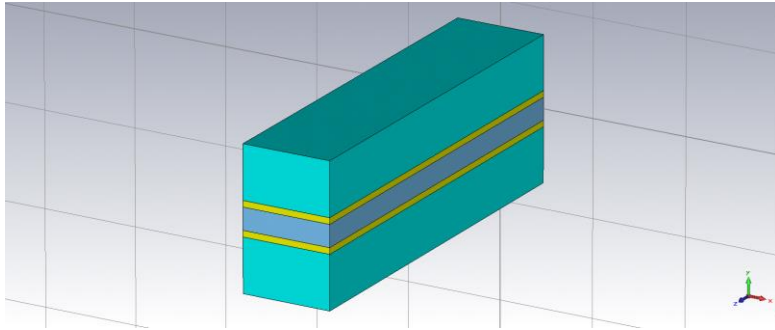

ImpedanceWake2D and CST simulations for Diamodn/ALBA vessel layout

- 5mm bunch length
- 6.5 mm ceramic thickness
- Ceramic as lossy metal coated (Ti 400 nm)

Courtesy E. Koukovini-Platia

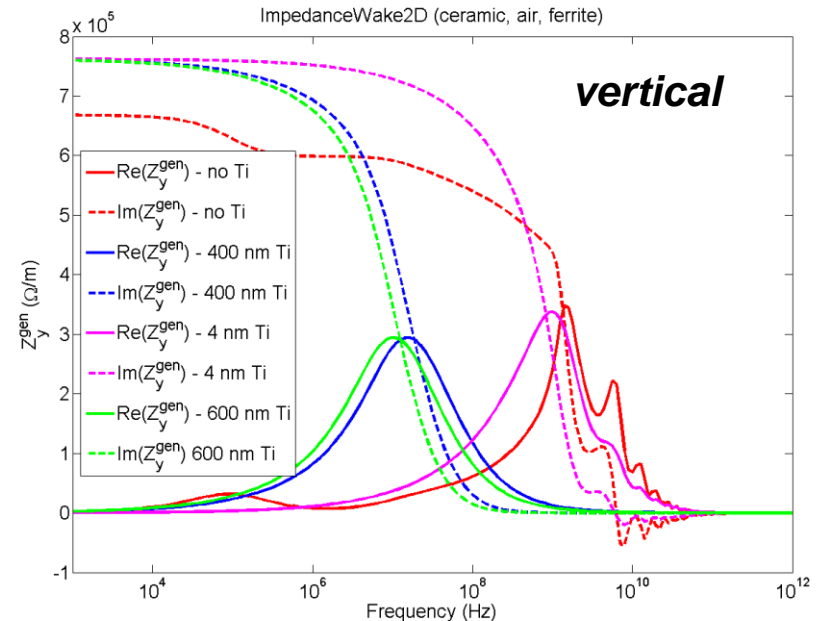
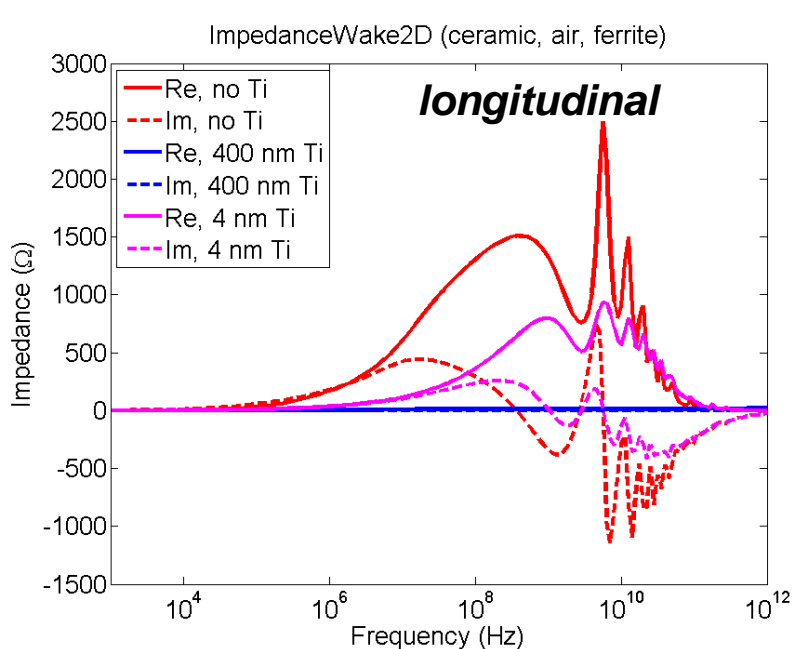

400 nm Ti- coating reduces significantly both L and Y impedance and shifts it to lower frequency

Coating thickness

Need coating to reduce RW impedance but it must be thick to be effective.
Need coating to take out static charge – but it must be thin (to avoid disturbing the main magnetic field pulse)

Comments for diamond parameters:

Ti-thickness beyond 1 μm generates too much magnetic shielding
Ti-thickness below ~ 200 nm it is not effective to reduce RW
(and would be very weak mechanically)

The geometry of current distribution is very different

Can this info be used to design an optimal coating ?

(Already suggested by S. Kurennoy: coating by stripes in PAC1993)

Ongoing R&D

Continue the investigation of the
magnetic modelling
beam dynamics data

Build compensation kickers a la Spring-8
Feedforward first
Feedback maybe later
adding TMBF studies
(correction through the whole pulse train)

Project for the construction of a NLK

SR injection kickers test stand

Magnet test stand funded at Diamond for
pulsed power supply tests
pulsed test of vacuum vessels
magnet measurements of pulsed magnets

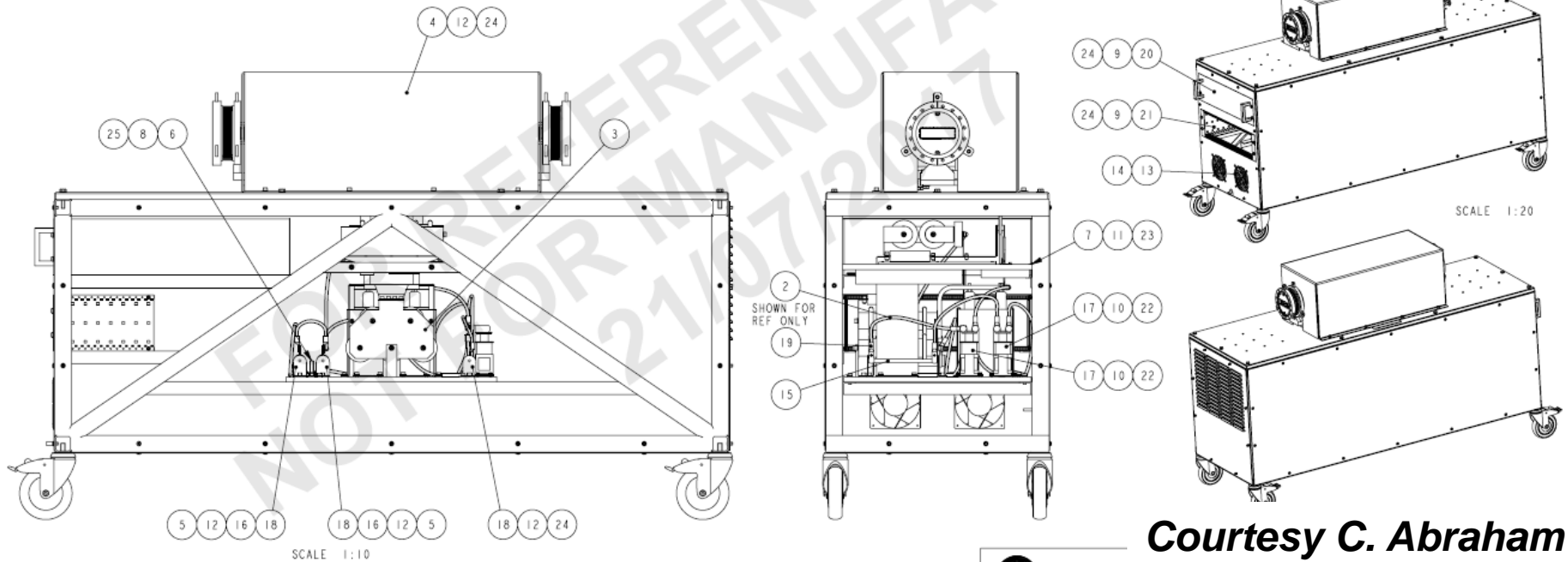

Courtesy C. Abraham

Non Linear Kicker at DLS

AP studies completed: NLK in straight 2 (also straight 14) would guarantee same injection efficiency as 4 kicker bump and existing booster.

Based on BESSY-II design

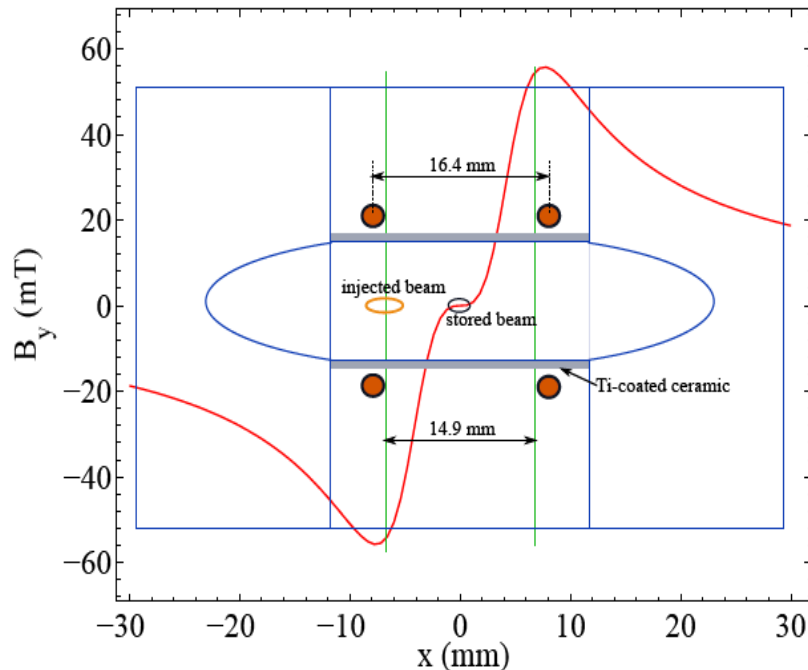

Table 1: Non-Linear Pulsed Kicker's Parameters

Description	Parameter
Peak field	55 mT
Deflection angle	2.2 mrad
Magnetic length	400 mm
Aperture (h/v)	72mm / 8.2mm
Pulse length	3.73 μ s, half-sinusoidal
Required current	710 A

Diamond II

Diamond II constraints

reduce the emittance (2.7 nm) at least a by a factor 10,

(...20, ...as much as possible)

maintain the straight sections (and the beamlines layout) as they are

Diamond II candidates

DDBA – 270 pm (off axis injection)

DTBA – 130 pm (off axis injection)

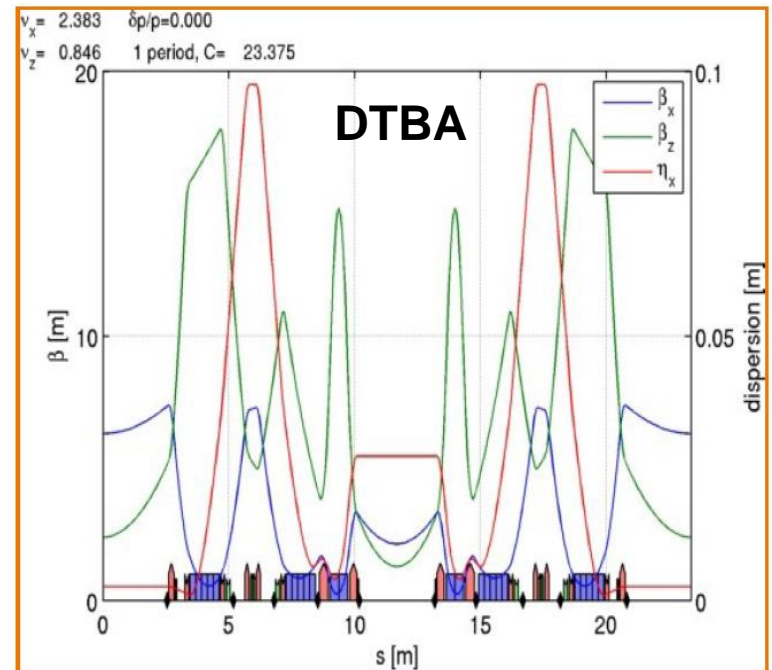
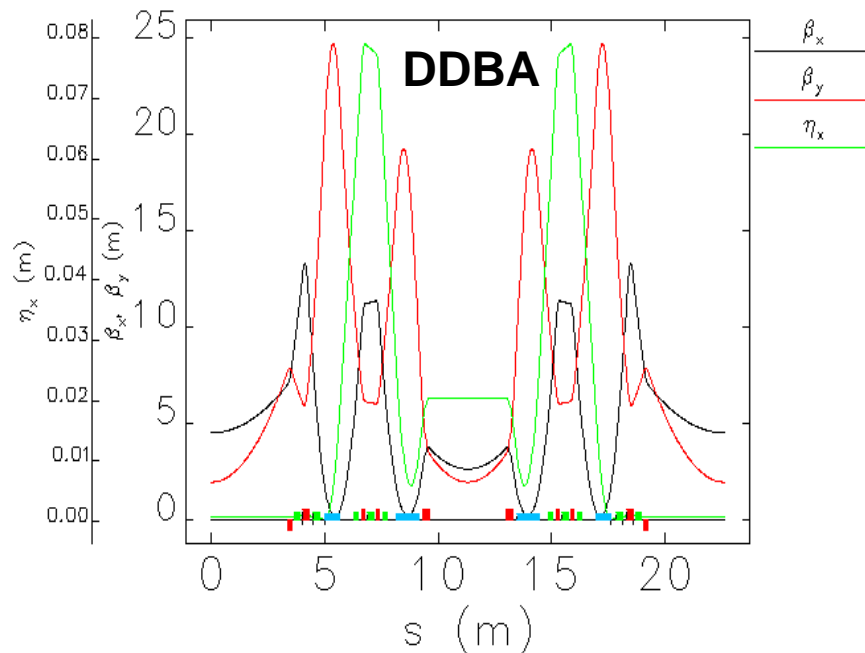

Diamond II

To reduce further the emittance and to re-gain some of the straight section length we are exploring new lattices giving up off-axis injection

New lattice with accumulator to reduce the new ring emittance to 75 pm?

Trading DA/MA for lower emittance and adequate length of straight

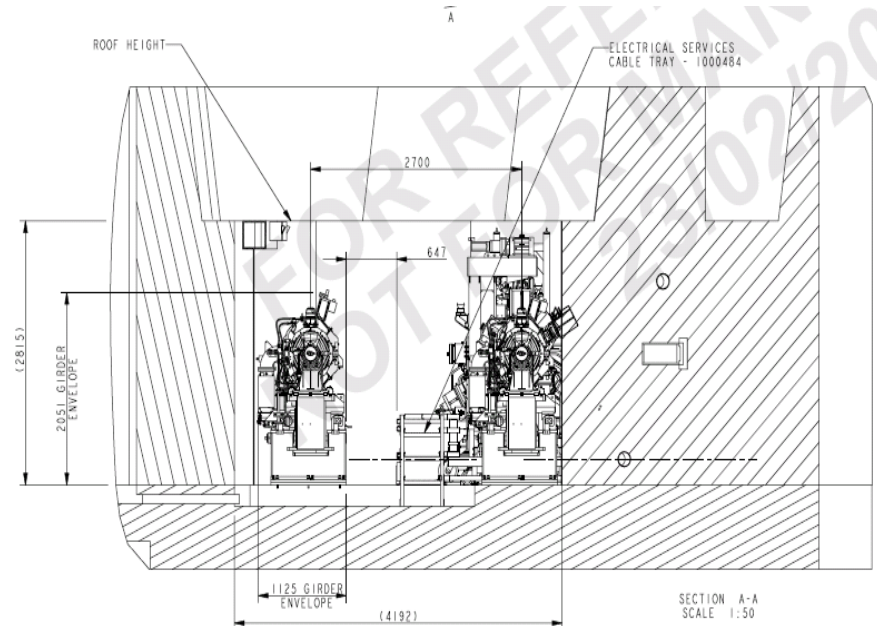
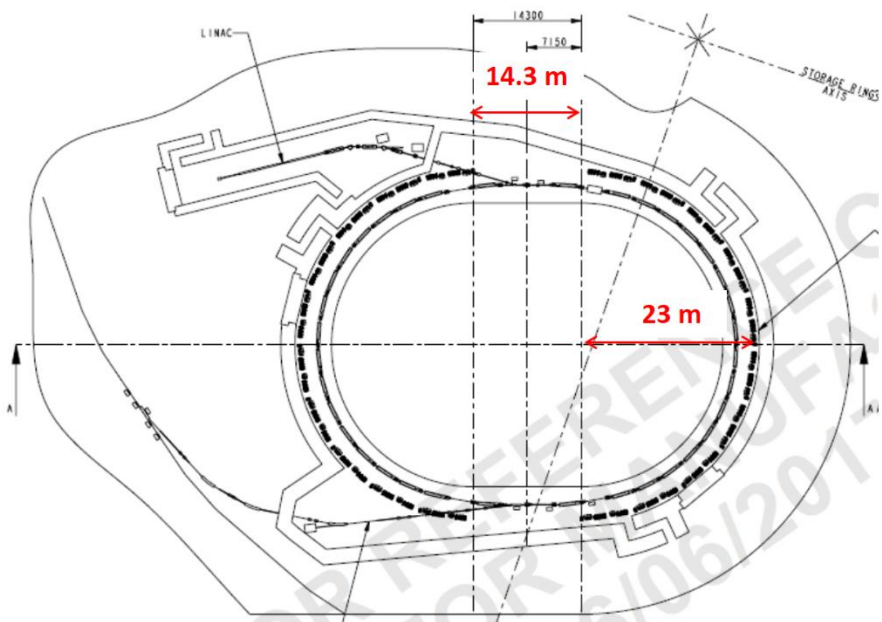

Use the booster tunnel (larger radius booster) or second ring in the tunnel

Diamond II – fill pattern with accumulator

Diamond I harmonic number is $h = 936$ (factors 2, 2, 2, 3, 3, 13)

Diamond II is likely to have $h = 935$ (factors 5, 11, 17)

A standard filling pattern could be:

8 trains of 105 bunches, 7 gaps of 12 bunches and 1 gap of 11 bunches

=> 22 ns rise / fall time for kicker, 110 ns flat top

=> 840 bunches filled, 0.3571 mA / bunch for 300 mA (now 0.333 mA/bunch)

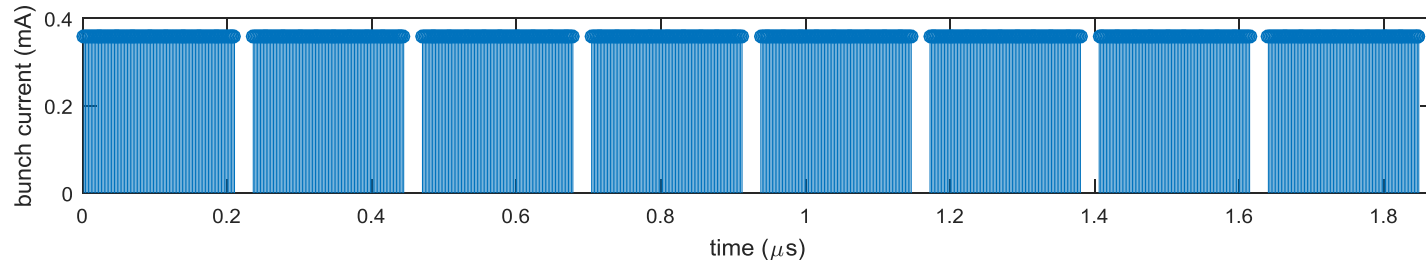

A hybrid filling pattern might be:

6 trains of 105 bunches separated by 10 bunches, then a gap of 127 bunches, then the hybrid bunch, then another gap of 127 bunches

=> 20 ns rise / fall time for kicker, 110 ns flat top

=> 630+1 bunches filled, 0.4762 mA/bunch for 300 mA (now 0.437 mA/bunch)

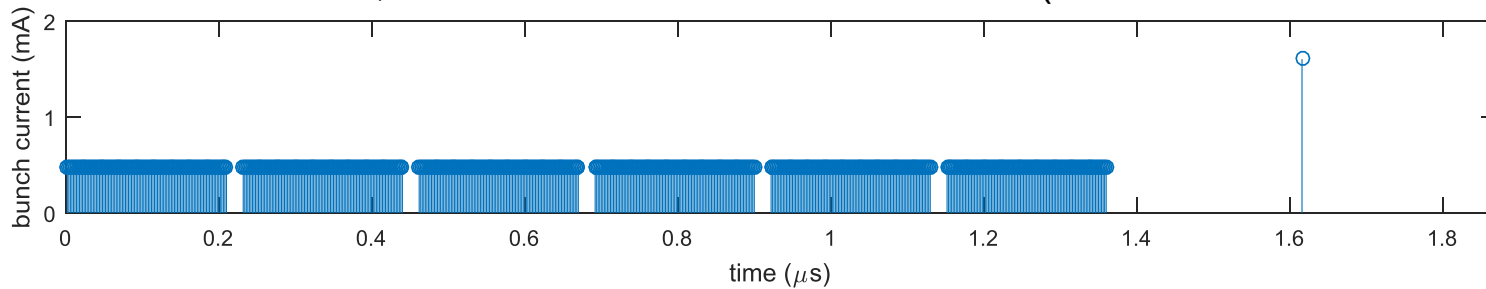

Fast pulsers



Company Products Applications Contact

Products - FPG series - FPG-N Nanosecond Pulsers

FID GmbH has developed a series of pulse generators with nanosecond rise time. FPG-N series pulse generators are designed for convenient laboratory or industrial use. These pulsers can be manufactured both in desktop or rack mount housings. FPG-N series includes all common features of FPG series.



Pulse generators of FPG-N series have a rise time ranging from 1 nanosecond to hundreds of nanoseconds.

For customers demanding rise times of less than 1 ns FID GmbH offers pulse generators of FPG-P series and FPG-SP series.

The following table of reference models of pulse generators will help you to estimate FID GmbH possibilities.

Series	Output voltage	Rise time	Pulse width	Max Pulse repetition frequency	Size (mm)	Lead time (months)
FPG 1-N	1 kV	1-2 ns	1 - 2 ns	1 MHz	300x200x120	3
FPG 5-N	5 kV	1-2 ns	1 - 2 ns	300 kHz	300x200x120	3
FPG 10-N	10 kV	1-2 ns	1 - 2 ns	100 kHz	300x200x120	3
FPG 20-N	20 kV	1-2 ns	1 - 10 ns	10 kHz	300x200x120	4
FPG 50-N	50 kV	1-2 ns	1 - 10 ns	2 kHz	400x400x160	4
FPG 100-N	100 kV	1-2 ns	1 - 3 ns	1 kHz	400x400x160	4
FPG 200-N	200 kV	1-2 ns	1 - 3 ns	1 kHz	400x400x160	5
FPG 500-N	500 kV	1-2 ns	1 - 100 ns	1 kHz	1000x400x300	5
FPG 1000-N	1 MV	1-2 ns	1 - 100 ns	1 kHz	1500x400x300	6

All specifications are given at 50 - 100 Ohm

Total efficiency can be 70-90% at the pulse width from 10 to 100 ns

Pulse duration is given at 50% of amplitude, other pulse widths are possible

Dimensions and lead time are approximate

Please also visit our Applications section, which describes pulse generators developed for specific fields of use.

Many types of benchtop pulsers can be implemented as pulsed power modules.

© 2007 FID GmbH

Products

Nanosecond and Picosecond Benchtop Pulse Generators

Overview
Nanosecond pulsers
Picosecond pulsers
Ultra-short pulse generators
High PRF pulsers
Multichannel pulsers

Nanosecond and Picosecond Pulse Power Modules

Overview
Nanosecond power modules
Picosecond power modules
Synchronization systems

DC Power Supplies

AC-DC power supplies
DC-DC power supplies

Accessories

Triggering pulsers
High voltage cables and connectors
Dummy loads
UWB antennas
Electrical field sensors
High voltage attenuators

Kentech Instruments Ltd.

contact us here

Navigate

- News
- About the company
- Staff
- Contacts
- Overseas Representatives
- New Products
- Pictures
- Products
- Tutorials
- Interesting Ideas
- FLIM
- Publications
- Documents
- Glossary
- Mission Statement
- Terms & Conditions
- Links
- Staff Vacancies
- Finding Us
- Webmaster

Products

PULSE GENERATOR SYSTEMS (up to 45kV with ~ 100ps rise time)	Pulser Links
X-RAY STREAK CAMERAS	XRSC
GATED OPTICAL IMAGERS	GOI-HRI links
GOI (< 100ps time resolution) single frame and four frame	Optical gate profiles
HRI High Rate Imager (~250ps frames at up to 100MHz)	GOI-HRI links
GATED X-RAY IMAGERS	Gated X-ray Imagers
DELAY GENERATORS	Delay Generators
POCKELS CELL DRIVERS	Pockels Cell links
ARBITRARY WAVEFORM GENERATORS	AWG links
ELECTRONICS FOR LASERS	Electronics for Lasers
MISCELLANEOUS PRODUCTS	PICTURES

Conclusions

Transparent injection is one of the key deliverable of the 10-years diamond vision

Achieving a perfect closure of the injection bump has proven to be basically impossible: issues with coating held to be responsible for much of the difficulties.

Better understanding needed from
magnet/thermal and beam dynamics modelling
pulse test facility under construction

Countermeasures based on
Compensation kickers and eventually nonlinear kicker

Diamond II: there is a strong push to reduce the emittance (and maintain long straight sections) that points towards the use of on-axis injection, hence fast pulsed magnets. Prototype and tests stands needed.

DLS is open for collaborations – AIRES/RULE can support them.

Acknowledgments

C. Abraham, M. Apollonio, M. Cox, N. Hammond, V. Kempson,
E. Koukovini-Platia, T. Pulampong (now at SLRI), I. Martin,
G. Rehm, A. Shahveh, B. Singh, and R.P. Walker

Thank you for your attention !