

Low Level RF challenges / Timing systems

A. Gallo

INFN

Lab. Nazionali Frascati



CAS course on
**Beam Dynamics
and Technologies
for Future Colliders**

**21 February to
6 March, 2018**

**Crowne Plaza Hotel,
Zurich, Switzerland**



PAUL SCHERRER INSTITUT

PSI

CERN Accelerator School
CH - 1211 Geneva 23
cas.web.cern.ch
Accelerator.school@cern.ch



- **MOTIVATIONS**

- ✓ Why accelerators need synchronization, and at what precision level

- **DEFINITIONS AND BASICS**

- ✓ Synchronization, Master Oscillator, Drift vs. Jitter
- ✓ Fourier and Laplace Transforms, Random processes, Phase noise in Oscillators
- ✓ Phase detectors, Phase Locked Loops

- **SYNCRONIZATION ARCHITECTURE AND PERFORMANCES**

- ✓ Phase lock of synchronization clients (RF systems, Lasers, Diagnostics, ...)
- ✓ Residual absolute and relative phase jitter
- ✓ Reference distribution – actively stabilized links

- **BEAM ARRIVAL TIME FLUCTUATIONS**

- ✓ Bunch arrival time measurement techniques
- ✓ Bunch arrival time downstream magnetic compressors
- ✓ Beam synchronization – general case

CONCLUSIONS AND REFERENCES

Every accelerator is built to produce some ***specific physical process***.

One ***necessary condition*** for an efficient and stable machine operation is that ***some events have to happen at the same time*** (simultaneously for an observer in the laboratory frame) or in a ***rigidly defined temporal sequence***, within a maximum allowed time error.

If the ***simultaneity*** or the time separation ***of the events fluctuates*** beyond the specifications, ***the performances of the machine are spoiled***, and the quantity and quality of the accelerator products are compromised.

Clearly, the tolerances on the time fluctuations are different for different kind of accelerators. The ***smaller the tolerances***, the ***tighter the level of synchronization required***. In the last decade a new generation of accelerator projects such as FEL radiation sources or plasma wave based boosters ***has pushed the level of the synchronization specifications down to the fs scale***.

A. Gallo, Low Level RF challenges/timing systems

Beam Dynamics and Technologies for Future Colliders Feb.21 – March 6 2018, Zurich, CH

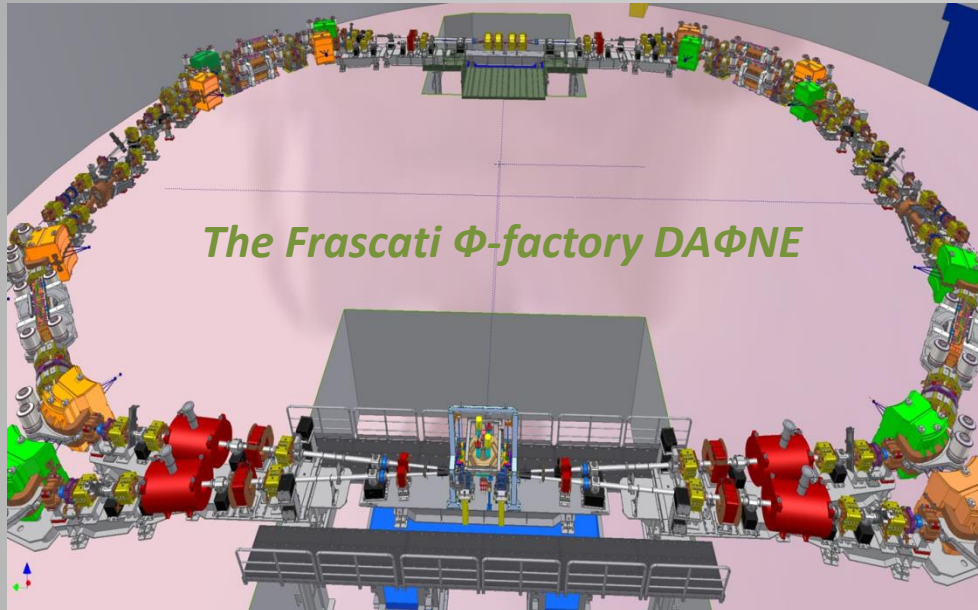

Bunches of the 2 colliding beams need to **arrive** at the **Interaction Point** (max vertical focalization) at the same time.

Waist length $\approx \beta_y \approx \sigma_z$
(hourglass effect)

Synchronization requirement:

$$\Delta t \ll \sigma_{t_{bunch}} = \frac{1}{c} \cdot \sigma_{z_{bunch}}$$

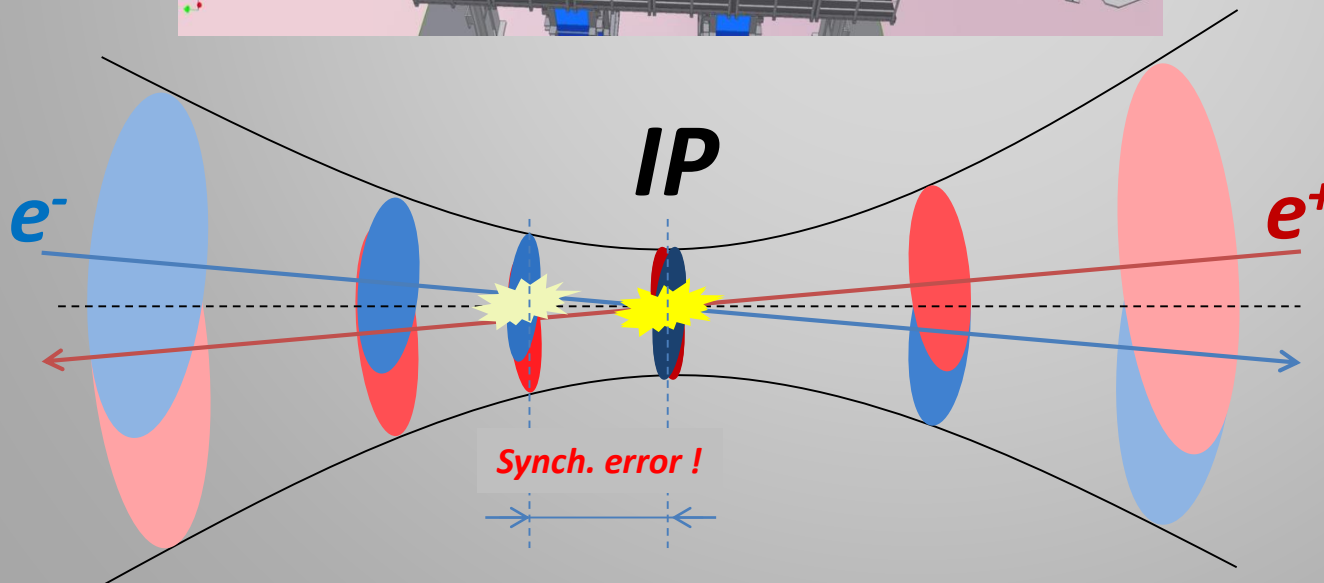

CIRCULAR COLLIDERS:

$$\sigma_z \approx 1 \text{ cm} \rightarrow \Delta t < 10 \text{ ps}$$

LINEAR COLLIDER (ILC):

$$\sigma_z < 1 \text{ mm} \rightarrow \Delta t < 1 \text{ ps}$$

RF Stability spec

A. Gallo, *Low Level RF challenges/timing systems*
 Beam Dynamics and Technologies for Future Colliders Feb.21 – March 6 2018, Zurich, CH

SPARC Test Facility INFN Frascati Labs

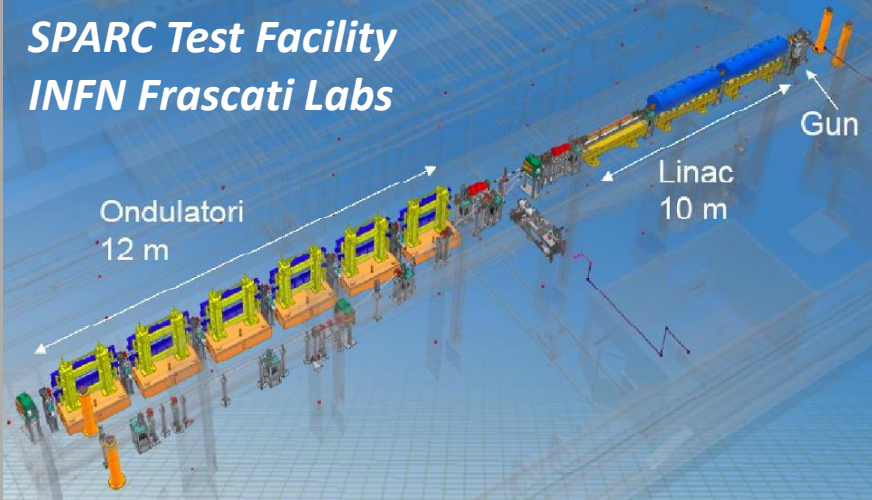

Free Electro Laser machines had a crucial role in pushing the accelerator synchronization requirements and techniques to a new frontier in the last ≈ 15 years.

The simplest FEL regime, the **SASE (Self-Amplified Spontaneous Emission)**, requires high-brightness bunches, being:

$$B \div \frac{I_{bunch}}{\epsilon_{\perp}^2}$$

Large peak currents I_{bunch} are typically obtained by **short laser pulses** illuminating a **photo-cathode** embedded in an RF Gun accelerating structure, and furtherly increased with **bunch compression** techniques.

Small transverse emittances ϵ_{\perp} can be obtained with **tight control** of the global machine WP, including amplitude and phase of the RF fields, magnetic focusing, laser arrival time, ...

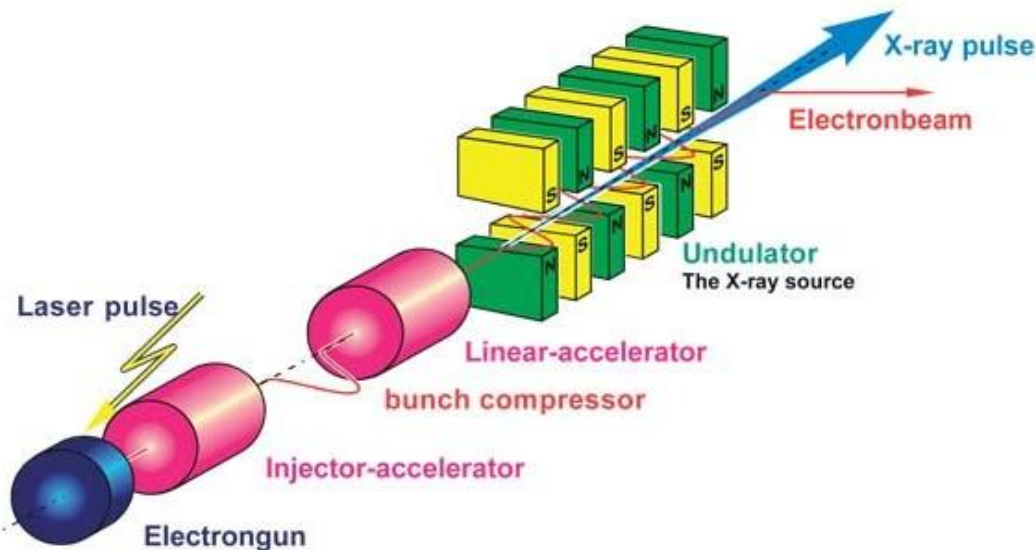

Global Synchronization requirements: < 500 fs rms

Pump-probe technique is widely requested and applied by user experimentalists.

Physical / chemical processes are **initialized** by ultra-short **laser pulses**, then the system status is **probed** by **FEL radiation**.

The dynamics of the process under study is captured and stored in a “snapshots” record.

Pump laser and FEL pulses need to be **synchronized** at level of the **time-resolution** required by the experiments (down to ≈ 10 fs).

The relative delay between pump and probe pulses needs to be finely and precisely scanned with proper time-resolution.

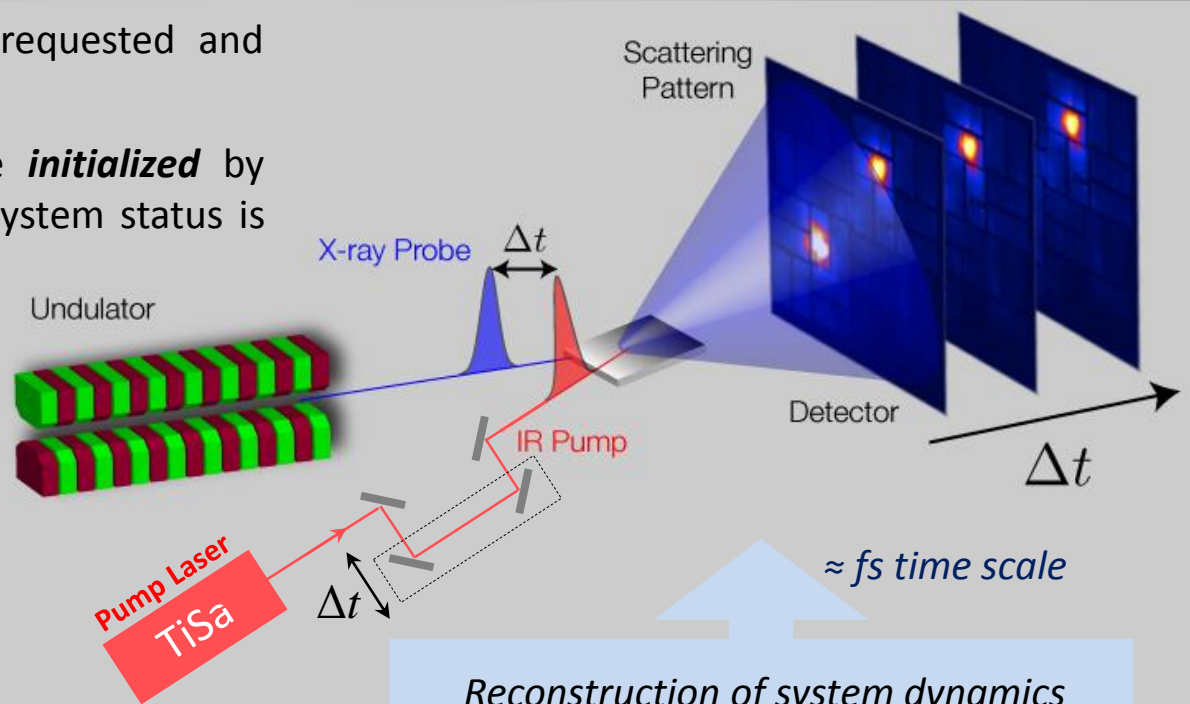

**Synchronization requirements
(FEL vs Pump Laser pulses):
 ≈ 10 fs rms**



Plasma acceleration is the new frontier in accelerator physics, to overcome the gradient limits of the RF technology in the way to compact, high energy machines.

Wakefield Laser-Plasma Acceleration (WLPA) is a technique using an extremely intense laser pulse on a gas jet to generate a plasma wave with large accelerating gradients (many GV/m).

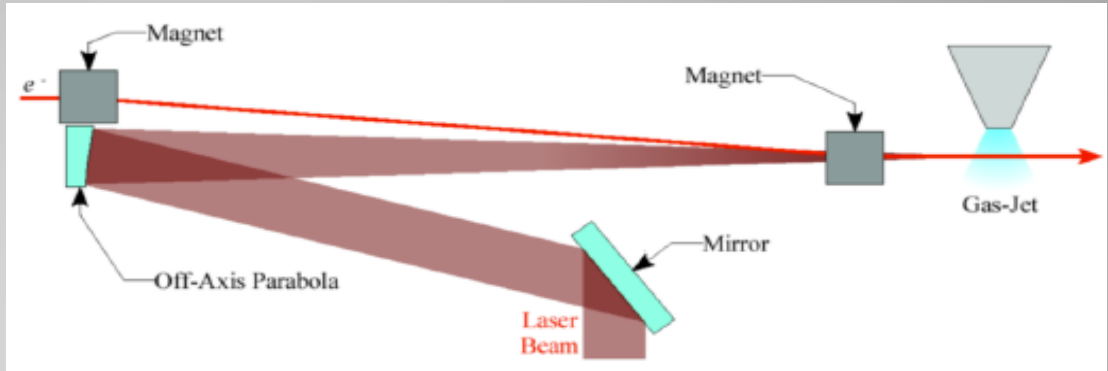

To produce good quality beams external bunches have to be injected in the plasma wave. The “accelerating buckets” in the plasma wave are typically few 100 μm long.

The injected bunches have to be very short to limit the energy spread after acceleration, and ideally need to be injected constantly in the same position of the plasma wave to avoid shot-to-shot energy fluctuations.

This requires synchronization at the level of a small fraction of the plasma wave period.

**Synchronization requirements
(external bunch vs laser pulse):
< 10 fs rms**

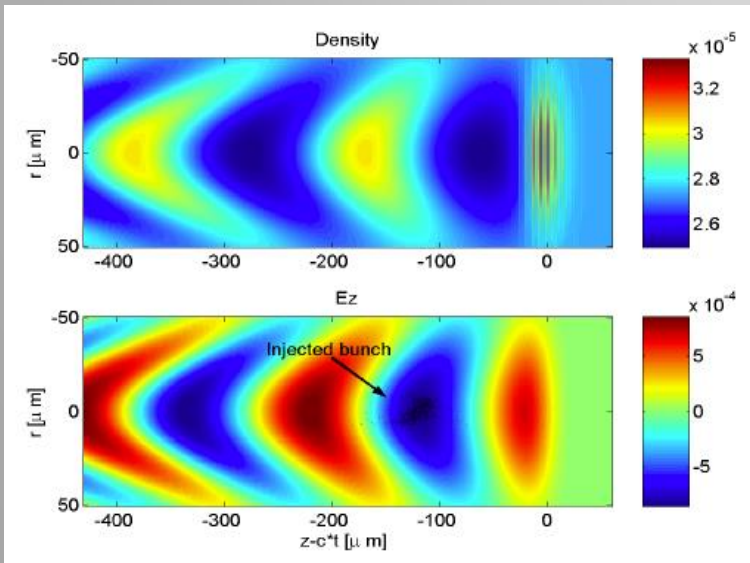

GLOSSARY

Every accelerator is built to produce some **specific physical processes** (shots of bullet particles, nuclear and sub-nuclear reactions, synchrotron radiation, FEL radiation, Compton photons, ...).

It turns out that a **necessary condition** for an efficient and reproducible event production is the **relative temporal alignment** of **all the accelerator sub-systems** impacting the beam longitudinal phase-space and time-of-arrival (such as RF fields, PC laser system, ...), and of the **beam bunches** with **any other system they have to interact with** during and after the acceleration (such as RF fields, seeding lasers, pump lasers, interaction lasers, ...).

The **synchronization system** is the complex including all the **hardware**, the **feedback processes** and the **control algorithms** required to keep **time-aligned** the **beam bunches** and **all the machine critical sub-systems** within the facility specifications.

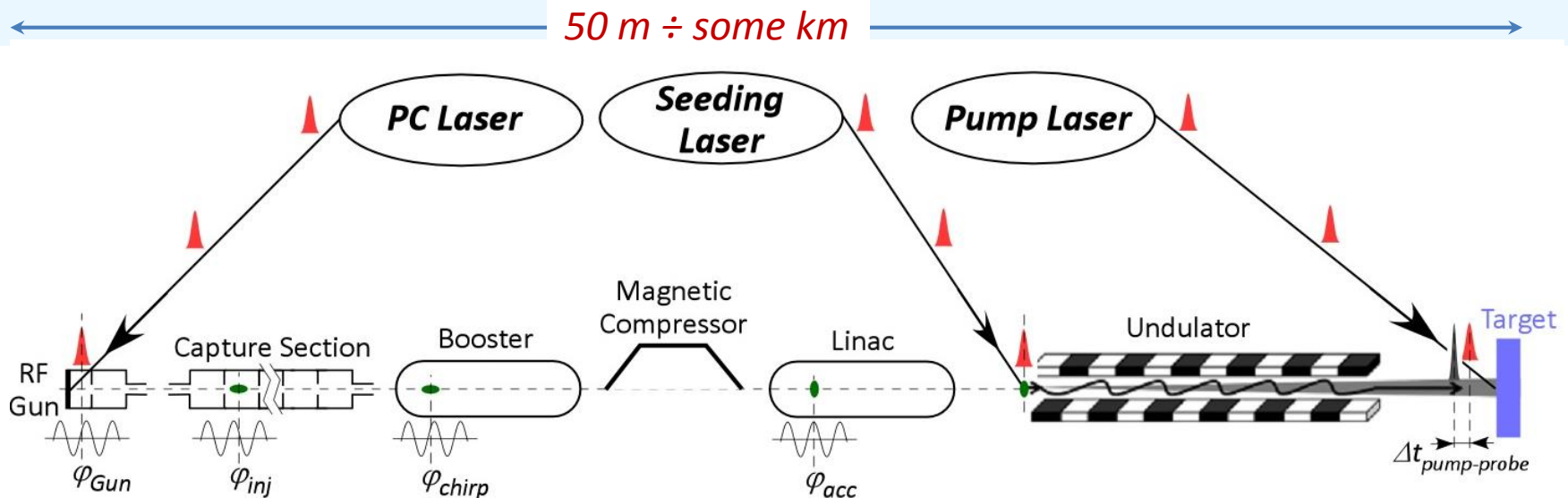

Naive approach: can each sub-system be synchronized to a local high-stability clock to have a good global synchronization of the whole facility ?

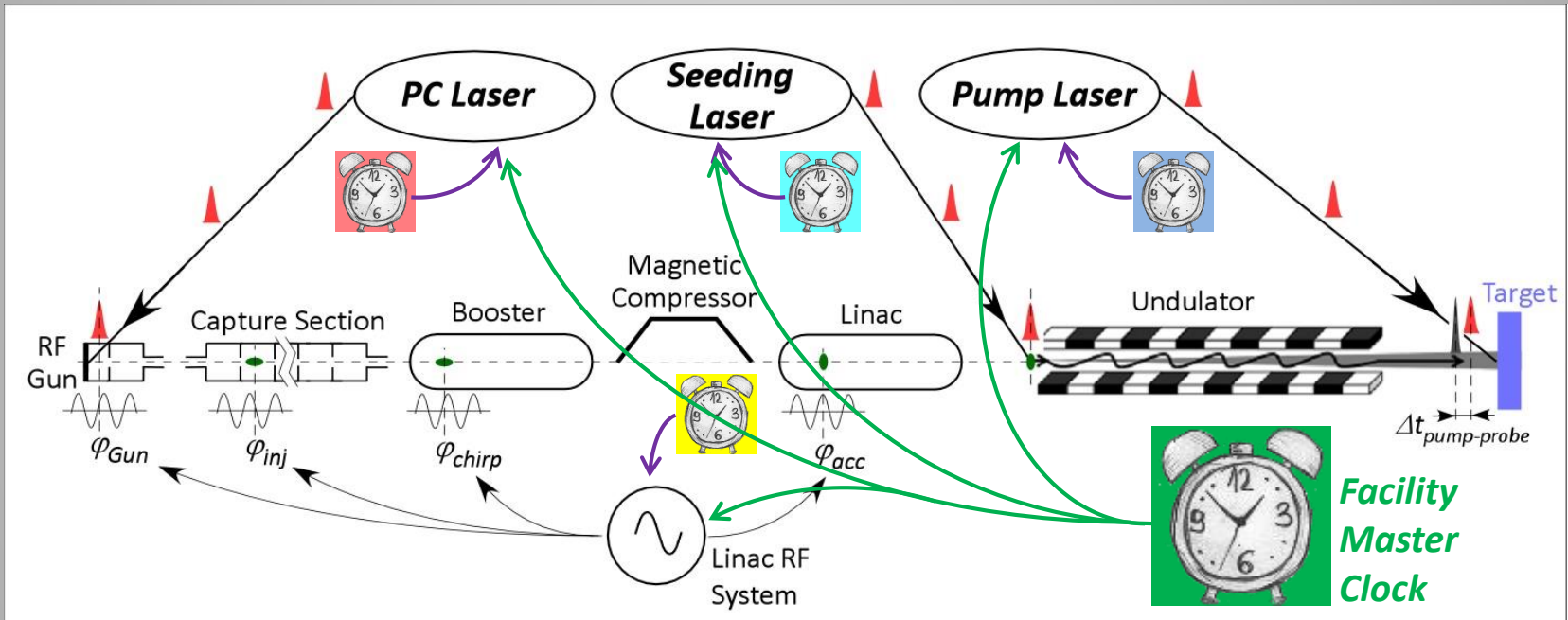

Best optical clocks $\rightarrow \Delta\omega/\omega \approx 10^{-18} \rightarrow \Delta T/T \approx 10^{-18} \rightarrow T \approx 10 \text{ fs}/10^{-18} \approx \underline{\underline{3 \text{ hours !!!}}}$

It is impossible to preserve a tight phase relation over long time scales even with the state-of-the-art technology.

All sub-systems need to be **continuously re-synchronized** by a **common master clock** that has to be distributed to the all "clients" spread over the facility with a star network architecture.

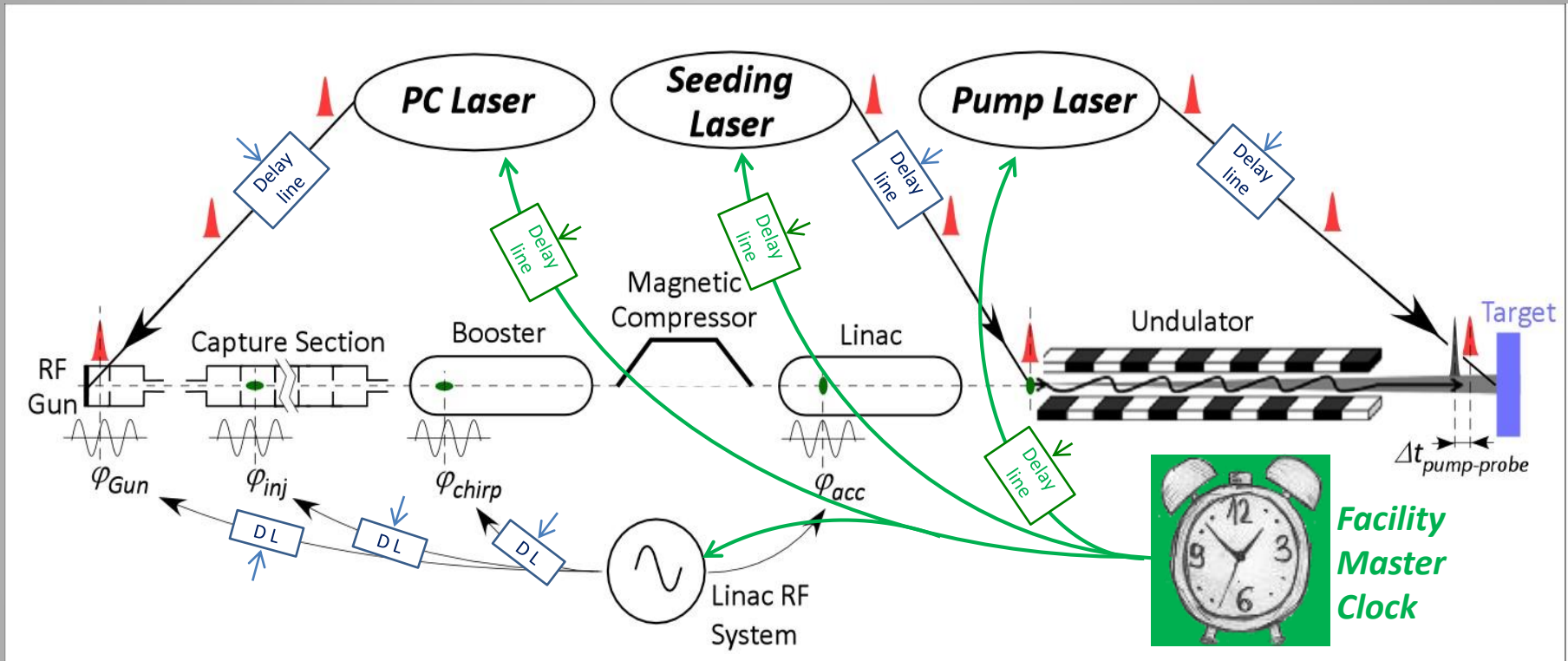

Once the local oscillators have been locked to the reference, they can be shifted in time by means of delay lines of various types – translation stages with mirrors for lasers, trombone-lines or electrical phase shifters for RF signals. This allows setting, correcting, optimizing and changing the working point of the facility synchronization.

Delay lines can be placed either downstream the oscillators or on the reference signal on its path to the client oscillator. The function accomplished is exactly the same.

For simplicity, in most of the following sketches the presence of the delay line will be omitted

The **Master Oscillator** of a facility based on particle accelerators is typically a **good(*)**, **low phase noise** μ -wave generator acting as timing reference for the machine sub-systems. It is often indicated as the **RMO (RF Master Oscillator)**.

The timing reference signal can be distributed straightforwardly as a pure sine-wave voltage through coaxial cables, or firstly **encoded in the repetition rate of a pulsed (mode-locked) laser** (or sometimes in the amplitude modulation of a CW laser), and then distributed through optical-fiber links.

Optical fibers provide **less signal attenuation** and **larger bandwidths**, so optical technology is definitely preferred for synchronization reference distribution, at least for large facilities.

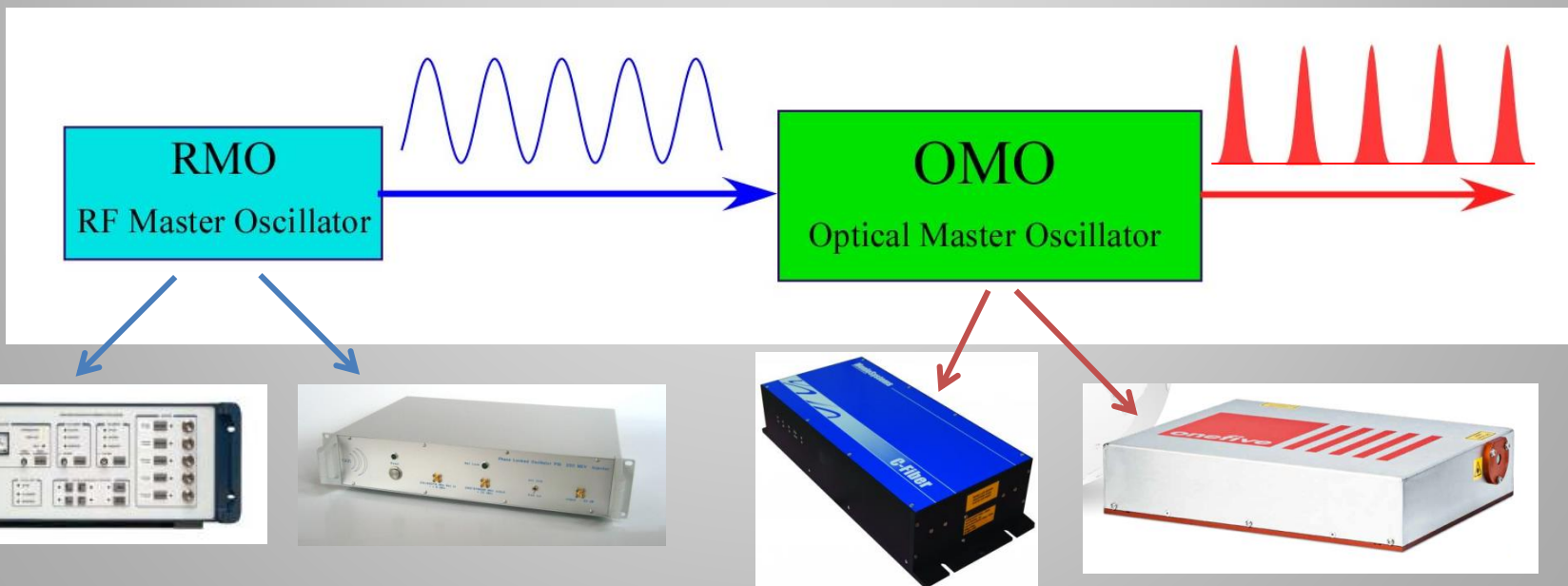

(*) the role of the phase purity of the reference will be discussed later

Optical: mode-locked lasers

A **mode-locked laser** consists in an **optical cavity** hosting an active (amplifying) medium capable of sustaining **a large number of longitudinal modes** with frequencies $\nu_k = k\nu_0 = kc/L$ within the bandwidth of the active medium, being L the cavity round trip length and k integer. If the modes are forced to **oscillate in phase** and the medium emission BW is wide enough, a **very short pulse** (≈ 100 fs) travels forth and back in the cavity and a sample is coupled out through a leaking mirror.

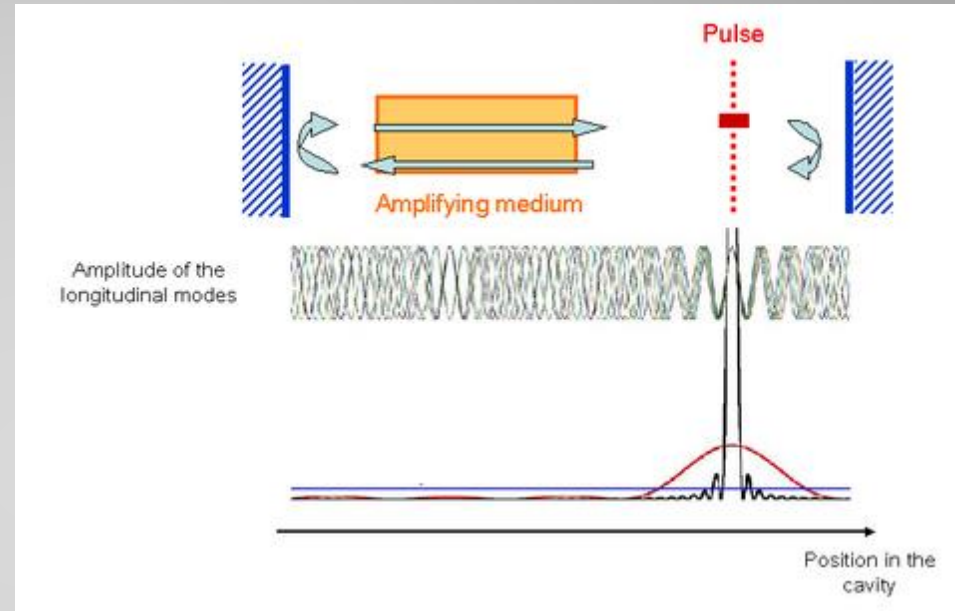

Origami



Laser specifications	Origami-05	Origami-08	Origami-10	Origami-15
Center wavelength	513 - 535 nm	765 - 785 nm	1025 - 1070 nm	1530 - 1586 nm
Pulse Duration ^{1,2}	<100 - 230 fs	<60 - 200 fs	<70 - 400 fs	<80 - 500 fs
Avg. output power (up to) ²	100 mW	30 mW	250 mW	120 mW
Pulse energy (up to) ²	1.2 nJ	0.7 nJ	5 nJ	2 nJ
Peak power (up to) ²	10 kW	4.5 kW	30 kW	15 kW
Pulse repetition rate ²	20 MHz - 1.3 GHz			
Spectral bandwidth	transform-limited ($\tau_p \cdot \Delta\nu \approx 0.32$) $\rightarrow 1/\pi$			
Beam quality	$M^2 < 1.1$, TEM ₀₀			
PER	> 23 dB			
Amplitude noise (24 h)	< 0.2% rms, < 0.5% pk-pk			
Center wavelength drift	< 0.1 nm pk-pk			
Laser output	collimated free space (fiber output optional)			

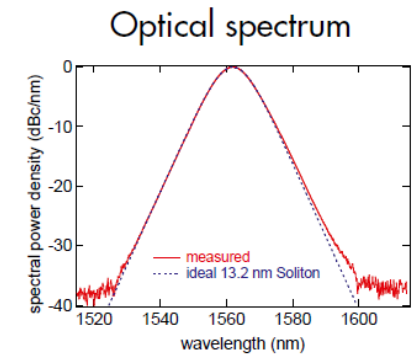
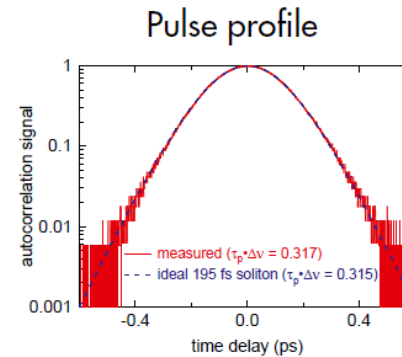

<http://www.onefive.com/ds/Datasheet%20Origami%20LP.pdf>

Tasks of a Synchronization system:

- ✓ Generate and transport the reference signal to any client local position with constant delay and minimal drifts;
- ✓ Lock the client (laser, RF, ...) fundamental frequency to the reference with minimal residual jitter;
- ✓ Monitor clients and beam, and apply delay corrections to compensate residual (out-of-loop) drifts.

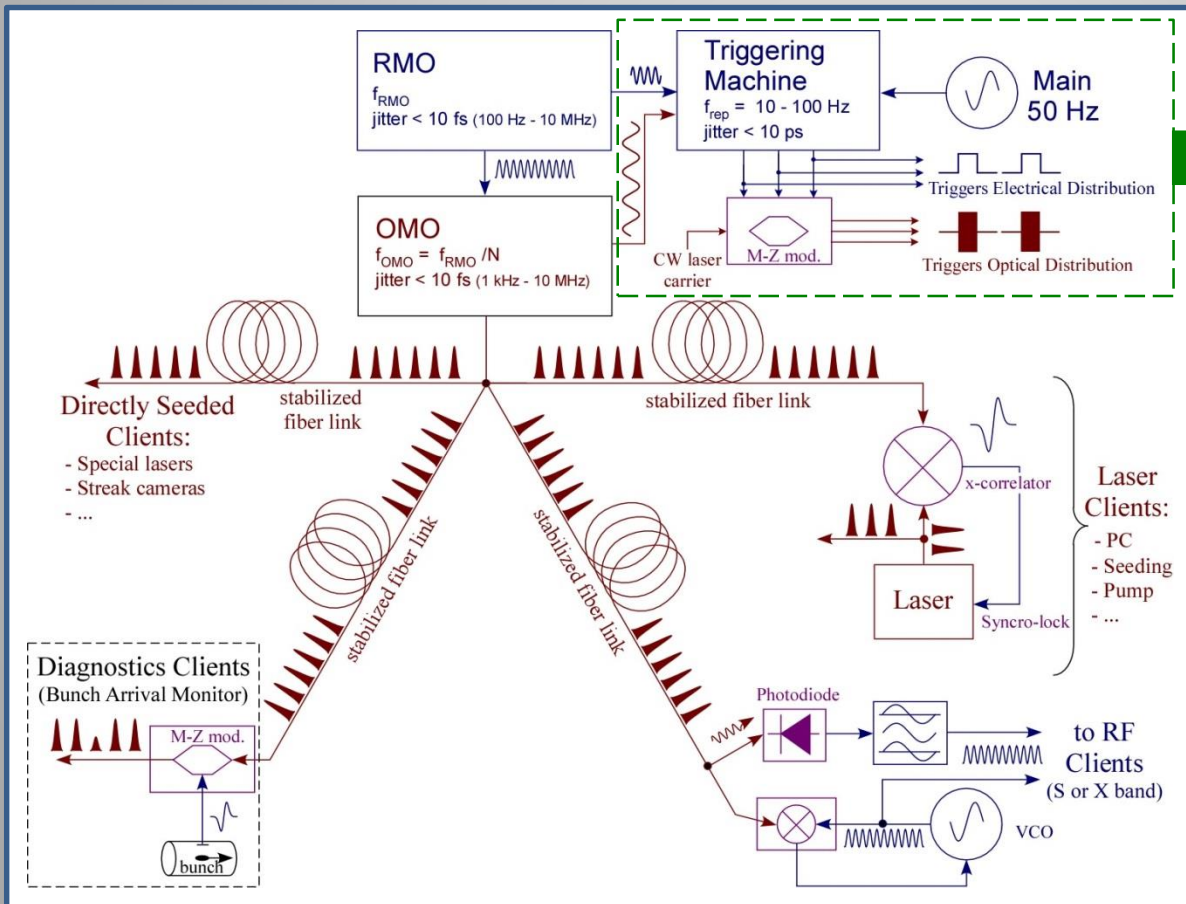

Triggers

Digital signals still in the Timing business but the required precision is orders of magnitude less demanding.

Not covered in this lecture (but nevertheless an important aspect of machine operation).

BASICS

- ***Fourier and Laplace Transforms***
- ***Random Processes***
- ***Phase Noise in Oscillators***

Random process summary

Let's consider a random variable $x(t)$ representing a physical observable quantity.

- Stationary process: statistical properties invariant for a t' time shift $x(t) \rightarrow x(t + t')$

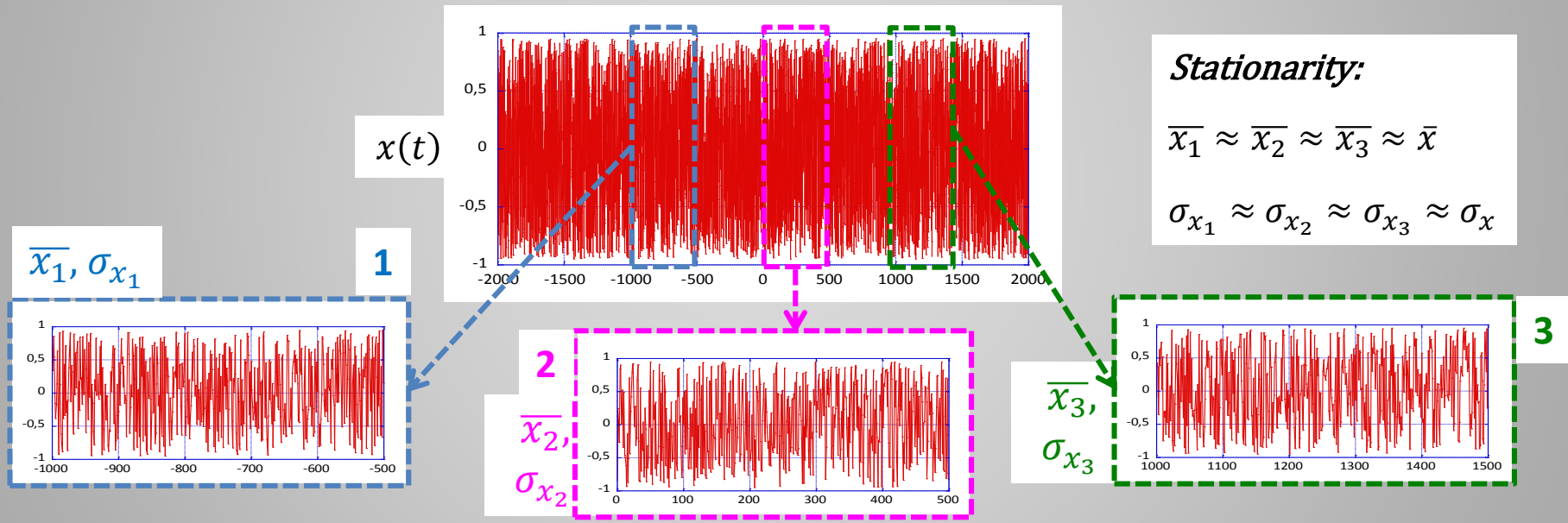

- Ergodic process: statistical properties can be estimated by a single process realization
- Uncorrelation: if $x(t)$ and $y(t)$ are 2 random variables completely uncorrelated (statistically independent), then:

$$\sigma_{x+y}^2 = \sigma_x^2 + \sigma_y^2 \quad \text{with} \quad \sigma_x^2 \stackrel{\text{def}}{=} \overline{x^2} - \bar{x}^2$$

Power spectrum:

Since $x_{rms} \neq 0$, a real random variable $x(t)$ is in general not directly Fourier transformable. However, if we observe $x(t)$ only for a **finite time** ΔT we may truncate the function outside the interval $[-\Delta T/2$

$$x_{\Delta T}(t) = \begin{cases} x(t) & -\Delta T/2 \leq t \leq \Delta T/2 \\ 0 & \text{elsewhere} \end{cases}$$

Let $X_{\Delta T}(f)$ be the **Fourier transform** of the truncated function $x_{\Delta T}(t)$. Then the rms value of the random variable can be computed on the base of the Fourier transform $X_{\Delta T}(f)$ according to:

$$x_{rms}^2 = \int_0^{+\infty} S_x(f) df \quad \text{with} \quad S_x(f) \stackrel{\text{def}}{=} \lim_{\Delta T \rightarrow \infty} 2 \cdot \frac{|X_{\Delta T}(f)|^2}{\Delta T}$$

The function $S_x(f)$ is called “**power spectrum**” or “**power spectral density**” of the random variable $x(t)$. The time duration of the variable observation ΔT sets the minimum frequency $f_{min} \approx 1/\Delta T$ containing meaningful information in the spectrum of $x_{\Delta T}(t)$.

Fourier and Laplace transforms are used to compute the response of **Linear Time Invariant (LTI)** systems:

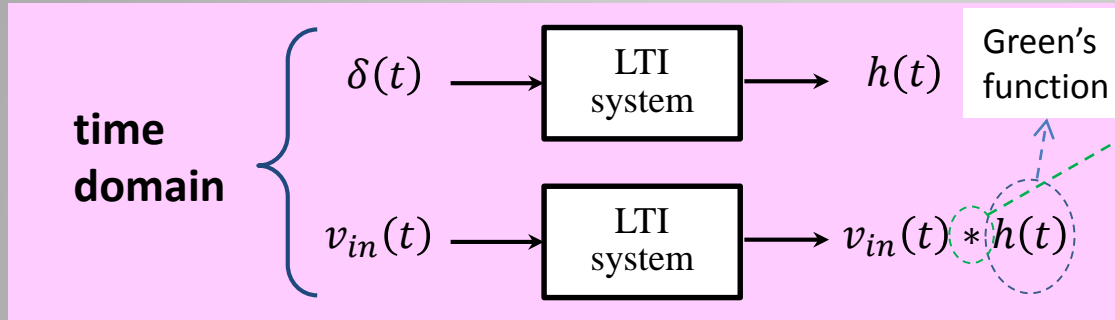

convolution product

$$(x * y)(t) \stackrel{\text{def}}{=} \int_{-\infty}^{+\infty} x(t + \tau) \cdot y(\tau) d\tau$$

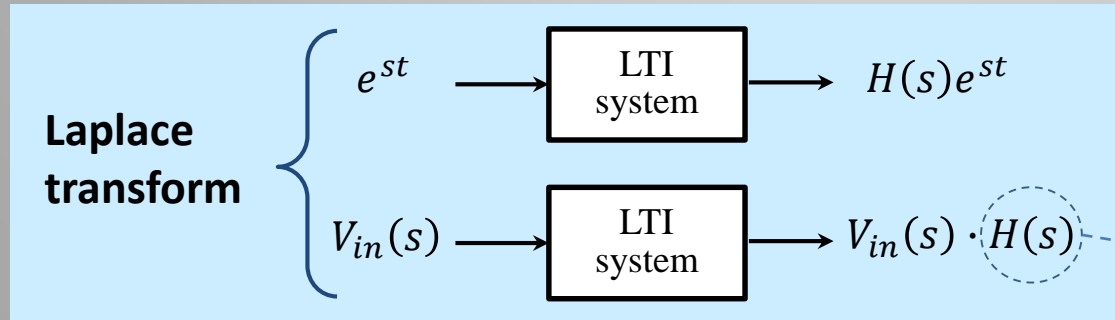
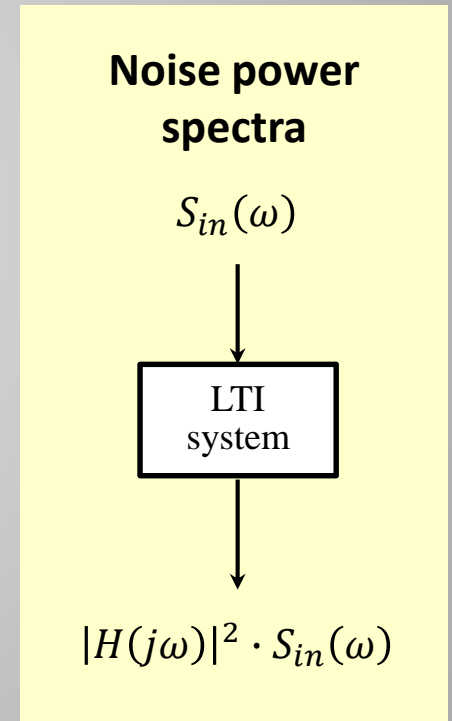
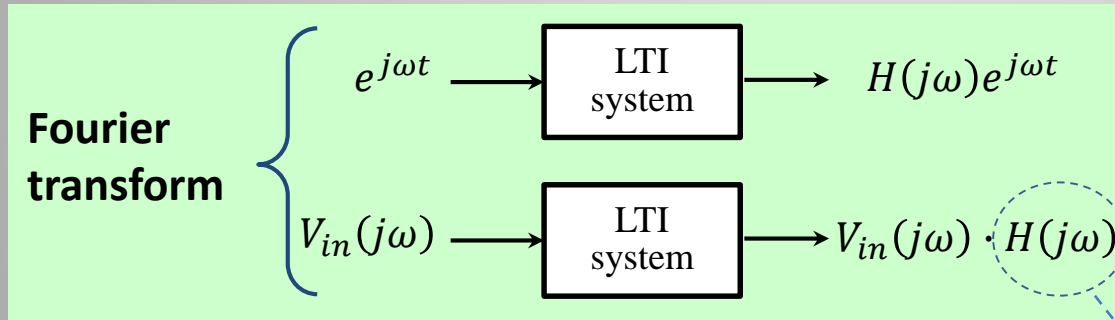

LTI system Transfer functions

The most important task of a Synchronization system is to **lock firmly the phase** of each **client** to the **reference oscillator** in order to minimize the residual jitter. The clients are basically **VCOs** (*Voltage Controlled Oscillators*), i.e. **local oscillators** (electrical for RF systems, optical for laser systems) whose fundamental frequency can be changed by applying a voltage to a control port.

Before discussing the lock schematics and performances, it is worth introducing some **basic concepts** on **phase noise** in **real oscillators**.

Ideal oscillator

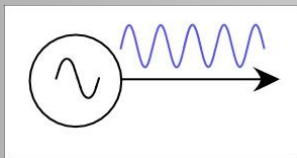

$$V(t) = V_0 \cdot \cos(\omega_0 t + \varphi_0)$$

Ideal Spectrum

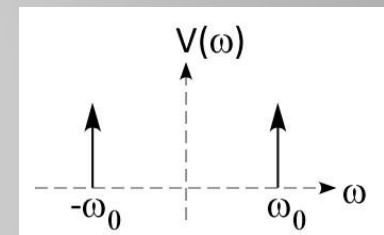
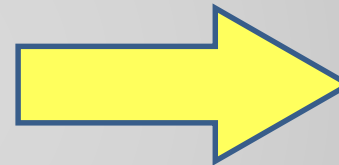

Real oscillator

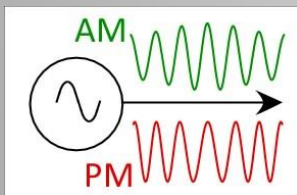

$$V(t) = V_0 \cdot [1 + \alpha(t)] \cdot \cos[\omega_0 t + \varphi(t)]$$

Real Spectrum

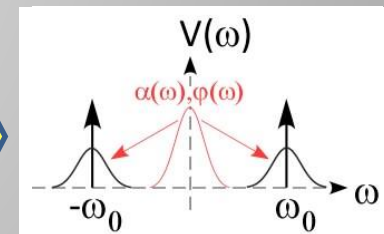
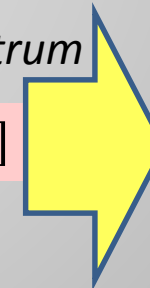

In real oscillators the amplitude and phase will always fluctuate in time by a certain amount because of the unavoidable presence of noise. However, by common sense, a well behaving real oscillator has to satisfy the following conditions:

$$|\alpha(t)| \ll 1; \quad \left| \frac{d\varphi}{dt} \right| \ll \omega_0$$

Again, for practical reasons, we are only interested in observations of the random variable $\varphi(t)$ for a finite time ΔT . So we may truncate the function outside the interval $[-\Delta T/2, \Delta T/2]$ to recover the function transformability.

$$\varphi_{\Delta T}(t) = \begin{cases} \varphi(t) & -\Delta T/2 \leq t \leq \Delta T/2 \\ 0 & \text{elsewhere} \end{cases}$$

Let $\Phi_{\Delta T}(f)$ be the Fourier transform of the truncated function $\varphi_{\Delta T}(t)$. We have:

$$(\varphi_{rms}^2)_{\Delta T} = \int_{f_{min}}^{+\infty} S_{\varphi}(f) df \quad \text{with} \quad S_{\varphi}(f) \stackrel{\text{def}}{=} 2 \frac{|\Phi_{\Delta T}(f)|^2}{\Delta T}$$

$S_{\varphi}(f)$ is the **phase noise power spectral density**, whose dimensions are rad^2/Hz . Very often the single-sideband logarithmic scale $10 \cdot \text{Log}|S_{\varphi}(f)/2|$ is used, whose units are dBc/Hz .

Again, the time duration of the variable observation ΔT sets the minimum frequency $f_{min} \approx 1/\Delta T$ containing meaningful information on the spectrum $\Phi_{\Delta T}(f)$ of the phase noise $\varphi_{\Delta T}(t)$.

IMPORTANT:

we might still write

$$\varphi_{rms}^2 = \lim_{\Delta T \rightarrow \infty} (\varphi_{rms}^2)_{\Delta T} = \int_0^{+\infty} \left(2 \cdot \lim_{\Delta T \rightarrow \infty} \frac{|\Phi_{\Delta T}(f)|^2}{\Delta T} \right) df = \int_0^{+\infty} S_{\varphi}(f) df$$

but we must be aware that φ_{rms} in some case **might diverge**. This is physically possible since the **power** in the carrier does only **depend** on **amplitude** and **not** on **phase**. In these cases the rms value can only be specified for a given observation time ΔT or equivalently for a frequency range of integration $[f_1, f_2]$.

Phase Noise Nature and Spectra

A. Gallo, Low Level RF challenges/timing systems

Beam Dynamics and Technologies for Future Colliders Feb.21 – March 6 2018, Zurich, CH

Close-in phase noise:

$$S_{\varphi}(f) = \sum \frac{b_{-k}}{f^k} \quad k = 0,1,2,3, \dots$$

$$S_{FM}(f) \xrightarrow{\text{F or L transforms}} S_{PM}(f) = S_{FM}(f)/f^2$$

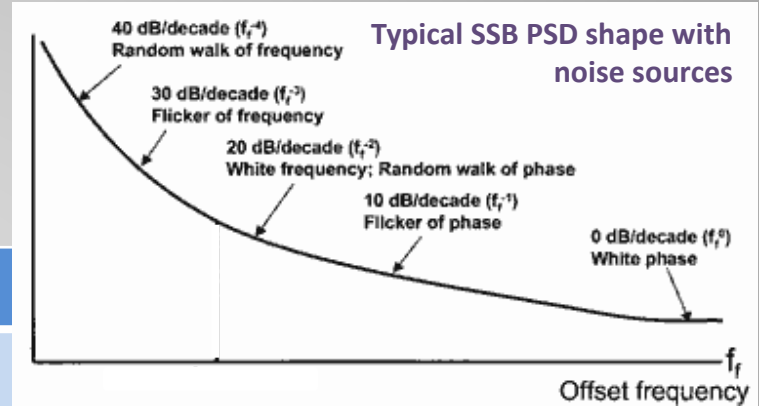

	Type	Origin	$S_{\varphi}(f)$
f^0	White	Thermal noise of resistors	$F \cdot kT/P_0$
	Shot	Current quantization	$2q\bar{i}R/P_0$
f^{-1}	Flicker	Flicking PM	b_{-1}/f
f^{-2}	White FM	Thermal FM noise	$b_0^{FM} \cdot \frac{1}{f^2}$
	Random walk	Brownian motion	b_{-2}/f^2
f^{-3}	Flicker FM	Flicking FM	$\frac{b_{-1}^{FM}}{f} \cdot \frac{1}{f^2}$
f^{-4}	Random walk FM	Brownian motion \rightarrow FM	$\frac{b_{-2}^{FM}}{f^2} \cdot \frac{1}{f^2}$
f^{-n}	...	high orders ...	

$$F \stackrel{\text{def}}{=} SNR_{in}/SNR_{out}$$

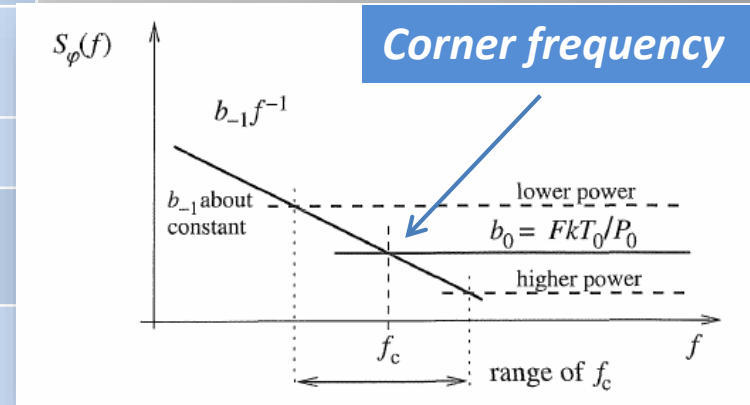

$$[b_{-k}] = \text{rad}^2 \text{Hz}^{(k-1)}$$

A. Gallo, Low Level RF challenges/timing systems
 Beam Dynamics and Technologies for Future Colliders Feb.21 – March 6 2018, Zurich, CH

Time jitter can be computed according to:

$$\sigma_t^2 = \frac{\sigma_\phi^2}{\omega_c^2} = \frac{1}{\omega_c^2} \int_{f_{min}}^{+\infty} S_\phi(f) df$$

same time jitter $\rightarrow S_\phi(f) \div \omega_c^2$

Phase noise spectral densities of different oscillators have to be compared at same carrier frequency ω_c or scaled as ω_c^{-2} before comparison.

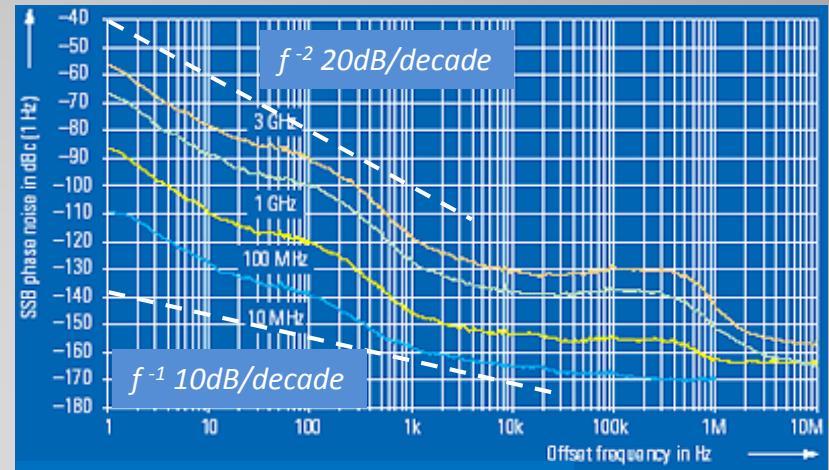

Commercial frequency synthesizer

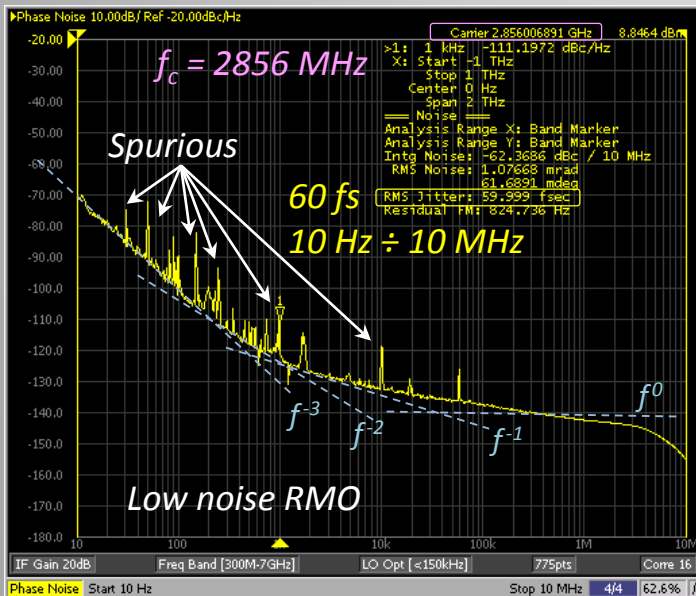

<http://www.onefive.com/ds/Datasheet%20Origami%20LP.pdf>

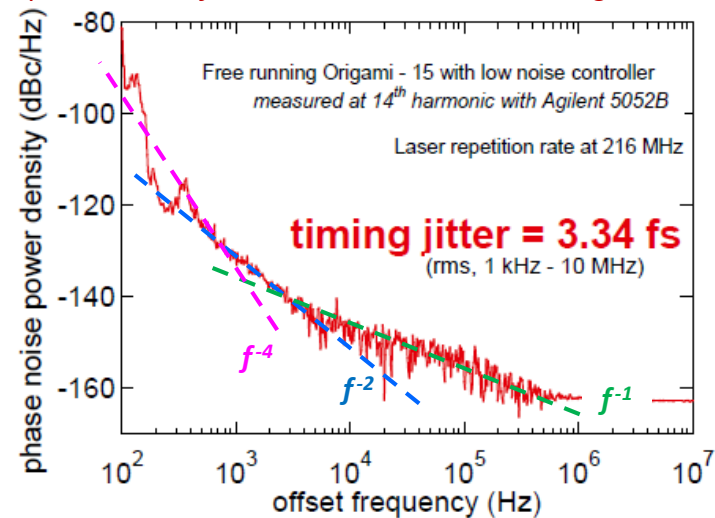

OMO – Mode-locked laser – $f = 3024$ MHz

BASICS

- ***Phase Detectors***
- ***Phase Locked Loops***

Phase detection on RF signals

The **Double Balanced Mixer** is the **most diffused RF device** for frequency translation (up/down conversion) and detection of the relative phase between 2 RF signals (LO and RF ports). The LO voltage is differentially applied on a diode bridge switching on/off alternatively the D_1 - D_2 and D_3 - D_4 pairs, so that the voltage at IF is:

$$V_{IF}(t) = V_{RF}(t) \cdot \text{sgn}[V_{LO}(t)]$$

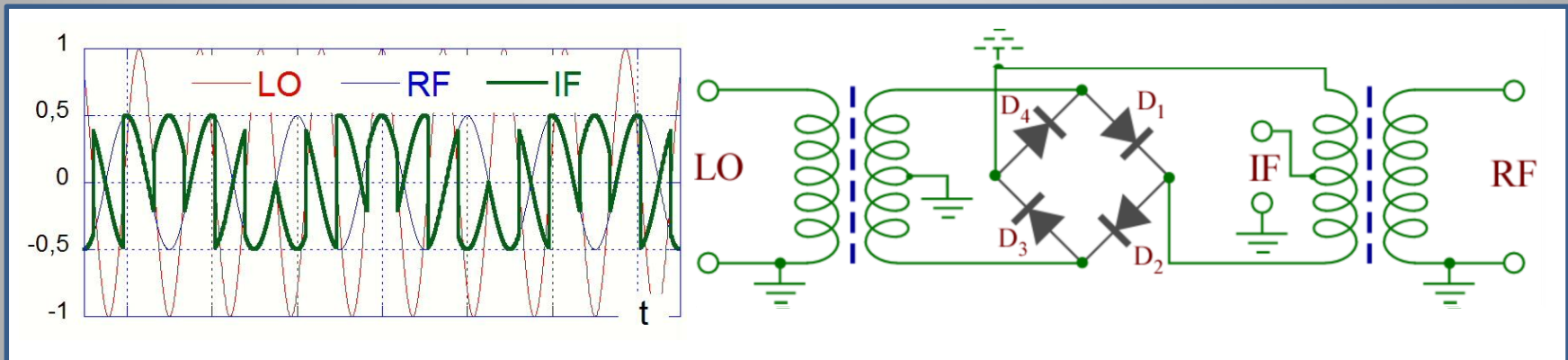

$$V_{RF}(t) = V_{RF} \cdot \cos(\omega_{RF}t); \quad V_{LO}(t) = V_{LO} \cdot \cos(\omega_{LO}t)$$

$$V_{RF} \ll V_{LO}$$

$$\begin{aligned} V_{IF}(t) &= V_{RF} \cos(\omega_{RF}t) \cdot \text{sgn}[\cos(\omega_{LO}t)] = V_{RF} \cos(\omega_{RF}t) \cdot \sum_{n=\text{odds}} \frac{4}{n\pi} \cos(n\omega_{LO}t) = \\ &= \frac{2}{\pi} V_{RF} [\cos((\omega_{LO} - \omega_{RF})t) + \cos((\omega_{LO} + \omega_{RF})t) + \text{intermod products}] \end{aligned}$$

Phase detection on RF signals

If $f_{LO} = f_{RF}$ the IF signal has a DC component given by: $V_{IF}|_{DC} = \langle V_{IF}(t) \rangle = k_{CL} A_{RF} \cos \varphi$

$$A_{RF} \cos(\omega t + \varphi)$$

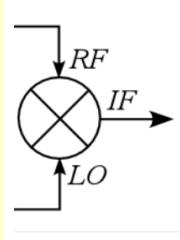

$$A_{LO} \cos(\omega t)$$

$$V_{det} = V_{IF} = V(\varphi) + \text{high harm.}$$

$$A_{RF} \ll A_{LO} \Rightarrow V_{det}(\varphi) = k_{CL} A_{RF} \cos \varphi$$

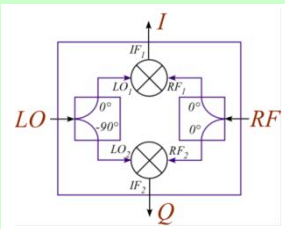
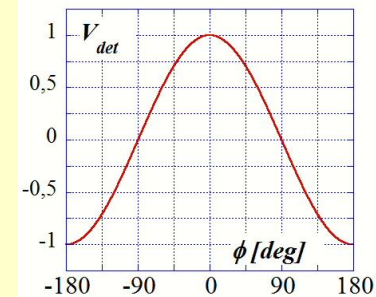

$$\begin{cases} V_I = k_{CL} A_{RF} \cos(\varphi) + \text{high harmonics} \\ V_Q = k_{CL} A_{RF} \sin(\varphi) + \text{high harmonics} \end{cases} \Rightarrow \begin{cases} A_{RF} \div \sqrt{V_I^2 + V_Q^2} \\ \varphi = \arctan(V_Q/V_I) + \frac{\pi}{2} [1 - \text{sgn}(V_I)] \end{cases}$$

$$\left. \frac{dV_{det}}{d\varphi} \right|_{\varphi=\pm\pi/2} = k_{CL} A_{RF} \underset{A_{RF}=1V}{\underset{CL=6dB}{\approx 5 \div 10 \text{ mV/Deg}}} \underset{f_c=10GHz}{\approx 15 \div 30 \text{ mV/ps}}$$

- ✓ Passive
- ✓ Cheap, Robust
- ✓ Wideband
- ✓ Sensitivity proportional to level, AM → PM not fully rejected
- ✓ Noise figure $F \approx CL$
- ✓ Good sensitivity but lower wrt optical devices

A. Gallo, *Low Level RF challenges/timing systems*
 Beam Dynamics and Technologies for Future Colliders Feb.21 – March 6 2018, Zurich, CH

Time domain

$T \approx 5 \div 15 \text{ ns} = 1/f_{rep}$

Frequency domain

Direct conversion with photo detector (PD)

- Low phase noise
- Temperature drifts (0.4ps/C°)
- AM to PM conversion (0.5-4ps/mW)

Phase detection between RF and Laser – Sagnac Loop Interferometer or BOM-PD

(Balanced Optical Microwave Phase Detector)

Recently (≈ 10 years) special devices to perform direct measurements of the relative phase between an RF voltage and a train of short laser pulses have been developed

balanced optical mixer to lock RF osc.

- insensitive against laser fluctuation
- Very low temperature drifts

Results: $f=1.3\text{GHz}$ jitter & drift $< 10 \text{ fs}$ rms *limited by detection!*

Balanced cross correlation of very short optical pulses ($\sigma_t \approx 200$ fs) provides an **extremely sensitive** measurement of the **relative delay between 2 pulses**.

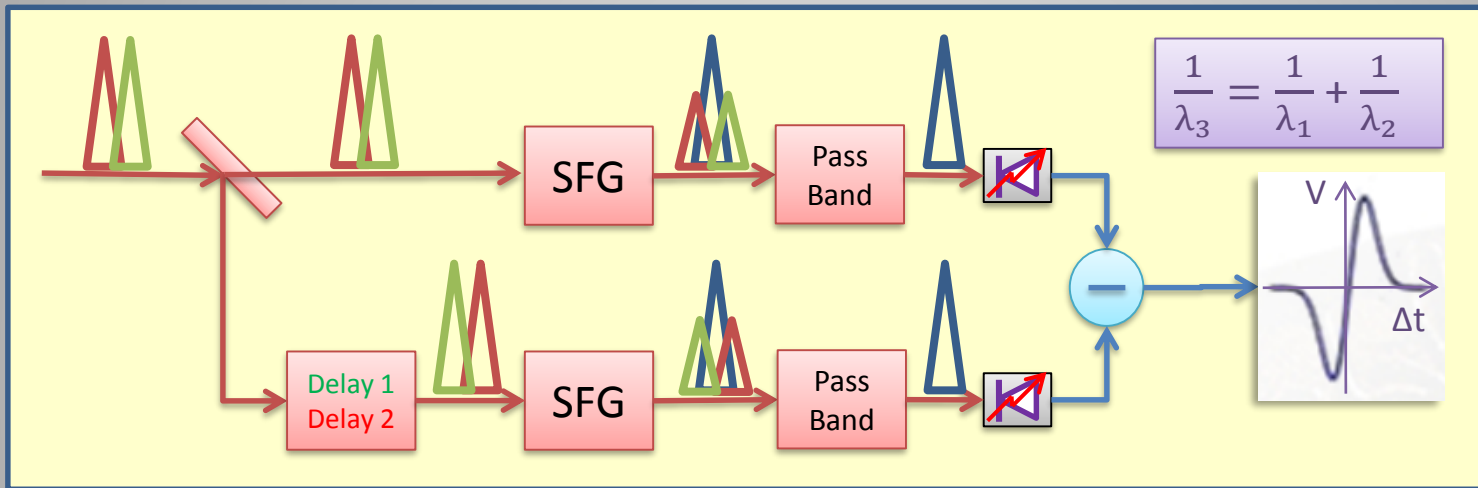

The two pulses have orthogonal polarization and generate a shorter wavelength pulse proportional to their time overlap in each branch by means of non-linear crystal.

In a second branch the two polarizations experience a differential delay $\Delta T = T_1 - T_2 \approx \sigma_t$. The amplitudes of the interaction radiation pulses are converted to voltages by photodiodes and their difference is taken as the detector output V_0 .

If the initial time delay between the pulses is exactly $\Delta T/2$ then clearly $V_0 \approx 0$ (balance), while it grows rapidly as soon as initial delay deviates.

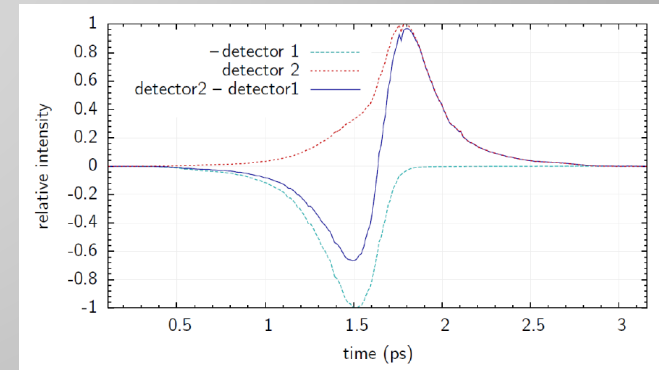

Detection sensitivity up to 10 mV/fs achievable with ultra-short pulses!!!

What is **peculiar** in **PLLs** for clients of a **stabilization system** of a Particle Accelerator facility ?

- ✓ Both the reference and client oscillators can be either RF VCOs or laser cavities. Phase detectors are chosen consequently;
- ✓ Laser oscillators behave as VCOs by trimming the cavity length through a piezo controlled mirror.
 - Limited modulation bandwidth (\approx few kHz typical);
 - Limited dynamic range ($\Delta f/f \approx 10^{-6}$), overcome by adding motorized translational stages to enlarge the mirror positioning range;
 - At frequencies beyond PLL bandwidth ($f > 1$ kHz) mode-locked lasers exhibit excellent low-phase noise spectrum.

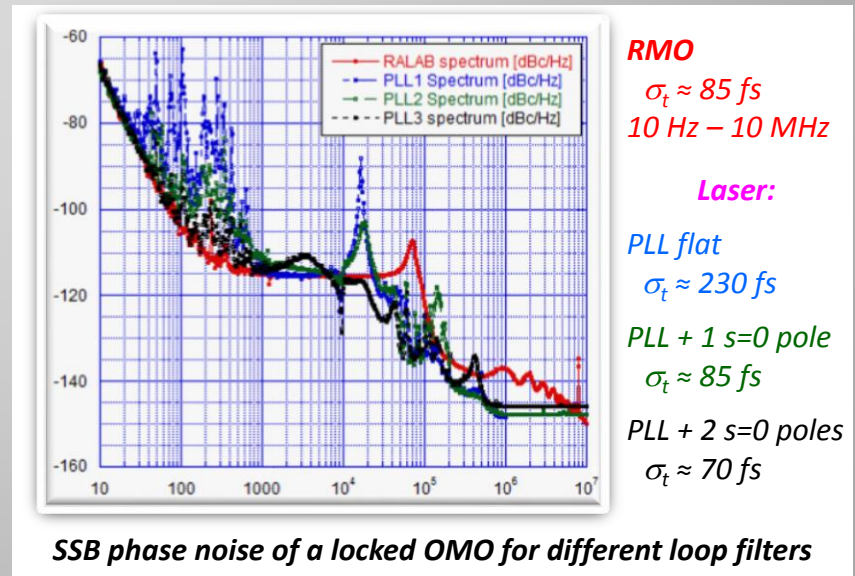
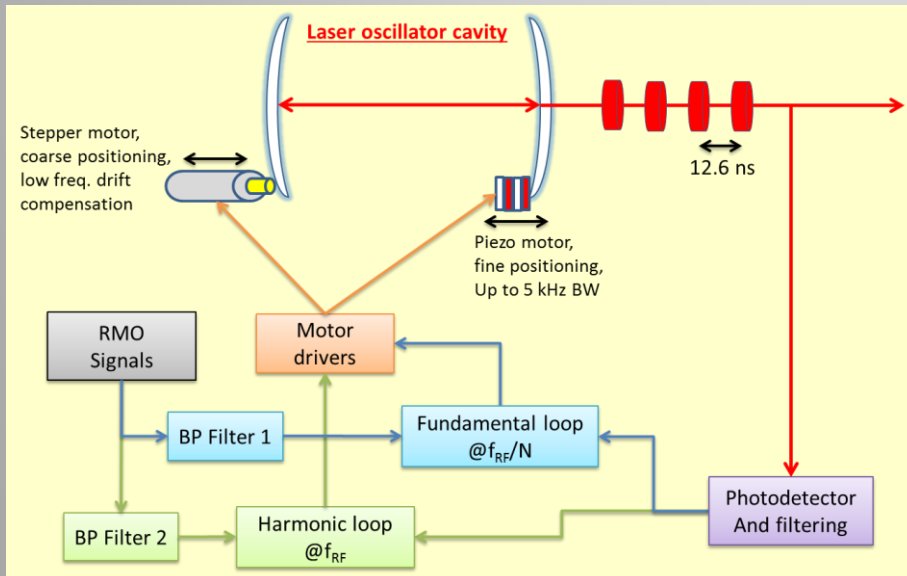

PLLs are a very general subject in RF electronics, used to **synchronize oscillators** to a **common reference** or to **extract the carrier** from a **modulated signal** (FM tuning). In our context PLLs are used to **phase-lock the clients** of the synchronization system **to the master clock** (RMO or OMO). The building blocks are:

- A VCO, whose frequency range includes $(D/N) f_{ref}$;
- A phase detector, to compare the scaled VCO phase to the reference;
- A loop filter, which sets the lock bandwidth;
- A prescalers or synthesizer (N/D frequency multiplier, N and D integers) if different frequencies are required.

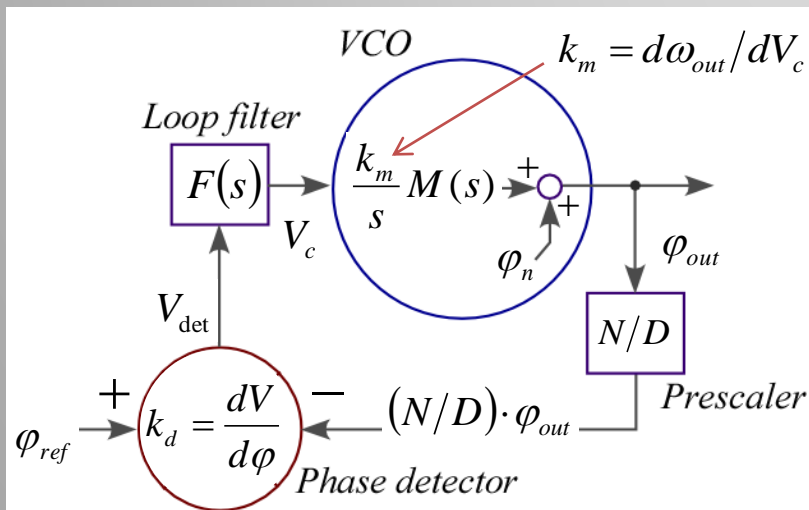
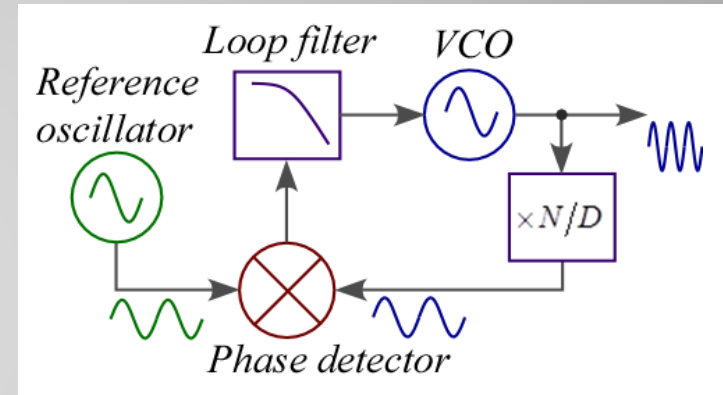

PLL linear model

PLL transfer function

$$\varphi_{out}(s) = \frac{D}{N} \frac{H(s)}{1 + H(s)} \varphi_{ref}(s) + \frac{1}{1 + H(s)} \varphi_n(s)$$

VCO noise

$$\text{with } H(s) = \frac{N}{D} \frac{k_d k_m}{s} F(s) M(s)$$

freq-to-phase conversion

loop filter

VCO mod. bandwidth

Loop filters provide **PLL stability**, tailoring the frequency response, and **set loop gain** and **cut-off frequency**.

The **output phase spectrum is locked** to the **reference** if $|H(j\omega)| \gg 1$, while it returns similar to the **free run VCO** if $|H(j\omega)| < 1$.

A flat-frequency response loop filter gives already a pure integrator loop transfer function thanks to a pole in the origin ($f=0$) provided by the dc frequency control of the VCO.

Loop filters properly designed can improve the PLL performance:

- ✓ By furtherly increasing the low-frequency gain and remove phase err. offsets due to systematic VCO frequency errors, by means of extra poles in the origin (integrators) compensated by zeroes properly placed;
- ✓ By enlarging the PLL BW through equalization of the frequency response of the VCO modulation port.

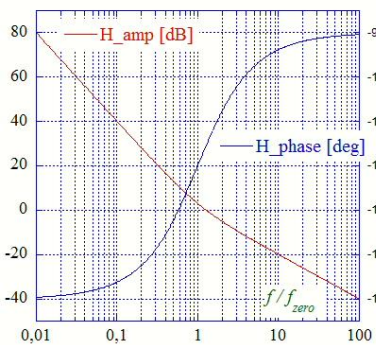
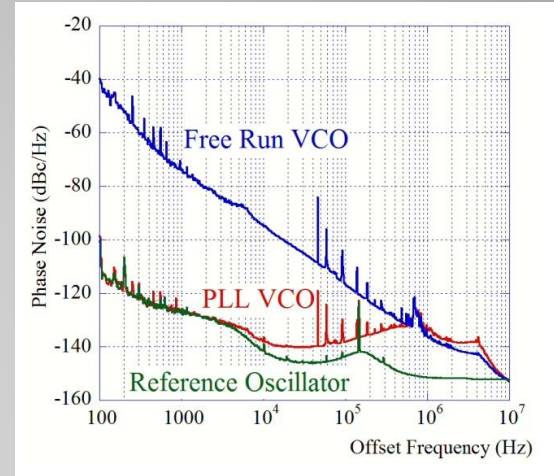

Bode plot of the PLL loop gain

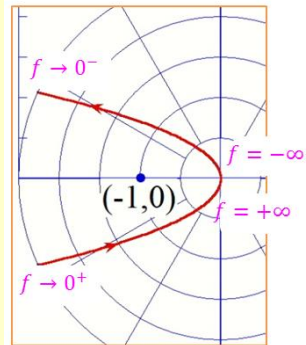

Nyquist locus

A very steep frequency response can be obtained (slope = 40 dB/decade) in stable conditions (see Nyquist plot).

Equalization of the VCO modulation port frequency response allows increasing the loop gain.

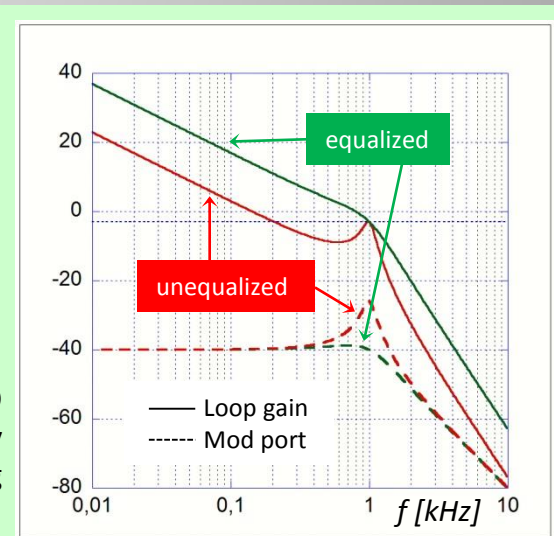

Performances of Synchronization Systems

- *Client Residual Jitter*
- *Stabilized Reference Distribution*

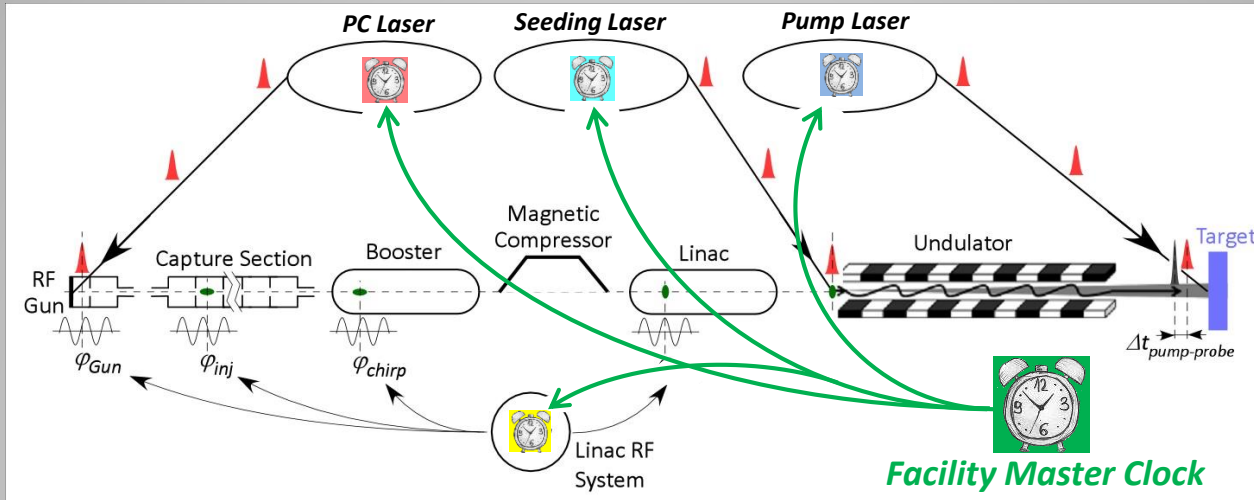

A client with a free-run phase noise φ_{i_0} once being PLL locked to the reference with a loop gain $H_i(j2\pi f)$ will show a residual phase jitter φ_i and a phase noise power spectrum S_i according to:

$$\varphi_i = \frac{H_i}{1 + H_i} \varphi_{ref} + \frac{1}{1 + H_i} \varphi_{i_0} \rightarrow S_i(f) = \frac{|H_i|^2}{|1 + H_i|^2} S_{ref}(f) + \frac{1}{|1 + H_i|^2} S_{i_0}(f)$$

Incoherent noise contributions

Client absolute residual time jitter

$$\sigma_{t_i}^2 = \frac{1}{\omega_{ref}^2} \int_{f_{min}}^{+\infty} \frac{|H_i|^2 S_{ref}(f) + S_{i_0}(f)}{|1 + H_i|^2} df$$

A. Gallo, Low Level RF challenges/timing systems

Beam Dynamics and Technologies for Future Colliders Feb.21 – March 6 2018, Zurich, CH

Client **jitters** can be reduced by **efficient PLLs** locking to a local copy of the reference.

Reference distribution **drifts** need to be **under control** to preserve a good facility synchronization.

Depending on the facility size and specification the reference distribution can be:

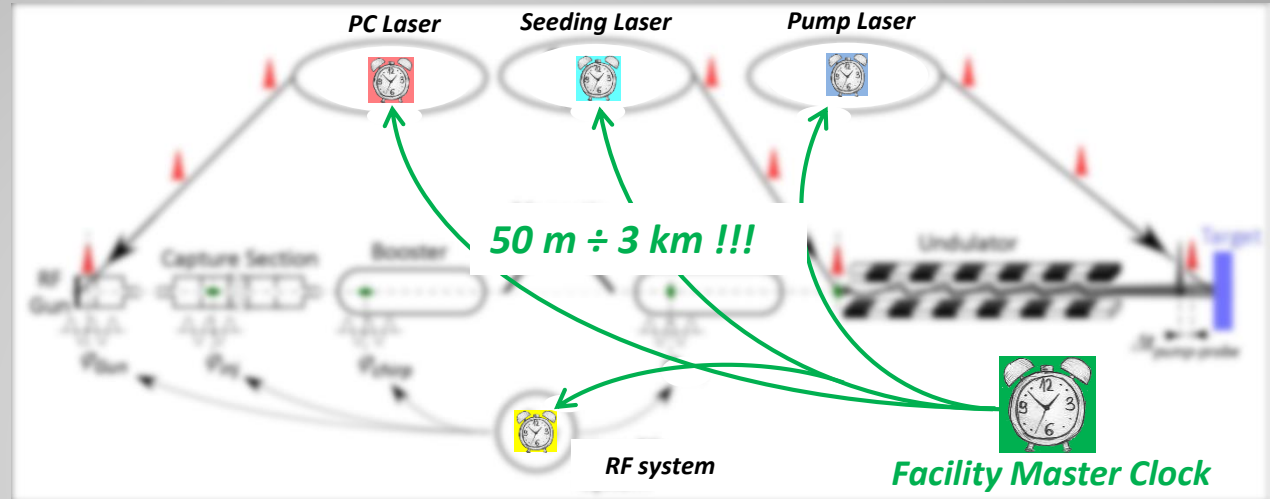

RF based, through coaxial cables

- ✓ *Passive (mainly) / actively stabilized*
- ✓ *Cheap*
- ✓ *Large attenuation at high frequencies*
- ✓ *Sensitive to thermal variations*
(copper linear expansion $\approx 1.7 \cdot 10^{-5}/^{\circ}\text{C}$)
- ✓ *Low-loss 3/8" coaxial cables very stable for $\Delta T \ll 1^{\circ}\text{C}$ @ $T_0 \approx 24^{\circ}\text{C}$*

Optical based, through fiber links

- ✓ *Pulsed (mainly), also CW AM modulated*
- ✓ *High sensitivity error detection (cross correlation, interferometry, ...)*
- ✓ *Small attenuation, large BW*
- ✓ *Expensive*
- ✓ *Active stabilization always needed (thermal sensitivity of fibers)*
- ✓ *Dispersion compensation always needed for pulsed distribution*

A. Gallo, Low Level RF challenges/timing systems
Beam Dynamics and Technologies for Future Colliders Feb.21 – March 6 2018, Zurich, CH

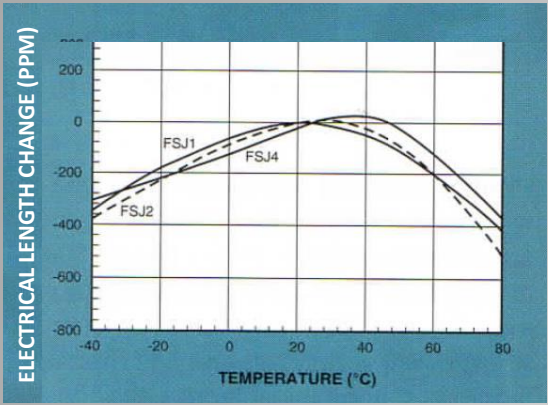

Around some optimal temperature T_{opt} cable physical elongation is compensated by dielectric constant variation. PPM relative delay variation is:

$$\left. \frac{\Delta\tau}{\tau} \right|_{PPM} \approx - \left(\frac{T - T_{opt}}{T_c} \right)^2$$

For a 3/8" cable (FSJ2): $T_{opt} \approx 24^\circ C$, $T_c \approx 2^\circ C$. Good enough?
 $L \approx 1 \text{ km} \rightarrow \tau \approx 5 \mu s \rightarrow \Delta\tau/\tau \approx 5 \text{ fs}/5 \mu s \approx 10^{-3} \text{ PPMs} !!!$

LONG DISTANCES → ACTIVE LINK STABILIZATION REQUIRED !!!

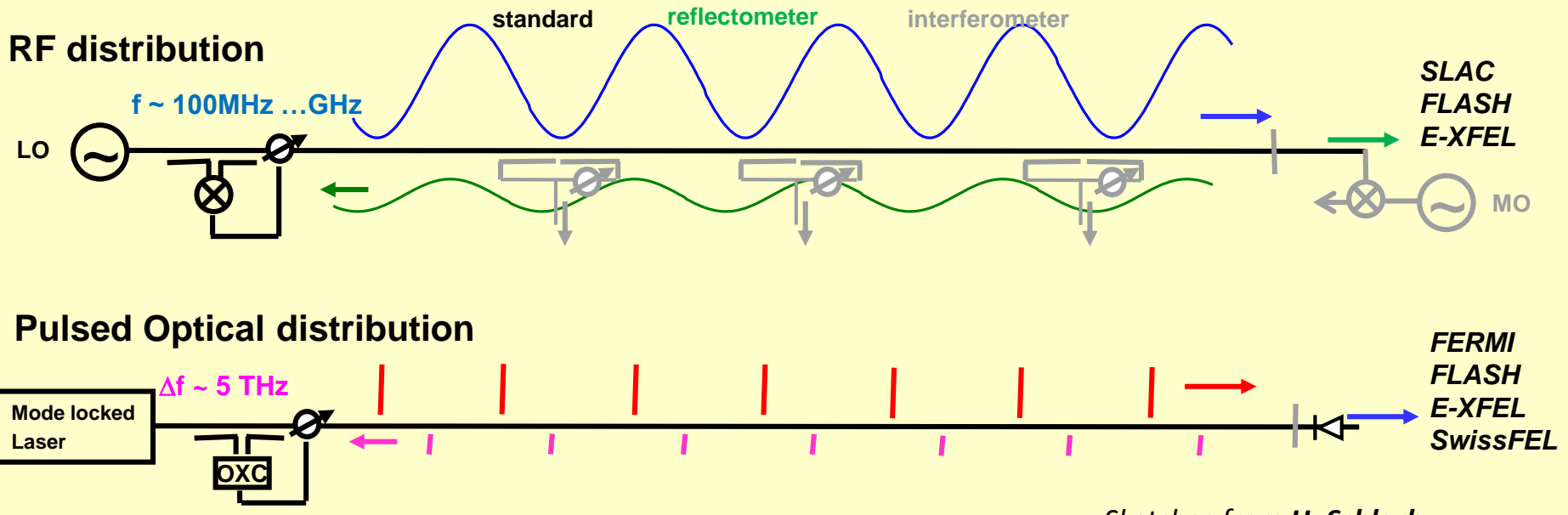

Sketches from H. Schlarb

Active stabilized links are based on high resolution *round trip time measurements* and *path length correction* to stick at some stable reference value.

Pulsed optical distribution is especially suitable, because of low signal attenuation over long links and path length monitoring through very sensitive pulse cross-correlators. However, *dispersion compensation of the link is crucial* to keep the optical pulses very short (≈ 100 fs).

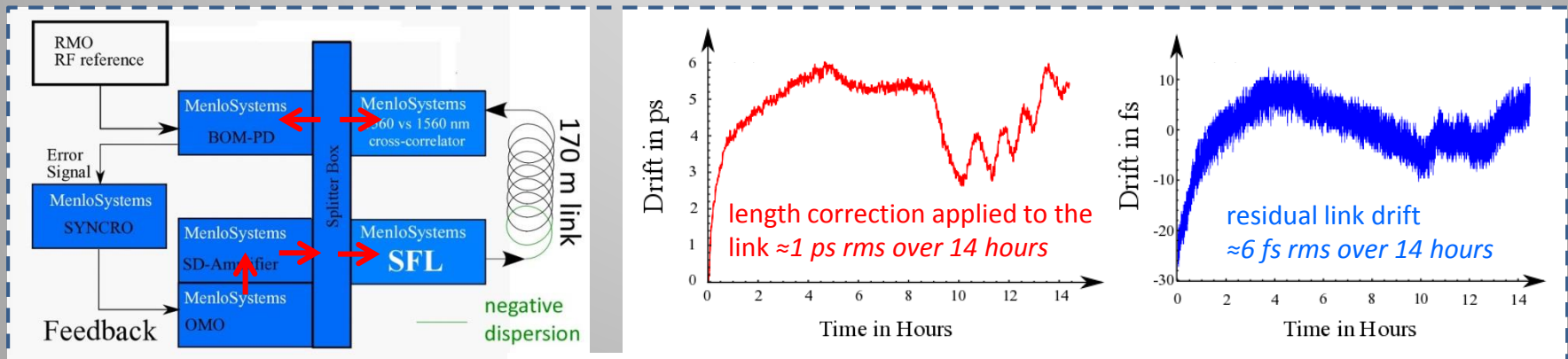
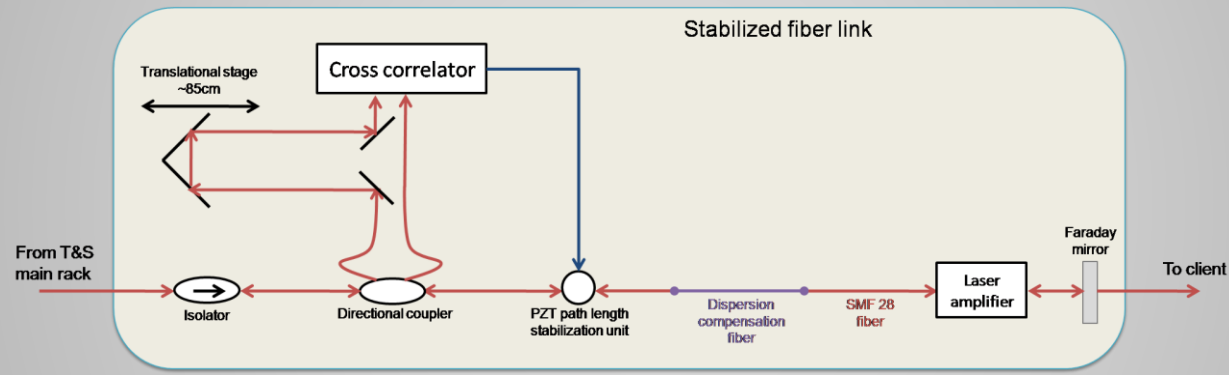

Courtesy of MenloSystems GmbH

Beam Synchronization

- *Bunch Arrival Monitors*
- *Effects of Client Synchronization Errors on Bunch Arrival Time*

RF Deflectors

A. Gallo, Low Level RF challenges/timing systems
 Beam Dynamics and Technologies for Future Colliders Feb.21 – March 6 2018, Zurich, CH

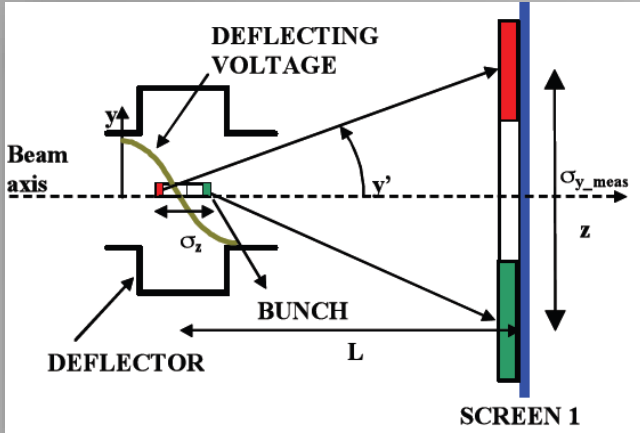

The beam is **streaked** by a **transverse RF cavity** on a **screen**. The image is captured by a camera. Longitudinal charge distribution and centroid position can be measured.

- ✓ Works typically on single bunch. Bunch trains can be eventually resolved with fast gated cameras;
- ✓ Destructive (needs a screen ...)
- ✓ Measure bunch wrt to RF (relative measurement)
- ✓ with a spectrometer → long. phase space imaging - $(z, \epsilon) \rightarrow (y, x)$

$$\tau_{res} = \frac{E/e}{\omega_{RF} V_{\perp}} \sqrt{\frac{\epsilon_{\perp}}{\beta_{\perp}^{defl}}}$$

← Achievable resolution down to ≈ 10 fs

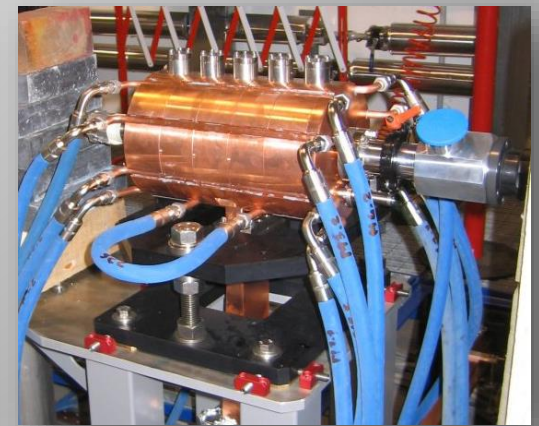
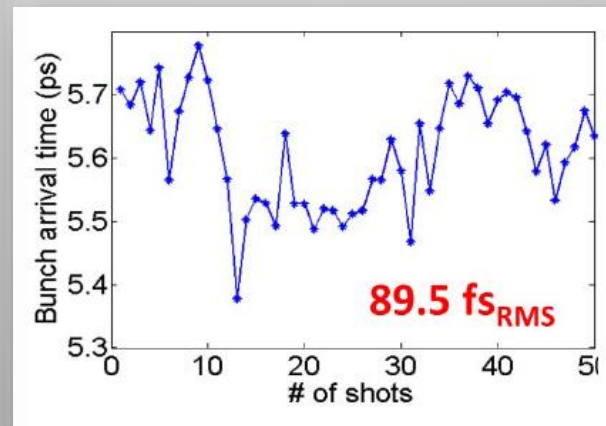
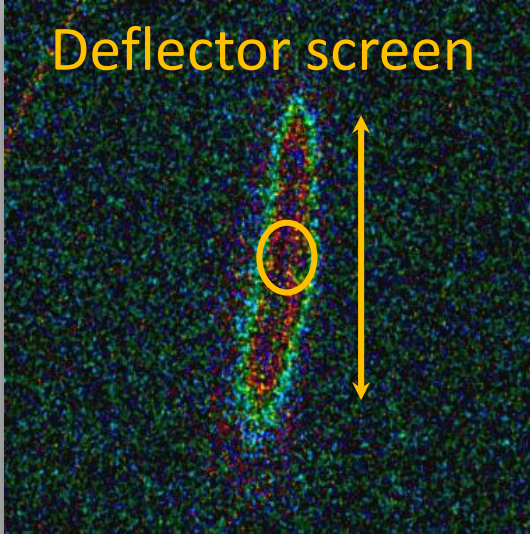

A. Gallo, Low Level RF challenges/timing systems

Beam Dynamics and Technologies for Future Colliders Feb.21 – March 6 2018, Zurich, CH

A **reference laser pulse train** (typically taken from the facility OMO) is connected to the optical input of a **Mach-Zehnder interferometric modulator (EOM)**. The short laser pulses are **amplitude-modulated** by a bipolar signal taken from a **button BPM** placed along the beam path and synchronized near to the voltage zero-crossing. **The bunch arrival time jitter and drift** is converted in **amplitude modulation** of the laser pulses and measured.

- ✓ Works very well on bunch trains;
- ✓ Non-intercepting;
- ✓ Measure bunch wrt to a laser reference (OMO);
- ✓ Demonstrated high resolution

BAM 1 – 2 placed 60 m away along the beam path

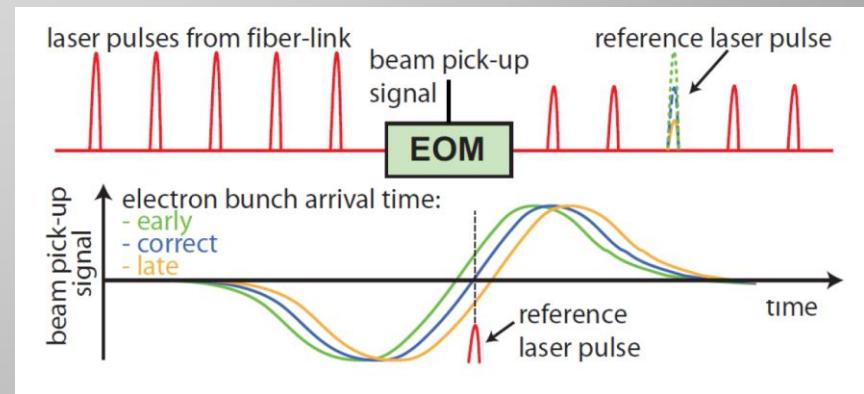
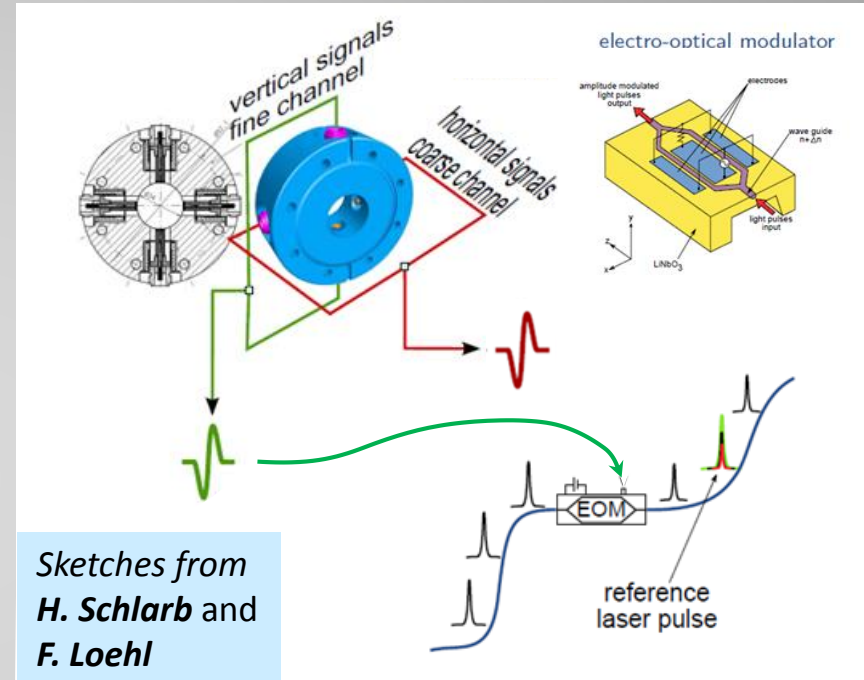
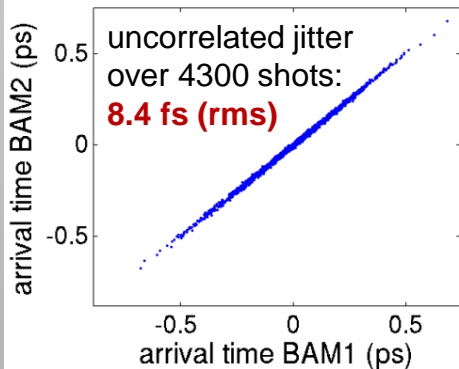

A. Gallo, Low Level RF challenges/timing systems

Beam Dynamics and Technologies for Future Colliders Feb.21 – March 6 2018, Zurich, CH

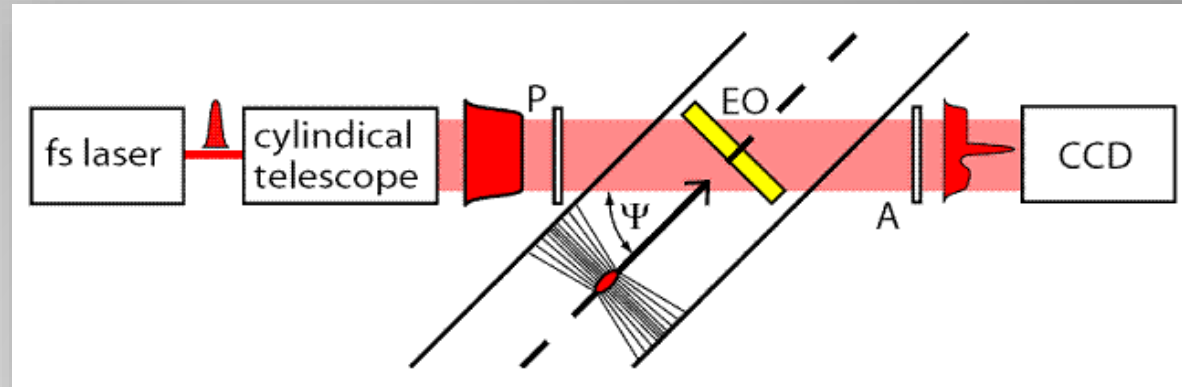
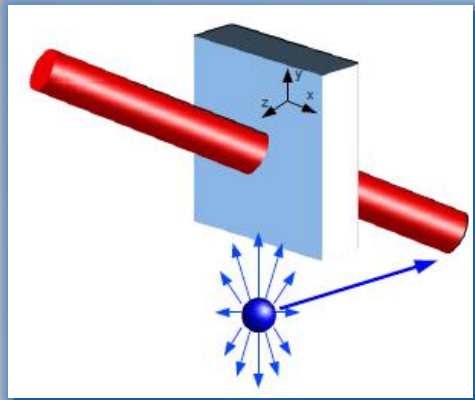

An **electro-optic crystal** is placed near the beam trajectory. In correspondence to the beam passage the crystal is illuminated with a **short reference laser pulse** transversally enlarged and **linearly polarized**. The bunch electric field induces **bi-refringence** in the crystal, so that while propagating the laser gains **elliptical polarization**. A polarized output filter delivers a signal proportional to the **polarization rotation**, i.e. to the **beam longitudinal charge distribution**.

- ✓ Single shot, non-intercepting;
- ✓ Provides charge distribution and centroid position;
- ✓ Resolution ≈ 50 fs for the bunch duration, higher for centroid arrival time (1 pixel ≈ 10 fs).

**beam ATJ vs. PC laser measured
with EOS @SPARC_LAB**

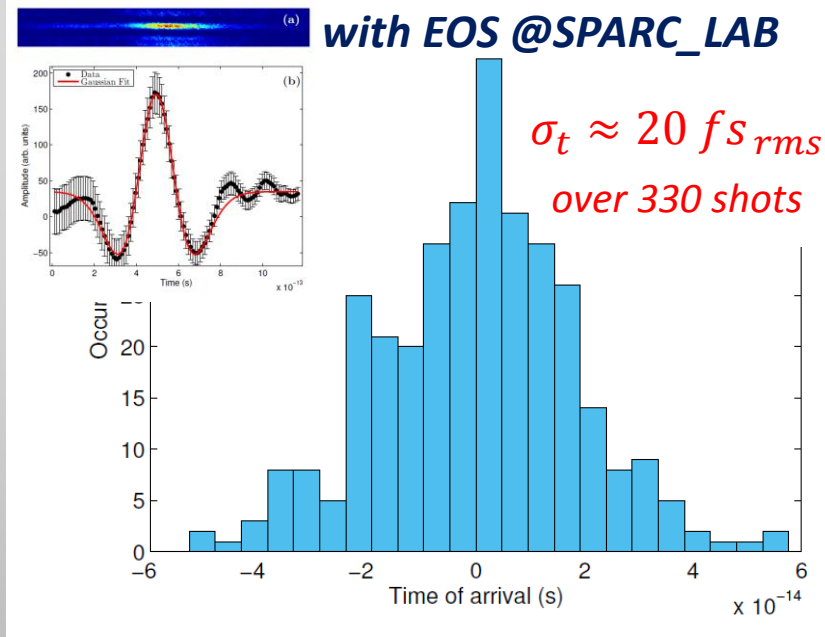

Basics of magnetic bunch compression

Energy
Time
Initial beam

head tail

sketch from Josef Frisch - SLAC

Magnetic Chicane: Higher energy particles follow a shorter path. This allows the tail to catch the head of the bunch.

Typically operate at slightly less (or more) than full compression

Energy chirp h :

$$W_0 = W_{in} + qV_{RF} \cos(\varphi_0)$$

Final energy error of an accelerated particle starting with energy and phase errors ΔW_{in} and $\Delta\varphi$

$$\Delta W_0 = \Delta W_{in} - qV_{RF} \sin(\varphi_0) \Delta\varphi = \Delta W_{in} + h \frac{c}{\omega_{RF}} W_0 \Delta\varphi$$

with

$$h \stackrel{\text{def}}{=} \frac{\Delta W / W_0}{\Delta z} = \frac{\omega_{RF}}{c} \frac{\Delta W / W_0}{\Delta\varphi} = \frac{-qV_{RF} \sin(\varphi_0)}{W_{in} + qV_{RF} \cos(\varphi_0)} \frac{\omega_{RF}}{c}$$

chirp coefficient = relative energy deviation normalized to the particle z position

Non-isochronous transfer line:

The bunch compression process is completed by making the chirped beam travel along a non-isochronous transfer line. Particles with different energies travel along paths of different lengths according to:

$$\Delta L = R_{56}(\Delta W_0/W_0)$$

Path elongation normalized to the relative energy error

Overall, a particle entering the magnetic compressor with a time error Δt_{in} and a relative energy error $\Delta W_{in}/W_{in}$ will leave it with time and relative energy errors $\Delta W_0/W_0$ and Δt_o given by:

$$\Delta W_0/W_0 = hc \Delta t_{in} + \frac{W_{in}}{W_0} \Delta W_{in}/W_{in}$$

$$\Delta t_o = \Delta t_{in} + \frac{\Delta L}{c} = \Delta t_{in} + \frac{R_{56}}{c} (\Delta W_0/W_0) = (1 + h R_{56}) \Delta t_{in} + \frac{R_{56}}{c} \frac{W_{in}}{W_0} (\Delta W_{in}/W_{in})$$

In the end if the compressor is tuned to get $h \cdot R_{56} \approx -1$ it may easily noticed that the exit time of a particle is almost independent on the entering time. This mechanism describes the deformation (compression) of the longitudinal distribution of the particles in a bunch, **but also the multi-shot dynamics of the bunch longitudinal centroid. The bunch arrival time downstream the compressor is weakly related to the upstream arrival time.**

Compressor longitudinal transfer matrices:

Previous results can be summarized in a matrix notation, according to:

$$\begin{pmatrix} \Delta t \\ \Delta W/W \end{pmatrix}_o = \begin{bmatrix} 1 & \frac{R_{56}}{c} \\ 0 & 1 \end{bmatrix} \begin{bmatrix} 1 & 0 \\ hc & \frac{W_{in}}{W_0} \end{bmatrix} \begin{pmatrix} \Delta t \\ \Delta W/W \end{pmatrix}_{in} = \begin{bmatrix} 1 + hR_{56} & \frac{R_{56}}{c} \frac{W_{in}}{W_0} \\ hc & \frac{W_{in}}{W_0} \end{bmatrix} \begin{pmatrix} \Delta t \\ \Delta W/W \end{pmatrix}_{in}$$

\hat{B}

non-isochronous drift

\hat{A}

chirping acceleration

$\hat{C} = \hat{B} \cdot \hat{A}$

total compressor stage

Effects of PM and AM in the compressor RF on final bunch energy and arrival time:

Let's consider now the presence of phase ($\Delta\varphi_o = -\omega_{RF}\Delta t_{RF}$) and amplitude ($\Delta V_{RF}/V_{RF}$) errors in the RF section of the compressor. The resulting energy error of the beam entering in the non-isochronous drift is:

$$\Delta W_o = q\Delta V_{RF}\cos(\varphi_o) - qV_{RF}\sin(\varphi_o)\Delta\varphi_o$$

$$\frac{\Delta W_o}{W_o} = -hc\Delta t_{RF} + \frac{W_o - W_{in}}{W_o} \frac{\Delta V_{RF}}{V_{RF}}$$

The energy error will result in a time error downstream the drift through the transfer matrix \hat{B} .

$$\begin{pmatrix} \Delta t \\ \Delta W/W \end{pmatrix}_o = \begin{bmatrix} 1 & \frac{R_{56}}{c} \\ 0 & 1 \end{bmatrix} \begin{bmatrix} 0 & 0 \\ -hc & \frac{W_o - W_{in}}{W_o} \end{bmatrix} \begin{pmatrix} \Delta t_{RF} \\ \Delta V_{RF}/V_{RF} \end{pmatrix} = \begin{bmatrix} -hR_{56} & \frac{R_{56}}{c} \frac{W_o - W_{in}}{W_o} \\ -hc & \frac{W_o - W_{in}}{W_o} \end{bmatrix} \begin{pmatrix} \Delta t_{RF} \\ \Delta V_{RF}/V_{RF} \end{pmatrix}$$

\hat{B}

non-isochronous drift

\hat{N}

RF noise-to-energy

$\hat{R} = \hat{B} \cdot \hat{N}$

RF AM&PM conversion to bunch time and energy

BC block diagram:

To the first order the RF noise does not affect the bunch internal distribution, since RF amplitude and phase does not change significantly over a bunch time duration. It will more affect the bunch-to-bunch energy deviation and arrival time.

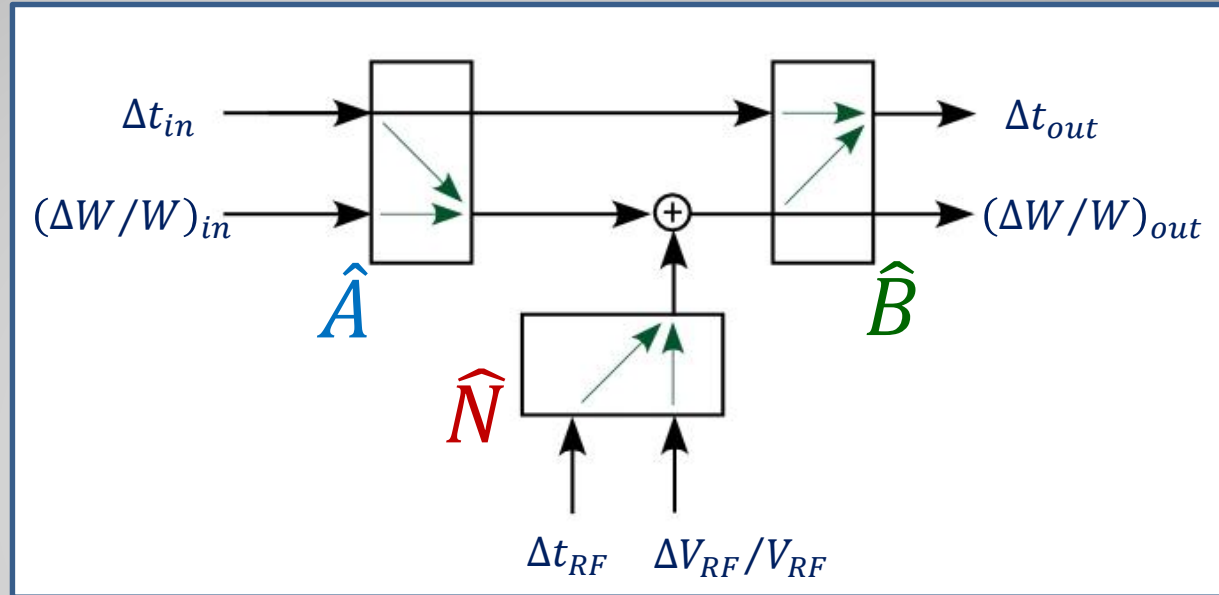

$$\begin{pmatrix} \Delta t \\ \Delta W/W \end{pmatrix}_0 = \hat{B} \left[\hat{A} \begin{pmatrix} \Delta t \\ \Delta W/W \end{pmatrix}_{in} + \hat{N} \begin{pmatrix} \Delta t_{RF} \\ \Delta V_{RF}/V_{RF} \end{pmatrix} \right]$$

$$\Delta t_0 = \overset{\approx 0}{(1 + hR_{56})} \Delta t_{in} - \overset{\approx 1}{hR_{56}} \Delta t_{RF} + \frac{R_{56}}{c} \frac{W_{in}}{W_0} (\Delta W/W)_{in} + \frac{R_{56}}{c} \frac{W_0 - W_{in}}{W_0} (\Delta V_{RF}/V_{RF})$$

The bunch arrival time downstream the compressor is strongly related to the phase of the chirping RF. It is also affected by initial energy errors and RF amplitude variations.

How beam arrival time is affected by synchronization errors of the sub-systems?

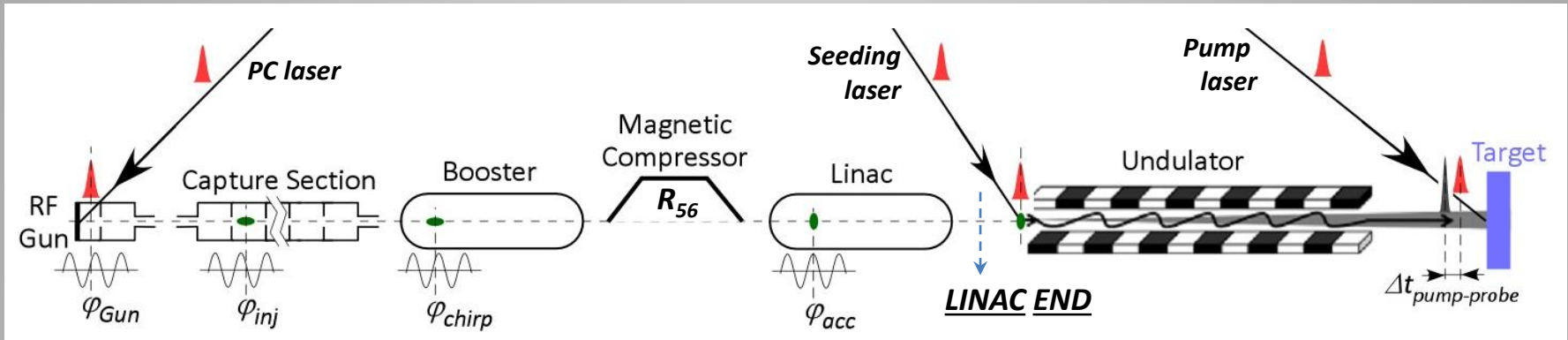

Perfect synchronization → the time (or phase) T_i of all sub-systems properly set to provide required beam characteristics at the Linac end, where the bunch centroid arrives at time T_b .

Perturbations of subsystem phasing Δt_i will produce a change Δt_b of the beam arrival time.

First-order approximation:

$$\Delta t_b = \sum_i a_i \Delta t_i = \sum_i \frac{\Delta t_i}{c_i} \quad \text{with} \quad \sum_i a_i = 1$$

Compression coefficients

Values of a_i can be computed analytically, by simulations or even measured experimentally. They very much depends on the machine working point.

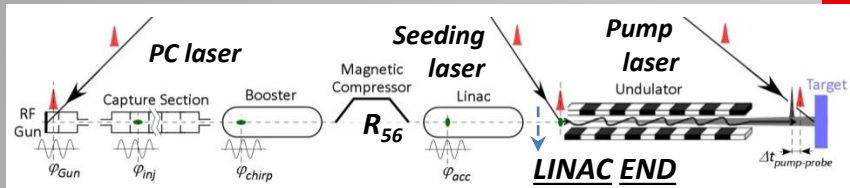

How beam arrival time is affected by synchronization errors of the sub-systems?

- ✓ No compression: Beam captured by the GUN and accelerated on-crest

$$a_{PC} \approx 0.7 ; \quad a_{RF_{GUN}} \approx 0.3 ; \quad \text{others } a_i \approx 0$$

- ✓ Magnetic compression: Energy-time chirp imprinted by off-crest acceleration in the booster and exploited in magnetic chicane to compress the bunch

$$a_{RF_{boost}} \approx 1 ; \quad |a_{PC}| \ll 1 ; \quad \text{others } a_i \approx 0$$

Compression can be staged (few compressors acting at different energies). Bunch can be overcompressed (head and tail reversed, $a_{PC} < 0$).

- ✓ RF compression: a non fully relativistic bunch ($E_0 \approx \text{few MEV}$ at Gun exit) injected ahead the crest in an RF capture section slips back toward an equilibrium phase closer to the crest during acceleration, being also compressed in this process

$$a_{RF_{CS}} \approx 1 ; \quad |a_{PC}|, |a_{RF_{GUN}}| \ll 1 ; \quad \text{others } a_i \approx 0$$

The bunch gains also an Energy-time chirp. RF and magnetic compressions can be combined.

Particle distribution within the bunch and shot-to-shot centroid distribution behave similarly, but values of coefficients a_i might be different since space charge affects the intra-bunch longitudinal dynamics.

Bunch Arrival Time Jitter

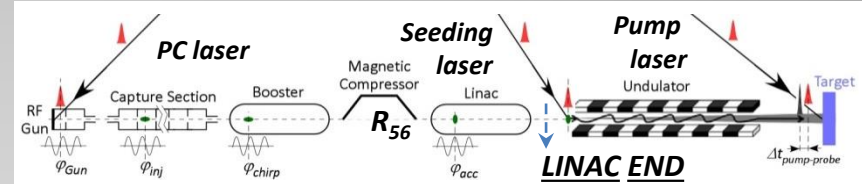

If we consider uncorrelated residual jitters of Δt_i (measured wrt the facility reference clock), the bunch arrival time jitter σ_{t_b} is given by:

$$\sigma_{t_b}^2 = \sum_i a_i^2 \sigma_{t_i}^2$$

while the jitter of the beam respect to a specific facility sub-system (such as the PC laser or the RF accelerating voltage of a certain group of cavities) $\sigma_{t_{b-j}}$ is:

$$\sigma_{t_{b-j}}^2 = (a_j - 1)^2 \sigma_{t_j}^2 + \sum_{i \neq j} a_i^2 \sigma_{t_i}^2$$

EXAMPLE: PC laser jitter $\sigma_{t_{PC}} \approx 70 \text{ fs}$, RF jitter $\sigma_{t_{RF}} \approx 30 \text{ fs}$

No Compression: $a_{PC} \approx 0.65$, $a_{RF_{GUN}} \approx 0.35$

$$\sigma_{t_b} \approx 47 \text{ fs}$$

$$\sigma_{t_{b-PC}} \approx 27 \text{ fs}; \sigma_{t_{b-RF}} \approx 50 \text{ fs}$$

Magnetic Compression: $a_{PC} \approx 0.2$, $a_{RF_{boost}} \approx 0.8$

$$\sigma_{t_b} \approx 28 \text{ fs}$$

$$\sigma_{t_{b-PC}} \approx 61 \text{ fs}; \sigma_{t_{b-RF}} \approx 15 \text{ fs}$$

- ✓ Timing and Synchronization has growth considerably in the last ~ 15 years as a Particle Accelerators specific discipline
- ✓ It involves concepts and competences from various fields such as Electronics, RF, Laser, Optics, Control, Diagnostics, Beam dynamics, ...
- ✓ Understanding the real synchronization needs of a facility and proper specifications of the systems involved are crucial for successful and efficient operation (but also to avoid overspecification leading to extra-costs and unnecessary complexity ...)
- ✓ Synchronization diagnostics (precise arrival time monitors) is fundamental to understand beam behavior and to provide input data for beam-based feedback systems correcting synchronization residual errors
- ✓ Although stability down to the fs scale has been reached, many challenges still remain since requirements get tighter following the evolution of the accelerator technology. The battleground will move soon to the attosecond frontier ... (see A. Ferran Pousa et al 2017 *J. Phys.: Conf. Ser.* 874 012032)

A. Gallo, *Low Level RF challenges/timing systems*
Beam Dynamics and Technologies for Future Colliders Feb.21 – March 6 2018, Zurich, CH

- F. Loehl, *Timing and Synchronization*, Accelerator Physics (Intermediate level) – Chios, Greece, 18 - 30 September 2011 – slides on web
- H. Schlarb, *Timing and Synchronization*, Advanced Accelerator Physics Course – Trondheim, Norway, 18– 29 August 2013 - slides on web
- M. Bellaveglia, *Femtosecond synchronization system for advanced accelerator applications*, IL NUOVO CIMENTO, Vol. 37 C, N. 4, 10.1393/ncc/i2014-11815-2
- E. Rubiola, *Phase Noise and Frequency Stability in Oscillators*, Cambridge University Press
- E. Rubiola, R. Boudot, *Phase Noise in RF and Microwave Amplifiers*, slides @ [http://www.ieee-uffc.org/frequency-control/learning/pdf/Rubiola-Phase Noise in RF and microwave amplifiers.pdf](http://www.ieee-uffc.org/frequency-control/learning/pdf/Rubiola-Phase%20Noise%20in%20RF%20and%20microwave%20amplifiers.pdf)
- O. Svelto, *Principles of Lasers*, Springer
- R.E. Collin, *Foundation for microwave engineering*, Mc Graw-Hill int. editions
- H.Taub, D.L. Schilling, *Principles of communication electronics*, Mc Graw-Hill int. student edition
- J. Kim et al., *Long-term stable microwave signal extraction from mode-locked lasers*, 9 July 2007 / Vol. 15, No. 14 / OPTICS EXPRESS 8951
- T. M. Hüning et al., *Observation of femtosecond bunch length using a transverse deflecting structure*, Proc of the 27th International Free Electron Laser Conference (FEL 2005), page 538, 2005.
- R. Schibli et al., *Attosecond active synchronization of passively mode-locked lasers by balanced cross correlation*, Opt. Lett. 28, 947-949 (2003)
- F. Loehl et al., *Electron Bunch Timing with Femtosecond Precision in a Superconducting Free-Electron Laser*, Phys. Rev. Lett. 104, 144801
- I. Wilke et al., *Single-shot electron-beam bunch length measurements*, Physical review letters, 88(12) 124801, 2002

A. Gallo, *Low Level RF challenges/timing systems*
Beam Dynamics and Technologies for Future Colliders Feb.21 – March 6 2018, Zurich, CH

- S. Schulz et al., *An optical cross-correlator scheme to synchronize distributed laser systems at FLASH*, THPC160, Proceedings of EPAC08, Genoa, Italy
- M. K. Bock, *Recent developments of the bunch arrival time monitor with femtosecond resolution at FLASH*, WEOCMH02, Proceedings of IPAC'10, Kyoto, Japan
- R. Pompili et al., *Femtosecond timing-jitter between photo-cathode laser and ultra-short electron bunches by means of hybrid compression*, New Journal of Physics, Volume 18, August 2016
- <http://www.onefive.com/ds/Datasheet%20Origami%20LP.pdf>
- E5052A signal source analyzer, <http://www.keysight.com/en/pd-409739-pn-E5052A/signal-source-analyzer-10-mhz-to-7-265-or-110-ghz?cc=IT&lc=ita>
- Menlo Systems GMBH: <http://www.menlosystems.com/products/?families=79>
- Andrew cables: http://www.commscope.com/catalog/wireless/product_details.aspx?id=1344
- <http://www.nist.gov/>
- <http://www.thinksrs.com/index.htm>
- <http://www.mrf.fi/>
- <http://www.sciencedirect.com/science/article/pii/S0168583X13003844>
- <http://spie.org/Publications/Proceedings/Paper/10.1117/12.2185103>
- A Ferran Pousa et al 2017 J. Phys.: Conf. Ser. 874 012032