



## HL-LHC AUP in US after CD-1: Status and Goals at 7<sup>th</sup> HL-LHC Collaboration Meeting

Giorgio Apollinari

CIEMAT, Madrid, Spain – Nov 13<sup>th</sup>, 2017



# Content

- HL-LHC Status: Critical Decision #1
  - CD-1 Review
  - Response to CD-1 Reviews
- Documentations and Goals for this Collaboration Meeting
  - DOE-mandated Reviews
  - Specifications, Parts Exchange, Acceptance, Agreements and all that !
- AUP Technical Status
- LARP

# DOE Inputs

## DOE HL-LHC Project Schedules

### HL-LHC Accelerator Upgrade Project

- DOE CD-1/CD-3a (Long-lead Procurement) Reviews held in August 2017 went well; DOE CD-1/CD-3a approved in October 2017
- Project is advanced technically and management team is transitioning well from the LARP R&D mode to DOE project execution with a strong project office at Fermilab
- Project likely to go for CD-2 (Project Baseline) in the second half of 2018

### HL-LHC ATLAS and CMS Detector Upgrade Projects

- Finalizing resource-loaded schedules, including scope contributions and contingency estimations
- DOE working with U.S. ATLAS (BNL) and U.S. CMS (Fermilab) project offices to understand funding profiles in preparation for next DOE CD-1 milestone, which is planned for spring 2018

## Overall HEP Budget Trend

- P5 strategy continues to define investments in future of the field
- Current draft of the U.S. House of Representatives FY 2018 appropriations bill is flat with respect to FY 2017, while the U.S. Senate draft bill is slightly up

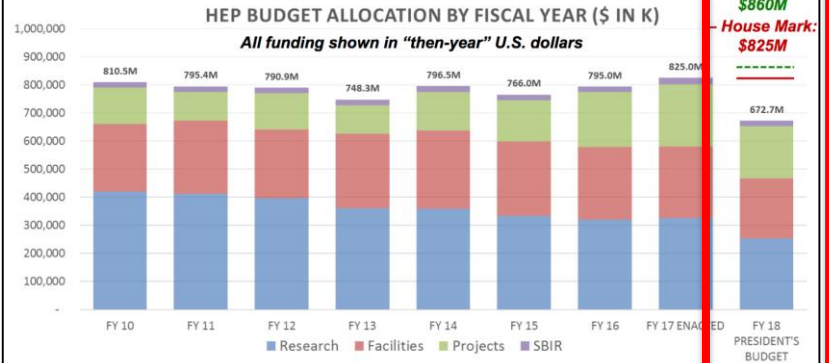

## Closing Summary

- CERN-DOE partnership strong and growing
- LHC program at CERN across three fronts: upgrades, operations, research
  - HL-LHC Accelerator Upgrade and HL-LHC ATLAS and CMS Detector Upgrade projects are ramping up
  - Will continue to support LHC detector operations: future computing models are under study
  - Research funding will continue to be constrained in current fiscal environment
  - U.S. hosted neutrino program is progressing with LBNF/DUNE and PIP-II
  - Far-site civil construction has begun; International interest is ramping up
  - DUNE is on-track for technical component construction beginning in 2019
- HL-LHC and LBNF/DUNE are the two large projects called out in the P5 strategy – we are well on our way!

Abid Patwa at  
2017 USLUA

# HL-LHC Accelerator Upgrade Project

- HL-LHC AUP is a formal DOE Construction Project
- A DOE construction project is governed by DOE Order 413.3B
- DOE projects typically progress through five Critical Decision (CD) gateways, which serve as major milestones
  - Each CD marks an authorization to increase the commitment of resources by DOE and requires successful completion of the preceding phase or CD
    - ✓ CD-0: Mission Need Approved Apr '16
    - ✓ CD-1: Alternative Selection and Cost range Approved Oct '17 ! (also CD-3a)
    - CD-2: Baseline Approval Planned for late FY18
    - CD-3: Construction Approval Phased in late FY18 and FY20
    - CD-4: Project Complete
- A typical CD-x process involves:
  - External reviews run by the Project
  - "CD-x Director Review" run by the FNAL Director Jun. '17
  - "CD-x IPR" run by DOE Aug. '17
  - Approval by ESAAB Oct. '17
  - Spending Authority finally comes from Congress approval of the Budget

# Obtained AUP CD-1 ESAAB Approval on Oct. 13<sup>th</sup> 2017 !

- Thanks to FPD (Jerry Kao) !
  - Cost Range: 209 M\$ to 252 M\$
  - Schedule Range: 3QFY28 with 36 months float

**Critical Decision 1/3a**  
**Approve Alternative Selection and Cost Range/Long-Lead Procurement**  
**of the**  
**High Luminosity LHC Accelerator Upgrade Project (HL-LHC AUP)**  
 (MIE Project)  
**at the**  
**Fermi National Accelerator Laboratory**  
 Office of High Energy Physics

**Purpose**

The purpose of this paper is to document the review at the Systems Acquisition Advisory Board-equivalent for Alternative Selection and Cost Range/Long-Lead Procurement of the High Luminosity LHC Accelerator Upgrade Project (HL-LHC AUP) at the Fermi National Accelerator Laboratory (Fermilab).

**Project Overview**

The mission of the High Energy Physics (HEP) program is to explore the universe works at its most fundamental level by discovering and understanding the interactions between them. Our current understanding of the elementary particles and forces that govern the universe is based on the Standard Model of particle physics, which describes the interactions of the particles that comprise ordinary matter and the forces that govern them.

The experimental HEP program is focused on three main areas: Intensity, and Cosmic Frontiers. At the Energy Frontier, new particles, reveal their interactions, and invest in supported Energy Frontier facility presently operating at the Large Hadron Collider (LHC) at CERN, the European Organization for Nuclear Research (CERN) in Switzerland and France. CERN is the largest particle physics laboratory in the world, with twenty-one Member States. In May 2015, CERN and the U.S. Department of Energy signed a new Memorandum of Understanding (MOU) that renewed the framework for U.S. participation in the LHC program, with particular emphasis on the plans for the High Luminosity LHC (HL-LHC) upgrade. The HL-LHC upgrade was followed by the signature of a new Memorandum of Understanding (MOU) agreement further specifying the HL-LHC Upgrade at Fermilab.

The DOE HEP program originally supported the development of the superconducting dipole and quadrupole magnet systems and ATLAS detectors collision points. The LHC succeeded in 2012 at center-of-mass energies of 7-8 TeV, reaching luminosities of  $7.7 \times 10^{33} \text{ cm}^{-2}\text{s}^{-1}$  and resumed operations in 2015 at luminosities of  $2-3 \times 10^{34} \text{ cm}^{-2}\text{s}^{-1}$  through the HL-LHC upgrade.

CERN is now planning a High Luminosity upgrade of the LHC in the middle of the next decade with levelled luminosities.

**Critical Decision 1/3a. Approve Alternate Selection and Cost Range and Long-Lead Procurement of the HL-LHC AUP Project**

**Recommendations**

The undersigned "Do Recommend" (Yes) or "Do Not Recommend" (No) approval of CD-1/3a, Approve Alternate Selection and Cost Range and Long Lead Procurement, for the HL-LHC AUP Project at Fermilab as noted below.

[Signature] 10/10/17 Yes  No   
 ESAAB Secretariat, Office of Project Assessment Date

\_\_\_\_\_  
 Representative, Office of Budget Date Yes  No

[Signature] \_\_\_\_\_ Date Yes  No   
 Representative, Environment, Safety and Health Date

[Signature] 10/13/17 Yes  No   
 Representative, Safety and Security Policy (Security) Date

[Signature] 10/13/17 Yes  No   
 Representative, Operations Program Management (Facilities and Infrastructure) Date

[Signature] \_\_\_\_\_ Date Yes  No   
 Representative, Non-Proponent SC Program Office Date

[Signature] 10/13/17 Yes  No   
 Representative, Non-Proponent Federal Project Director Date

**Approval**

Based on the information presented above and at this review, Critical Decision-1/3a, Approve Alternative Selection and Cost Range for the HL-LHC AUP, is approved.

[Signature] 10 Oct 17  
 J. Stephen Binkley, Project Management Executive  
 Acting Director Date  
 Office of Science



Preliminary Project  
 for  
**US HL-LHC Accelerator Upgrade Project**  
 MIE  
 Fermi National Accelerator Laboratory  
 Office of High Energy Physics  
 U.S. Department of Energy  
 September 2017

**Submitted by:**

[Signature] 9/20/17  
 Giorgio Apollinari  
 HL-LHC AUP Project Manager  
 Fermi National Accelerator Laboratory

[Signature] 9/27/17  
 C. Jerry Kao  
 HL-LHC AUP  
 Federal Project Director  
 Fermi Site Office

[Signature] 9/27/17  
 Simone Rossi  
 HL-LHC AUP Federal  
 Program Manager  
 Office of High Energy Physics  
 Office of Science

[Signature] 10/2/17  
 James L. Siegrist  
 Associate Director for High Energy Physics  
 Office of Science

**Concurrence:**

[Signature] 10/11/17  
 Stephen W. Meador  
 Director  
 Office of Project Assessment  
 Office of Science

**Approval:**

[Signature] 10/13/17  
 J. Stephen Binkley  
 Deputy Director for Science Programs  
 Office of Science

[Signature] 9/26/17  
 Nigel S. Lockyer  
 Director  
 Fermi National Accelerator Laboratory

[Signature] 9/27/2017  
 Michael J. Weiss  
 Site Manager  
 Fermi Site Office



# Preliminary U.S. contributions to HL-LHC (in pictures)

Insertion Region layout from the IP to Q4

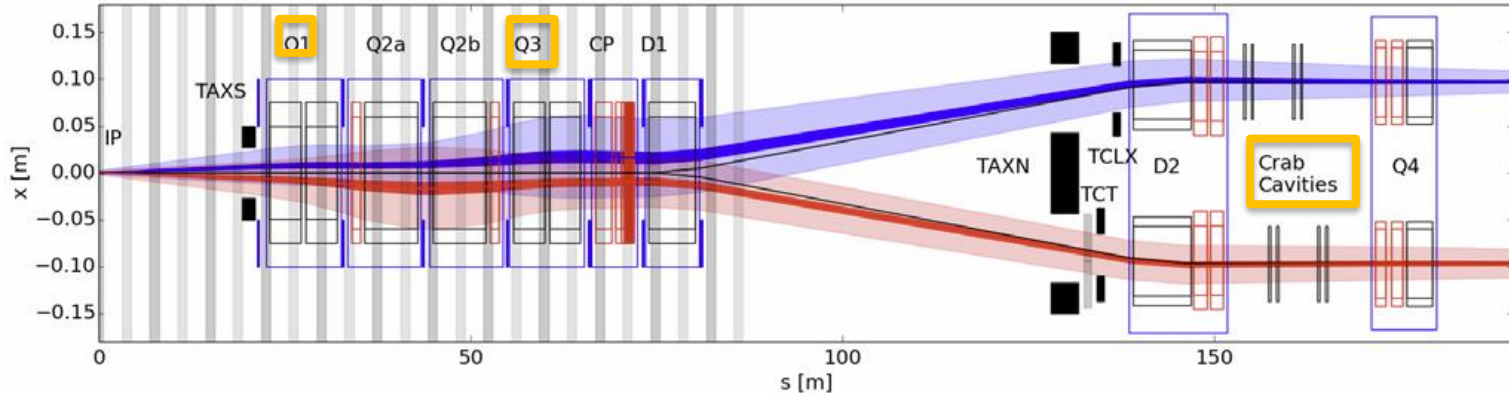

## Large Aperture IR Quadrupoles:

- From 70 mm MQXA/B to 150 mm MQXF
- From NbTi to Nb<sub>3</sub>Sn for higher field/gradient
- Minimum  $\beta^*$  from 0.55 m to 0.15 m
- Compatible with 10x integrated luminosity

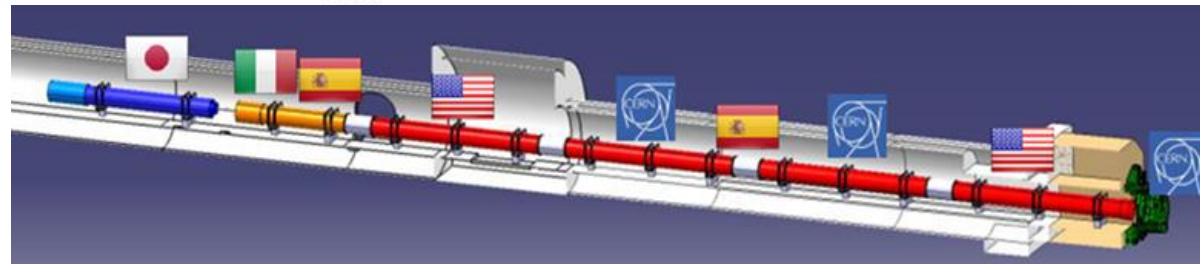

## Crab cavities:

- Deflect bunch at IP to collide head-on
- Restore luminosity loss due to crossing angle
- Requires compact superconducting cavities

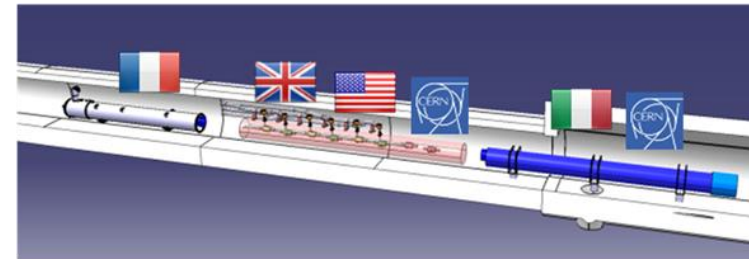
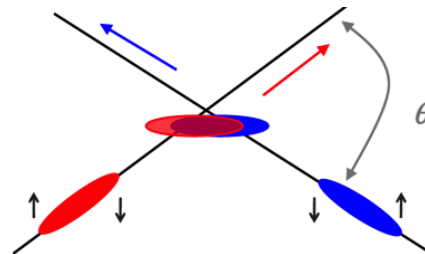

# Preliminary U.S. contributions to HL-LHC (in pictures)

- Q1/Q3 Cryoassembly

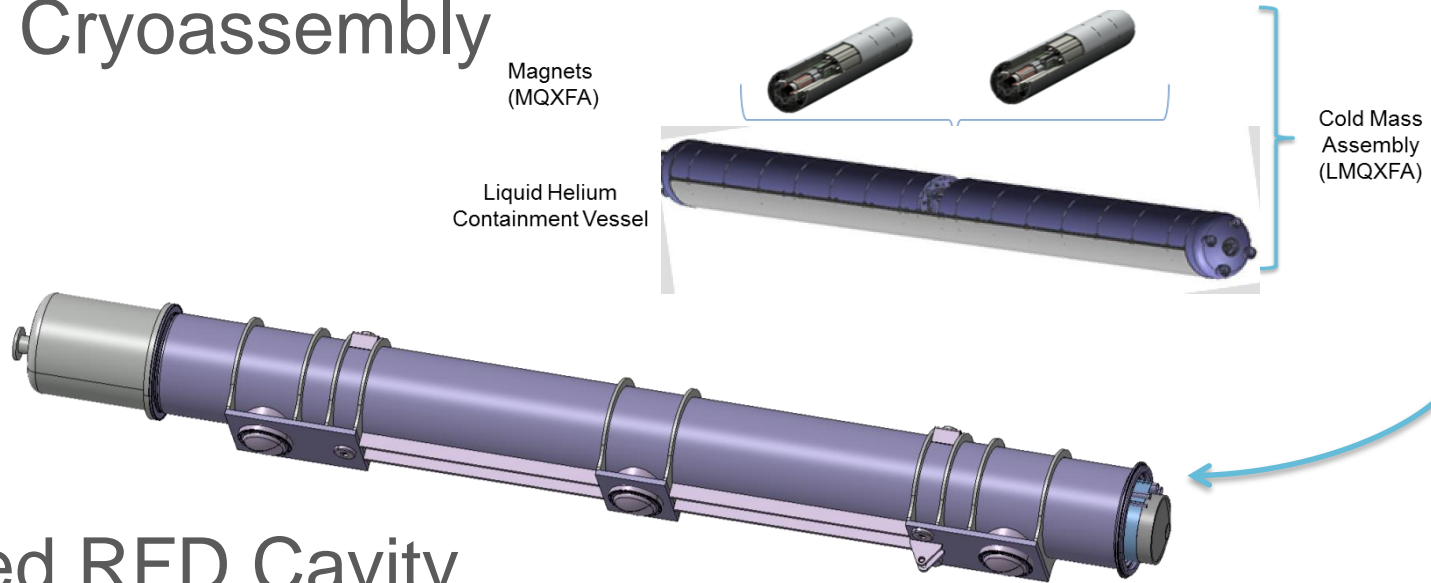

- Dressed RFD Cavity

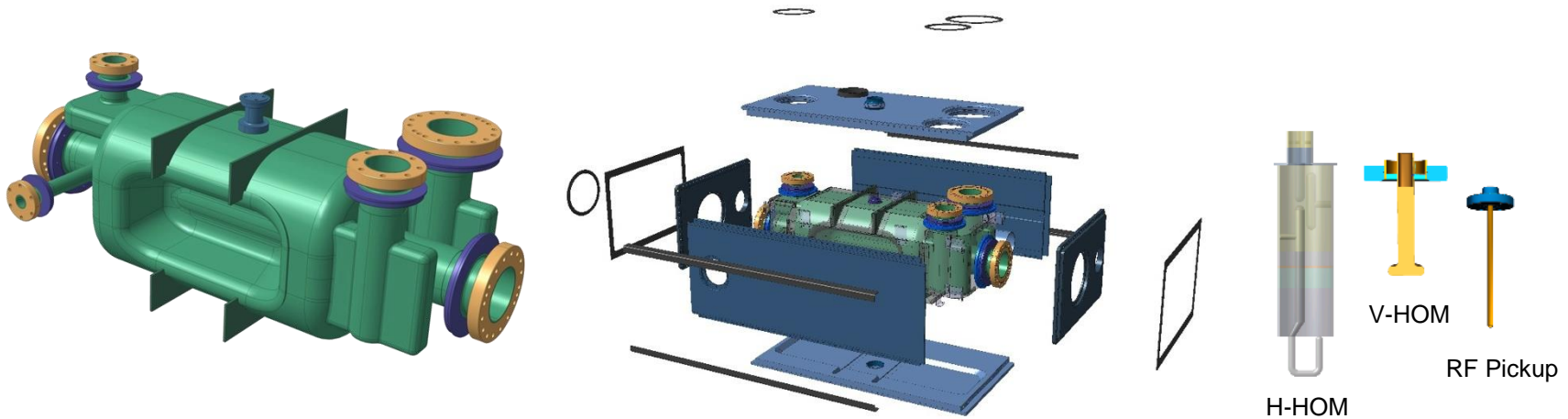

# Preliminary U.S. contributions to HL-LHC (in words)

- At this time (pre-CD-1) the following deliverables are entertained for the US contribution to HL-LHC:
  - From the approve Preliminary Project Execution Plan

Parameters	Threshold Performance	Objective Performance
Inner Triplet Focusing Quadrupoles (Q1 and Q3)	a) 5 Q1-Cryoassemblies and 4 Q3-Cryoassemblies are accepted by CERN after testing at HL-LHC nominal temperature and ultimate gradient for the magnets, and functionality for the Cryoassembly. The Cryoassemblies will be assembled from Cold Masses built by HL-LHC AUP and Cryostat kits and tools provided by CERN.  b) Procurement of components for 1 additional Q3 Cold Mass	1 additional Q3-Cryoassembly is accepted by CERN after testing at HL-LHC nominal temperature and ultimate gradient for the magnets, and functionality for the Cryoassembly. The Cryoassembly will be assembled from Cold Masses built by HL-LHC AUP and Cryostat kits and tools provided by CERN
SRF Crab Cavities	a) 8 Radio Frequency Dipoles (RFDs) Dressed cavities for the HL-LHC Crab Cavity System are accepted by CERN after being tested at HL-LHC nominal temperature, nominal frequency, and ultimate cavity voltage. Dressed cavities include HOM couplers, pick-ups, He Vessel and magnetic shields.  b) Procurement of components for 2 additional RFD Dressed Cavities	2 additional Radio Frequency Dipoles (RFDs) Dressed cavities for the HL-LHC Crab Cavity System are accepted by CERN after being tested at HL-LHC nominal temperature, nominal frequency, and ultimate cavity voltage. Dressed cavities include HOM couplers, pick-ups, He Vessel and magnetic shields.

Approximately 50% of the Q1/Q2a & b/Q3 Final Focusing Triplets of HL-LHC

50% of the total number of Crab Cavities for HL-LHC

*CERN is also suggesting financial contribution to cavities built in Europe or e-lens contributions (“Up-scope” Opportunities)*

- Delivery Date Needs (from CERN):
  - Q1/Q3 Cryoassembly #1 at CERN by Late '21  
Cryoassembly #8 at CERN by Summer '24
  - RFD Dressed Cavity #1 at CERN by Late '22  
Dressed Cavity #8 at CERN by Summer-Fall '23



# Good News from CD-1 ESAAB !

- At ESAAB, the approved CD-1 Funding Profile reflect what was requested at CD-1 IPR Review *with increased funding* in FY20.

	FY16	FY17	FY18	FY19	FY20	FY21	FY22	FY23	FY24	FY25	Total
<b>PPEP</b>	0.1	0.5	27.0	42.0	50.0	42.0	33.0	21.0	12.0	0	227.6
<b>CD-1 Estimate</b>	0.0	0.4	26.6	42.2	43.9	47.2	33.4	20.7	11.3	1.7	227.5
<b>Difference</b>	0.1	0.1	0.4	-0.2	6.1	-5.2	-0.4	0.3	0.7	-1.7	0.1

- There is funding space in FY20 to advance procurements and speed up production, subject to the following constraints:
  - Keep FY19 cost the same
  - Keep cable to coil free float the same (~ 3 months)

# MOUs and FY18 SOWs

- What are they:
  - MOUs: Govern agreements between collaborating Laboratories and the Project.
  - SOWs: document the work to be accomplished at contributing institutions . Annual statements of work between Fermilab and the contributing institutions as well as frequent milestones are used to track progress of the contributions.
- MOU and SOW with LBNL fully signed and approved.
- SOW with BNL preliminarily signed. MOU with BNL still under BNL Directorate scrutiny.

US HL-LHC AUP

**FNAL – LBNL MOU on HL-LHC AUP**

US-HILumi-doc-752  
Other:  
Date: Sep. 29<sup>th</sup> 2017  
Page 5 of 15



**US HL-LHC Accelerator Upgrade Project**

**Memorandum of Understanding between Fermi National Accelerator Laboratory and Lawrence Berkeley National Laboratory on HL-LHC AUP**

Prepared by:  
Giorgio Apollinari: HL-LHC AUP Project Manager

Reviewed by:  
Giorgio Apollinari: HL-LHC AUP Project Manager  
Ruben Carcagno: HL-LHC AUP Deputy Project Manager

Approved by:  
Nigel Lockyer: FNAL Director  
Michael Withereff: LBNL Director  
Michael Lindgren: FNAL Chief Project Officer  
James Symons: LBNL Associate Laboratory Director  
Wim Leemans: LBNL ATAP Division Director  
Giorgio Apollinari: HL-LHC AUP Project Manager  
Ruben Carcagno: HL-LHC AUP Deputy Project Manager  
Soren Prestemon: HL-LHC AUP Laboratory Representative at LBNL

This document is uncontrolled when printed. The current version is maintained on <http://ila-hl-lhc.fnal.gov>

US HL-LHC AUP

**FNAL – LBNL MOU on HL-LHC AUP**

US-HILumi-doc-752  
Other:  
Date: Sep. 29<sup>th</sup> 2017  
Page 3 of 15

**APPROVALS AND SIGNATURES**

*Nigel Lockyer* Date: *10/11/17*  
Nigel Lockyer FNAL Director

*Michael Withereff* Date: *10/11/17*  
Michael Withereff LBNL Director

*Michael Lindgren* Date: *10/15/2017*  
Michael Lindgren FNAL Chief Project Officer

*James Symons* Date: *10/15/17*  
James Symons LBNL, Associate Laboratory Director

*Giorgio Apollinari* Date: *10/5/17*  
Giorgio Apollinari HL-LHC AUP Project Manager

*Wim Leemans* Date: *10/13/17*  
Wim Leemans LBNL, ATAP Division Director

*Ruben Carcagno* Date: *10/5/17*  
Ruben Carcagno HL-LHC AUP Deputy Project Manager

*Soren Prestemon* Date: *10/10/17*  
Soren Prestemon LBNL, HL-LHC AUP Laboratory Representative

This document is uncontrolled when printed. The current version is maintained on <http://ila-hlumi-docs.fnal.gov>

US HL-LHC AUP

**HL-LHC AUP FY18 Statement of Work with LBNL**

US-HILumi-doc-734  
Other:  
Date: Oct 2<sup>nd</sup> 2017  
Page 1 of 9



**US HL-LHC Accelerator Upgrade Project**

**FY18 Statement of Work with Lawrence Berkeley National Laboratory**

Prepared by:  
Giorgio Apollinari: HL-LHC AUP Project Manager

Reviewed by:  
Giorgio Apollinari: HL-LHC AUP Project Manager  
Ruben Carcagno: HL-LHC AUP Deputy Project Manager

Approved by:  
(approval records are kept in us-hilumi-docs.fnal.gov)  
Michael Lindgren: FNAL Chief Project Officer  
Giorgio Apollinari: HL-LHC AUP Project Manager  
Ruben Carcagno: HL-LHC AUP Deputy Project Manager  
Wim Leemans: LBNL, ATAP Division Director  
Soren Prestemon: LBNL, HL-LHC AUP Laboratory Representative

This document is uncontrolled when printed. The current version is maintained on <http://ila-hlumi-docs.fnal.gov>

US HL-LHC AUP

**HL-LHC AUP FY18 Statement of Work with LBNL**

US-HILumi-doc-734  
Other:  
Date: Oct 2<sup>nd</sup>, 2017  
Page 6 of 9

- WBS 302.03: Fabricate Unit Lengths (ULs) of insulated cable. Specifically, for FY18:
  - Fabricate 12 Cables UL (001 to 012)
  - Initiate Fabrication of 13<sup>th</sup> Cable UL (013)
  - Ship completed and accepted cables to FNAL and BNL as instructed
- WBS 302.07: Fabricate Structures and Assemble Magnets. Specifically, for FY18:
  - Re-assemble magnet prototype MQXFA-2b.
  - Ship to BNL MQXFA-2b for Testing
  - Conduct procurement of Structures for magnets MQXFA2 and MQXFA3.

**3 Cost**  
The following funding will be authorized for disbursement from DOE Headquarters at LBNL in FY18 to perform the activities listed in Section3 above:

WBS 302.1	221 k\$
WBS 302.01	842 k\$
WBS 302.03	659 k\$
WBS 302.07	2,940 k\$
<b>Total</b>	<b>4,662 k\$</b>

Additional funding disbursed to LBNL for HL-LHC AUP purposes is considered part of the Project Estimate Uncertainty Contingency and can be spent only after formal approval obtained according to the procedures described in the HL-LHC AUP Project Execution Plan.

**4 Deliverables and Milestones**  
The following list of Deliverables and Milestones apply to the HL-LHC AUP activities planned at LBNL in FY18:

- WBS 302.1 Deliverables/Milestones
  - LBNL Project Control interface to FNAL HL-LHC AUP EVMS system completed 19-Jan-18
  - Monthly Reports delivered (starts Nov. 2018) By the 5<sup>th</sup> day of each month
- WBS 302.01 Deliverables/Milestones
  - LBNL CAM Training Completed 18-Dec-17
  - LBNL scope PDR/TDR Completed 18-Apr-18

This document is uncontrolled when printed. The current version is maintained on <http://ila-hlumi-docs.fnal.gov>

# HL-LHC AUP: Funding Profile at CD-1

- FY18 Funding: 27 M\$
  - Activities at FNAL: 13.8 M\$
  - Activities at BNL: 3.5 M\$
  - Activities at LBNL: 4.6 M\$
  - Contingency: 5.1 M\$
  - Monthly Funding Profile

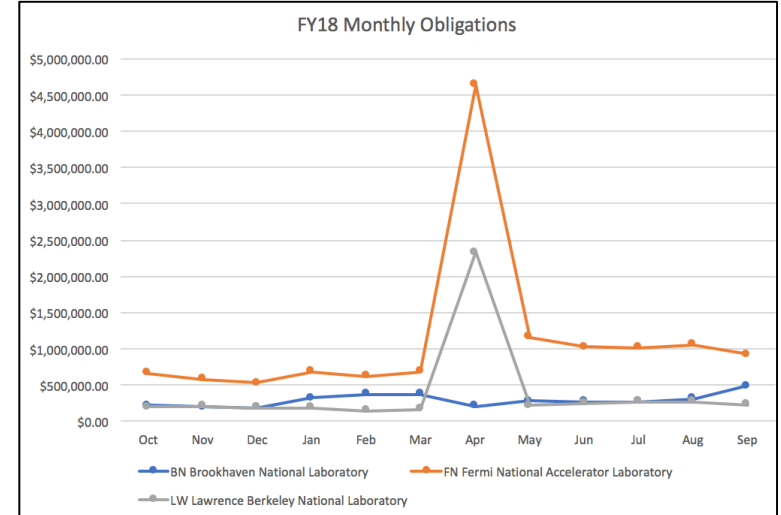

- All FY18 funding going toward potential “tunnelable” (i.e. Production) elements such as MQXFA03 coils
  - Every \$ spent from now onward is a not-recoverable \$ !

# Feedback from HL-LHC AUP CD-1 Review

## *Key Recommendations*

- Create and approve (structural and electrical) design criteria, including criteria for brittle materials, prior to CD-2/3b.
- Secure external review of these criteria prior to or during CD-2/3b.
- The project and CERN should work closely together to develop a viable project schedule with additional schedule contingency before CD-2.

## *Crab Cavities Recommendations*

6. Conduct an external full technical integrated system-level design review of RFD cavities and ancillary components before CD-2.

## *Cost & Schedule/Manaq. Recommendations*

9. Prior to CD-2, the U.S. HL-LHC management should work with CERN HL-LHC management to establish more concrete need-by dates for project deliverables that allow for a realistic amount of schedule contingency.
12. The project and CERN should work closely together to develop a viable project schedule with additional schedule contingency before CD-2.

# CD-1 Nomenclature & “CD-1Baseline”

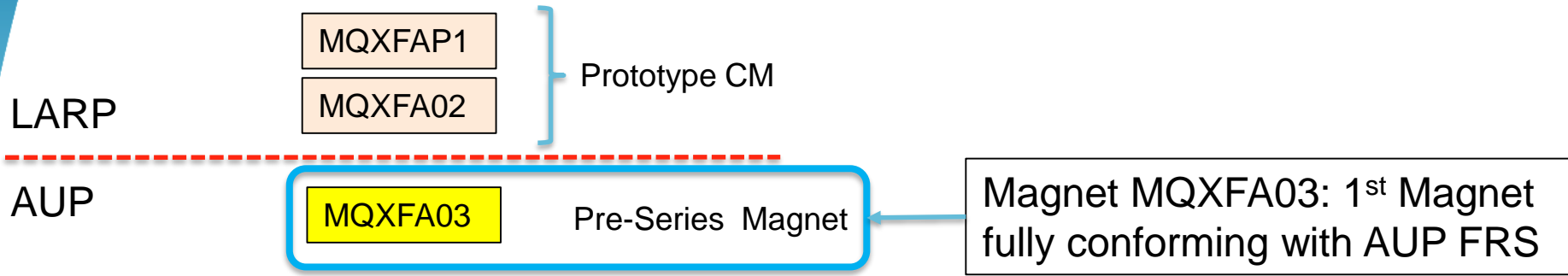

CD-3b (approval Magnet Prod.) - **June '18 (at the latest)**

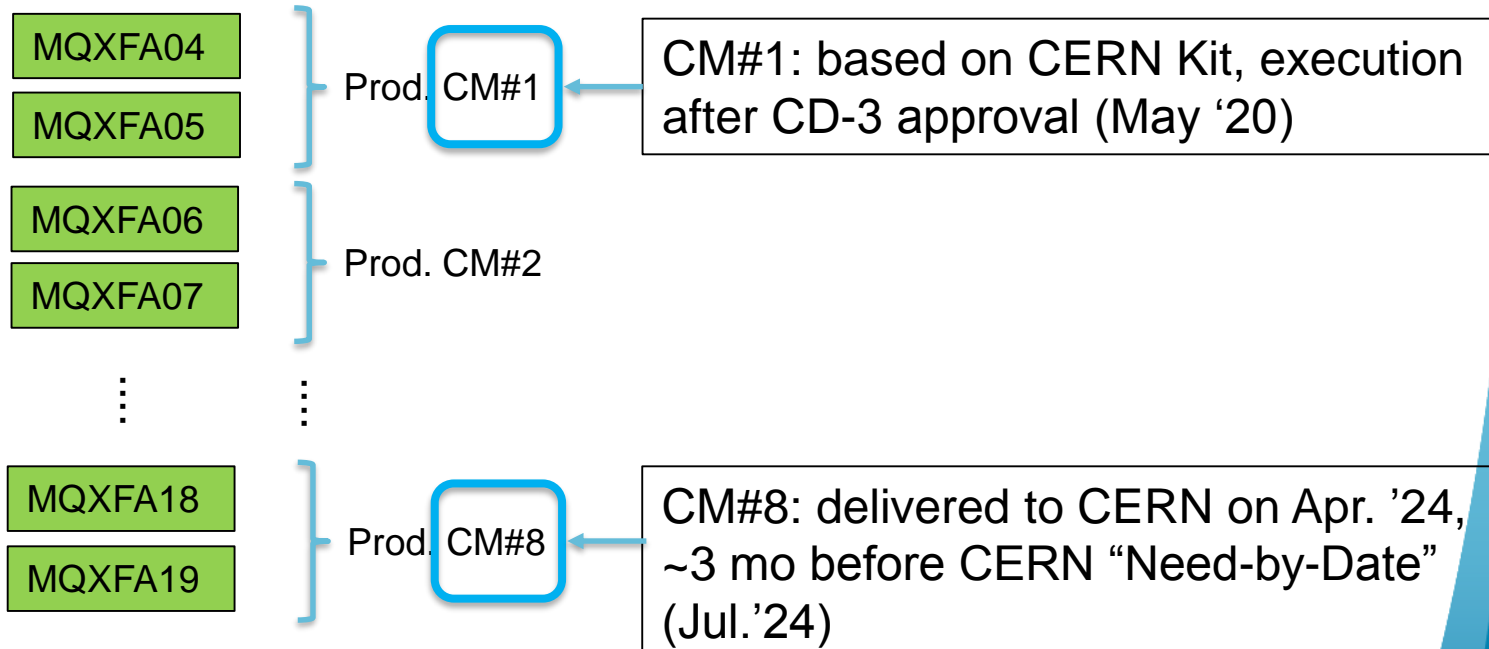

All “Prod.” are KPPs deliverables

# “CD-1 Baseline” (cont.)

- Extremely Compressed schedule for mandated reviews
- CD-3b Reviews (under US Responsibility):
  - Specific Magnets:
    - Design Criteria Jan '18 Called by Project, external rev. Team
    - Magnet FDR Jan '18 Called by Project, external rev. Team
  - Specific Cavities
    - Nb Material FDR Jan '18 Called by Project, external rev. Team
  - Overall Reviews
    - Director's Review Feb '18 Called by FNAL Director
    - DOE IPR Apr. '18 Called by DOE
- CD-2 would have to be postponed to ~FY20, with CD-3 (Start of Full Production)
  - Not enough time to include CERN Installation schedule

# Modified Nomenclature & “CD-1 Baseline”

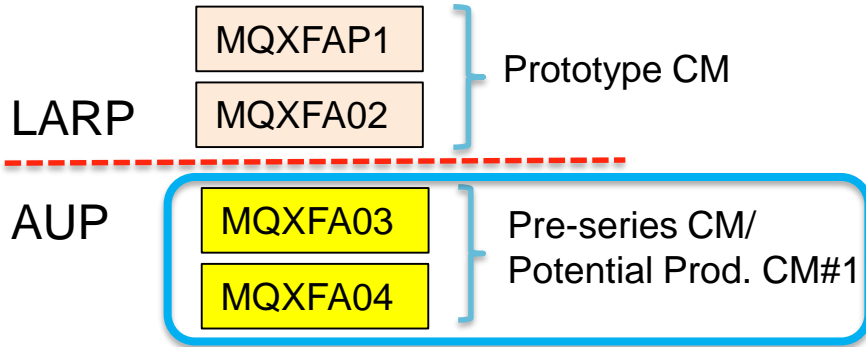

Both Magnet MQXFA03 and MQXFA04 are fully conforming with AUP FRS. They are assembled in “Pre-Series CM”

CD-3b (and CD-2) - February '19

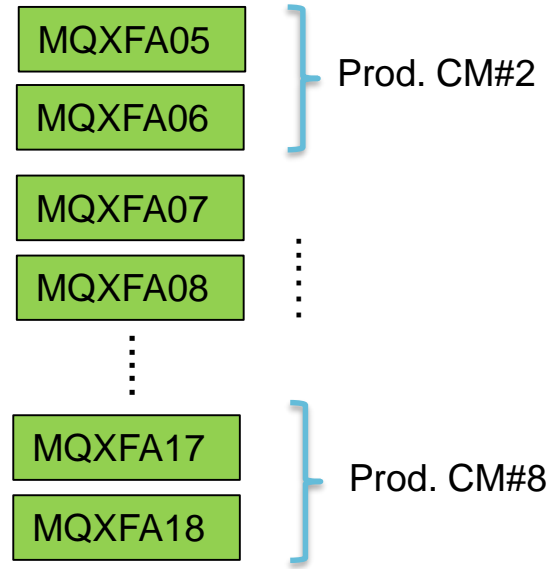

By maintaining same assembly rate, the opportunity offered by MQXFA03 can be capitalized in accelerating deliveries to CERN.  
*Usage of MQXFA03 increases schedule float by ~2mo*

*“Pre-Series CM” can be KPP deliverable upon certification of performance (gain ~2 mo. of float), otherwise MQXFA4 is recovered for future use. All “Prod.” are KPPs deliverables.*



# Modified Nomenclature “CD-1 Baseline” (cont.)

- CD-2/CD-3b Reviews (under US Responsibility):
  - Specific Magnets:
    - Design Criteria Apr '18 Called by Project, external review Team
    - Magnet FDR May '18 Called by Project, external review Team
    - Cold Mass/CA PDR Jun '18 Called by Project, external review Team
  - Specific Cavities
    - FDR for Nb Material May '18 Called by Project, external review Team
    - Sys. Int. Review Jun '18 Called by Project, external review Team
    - PDR for Cavities Jun '18 Called by Project, external review Team
  - Overall Reviews
    - Director's Review Aug-Sep '18 Called by FNAL Director
    - DOE IPR Oct-Nov. '18 Called by DOE
    - ESAAB Dec '18 or Jan '19
- CD-3 in FY20
  - Full approval for CryoAssemblies and RFD Production

# Project Close-End in a slide

An additional float of 2 months can be gained by reducing the duration of the winding step by 2 days starting October 2020 (40% into coil production). This change is expected to fit within the CD-1 funding table.

Expectation of additional float at CERN after completion of Installation Schedule (L. Rossi Verbal Communication at CD-1 Aug. Review )

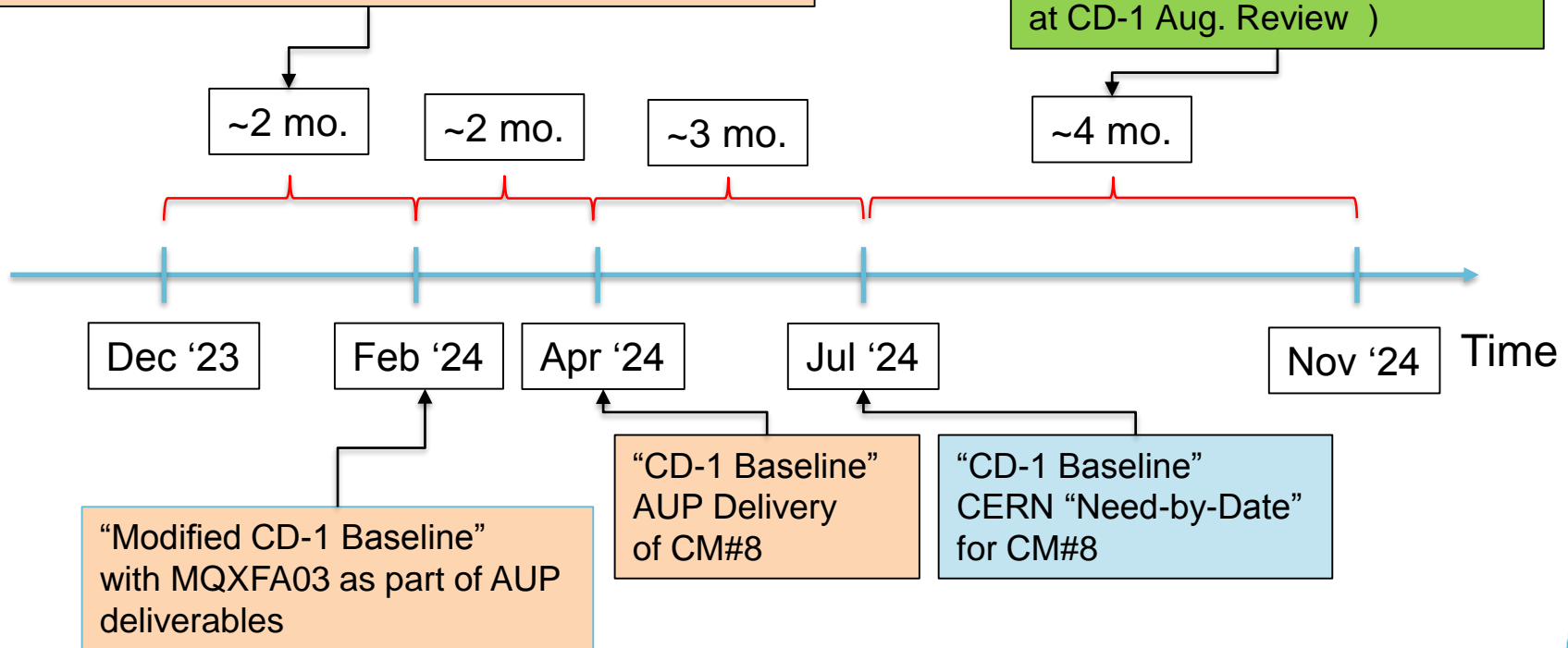

- Total expected schedule float before CERN "Need-by-date" of ~11 months.
  - Closer to the ~12-14 mos. we suspect we need to demonstrate to pass CD-2 without issues.

# “Post-CD-1 Review” Plan

- Proposal shown to DOE and endorsed in early November.
- Modified schedule provided to CERN on Nov 8<sup>th</sup> and used as basis for discussion at Madrid, and for preparation for future DOE CD-n Reviews.

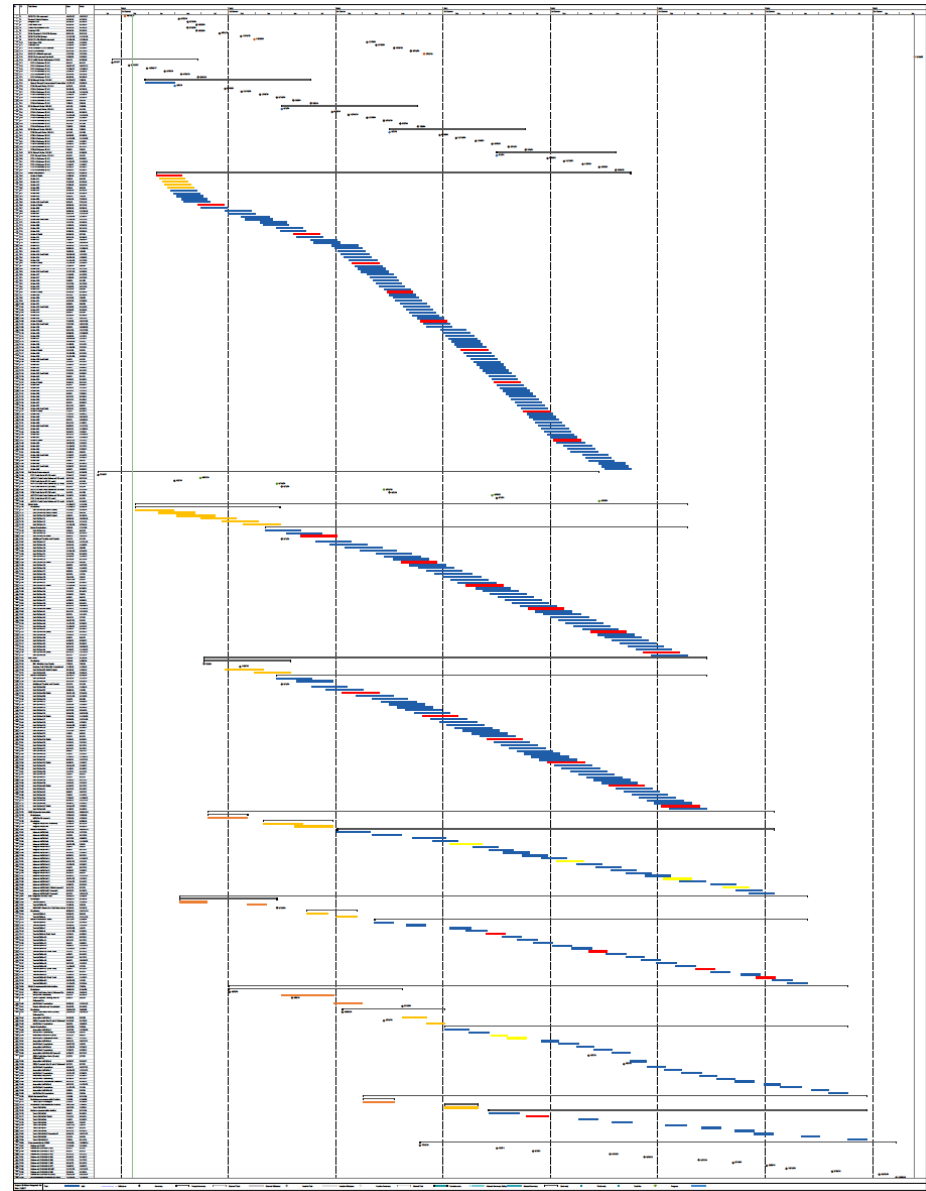

# CD-3a on Nb<sub>3</sub>Sn

- ESAAB/DOE also provided approval (CD-3a) for procurement of 9 metric tons (1,800 km) of Nb<sub>3</sub>Sn.
- Acquisition Plan for conductor available (US-HiLumi-doc-37, L. Cooley)
- Nb<sub>3</sub>Sn Acquisition fully integrated in AUP P6 Schedule
- Ready to proceed with Phased Procurement as soon as CR is over.

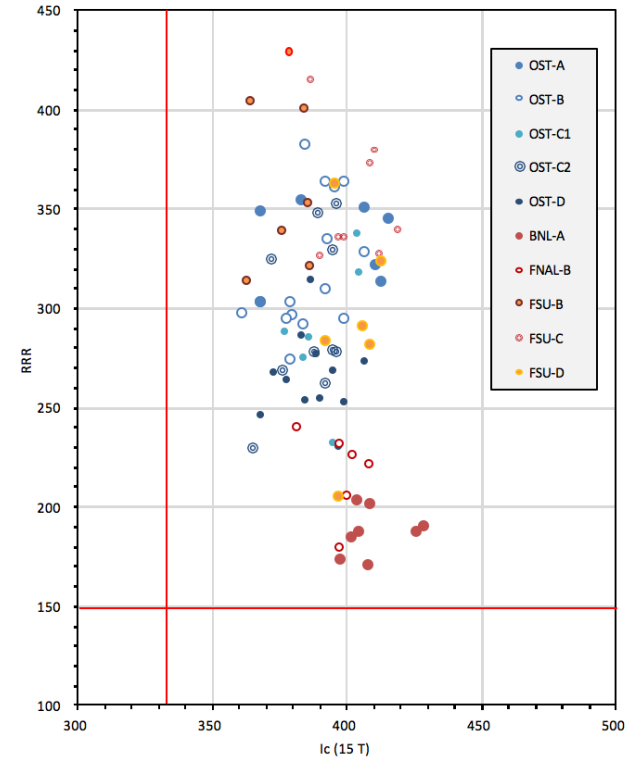

Activity Name	Start	Finish	FY2018				FY2019				FY2020				FY2021				FY2022					
			3	FQ4	FQ1	FQ2	FQ3	FQ4	FQ1	FQ2	FQ3	FQ4	FQ1	FQ2	FQ3	FQ4	FQ1	FQ2	FQ3	FQ4	FQ1	FQ2	FQ3	FQ4
<b>302-R-1 US HL-LHC ACCELERATOR UPGRADE</b>	Sep-01-17	May-10-22																						
<b>302-R-1.2 Q1/Q3 Cryo-assembly Fabrication</b>	Sep-01-17	May-10-22																						
<b>302-R-1.2.02 Strand Procurement</b>	Sep-01-17	May-10-22																						
<b>302-R-1.2.02.03 Strand Fabrication</b>	Sep-01-17	May-10-22																						
+ 302-R-1.2.02.03.01 LARP Strand Order (12 UL)	Sep-01-17	Jun-19-18	◆	◆	◆	◆	◆																	
+ 302-R-1.2.02.03.02 Strand Order (12 UL)	Apr-05-18	Jul-09-19						◆	◆	◆	◆	◆												
+ 302-R-1.2.02.03.03 Strand Order (29 UL)	Apr-01-19	Jul-06-20										◆	◆	◆	◆	◆								
+ 302-R-1.2.02.03.04 Strand Order (28 UL)	Apr-01-20	Jul-08-21													◆	◆	◆	◆	◆					
+ 302-R-1.2.02.03.05 Strand Order (21 UL)	Apr-01-21	May-10-22																		◆	◆	◆	◆	◆

# AUP Preparation for next CDs

- Planning to start process to obtain CD-2 and CD-3b in Spring 2018
- This will be a ~6 months long process (see slide #16).
  - CD-2 will require Preliminary Design Readiness
    - Preliminary design is complete when it provides sufficient information for development of the Performance Baseline in support of CD-2.
    - Quantifiable in ~50% - 70% drawings available
    - PDR needed for CM, CA and CC
  - CD-3b (Magnet Construction) will require Final Design Readiness
    - Quantifiable in more than 95% drawings available.
- Several elements will rely on CERN leadership, support or involvement in order to converge on CD-2/CD-3b for AUP

# Documentation Goals for 2018

- To be addressed at this Collaboration Meeting
- Functional Requirement Specifications
  - ✓ Magnets OK
  - Cold Mass To be Finalized. In CERN hands.
  - Requirements for CA Assembly Draft exist (AUP)
  - ✓ Crab Cavities OK
- Materials, Interfaces, Agreements and MIPs/MTFs Approvals
  - ✓ Materials for Q1/Q3 Magnets Assembly
  - **Critical** for Q1/Q3 Coil and Magnets MIPs/MTFs
  - *Timely* for Q1/Q3 Cold Mass (to include welding)
  - *Timely* for CC Nb Raw material
  - *Timely* Interfaces for Magnets
  - *Timely* for Pressure Vessel Safety Agreement
- Acceptance Criteria
  - *Timely* for Q1/Q3 Magnets Draft Exist (AUP)
  - *Timely* for Cold Mass Draft Exist (AUP)
  - Initial development for CryoAssembly
  - Initial development for Crab Cavities

**Critical:** Needed Yesterday !

*Timely:* Needed for CD-2/CD-3b Reviews (~Jun. 18)

*Initial:* Needed for CD-3 Review (~FY20)

# Material Approvals and MIPs

- Magnet Materials list shared with CERN/WP3 in early 2016.
  - Comments on Co-content of SS Materials
  - MQXF Magnets from AUP are expected to be amply below 0.1% Co-content request.
  - Thank You very much for EDMS Approval !
- ***MIPs (Manufacturing & Inspection Plans) & MTFs***
  - Submitted to CERN MIPs for MQXFA Cables and Coils
    - **Thanks for uploading Cables MIPs in EDMS !**
      - Eagerly awaiting their approval since MQXFA03 is a “tunnel-bound” magnet.
    - MIPs for Coil Manufacturing will require determination on Inner Quench Heater by late Nov. 2017
      - Upcoming decision: stop MQXFA03 Coil Production or continue with possibly NC Magnet by Dec. '17.
    - **Thanks for uploading Coils MIPs in EDMS !**
      - Eagerly awaiting their approval by ~Dec.'17 since MQXFA03 is a “tunnel-bound” magnet.
  - MIPs for MQXFA Structure Assembly to be submitted by ~Mar. '18
    - MQXFA Structure Assembly MIPs approval needed by Jun '18, in time for MQXFA03 Structure Assembly in later CY18 !

# Parts/Tooling Exchange

- Parts Exchange (EDMS 1825173)
  - (Proposed) Timeline of Exchange

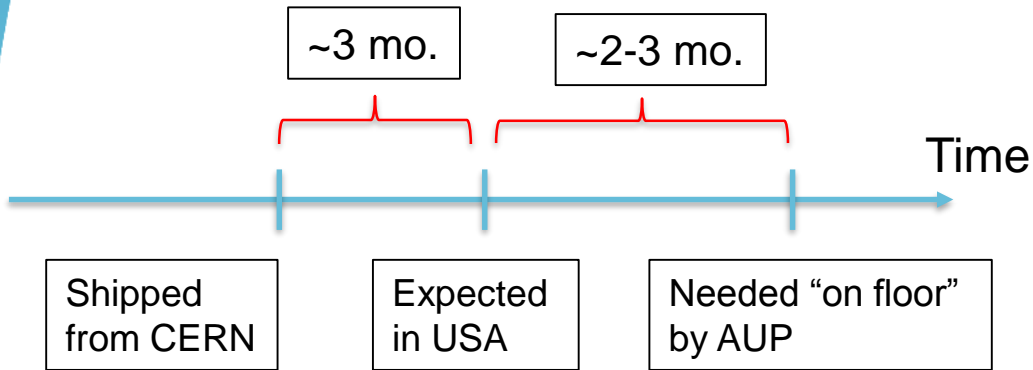

- Convergence expected in HiLumi-Madrid !
- Tooling
  - Tooling expected from CERN is CryoAssembly tooling designed & built as a carbon-copy of CERN design/procurement
  - Tentative agreement reached on Oct 10<sup>th</sup>, EDMS-1865080

EDMS NO. 1825173 | REV. 1.0 | VALIDITY DRAFT

### Parts exchange for HL-LHC AUP Q1&Q3

November 9, 2017

**Parts expected from CERN:**

**NbTi Cables and Traces:**

- Nb-Ti cables to be used for MQXFA leads: 1000 m (10 m per coil)
- Nb-Ti cable for LMQXFA bus-bars: 720 m (60 m of per Cold Mass plus one spare)
- Traces: 96 sets (set = Inner and outer layer trace)

Need by Date	Qt. of NbTi cable (m)	Qt. of Traces (#)
April, 2018	400	12
April, 2019	400	18
April, 2020	400	26
April, 2021	400	24
April, 2022	120	16

EDMS NO. 1825173 | REV. 1.0 | VALIDITY DRAFT

**Cold mass:**

- 2 End domes – a.k.a. end covers (per cold mass)
- 1 Cold bore tube (per cold mass)
- 2 Heat exchangers tube (per cold mass)
- 2 Temperature sensors (per cold mass)
- 12 mirrors to be installed on the SS shell for survey (per cold mass)
- 2 Low cobalt SS plates (per production cold mass - to be paid for by HL-LHC-AUP)

**Cryostat:**

- All parts including assembly tooling (US safety analysis to be performed by US engineer)

Need by Date	Cold Mass Parts
October, 2018	Prototype
October, 2019	5 sets
February, 2022	5 sets

Need by Date	Cryostat
May, 2019	Tooling and Prototype kit
March, 2020	5 kits
June, 2022	5 kits

**Cold Tests:**

- Heater Firing Units for Cryo-assembly test: 24 + 2 spares

**Need by date: March 2019**

# LQXFA/B Acceptance Criteria

- Document developed by Ruben, shared at Madrid with WP3/CERN.
- Based on FRS for Magnets and Cold Mass, and on (yet to be written) “Requirements for CA Assembly”.
- Designed around:
  - Verification Method
  - Procedure Summary
  - Reference(s)

	<b>Acceptance Plan for LQXFA/B</b>	US-HiLumi-doc-XX Other: Date: XX Page 8 of 21
<p><b>Requirement LMQXFA-R-T-01:</b> The LMQXFA assembly physical length (end cover to end cover, including tolerances) must be <math>\leq 10,100</math> mm. This dimension is at room temperature (296 K). <b>Verification Method:</b> Mechanical measurements after fabrication of each cold mass assembly <b>Procedure summary:</b> Laser Tracker survey <b>Reference:</b> Cold Mass Assembly Traveler [TBD]</p>		

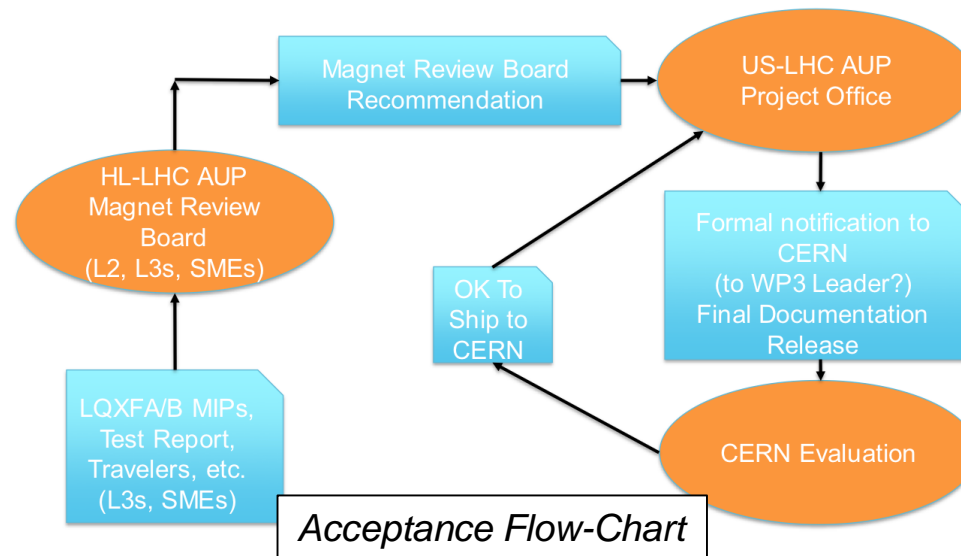

# Interfaces

- Interfaces definitions critical for design and start of production.
  - Magnet interfaces needs to be finalized by MQXFA Final Design Review for CD-3b (Summer '18)
    - Electrical Interfaces
    - Cryogenic Interfaces
    - Electrical Interfaces
    - Quench Protection Interfaces
  - Cold Mass, CryoAssembly and CC interfaces needed to achieve preliminary definition by Preliminary Design Review (Summer '18) and final definition by CD-3 (Summer 2020)
    - CryoAssembly
    - CC
- Magnet Interfaces Workshop (remote is fine) with CERN by April 9<sup>th</sup>-20<sup>th</sup>, 2018 ?
  - Maybe 2 workshops, on Mech./Cryo. and Elec./QP Interfaces ?
  - Is there a CERN formal Interface Control System?
  - Can we keep building on whatever it contains today for Magnet Interfaces ?
  - Approval path for Interfaces ?

# Pressure Vessel Safety

- First request sent to HiLumi Project office on June 2016.
  - Request to adopt FNAL Pressure Vessel Safety Code (ASME-based)
- Will be followed by Tom Page (AUP System Integration Engineer)
  - Functions documented in AUP PMP:
    - Mostly focused on coordinating activities across the entire Project focusing on preparing the standards and procedures required to manage and execute the Project in accordance to the lead laboratory Engineering Manual and in agreement with the requirements from the final customer.
- Interact with HiLumi Project Office (T. Otto) in order to obtain HSE exemption for Pressure Vessel equipment
  - *Timely* for He-Vessel Test on US Short Model Magnet
  - Convergence by Spring '18 (or earlier) ?



# FY17 AUP Technical Achievements

- Successfully completed assembly of first long HL-LHC quad: MQXFA1P. 4m long coils in 4.2m long Structure
- Magnet at BNL for testing since late July '17.
  - First quench in Aug '17 at 15,475 kA.
  - LARP Team had to address and solve several problems since then: strain gauges signals, burst disk breakage, He contamination, QP signal delays, o-ring in cryo expansion engines.
  - End of this “extenuating wait” eagerly awaited !
- Started coils for MQXFA03, first potentially tunnel-bound magnet !
- Successfully completed and measured all LARP NW cavities at JLAB.
  - All Cavities exceeding HL-LHC performance requirements
- Successfully tested at FNAL one RFD, confirming JLAB measurement and identified quench location with 2<sup>nd</sup> sound technology

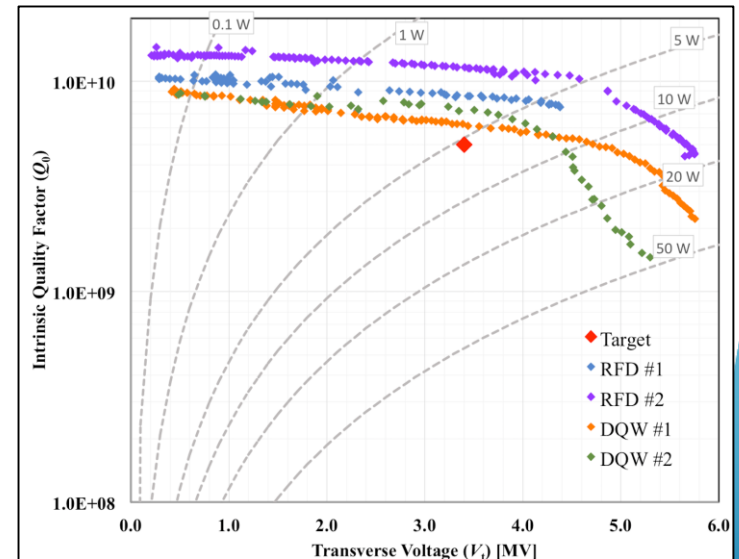
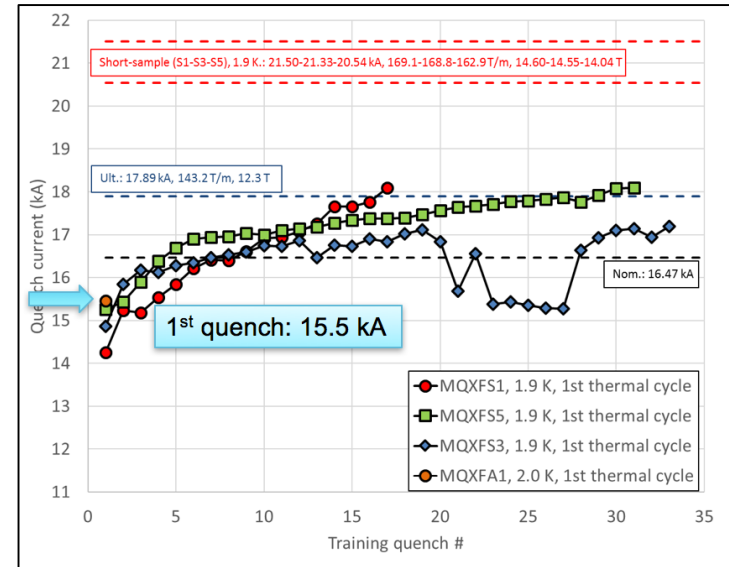

# Cavity Insertion in VTS #3

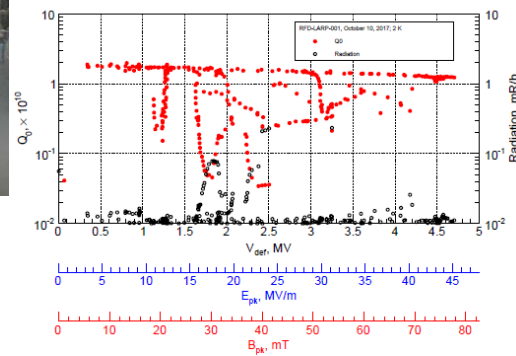

# FY18 AUP “Technical” Goals

- Complete Test of MQXFAP1
  - Quench campaign should have been completed by September. Good hopes for end-November.
- Complete Assembly of MQXFA02 and first test
  - Focus on FQ, Alignment
- Continue production of MQXFA03,... coils
- Place Nb<sub>3</sub>Sn Procurement
- Rotating BCP Tool developed (ANL) and tested on NW RFD cavity
- Place order for RFD Prototypes

# LARP

- As expected from the P5 report in the US, LARP effort is strongly re-dimensioned after start-up of HL-LHC AUP
- FY18 LARP funding has been directed by DOE to support handshaking on MQXFA magnets in LARP (MQXFAP1 and MAQXFA02) and AUP (MQXFA03 onward).
  - No LARP funding in FY18 (and, likely, beyond) for CC, e-lens, Acc. Physics, etc.
  - Support of Toohig Fellowship is expected.

	FY14	FY15	FY16	FY17	FY18
e-lens	150	150	340	500	~300
Acc. Systems	592	150	149	130	0
Quad. Magnets	7,854	10,500	11,428	13,157	~4,700
Management	1,485	1,375	1,445	1,635	0
Crab Cavities	1,136	1,200	1,458	2,137	0
WBFS	1,183	625	560	300*	0
Reserve				641	0
<i>Total</i>	<i>12,400</i>	<i>14,000</i>	<i>15,380</i>	<i>18,500</i>	<i>5,000</i>

# Toohig Fellowship

- Extremely successful Fellowship program – Toohig Fellowship - with several young Accelerator Scientist providing vital contributions to the LHC and field in general

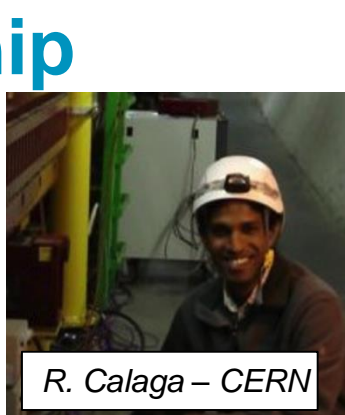

R. Calaga – CERN



H. Felice – CEA

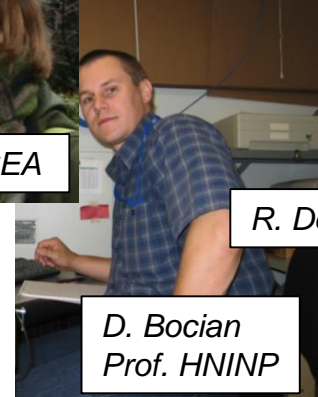

D. Bocian  
Prof. HNINP



R. DeMaria – CERN

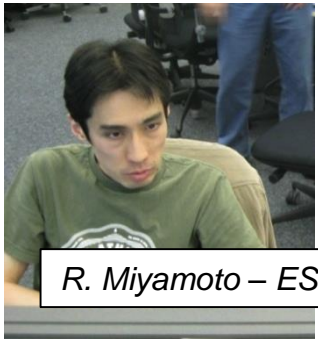

R. Miyamoto – ESS



T. Mastoridis  
Prof. CPU



V. Previtali  
Teacher, Geneva



S. White – ESRF



J. Cesaratto  
Phillips

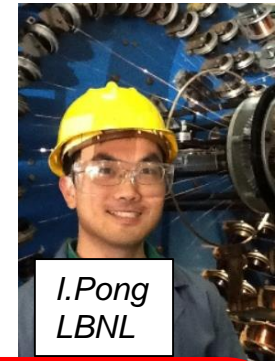

I. Pong  
LBNL



S. Verdu  
BNL

logo  
area



T. Holik  
FNAL



E. Ravaoli  
LBL



M. Fitterer  
FNAL



V. Marinozzi  
FNAL



# Conclusions



- Support from DOE and CERN for CD-1/CD-3a process highly appreciated.
- Good team effort to achieved CD-1/CD-3a in FY17.
  - Next goal is to fully develop the new plan and aim for CD-2/CD-3b in late CY18.
- Coil and Magnet production continues with good progress
  - Delay in MQXFAP1 vertical magnet testing should be over. Need to complete MQXFAP1 since MQXFA02 is coming soon !
- LARP CC effort brought to a soft, successful landing.
  - RFD team organizing for pre-series cavities in AUP.

