



Updates on the thermo-mechanical calculations on the LHC TDE

Tobias Polzin
EN-STI-TCD



7th HL-LHC Collaboration Meeting – 14th November 2017

Agenda

- The LHC and the TDE
- New Beams and new Demands
- Outlook

The LHC and the TDE - Overview -

The whole section is filled with N_2
to avoid oxidation

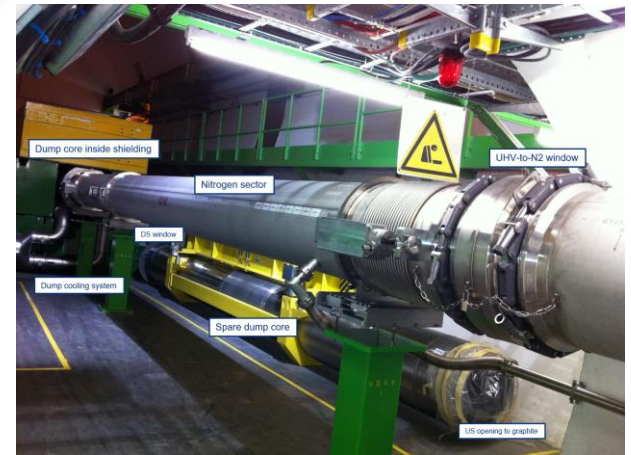
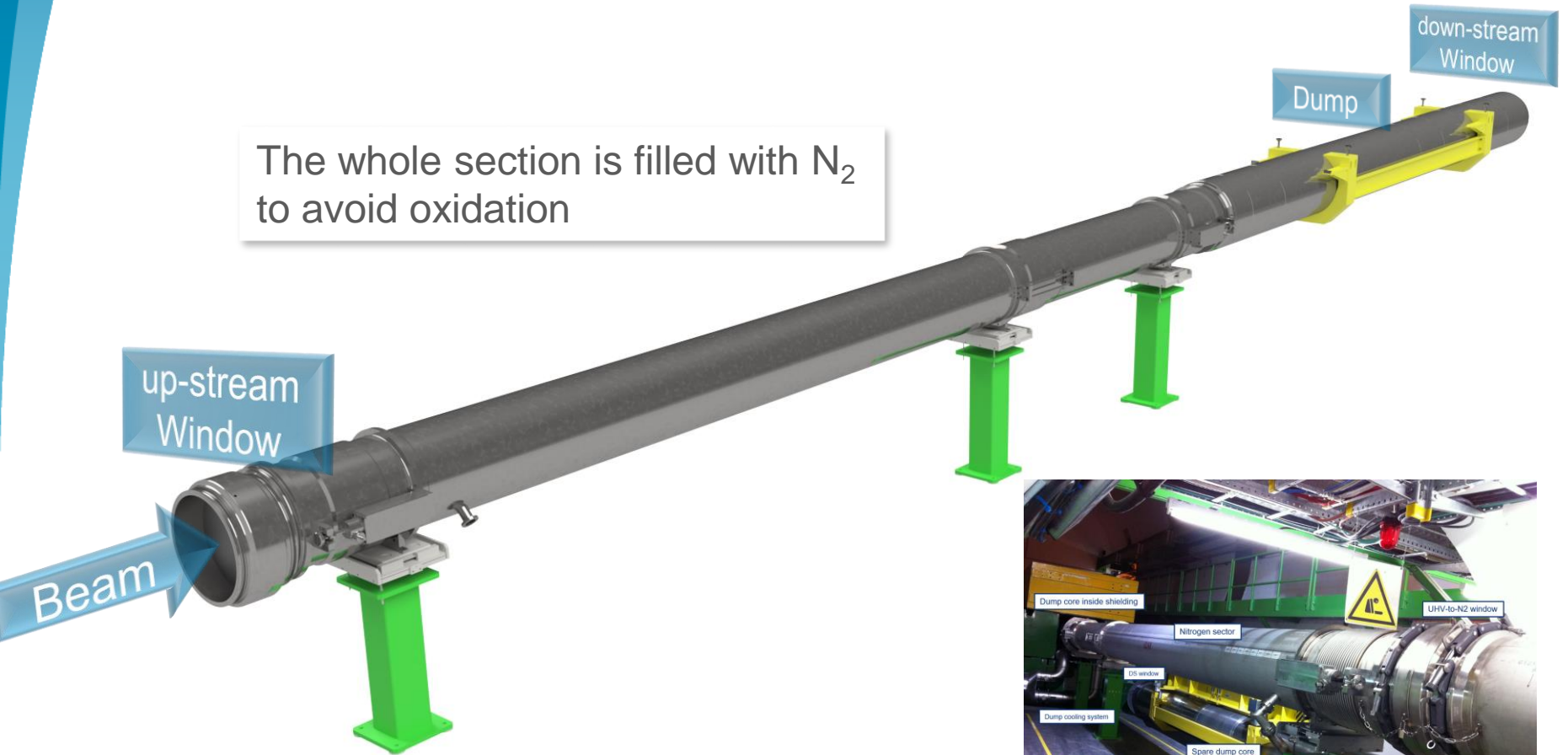

The LHC and the TDE - The Up-Stream Window -

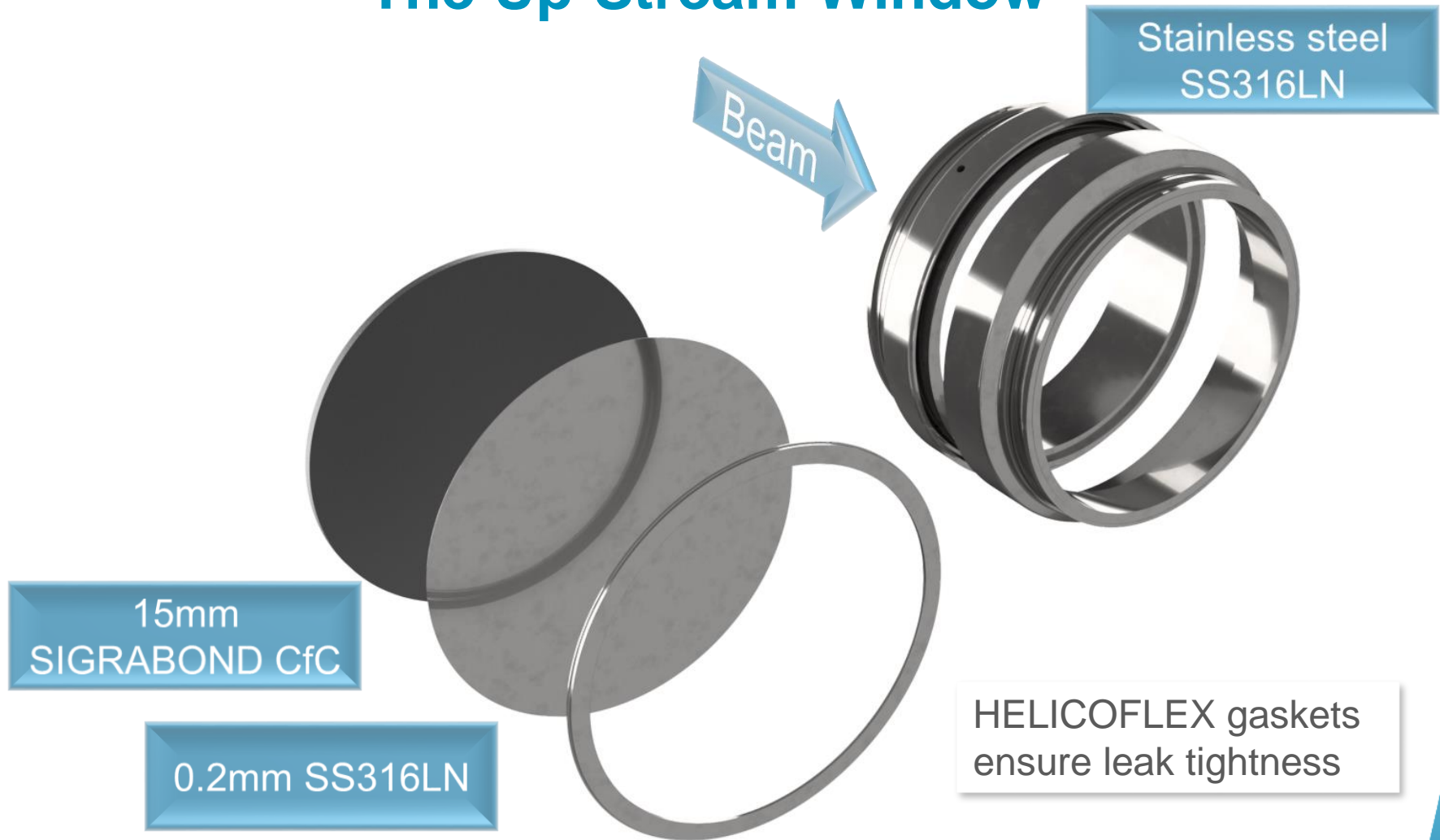

Source:

<https://edms.cern.ch/document/1867550/1>

The LHC and the TDE

- The Up-Stream Window -

- CFC takes load of pressure difference
- steel foil separates the nitrogen atmosphere from the machine vacuum
- Steel foil suffers more than the CfC under the beam
- Small **beam emittance** dominates stress generation

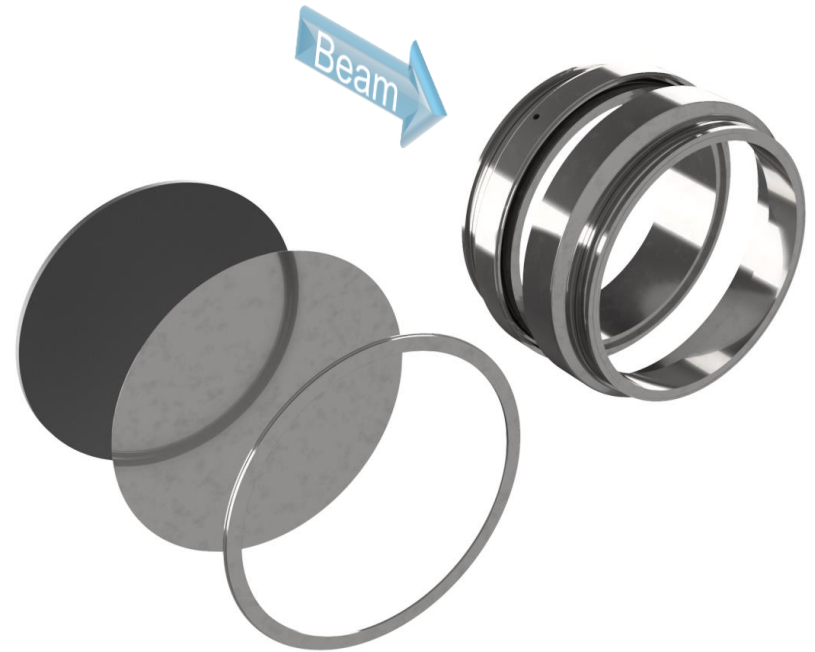

The LHC and the TDE - The Core -

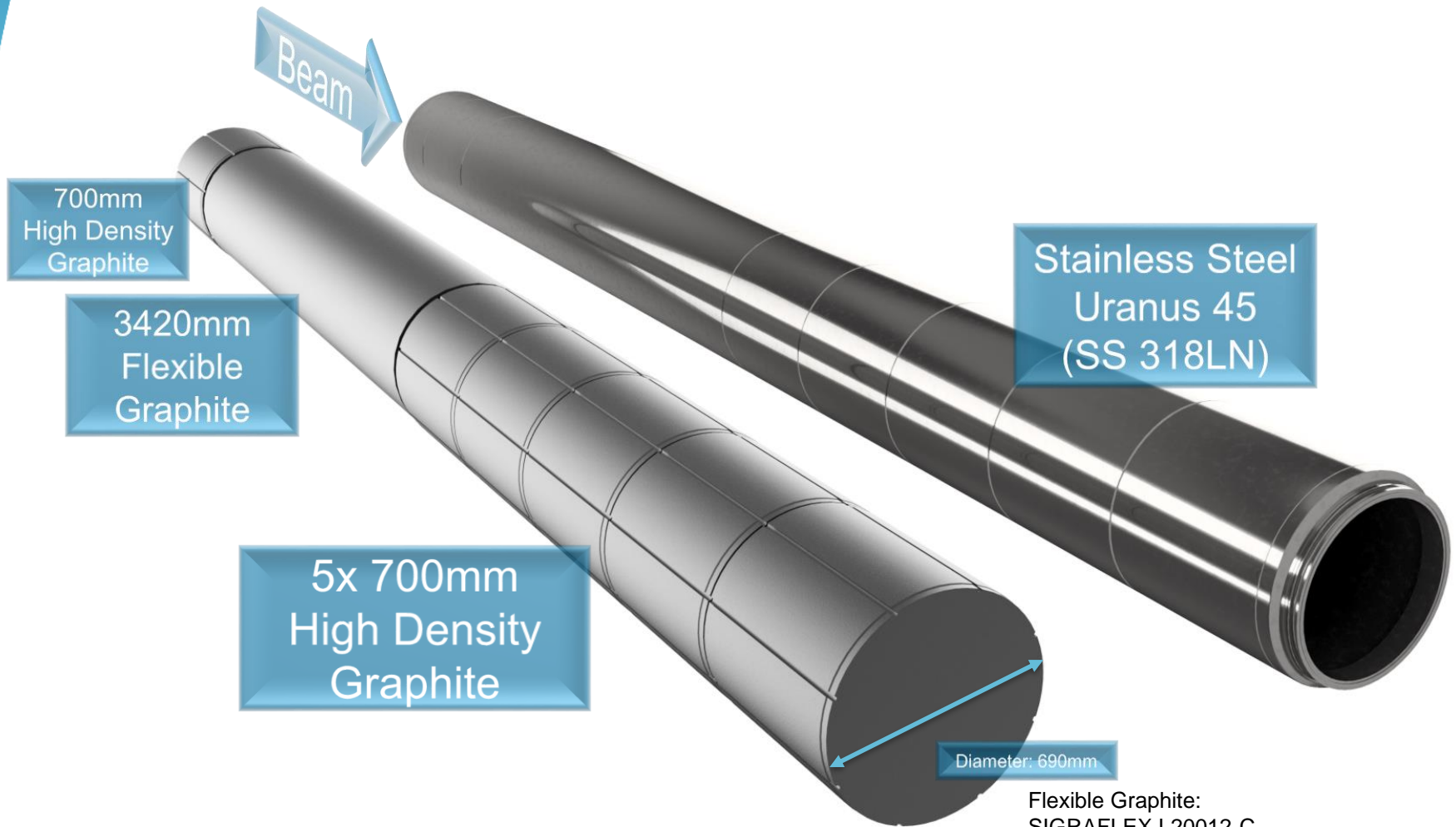

Flexible Graphite:
SIGRAFLEX L20012-C
High Density Graphite:
SIGRAFINE R7300 P500, shrink fitted
Source:

<https://edms.cern.ch/document/1867550/1>

Tobias Polzin - EN-STI-TCD

The LHC and the TDE

- The Core -

- Dump core absorbs the majority of the energy of the beam about 300 MJ in Run2
- Peak temperature is in the low density, flexible Graphite with 1050°C for Run2

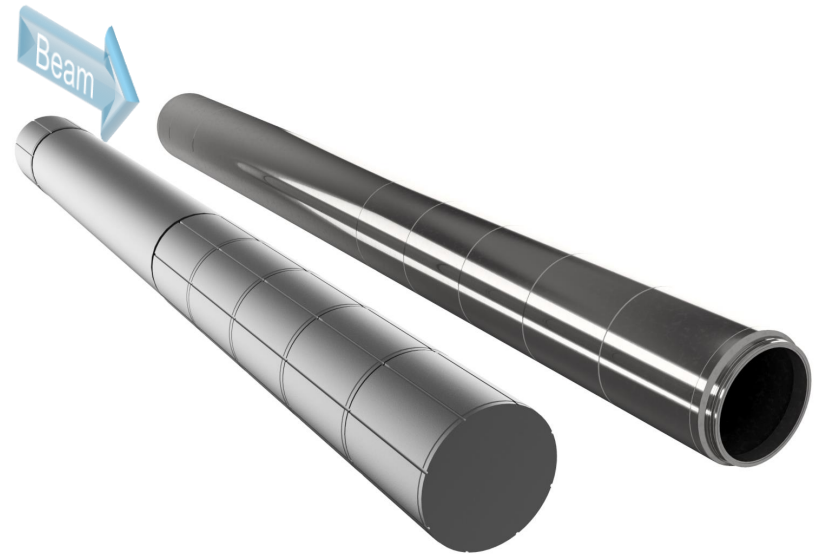

The LHC and the TDE - The Down-Stream Window -

10mm Titanium
Grade 2

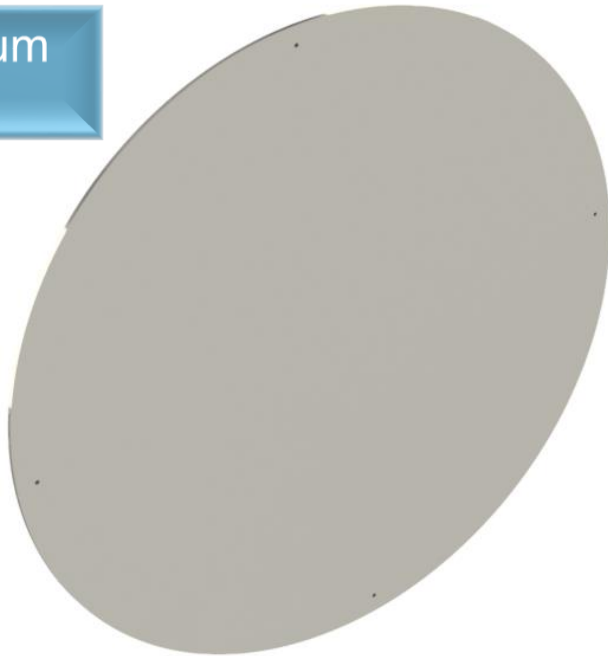

Stainless Steel
Uranus 45
(SS 318LN)

HELICOFLEX gasket
ensures leak tightness

Source:

<https://edms.cern.ch/document/1867550/1>

The LHC and the TDE

- The Down-Stream Window -

- Window keeps Nitrogen inside
- It separates the dump core from the **external** environment
- **Beam total intensity** dominates stress generation, due to showers caused by the dump core

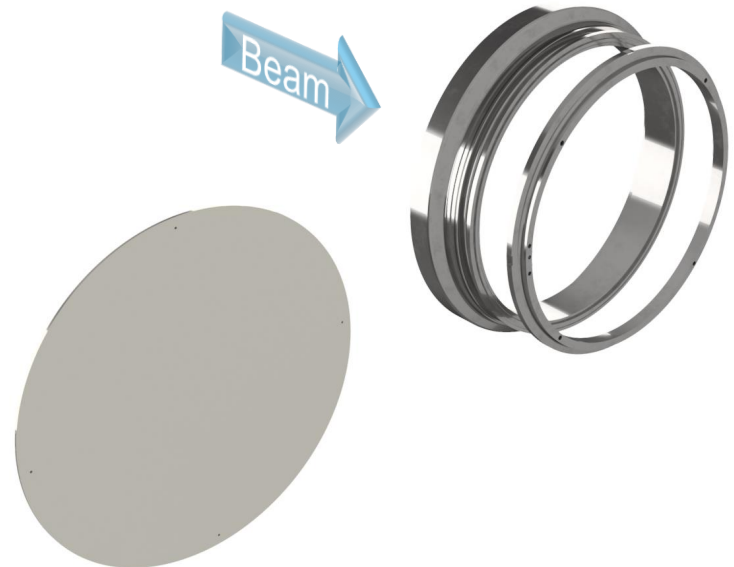

New Beams and New Demands

- Energy and Intensity over Time -

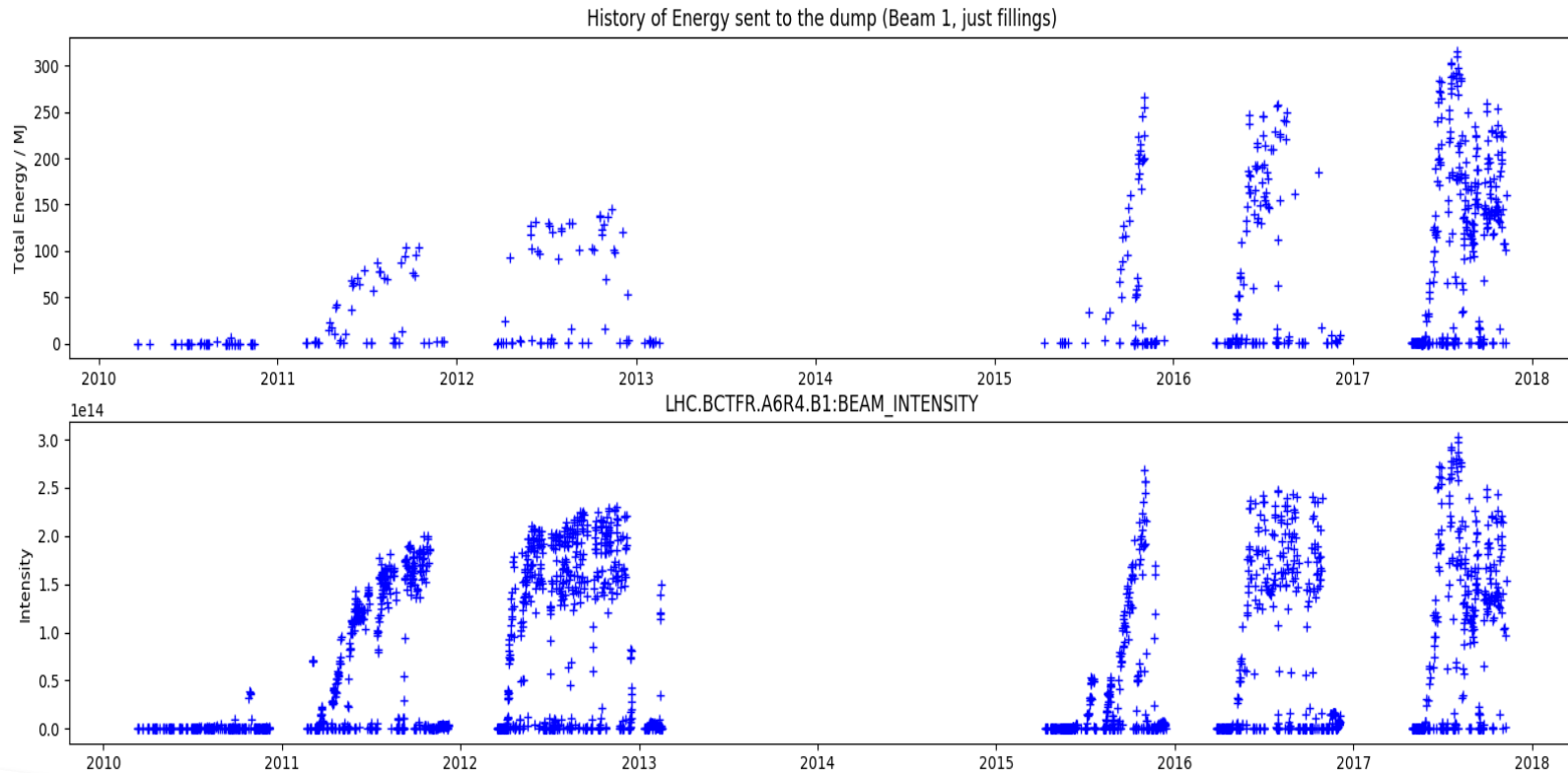

JUST AN ESTIMATION!

New Beams and New Demands

- Comparison of the Beams -

- Worst beam for up-stream window

	Run 2 (BCMS)	Hi-Lumi (BCMS)
Energy	7 TeV	7 TeV
Intensity	2604 x 1.3E11 p+	2604 x 2.0E11 p+
Emittance	1.37 μ mrad	1.37 μ mrad

- Worst beam for down-stream window

	Run 2 (standard 25ns)	Hi-Lumi (standard 25ns)
Energy	7 TeV	7 TeV
Intensity	2604 x 1.3E11 p+	2748 x 2.3E11 p+
Emittance	2.6 μ mrad	2.08 μ mrad

New Beams and New Demands

- Up-Stream Window Normal Operation Run 2

FrontWindow--R2-BCMS--6V4H
 Time = 0
 Contours of Effective Stress (v-m)
 max IP. value
 max=0, at elem# 1

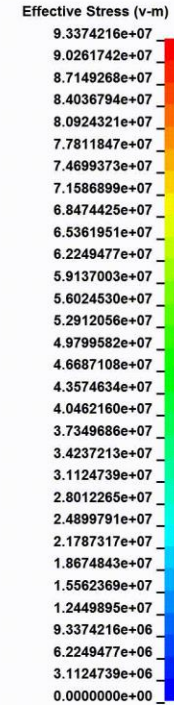
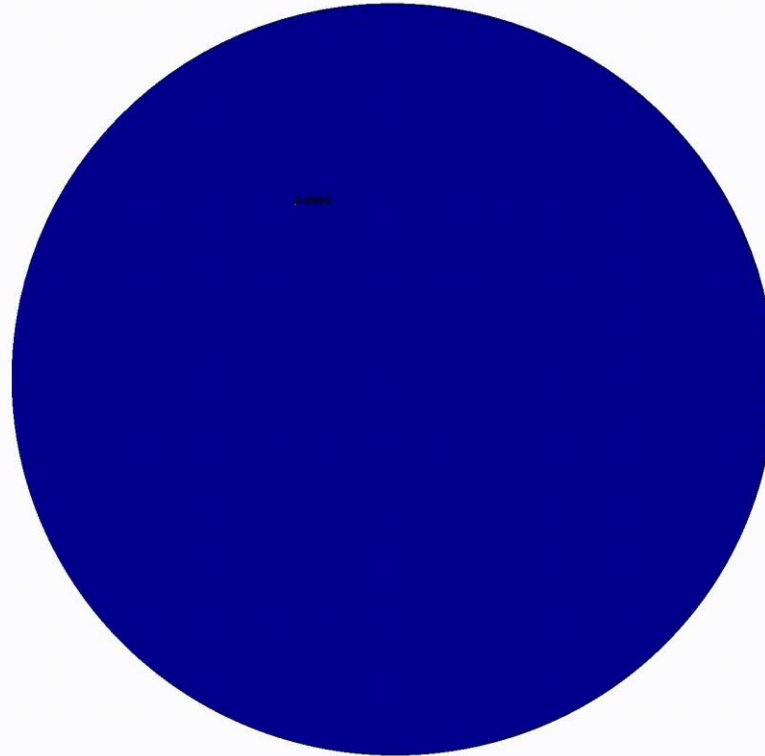

Maximum v. Mises stress	93.4 MPa
Temperature in the peak	45.7°C
Yield strength at 100°C	250 MPa
Safety factor against yielding	2.67

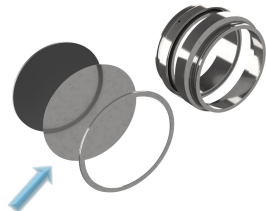

New Beams and New Demands

- Up-Stream Window Normal Operation HiLumi -

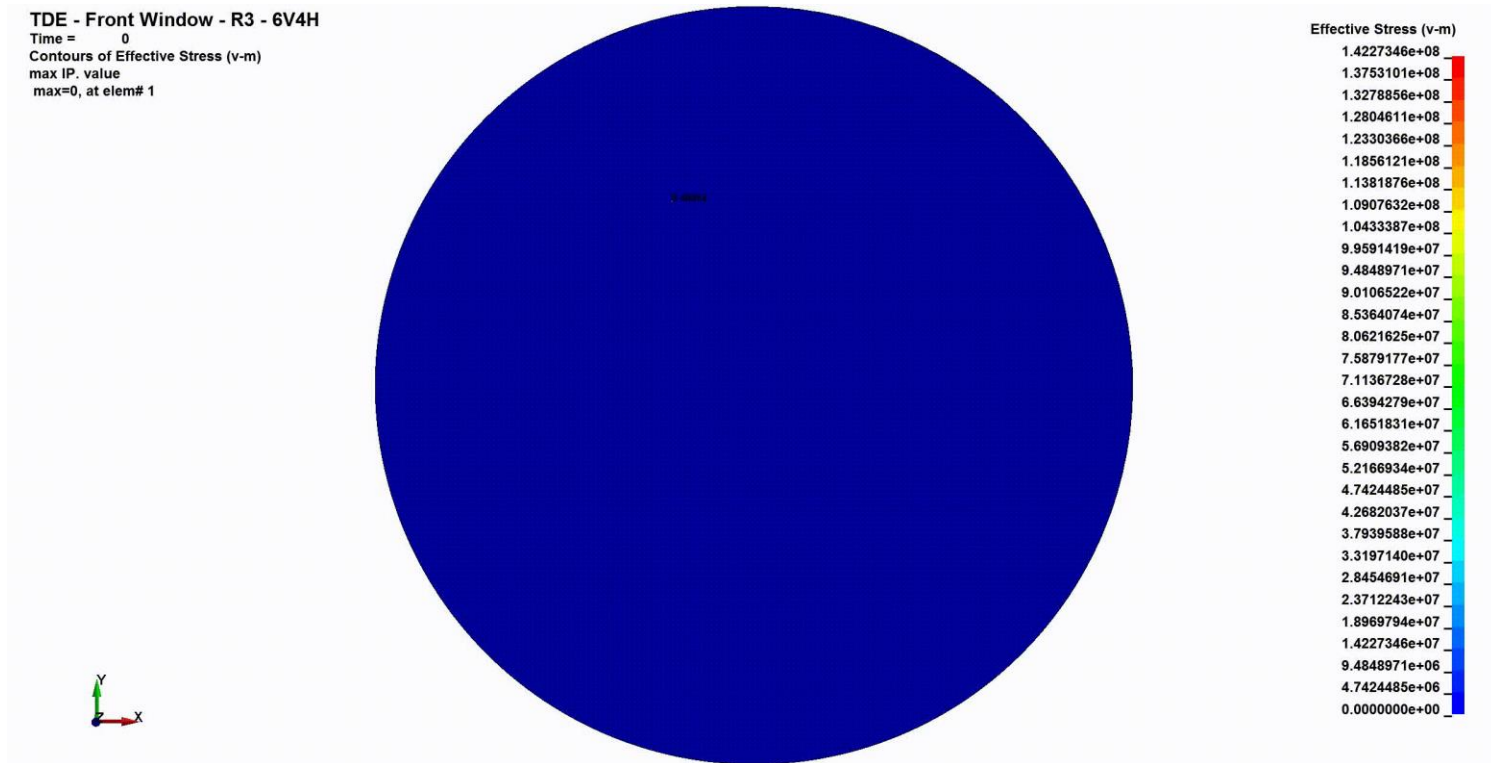

Maximum v. Mises stress	142.3 MPa
Temperature in the peak	57.7°C
Yield strength at 100°C	250 MPa
Safety factor against yielding	1.76

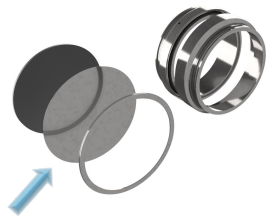

New Beams and New Demands

- Up-Stream Window Failure HiLumi 6V2H -

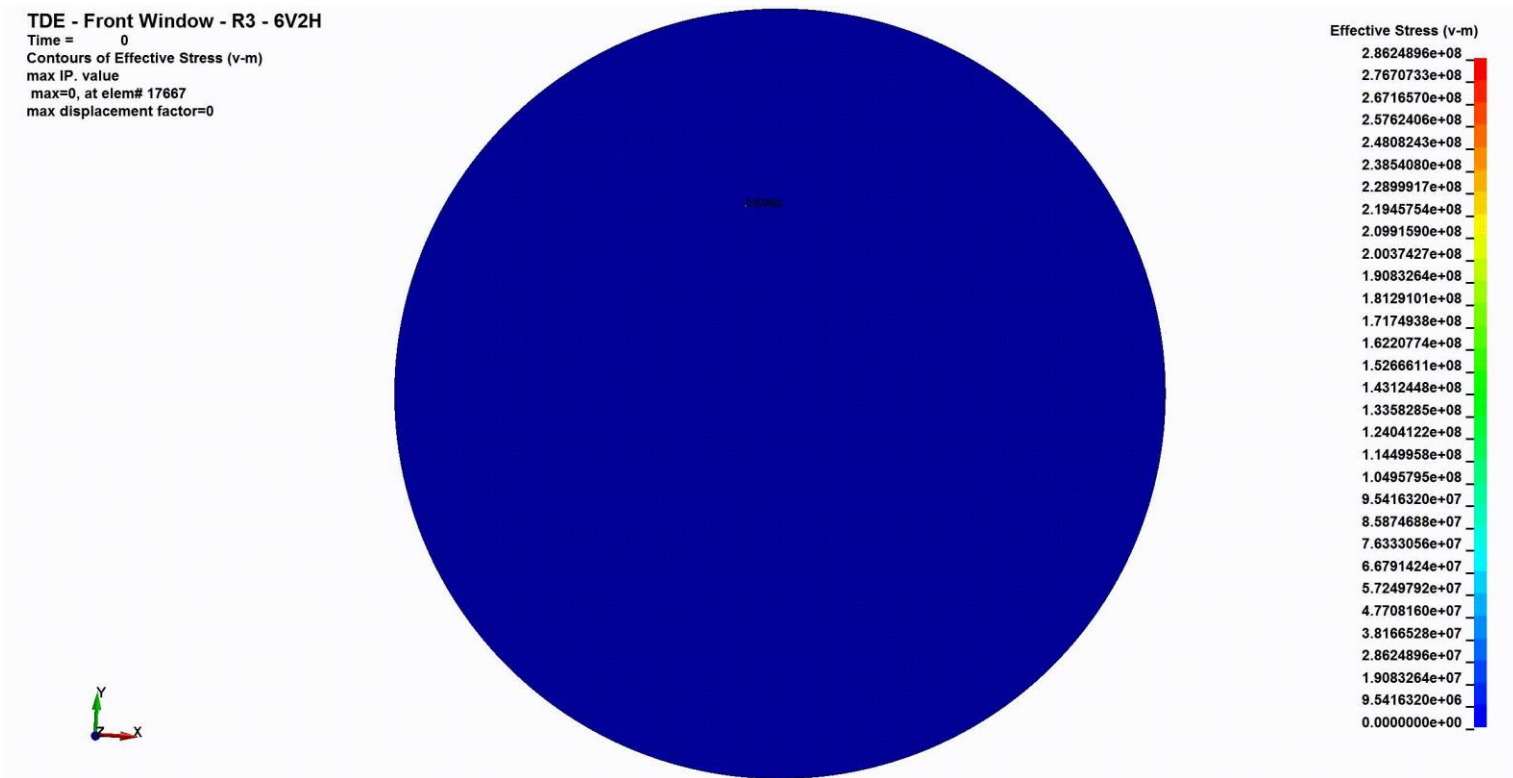

Maximum v. Mises stress	286.2 MPa
Temperature in the peak	85°C
Yield strength at 100°C	250 MPa
Safety factor against yielding	0.87

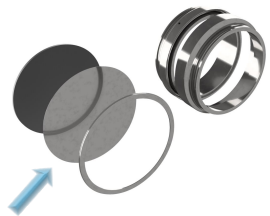

New Beams and New Demands

- Up-Stream Window HiLumi Retrigger -

TDE - Front Window - R3 - 6V4H with an horizontal delay of -14us
 Time = 0
 Contours of Effective Stress (v-m)
 max IP. value
 max=0, at elem# 1

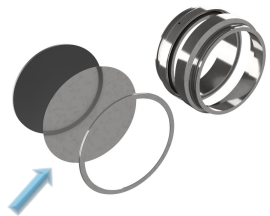
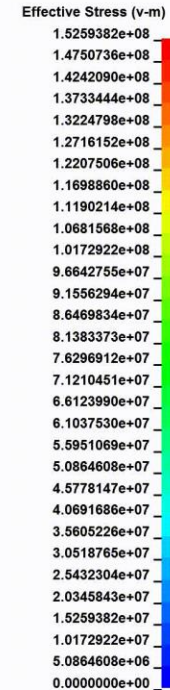
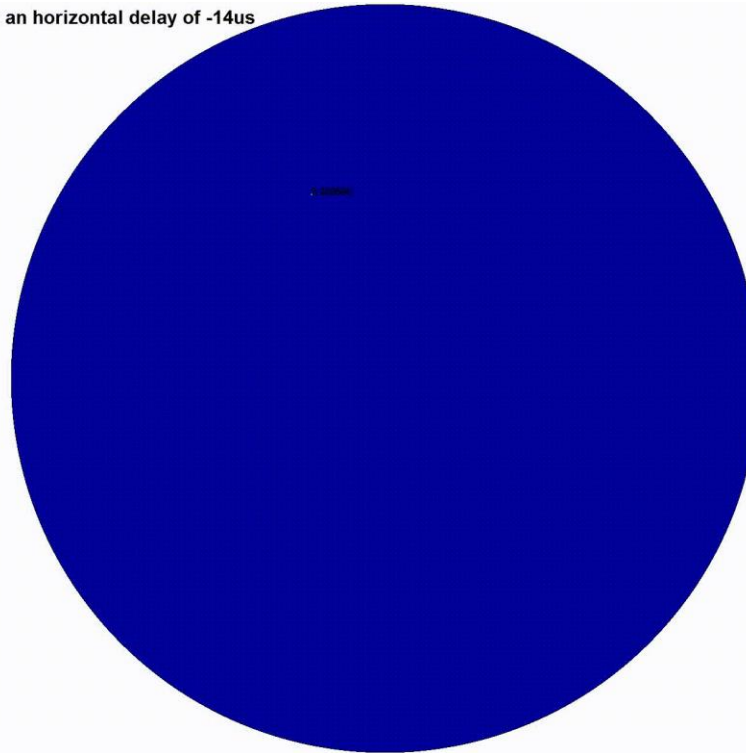

Maximum v. Mises stress	152.6 MPa
Temperature in the peak	106°C
Yield strength at 100°C	250 MPa
Safety factor against yielding	1.63

New Beams and New Demands - Up-Stream Window Summary -

SAFETY FACTOR AGAINST YIELDING

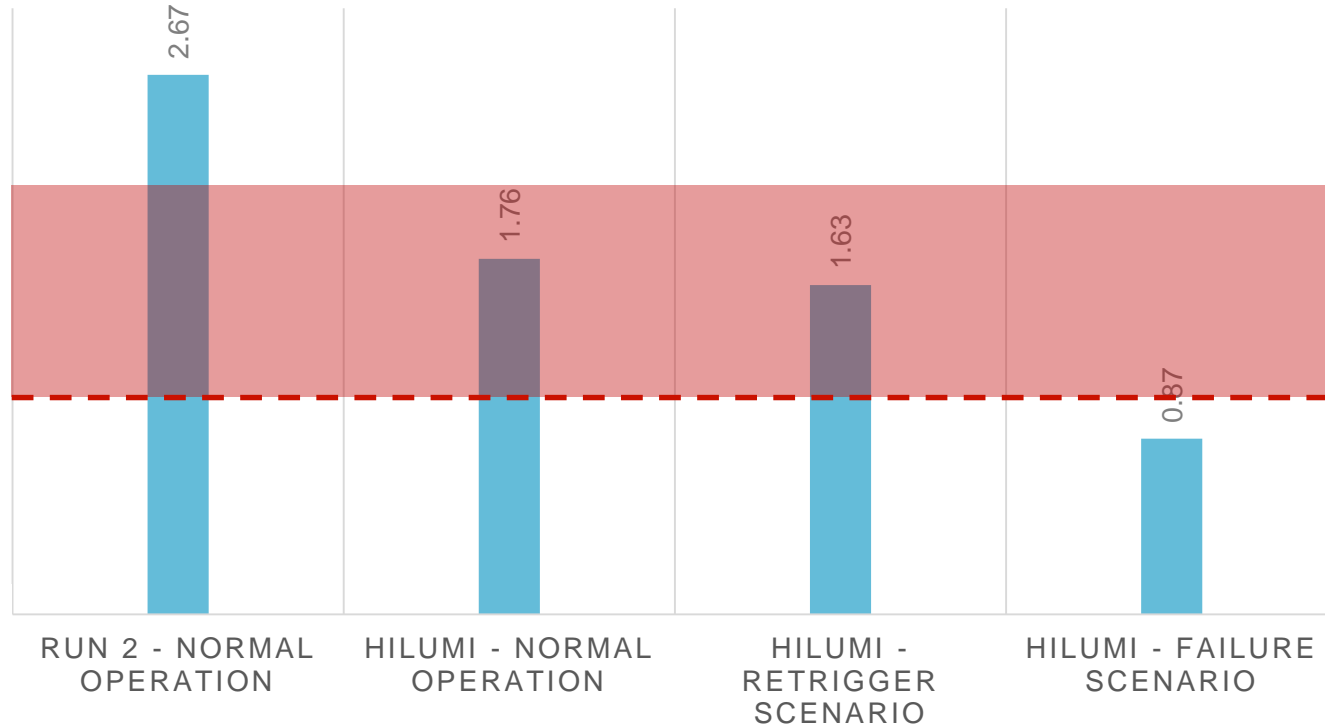

Safety margin
Deals with
uncertainties

Lower limit
Underneath, the
material deforms
permanently

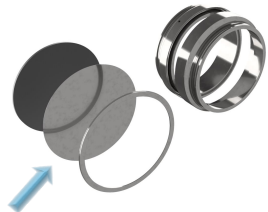

New Beams and New Demands

- Down-Stream Window Standard Run 2 -

TDE - Ti6Al4V Window
 Time = 0
 Contours of Effective Stress (v-m)
 max=0, at elem# 1

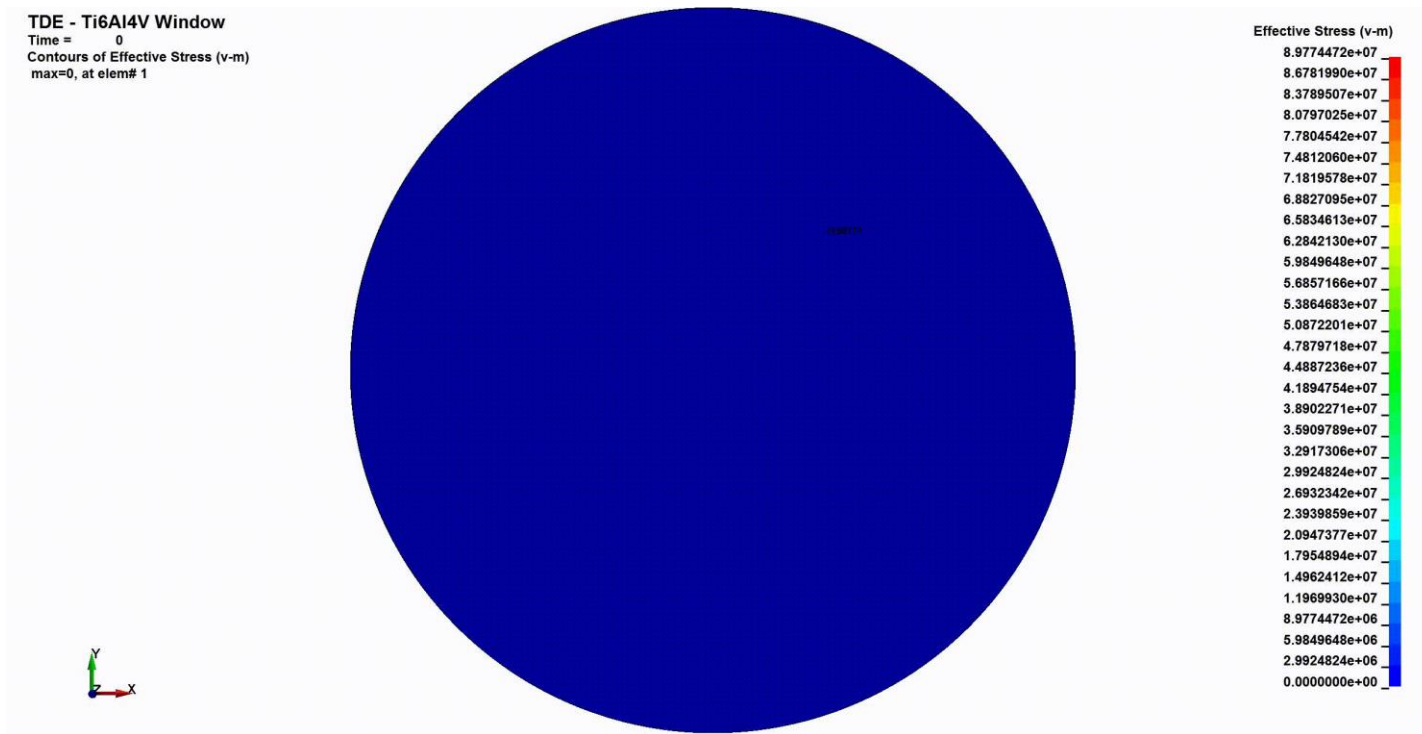

Maximum v. Mises stress	89.8 MPa
Temperature in the peak	81°C
Yield strength at 93°C	280 MPa
Safety factor against yielding	3.12

New Beams and New Demands

- Down-Stream Window Failure HiLumi 6V2H -

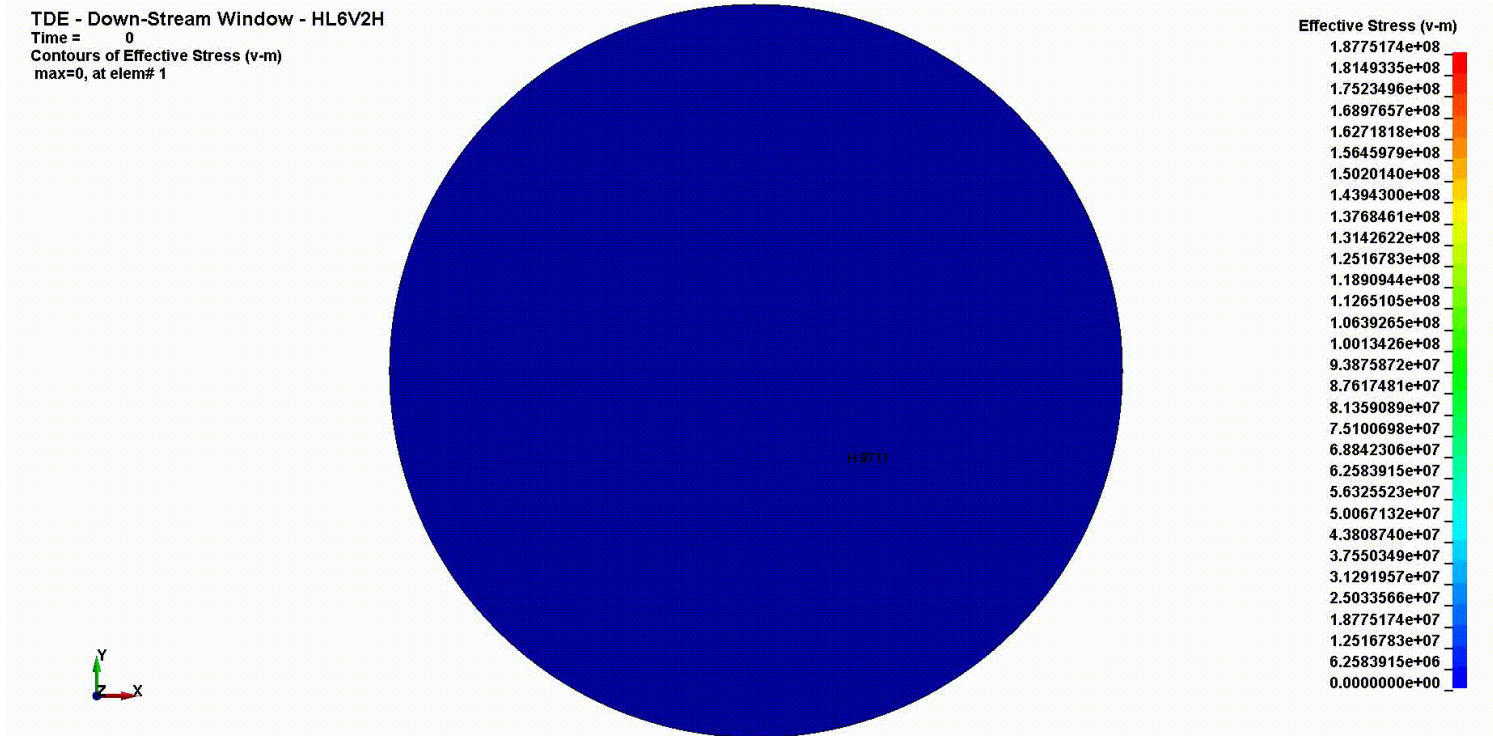

Maximum v. Mises stress	187.8 MPa
Temperature in the peak	145°C
Yield strength at 200°C	140 MPa
Safety factor against yielding	0.74

New Beams and New Demands

- Core -

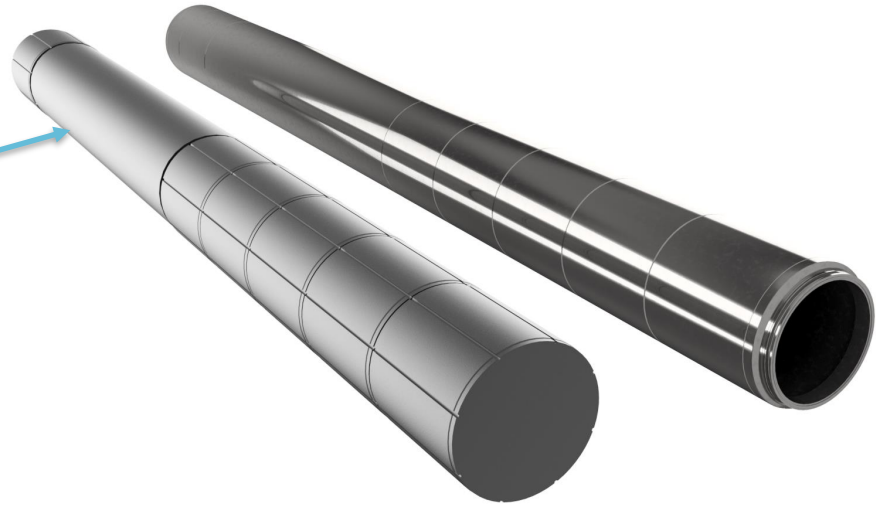

- SIGRAFLEX sheets are 2mm thick
- The core consists of approx. 1700 sheets
- Mechanical tests are very difficult and not finished, yet

Outlook

- Material Characterization -

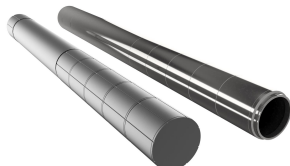
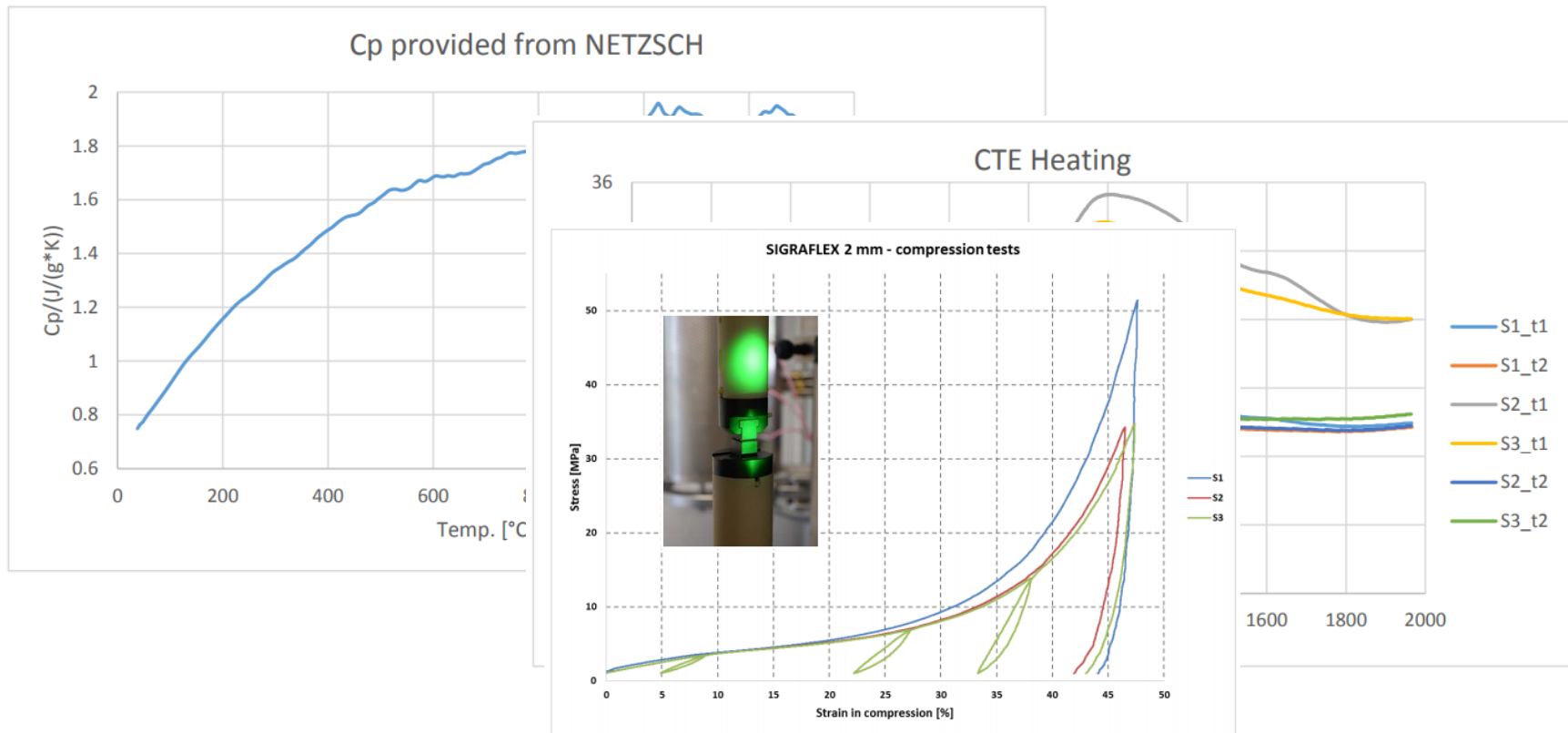

Testing campaign on Sigraflex ongoing
(Thanks a lot to Laura Bianchi and MME!)

Source:
EDMS 1716417

Outlook

- Installed Vibrometers -

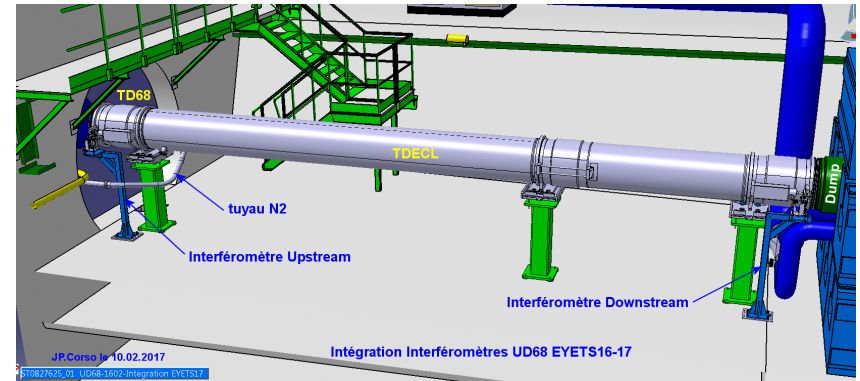
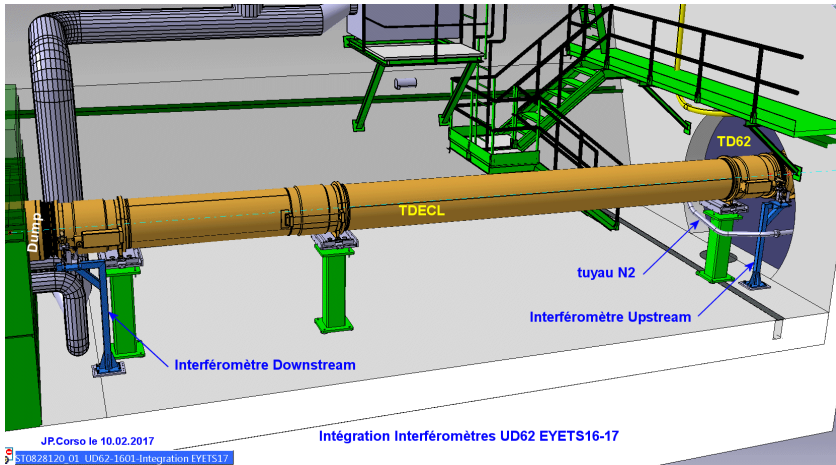

- Simulations are just approximations of the reality
- Vibrometers are installed to verify simulations and to see how good these approximations are

Outlook

- Installed Vibrometers -

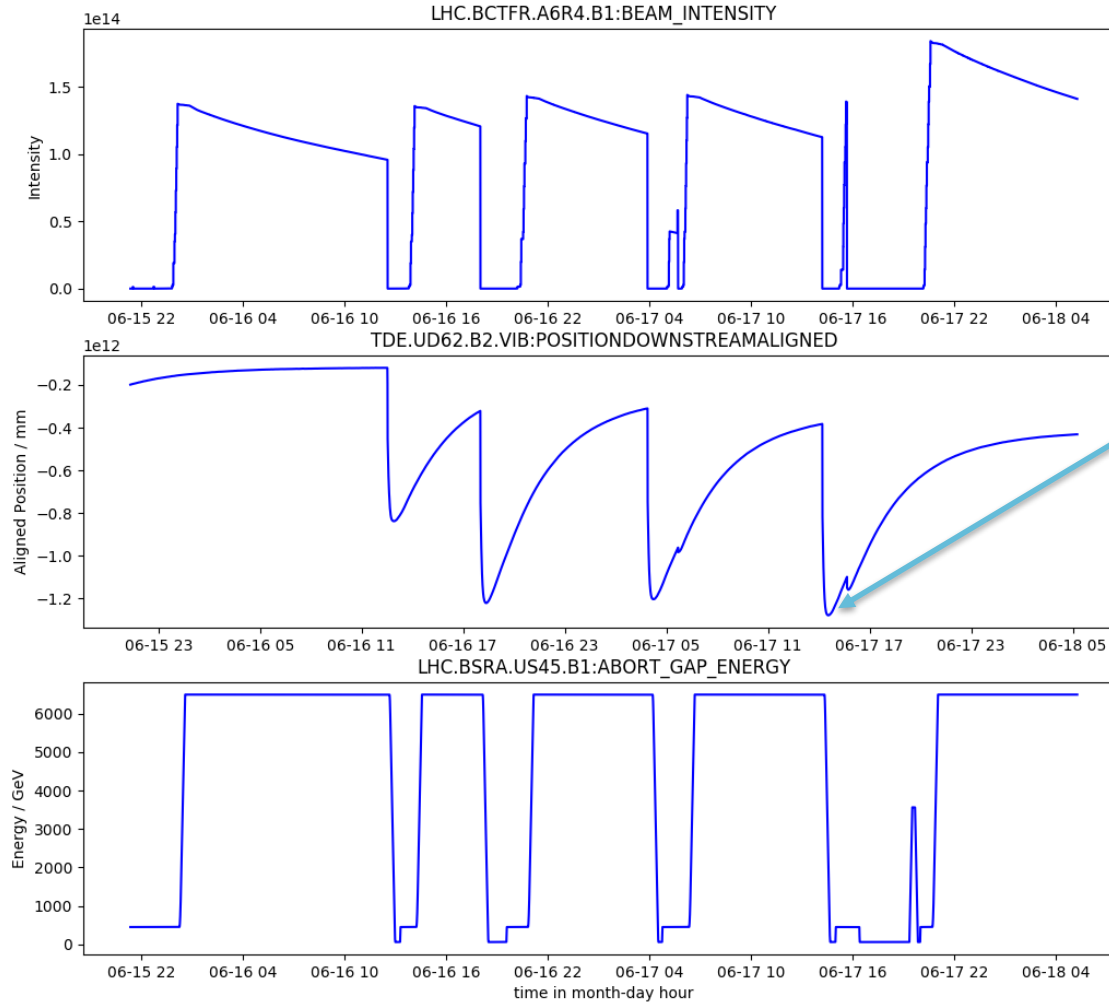

1 mm of displacement!

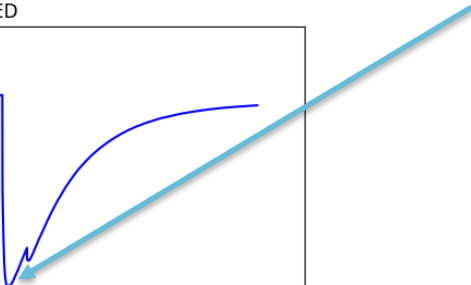

Outlook

- Installed Vibrometers -

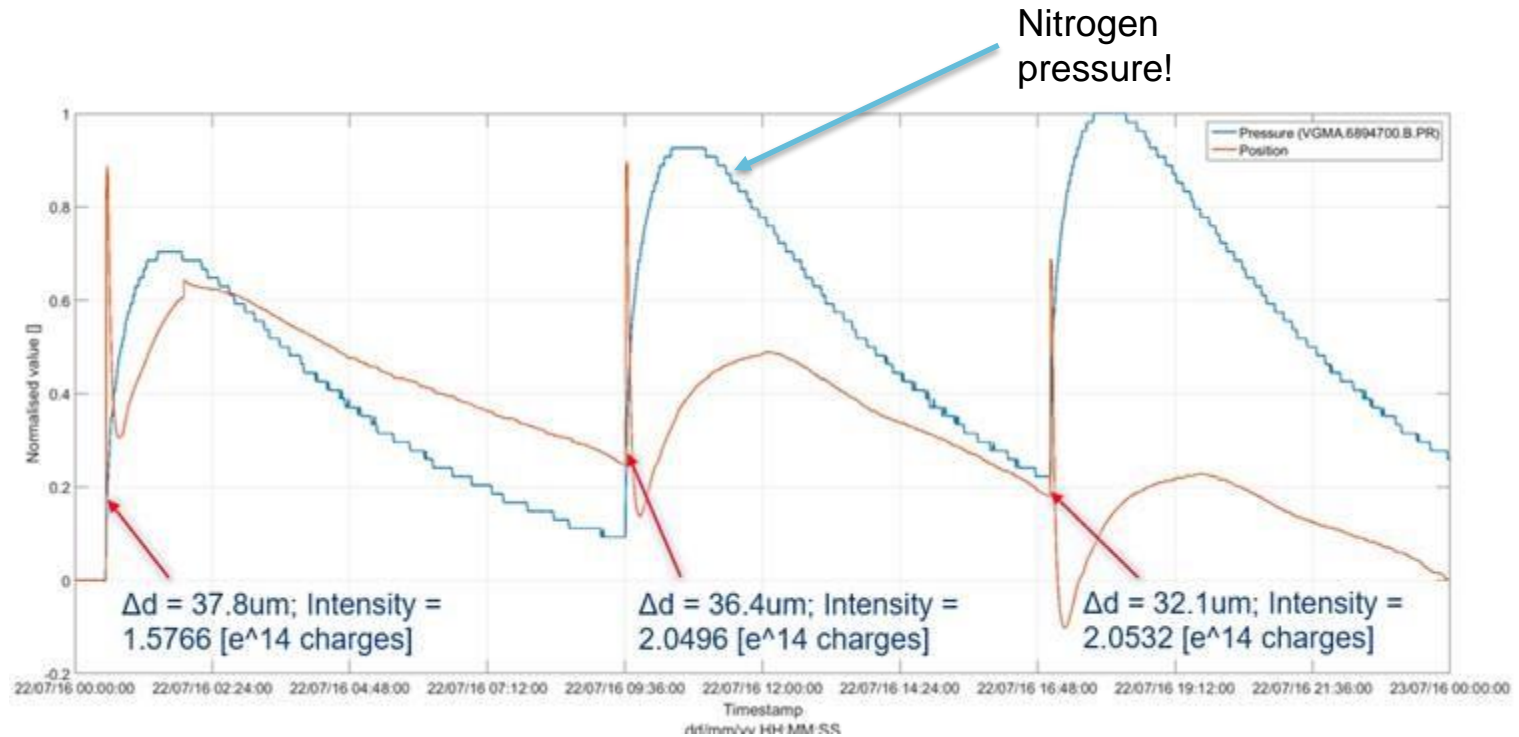

Outlook

- Installed Vibrometers -

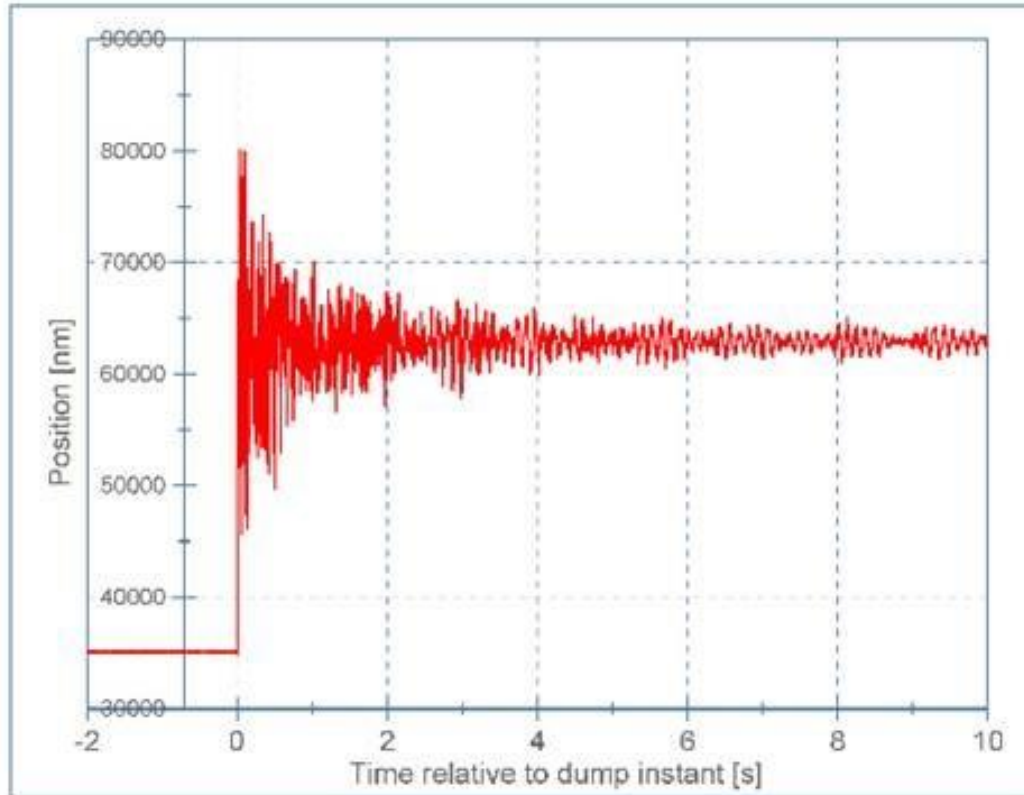

Conclusions

- Both Windows need an upgrade to ensure a safe operation with HiLumi-beams.
- Until now it is not possible to say, if the graphite can sustain a beam impact with Hi-Lumi.
- To evaluate the stresses for the core, material tests are ongoing on SIGRAFLEX.
- **Measurements of the dump response to a dumped beam have to be done to verify the simulations.**
- Vibrometers are already installed to do this in the future



***Thanks to
Matthias Frankl, Christoph Wiesner
Laura Bianchi, Maris Tali,
Antonio Perillo Marcone, Marco Calviani
and to all further contributors to this studies!***

