



# Interlocking for HiLumi – What will be different?

*HL Annual Meeting Madrid 13 – 16 November 2017*

**J. Uythoven**

Many thanks to A. Antoine, A. Balatsoukas, R. Bruce, D. Hogle,  
C. Martin, R. Mompo, I. Romera, R. Secondo, J. Steckert,  
M. Valette, D. Wollmann

# Interlocking for HiLumi – Why it will be different

- Differences because of new HL systems – new hardware to be interlocked with different failure modes
  - 11 T magnets in Point 7
  - Inner triplet CLIQ and Quench Heaters
  - Crab Cavities
  - Hollow e-lens (optional)
  - Beam-Beam wire compensators (optional)
  - New collimators (TCTs and TCLs)
- New interlocking hardware
- New Failure modes due to different operational parameters – pushing performance

# New HL Systems: 11 T Magnet (1/3)

See edms #1764166, 4.3

- Two standard RB dipoles replaced by 11 T dipoles at Point 7, giving the additional required space for collimators in the centre.

- MBA.B8L7 & MBB.B8R7

- The 11 T magnets are connected in series with the RB circuit

- Difference in transfer function between 11 T and standard RB dipoles compensated by a **trim circuit** powering the 11 T magnets

- Trim current between -200 A (-250 A) and +150 A (+100 A)

- Installed in the odd side of the IP

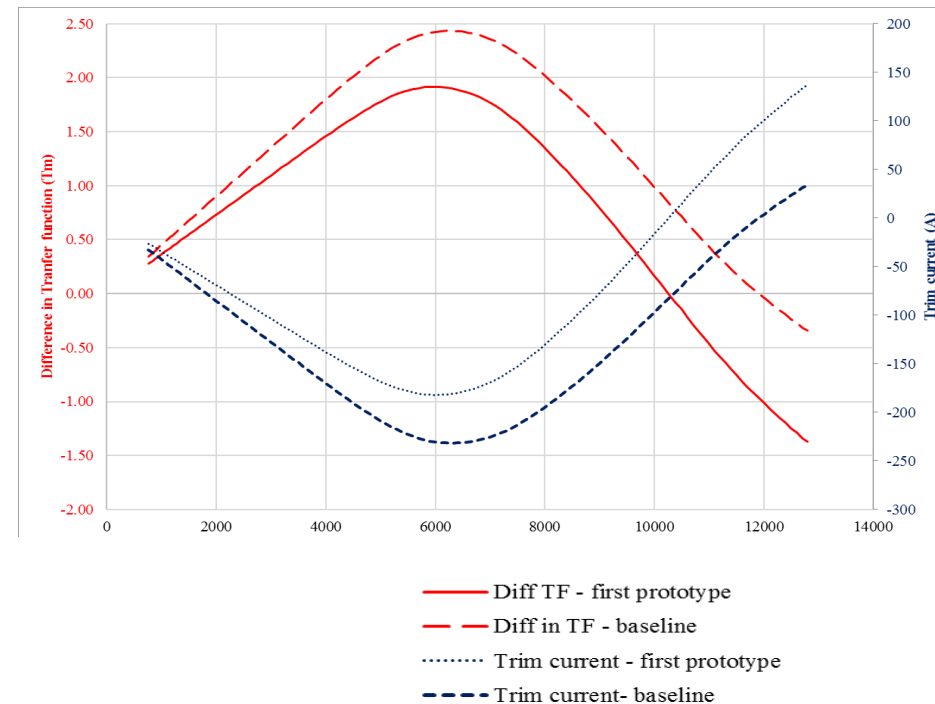
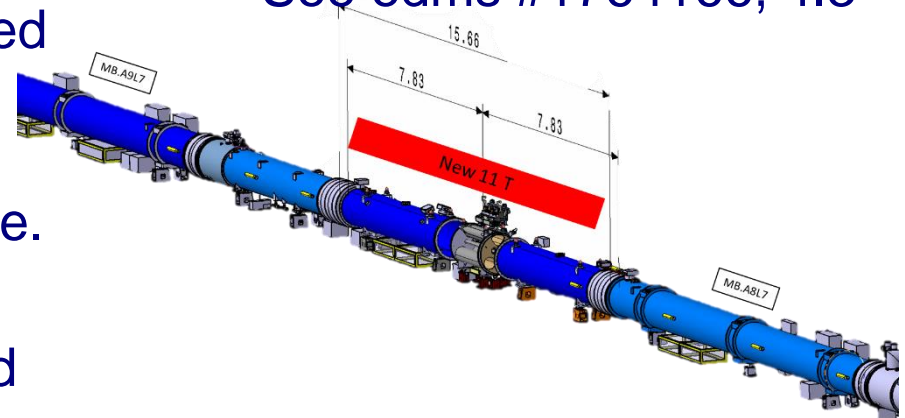

# New HL Systems: 11 T Magnet (2/3)

- Required interlocking of the trim circuit:

Event	Action			
	Dump	FPA Both	SPA main	SPA Trim
Quench of RB or 11 T circuit	X	X*		
Powering failure RB circuit	X		X	
Powering failure Trim circuit	X			X
Switch opening requested by PC of RB	X	X		
Cryo failure	X		X	X

\* How ?

# New HL Systems: 11 T Magnet (3/3)

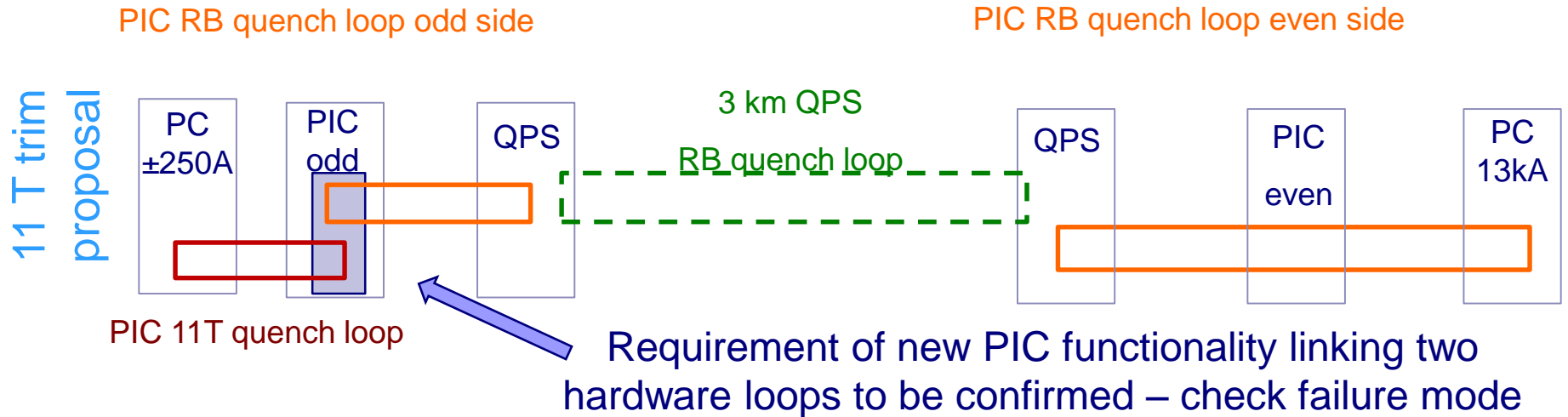

- Independent operation of main and trim circuits
  - Clear diagnostics in case of trim PC interlock
  - No changes to general PIC layout – trim circuit will be like any other circuit
  - The trim quench loop will be opened by the PIC in case of demand by the Global Protection being active → no hardware modification of PIC required
  - **Possibility** to back-up the Global Protection function between the two circuits in **hardware**, linking the two loops
    - This would require some new hardware development and would make these 2 PICs **non standard**
    - To be determined if this is required → check of detailed **failure modes**, could not performing a FPA on the trim circuit damage the magnet?

# New HL Systems: Inner Triplet

- Quench Protection using novel CLIQ system being defined in detail
  - Re-triggering of Quench Heaters and CLIQs in case off erratic being defined in detail
    - Protection of the circuits & magnets
    - Need to ensure to dump the beam before firing the Quench Heaters
- A faster quench loop controller as for the main circuits ?
  - Does the PIC quench loop need its own source for the triplet as well?
  - Do we need better / different / faster PIC diagnostics, can this affect the **PIC2 design**
  - **More details needed**
- Failure Analysis HL Inner Triplet Protection using System Theoretic Process Analysis (STPA): MSc.-thesis by Dennis Hugel

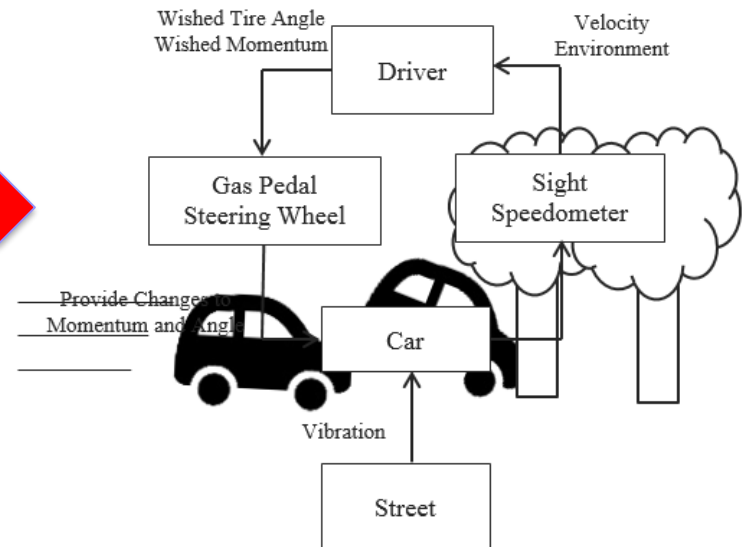
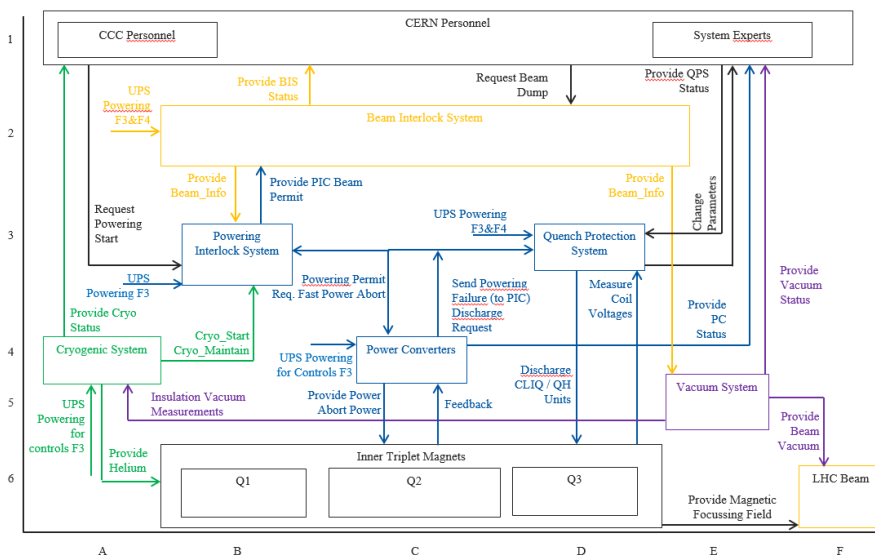

**150 Potentially unsafe control actions which need to be checked & covered**

# New HL Systems – Crab Cavities (1/2)

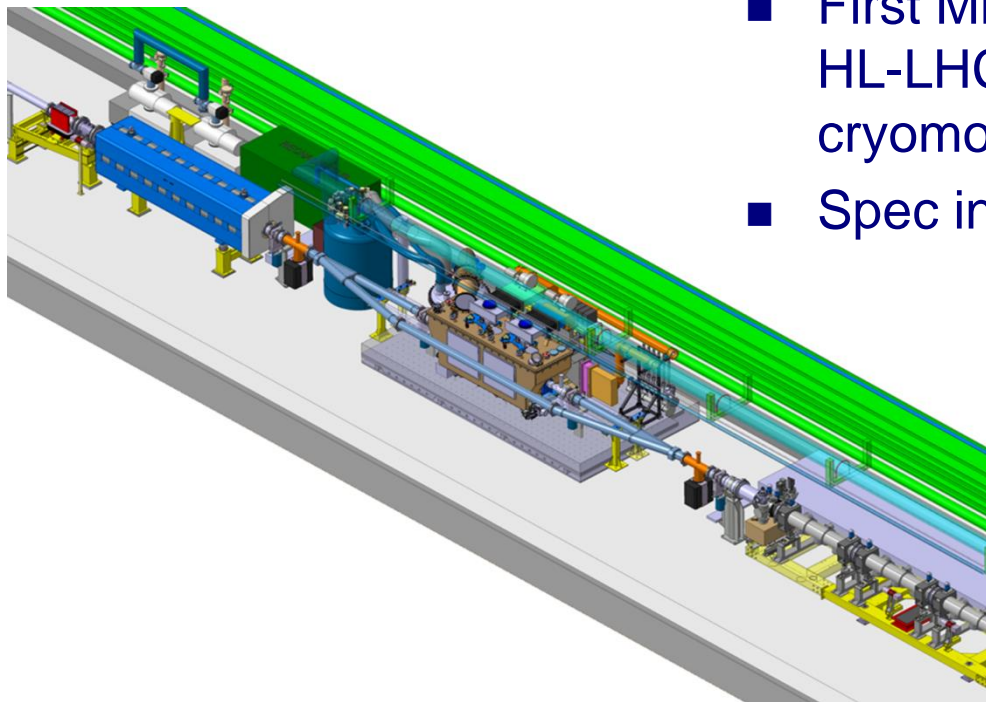

- First Milestone is the installation of two HL-LHC crab cavity modules in a single cryomodule in the **SPS for 2018**
- Spec in edms #1843638 (under prep.)

Test programme foresees to check on cavity failure modes  
Resonant excitation in case of phase detuning failures at low voltage

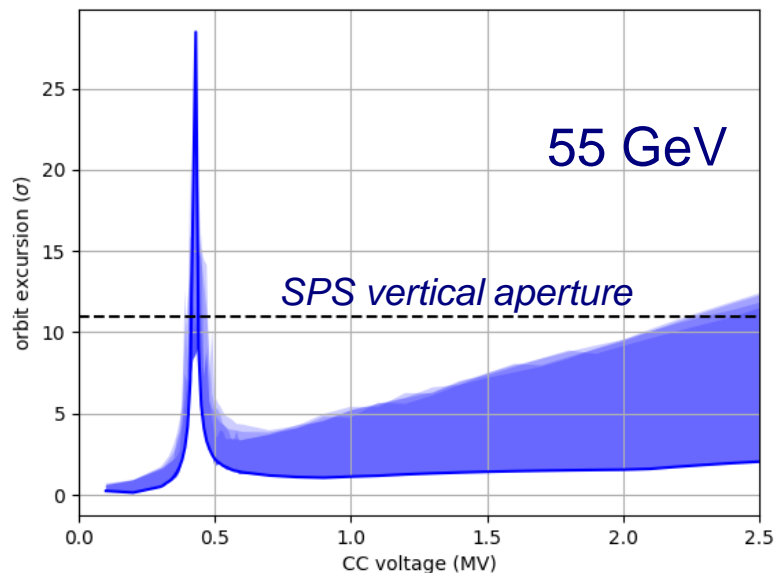

# New HL Systems – Crab Cavities (2/2)

## ■ SPS

- Interlocking based on two User Inputs to the BIS
- SPS Ring BIS → equivalent in the LHC: needs one CIBU
  - RF should be OK, including HOM power
  - Additional BLMs and BPMs: *to be checked if we need them for HL*
- SPS extraction BIS if cavity is ‘in beam’ → aperture restriction, does not apply to LHC
- Interlocking for Personal Safety due to dark current (different chapter, for SPS the CC will be an EIS)

## ■ HL-LHC

- Need most likely one CC BIS entry in case of CC problems
- Fast crab cavity failure modes and effect on beam under study
  - **Learn from the beam experiments in the SPS**
- Up to  $1.5 \sigma$  / turn → fast detection at the Primary Collimators (see later)
- **Need fast detection – not a faster BIS**
  - BIS signal travel time from IP7 to IP6 is already very fast (not redundant)

# New HL Systems – Hollow e-lens

- Not baseline. Will need to have an input to the **PIC**, like other sc magnets

- Interlock on solenoids and bends
- In case of quench, missing dipole kick could cause losses
- **To be checked if reaction time is an issue**

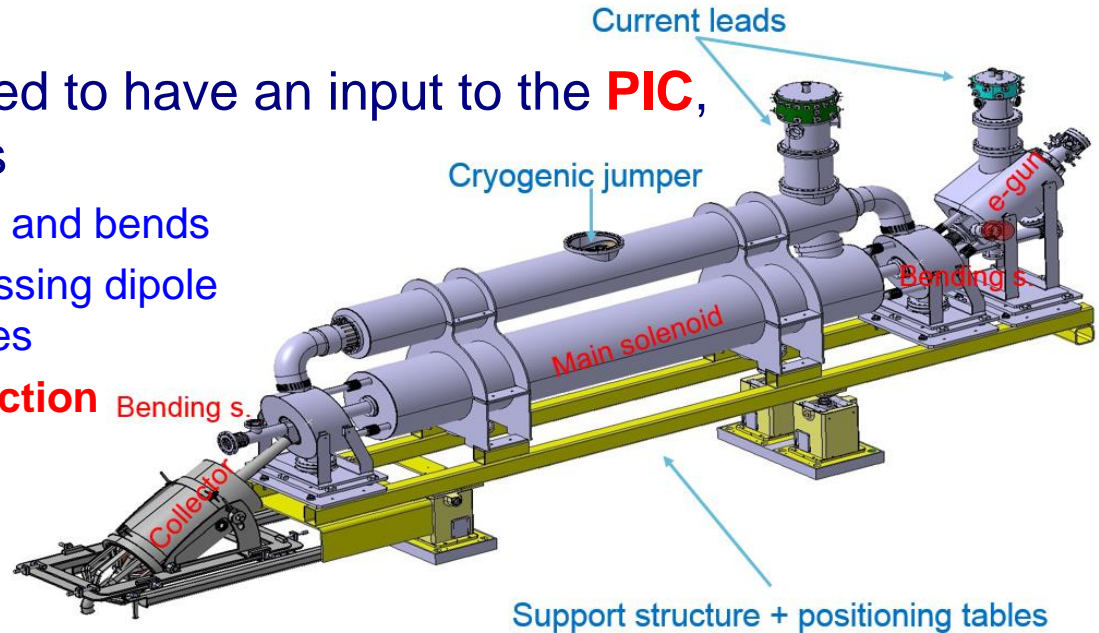

- The challenge will be the operation without beam tails

- No tails – BLMs don't see the big losses coming → core of the beam directly hitting the collimator → very fast rise time of losses
- Mitigate by **witness bunches** with untouched or blown-up halo
- If important for machine protection: **how can we in hardware guarantee the presence of tails ?**
  - This might be one input to the BIS, but we need the detection system !
- If depleted halo is obligatory (like for crab cavity failures) → **need to interlock as well on depletion of tails of the majority of the bunches** → need more details !

# New HL Systems – New Collimators

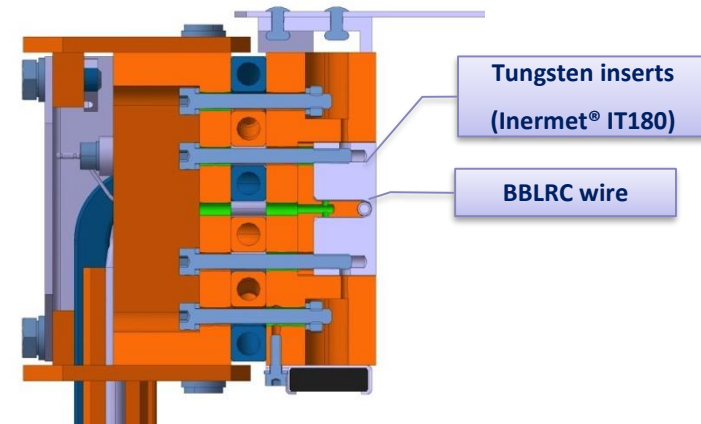
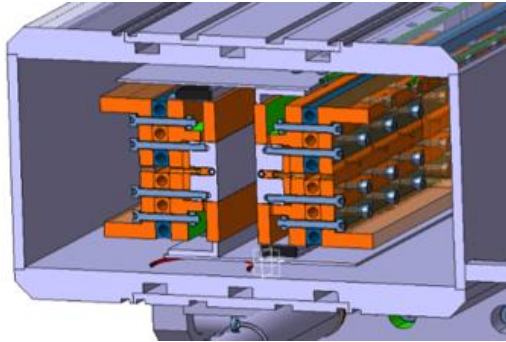

- Wire in-jaw collimator
  - Not part of the baseline but already 2 → 4 installed in the LHC
  - The overheating of the wire is protected by a connection to the **WIC** – standard warm magnet interlock control system – based on voltage measurement over the wire
    - Voltage measurement will need a more reliable solution – isolation amplifier etc. – if it becomes baseline
  - No dangerous failure modes to the beam detected, but to be interlocked
- If crystal becomes part of baseline, few more changes to the interlocking, but nothing fundamental
- TCTs and TCLs
  - No difference relative to today
  - Possibly SIS interlocks on the TCT BPMs

# New Interlocking Hardware

- All interlock systems will by the time of LS3 have obsolete electronics, V2 of all interlock systems:
  - BIS2, SMP2, PIC2, FMCM2, WIC2
- Following the above, the Functional Specification of these systems is not going to be very different from the present systems - see previous slides
- Only system where development has started is the Beam Interlock System BIS, with the intermediate version BIS1.23 which *could* be implemented for 2023 if required
  - Optical part of the BIS: weakest part of a strong system – for which an alternative is presently being studied

# Beam Interlock System Developments

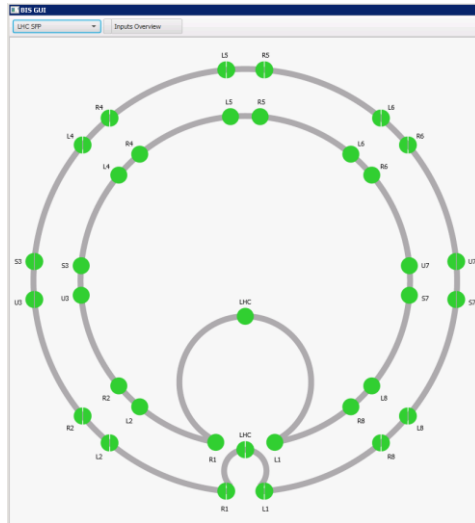

Two new BIS loops have been installed in parallel of the operation LHC BIS loops

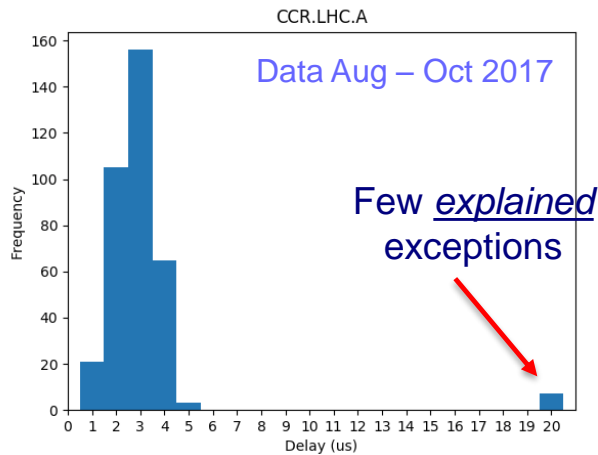

Delay in  $\mu$ s between operational and test loop local permit when beams are dumped: OK



Current CIBO module:

- Home made
- Low power margin
- High temp drift
- No monitoring



New SFP module:

- Industrial standard
- High output power
- Low temp drift
- Monitoring function

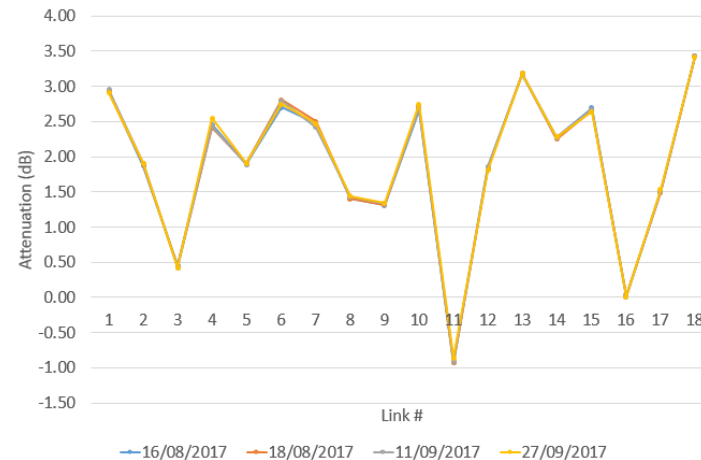

Measured attenuation of new LHC optical fibre links installed in the LHC: Very Stable !  
*Don't need to disconnect to measure the power*

# BIS → BIS 1.23 → BIS 2

LS2\*

LS3

\* If required

## ■ Expected changes in Functional Specification

- Number of users per Beam Interlock Crate
- Also issue for SPS
- Rigidity of inputs B1 – B2 – Both Beams and Maskable or not

## ■ Expected changes Technical Specification

- Power monitoring of optical loops
- Bus system – stay with VME ?
- Use of a third optical loop for monitoring ?
- Link to Safe Machine Parameters

## ■ Unchanged

- Reliability
- Delay
- Modularity and scalability
- Standard User Inputs

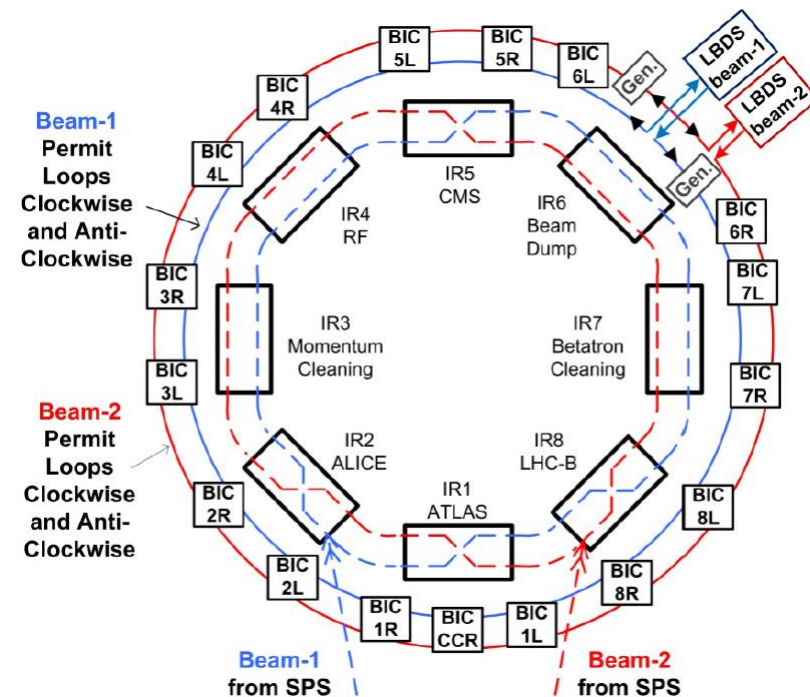

### BIS 1.23 Tests:

- For 2018 include additional TSU from Beam Dumping System in the test loop
- Introduction of 'False' frequency

# Conclusions: Interlocking HL-LHC

- HL-LHC will be more critical to operate
  - Very high intensity bunches, fast instabilities – like 16L2 – need a very reliable beam interlocking system
  - The criticality of having **depleted tails** and the presence of **witness bunches** need to be studied in further detail for specific failure modes
  - This might require new (redundant) hardware; fast detection systems in IP7;  $dI/dt$  on witness bunch with ADT?
  - If BB wire collimator: more reliable interlocking as input to the WIC required
- Effect on the interlock systems
  - Additional clients to the BIS which would be covered by present system
  - Minor effect on the V2 of the present interlock system is expected
  - BIS V2 will **not** need to be faster – fast failures to be caught by the beam at the TCP/TCS in point 7
  - PIC V1 for 11 T might need to link two quench loops in hardware – non standard – study of failure modes ongoing to determine if this required
  - PIC V2 design needs further input / study of requirements for inner triplet protection
- BIS V2
  - First promising tests in the LHC of new optical loops using SFP. Tests with TSU foreseen for 2018.