



Detailed global view on protection and detection of the circuits

R. Denz

Acknowledgements:

A. Ballarino, S. Izquierdo Bermudez, G. Kirby, M. Mentink,
F. Rodriguez Mateos, H. Prin, A. Siemko, J. Steckert, A.
Verweij, D. Wollmann, S. Yammine



7th HL-LHC Collaboration Meeting, Madrid, November 16th 2017



Circuit Table v7.2-1

	Circuits for HiLumi	Magnet Type	Quench Heaters	CLIQ	EE	Required QDS	References
Inner Triplet	Triplet Q1, Q2a, Q2b, Q3	MQXFA / MQFXB	Baseline (inner/outer layer)	Baseline	no	QDS_MAG, QDS_LNK, QDS_HTS, QDS_BB	
	Trim Q1	-					
	Trim Q1a	-					
	Trim Q3	-					
	Orbit correctors Q2a/b - vertical	MCBXFB	Baseline	no	Option	QDS_MAG, QDS_LNK, QDS_HTS, QDS_BB	
	Orbit correctors Q2a/b - horizontal	MCBXFB	Baseline	no	Option	QDS_MAG, QDS_LNK, QDS_HTS, QDS_BB	
	Orbit correctors CP - vertical	MCBXFA	Baseline	no	Option	QDS_MAG, QDS_LNK, QDS_HTS, QDS_BB	
	Orbit correctors CP - horizontal	MCBXFA	Baseline	no	Option	QDS_MAG, QDS_LNK, QDS_HTS, QDS_BB	
	Superferric, order 2	MQSXF	no	no	PC Crowbar / EE Option	QDS_MAG, QDS_LNK, QDS_HTS	
	Superferric, order 3, normal and skew	MCSXF / MCSSXF	no	no	PC crowbar	QDS_LNK, QDS_HTS	
	Superferric, order 4, normal and skew	MCOXF / MCOSXF	no	no	PC crowbar	QDS_LNK, QDS_HTS	
	Superferric, order 5, normal and skew	MCDXF / MCDSXF	no	no	PC crowbar	QDS_LNK, QDS_HTS	
	Superferric, order 6	MCTXF	no	no	PC crowbar	QDS_LNK, QDS_HTS	
Superferric, order 6, skew	MCTSXF	no	no	PC crowbar	QDS_LNK, QDS_HTS		
D1	Separation dipole D1	MBXF	Baseline	no	no	QDS_MAG, QDS_LNK, QDS_HTS, QDS_BB	
D2	Recombination dipole D2	MBRD	Baseline	no	no	QDS_MAG, QDS_LNK, QDS_HTS, QDS_BB	
	Orbit correctors D2	MCBRD	no	no	PC crowbar / EE Option	QDS_MAG, QDS_LNK, QDS_HTS, QDS_BB	
Q4	Individually powered quad Q4 (1.9K)	MQY	Baseline	no	no	QDS_MAG, QDS_HTS, QDS_BB	
	Orbit correctors Q4 (1.9K)	MCBY	no	no	PC crowbar		
Q5	Individually powered quad Q5 (1.9K)	MQY	Baseline	no	no	QDS_MAG, QDS_HTS, QDS_BB	
	Orbit correctors Q5 (1.9K)	MCBY	no	no	PC crowbar		
Q6	Individually powered quad Q6 (4.5K)	MQML	Baseline	no	no	QDS_MAG, QDS_HTS, QDS_BB	
	Orbit correctors Q6 (4.5K)	MCBC	no	no	PC crowbar		
11T	11T dipole, MBH	11T dipole, MBH	Baseline	no	existing RB EE	QDS_MAG	
	Trim circuit	-					

Instrumentation

- All voltage taps used for quench detection are redundant
- All corrector circuits requiring active quench detection systems are equipped at least with a midpoint voltage tap
 - In specific cases the “midpoint” voltage tap must be located asymmetrically
 - In case dedicated detection systems for the bus-bars are regarded as useful, the respective voltage taps must be provided
- HTS leads and MgB_2 links will be equipped with their respective voltage taps
 - Routing of the link instrumentation wires through the cold part is not required
- Voltage taps may be specified and added for diagnostic purposes only; the corresponding signals can be processed by the QPS supervision

Current sensors

- Dedicated current sensors for quench detection systems will be used for all the circuits requiring current depending detection settings
 - Nb_3Sn magnets, corrector circuits
 - Required resolution is low \rightarrow resistive part of HTS current lead could serve as sensor
- Newly developed didt sensors will be installed for various purposes:
 - Improved symmetric quench detection, e.g. for Q4, Q5, Q6
 - Better compatibility of certain corrector magnet circuits with HL-LHC operational requirements e.g. higher acceleration, fast feed back
 - IT orbit correctors in point 2 and 8, sextupole correctors ...

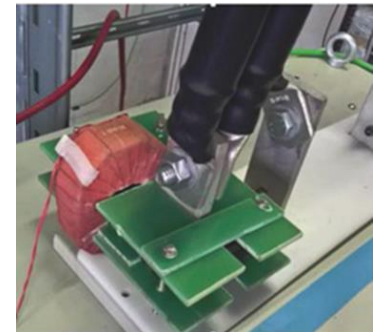

Interlocks

- The HL-LHC interlock architecture is derived from the standard LHC interlock specification
- Hardwired interlocks:
 - Current loops linking the power converter(s), the powering interlock controller (PIC), the energy extraction system (if applicable) and the quench detection systems.
 - Any rupture of the current loop will stop the power converter. The PIC initiates a beam dump request via the beam interlock controller.
 - CLIQ and quench heater power supplies (DQHDS) are directly triggered by the quench detection systems (active high); these units will be equipped with redundant trigger inputs.
 - In case of a self-triggering CLIQ unit all CLIQ units will fired
- HL-LHC will use redundant fast interlocks
 - Beams will be dumped prior to CLIQ and DQHDS activation

Detection settings

Element	Threshold	Evaluation time	Remark
MQXF, MBXF, MBRD, MBH	± 100 mV	10 ms	Higher thresholds at lower currents may be required e.g. ± 200 mV for $I < 2$ kA
Corrector magnets	± 100 mV	10 ms	Longer evaluation times may be required in certain cases. High threshold at low current recommended e.g. ± 2 V for $I < 50$ A
HTS lead - resistive part	± 100 mV	1 sec	
HTS lead – HTS part	± 1 mV - ± 5 mV	100 ms	
MgB ₂ cables	50 mV – 100 mV	100 ms	

- Detection settings are still preliminary (besides the ± 100 mV, 10 ms of course ...) and need to be confirmed.

Inner triplets

- **Quench Detection Systems (QDS):**
 - Magnets, bus-bars, MgB₂ links, HTS leads
 - Dedicated QDS for the different elements; detection settings can be specified accordingly
- **Protection systems:**
 - Quench heaters (inner & outer layer), CLIQ
 - 24 + 48 DQHDS, 6 CLIQ units
- **Protection strategy:**
 - Any detection trigger will activate all CLIQ and Quench Heater Discharge Power Supplies (DQHDS)

Inner triplet – instrumentation scheme Q1a & Q1b

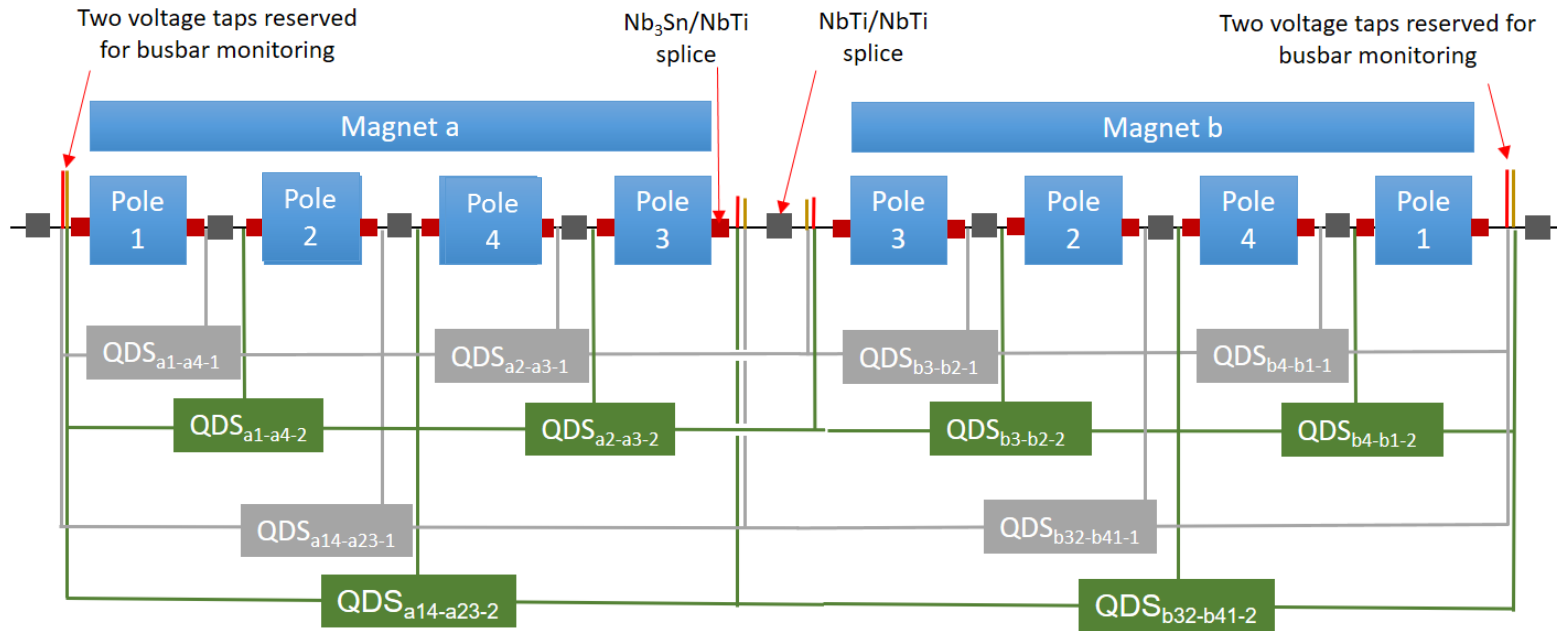

- Q1a and Q1b each have unique individual currents, so that a finer subdivision of balanced sections is needed
- Two layers of quench detection, and two-fold QDS redundancy
 - 1st layer: balanced individual poles (e.g. pole 1 vs pole 4) → 2 x QDS channels
 - 2nd layer: balanced groups of two poles (e.g. poles 1+4 vs 2+3) → 2 x QDS channels
 - Total: 12 x QDS channels for Q1

Inner triplet – instrumentation scheme Q2 & Q3

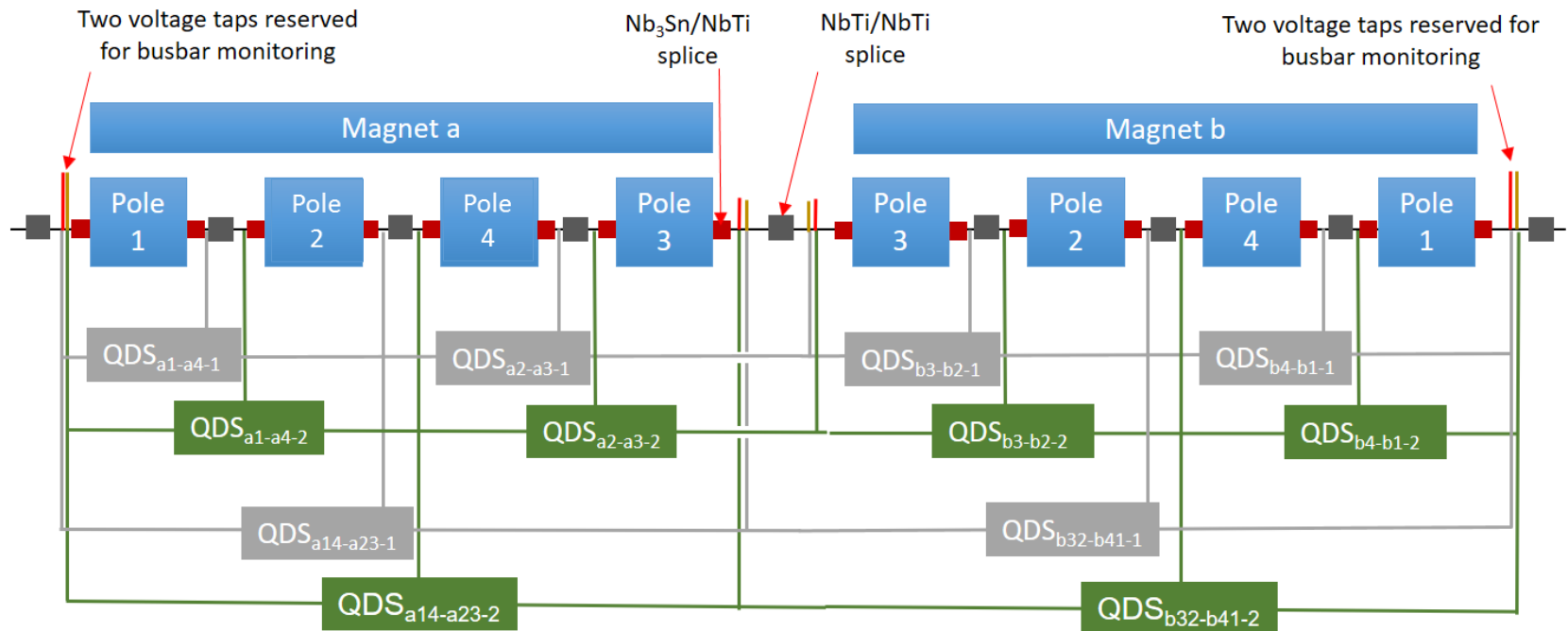

- Same current for: Q2a and Q2b, and Q3a and Q3b → less QDS detectors are needed
- Groups of two poles are balanced against each other (e.g. poles 1 & 4 versus 2 & 3) → 2 x QDS channels
- Magnets are balanced against each other (Magnet a vs b) → 2 x QDS channels
- Total: 6 x QDS channels for Q2, and 6 x QDS channels for Q3

Inner triplet – bus-bar quench detection scheme

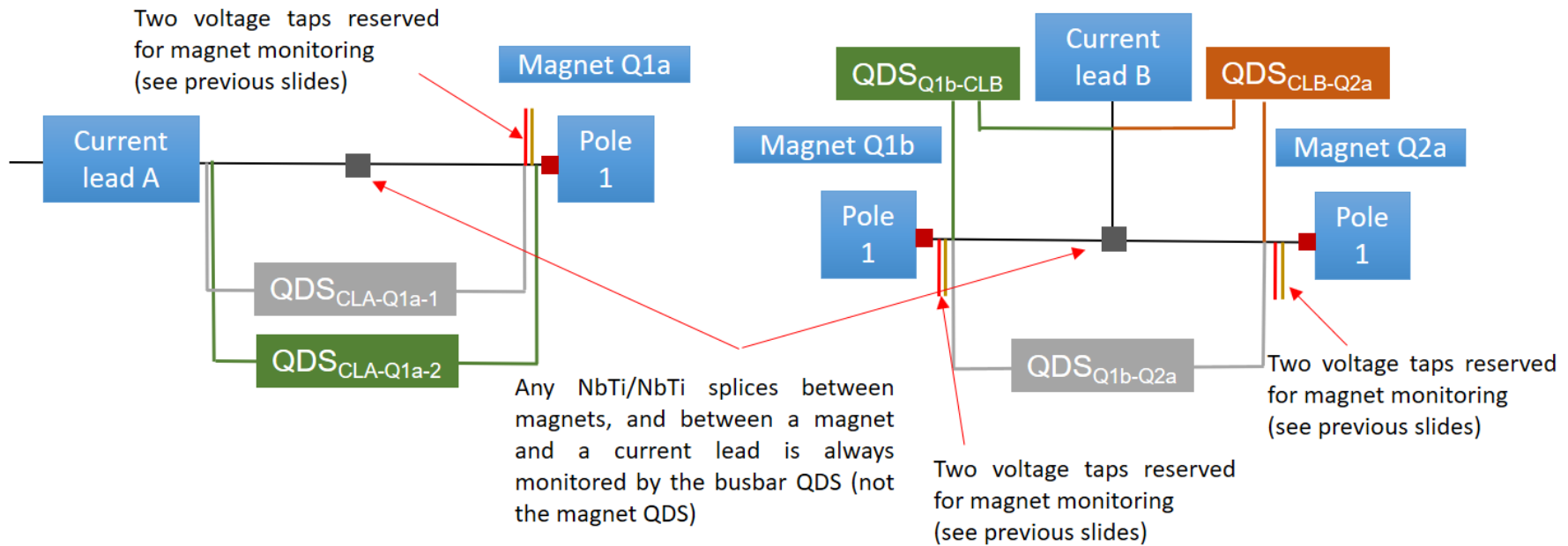

- Bus-bar protection underneath current leads A and E: 2 x 2 QDS channels monitoring bus-bars
- Bus-bar protection for T-sections between Q1a-Q2a, and Q2b-Q3a: 2 x 3 QDS channels monitoring bus-bars
- Bus-bar between Q2a and Q2b is monitored by the magnet QDSs

Inner triplet – instrumentation summary

Summary	Qty	Voltage taps	QDS channels
Magnets	6	6 x 2 x 7 or 6 x 2 x 5	12 (Q1) + 6 (Q2) + 6 (Q3)
HTS leads	5	5 x 2 x 4	10
SC link	5	5 x 2 x 2	10
Total		164 or 120	54

- Final voltage tap configuration still to be confirmed.
- Routing of voltage taps and required twisting to be confirmed.

Inner triplet – correctors

- Orbit correctors (MCBXF):
 - QDS: magnets, bus-bars, MgB₂ links, HTS leads
 - Protection systems: energy extraction by PC crowbar; optional energy extraction systems
- Superferric order 2 (MQSXF):
 - QDS: magnets, bus-bars, MgB₂ links, HTS leads
 - Protection systems: energy extraction by PC crowbar; optional energy extraction systems
- Superferric order 3, 4, 5, 6:
 - QDS: MgB₂ links, HTS leads
 - Protection systems: energy extraction by PC crowbar

D1, D2 and D2 corrector

- D1 and D2 dipoles:
 - QDS: magnets, bus-bars, MgB₂ links, HTS leads
 - Dedicated QDS for the different elements; detection settings can be specified accordingly
 - Protection systems: quench heaters
 - 4 (D1) x DQHDS, 8 (D2) x DQHDS
- D2 corrector
 - QDS: magnets, bus-bars, MgB₂ links, HTS leads
 - Protection: energy extraction by PC crowbar; optional energy extraction system
 - As the CCT magnet could experience symmetric quenches, each of the two apertures will be equipped with a non-central tap

Q4, Q5 and Q6

- QDS: magnets, bus-bars, HTS leads → refurbished existing LHC systems adding additional features
 - Dedicated QDS for the different elements; detection settings can be specified accordingly
 - Enhanced quench heater circuit supervision
 - Improved symmetric quench detection with the help of didt sensors
- Protection systems: quench heaters
- Q4, Q5 and Q6 correctors
 - Protection by PC crowbar detection by PC as presently implemented in LHC for 60 A and 120 A corrector circuits

11 T dipoles

- QDS:
 - Magnet and bus-bars inside 11 T assembly
 - nQPS layer of RB circuits needs to be re-configured after installation of 11 T dipoles
- Protection systems:
 - Quench heaters, energy extraction systems of main circuits
 - 2 x 8 DQHDS

11 T – instrumentation scheme

MB_R substitution

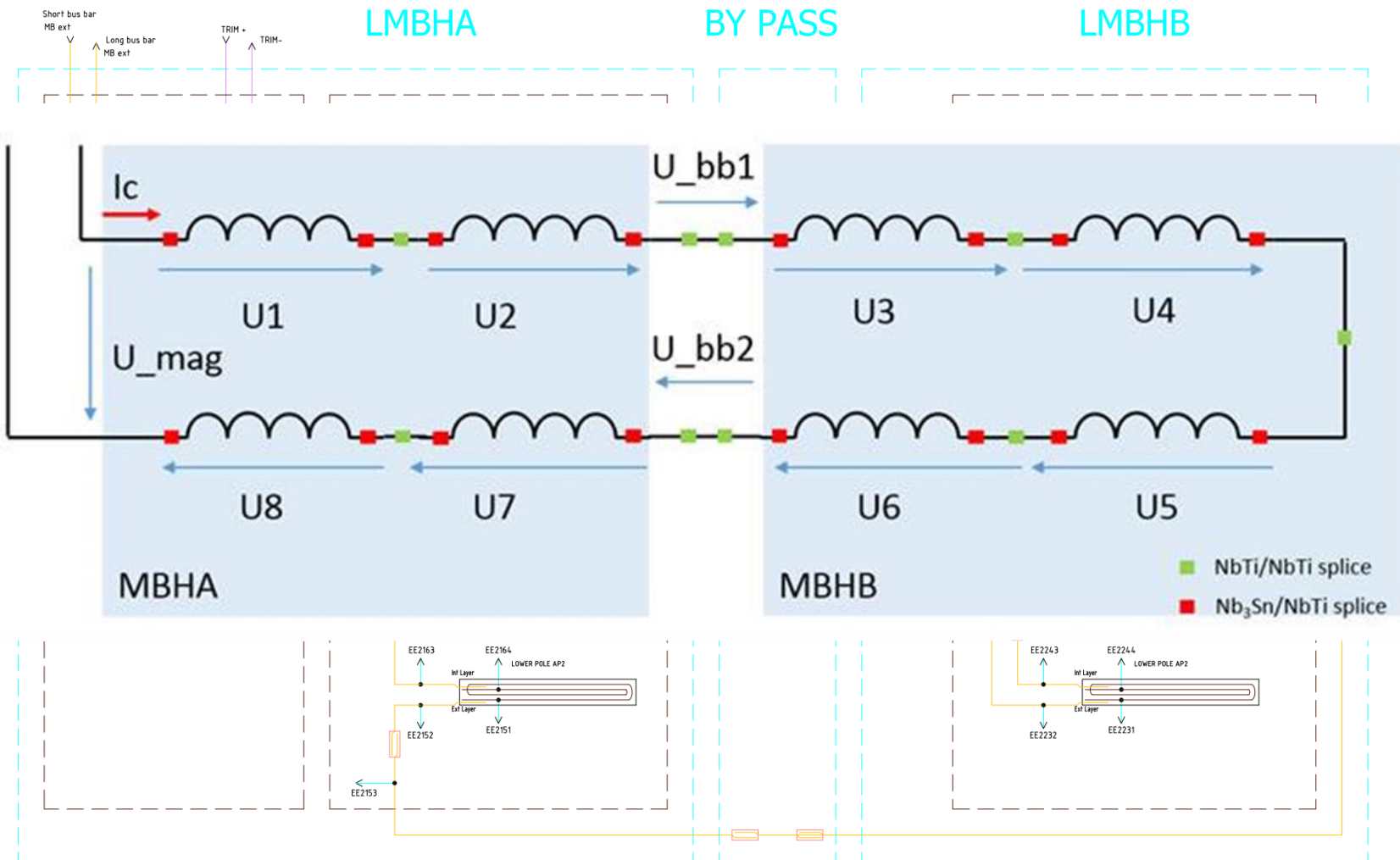

11 T – instrumentation summary

- In total 16 magnet voltages, four bus-bar voltages, two total magnet voltages and two circuit currents are treated by the redundant QDS systems
- Detection of aperture symmetric quenches will be assured by comparing MBHA with MBHB
- The choice of taps will always include bus-bars and splices around the concerned magnet pole so that all internal bus-bars are covered by QDS
- nQPS for RB.A67 and RB.A78 needs to be re-configured as 11 T dipole cannot be used as reference magnet
- See as well LHC-MBH-ES-0001 EDMS 1764166 (under approval)

Summary

- Definition of protection of the various HL-LHC superconducting circuits advancing well and almost concluded
 - Still some open questions like optional energy extraction systems
- Detailed implementation of instrumentation schemes started
 - Completed for 11 T dipoles
 - Some details to be clarified for inner triplets
 - Still to be done for D1, D2, correctors etc.
- Quench detection algorithms and settings established
 - Based on present knowledge about the magnets and other superconducting elements
 - Final validation after tests with prototypes