



Detection of beam losses in the triplet and cold BLM sensitivity

A. Tsinganis, F. Cerutti, A. Lechner (EN/STI/FDA)
with A. Mereghetti, Y. Zou (BE/ABP)

7th Annual HiLumi Collaboration Meeting – Madrid, November 13-16, 2016

Outline

- Introduction
- Layout and optics
- Loss scenario
- Results
 - Peak power density in coils
 - BLM response
 - “cryoBLM” response
- Summary

Introduction

- Goals of this study:
 - First calculation of BLM pattern in the Hilumi triplet for stable operation and for a loss scenario in IR5
 - Disentangling of losses and collision debris
 - Evaluation of “cryoBLM” effectiveness with respect to conventional BLMs



Layout, optics and loss scenario

Simulated geometry (triplet-D1)

- HL-LHC V1.3 (255 μ rad half crossing angle, $\beta^*=20$ cm)

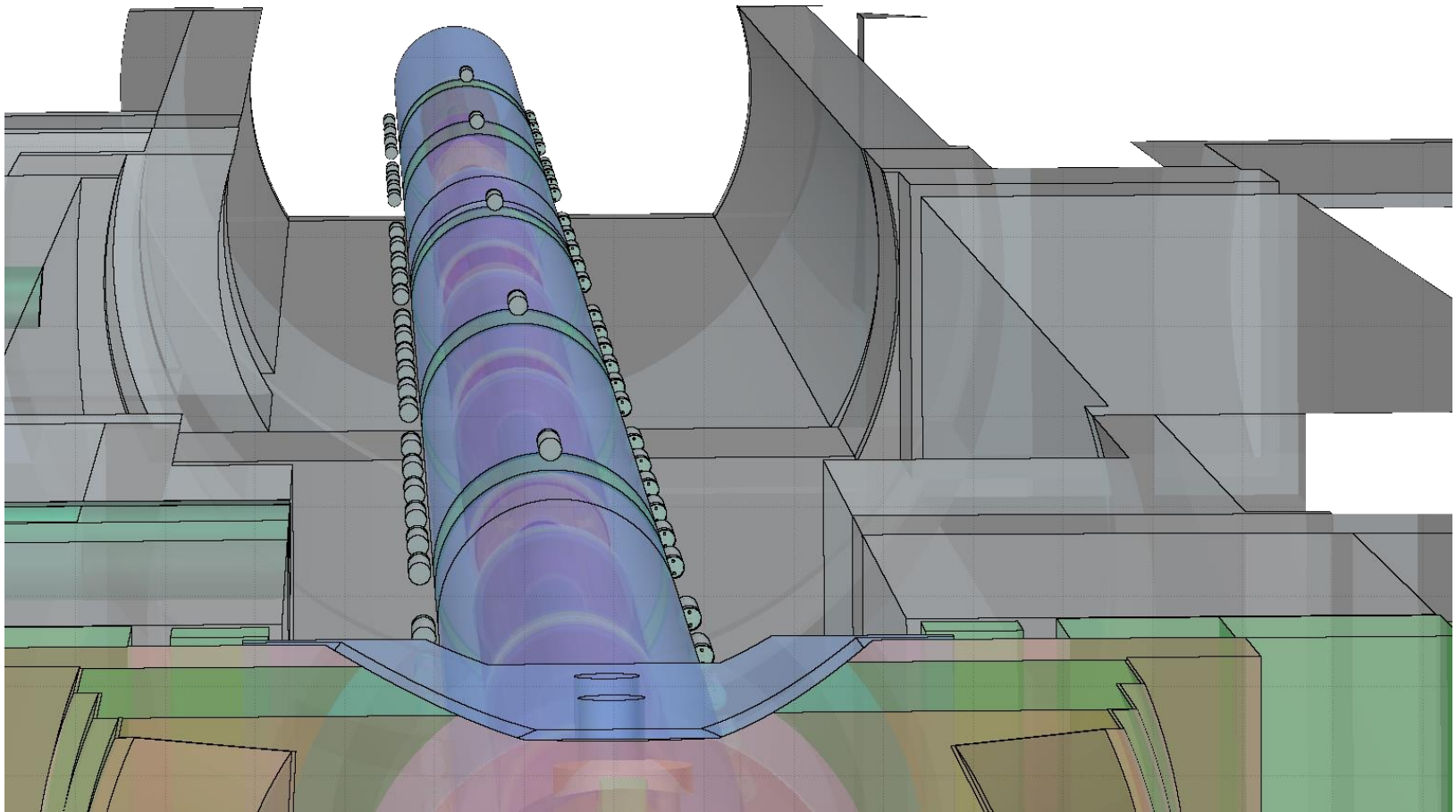

Simulated geometry (triplet-D1)

- Several BLMs placed to obtain a finer-grained information

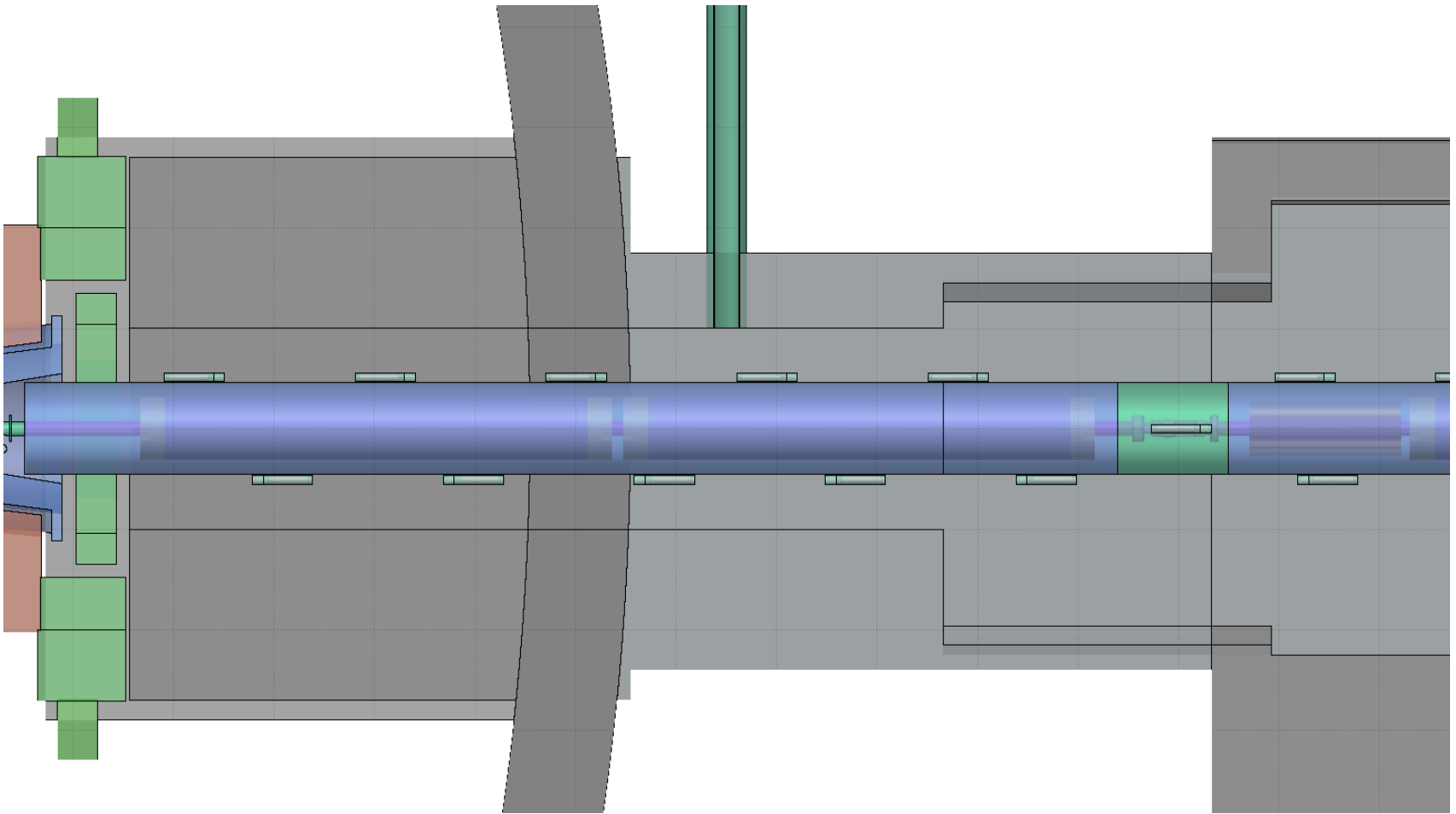

Scoring for “cryoBLMs”

- Additional scoring added on the interconnect flanges

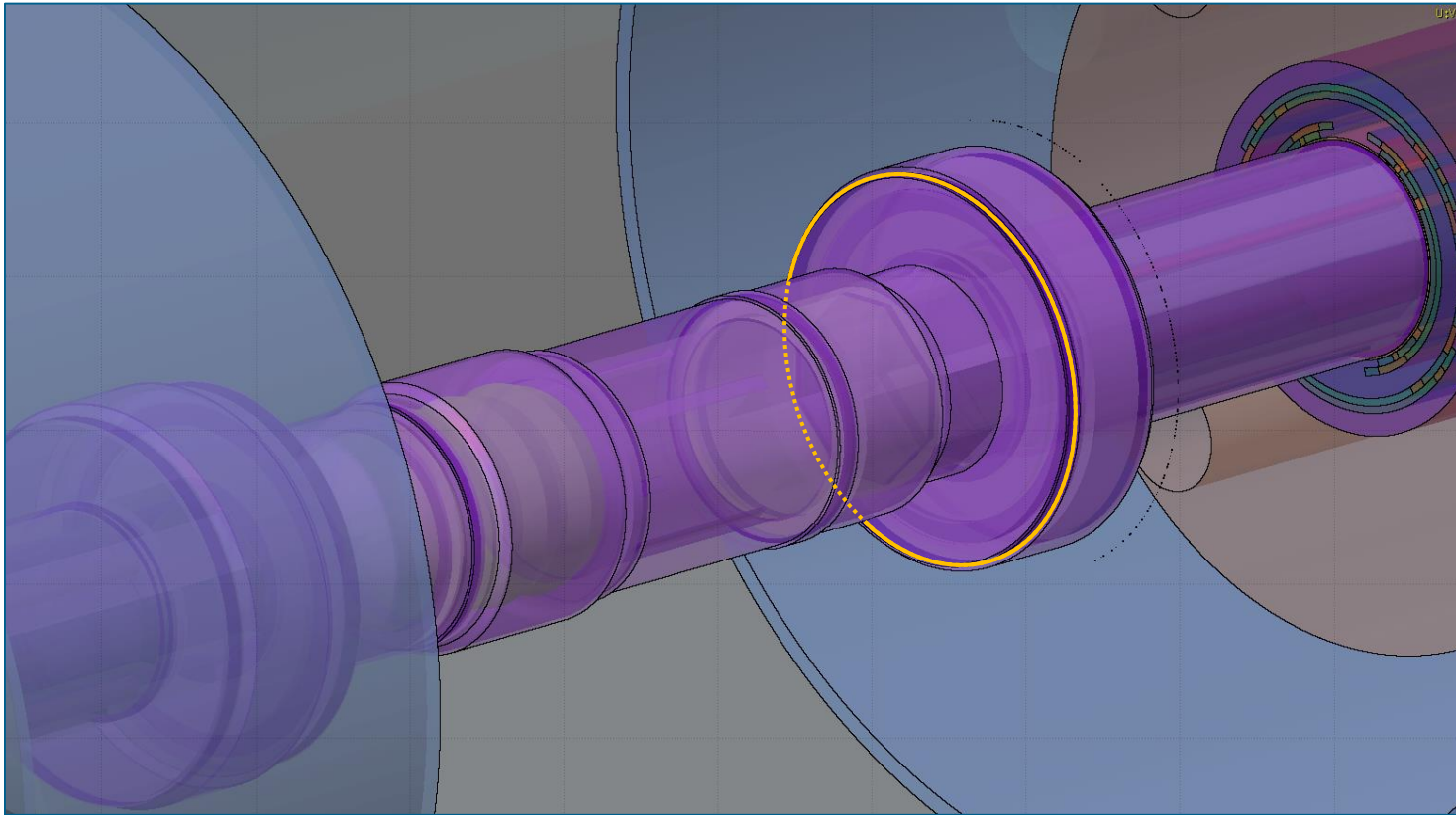

Loss scenario

- Tracking calculations performed by Y. Zou & A. Mereghetti with:
 - 7.0 TeV beam momentum, $\beta^*=15\text{cm}$, $295\mu\text{rad}$ half crossing angle
 - Open TCTs in IR1/2/5/8
 - Aim: to simulate missing protection from TCTs
 - Open TCLA in IR7, TCSG in IR6, TCDQ in IR6
 - Aim: to increase losses in the triplet
 - TCLs open
- Highest losses recorded right of IP5 (incoming beam)

Loss scenario

- Only losses on horizontal plane were considered (dominant contribution)
- In FLUKA, events were sampled from the fitted distributions in s , x , x' , y , y'

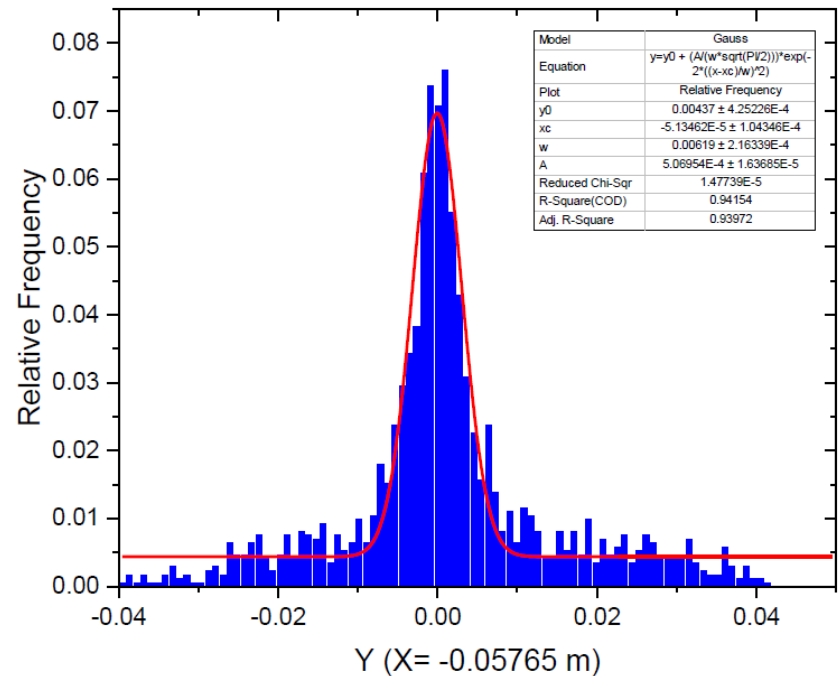
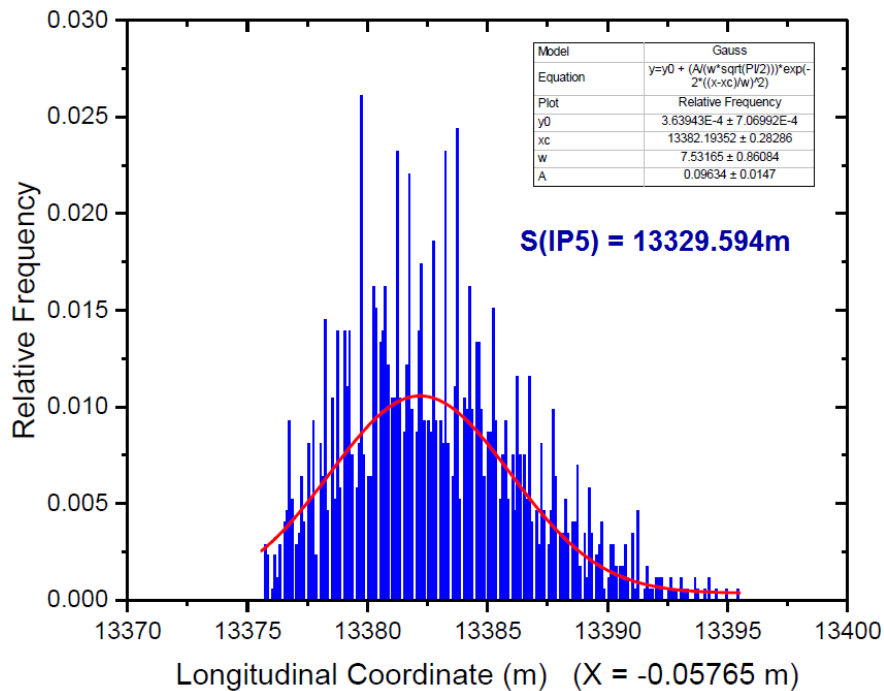

- Losses concentrated between Q3 and Q2B

Triplet-D1: Peak power density profile (Debris, $L=5.0 \times 10^{34} \text{ cm}^{-2} \text{ s}^{-1}$)

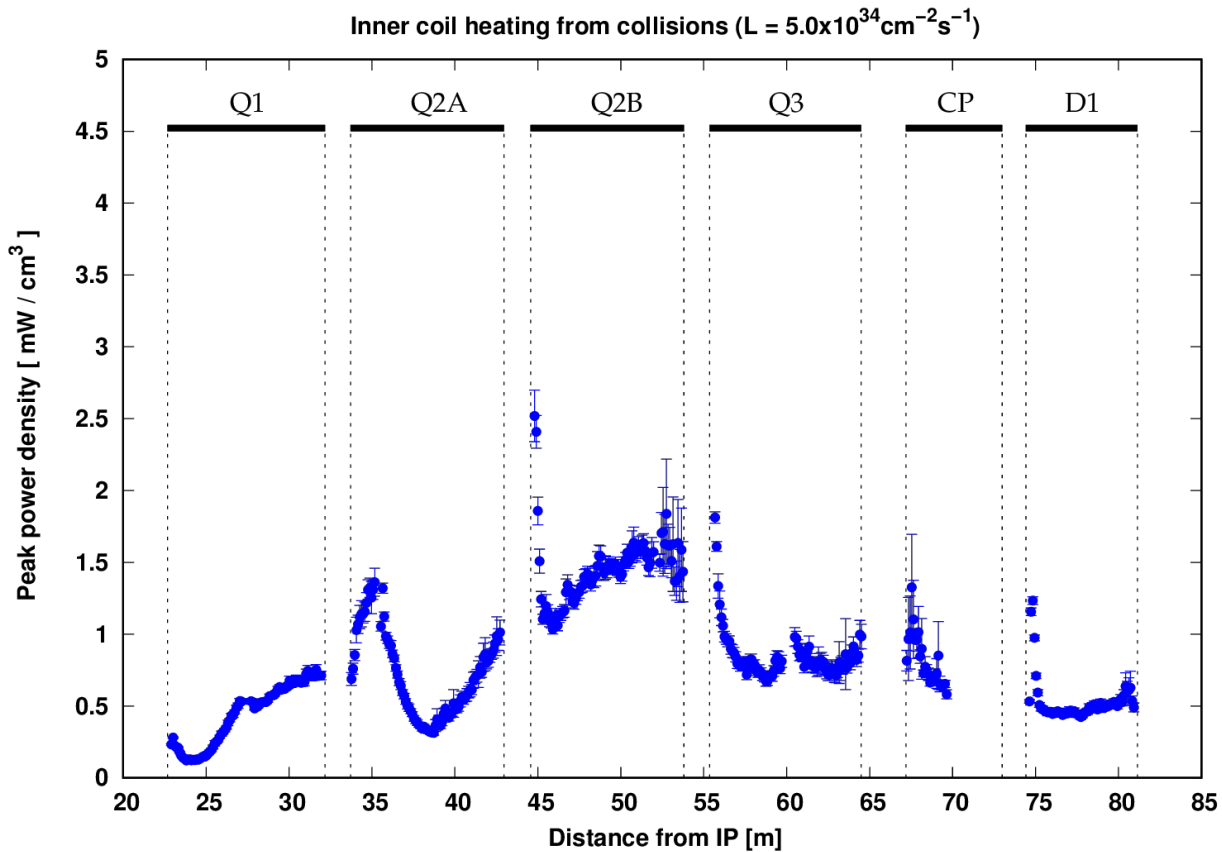

Triplet-D1: Peak power density profile (Losses)

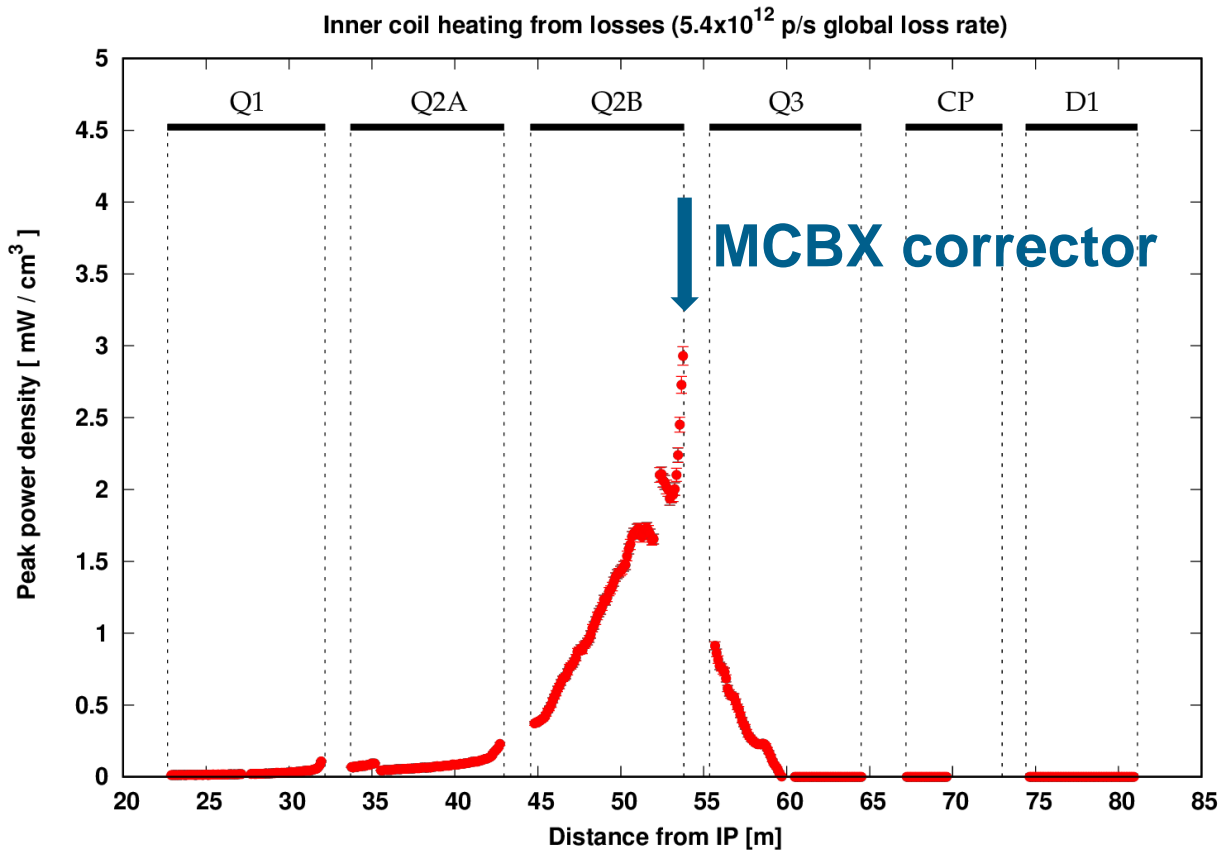

- Normalised in order to reach the 4 mW/cm^3 design limit in the MCBX corrector when added to the debris load

Triplet-D1: Peak power density profile (Debris and losses, 4mW/cm³ maximum value)

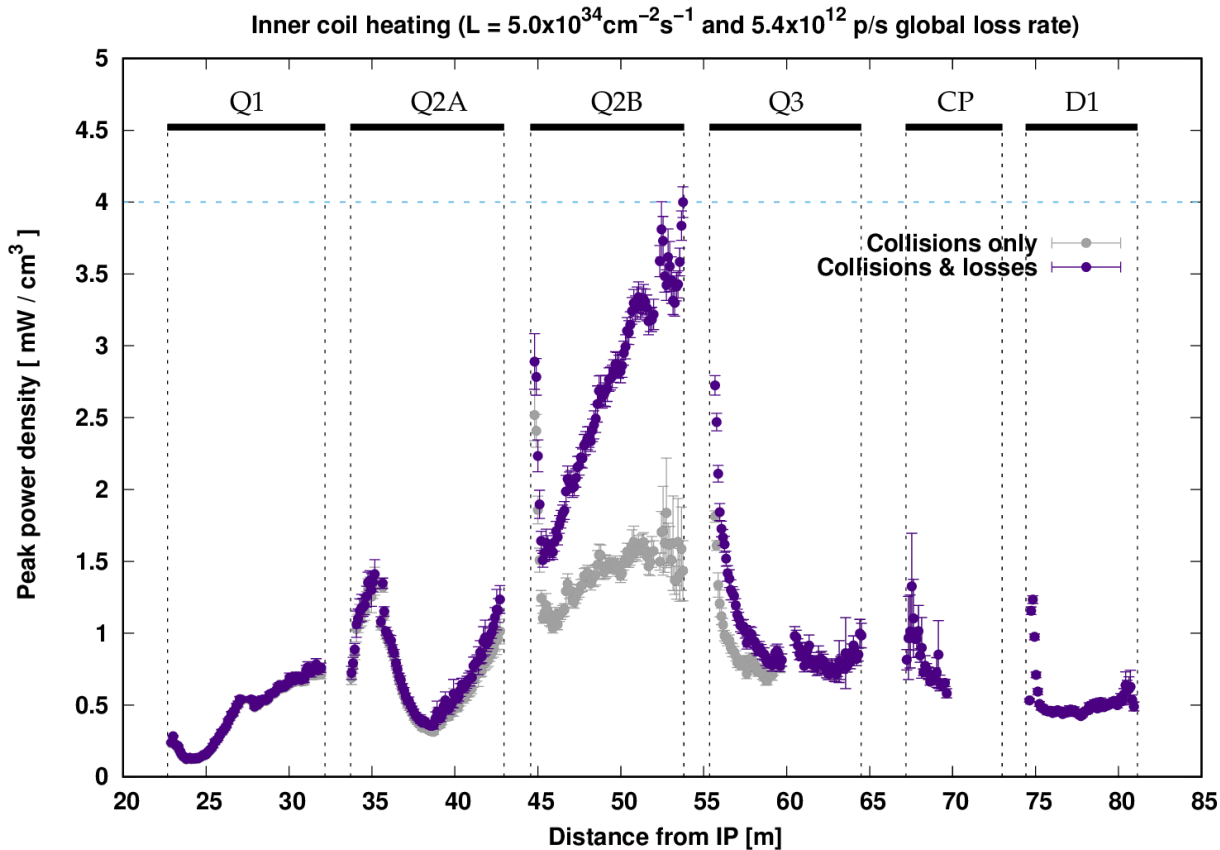

- Corresponds to 3.0×10^8 p/s lost locally $\rightarrow 5.39 \times 10^{12}$ p/s global loss rate
- **Two minutes** of beam life-time, ~6 MW of power lost
- **Such an abnormally low life-time is dumped in the collimation system, hence local detection is not essential**



BLM pattern

Normal BLM response to collision debris

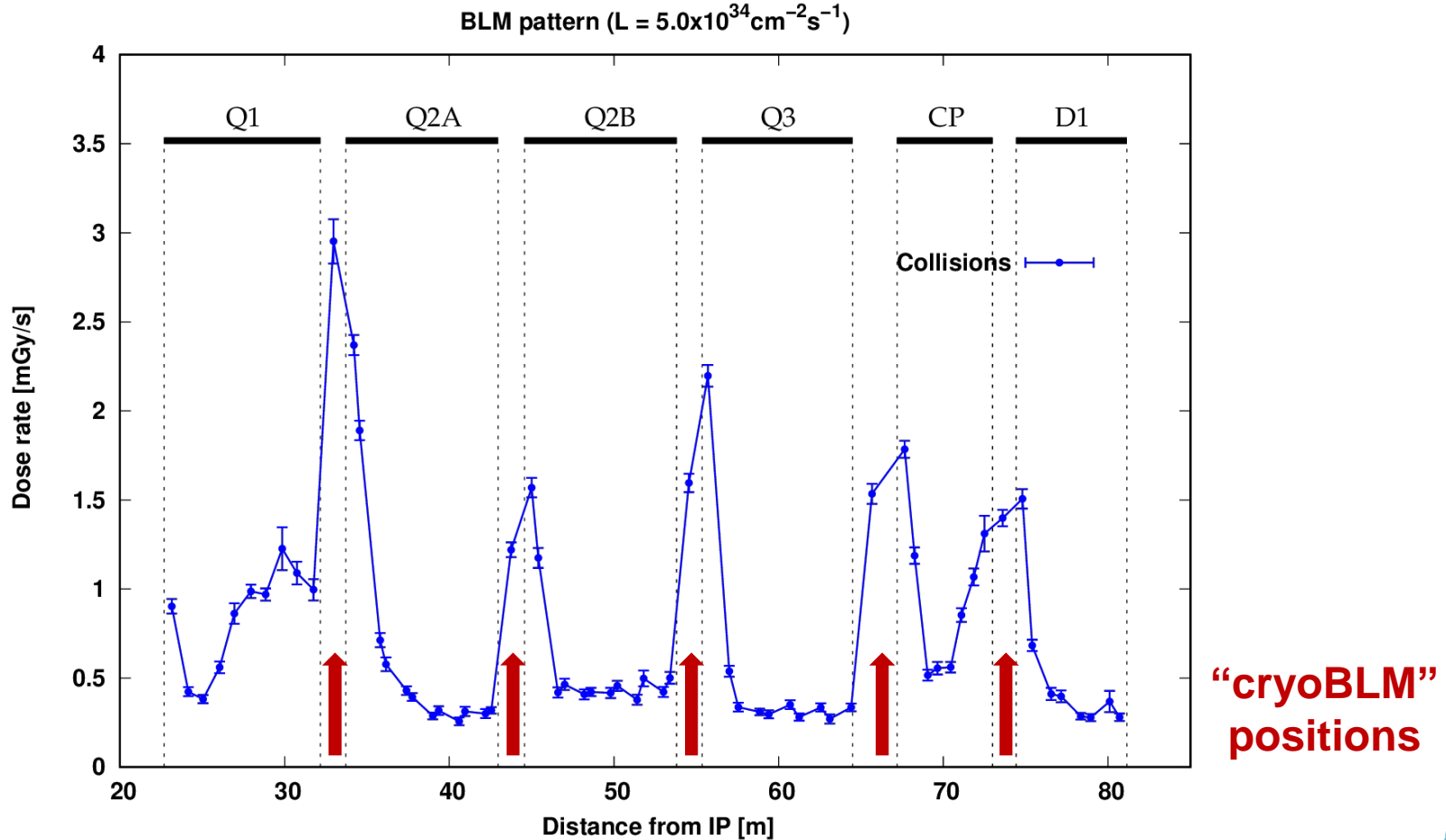

- This high-resolution pattern could guide the optimisation of the BLM placement

Normal BLM response: debris and losses

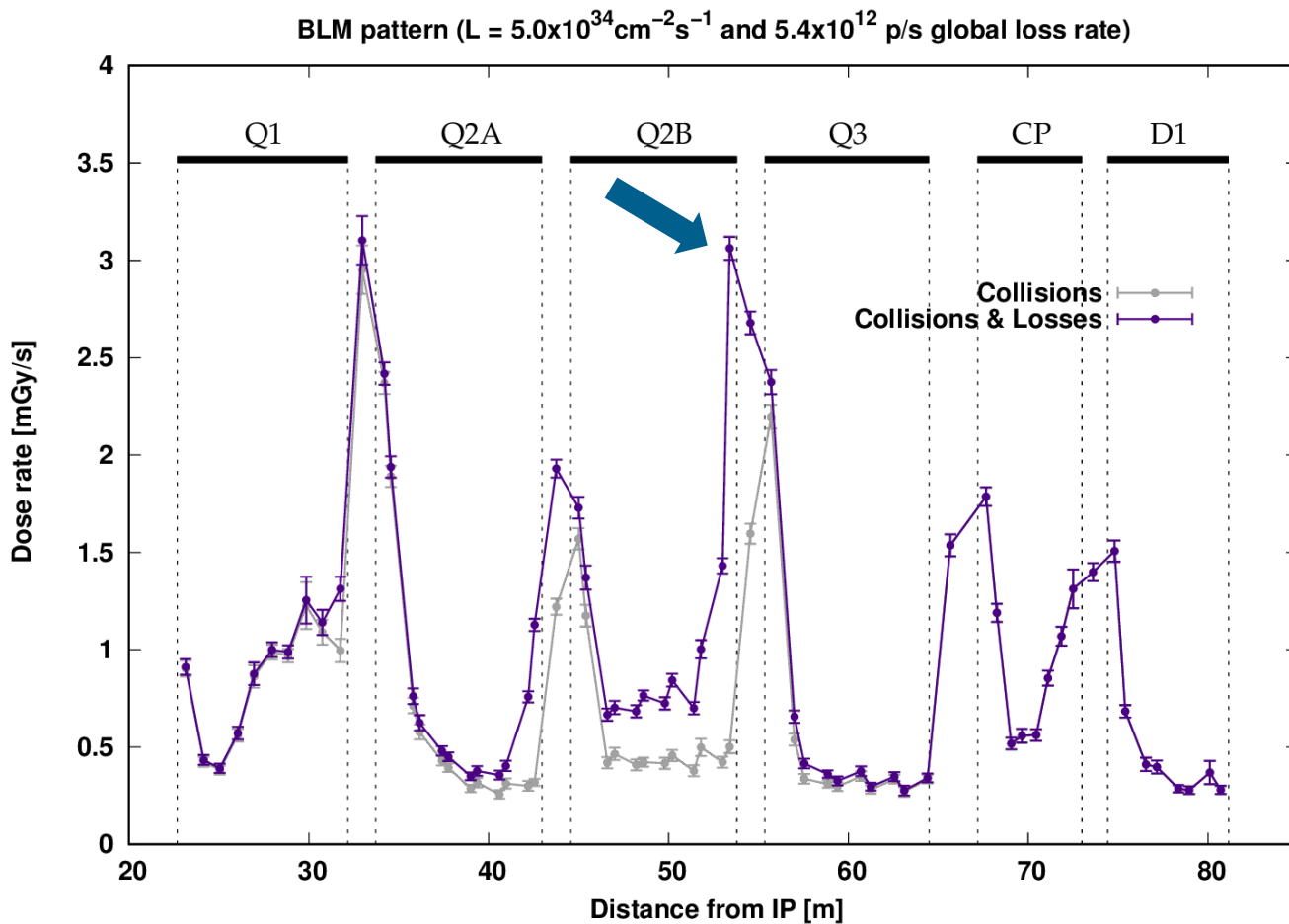

- Highest sensitivity at end of Q2B

“cryoBLM” response: debris vs. losses comparison

- “cryoBLM” values have a strong azimuthal dependence → their exact placement is critical

“cryoBLM” values (debris)

Dist. from IP [m]	Min. [Gy/s]	Max. [Gy/s]
32.97	0.018	0.028
43.75	0.021	0.064
54.55	0.026	0.065
65.67	0.019	0.039
73.6	0.019	0.032

- The maximum values were considered for this study

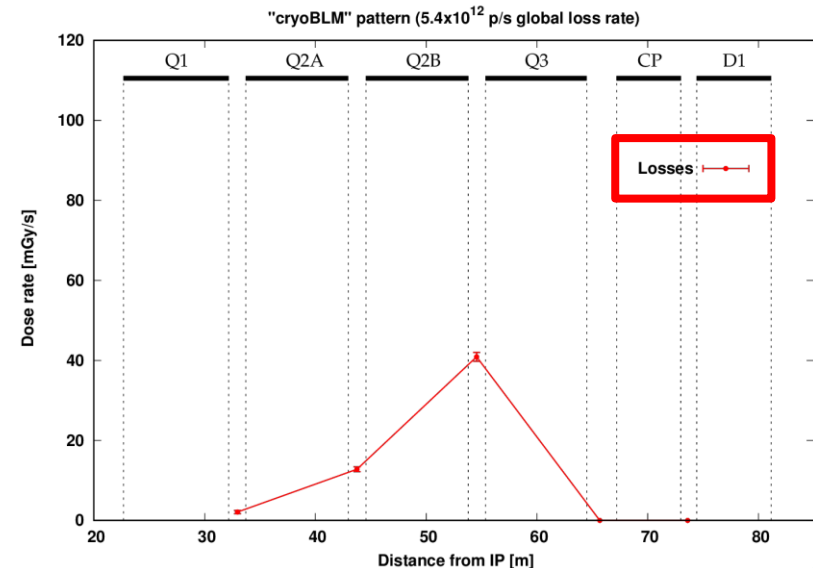
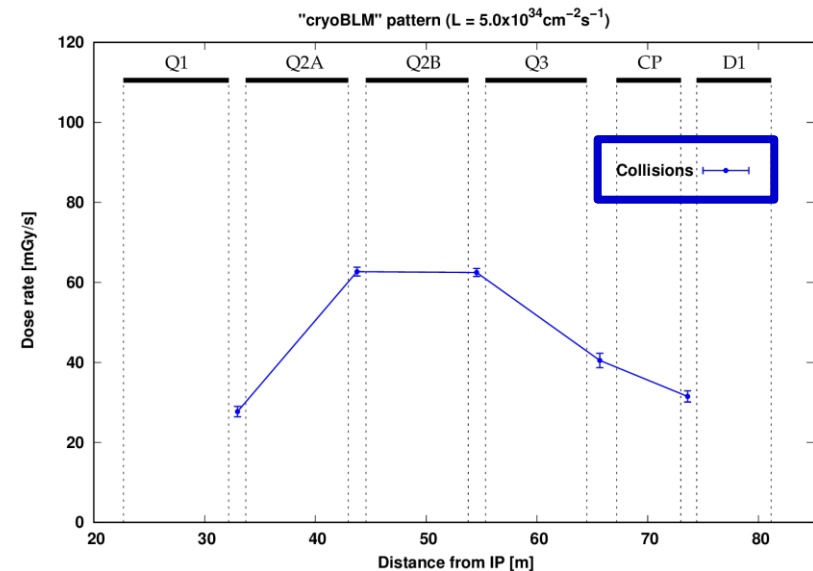

“cryoBLM” response: debris and losses

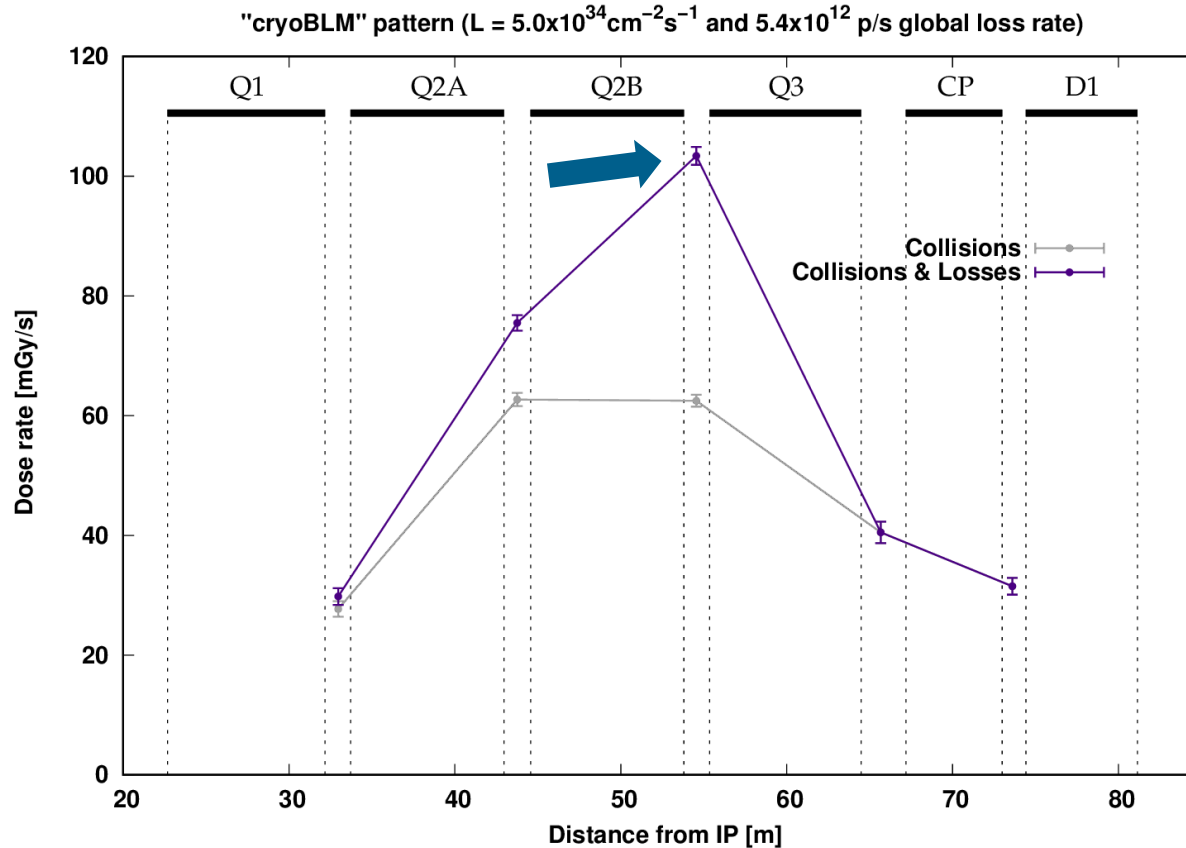

- Highest sensitivity also at end of Q2B
- Not comparable to the normal BLM sensitivity gain due to the less favourable positioning

Summary

- Abnormal losses in the triplet would only represent an operational threat for beam life-times that are sufficiently low to induce a dump in the collimation region by design
- Even for the corresponding extreme loss rate, the presence of cold BLMs does not necessarily increase the detection sensitivity compared with what could be achieved with conventional BLMs, whose placement is less constrained and can be optimised to maximise pattern changes

