



Bare DQW and DQW+HOM cavity tests and future plans, including design updates

Silvia Verdú-Andrés (BNL)
on behalf of HL-LHC DQW crab cavity team

OUTLINE

- **Tests of DQWs in the US:**
 - Performance discussion
 - Future studies and tests
- **Design updates towards LHC-series:** cavity and pickup
 - J. A. Mitchell's talk about HOM filter design updates tomorrow

Bare cavity cold tests

- **Cavity #2: same quench field during CW and pulsed operation** $\sim\sim$ magnetic quench.
- **Improved FE onset for cavity #2 after 18 μm BCP and HPR**, but **still not optimal**: lower Q_0 and higher radiation.
- However, max. B_{peak} **comparable** for both cavities **when uncertainty accounted**.

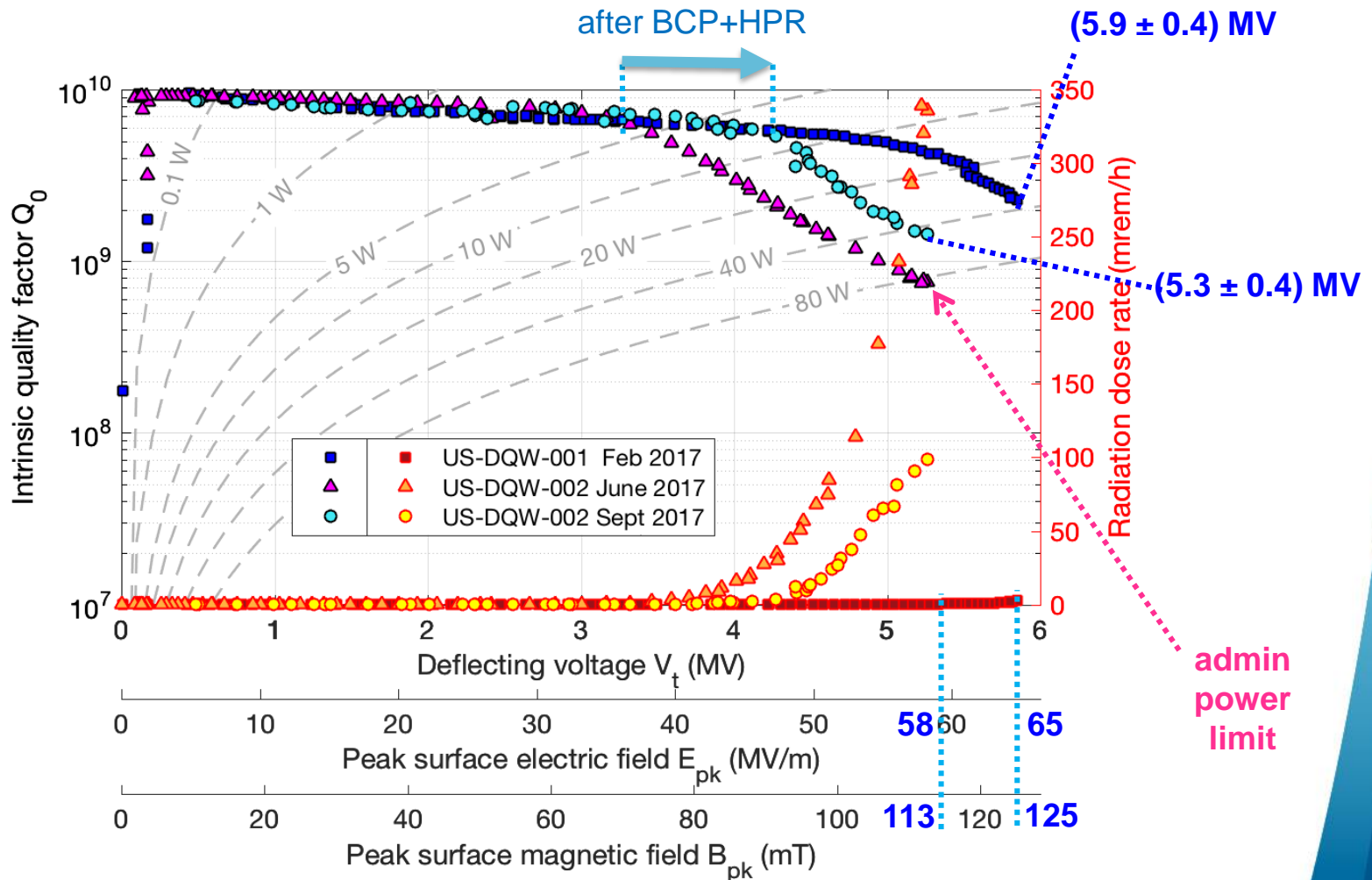

Multipacting bands (example: US-DQW-002 experience)

Cavity waist: (0.1 – 0.5) MV

Hard. Conditioned 1.5h at 10-20 W before first breach through. The cavity **fell into this band after every quench**. Reconditioning took about 30 min.

Beam port and small port blends: (1.6 – 3.0) MV

Soft, but associated with **strong radiation**.

Outer conductor blend: (4.0 – 4.5) MV

Soft. Quenched into this MP band for a few minutes.

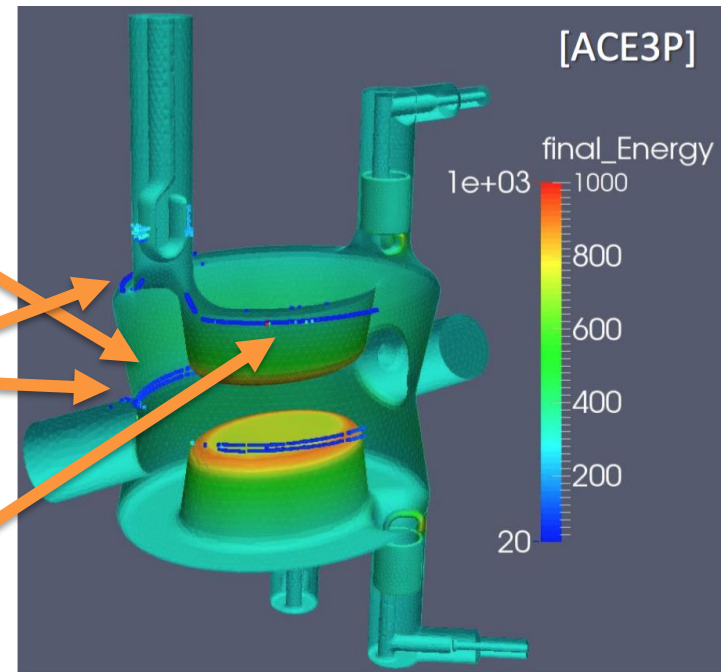

- Used **35 Watts maximum** to go through multipacting.
- **Low-field multipacting conditioning** will be taken care of during **future tests of US DQW cavities** and particularly **during operation in SPS** with overcoupled cavities.

Cavity+HOM cold tests

- The **same HOM filter** tested with cavity #1 and cavity #2.
- **Light BCP** in HOM filter **between tests**: increased quench field from 2.8 to 3.6 MV.
- Quench field level for the two cavity+HOM tests was significantly **lower than for bare cavity** tests. The quench was a sharp one, but with **no significant radiation** increase.
- Quench field level **higher in pulsed mode** $\sim\sim$ thermal quench.

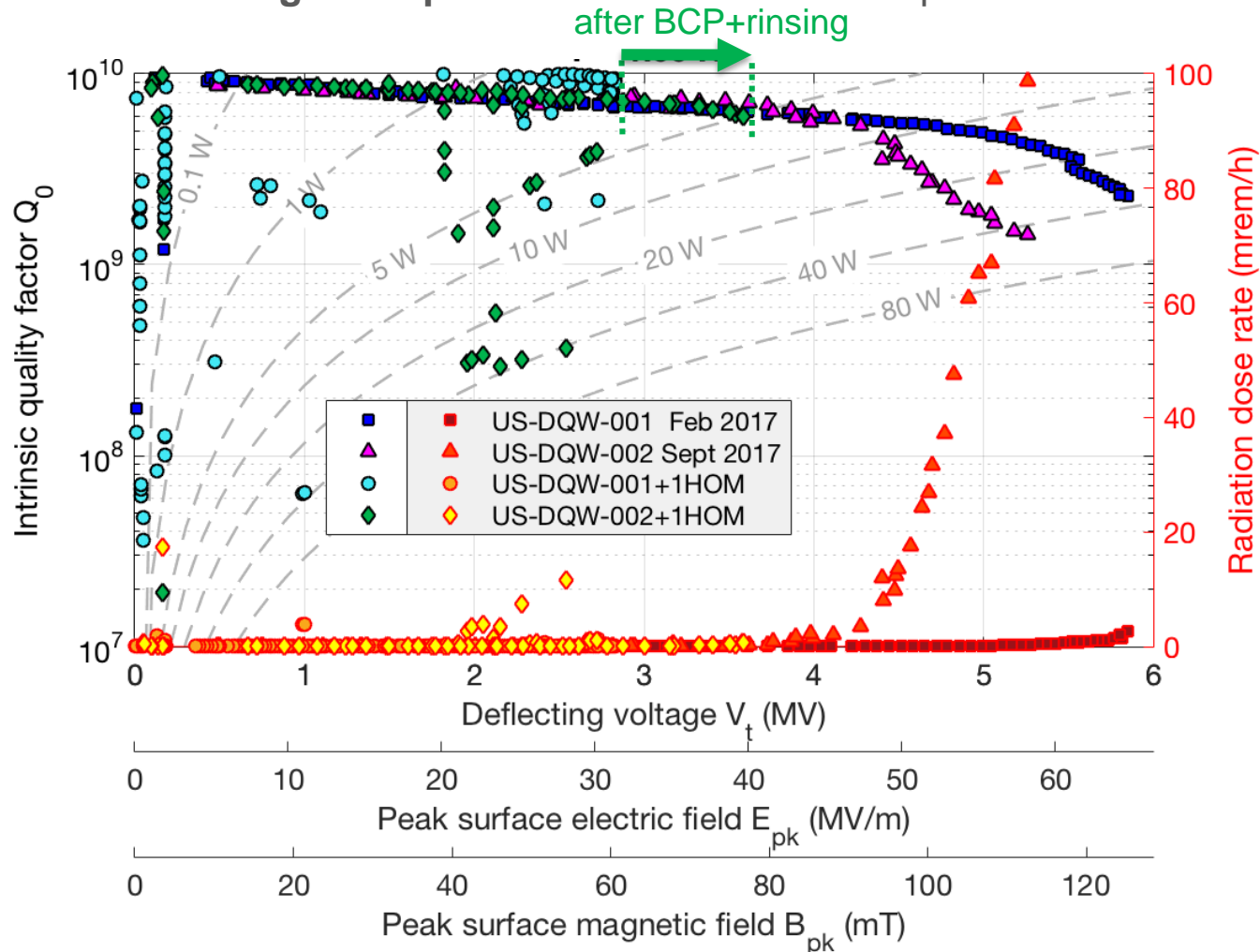

Tests summary

Test US-DQWs		Surfaces	V_T (MV) [CW / pulsed]	V_{FE} (MV)	CERNOX signal
#1	(Feb)	Light BCP+HPR Flanges set # α	5.9 / 5.9	4.1	#A-5 (global max. B_{pk}) [#B-2 (FPC port flange) at 5.5 MV Q-switch event]
#2	(Jun)	Light BCP+HPR Flanges set # α			
#2	(Sep)	Light BCP+HPR Flanges set # α	5.3 / 5.3	2.8	#C-1 (input probe) #A-7 (global max. B_{pk})
#1+HOM	(May)	HOM filter rinsing Flanges set # β	2.8 / 3.4	n/a	#B-5 (FPC port flange) #D-7 (HOM filter) #E-8 (HOM filter)
#2+HOM	(Oct)	Light BPC+rinsing Flanges set # α	3.6 / 4.1	n/a	#F-4 (HOM port base) #D-7 (HOM filter) #E-8 (HOM filter)

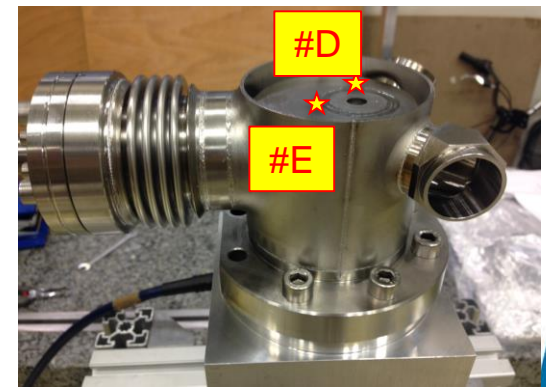
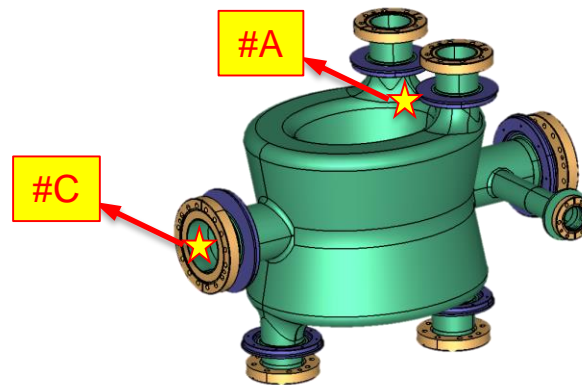
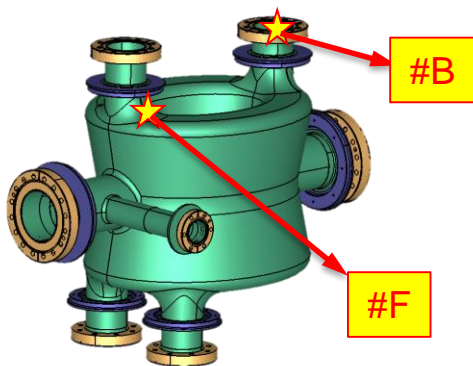

Focus on understanding early quench

MOTIVATION

- **SPS test voltage limitation** comes from **large heat load** in CERN SPS DQW cavities, but **cavity+HOM quench level will not be reached**.
- But we should **ensure maximum voltage operation for LHC**:
 - Esp. important when HL-LHC baseline only foresees 2 cavities/beam/IP/side.
 - If 5 MV are reached, then 2 cavities provide 10 MV/beam/side for full crabbing.

HOM FILTER DESIGN - recap

- Enough cooling under normal circumstances: $\Delta T = 0.24$ K at $V_t = 3.6$ MV (10 n Ω Nb)
- LC filter: wide notch, large 400 MHz rejection (confirmed with S_{21} measured at 2 K)

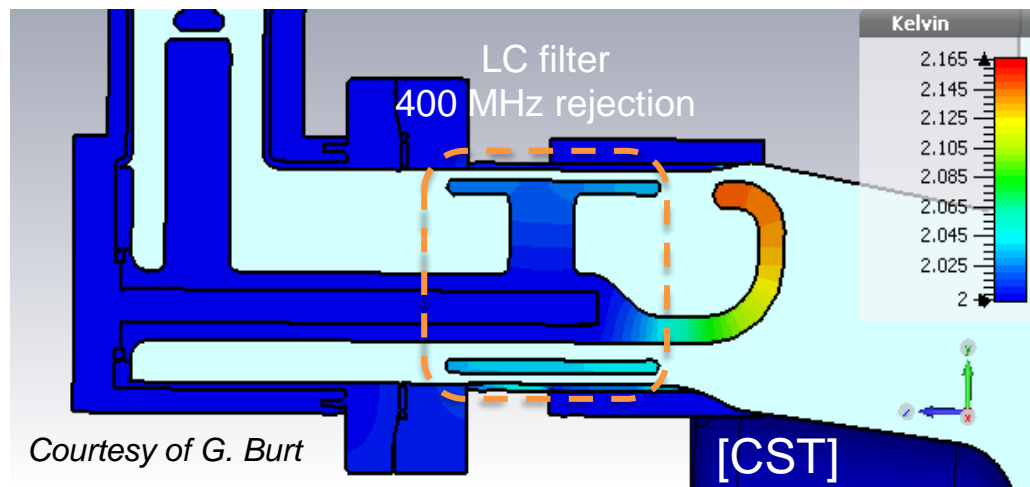

Focus on understanding early quench

POSSIBLE EXPLANATION

- Thermosensor signals indicate **interrupted thermal path** → **mechanism** connects two ΔT sites (HOM filter and port blend) **through vacuum**.

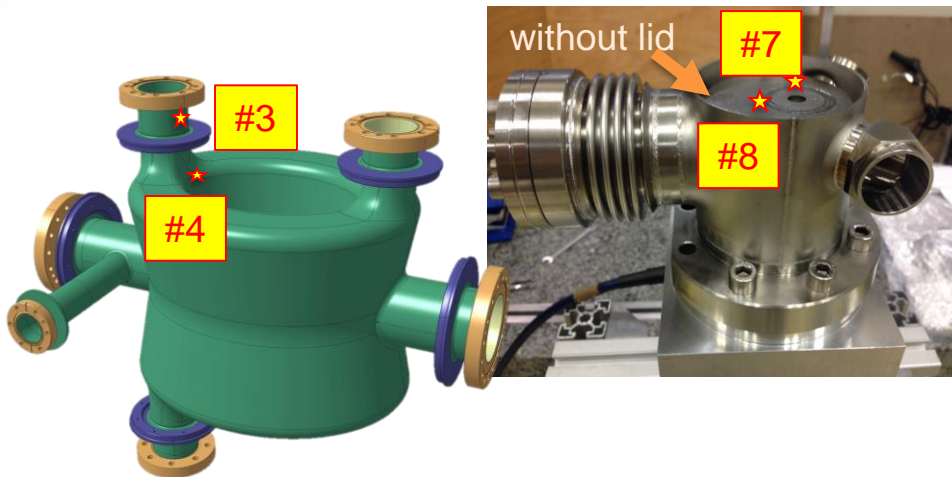

- Likely an **electrical arc**; may appear from:
a) massive **MP**; or b) plasma generated in narrow HOM filter region due to **incident FE currents**.

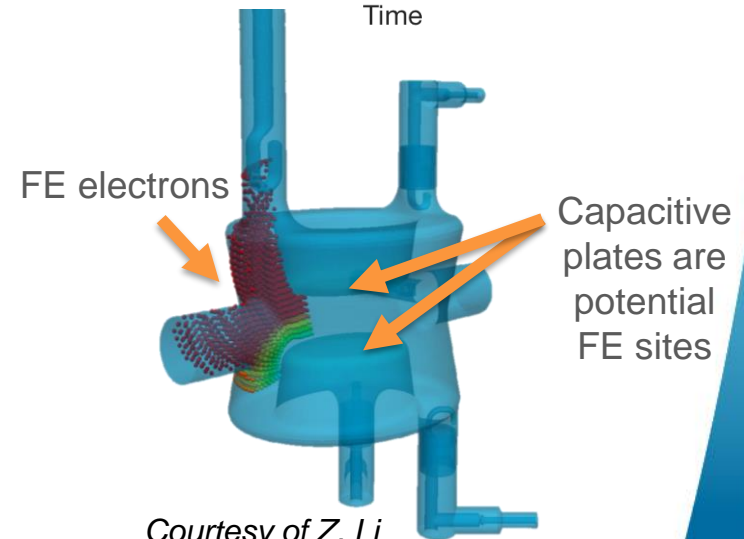
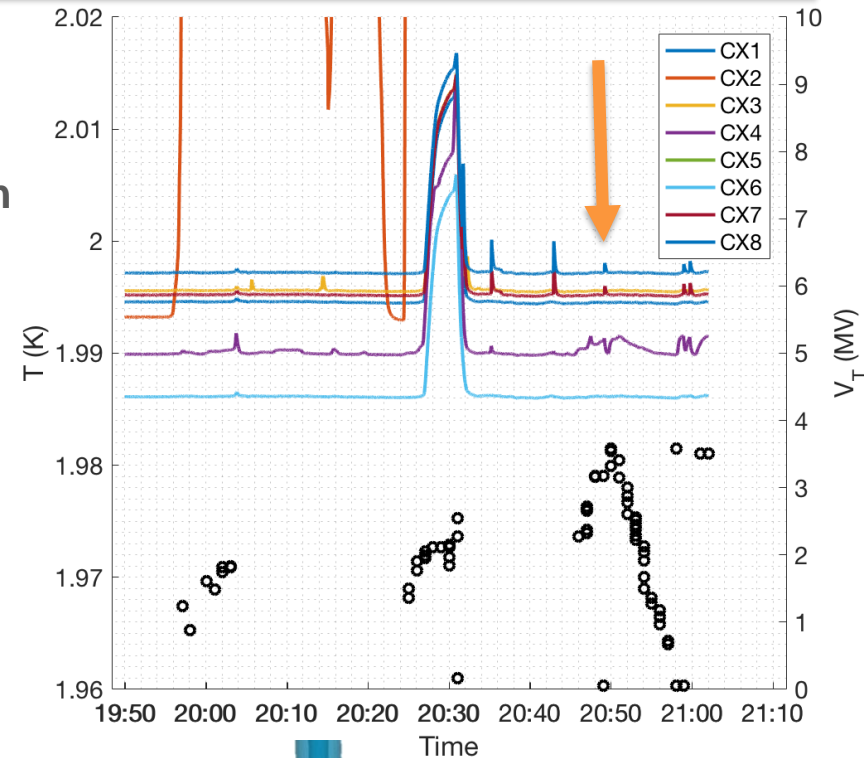

Courtesy of Z. Li

Focus on understanding early quench

PLANNED STUDIES

- **Energy deposition** on HOM filter by **FE current** electrons (Z. Li, SLAC).
- Detailed **MP studies on HOM filter** region around **quench field level**.
- **Thermal gradient** calculation in HOM filter for **niobium Rs > 10 nOhm**.

NEXT TESTS

- **Improved cavity+HOM performance** from May to Oct **associated to 20um BCP?**
 - perform 50 um BCP + 120°C bake to complete standard surface treatment
- Does a **lower Hpk** in filter help reaching higher field level?
 - use spacer
- Is **FE current responsible** of quench?
 - electropolishing (reduced surface roughness) or pure coaxial cavity

Some notes

- Use the same cavity (US-DQW-002)
- Diagnostics are key:
 - thermosensors
 - transmitted RF signal through HOM filter: DC current (FE), frequency components (MP)
 - additional radiation monitors
 - high repetition rate acquisition of transmitted RF signal (resolve MP and FE signatures)

From SPS to LHC: modifications

① Make length of both beam ports equal

MOTIVATION

Losses in SS flanges require Nb-coated flanges for cold tests (costly, timely, peeling may compromise performance: Q-switch, contamination)

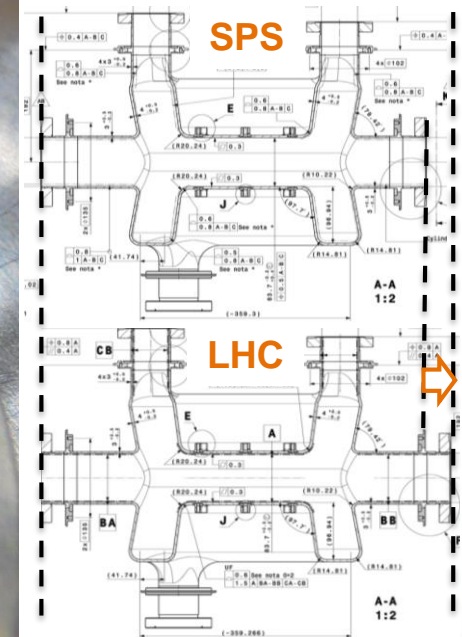
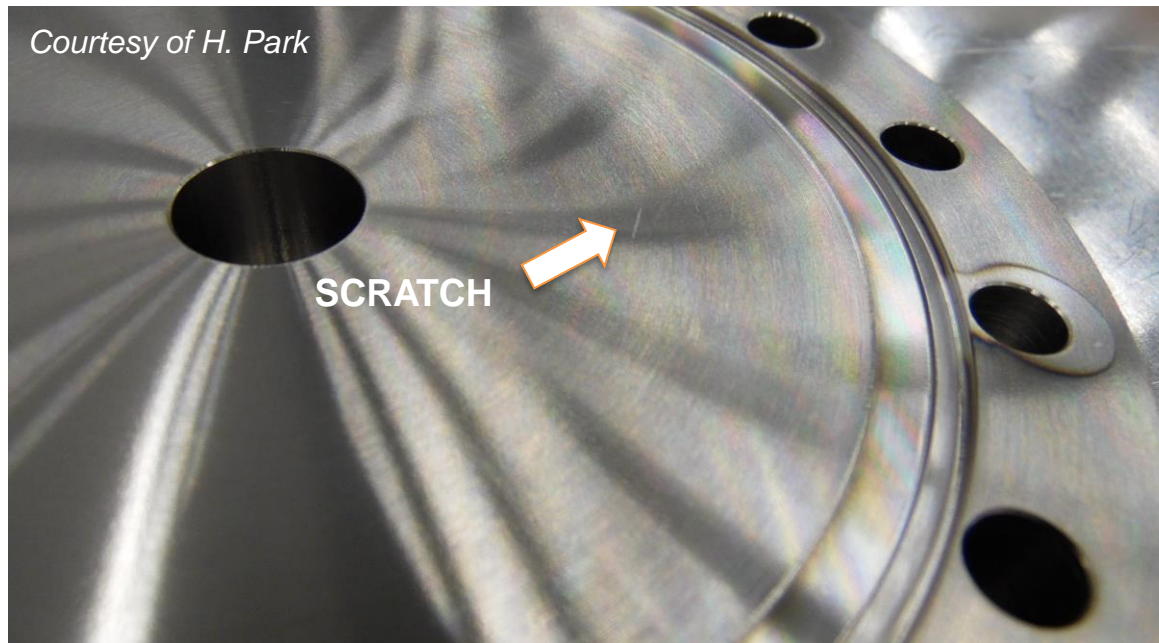

PROPOSAL

Make the length of both beam ports equal (other ports cannot be changed)

STATUS

Implemented – drawing already updated (LHCACFCA0367)

From SPS to LHC: modifications



② Simplify pickup design and further reduce impedances

MOTIVATION

- The current pickup (SPS version) is **dual purpose**:
 - hook** to extract enough **400 MHz** mode for **monitoring**
 - “umbrella”** to couple to **1754 MHz** mode for **damping**

Mode 1754 MHz	Q_{ext}	Z_H (Ohm/m)
No “umbrella”	4.2e6	3.4e8
With “umbrella”	1.0e4	2.7e6

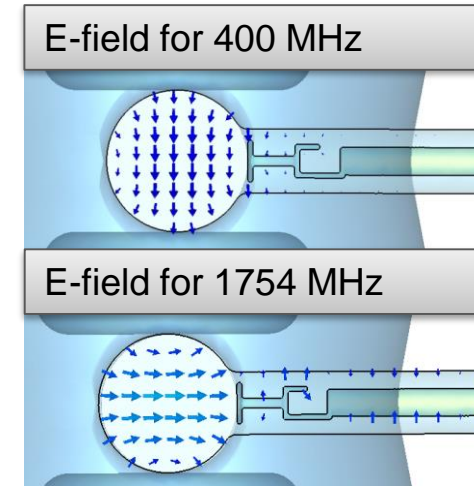

- Pickup tip exposed to large currents, so fabricated in Nb to reduce heat load; the rest is made of copper, for better heat extraction → **brazing is complicated**.
- Reducing impedance** of some modes (esp. **1920 MHz**) is always **encouraged**:

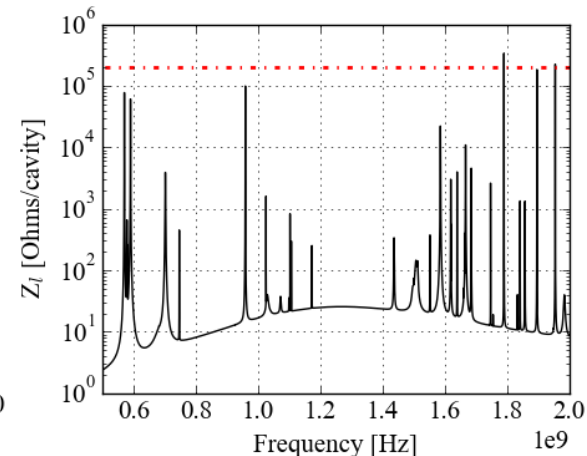
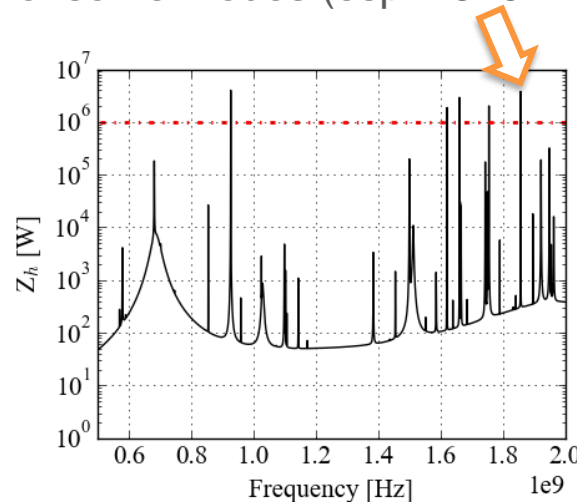
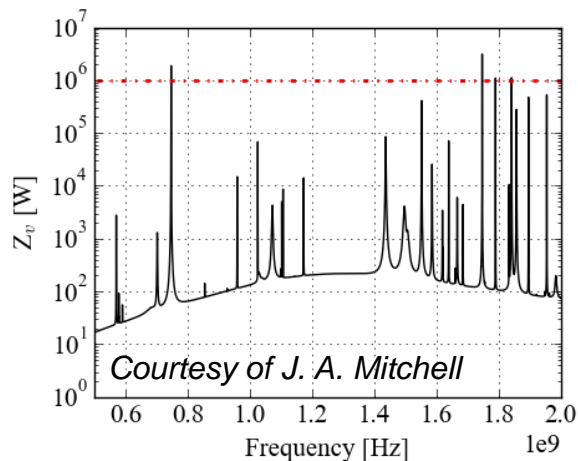

From SPS to LHC: modifications

② Simplify pickup design and further reduce impedances

MULTIPLE ALTERNATIVES EVALUATED

a) *Different pickup antennas*

- not enough coupling to 1754 MHz and/or
- not enough / too much extraction of 400 MHz and/or
- complicated manufacturing

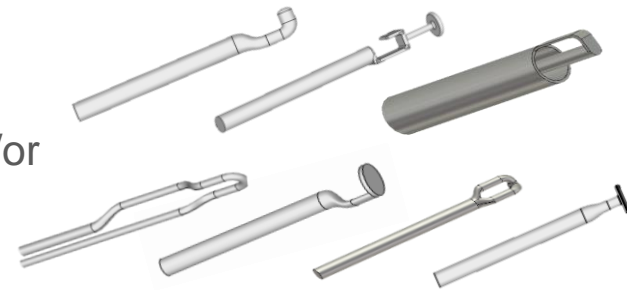

b) *Vertical pickup tube*

- difficult manufacturing (esp. beam pipe – cavity weld)

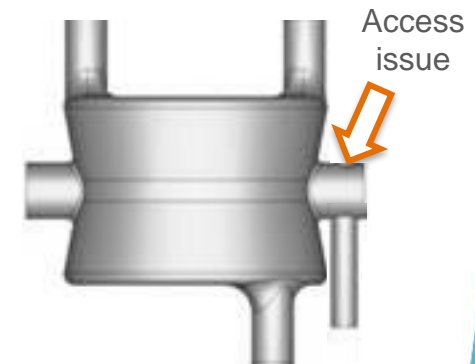

c) *Change port location (45 deg → 60-deg)*

- not significant improvement of coupling to 1754 MHz

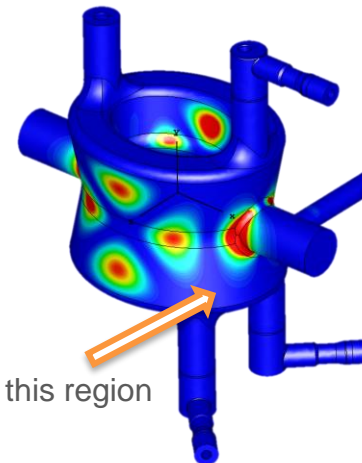
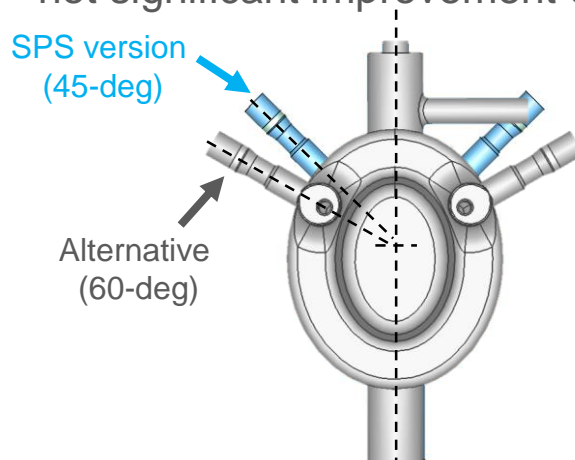

Low field in this region

From SPS to LHC: modifications

② Simplify pickup design and further reduce impedances

MULTIPLE ALTERNATIVES EVALUATED

d) Change beam port section

The simplest to implement

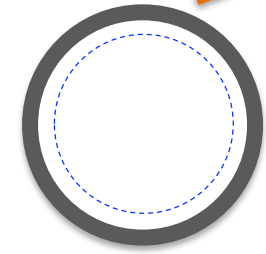
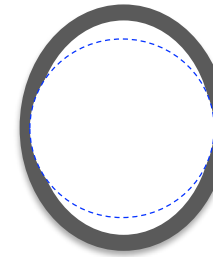
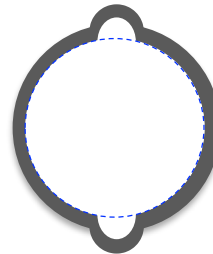
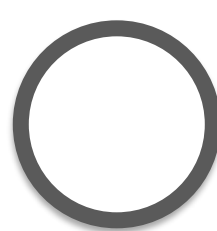

SPS version

Fluted

Elliptical

Enlarged round

Dimensions (mm)	(R = 42)	(R = 42, p = 14)	(R _m = 42, R _M = 47)	(R = 47)
TE ₁₁ -H cutoff (GHz)	2.09	1.77	1.87	1.87
Z _{H, 1754} (Ohm/m)	8.2e5	1.6e4	1.3e5	9.8e4
Z _{H, 1920} (Ohm/m)	2.3e6	5.0e4	4.5e5	1.4e6

with "umbrella"

improved 1754 and 1920 MHz impedance w/o "umbrella"

- **400 MHz mode detuning** by -0.38 MHz (enlarged) and -0.09 MHz (elliptical) easily compensated with "alternative" tuning ($\Delta x < 0.32$ mm)
- **HOMs detuning < 5 MHz** → no significant power increase (see Mitchell's talk)
- Extracting **through beam ports** requires **damping** (in SS bellow or via BPM)

From SPS to LHC: modifications

③ HOM filter

MOTIVATION

- Reduce **sensitivity of 960 MHz transmission** with **detuning**.
- Simplify **fabrication**.

PROPOSAL

New HOM filter design (J. A. Mitchell's talk tomorrow):

- Detuning of 960 MHz is no anymore leading to large power spike.
- D-shaped capacitive ring to ease manufacturing.

SUMMARY (I)

Still learning from the two US SPS DQW cavities...

- **Excellent** performance of **bare cavities** beyond nominal (up to 5.9 MV).
 - Large peak fields reached (~ 30 MV/m TESLA-type cavity)
 - FE onset at $V_t = 4.1$ MV (above nominal deflecting voltage)
 - Pretty low surface resistance (9 nOhm)
- **Cavity+HOM** performance limited by **early, fast quench** (max. V_t of 3.6 MV).
- Understanding the **mechanism** behind **early quench** is essential for future LHC:
 - More comprehensive **studies**: *thermal gradient dependence on R_S , multipacting, energy deposition of field-emission electrons, etc.*
 - More **testing**: *application of standard bulk BCP+120°C bake to HOM filter, peak field reduction in HOM filter (spacer), additional diagnostics, electropolishing, etc.*

... and more to come

- See A. Ratti's talk on **more plans for US SPS DQW cavities**: *field distribution, tuning, multipacting conditioning, etc.*

SUMMARY (II)

Experience with SPS cavities translates into improved design for LHC

- Both **beam ports** now have **equal length** to **avoid Nb-coated flanges**.
- Proposed **beam pipe enlargement** allows **simplifying pickup** and **reducing impedance of 1920 MHz** transverse mode. Need to **check** appropriate **damping**.
- Promising **new HOM filter design** for enhanced **performance and fabrication**.

From LARP to HL-LHC AUP: *BNL contribution*

From Leonardo Ristori (FNAL):

FY18 EFFORT (SOWs being finalized)

BNL	ODU	SLAC
Interfaces in SM18, SPS and LHC	Warm measurements of electromagnetic and mechanical properties of the RFD cavity	Produce a RFD cavity design addressing the 760 MHz HOM issue
Lessons learned from DQW production	Elastic and plastic tuning sensitivity, including behavior of fundamental and higher-order modes	Calculate the full HOM impedance spectrum up to 2 GHz
Preliminary MIP for RFD pre-series production	Warm measurement of the electromagnetic properties of the HOM couplers	Design HOM coupler RF windows (feed through)
	Oversee Design of dressed cavity (bare cavity, magnetic shields and helium tank)	Analyze cavity and coupler tolerance for engineering design;
Contribute the relevant sections of the Preliminary Design Report	Contribute the relevant sections of the Preliminary Design Report	Contribute the relevant sections of the Preliminary Design Report



Thanks for your attention

Acknowledgements

The HL-LHC DQW crab cavity team, Jlab and Niowave Inc..

Funding agencies

Work supported by US DOE through Brookhaven Science Associates LLC under contract No. DE-AC02-98CH10886 and the US LHC Accelerator Research Program (LARP) and by the European Union HL-LHC Project. This research used resources of the National Energy Research Scientific Computing Center, which is supported by US DOE under contract No. DE-AC02-05CH11231.



Back-up

Outline

- **Proof-of-Principle (PoP) cavity:** design and performance
- **From PoP to SPS-series:** improvements
- **The SPS-series cavities:** performance
- **Towards LHC-series:** possible improvements

Bare cavity cold tests: thermosensor location

- US-DQW-001 (Feb)
- US-DQW-002 (Jun)

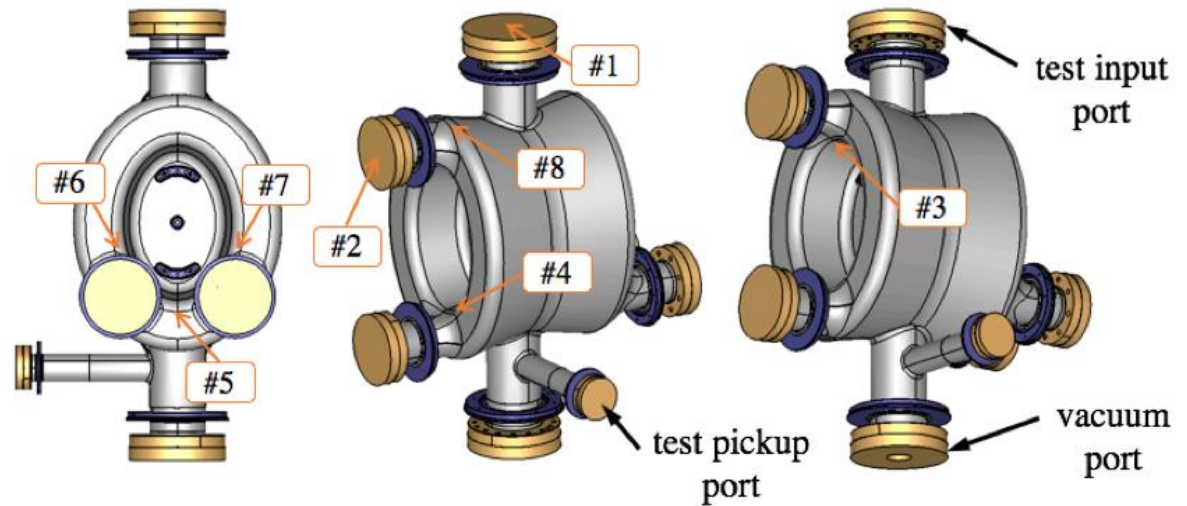

- US-DQW-002 (Sep)

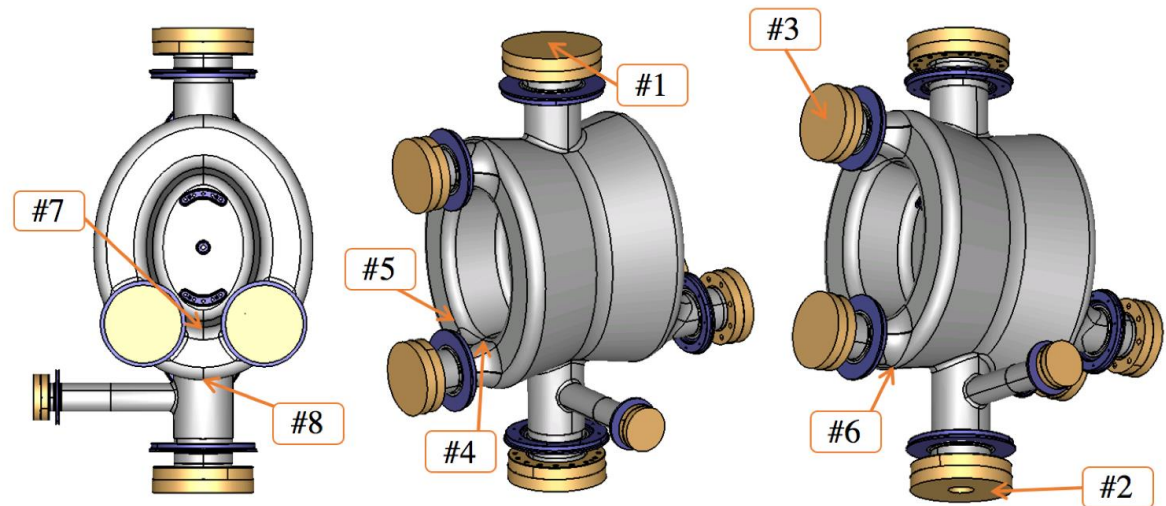

Bare cavity cold tests: thermosensor signal

- Thermosensor location changed from test in June 2017 to test in September 2017.
- All are CERNOX® thermosensors, as in previous tests of DQWs conducted in JLab.
- Only CX #1 and CX #7 show peaks. The other thermosensors were: a) in region where temperature did not increase; or b) not attached to cavity.
- After quench, high temperature in #1 (input probe flange) and #7 (maximum peak B-field) for $V_t > 4.3$ MV while field is being reduced in cavity.
- CX #1 reaches higher temperature and stays hot for a longer time after quench than CX #7. The thermal path from bath to Nb coating in short beam port flange is longer than at point #7. Thus, longer time is also expected for the film to become SC again after quench.

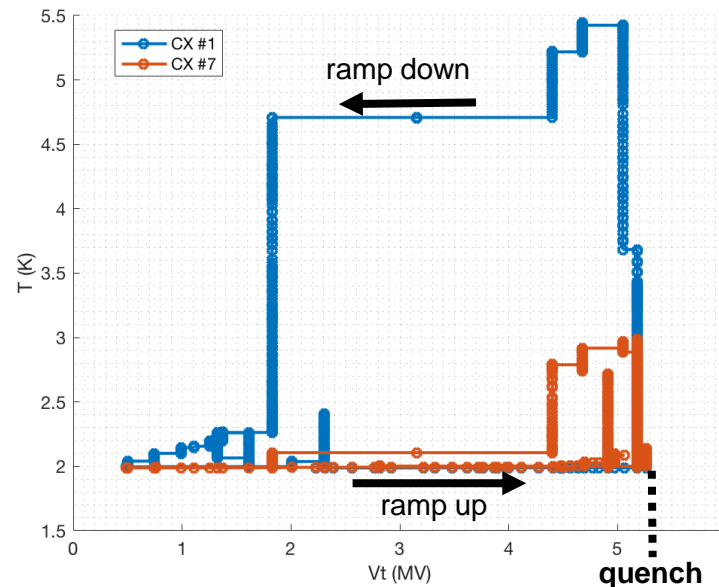

PoP DQW crab cavity: design

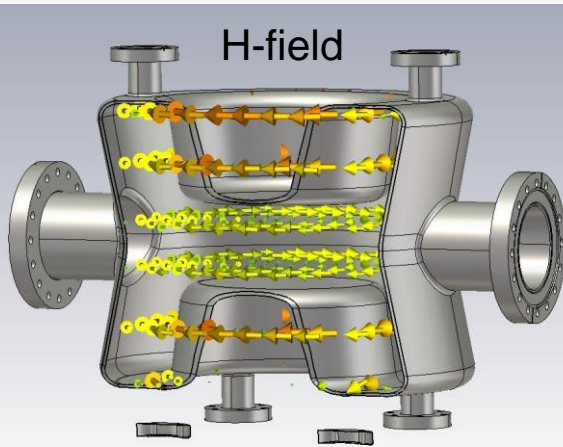
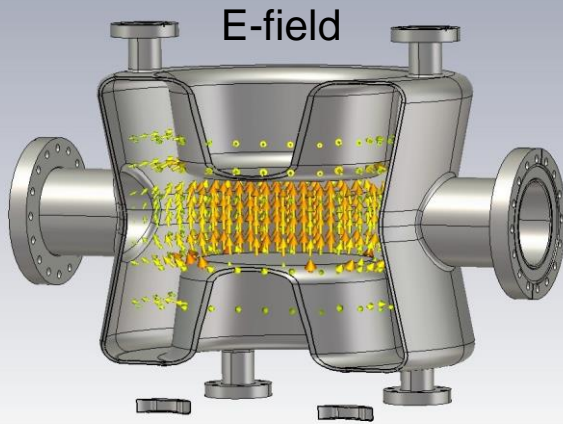

fundamental mode

- **Compact deflecting cavity at 400 MHz** (fundamental mode).
- Crabbing kick when bunch is at cavity center and E-field is zero.
- **First HOM is well away from fundamental mode ~ 579 MHz.**
- Transition from QW to DQW to reduce residual acceleration (still some due to port asymmetry)

Frequency	400	MHz
First HOM	579	MHz
E_{peak}/V_t	13.3	1/m
B_{peak}/V_t	23.9*	mT/MV
V_{acc}/V_t	0.5	kV/MV
U/V_t^2	1.1	J/(MV) ²
R_t/Q	400	Ohm
G	85	Ohm

* maximum B_{peak} at port blending

PoP DQW crab cavity: performance



PoP DQW cavity fabricated at Niowave Inc. with stiffening frame

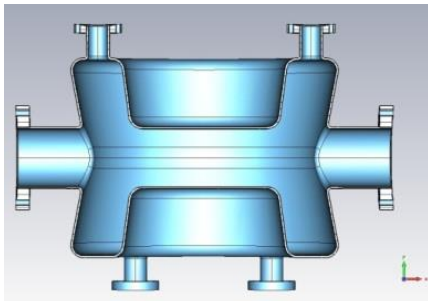

Validation of nominal deflecting voltage (Nov 2013)

- Surface treatment at ANL, coated flanges from CERN, RF tested at BNL
- Reached **4.5 MV kick in pulsed mode**, limited by quench.
- Temperature increase on pickup port blending area and, during the CW operation, also on beam pipe flanges.

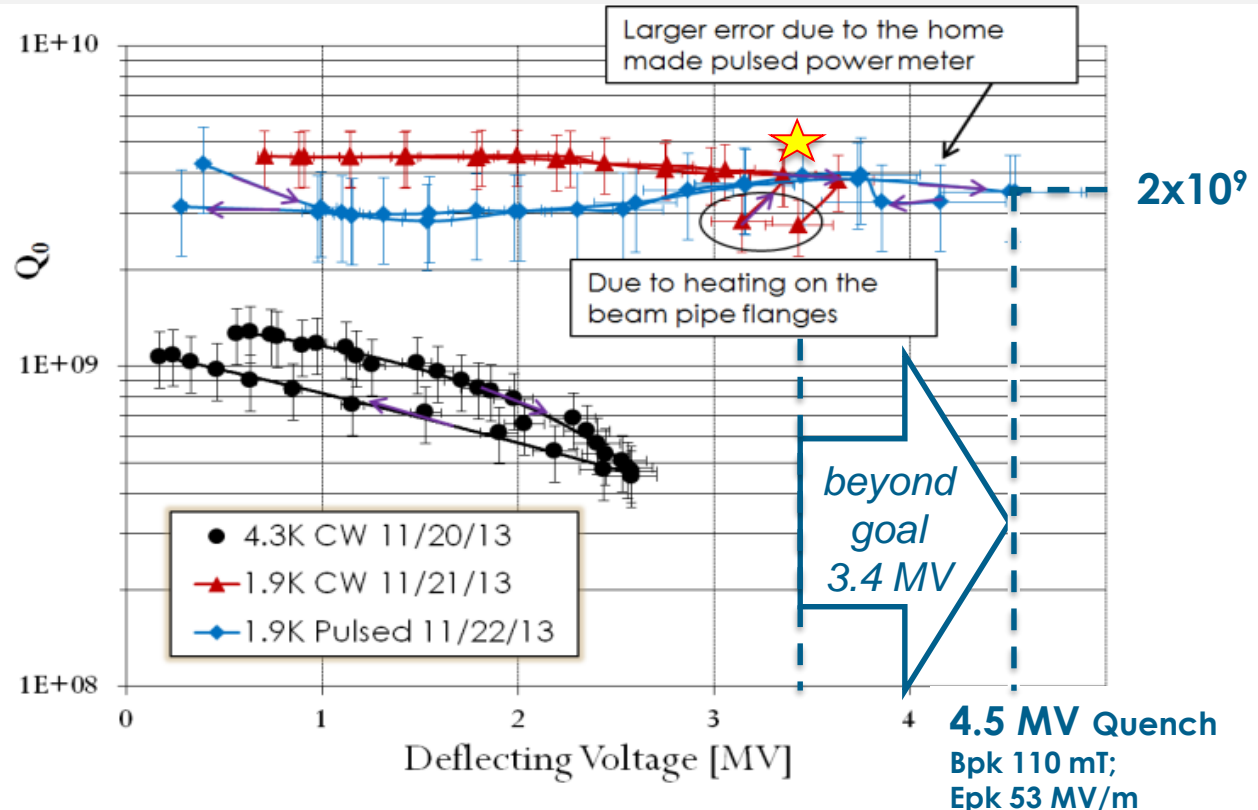

From PoP to SPS-series: improvements

E-field

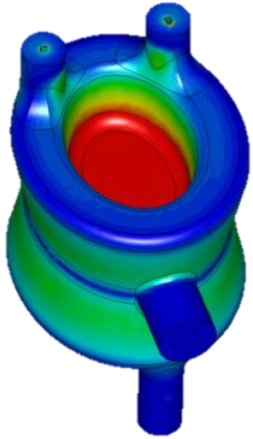

H-field

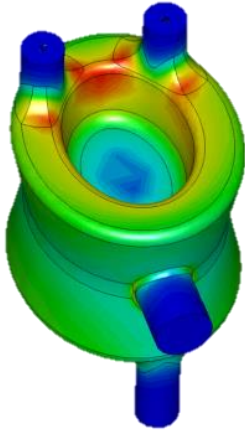

fundamental mode

- ① **Realistic port size** for FPC and minimum number of HOM filters
- ② **Reduction of B_{peak}/V_t** by enlarging port blending

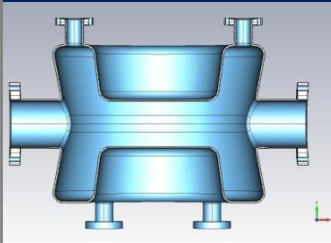
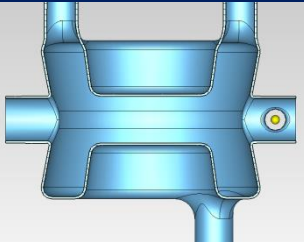
	PoP DQW	SPS DQW
		
B_{peak} (mT)	80	72

$B_{\text{peak}} \sim 110$ mT at PoP DQW quench \rightarrow SPS DQW **expected to reach $V_t \sim 5.1$ MV**

- ③ **Clearance with second beam pipe** (for horizontal and vertical kick configuration)

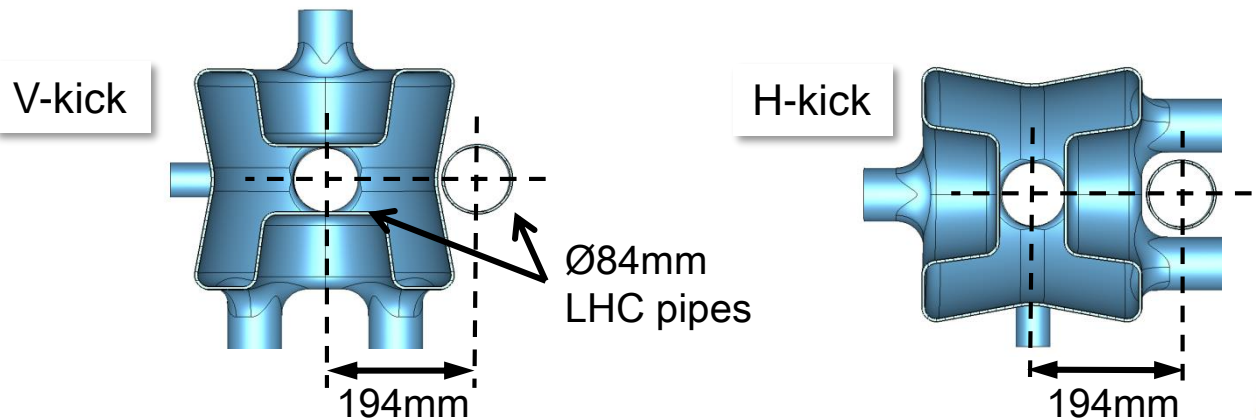

SPS DQW crab cavity: design

- RF design provided by BNL with CST, values verified by SLAC with ACE3P
- Mechanical model generated by CERN

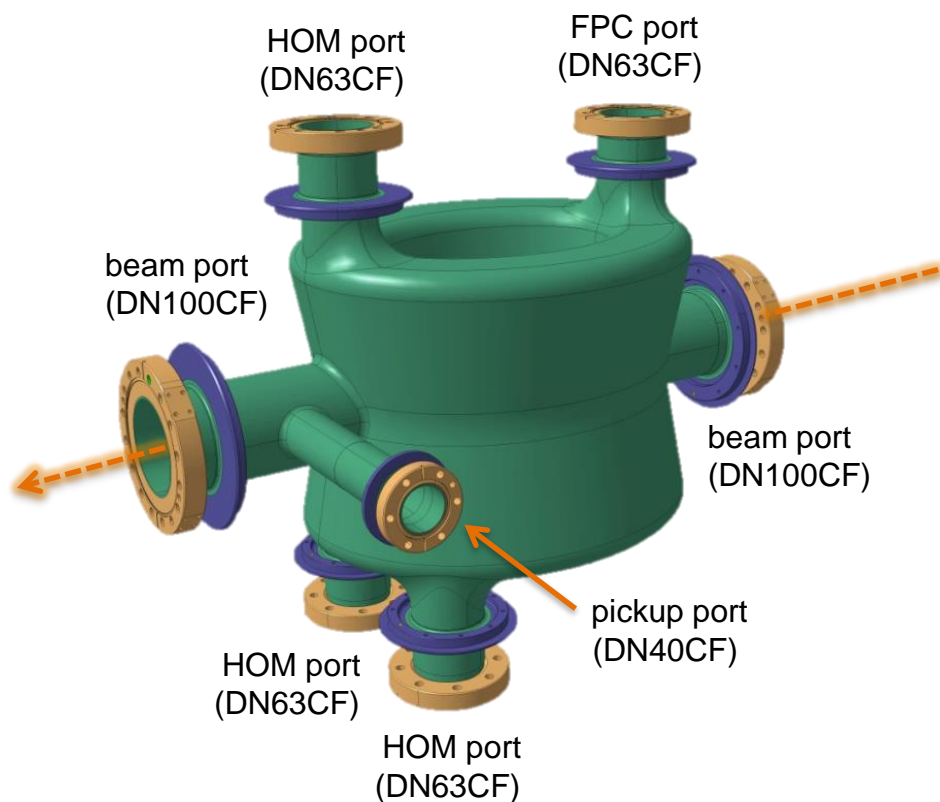

Frequency	400	MHz
First HOM	570	MHz
E_{peak}/V_t	11.1	1/m
B_{peak}/V_t	21.4	mT/MV
V_{acc}/V_t	4.5	kV/MV
U/V_t^2	0.9	J/(MV) ²
R_t/Q	429	Ohm
G	87	Ohm

* maximum B_{peak} between bottom HOM ports

SPS DQW crab cavity: performance

Confirms enhanced nominal deflecting voltage (Feb 2017)

- Fabricated by Niowave Inc. and JLab, surface treatment and RF test at JLab
- Reached $V_t \sim 5.8$ MV before quench (CERN cavity confirmed 5.1 MV few weeks later)

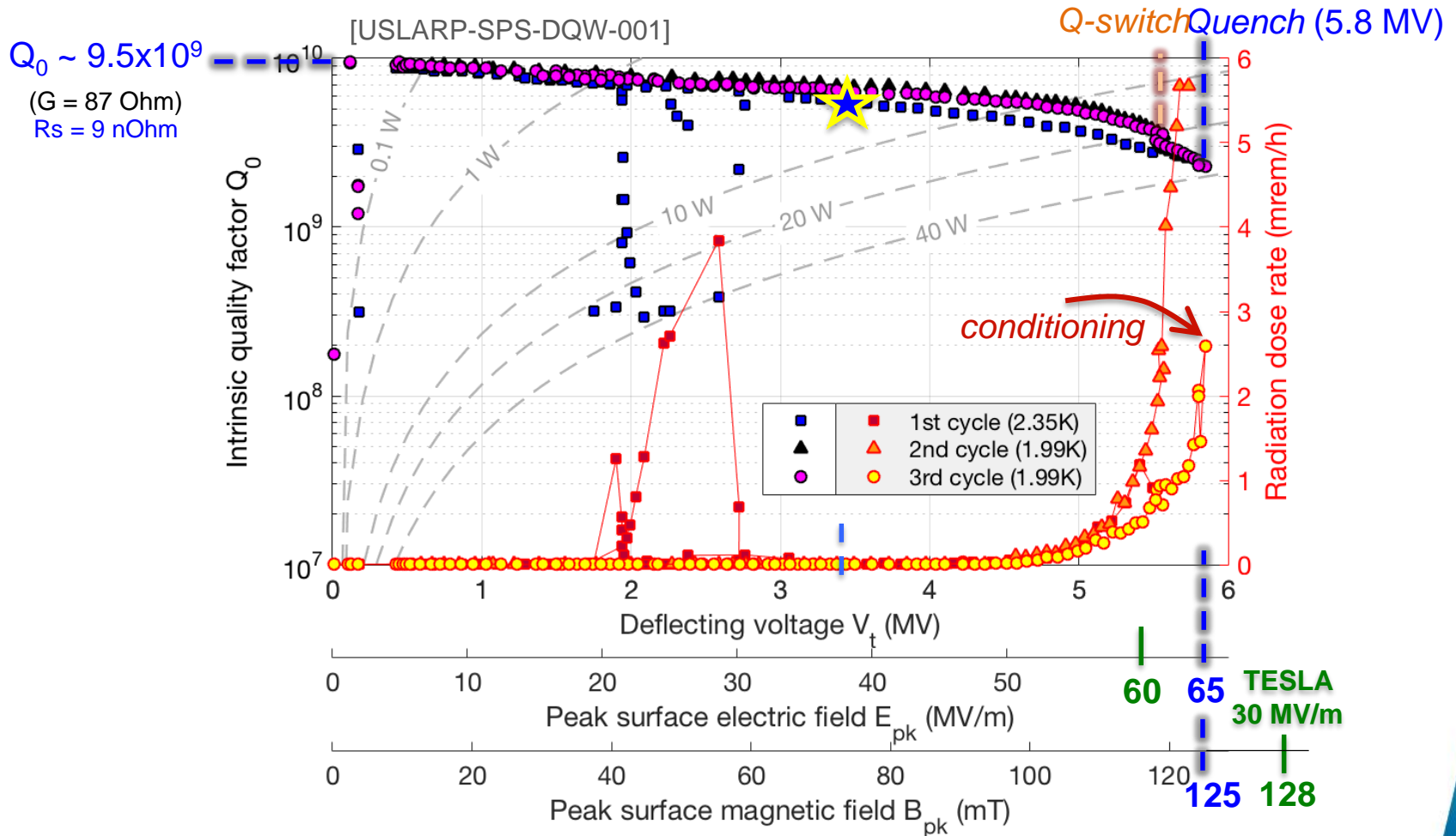

SPS DQW crab cavity: performance (cntd')

Confirms enhanced nominal deflecting voltage (Feb 2017)

- **Multipacting from 1.8-2.8 MV easily processed** within 1st sweep (already shown by PoP); more time and power ($Q_L \sim 5 \times 10^5$) at SPS to fully process multipacting at low field
- **Field Emission (FE) starts beyond nominal V_t** (at $V_t \sim 4.5$ MV when $E_{peak} > 50$ MV/m): good cavity surface treatment, larger ports help to access cavity interior for cleaning

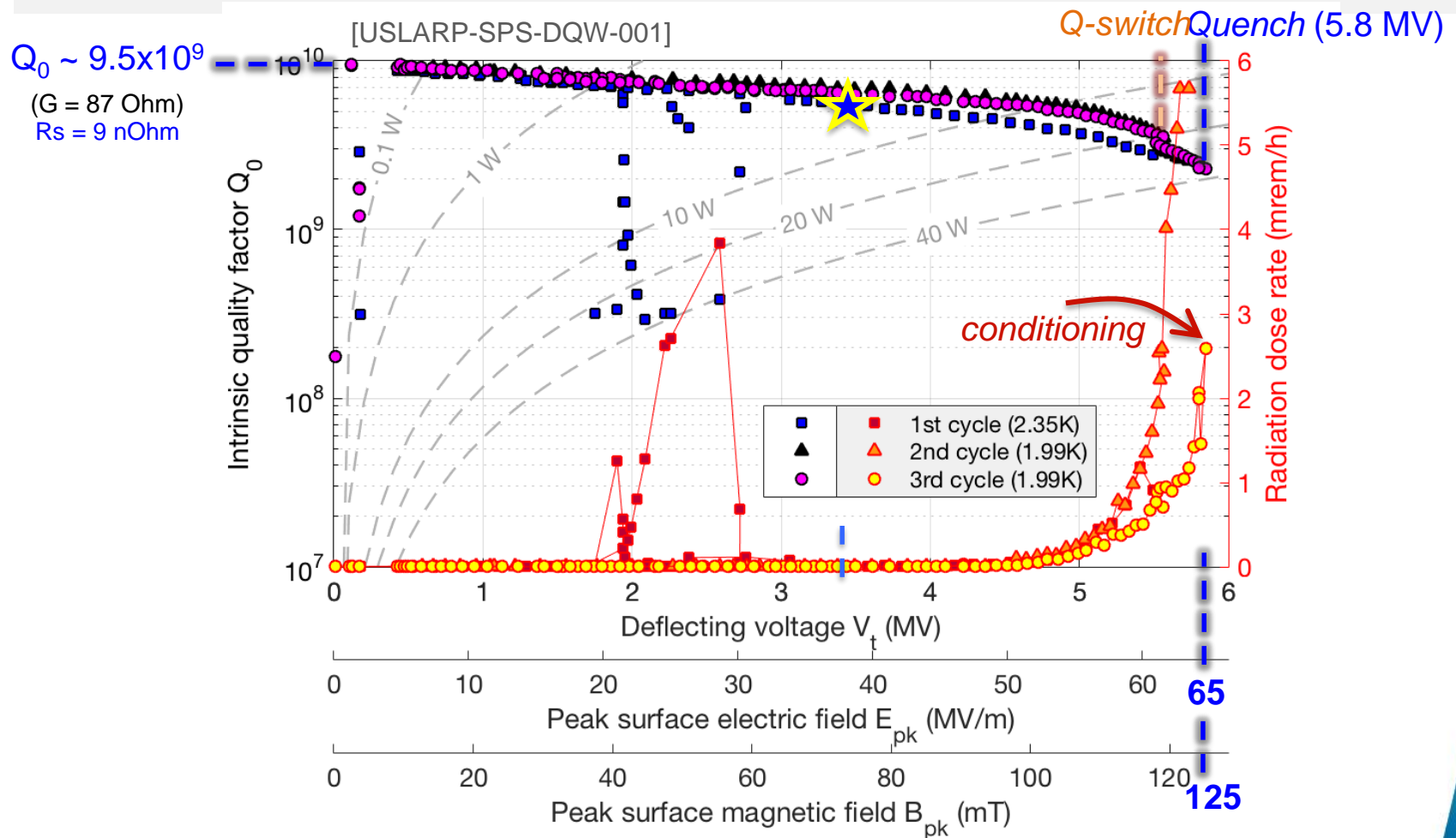

SPS DQW crab cavity: performance (cntd')

- CERNOX #2 is located on FPC port (short port on cavity) blanked with Nb-coated flange during cold tests. Temperature increases abruptly for CX #2 at the same voltage for which Q-switch is observed.
- CERNOX #5 is between bottom HOM ports (highest magnetic field region – 72 mT/3.4 MV). Temperature starts increasing for CX #5 when Bpk ~ 106 mT at the location (deflecting voltage of 5 MV).
- CERNOX #6 and #7 also experience temperature increase. These thermosensors are on the other side of the bottom HOM ports.

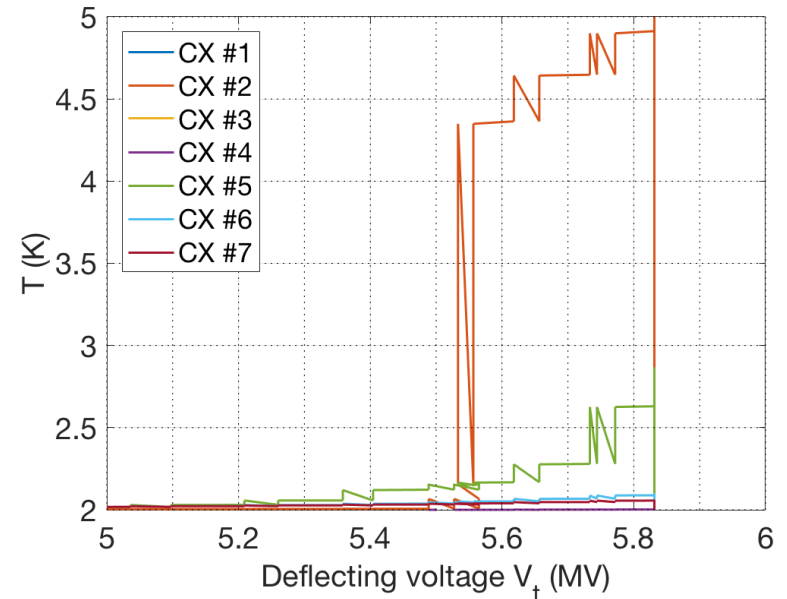
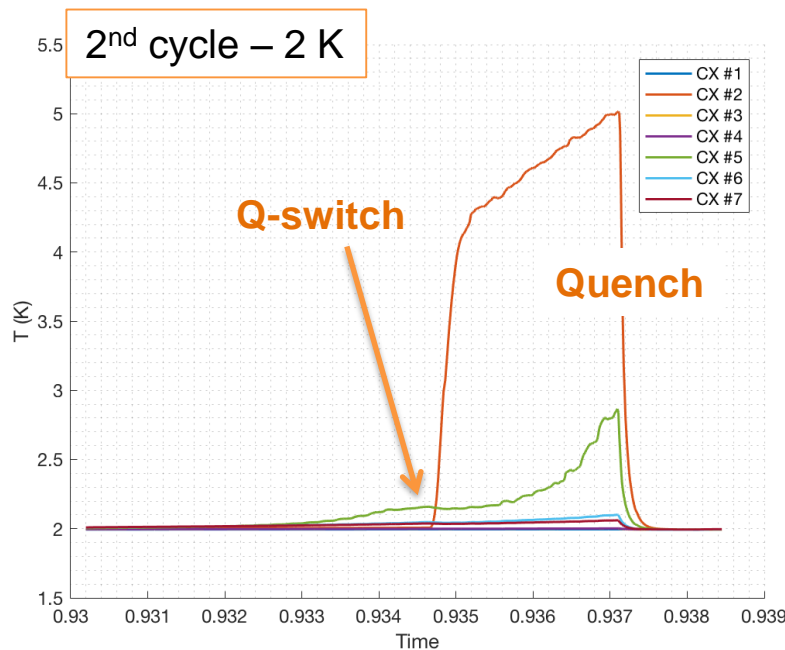

From SPS to LHC-series: improvements

⑦ Explore beyond surface treatment

Better performances are always welcome!

- **EP** may improve surface roughness and further push field-emission onset
- **N-infusion** to reduce high-Q slope, starting at nominal deflecting voltage

SPS DQW crab cavity: HOM dampers design

- Three HOM filters
- Pickup extension for 1.75 GHz mode

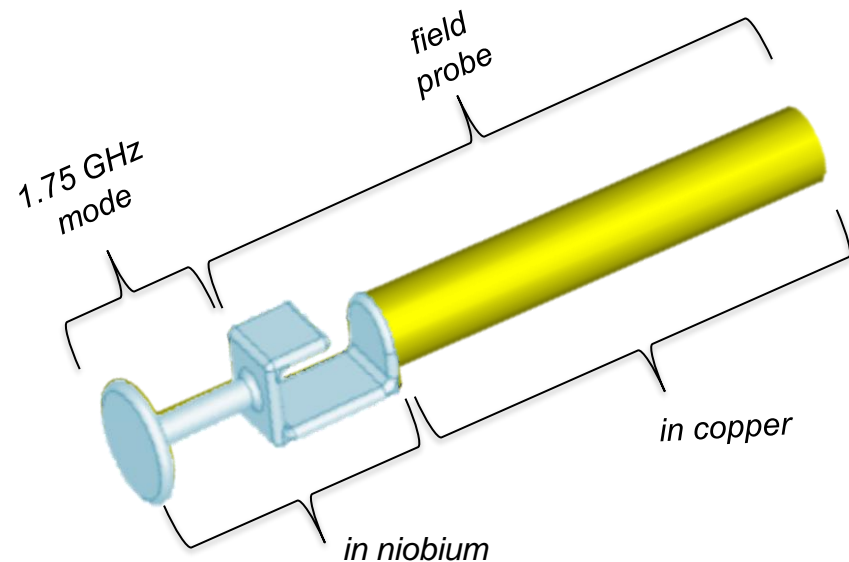
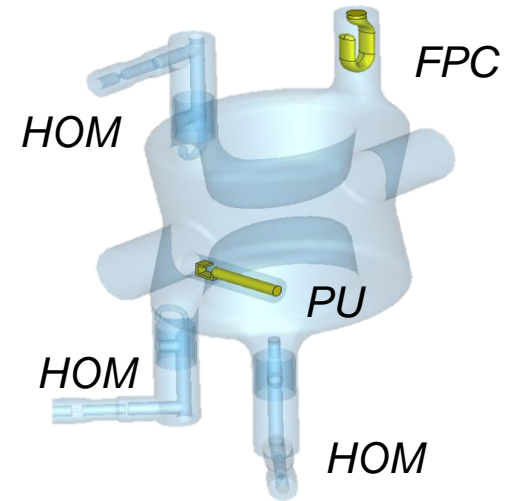
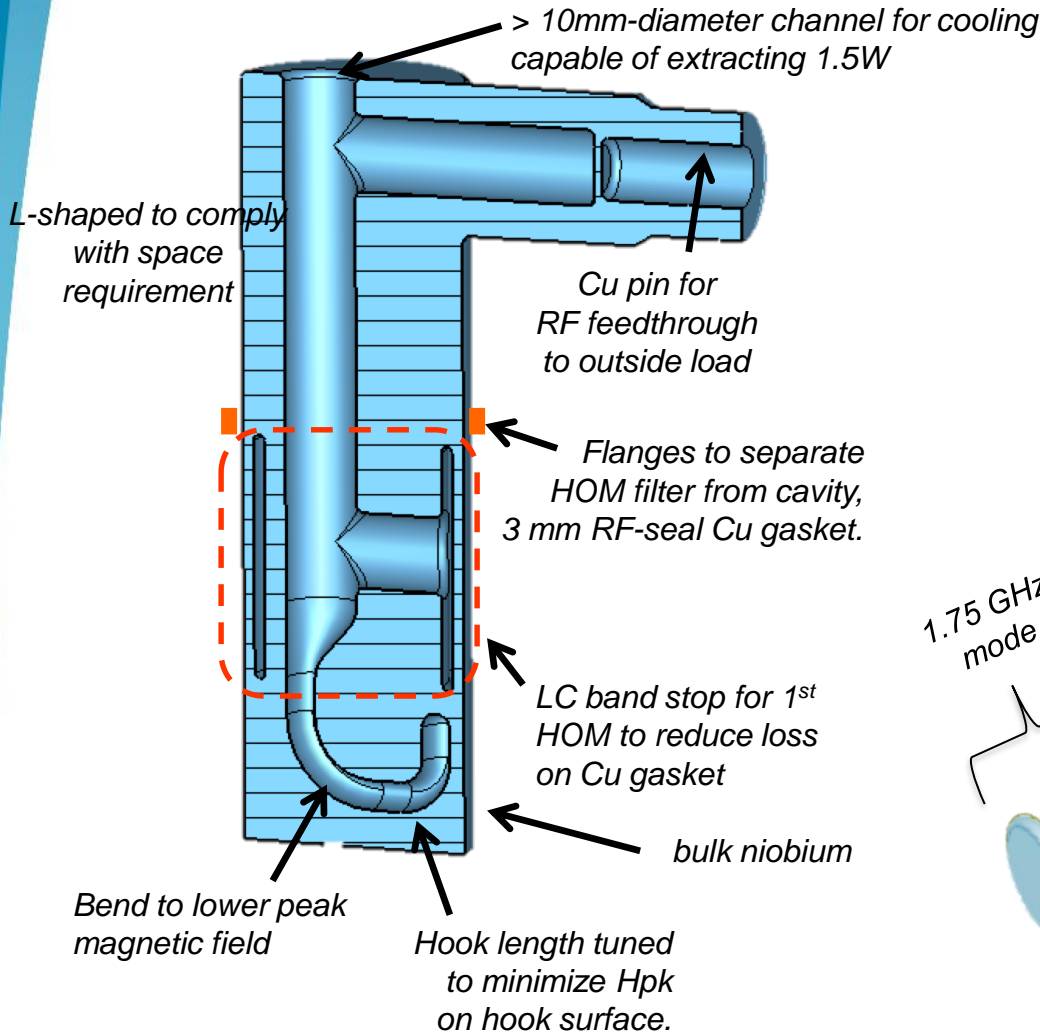

From SPS to LHC-series: improvements

⑧ Impedance reduction for 920 MHz HOM → new HOM filter for LHC

- Length of SPS HOM filter was limited by old cryomodule version
- Proposal: new, longer HOM filter with better performances:
 - Better coupling to 0.6-2.0 GHz modes; lower transmission of 400 MHz mode
 - Lower B_{peak} in hook
 - Both old and new design need pickup to extract 1.75 GHz mode

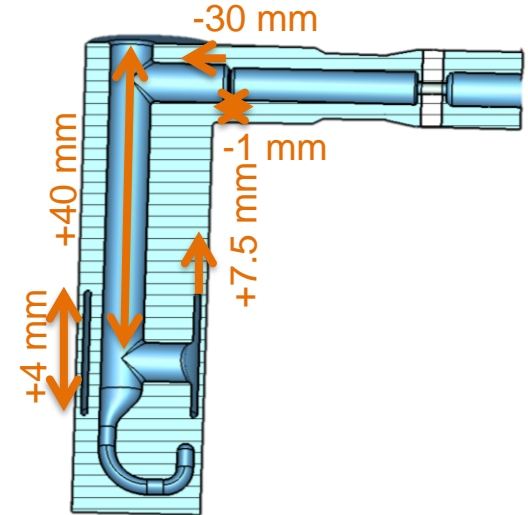

OLD DESIGN (SPS)

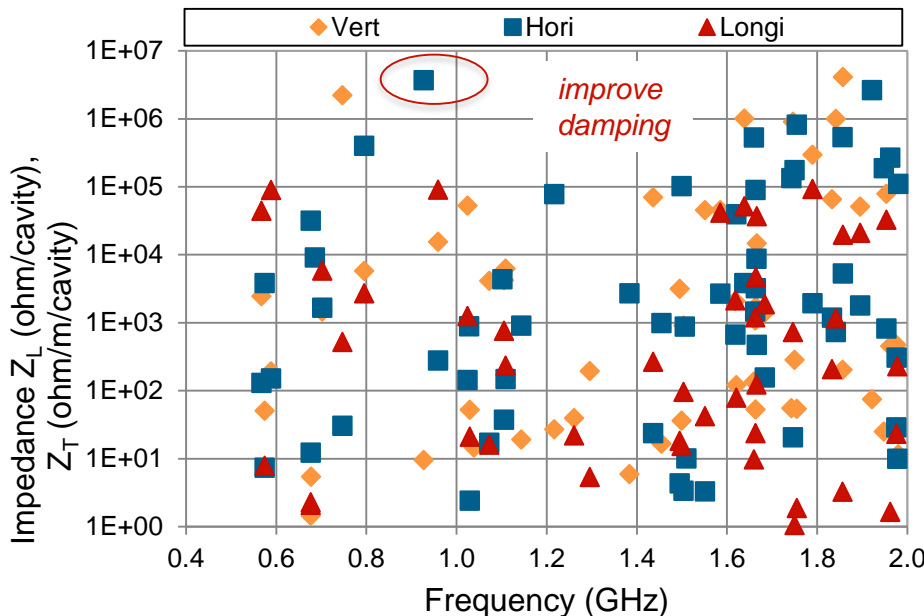

NEW DESIGN (LHC)

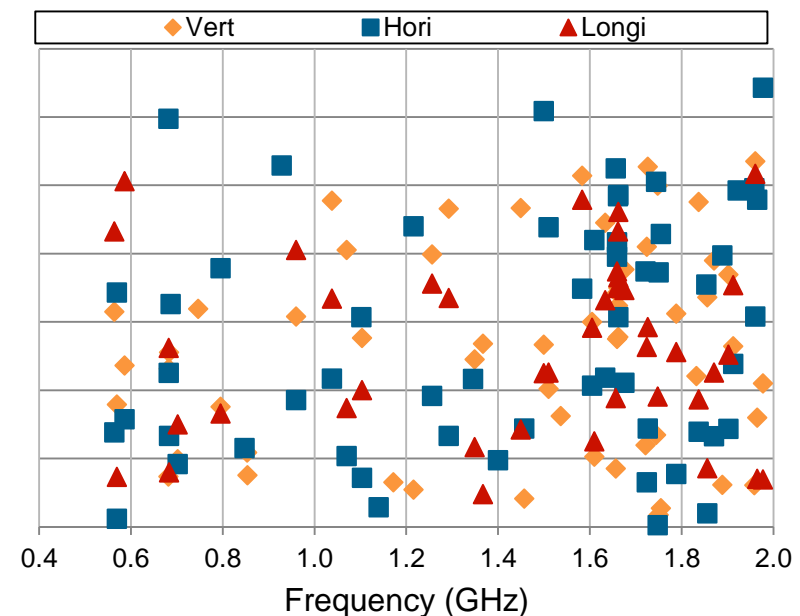

Summary

PoP

- **Validated nominal deflecting voltage:** cavity reached $V_t = 4.7$ MV, $B_{pk} \sim 110$ mT, $2e9$ at high field; $3e9$ at low field limited by quench
- Multipacting easily conditioned



- **Boost performance:** enlarged ports for FPC and HOM power, reduced B_{peak}/V_t
- **Ensured integrability in LHC:** cavity can be used for V and H kick

SPS

- Different fabrication and preparation processes, but still both US and CERN cavities show $V_t > 5$ MV (improved performance w.r.t. PoP cavity) → **robust RF design, validated surface treatment procedures**
- Current **RF cavity design is valid for LHC-series production**
- Cavity **integrated into cryomodule for LHC**
- Tests of cavity with HOM filter and dressed cavity are next



- Explore effects of N-infusion and electro-polishing on performance
- More space for longer HOM filter; lower losses, better rejection fundamental mode, better coupling 0.6-2.0 GHz modes.

HL-LHC

Conclusions

- Gained **experience** from PoP and SPS-series cavities, with **successful** bare cavity cold tests: these cavities work **well beyond the necessary field!**
- **Developed and demonstrated** the **processes** needed to provide a DQW cavity with 1) **good surface quality** and 2) **at target frequency**.
- Identified **possible improvements** currently under study and some already implemented.
- Last but not least, **remember the lessons learned!** Extensive **documentation** prepared to track cavity evolution and changes.

From SPS to LHC-series: improvements

- ⑧ Impedance reduction for 920 MHz HOM → new HOM filter for LHC

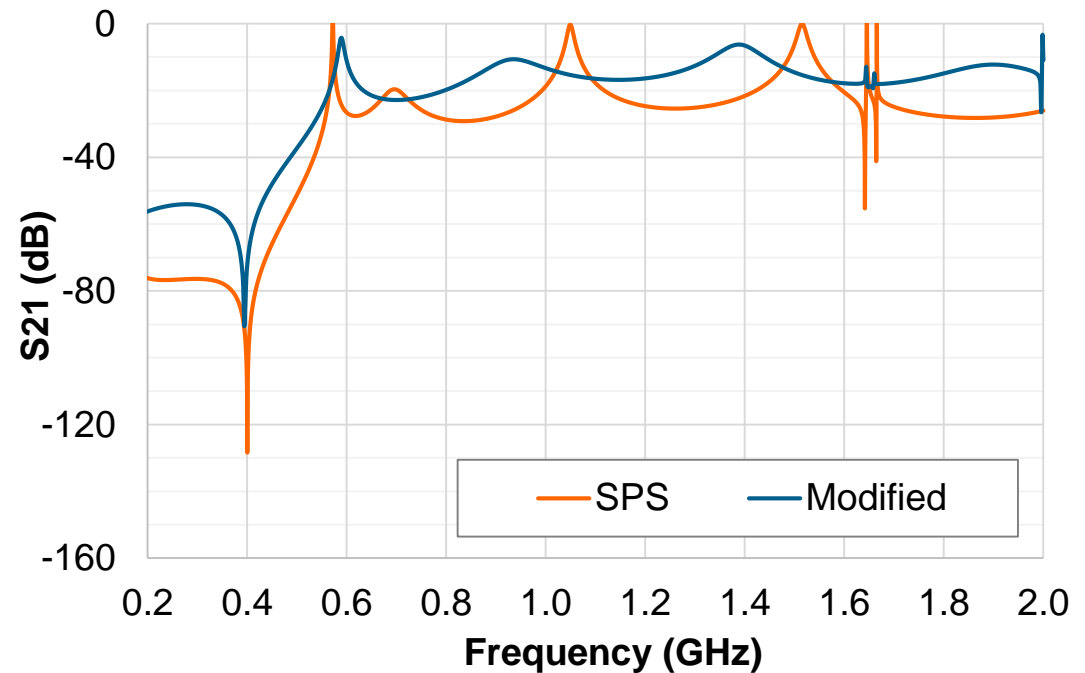
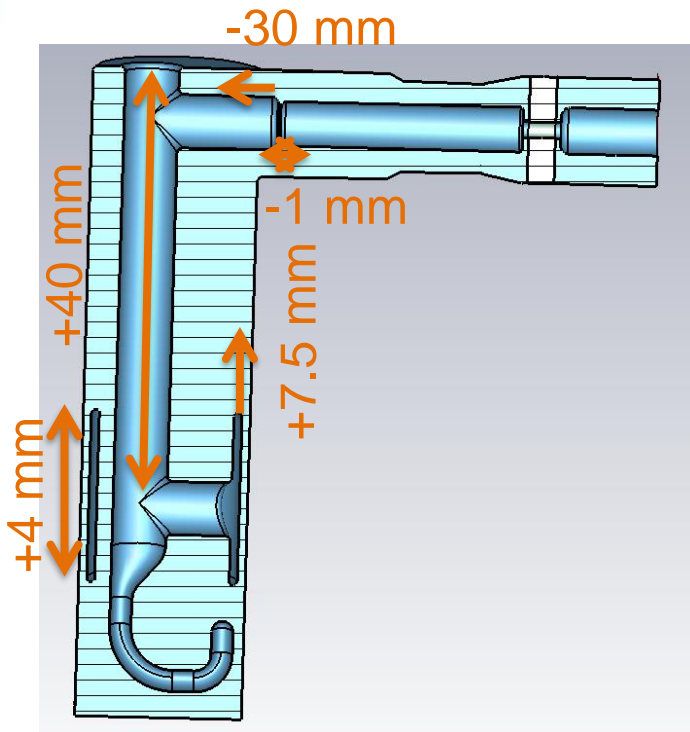

SPS DQW crab cavity: pickup design

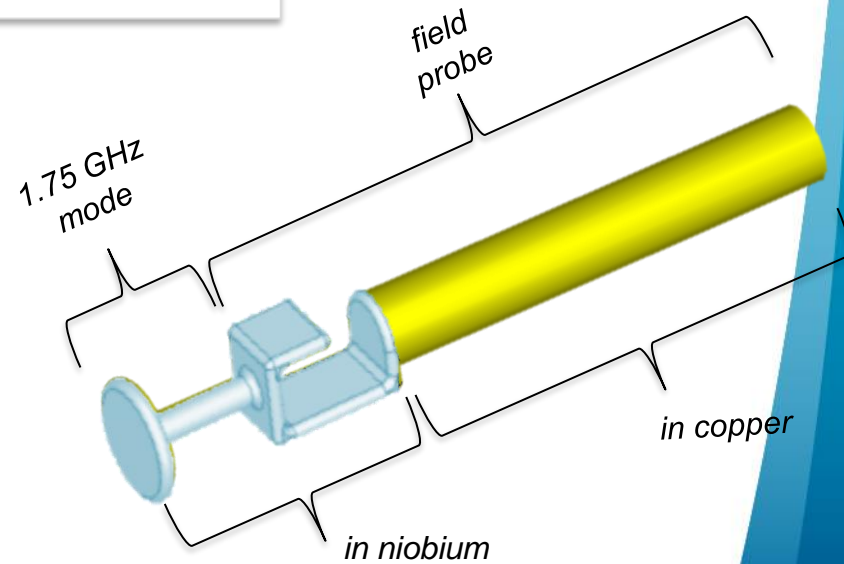
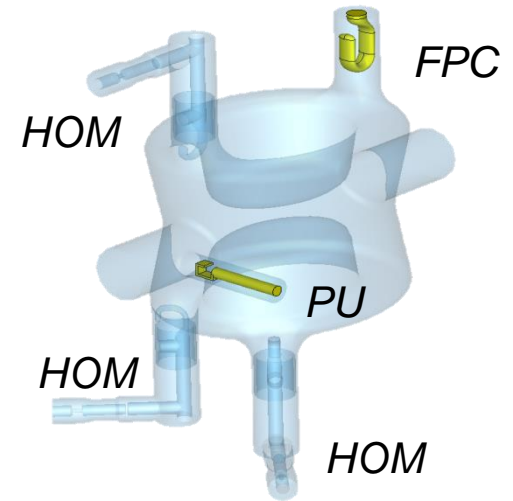
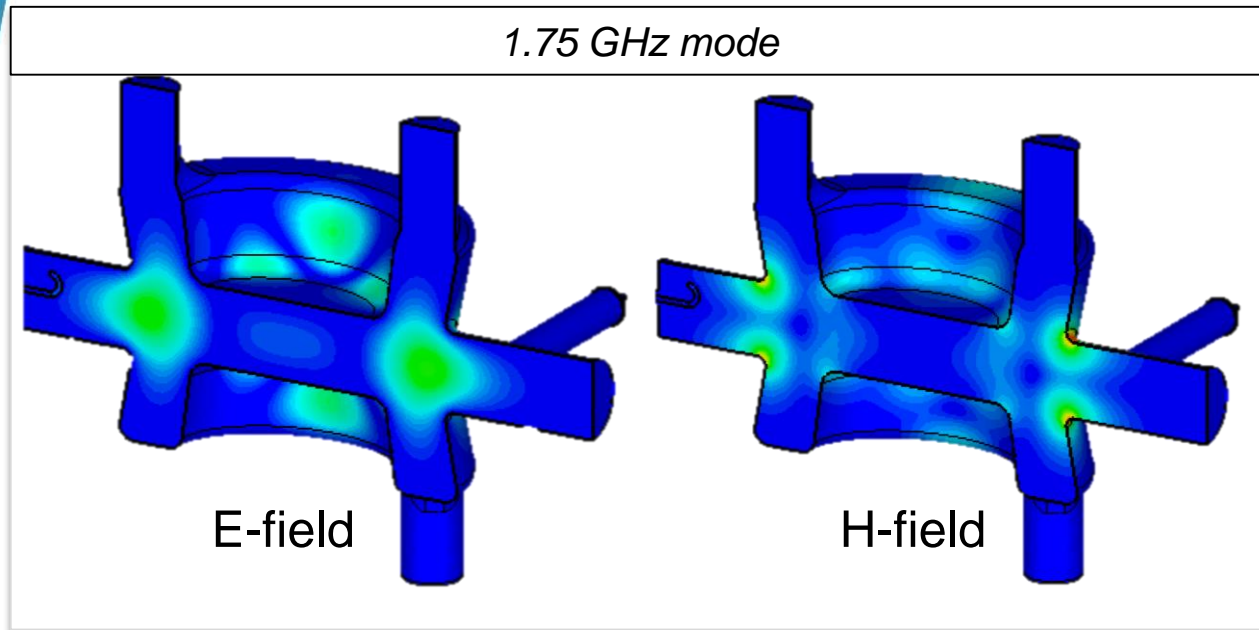

CERN-DQW-001: *model vs fabricated*

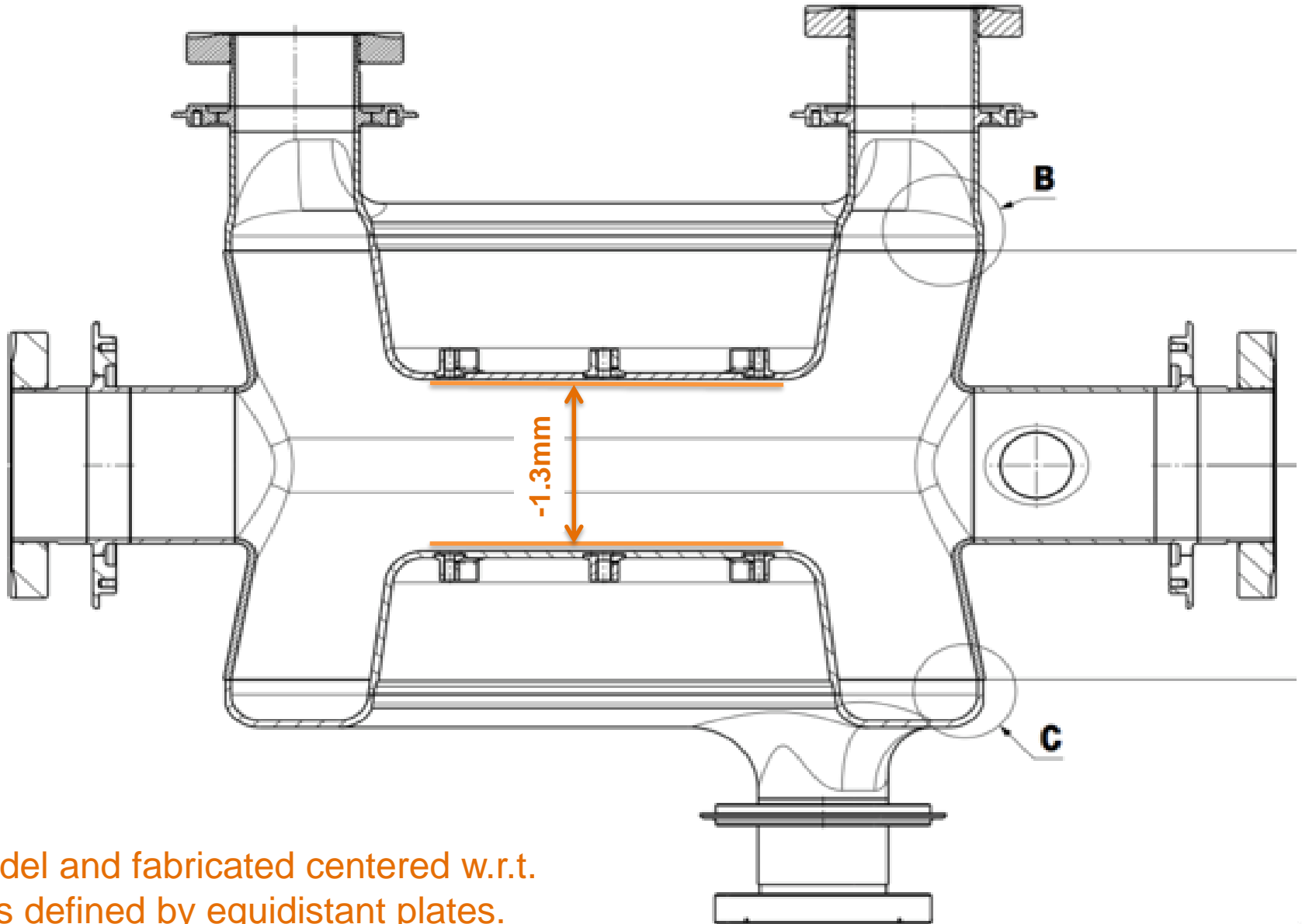

Model and fabricated centered w.r.t.
axis defined by equidistant plates.