

# Vertical EP successfully applied to the LHC Crab cavity

## VEP conditions

Average current: 120 A

Average current density: 17.6 mA/cm<sup>2</sup>

Applied voltage: 16~17 V

Electrolyte flow rate: 15L/min

Electrolyte temperature: 28 degC

Cavity cell temperatures < 40 degC

Total integrated current: 293 Ah

## VEP results

Average removal thickness: 35  $\mu\text{m}$

1. Top plate: 44  $\mu\text{m}$
2. Bottom plate: 22  $\mu\text{m}$
3. Upper wall: 30  $\mu\text{m}$
4. Lower wall: 80  $\mu\text{m}$

Large removal. Need to improve. Turnover during polishing is an option.

**Sufficient surface removal obtained**

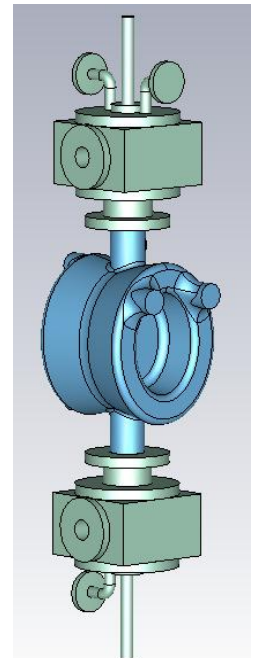
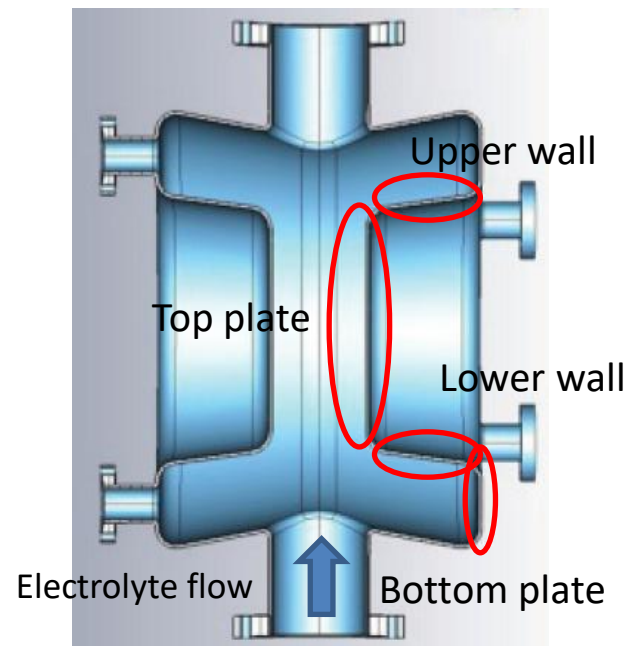
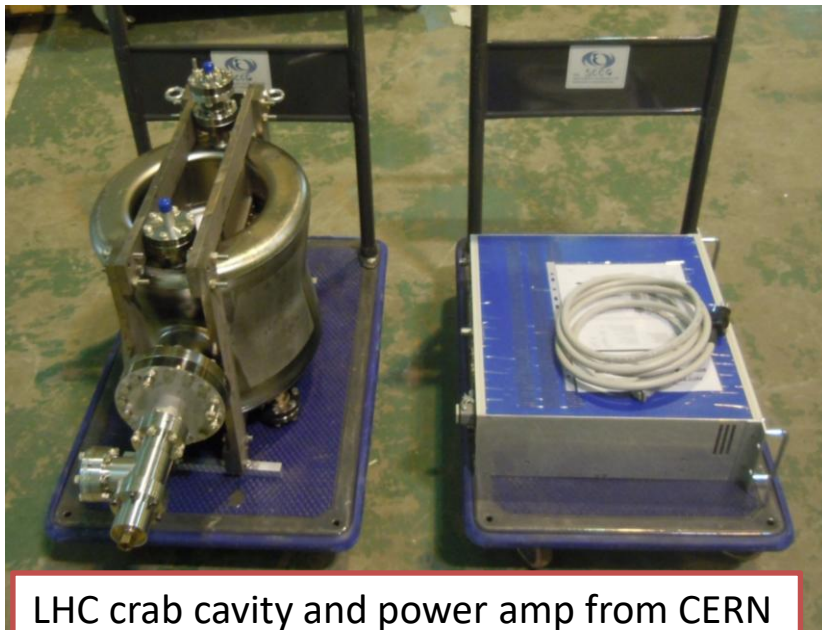

# Applied voltage and current

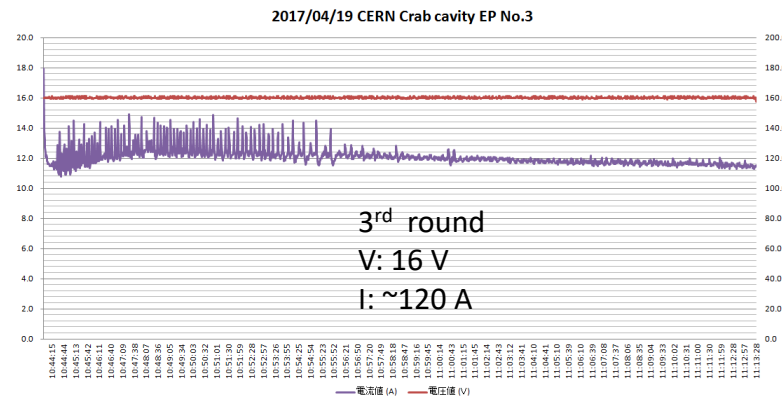
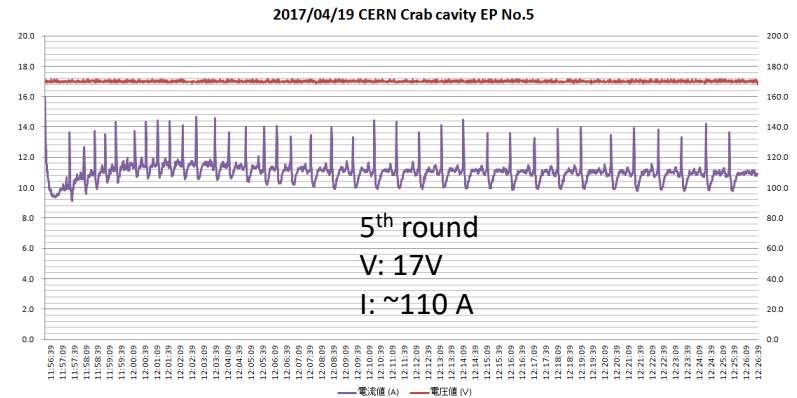
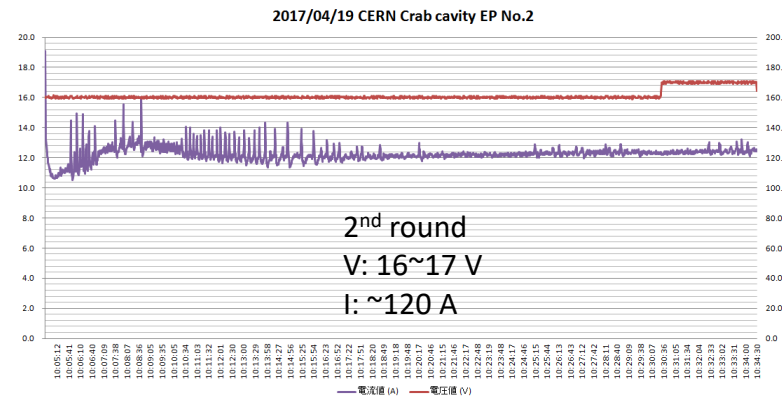
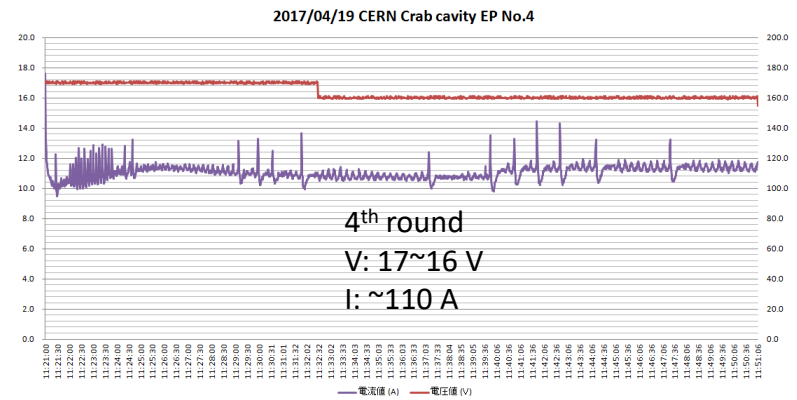
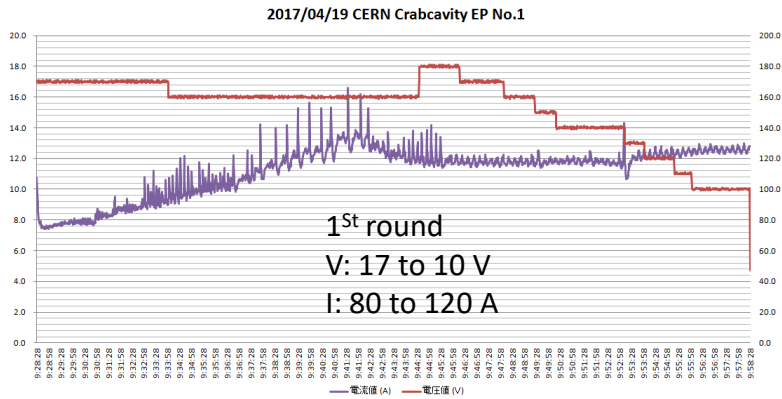

We stopped VEP every 30 minutes to check the surface removal measured with an ultrasonic thicknessmeter

Average voltage: 17 V  
Average current: 120A  
Average current density: 18 mA/cm<sup>2</sup>

# Temperatures during VEP

2017/04/19 CERN Crab cavity surface temperature at EP (°C)

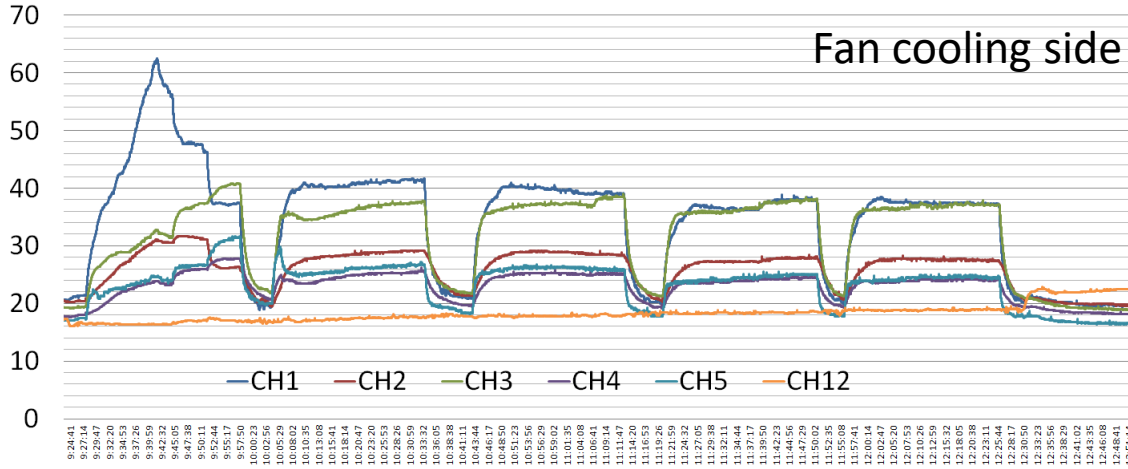

CH12: VEP room temperature

2017/04/19 CERN Crab cavity surface temperature at EP (°C)

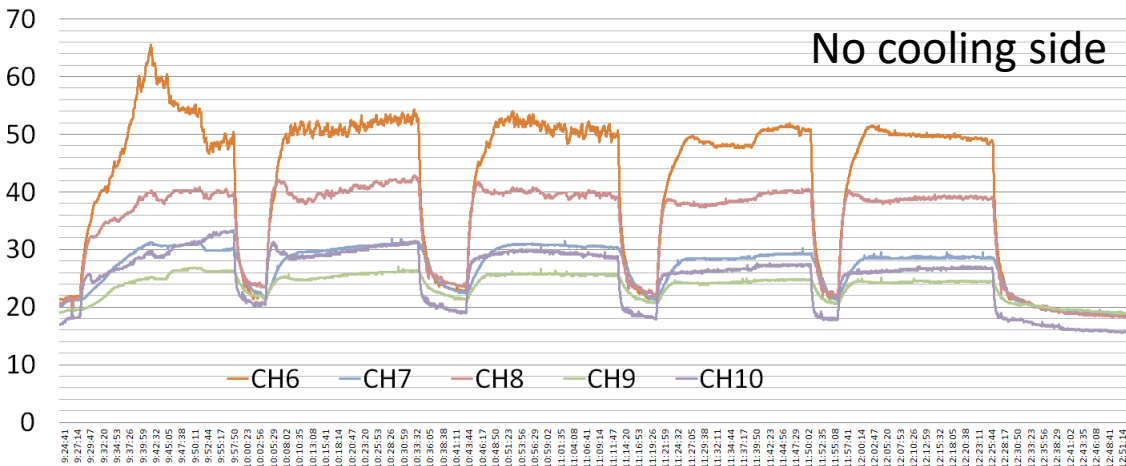

Temperatures at the upper beam pipe were higher than others. Temperatures at the top plate of the inner conductor were around 40 deg. Other temperatures were below 30 deg. We plan to apply more cooling fans to cool down the upper beam pipe.

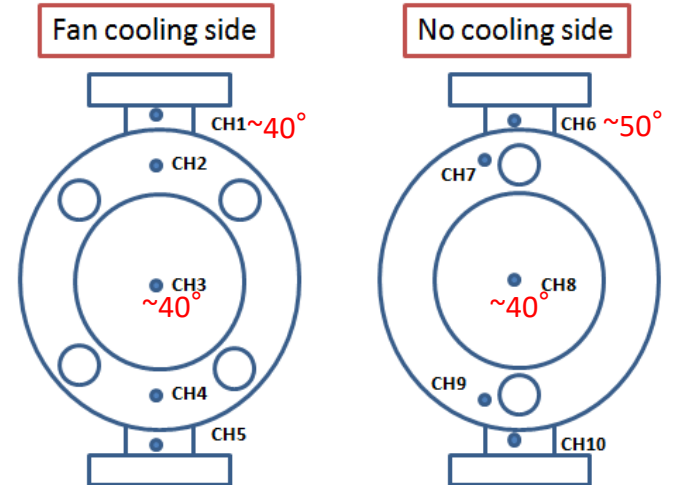
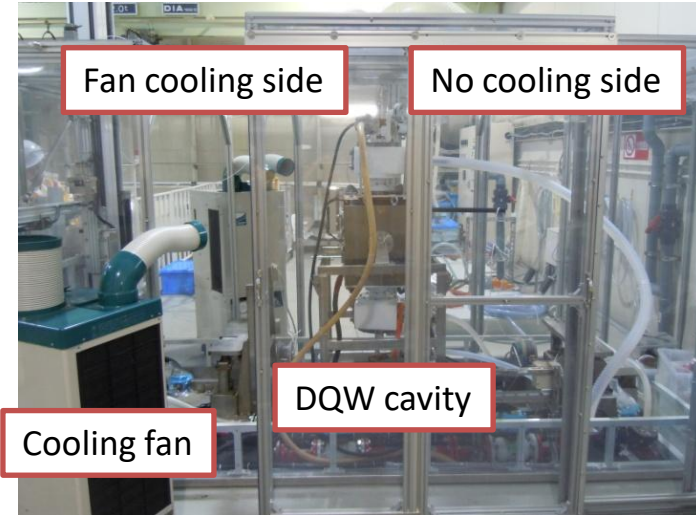

# Setting up EP apparatus



# Vertical EP at KEK



Tilt the cavity to remove air

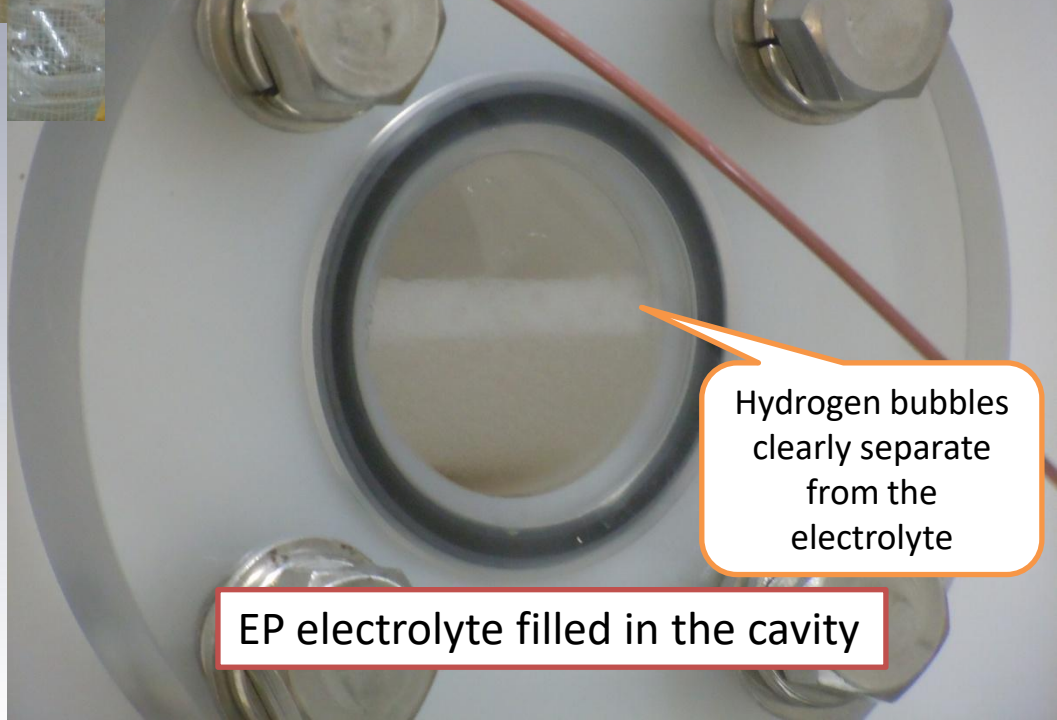
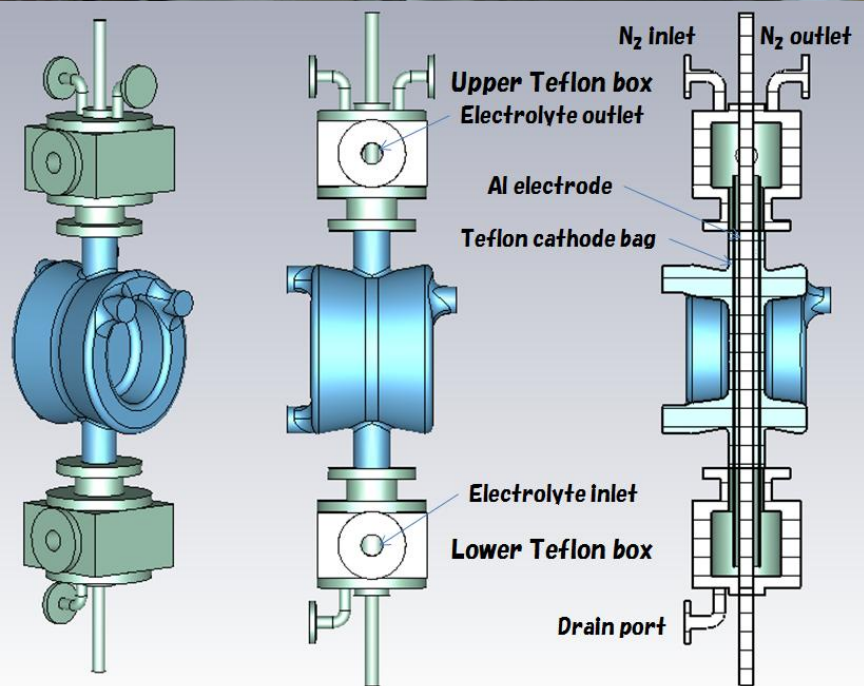

Hydrogen bubbles clearly separate from the electrolyte

EP electrolyte filled in the cavity

# After VEP



Taking off the central electrode



Taking off Teflon boxes

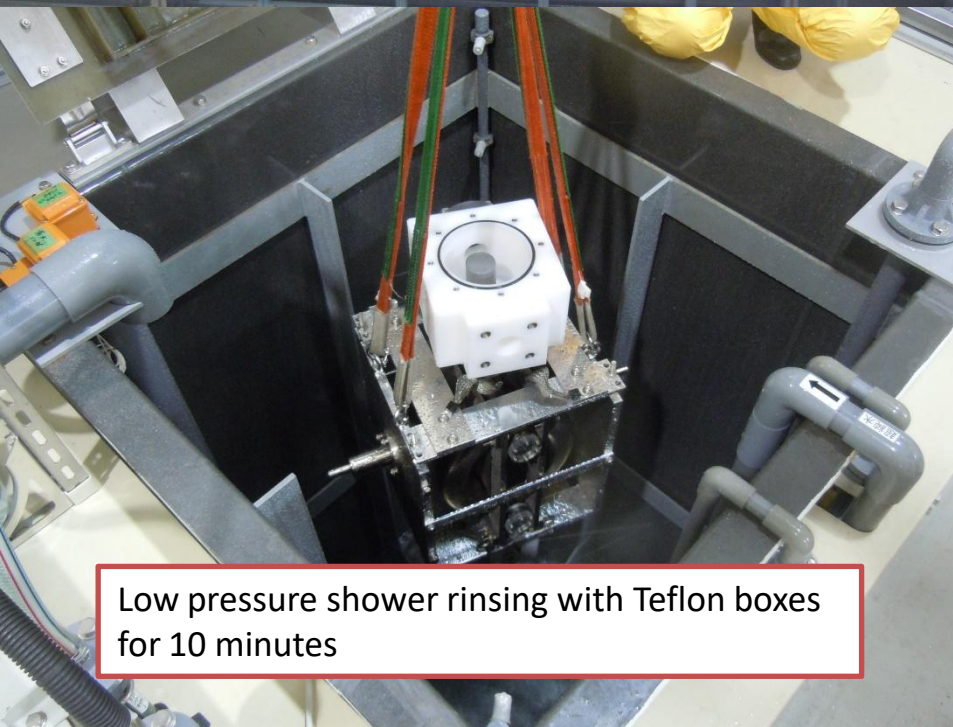

Low pressure shower rinsing with Teflon boxes for 10 minutes



Inspection of the inner surface

## Rinsing procedure



Ozonized water rinsing for 10 minutes with overflowing ozonized water

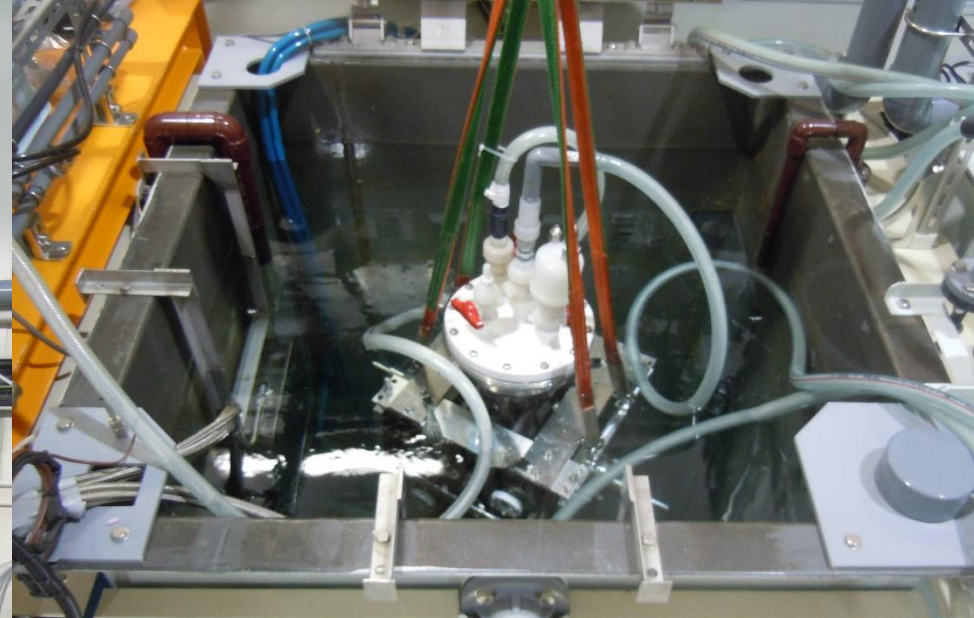

Ultra sonic rinsing for an hour in a 50 C hot water bath



Cavity in our clean room

# Assembly in our clean room

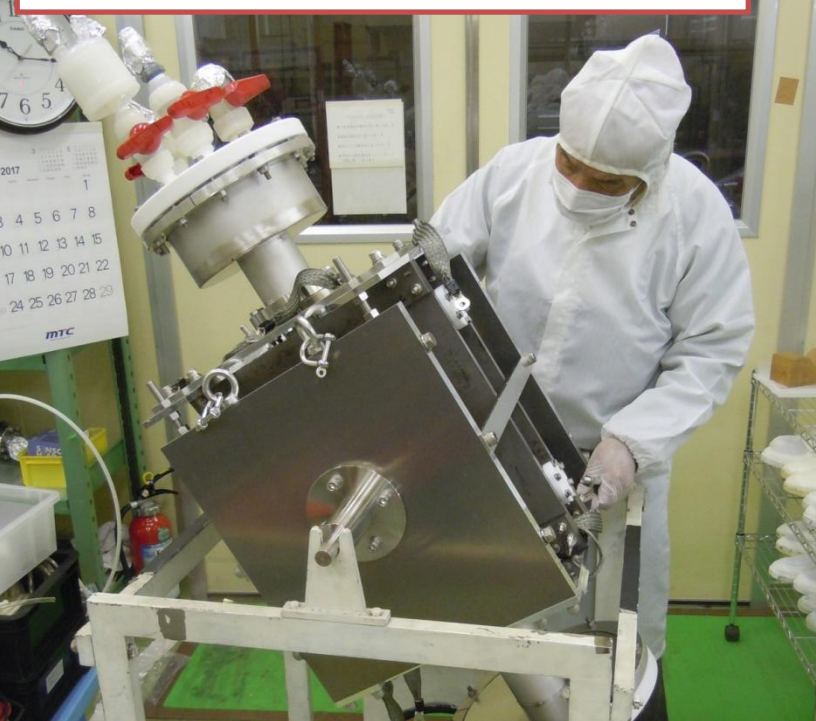

Almost all port flanges leaked several times before we used annealed gaskets from CERN. Micro-particles may contaminate the cavity during the gasket exchange.

# Cold test of the LHC crab cavity at KEK

Our cold test stand modified from the KEKB system successfully cooled the cavity to 2K. Newly developed 400 MHz RF measurement system worked well to measure the cavity performance before and after the VEP.

Results of cold tests

1. Q factors are almost the same at low fields. Significant improvement was not observed for this cavity.
2. Heating at beam pipe flanges limited its fields.
3. Field emission was observed at relatively low fields (2.6MV), suggesting particle contamination during leakage repairing.

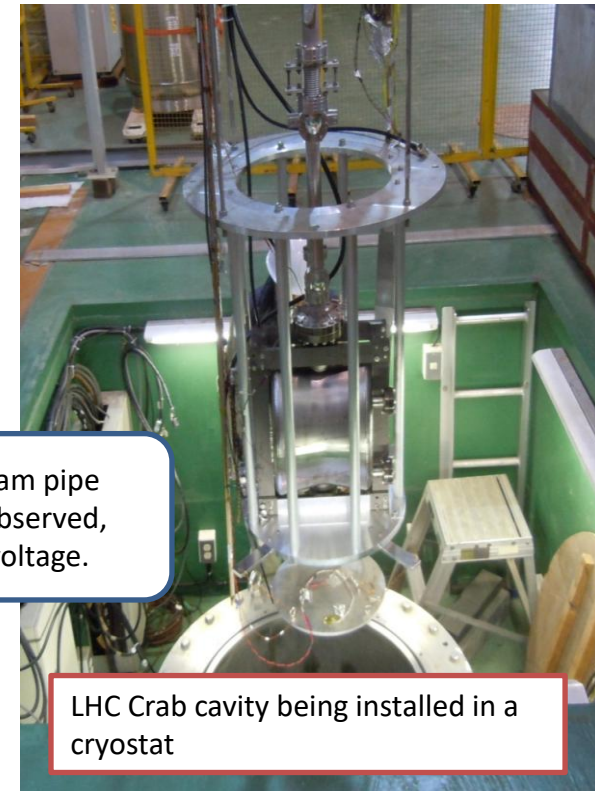
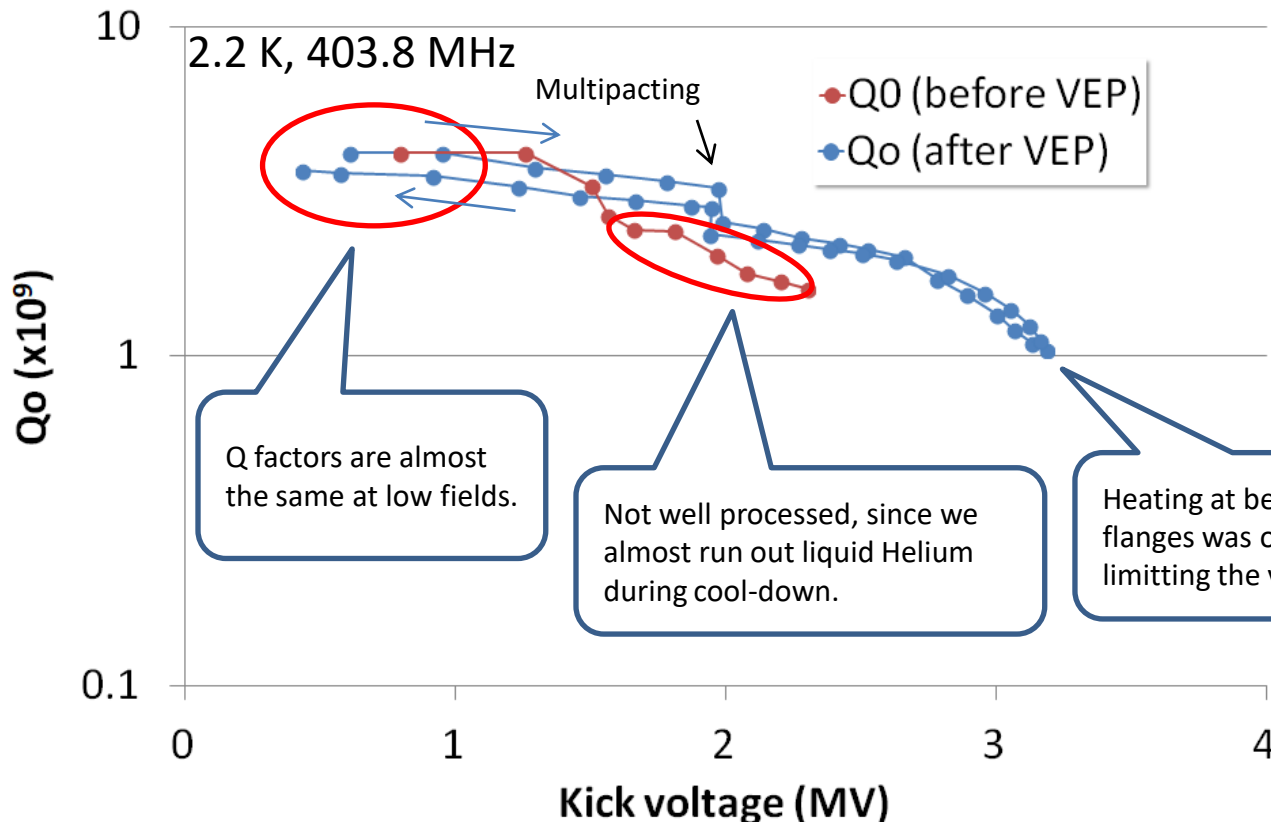

# Future plans

- VEP application to another cavity
  - BNL-type double quarter wave cavities for the SPS beam test.
  - Examine the possibility to improve the field emission at high fields by VEP.
  - Fabrication of a new cavity holder and a flange for rinsing after VEP designed for the SPS cavity was completed.
- Development of high pressure rinsing system at KEK
  - Dedicated system for LHC-crab cavities needed after VEP.

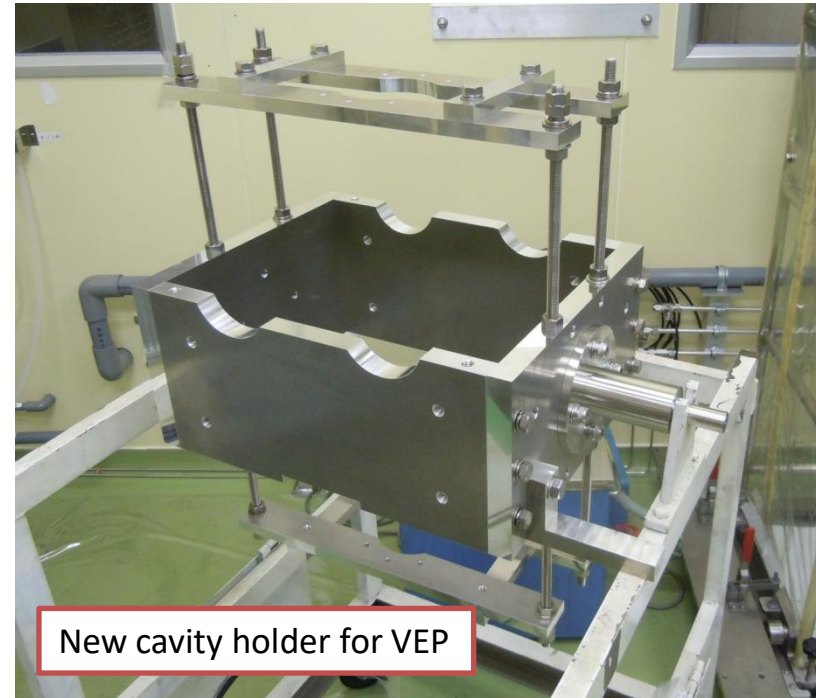

New cavity holder for VEP

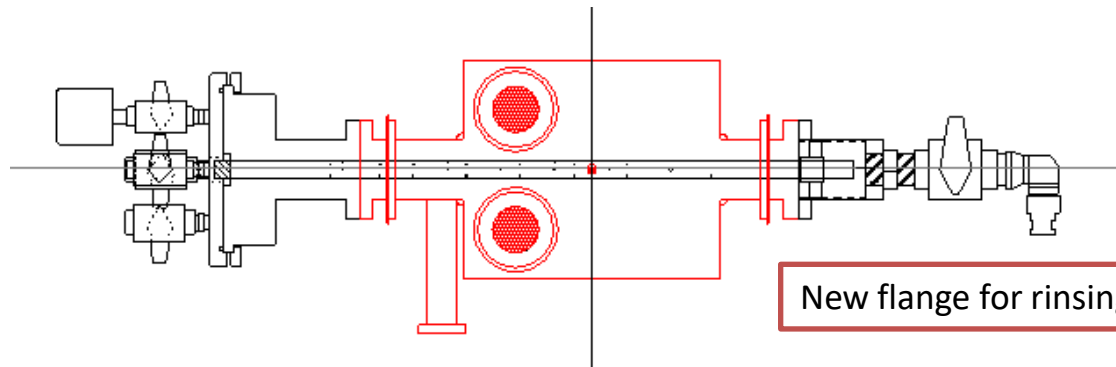

New flange for rinsing