



MQXF Status and Plans

Paolo Ferracin and Giorgio Ambrosio
on behalf of the MQXF collaboration

7th HL-LHC Collaboration Meeting
13-16 November 2017
CIEMAT, Madrid, Spain

Acknowledgments

- **CERN**

A. Ballarino, H. Bajas, M. Bajko, B. Bordini, S. Izquierdo Bermudez, A. Chiuchiolo, J. Ferradas Troitino, C. Fichera, L. Fiscarelli, L. Fleiter, A. Foussat, P. Grosclaude, M. Guinchard, P. Hagen, O. Housiaux, F. Lackner, P. Moyret, J.C. Perez, H. Prin, R. Principe, E. Rochepault, T. Sahner, S. Sequeira Tavares, E. Todesco, G. Vallone

- **BNL**

M. Anerella, A. Ghosh, P. Joshi, P. Kovach, A. Marone, J. Muratore, J. Schmalzle, P. Wanderer

- **FNAL**

G. Ambrosio, G. Apollinari, J. Blowers, R. Bossert, R. Carcagno, G. Chlachidze, L. Cooley, E. Holik, S. Krave, V. Lombardo, F. Nobrega, I. Novitsky, C. Santini, C. Sylvester, S. Stoynev, T. Strauss, M. Tartaglia, D. Turrioni, M. Yu

- **LBNL**

E. Anderssen, D. Cheng, D.R. Dietderich, R. Hafalia, M. Marchevsky, H. Pan, I. Pong, S. Prestemon, E. Ravaioli, G. Sabbi, X. Wang

- **SLAC**

Y. Nosochkov

- **CEA Saclay**

H. Felice

- **LASA**

V. Marinozzi, M. Sorbi

- **Tampere University of Technology**

T. Salmi



Outline

- Short models
- Prototypes
- Overview of series production

Short model program

Coil fabrication

- 1st generation coils: **13**
 - CERN: **7**
 - 1 Cu and 1 low-grade
 - 3 RRP 132/169 and 2 PIT
 - LARP: **6**
 - All RRP 108/127
- Available for test: **8**
- **1** tested in MQXFSM1
 - Coil 2
- **4** tested in MQXFS1
 - 103,104,3,5
- **4** not tested (MQXFS2)
 - 102 (splice issue)
 - 201- 202 (low J_c and RRR)
 - Coil 6

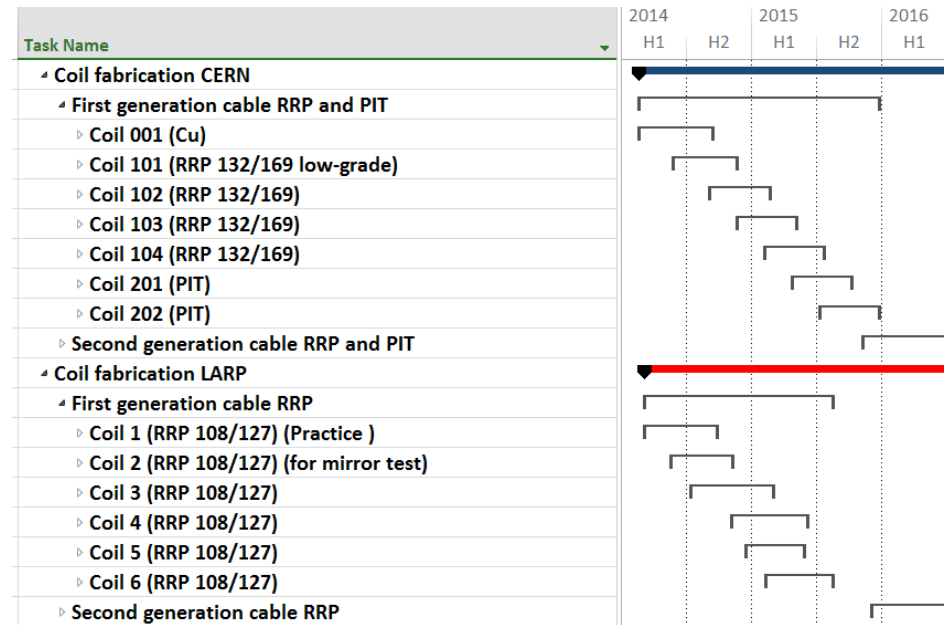

Short model program

Coil fabrication

- 2st generation coils: **21** planned
 - CERN: **18**
 - RRP: 3 (132/169) and 5 (108/127)
 - PIT: 5 (no barrier) and 5 (barrier)
 - LARP: **3**
 - RRP 1 (144/169) and 2 (108/127)
- **5** to be tested in MQXFS3
 - 105,106,107,7 (8)
- **5** to be tested in MQXFS5
 - 203,204,205,206 (207)
- **5** to be tested in MQXFS4
 - 108,109,110,111 (112)
- **5** to be tested in MQXFS6
 - 208,209,210,211 (212)
- **1** to be tested in MQXFS1e
 - 9

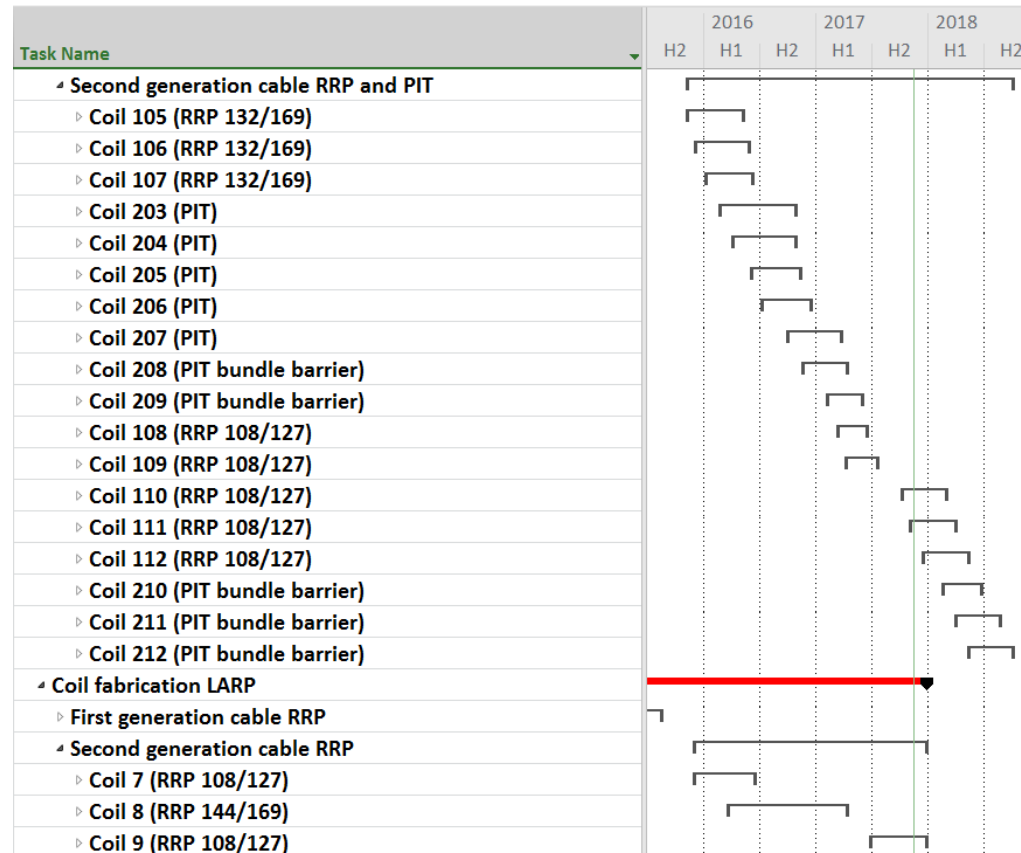

Short model program

Coil fabrication

- Summary
 - **27** coils fabricated from early 2014
 - **19** by CERN
 - **8** by LARP
 - **7** coils to be fabricated by mid 2018
 - **6** by CERN
 - **1** by LARP
 - Total: **34** coils
- Spare or not tested (without major NC)
 - 2nd generation: 207, 107, 212
 - 1st generation: 6

Short model program Magnets

- MQXFS mirror
- MQXFS1
 - RRP coils, first generation cable (a)
 - azimuthal and axial increase (b and c)
 - Stainless steel shell and coil with smaller wedge gap (d and e)

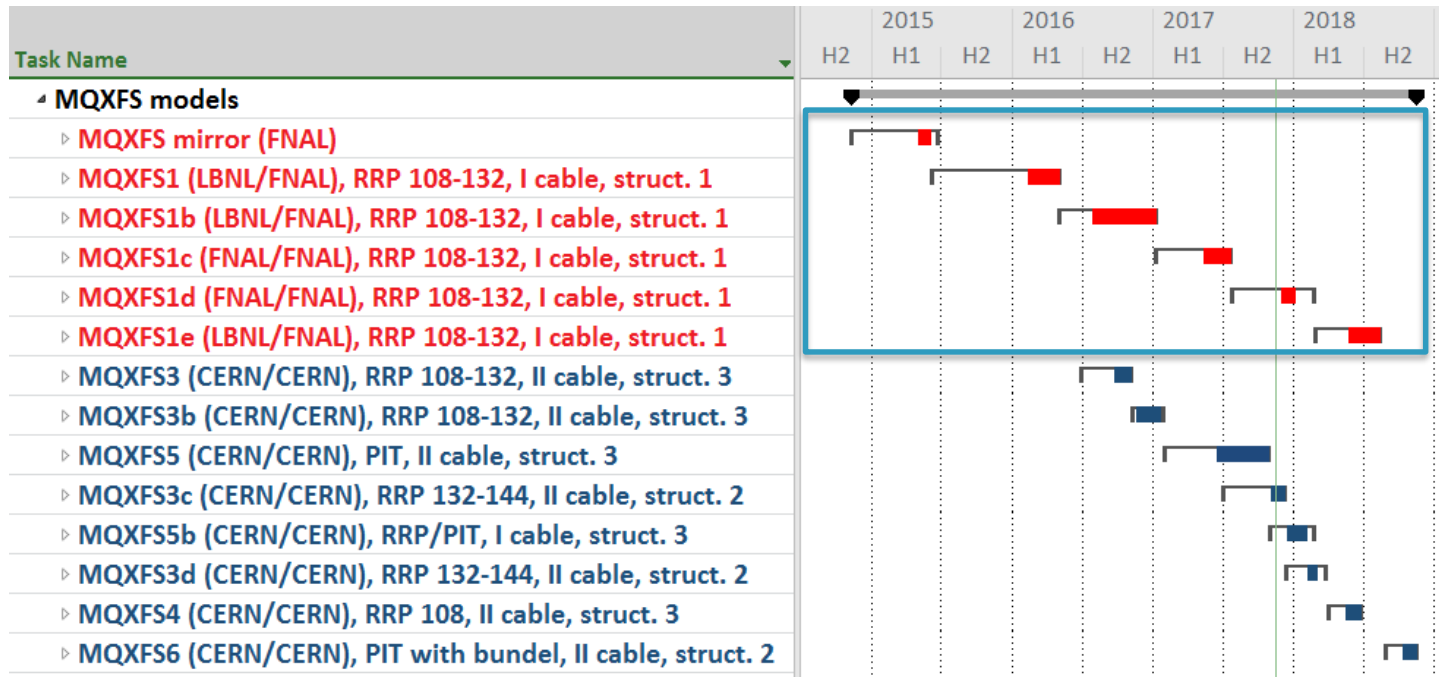

- Test FNAL
- Test CERN
- Test BNL
- Shipment

Short model program Magnets

• MQXFS3

- RRP coils, second generation cable (a)
 - Axial increase (b), change of coil with azimuthal increase (c), stainless steel shell + beam screen (d)

• MQXFS5 (PIT)

- RRP coils, second generation cable (a)
 - Beam screen (d)

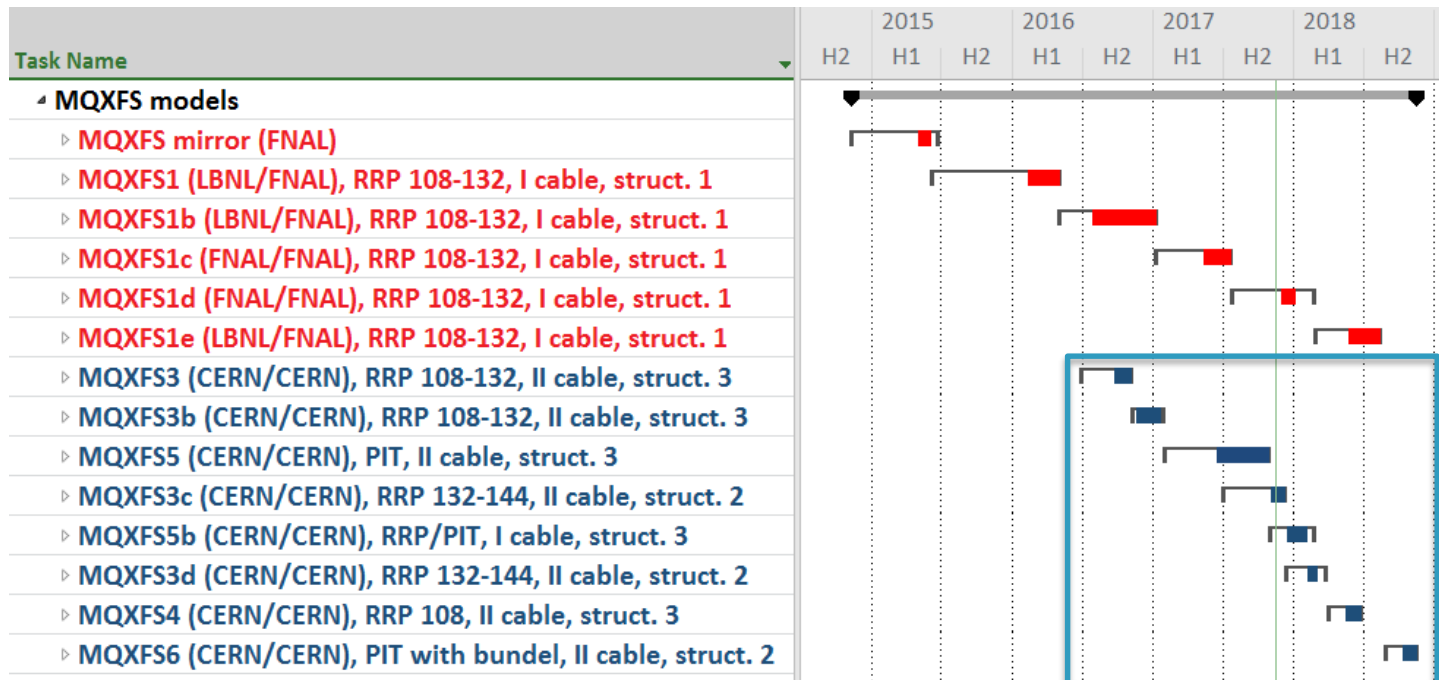

Short model program Magnets

- **MQXFS4**
 - RRP (final) coils, second generation cable (a)
- **MQXFS6** (PIT)
 - PIT (with bundle) coils, second generation cable (a)
- Test to be added: 2000 powering cycles

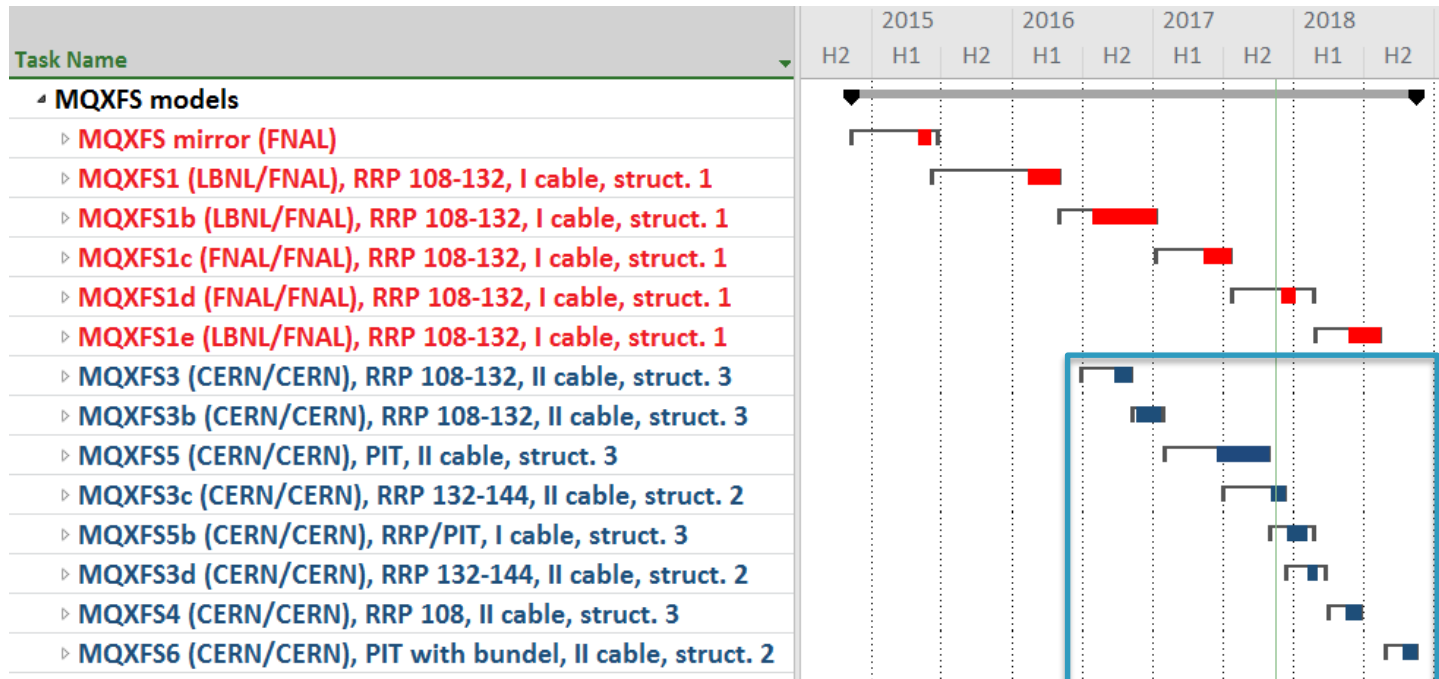

- Test FNAL
- Test CERN
- Test BNL
- Shipment

Test of cold bore tube and beam screen

- After test of MQXFS5
 - Insertion of cold bore and beam screen 1 in vertical position (no bumpers) → [MQXFS5b](#) in Jan-Feb/2018
- After test of MQXFS3c
 - Insertion of cold bore and beam screen 2 in horiz. position (bumpers) → [MQXFS3d](#) in Mar-Apr/2018

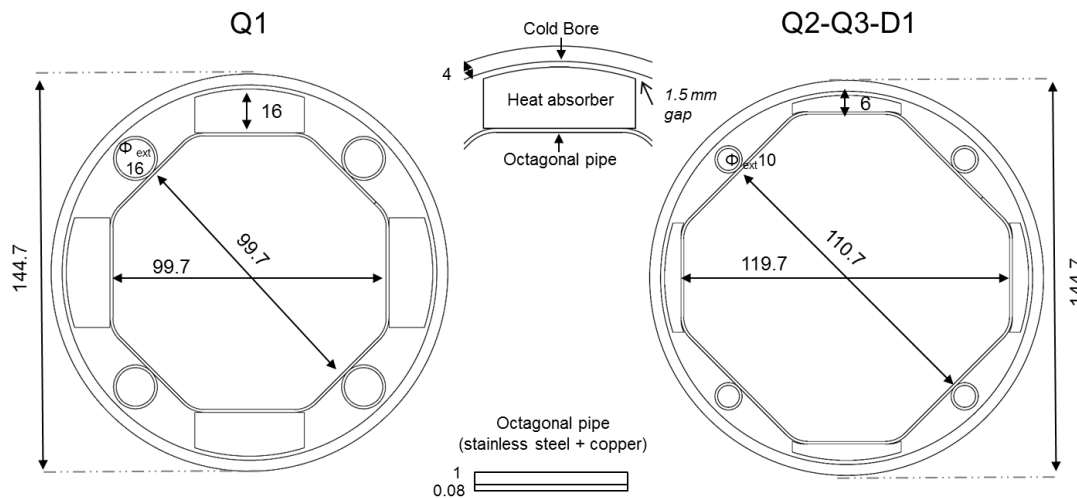

*The dimensions are given in mm

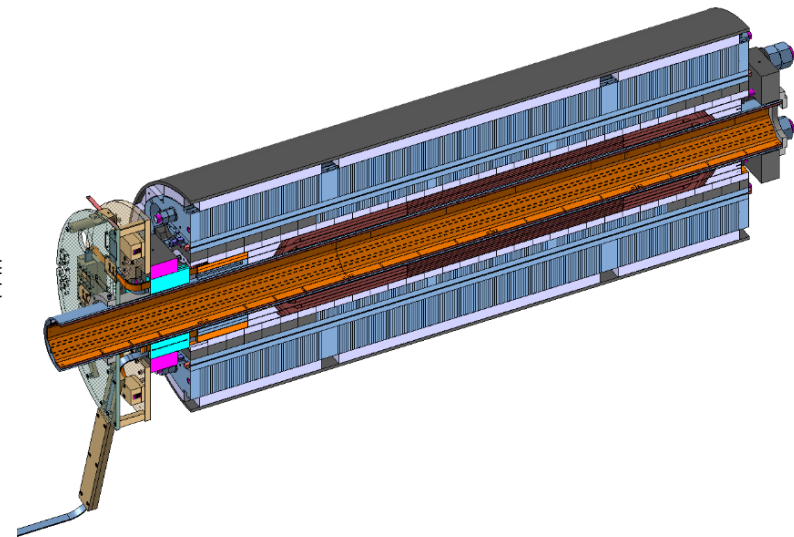

Test of cold bore tube and beam screen

- Radial displacement of the cold bore caused by the Q1 beam screen : **1.5 mm**
- A **33 % reduction** of forces is estimated by considering the “electro-magnetics dynamics” of the coil

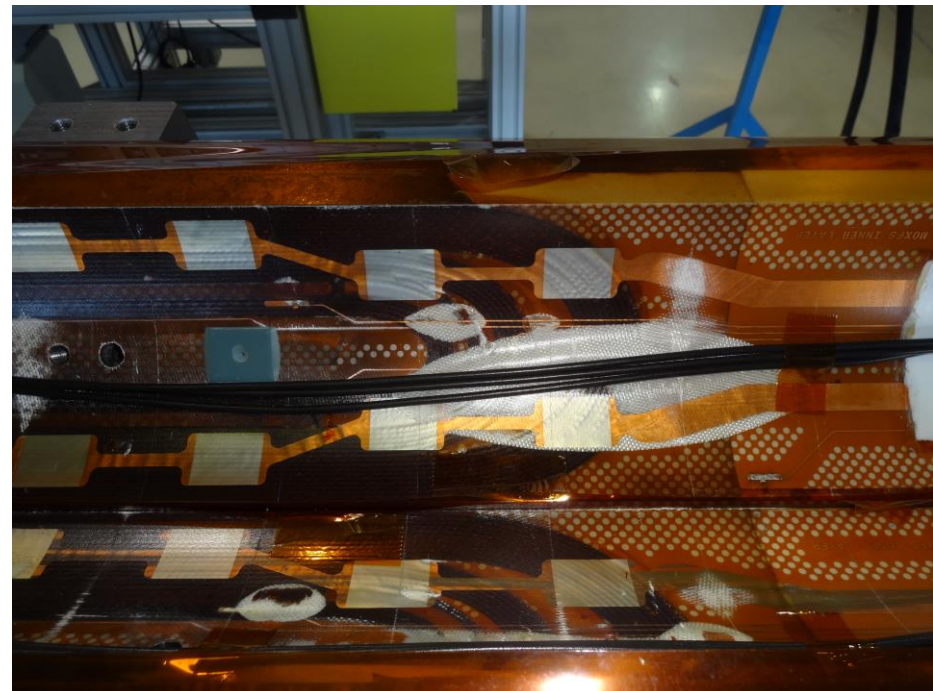
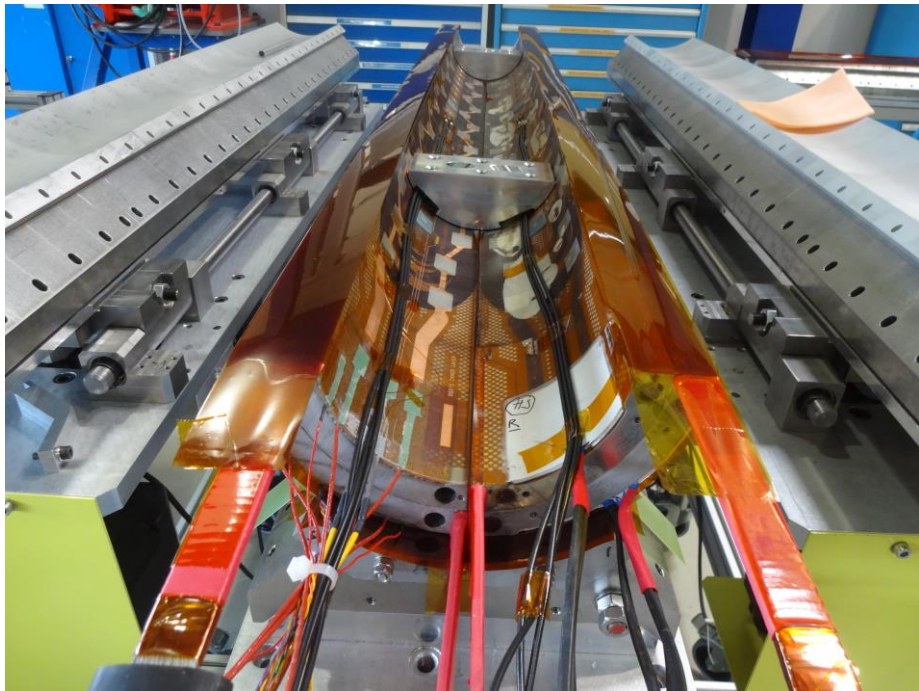

Test of new inner layer trace

- Outcome from MQXFS3 and MQXFS5
 - Bubbles associated to weak bonding epoxy-metal
 - Also if QH not fired
- On going R&D
 - Encapsulated trace (polyimide cover layer pressed)
 - Surface treatment of metal parts
 - sample 1: *inversion sulfurique*
 - sample 2: *abrasion mécanique*
 - sample 3: *deposit of thin layer of Polyuréthane on ss*
 - sample 4: *Cleaning of ss (with Acide Fluoridrique)*
 - sample 5: *Laisser le Ni de wood*
 - sample 6: *no treatment*

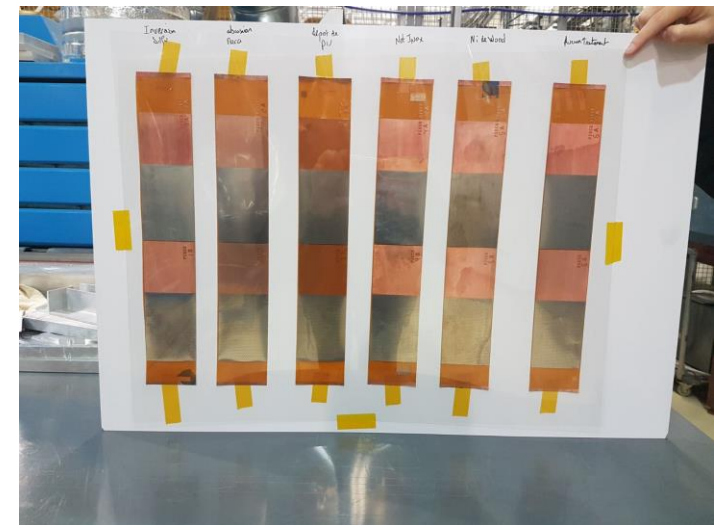
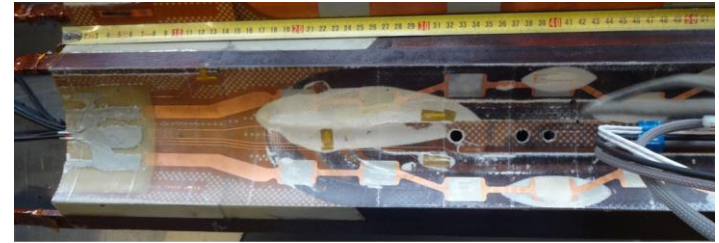

Test of new inner layer trace

- Test in MQXF4
 - Coil 108: standard trace,
 - Coil 109: No inner layer trace
 - Coil 110: encapsulated trace
 - Coil 111: surface treated trace
- Results in summer 2018
 - First set of series QH must be standard

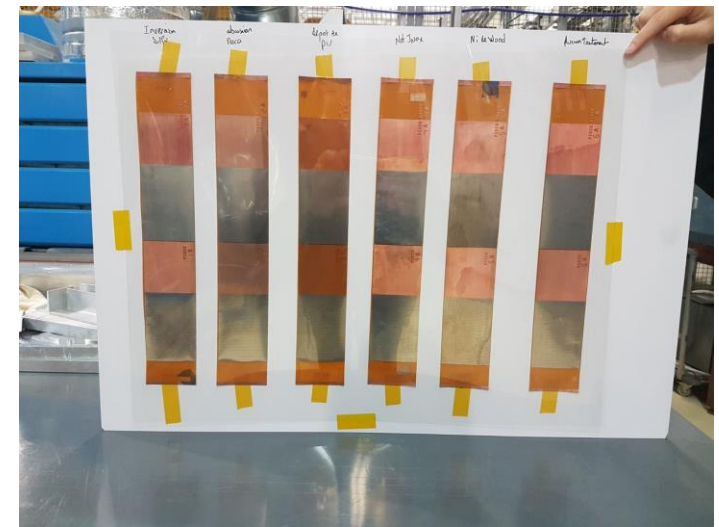
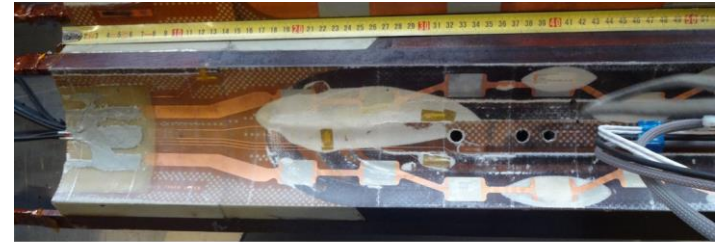

Outline

- Short models
- Prototypes
- Overview of series production

LARP prototype program

Coil fabrication

- Coils for practice & mirror: **2** coil, 4-m long, completed
 - Coil 01 for mirror (1st generation cable)
 - Coil 01b practice (1st generation cable)
- Coils for MQXFAP1: **4** coils, 4-m long, completed

- Coils for MQXFAP2
 - 101 to 106 (FNAL and BNL)
- Coil for MQXFA3
 - From 107 (FNAL) and from 201 (BNL)

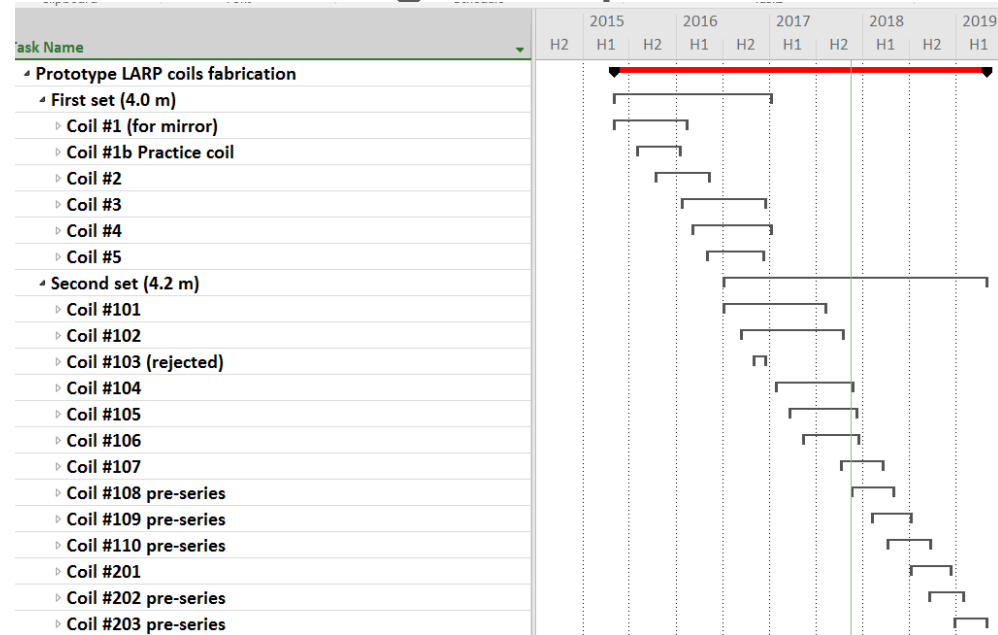

LARP prototype program

Prototype plans

- **MQXFAP1** (4 m long)
 - Test in summer 2017 with coils 02,03,04,05
- **MQXFAP2** (4.2 m long)
 - Test in by mid-2019 with 101,102,104,105
- **LQXFAP** (prototype cold mass)
 - Test in by early 2020 with MQXFAP1 and MQXFAP2
- MQXFA3 will be first series magnet

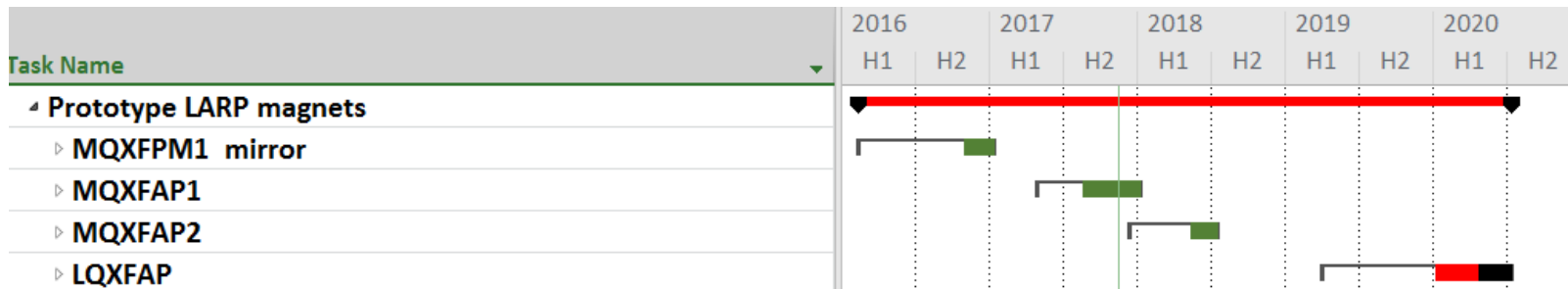

LARP prototype program (MQXFAP1)



CERN prototype program

Coil fabrication

- 1 coil with Cu cable and 2 with low grade Nb₃Sn completed
- 1st and 4th prototype coils (103 and 106) rejected for major NC
- New 1st and 2nd prototype coils (104 and 105) ready for reaction
- The 3rd (107) ready for winding
- In total, 5 RRP and 6 PIT coils to be produced

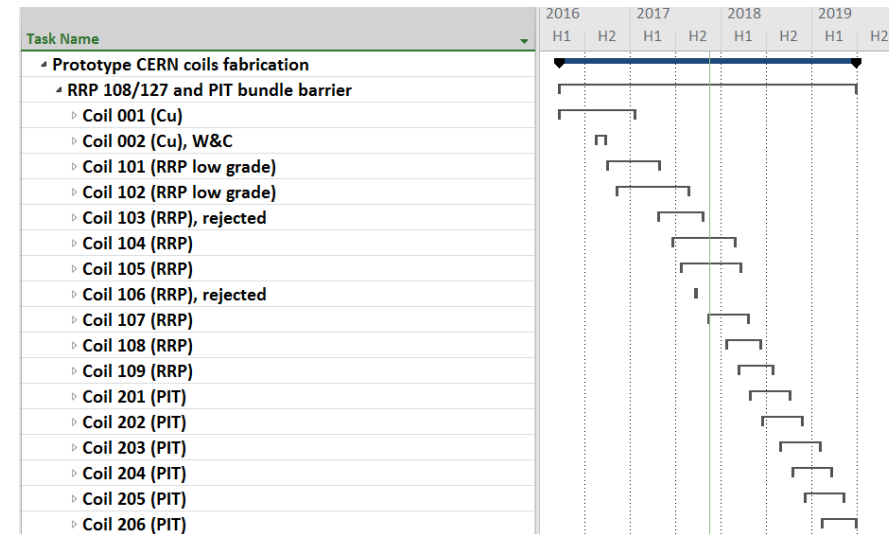

Rejected coils (Non conformities)

- Coil 103
 - Leads clamped during HT by a tool to prevent twisting

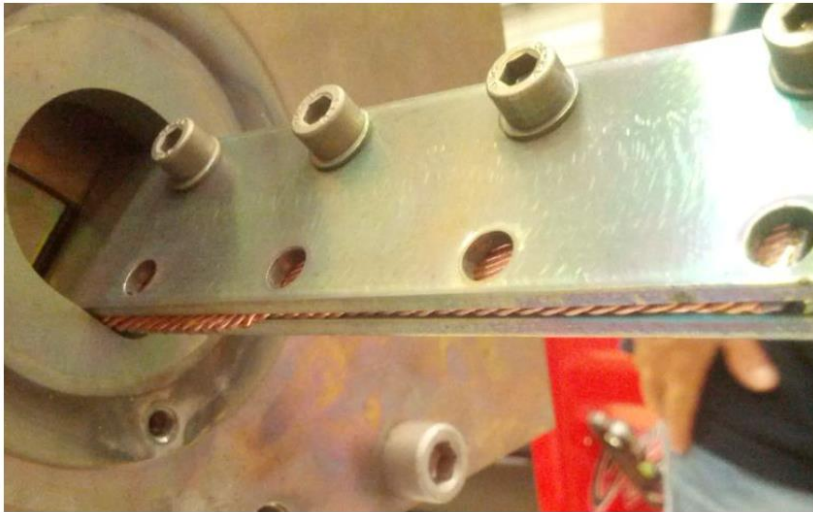

- Coil 106
 - Error in communication
 - 2nd layer cable length assigned to the spool for the 1st winding, and viceversa

CERN prototype program

Prototype plans

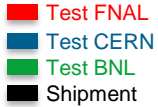

- Assembly structure started
- 4 practice coils available
 - 001,101,102,103
- MQXFB mech. test
 - Goal: full loading
- MQXFBP1
 - Test in May 2019
 - *Proposal: test of MQXFBP1b with beam screen*
- MQXFBP2
 - Test in Feb. 2020

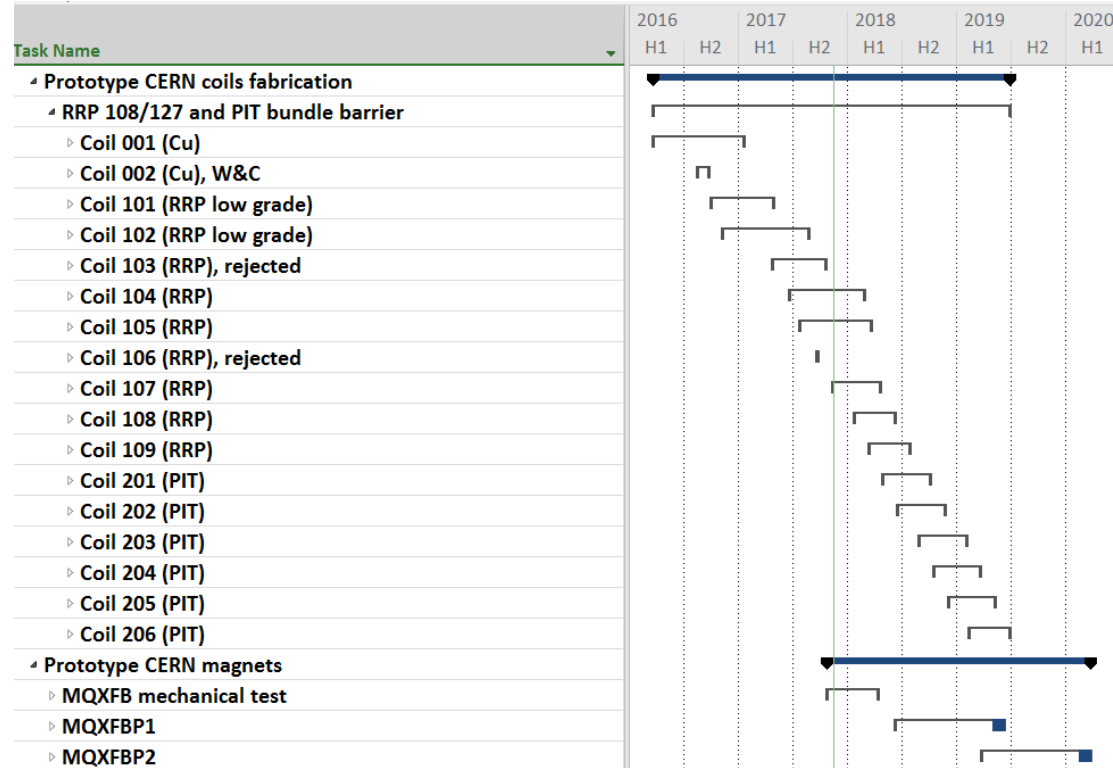

- Under investigation
 - Vertical test at CEA ?

CERN prototype program



Outline

- Short models
- Prototypes
- Overview of series production

Overview of MQXF series

