

Current progress on Offline 2 and the RFQcb.

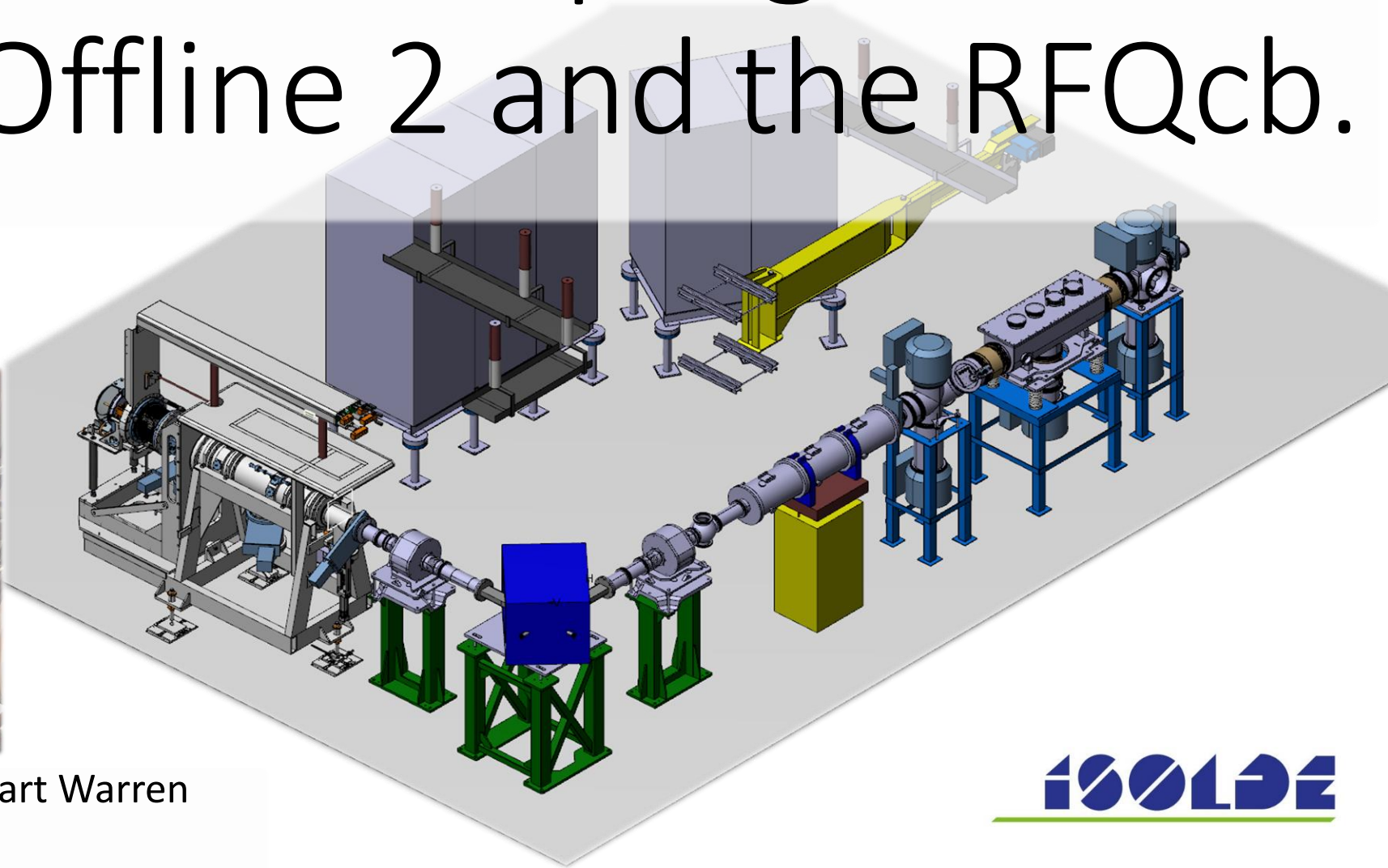
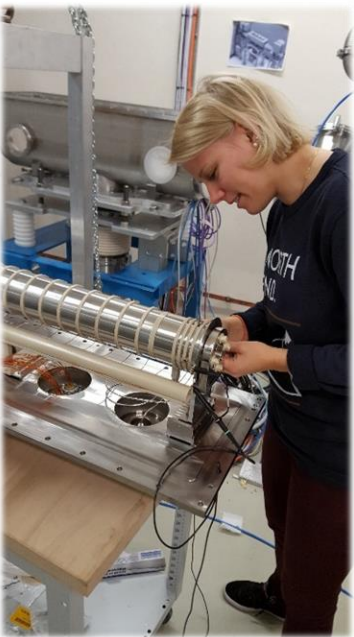

Presented by Stuart Warren
EN-STI-RBS

ISOLDE

What is Offline 2 and why do we need it?

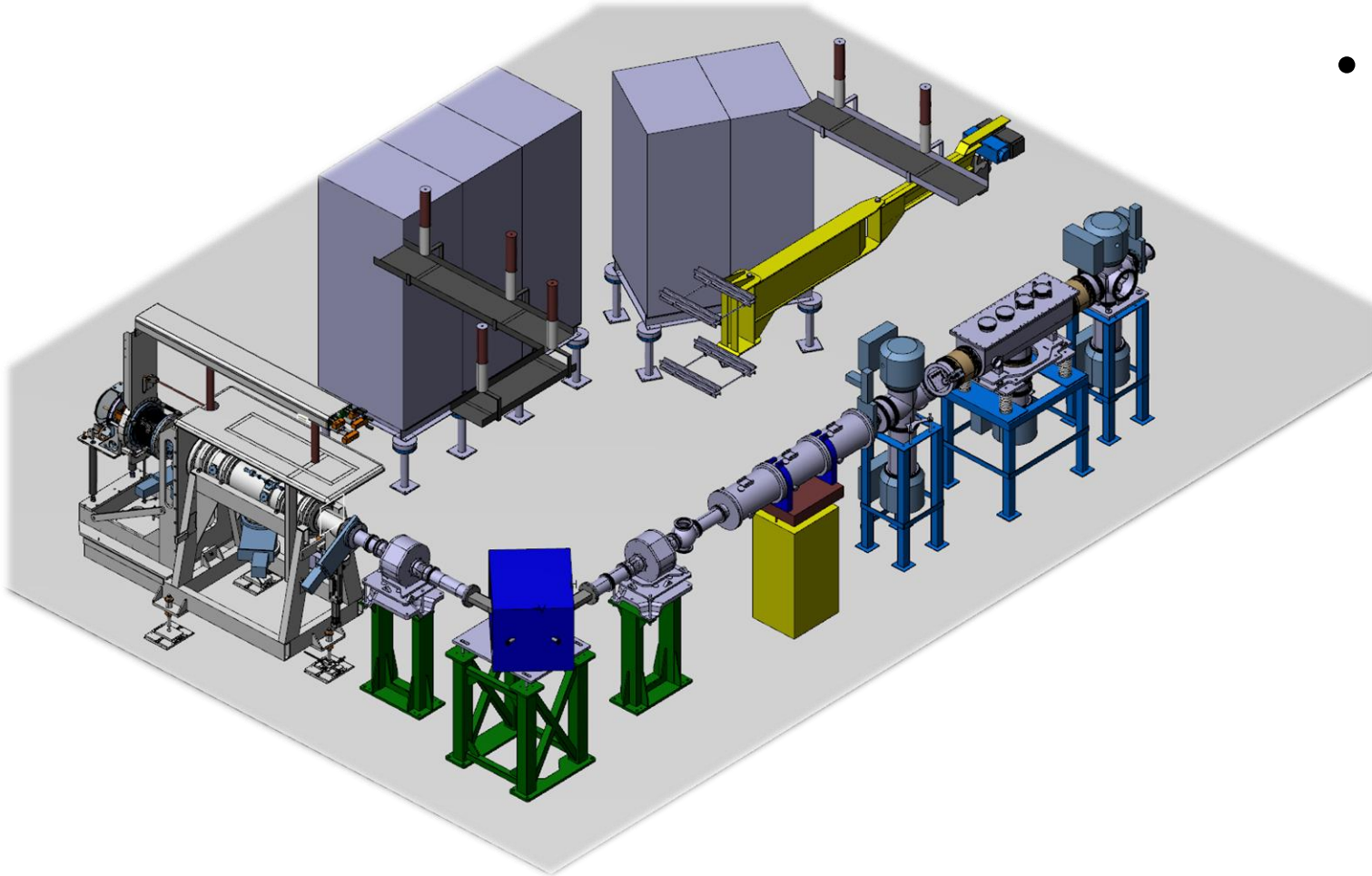

Good Question!

- Dedicated test facility
 - target testing
 - Ion source development
 - Beam techniques
 - Beam optics detector development
 - Time Of Flight (TOF) detector development
 - **RadioFrequency Quadrupole cooler buncher (RFQcb) development**
 - Beam quality

What is quality? subjective

- It depends on who you ask
 - ISTRAP – want cooled bunched beams with low energy spread
 - CRISS – want narrow bunched beams
 - Low isobaric contaminants
- Good transport properties
 - Narrow beam diameter (x,y)
 - Low transverse emittance (x,a) (y, b)
- Low energy spread
 - Small longitude emittance (E,t)
- Easily controlled and predictable system for users
- Without good beam quality intensity becomes pointless

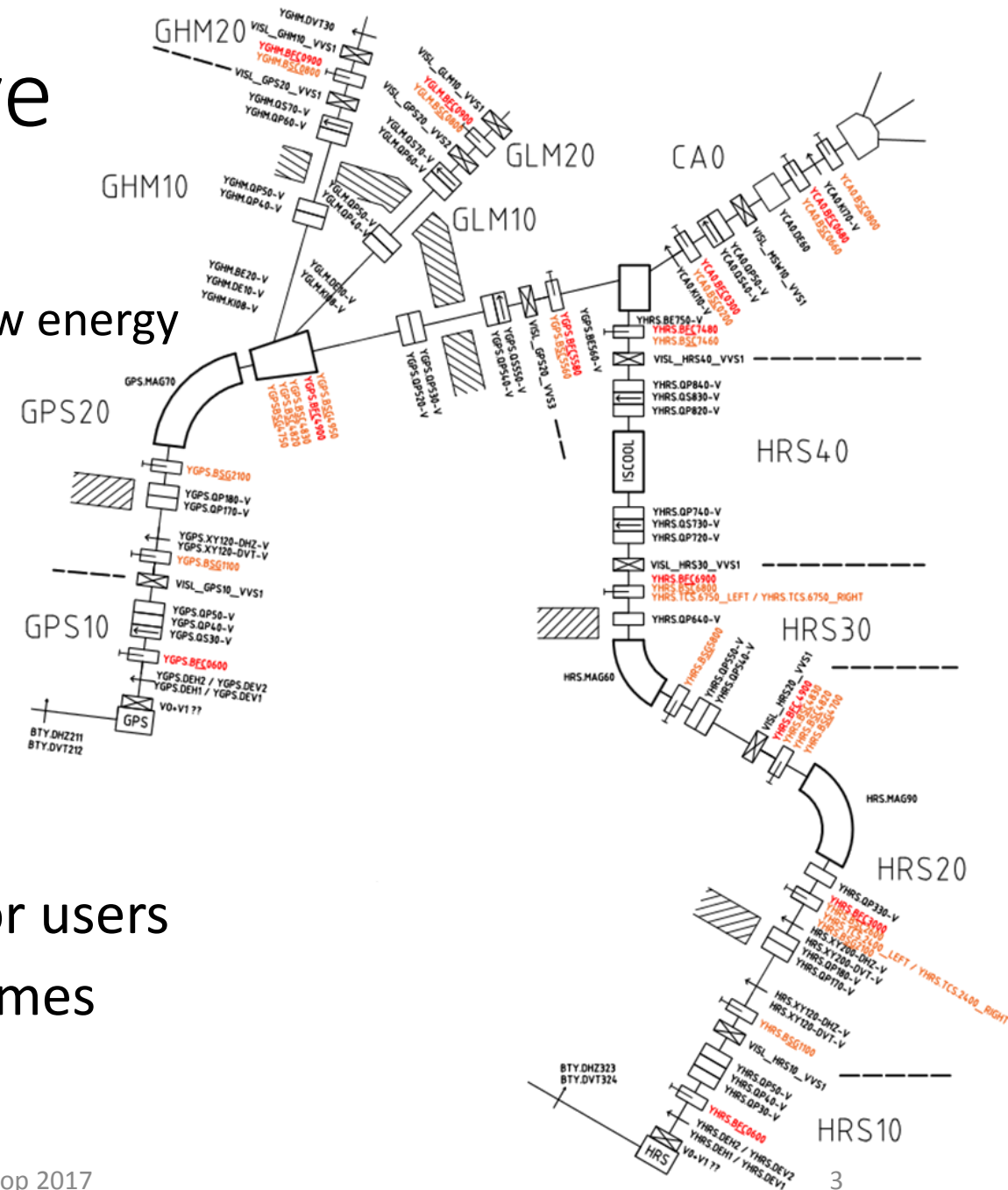

What is beam emittance

- Emittance can be defined as an evaluation of the beam quality

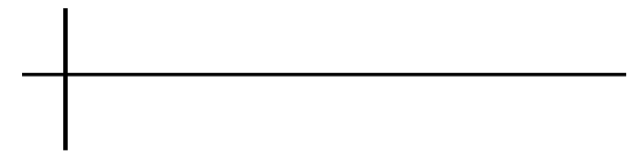
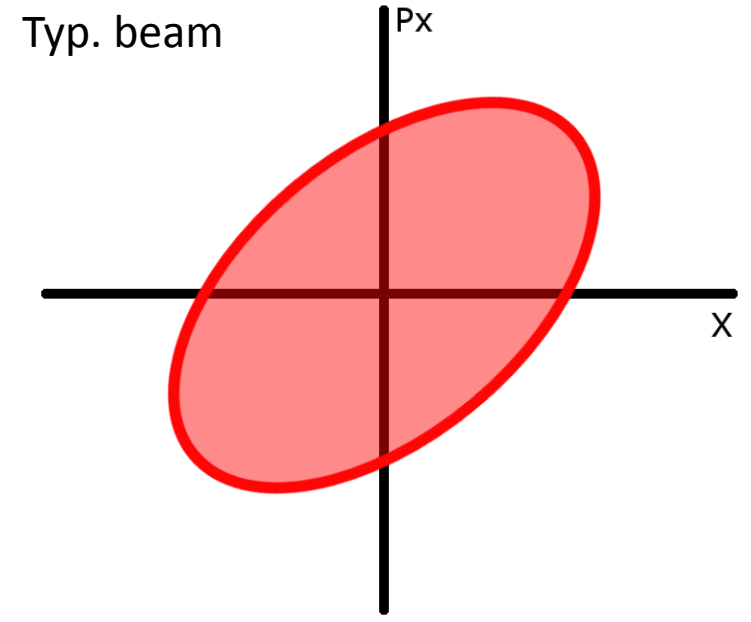
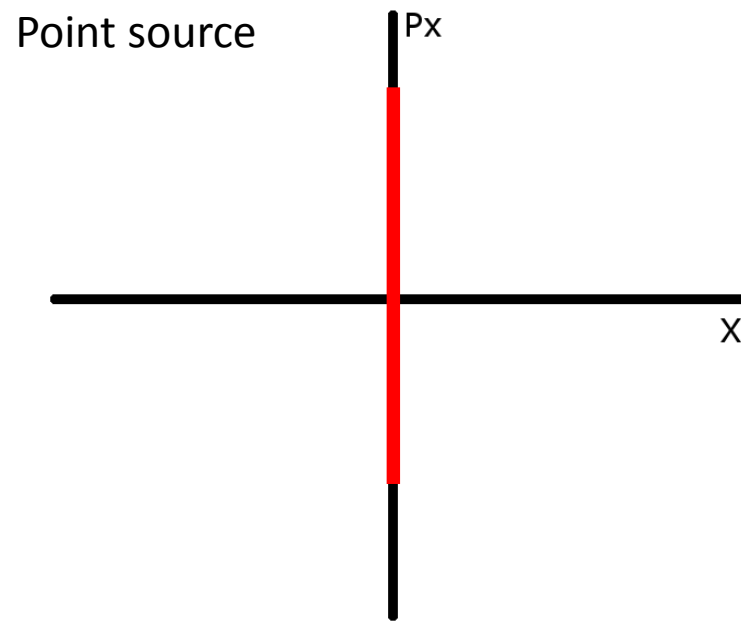
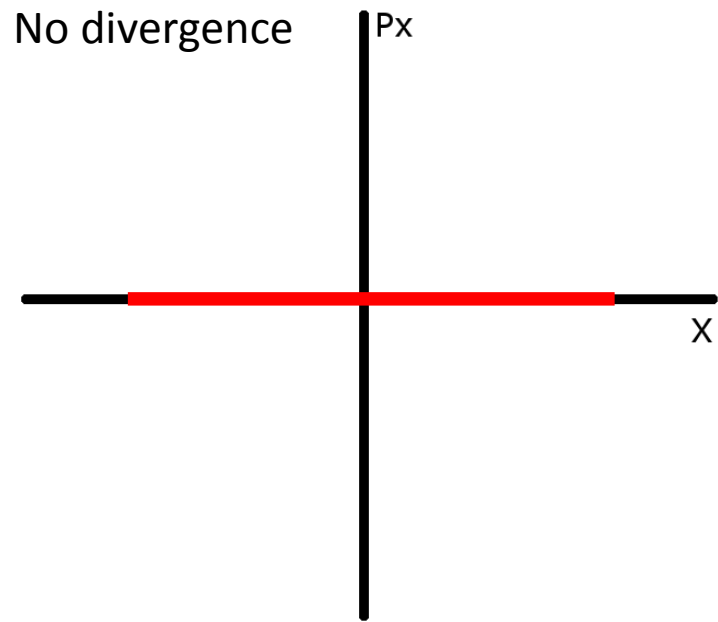

Transport

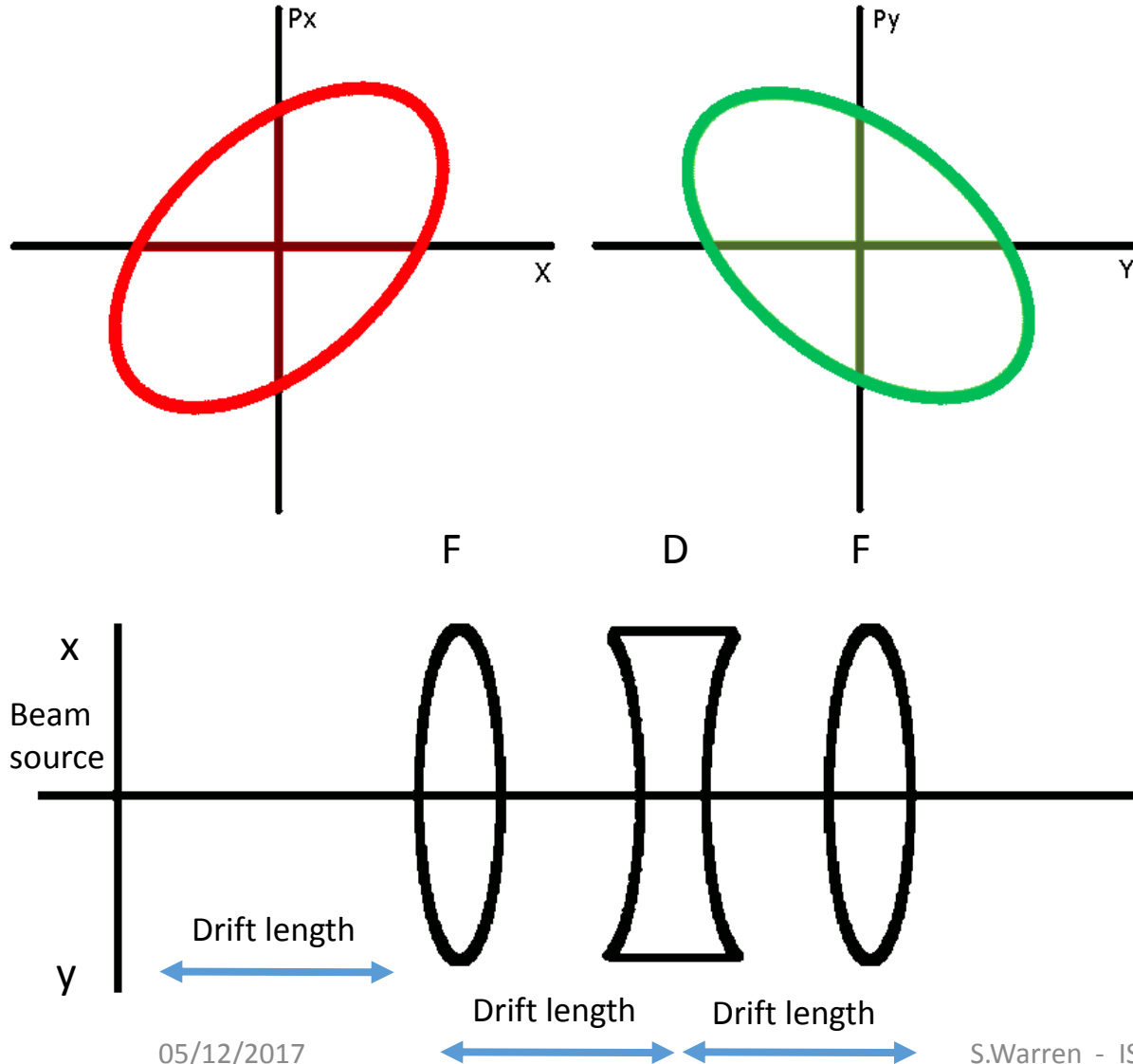

- Refocusing the beam with Quadrupoles
 - Focuses one plane while defocusing the other
- Emittance is the area of the ellipse in phase space
$$\int dx' dx = \pi \varepsilon$$

$\varepsilon =$ beam emittance
- Emittance always the same!!
 - Can change through beam energy loss/gain

What is ISCOOL

- Located on HRS line, improved beam transmittance at CA0
- Linear gas ion Paul trap with cooling buffer gas.
- Cooling drives the ions to the center of the trap:
 - increasing ion density
 - Reduces dopplar broadening
 - Improves mass measurements
 - Improves spectroscopy measurements
 - etc. etc.
- Offline testing 2006, installed 2008, repaired and renovation 2012

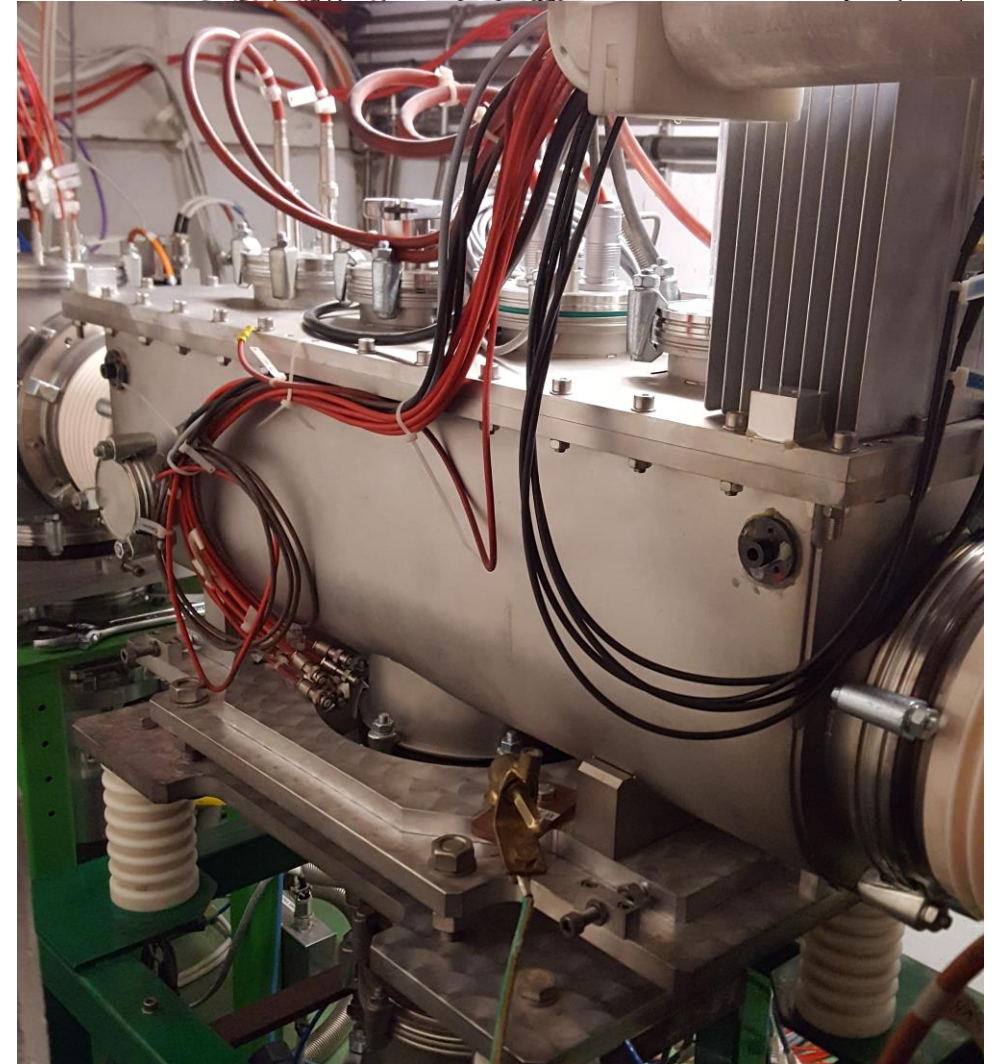

Why are we talking about it

- We have seen the RFQcb (ISCOOL) significantly improves the beam quality for the HRS
 - Narrower beams (laser overlap, transport, better for experiments)
- BUT only quantifiable data on the RFQcb is dated and limited
- In situ it is not possible to test and improve many of the desirable traits (emittance, bunching emittance)
- Working towards a simulation of the entire system for investigation non measurable quantities
- **BOTTOM LINE** not enough space and time to investigate thoroughly online

Ok but what is it?

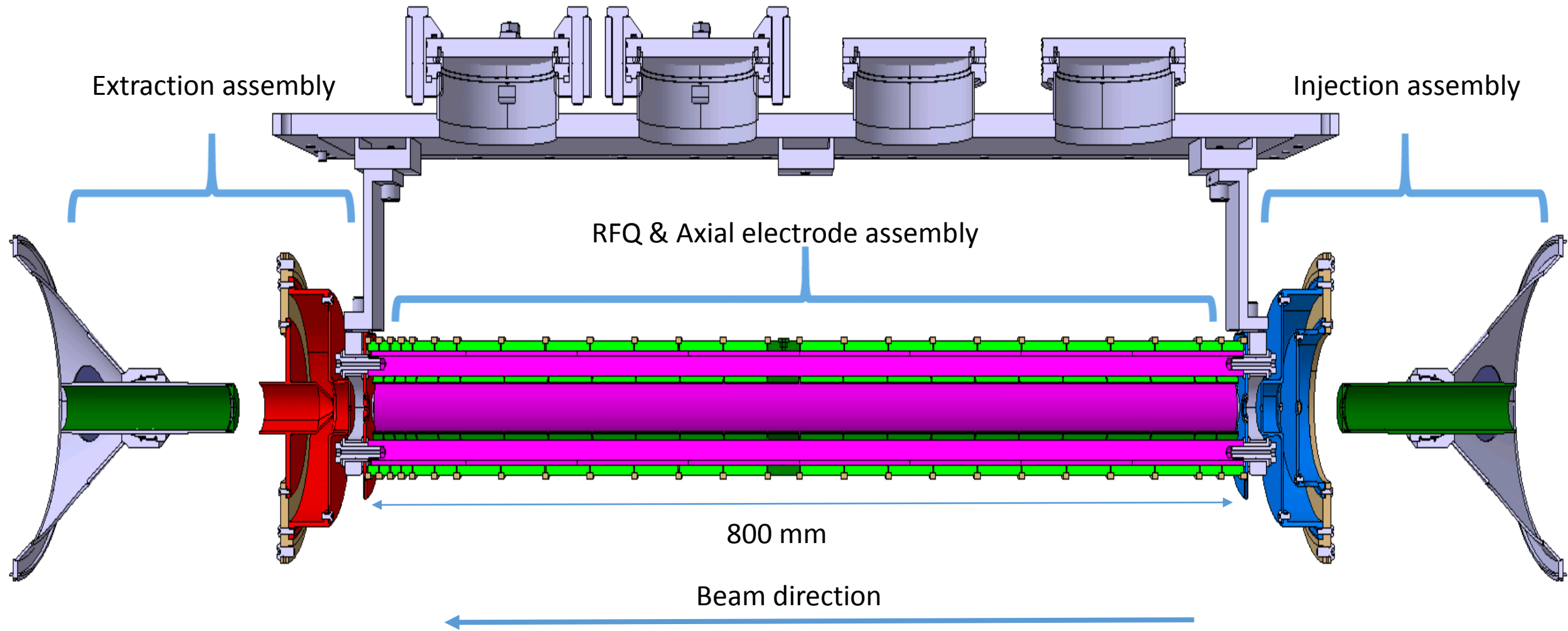

Injection assembly

- The entire RFQcb is typically at a potential just below the beam Energy e.g. 50 kV

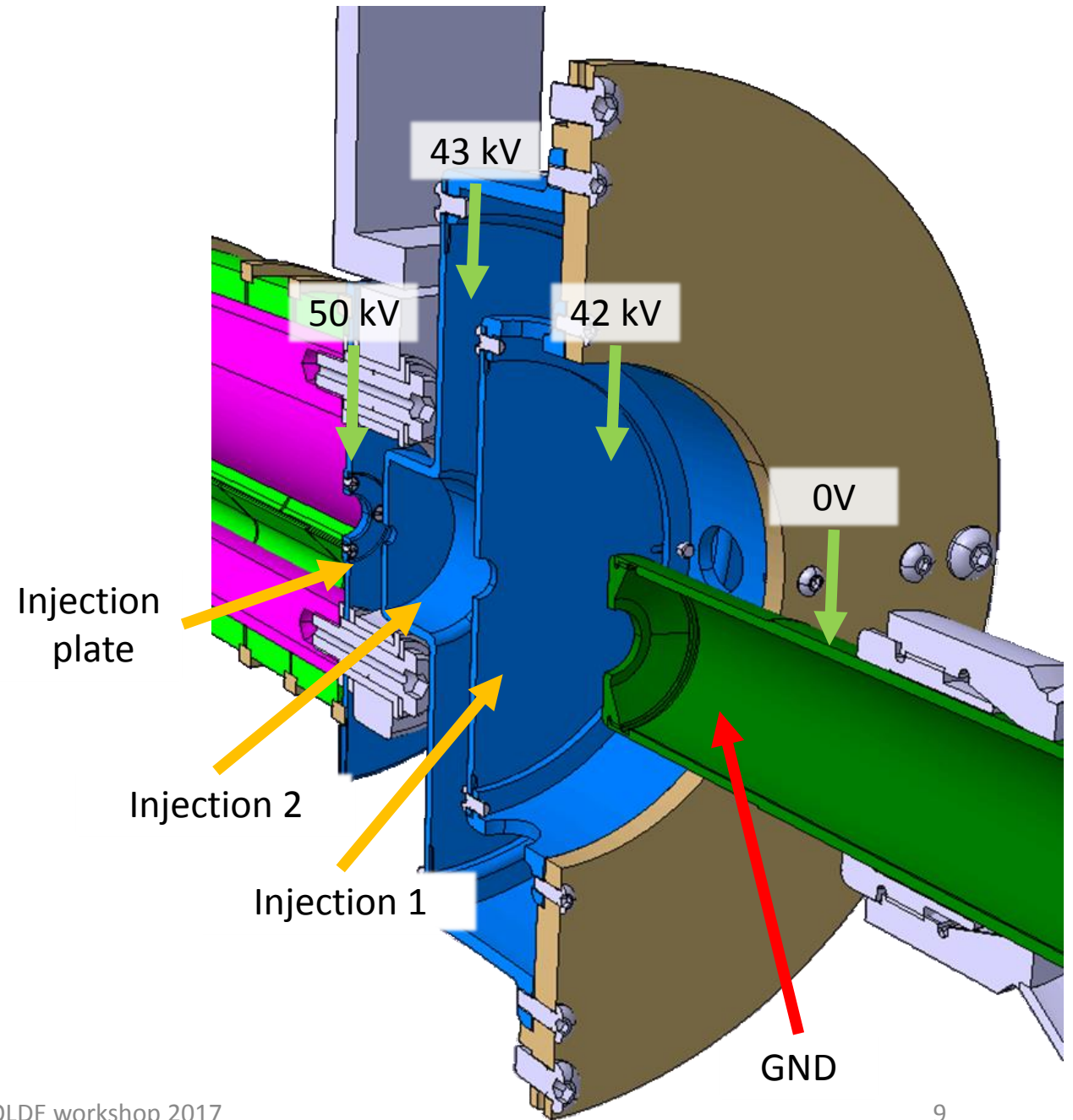
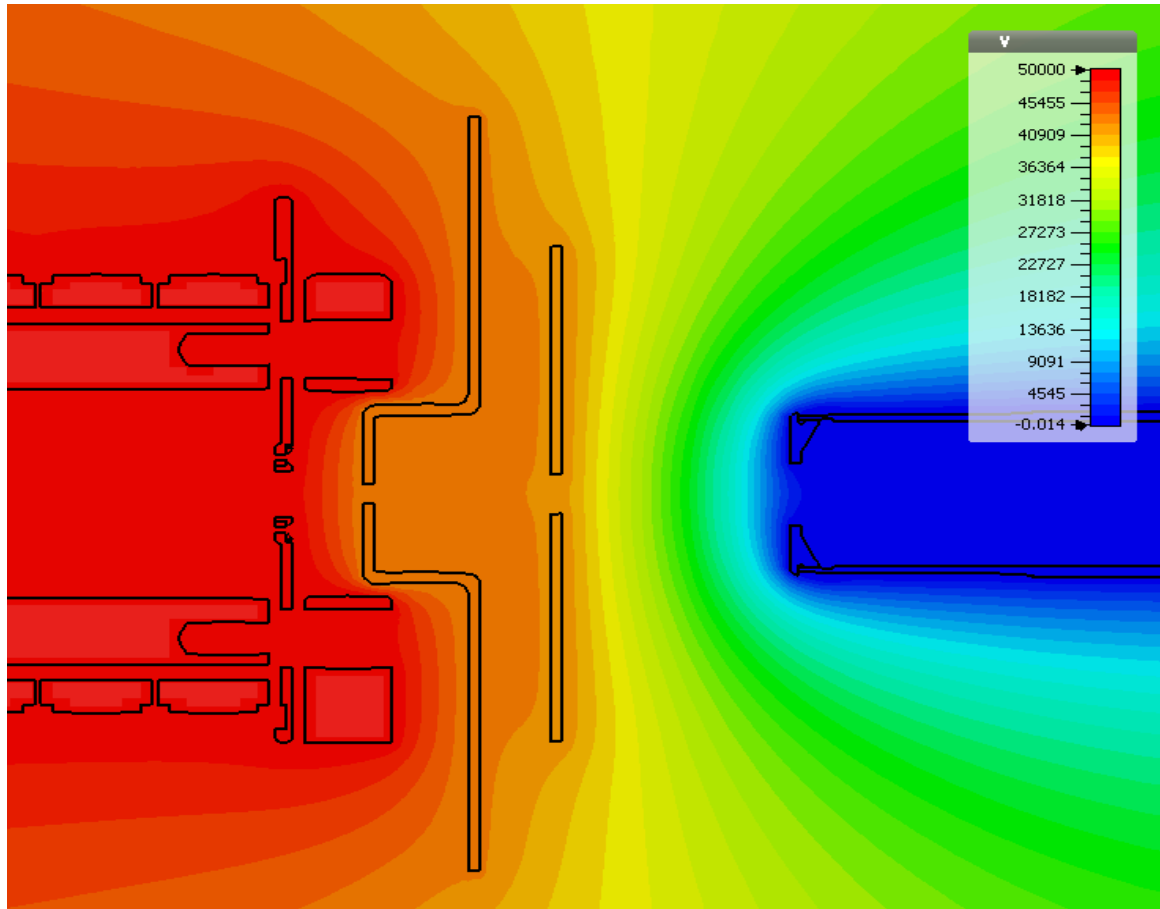

- Beam injection with:

- E= 50 keV
- RFQplt pot = 49.85 kV
- Typical beam
 - $\epsilon = 25 \pi$.mm.mRad
 - $\Delta E = 10$ eV
 - $\varnothing = 4$ mm

- Beam 'explosion' – residual transverse momentum!!

- $a = \frac{P_x}{P_0}$ where P_0 is total momentum
- Emittance $\propto \sqrt{\frac{E_0}{E_t}}$

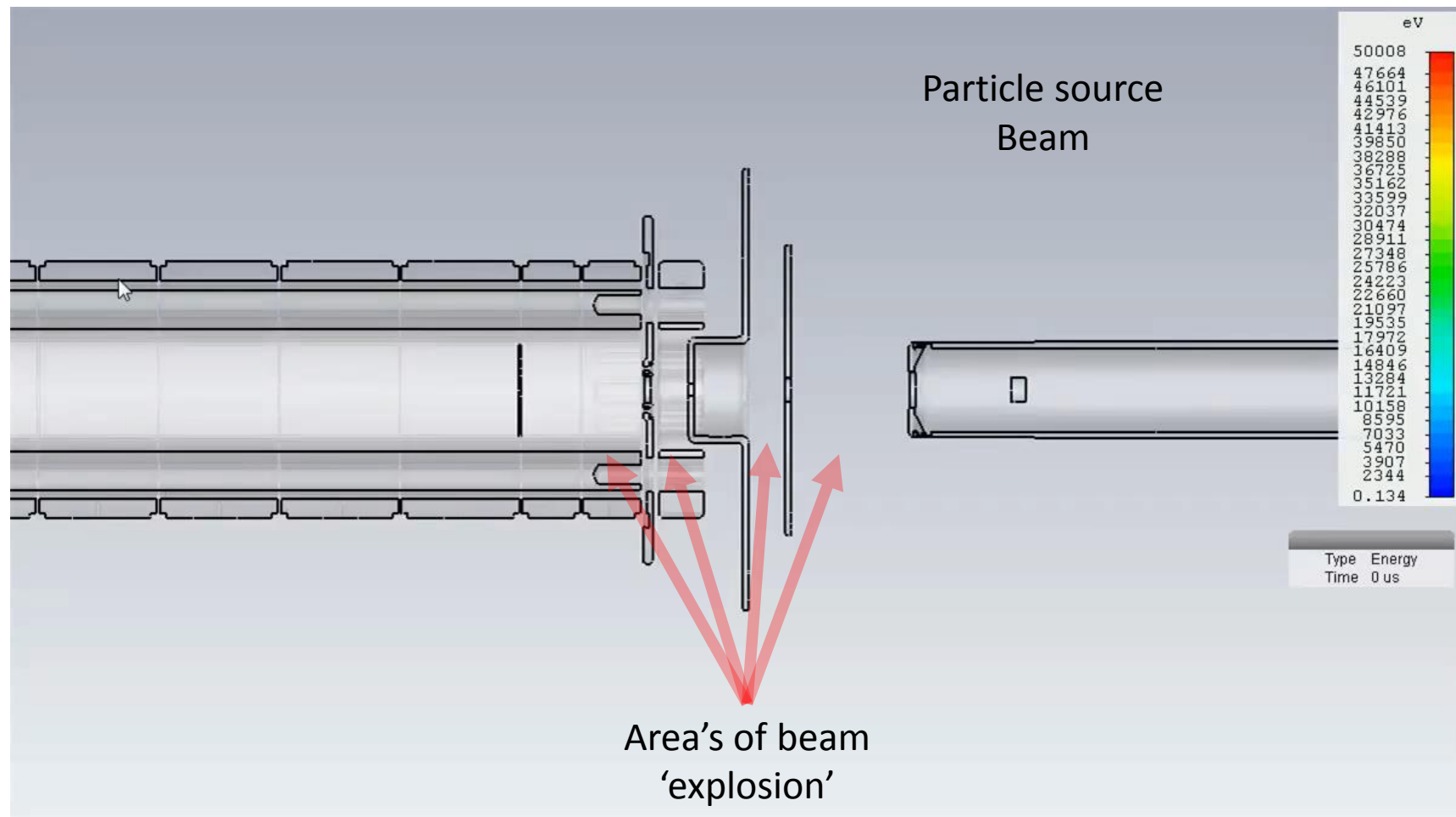

Unless properly optimized we expect losses here

RFQ & Axial electrode assembly

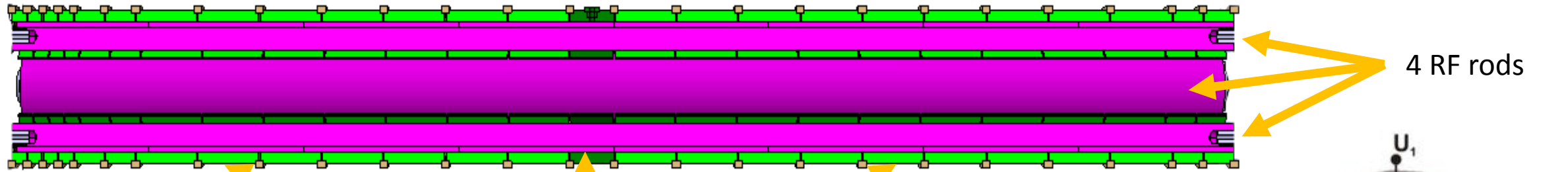

25 Axial electrodes

U1 180° out of phase of U2

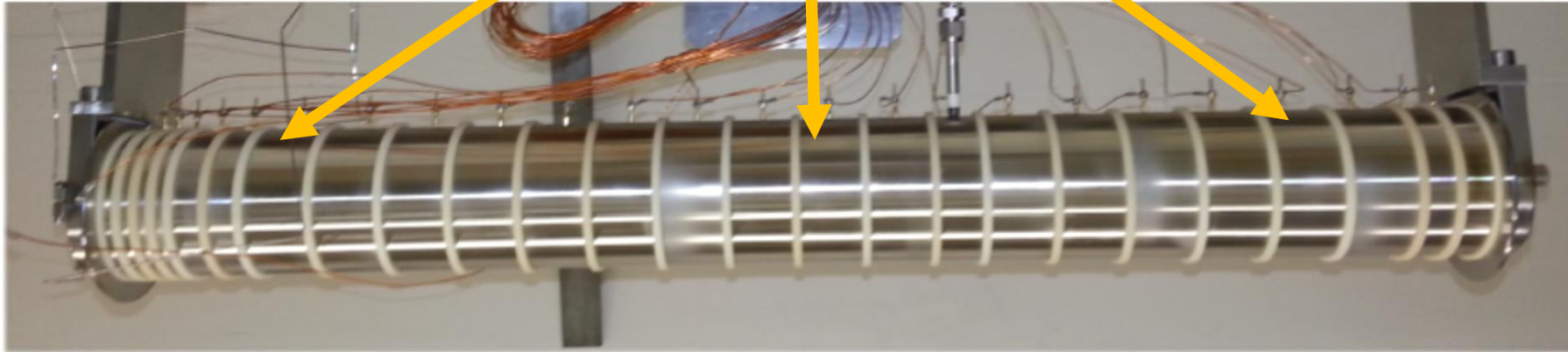
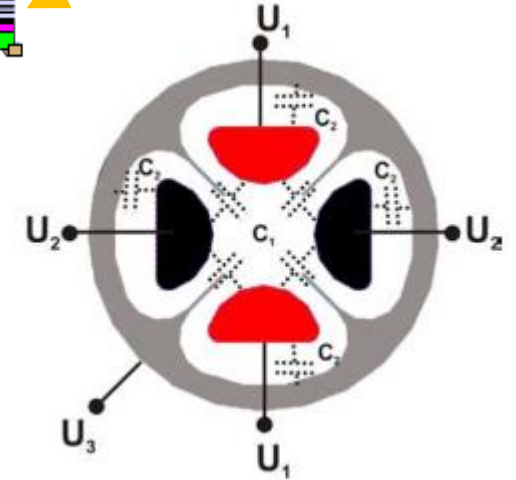

Beam direction

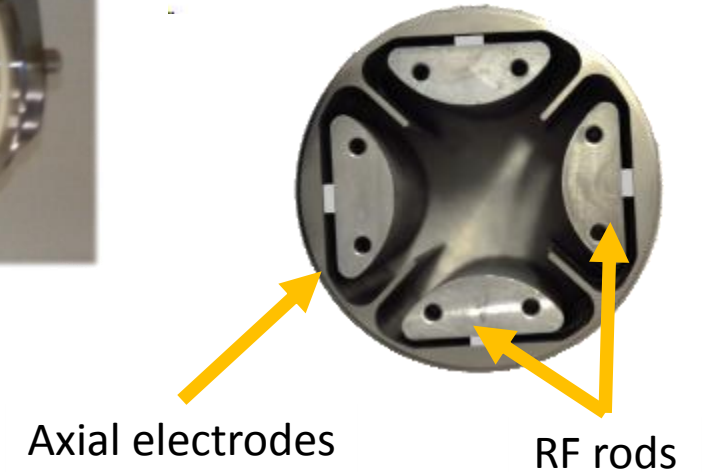

Radio-Frequency Quadrupole, RFQ

Collison's alter the trajectories of the ions, sometimes substantially of the optical axis.

The RF guides the ions back to the optical axis switching between Focus and Defocus rapidly 340 kHz

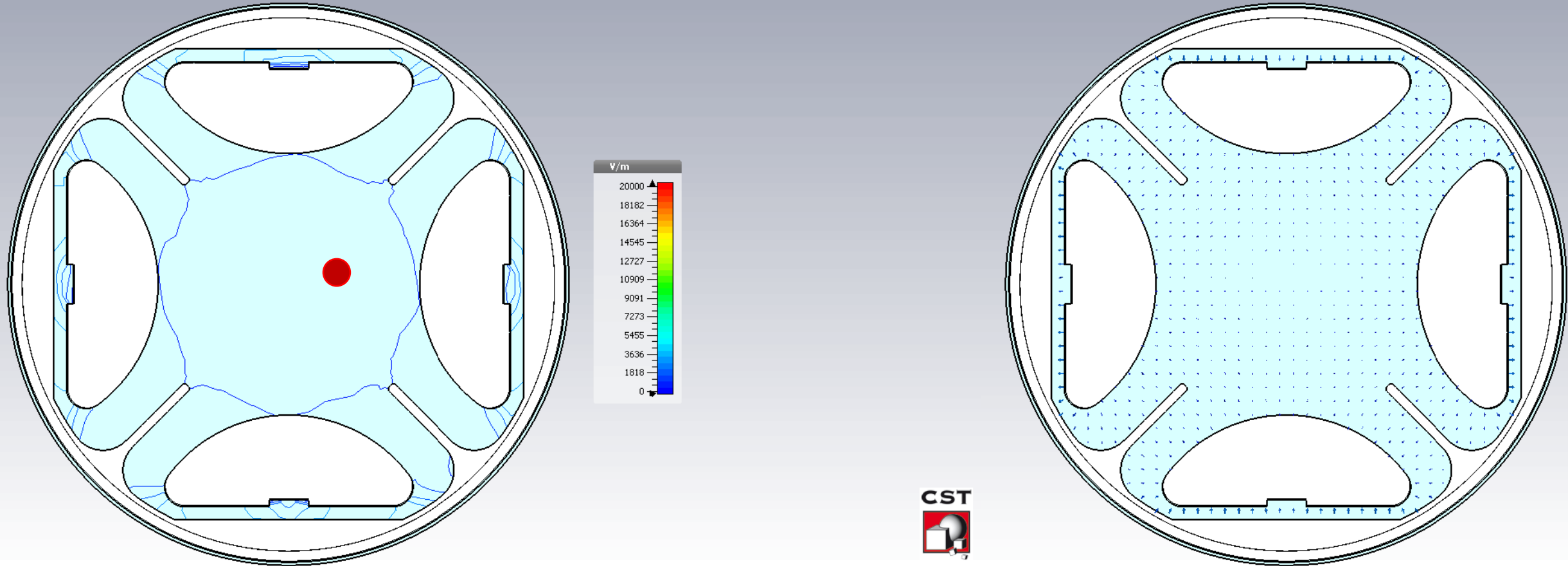

ISOCOOL

- Heavy ion collisions with light neutral He.
- Mass difference provides a small loss in KE
 - Trajectory not heavily effected through initial collisions
- Multiple collisions leads to ion scattering off beam axis
- Each collisions reduces total KE of ion until thermalized with gas
- Emittance improved from 25 to $3\pi. mm.mrad$

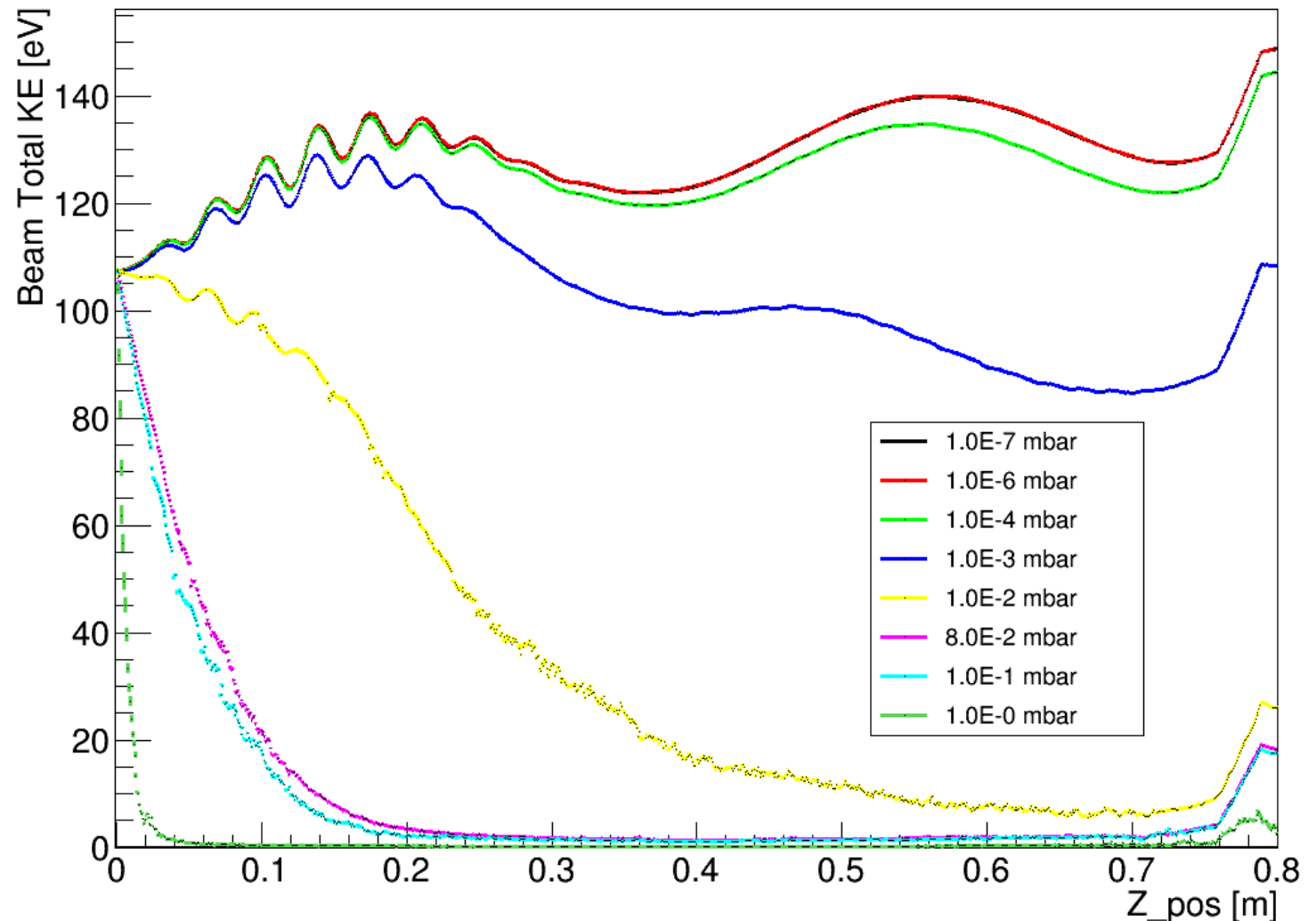

Graph of pressures and beam energy from C++ MC code written to simulate the RFQ

Beam current with gas in RFQcb

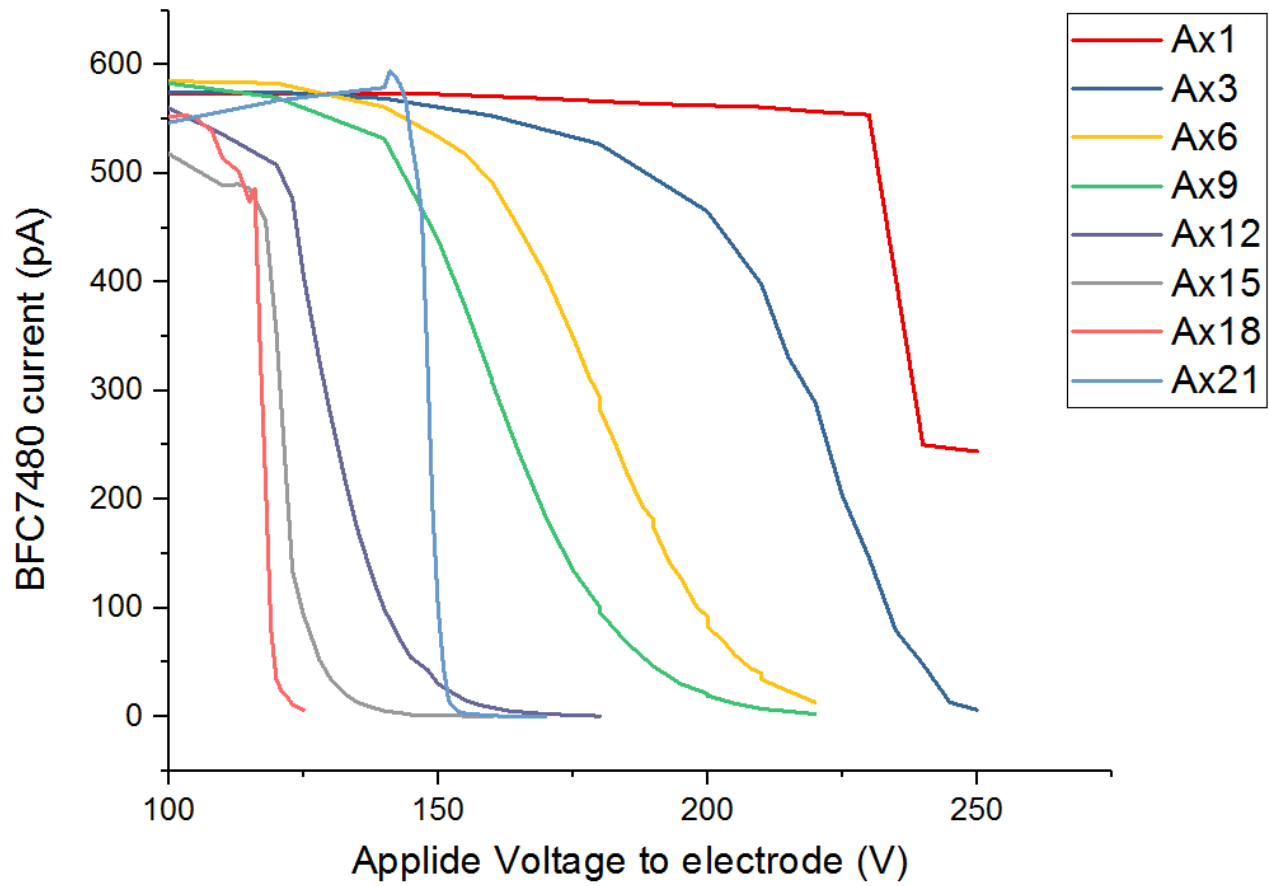

Beam current without gas in RFQcb

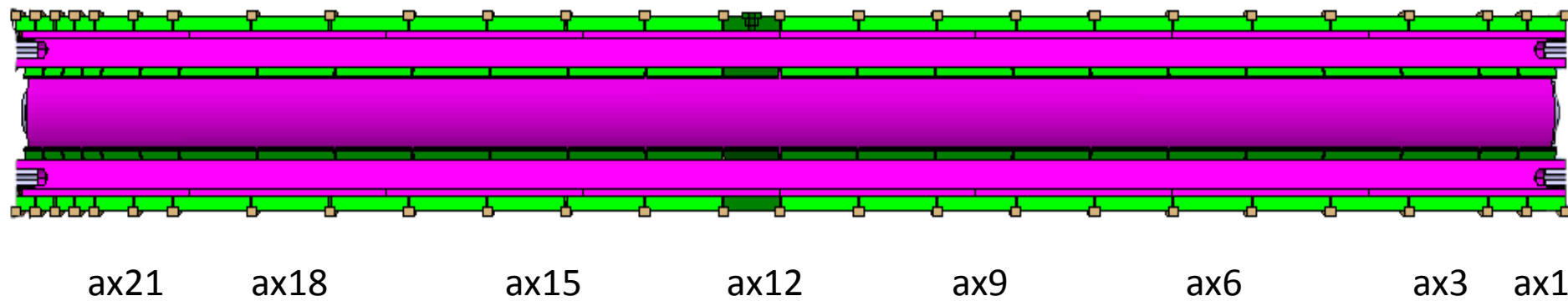
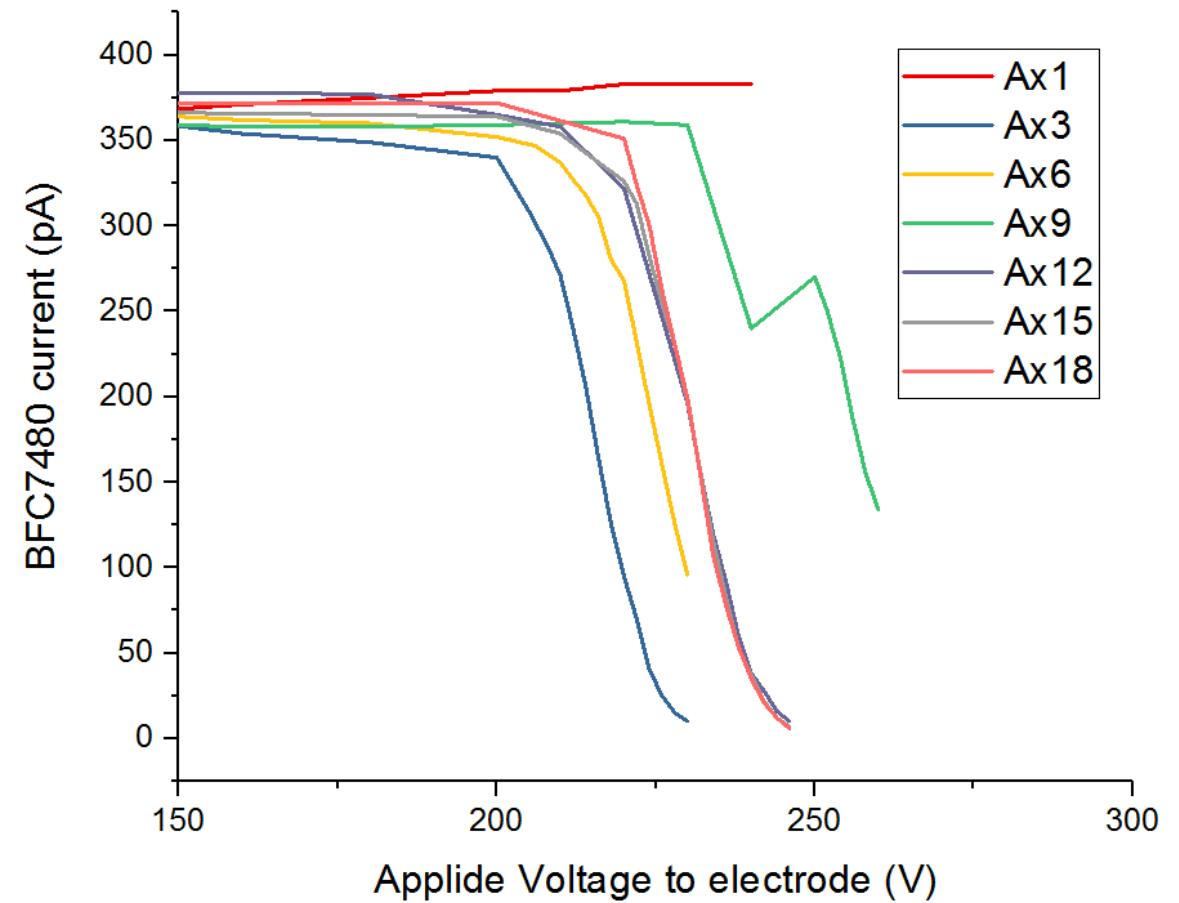

Trapping and bunching region

- Trapping of the cooled beam via axial potential
- 25 axial electrodes
 - 4 x 9mm trapping electrodes
 - 21 x guiding with 1 as a gas injector
- Trapping with potential gradient slope and gate
- Continuous mode has no gate and no gradient slope

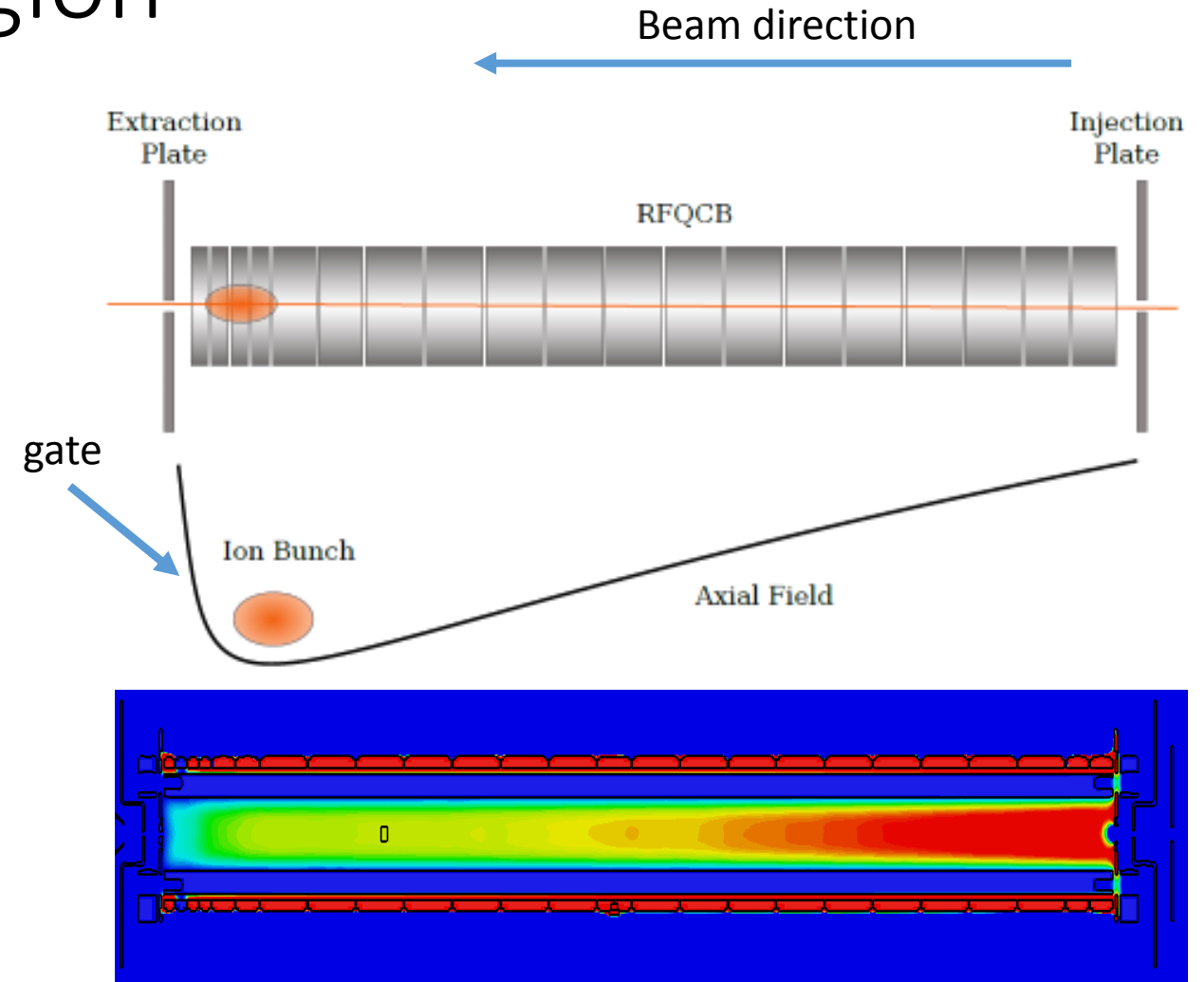

CST simulated potential along X central beam axis

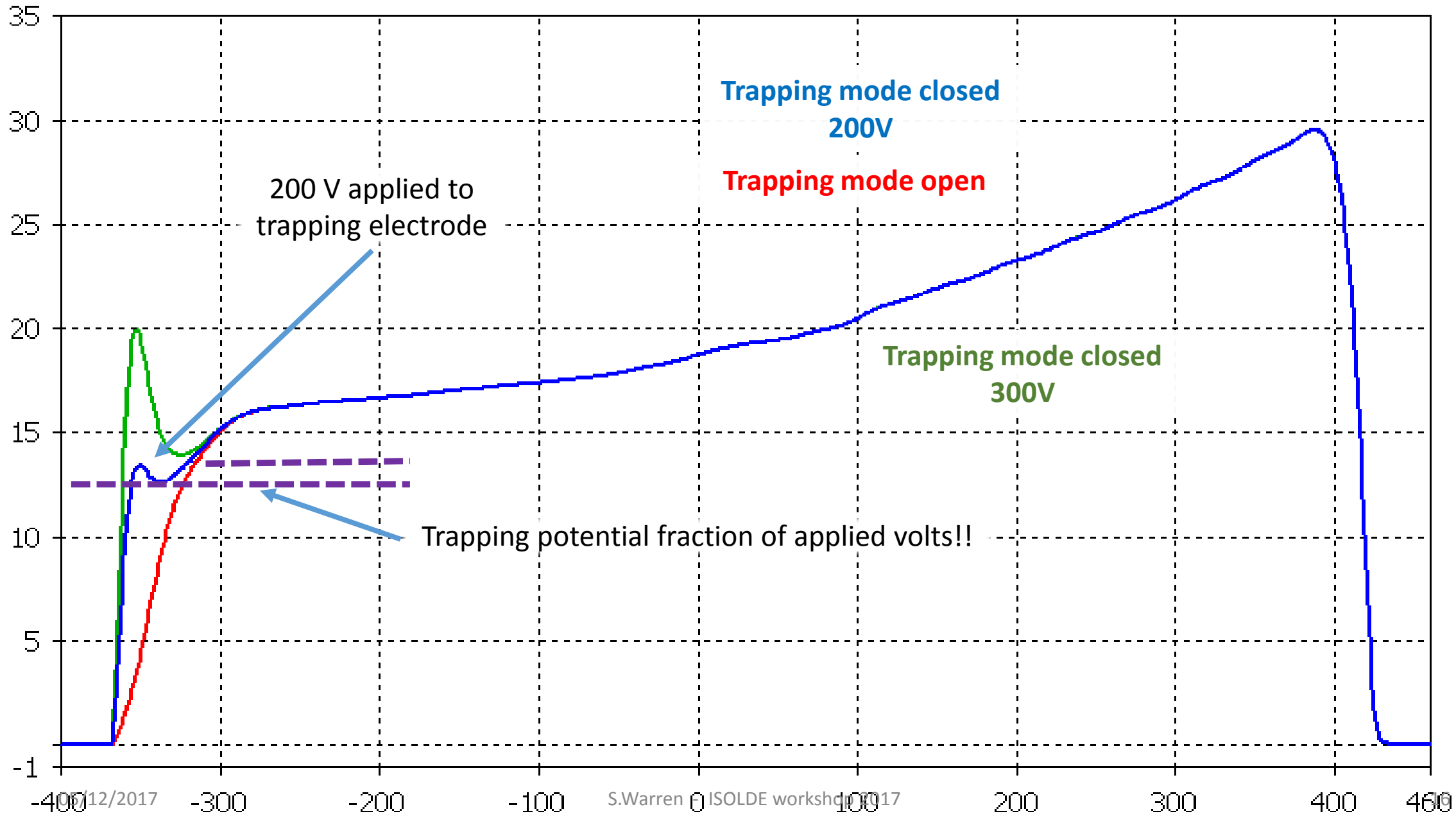

Summary

Simulations:

- Provided field maps for the RFQcb internal trapping potential
- Optimum RF values, pressure and potentials
- Provided better understanding of behaviour
 - Gas pressure throughout the RFQcb
 - Hinting towards better trapping methods

Simulations require validation

- Need to perform thorough investigations into
 - RFQcb internal pressure
 - Field values
 - Trapping methods
 - Emittance dependence on Pressure, RF, Potentials

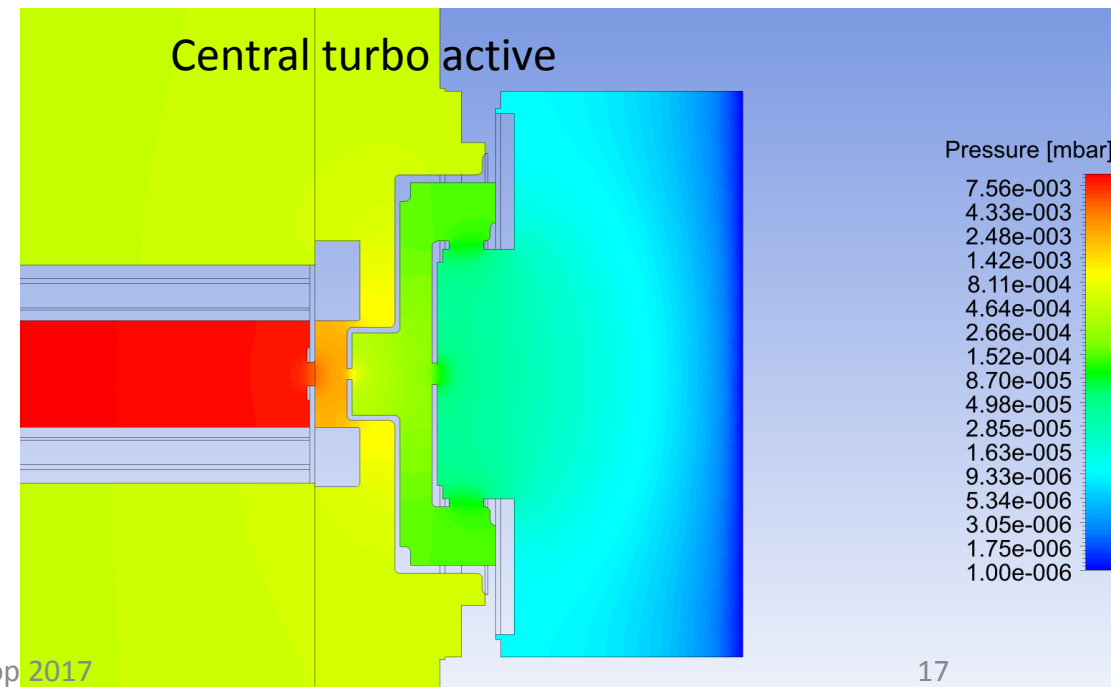
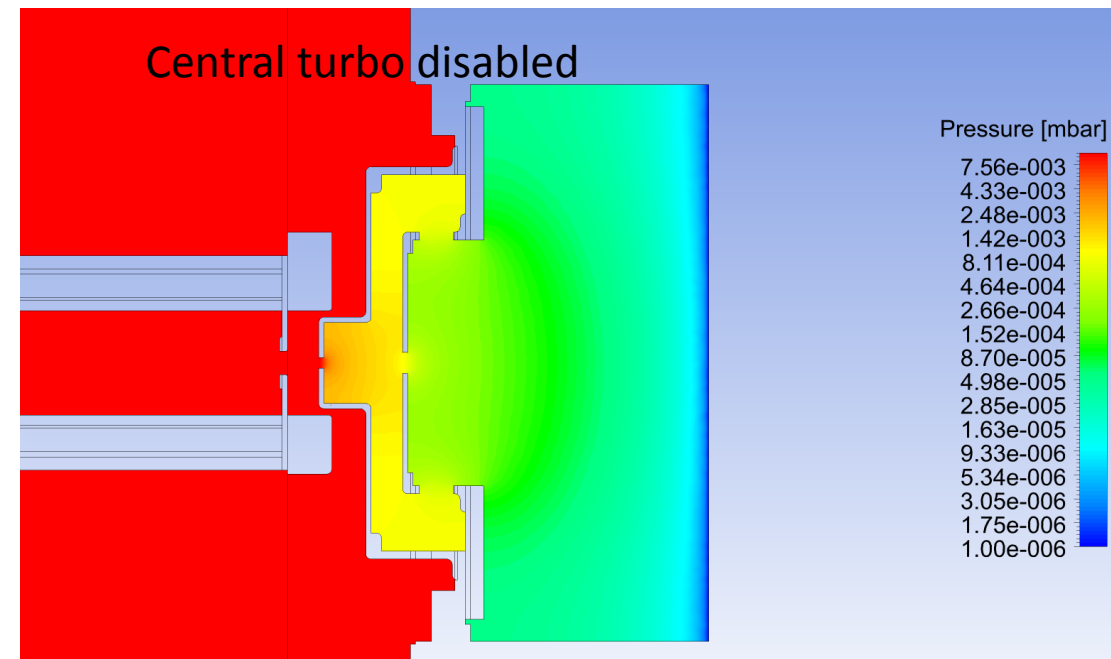

Offline 2

- Originally proposed 2013 but project was 'halted'
- New group assembled in summer 2016
- New room layout
- Services
 - Electricity needed to be installed
 - Cooling water circuits & air con
 - Compressed air
- New beam optics calculations
- Installation of the beam equipment 2017
- Beam line assembly summer 2017

05/12/2017

S.Warren - ISOL

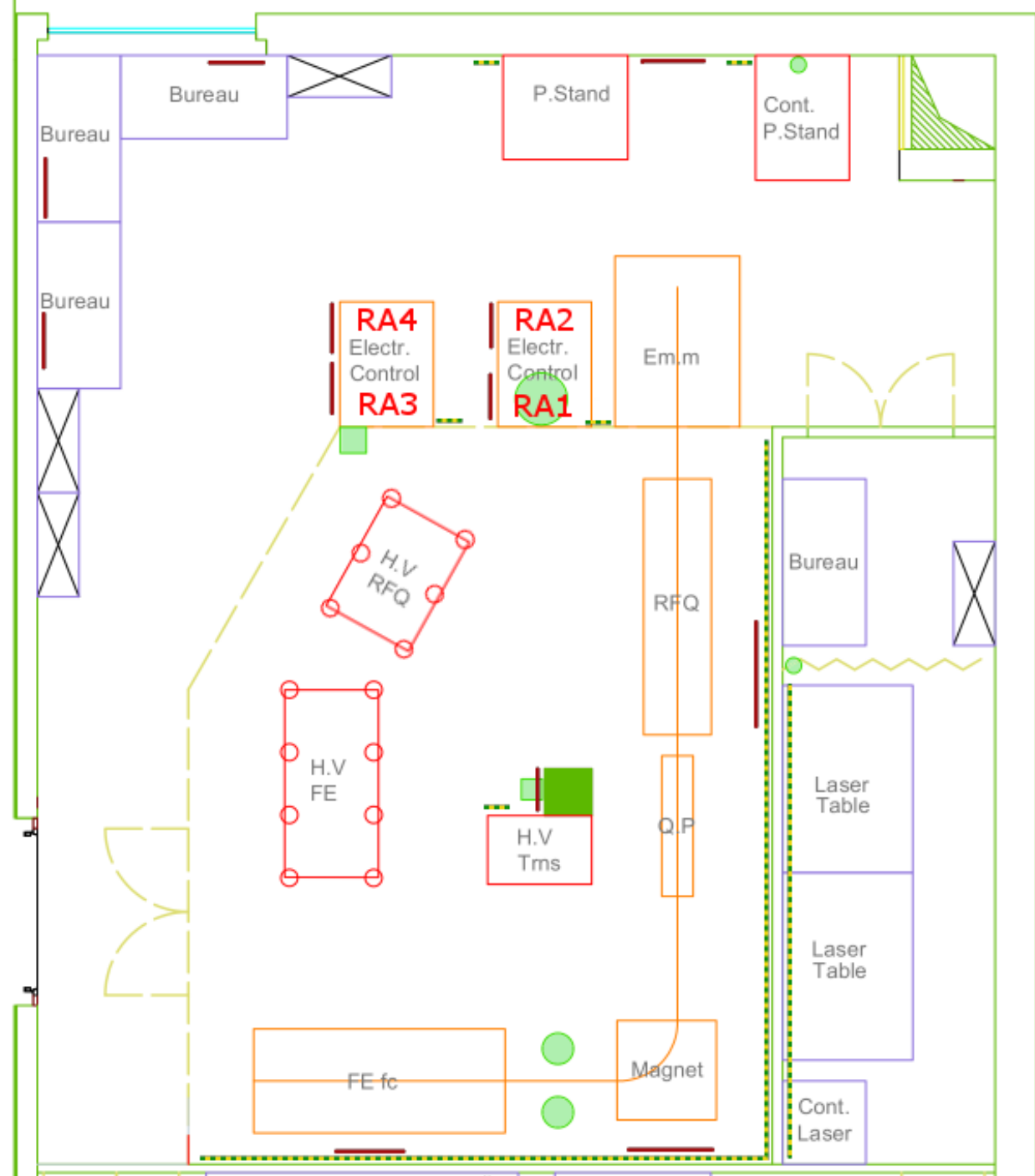

What beam line components we had

- Front End 8, a copy of the front end used for ISOLDE
- Danfysik 90° dipole Magnet
- Part constructed RFQcb
 - Missing injection & extraction electrode assembly
 - Missing stands and pumping stations
 - Missing all controls and RF amplifiers
- Quadrupole triplet with stand.. But missing locking bolts
- 2 beam scanner boxes

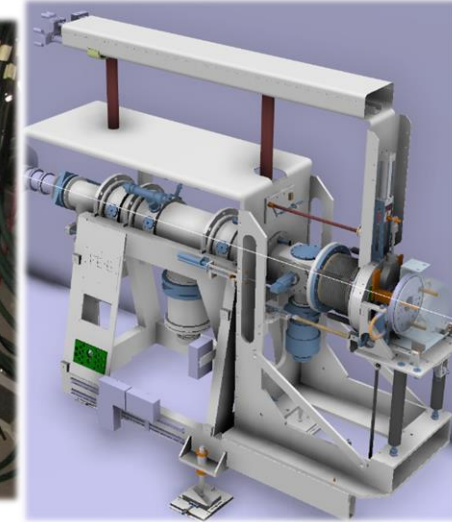
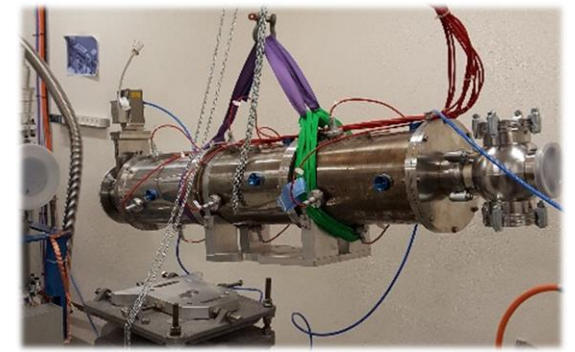

Beam layout – COSY Infinity

$$\begin{pmatrix} x \\ a = p_x/p_0 \\ y \\ b = p_y/p_0 \\ l = v_0 \cdot (t - t_0) \\ d = (K - K_0)/K_0 \\ g = (m - m_0)/m_0 \end{pmatrix} M = \begin{pmatrix} \langle x|x \rangle & \langle x|a \rangle & \langle x|y \rangle & \langle x|b \rangle & \langle x|t \rangle \\ \langle a|x \rangle & \langle a|a \rangle & \langle a|y \rangle & \langle a|b \rangle & \langle a|t \rangle \\ \langle y|x \rangle & \langle y|a \rangle & \langle y|y \rangle & \langle y|b \rangle & \langle y|t \rangle \\ \langle b|x \rangle & \langle b|a \rangle & \langle b|y \rangle & \langle b|b \rangle & \langle b|t \rangle \\ \langle K|x \rangle & \langle K|a \rangle & \langle K|y \rangle & \langle K|b \rangle & \langle K|t \rangle \\ \langle m|x \rangle & \langle m|a \rangle & \langle m|y \rangle & \langle m|b \rangle & \langle m|t \rangle \\ \langle q|x \rangle & \langle q|a \rangle & \langle q|y \rangle & \langle q|b \rangle & \langle q|t \rangle \end{pmatrix}$$

- Beam line was modelled with COSY infinity
- Optimised for the RFQcb acceptance:
 - Aperture r=4 mm
 - a < 15 mRad
 - Symmetrical beam a/b=1
- Gave the values for
 - Drift lengths
 - Maximum potentials for QP's
- Gave the transfer matrix M for the beamline

$$R = \frac{(X|\delta m)}{2x_{00}(X|X) + \Delta} = \frac{(X|\delta m)}{2x_{final}} = 495.73$$

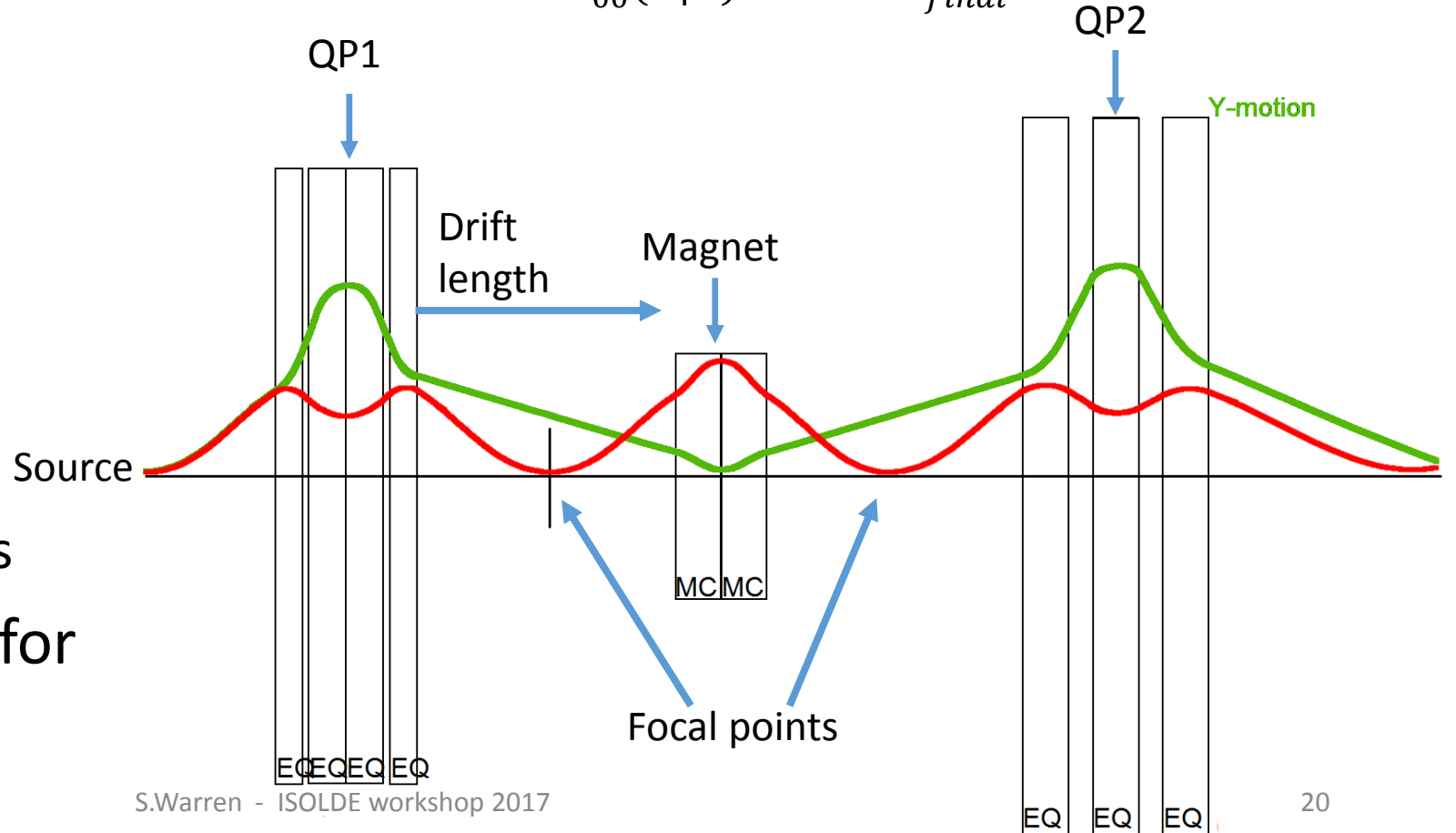

COSY infinity Transport results

ion beam post transport X vs a

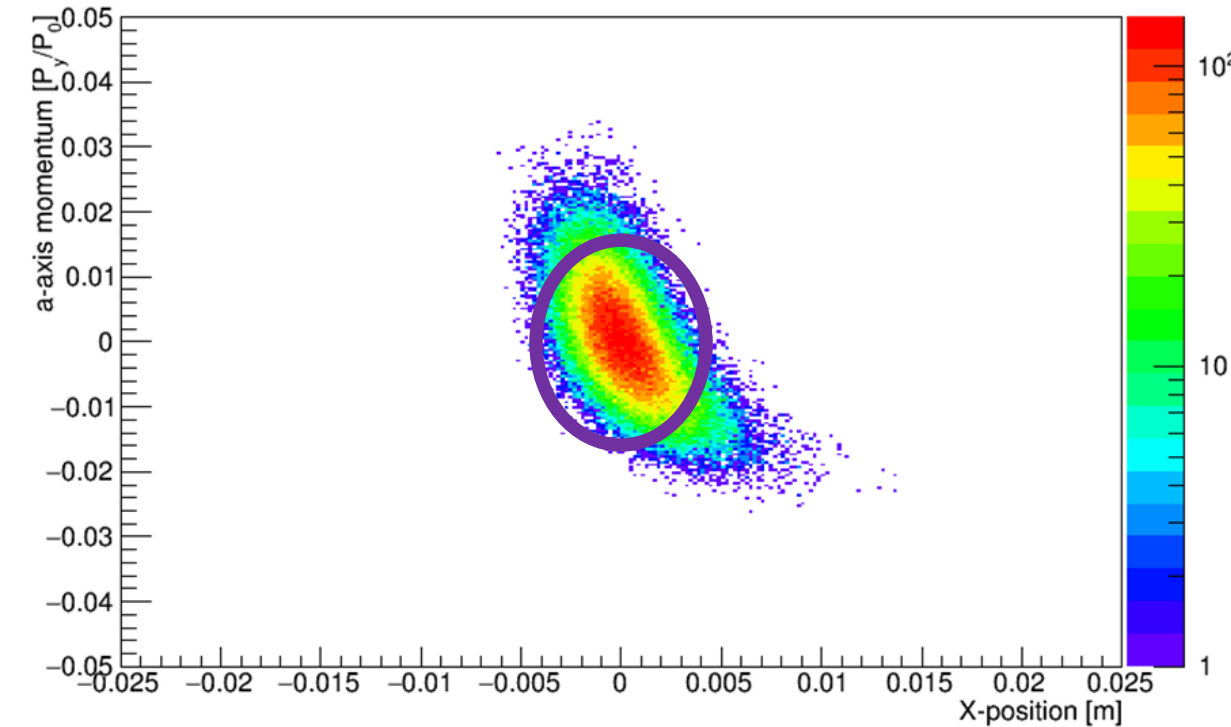

ion beam post transport Y vs b

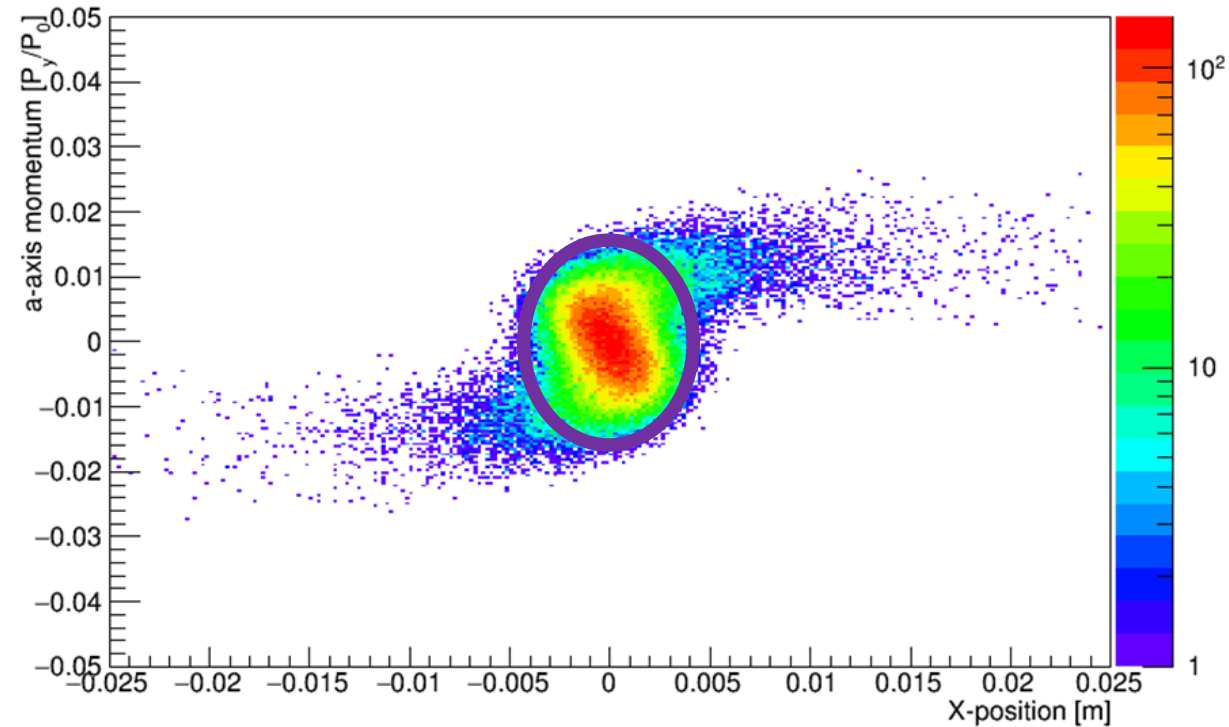

Calculated acceptance of 94% for beam with Gaussian distribution of (X,a) and (Y,b)

NOTE: emittance ε is un changed,

So is it ready?

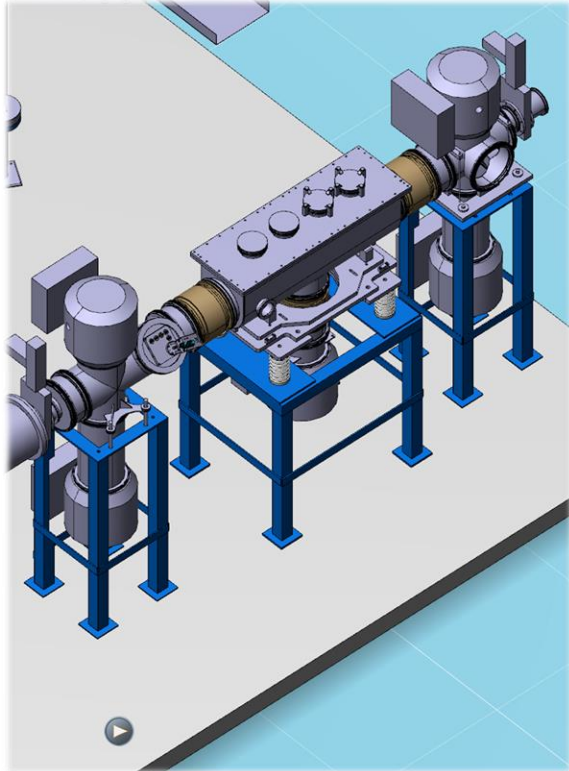

- ✓ Beam drift pipes
- ✓ Equipment aligned
- ✓ Power converters
- ✓ Beam monitoring
- ✓ Holes in floor fixed!
- ✓ Cooling installed
- ✓ Interlocks
- ✓ Controls
- ✓ Vacuum
- ✓ HV

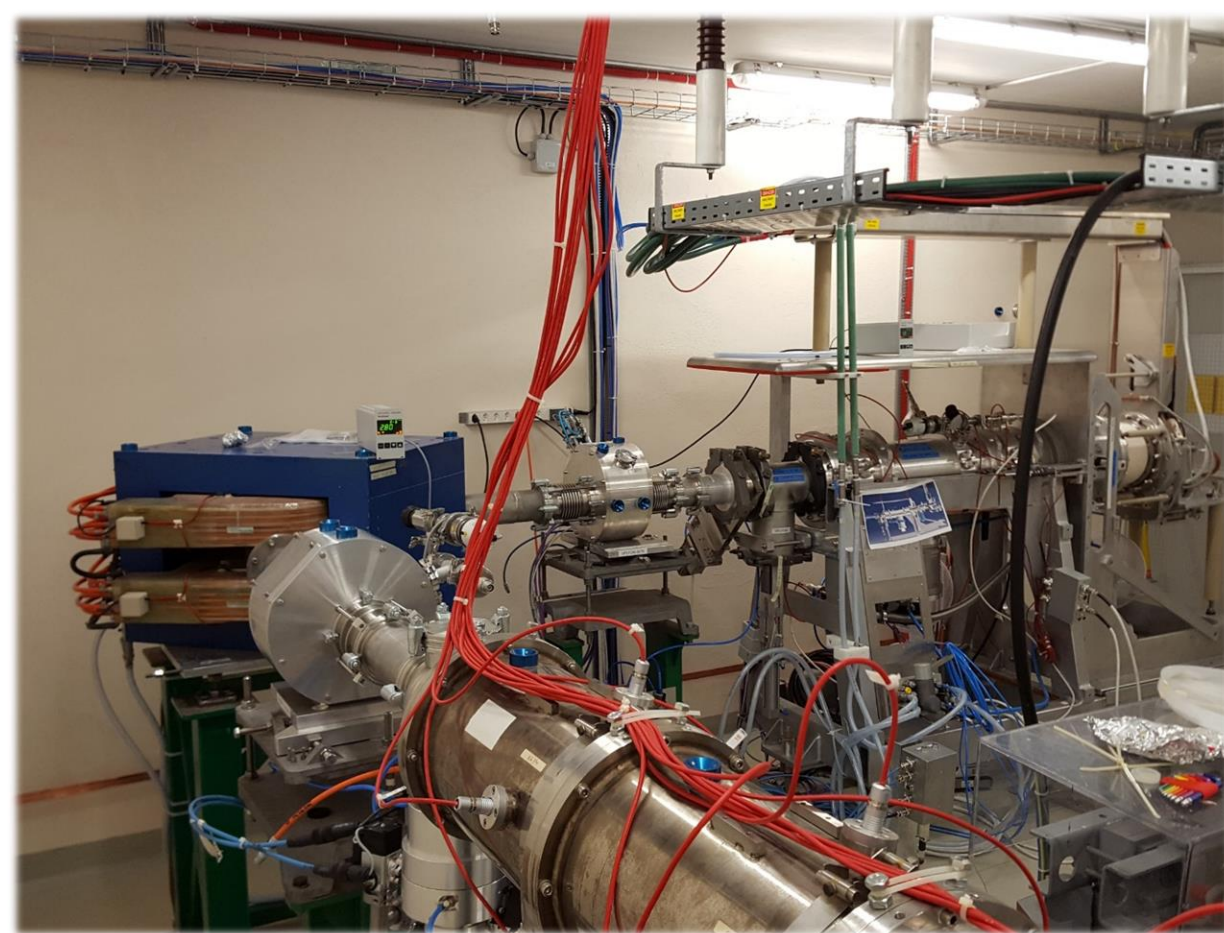

**Pushing for beam through magnet
before end of year!**

RFQ will be next summer

Testing planned

- **RFQcb amp** – RF waveform effects on beam
- **Controls and switches for RFQcb** - modified extraction techniques for RFQ improve longitude emittance!!!
- **Gas controls** – prototype an automated gas controls system to optimize beam transport quality online
- **RFQcb pressure investigation** – Prove simulations validity and emittance
- **Molecular break up in RFQcb** – CO breakup investigation (Annie)
- **Bunching emittance** – new beam Time of flight detector system
- And much more!!

Thank you for your attention

And thanks to the team:

- Annie Ringvall Moberg
- Carlos Munoz Pequeno
- Tim Giles
- James Matthew Cruikshank
- The EN-STI-RBS group

Bon Appétit!

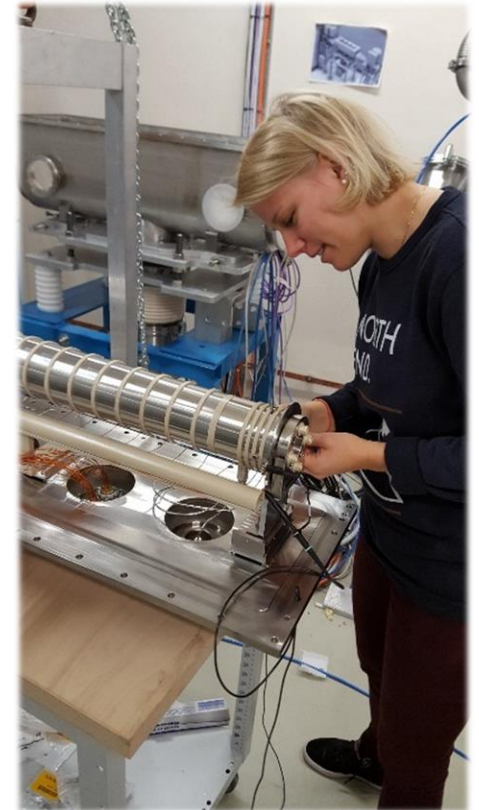

Backup stuff

Cu

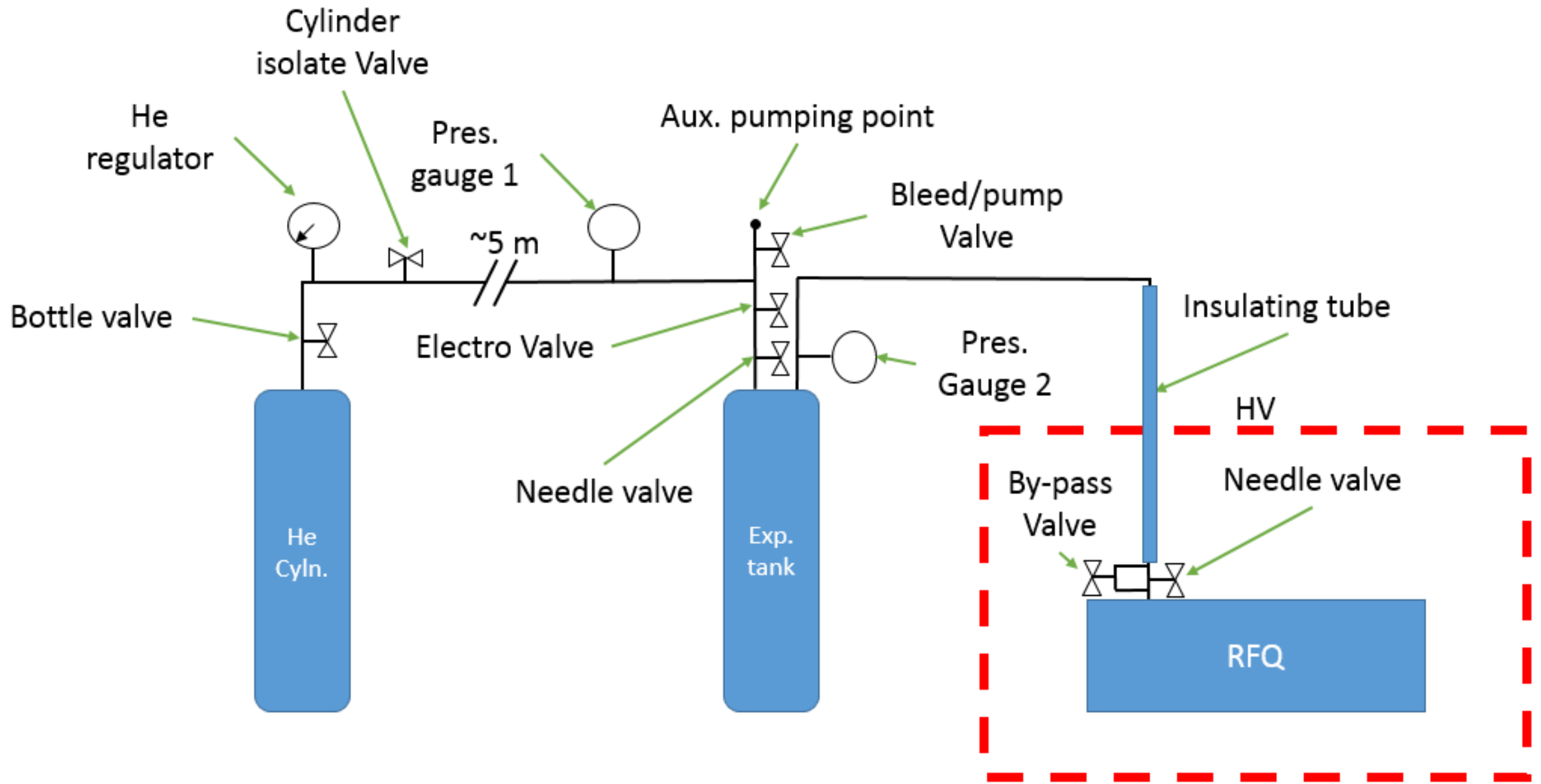

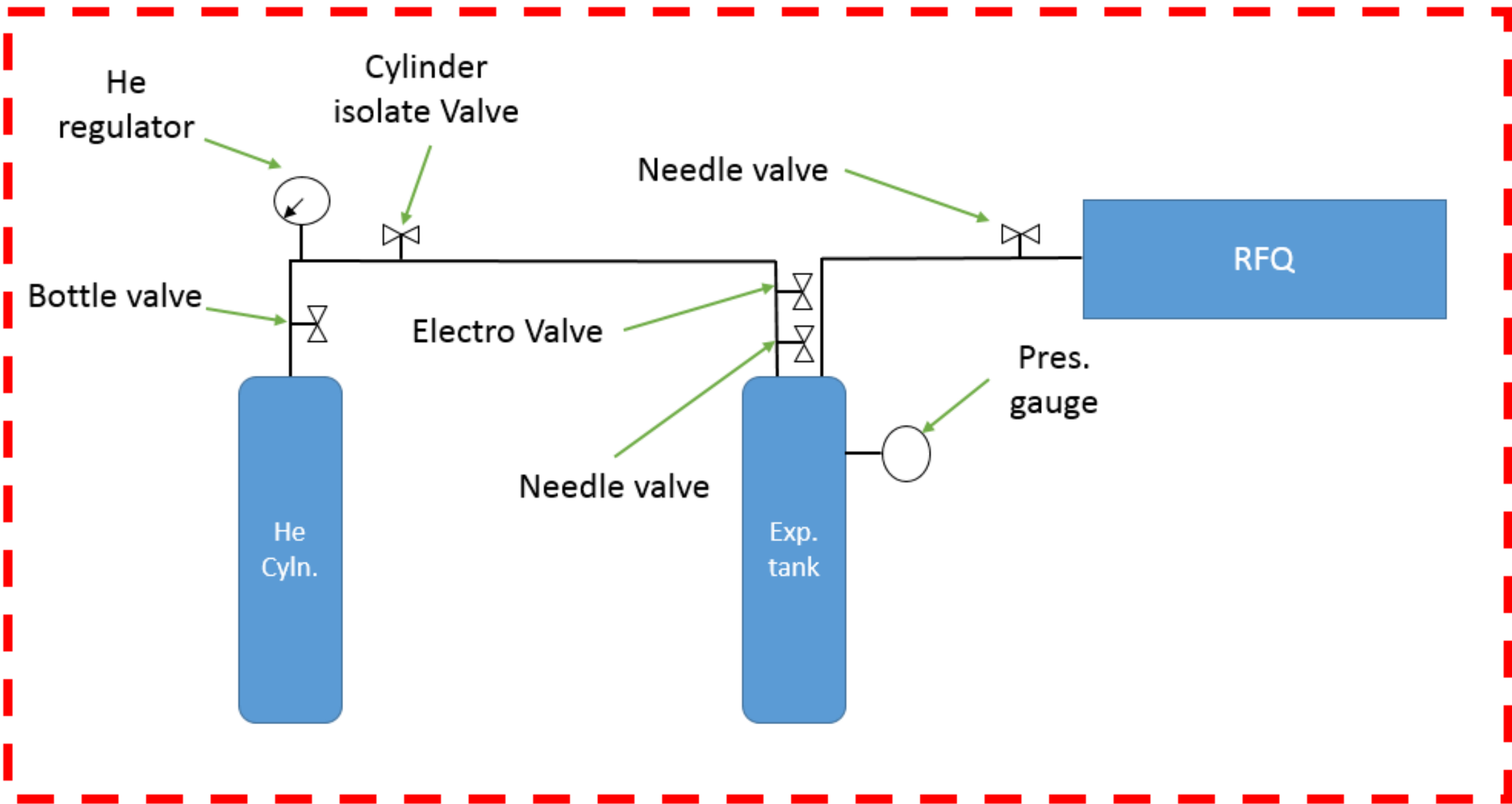

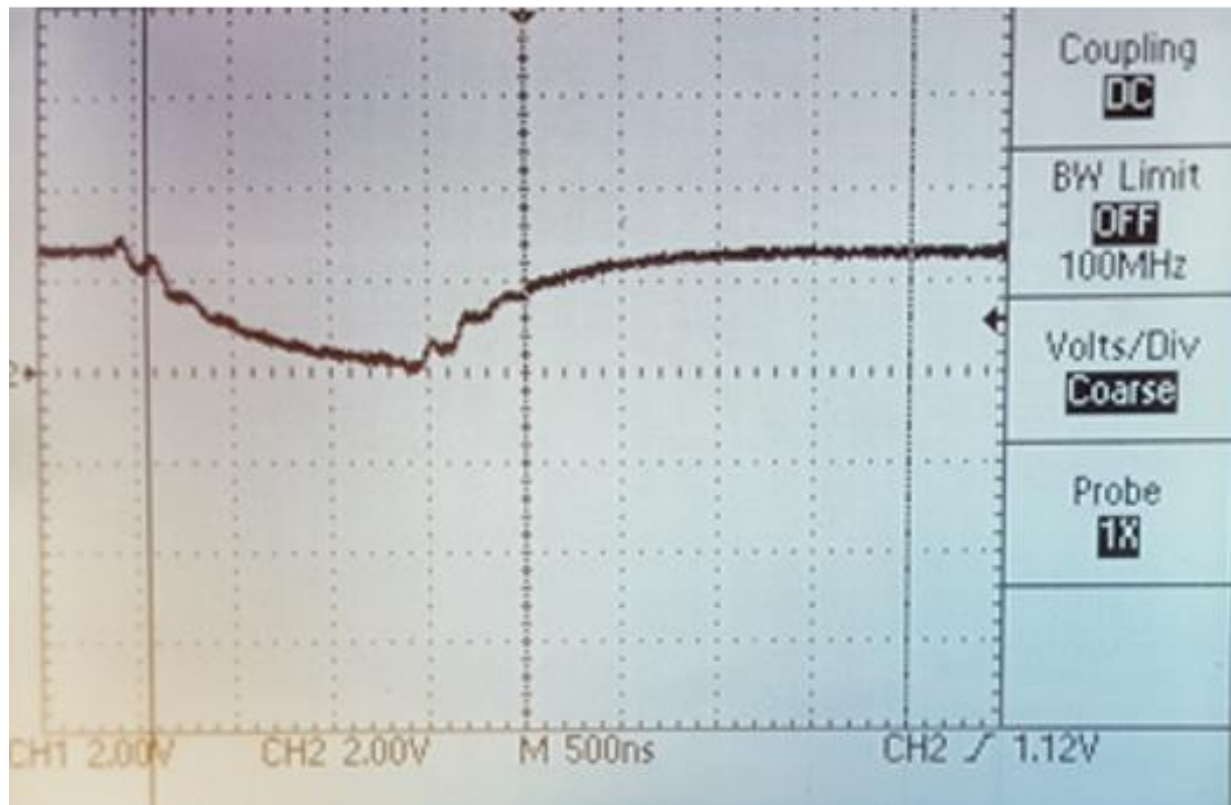

All in Meters

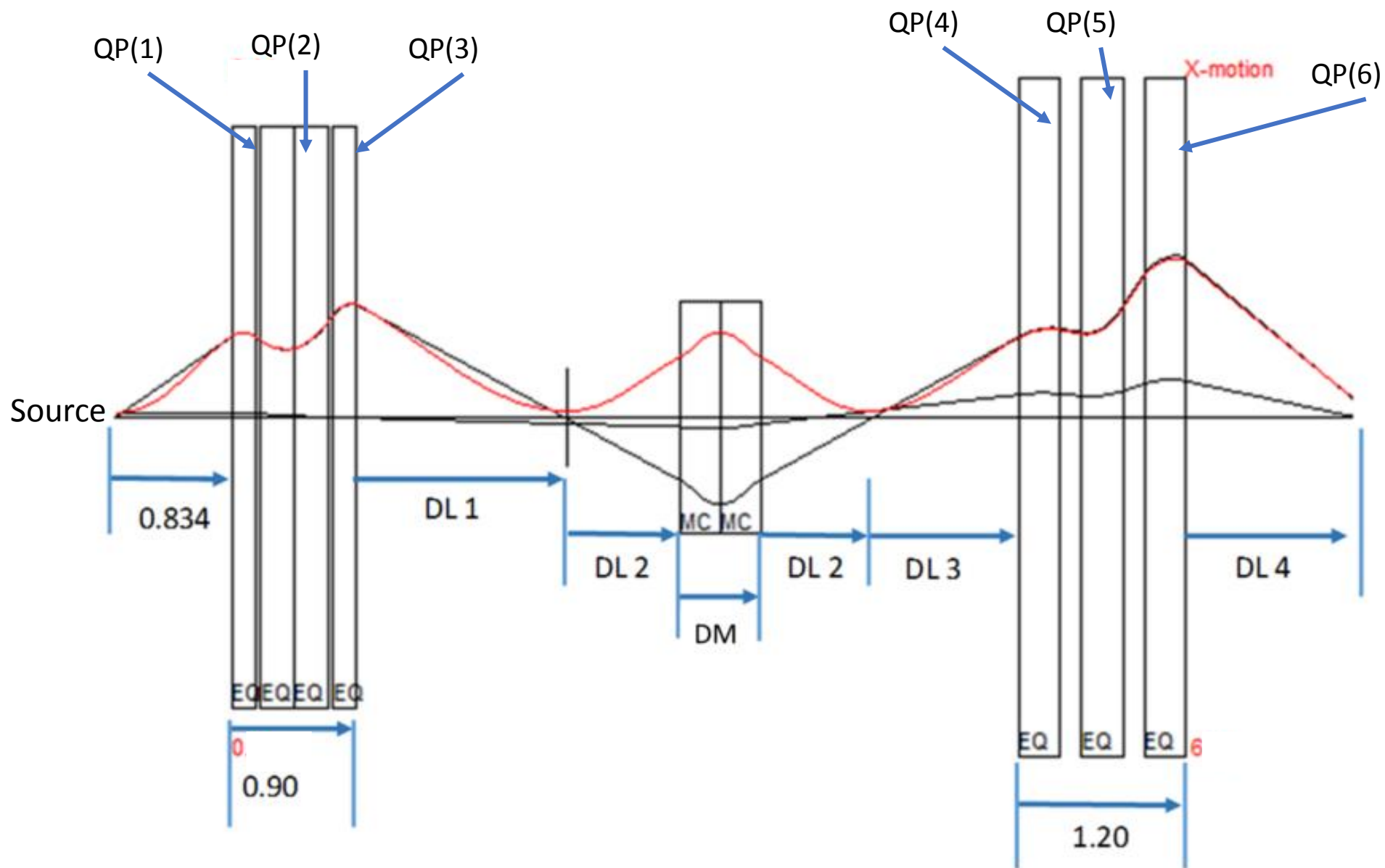

$P=1e-7$ mb, $RF=340$ kHz, $160V$ (1.6), k39

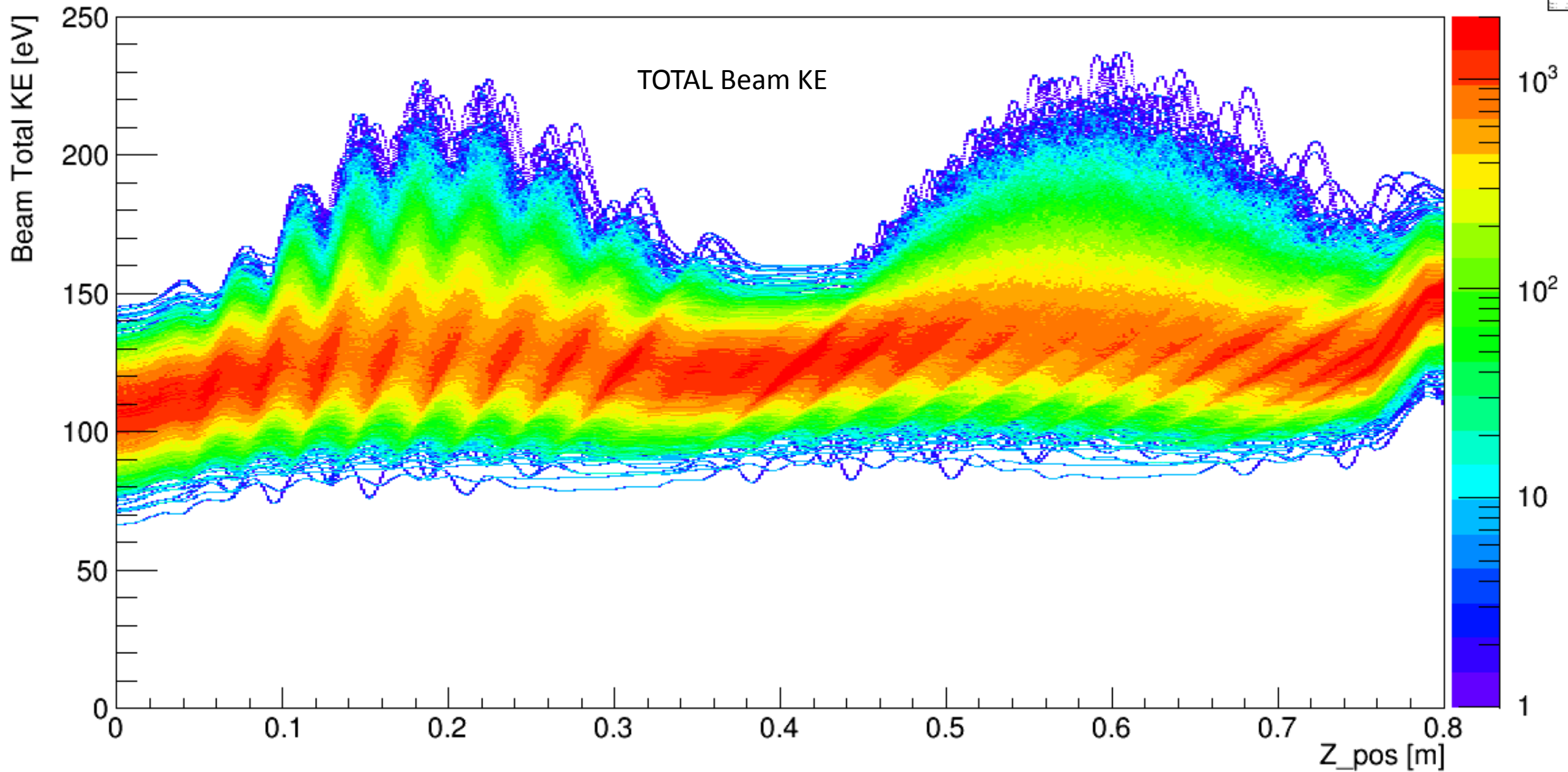

P=1 mb, RF=340 kHz, 160V (1.6), k39

