

Cryogenics in KAGRA

Joint GW & CERN Meeting

Takayuki TOMARU

High Energy Accelerator Research
Organization (KEK)

Cryogenic Mirror System

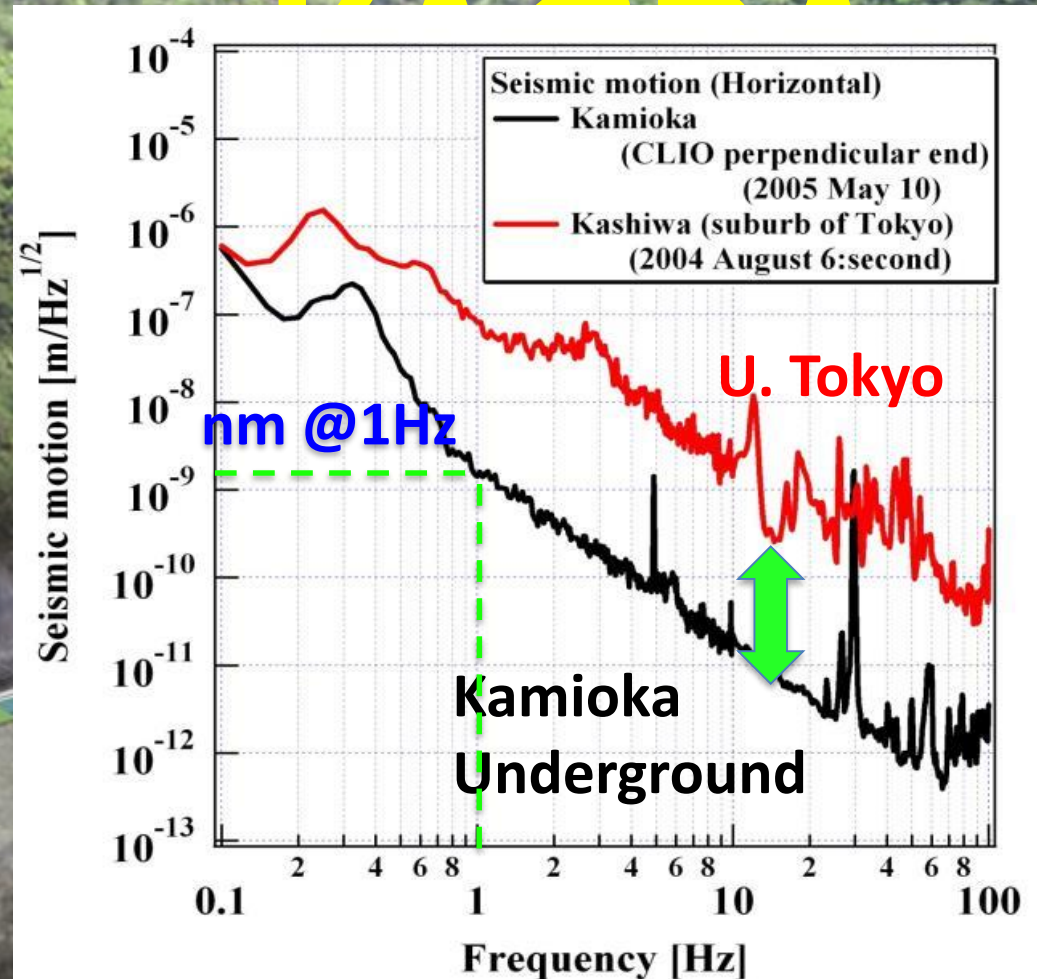
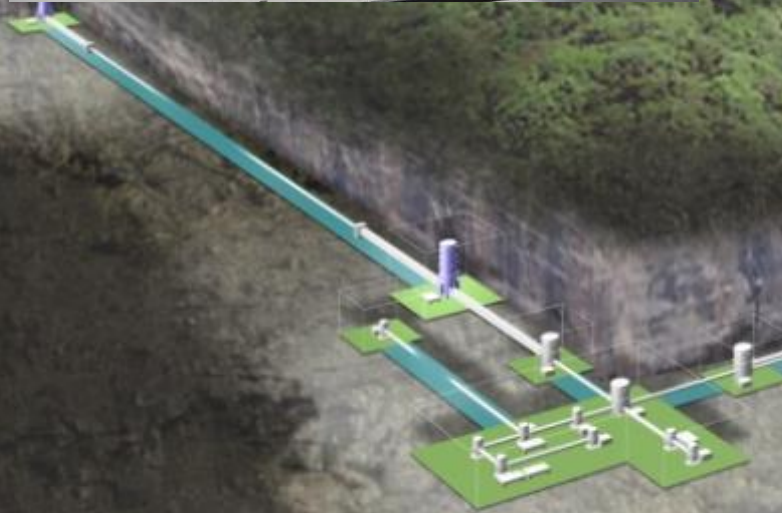

Advantage of Cryogenic Mirror System

(1) Thermal noise Reduction

$$\sqrt{x(\omega)^2} \propto \sqrt{T \phi}$$

Moreover

Sapphire

@ 20K

$$\phi = 5 \times 10^{-9} \quad (\text{bulk})$$
$$\phi = 1 \times 10^{-7} \quad (\text{fiber})$$

Typical Φ of sapphire at room temperature is $\sim 10^{-6}$



Sapphire substrate

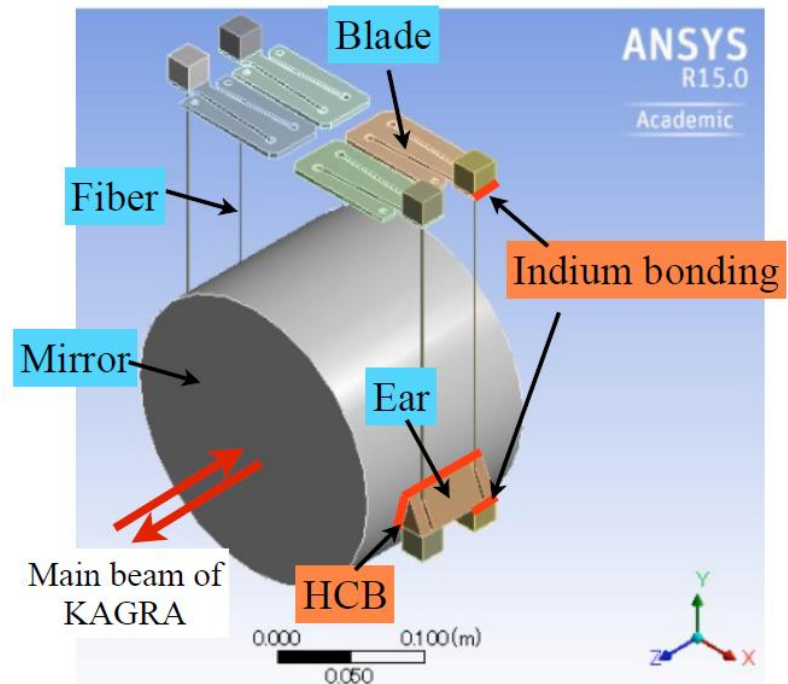

Advantage of Cryogenic Mirror System

(2) Thermal Lensing

	Fused Silica (300K)	Fused Silica (20K)	Sapphire (300K)	Sapphire (20K)
α [ppm/cm]	2 - 20	2 - 20?	40 - 140	20 - 90?
κ [W/m•K]	1.4	0.15	46	4.3×10^3
dn/dT [K ⁻¹]	1.4×10^{-5}	1.4×10^{-5}	1.3×10^{-5}	$< 9 \times 10^{-8} $
$\alpha (dn/dT)/\kappa \times 10^{-11}$	2 - 20	20 - 200	1.1	$< 0.4 - 2 \times 10^{-4} $

Wave-front distortion at input mirror at 300K

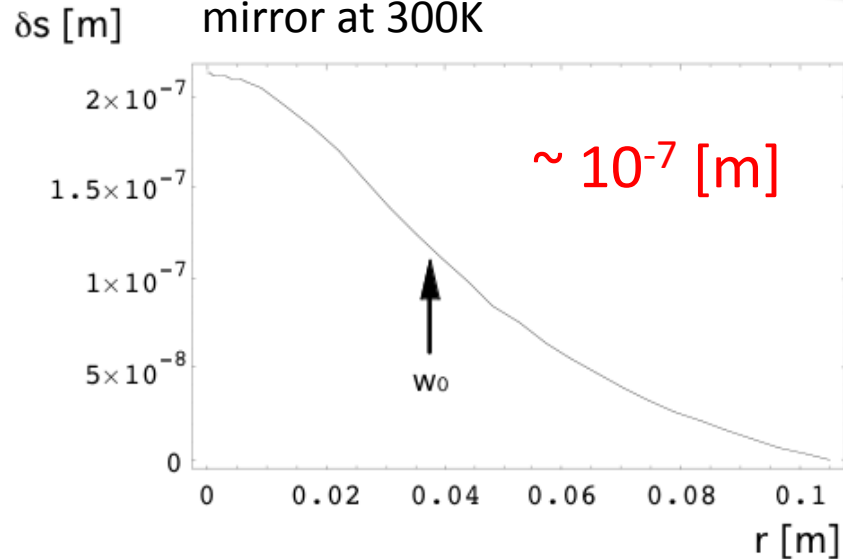

Wave-front distortion at input mirror at 20K

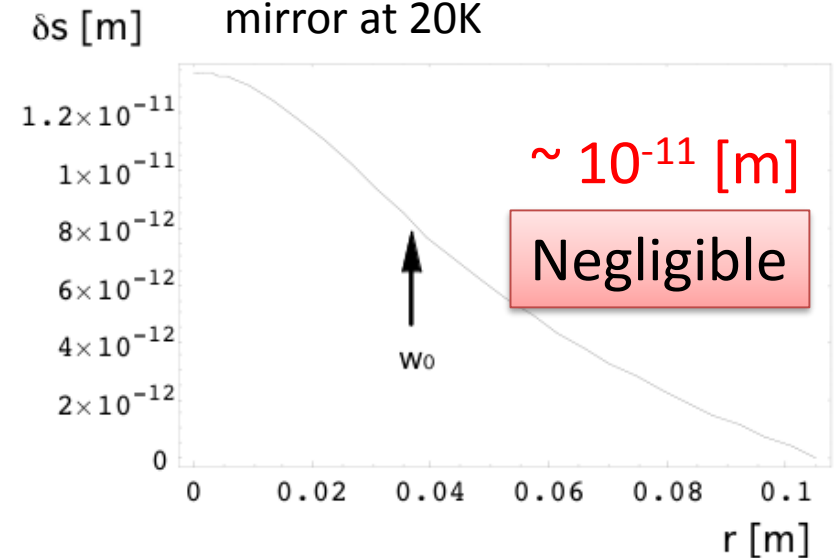

Outline of Cryogenic Systems



Frame-Free Suspension

We excavate upper-floors and vertical holes for Vibration Isolation System. Base of the VIS is put on the upper-floor

Upper Floor

14m

Type-A suspension:
4-stage GAS filters
@ room temperature

Bottom Floor

Arm tunnel

Cryogenic Payload

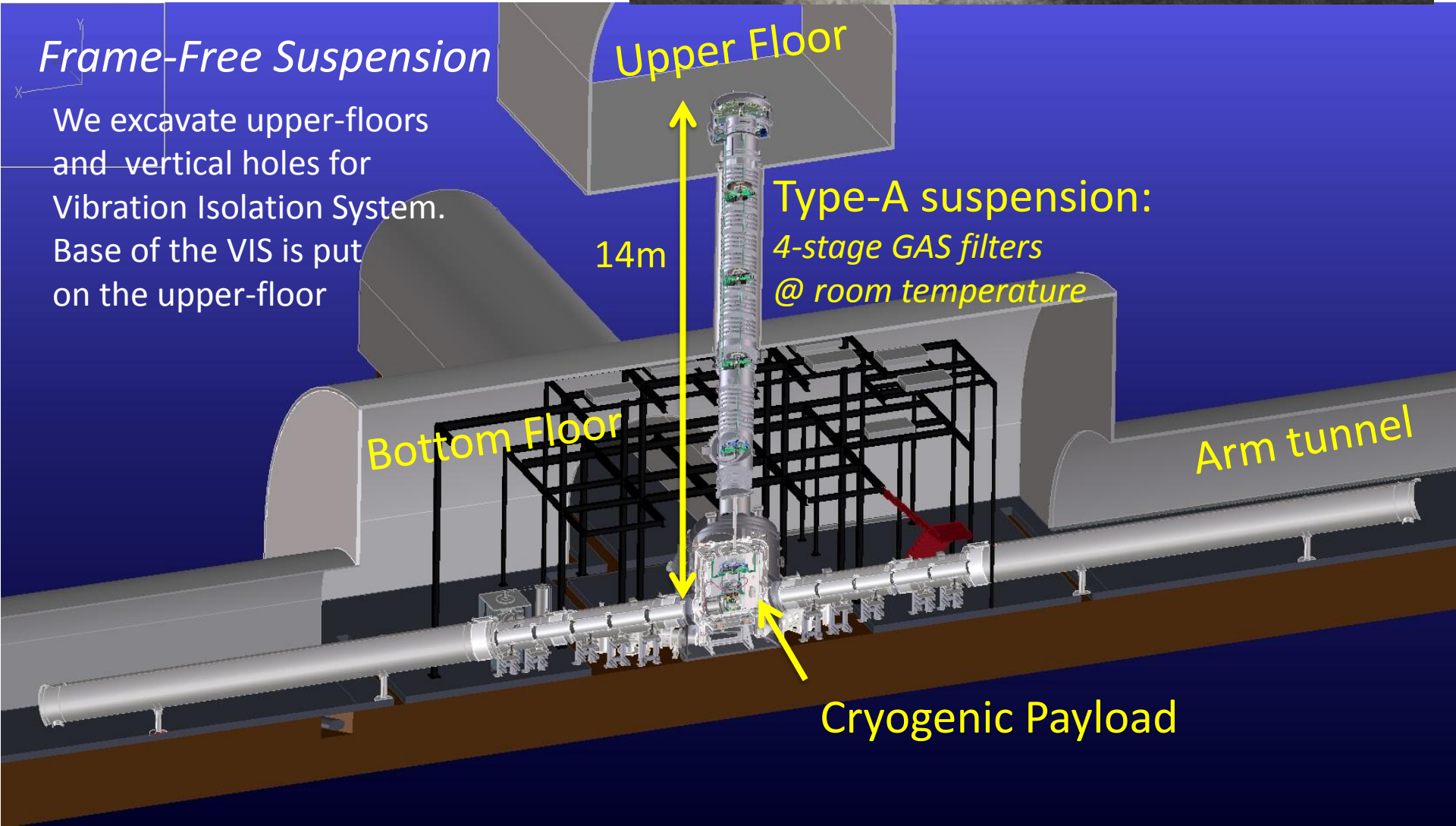

Outline of Cryogenic Systems

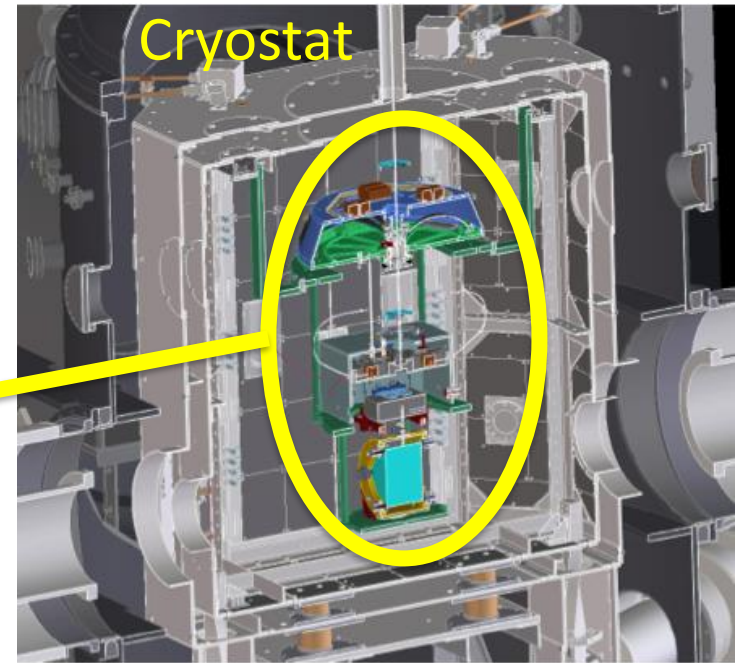

Type-A ↑

Platform

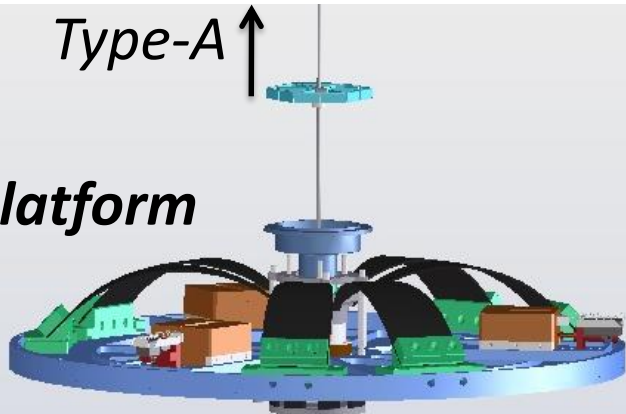

Marionette & Recoil mass



Intermediate mass & recoil mass



Mirror & Recoil mass

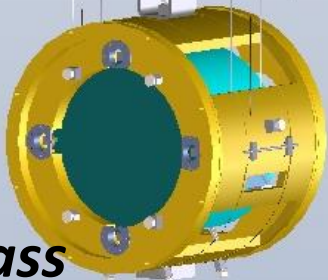

Accelerator Science Technologies

-> Vacuum, Cryogenics, ... in GW detector

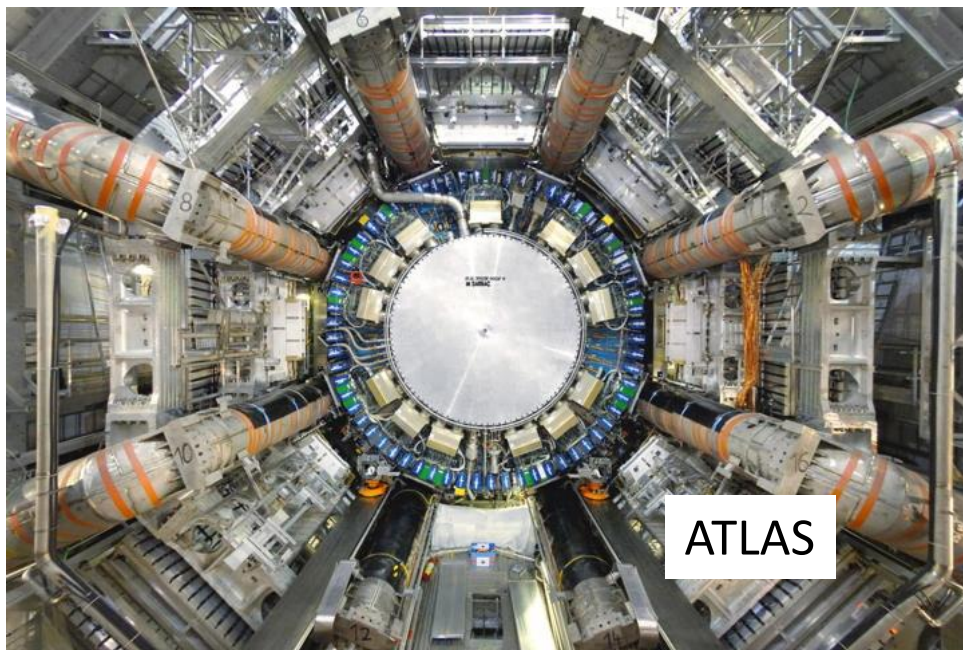

ATLAS



J-PARC Superconducting
Beam line for Neutrino

KAGRA Cryostats



Layout of Cryostats

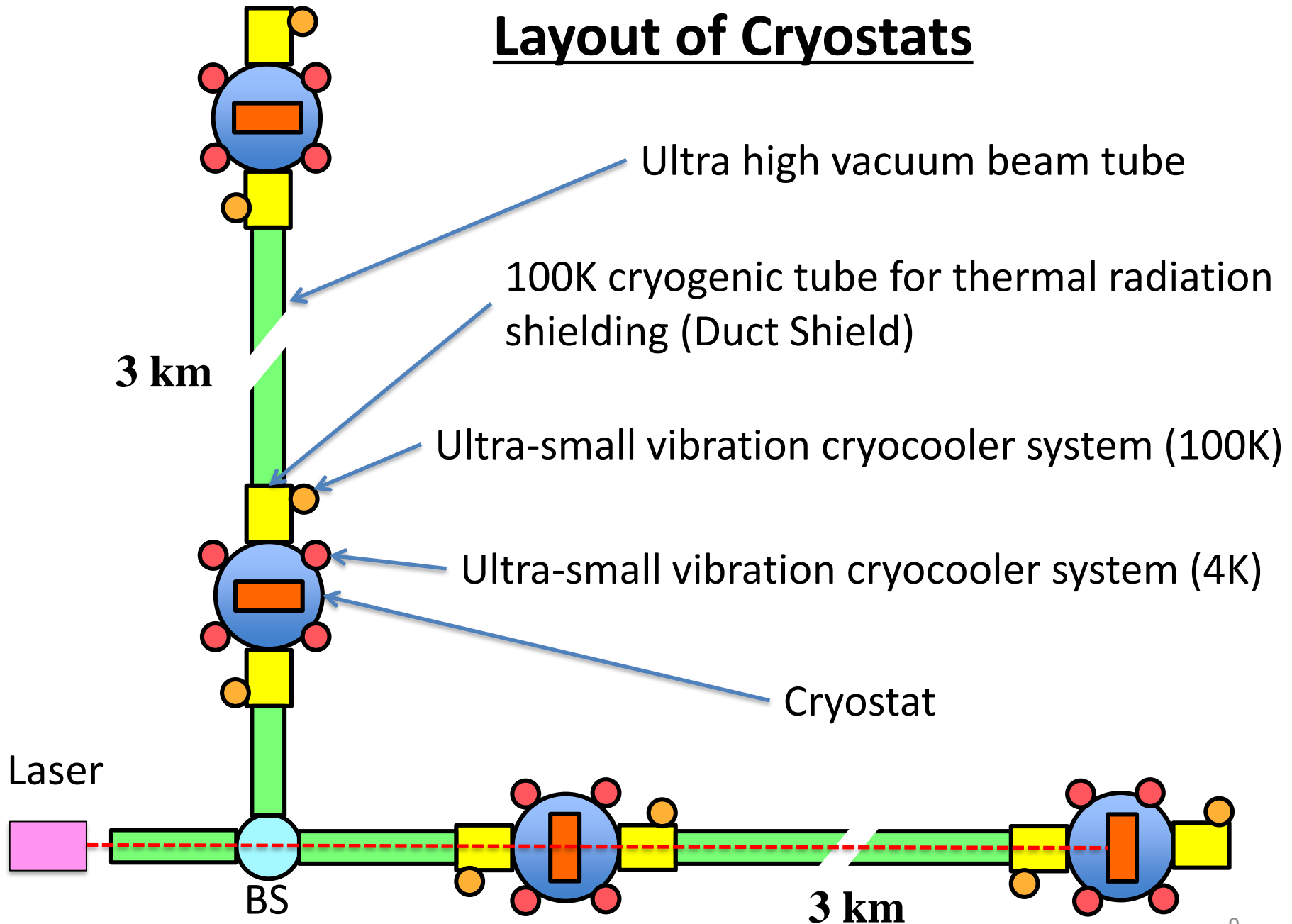

Reduction of thermal radiation

To realize conduction cooling by using small cryocoolers, heat load in cryostat must be below several watt.

But GW interferometer can not have optical windows on laser beam path, so large heat load from the openings exists.

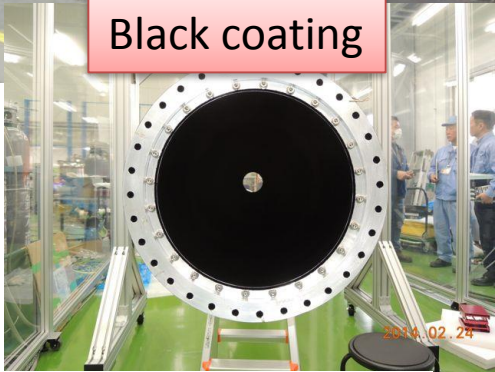
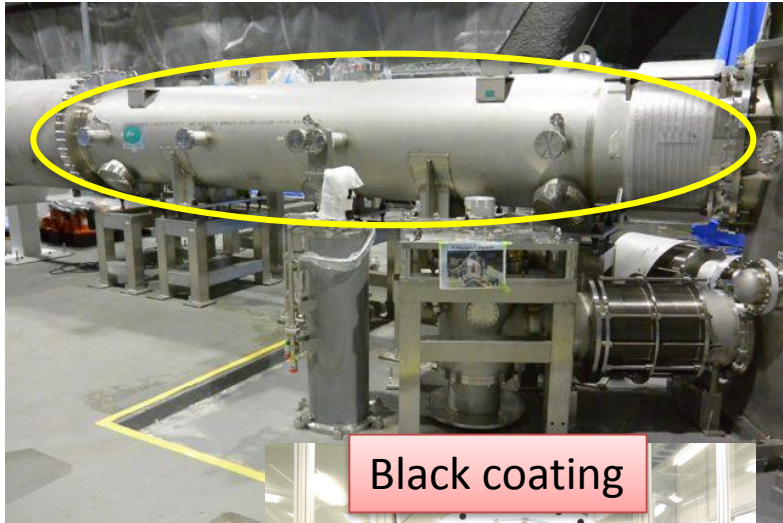

We succeeded to reduce about 1/1000 times thermal radiation heat load from beam openings by using 100K cold tubes with black coating and baffles.

Black coating and baffles in cold tube

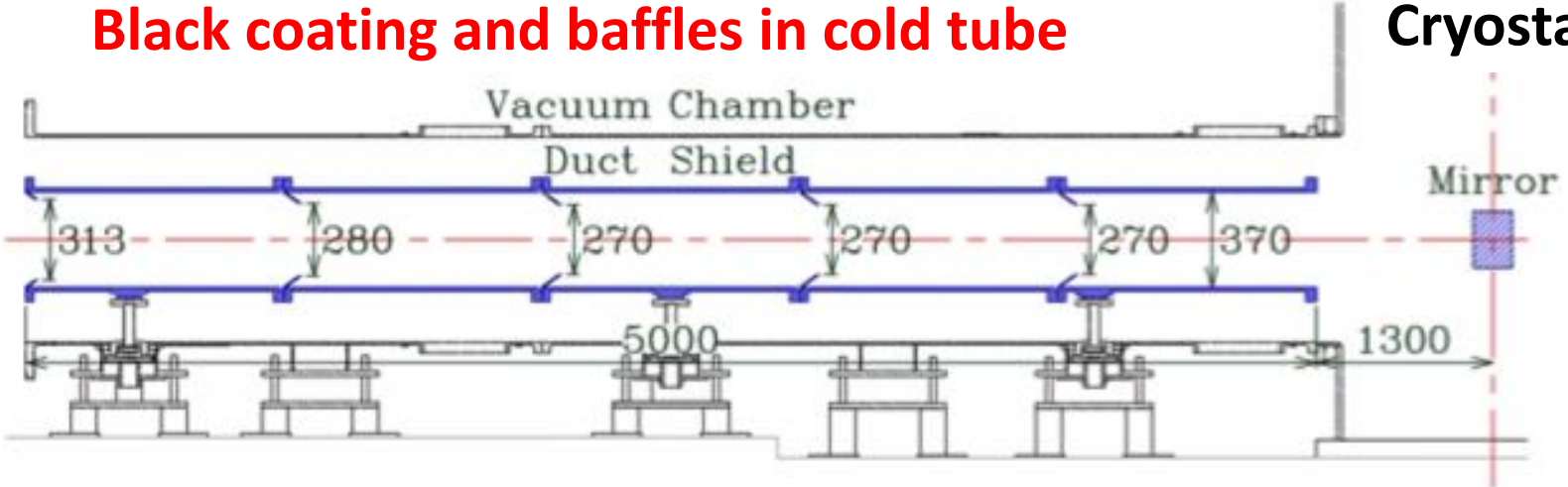

Black Coating for Ultrahigh Vacuum

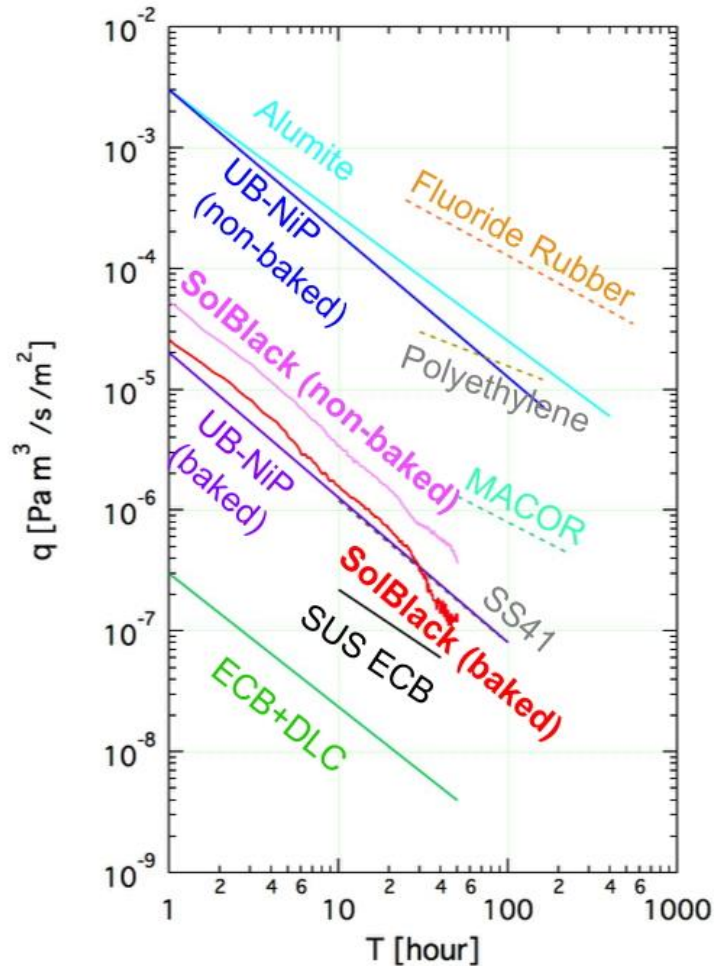

Nickel-Phosphorus black plating realize comparable level of outgas with Steel surface by backing.

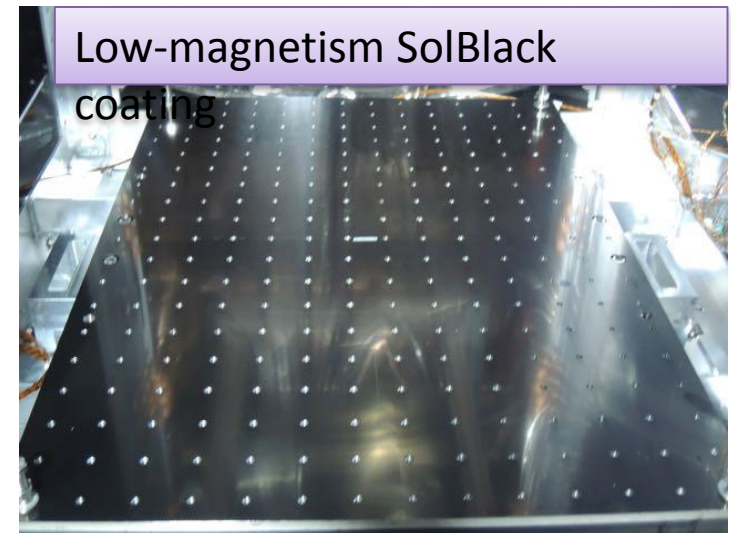

Ultra-small vibration cryocooler system

*T. Tomaru et. al.,
Cryocoolers 13, (2005) 695-702*

- **nm vibration** at cold stage
- comparable vibration level of whole system with Kamioka seismic vibration



Commercial Pulse-Tube Cryocooler

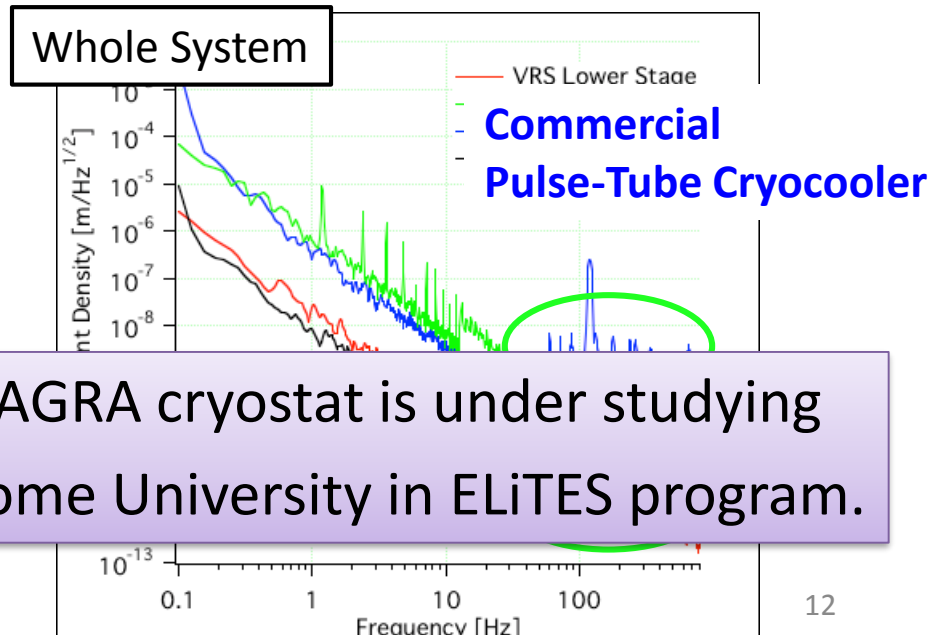
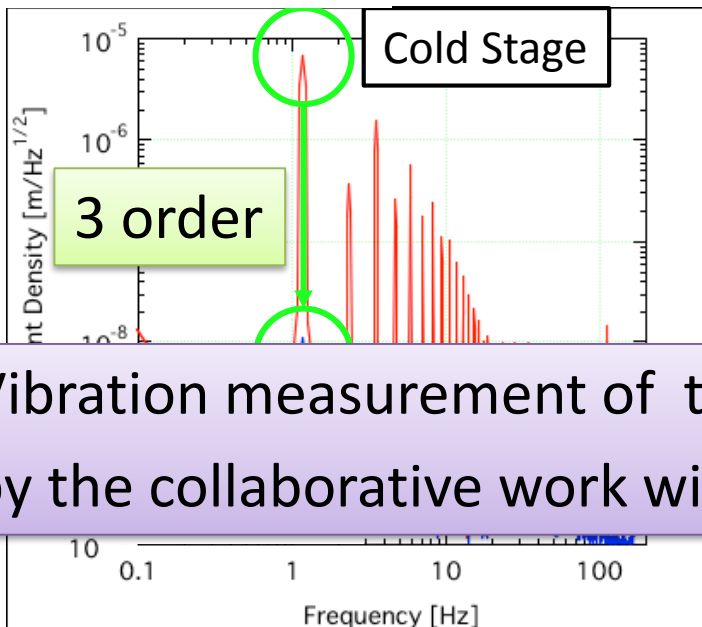

Vibration measurement of the KAGRA cryostat is under studying by the collaborative work with Rome University in ELiTES program.

Cryogenic-Payload

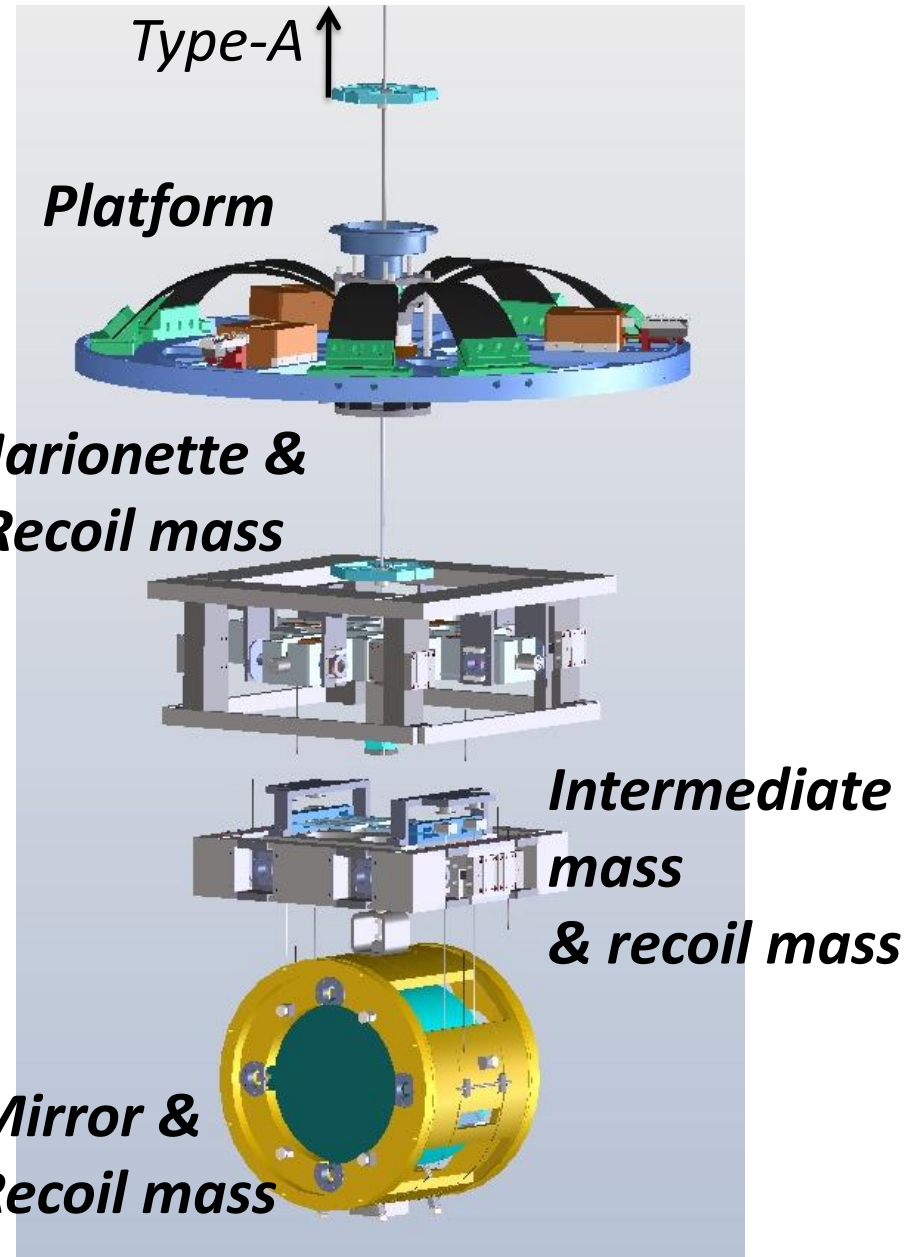
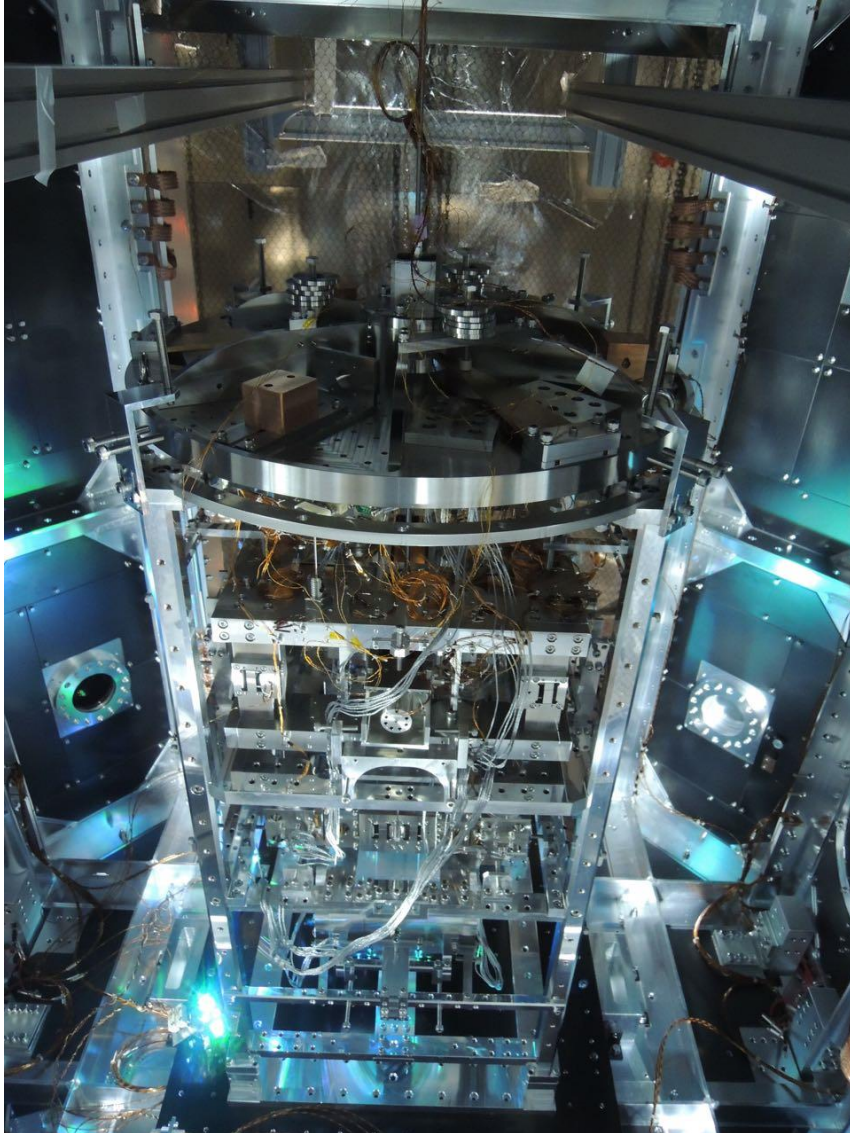

Sapphire Test Bulk Suspended by Sapphire Fibers

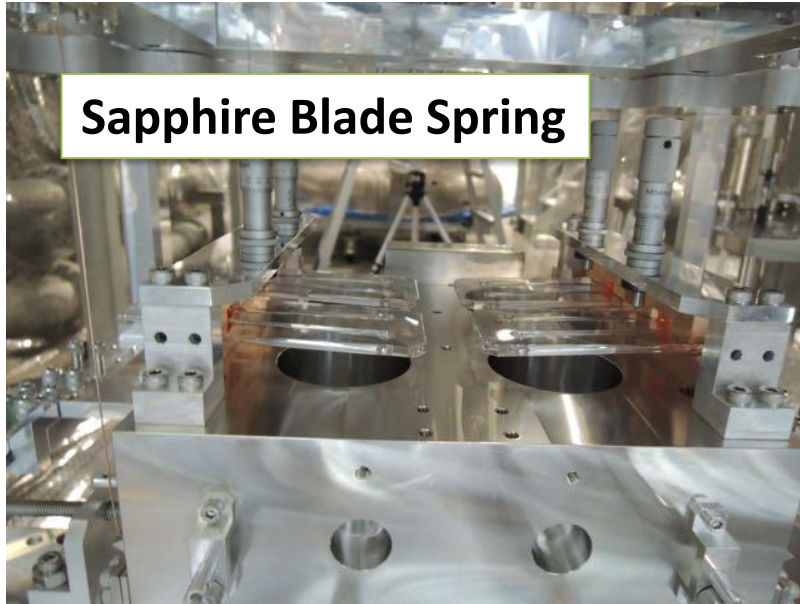

Sapphire Blade Spring

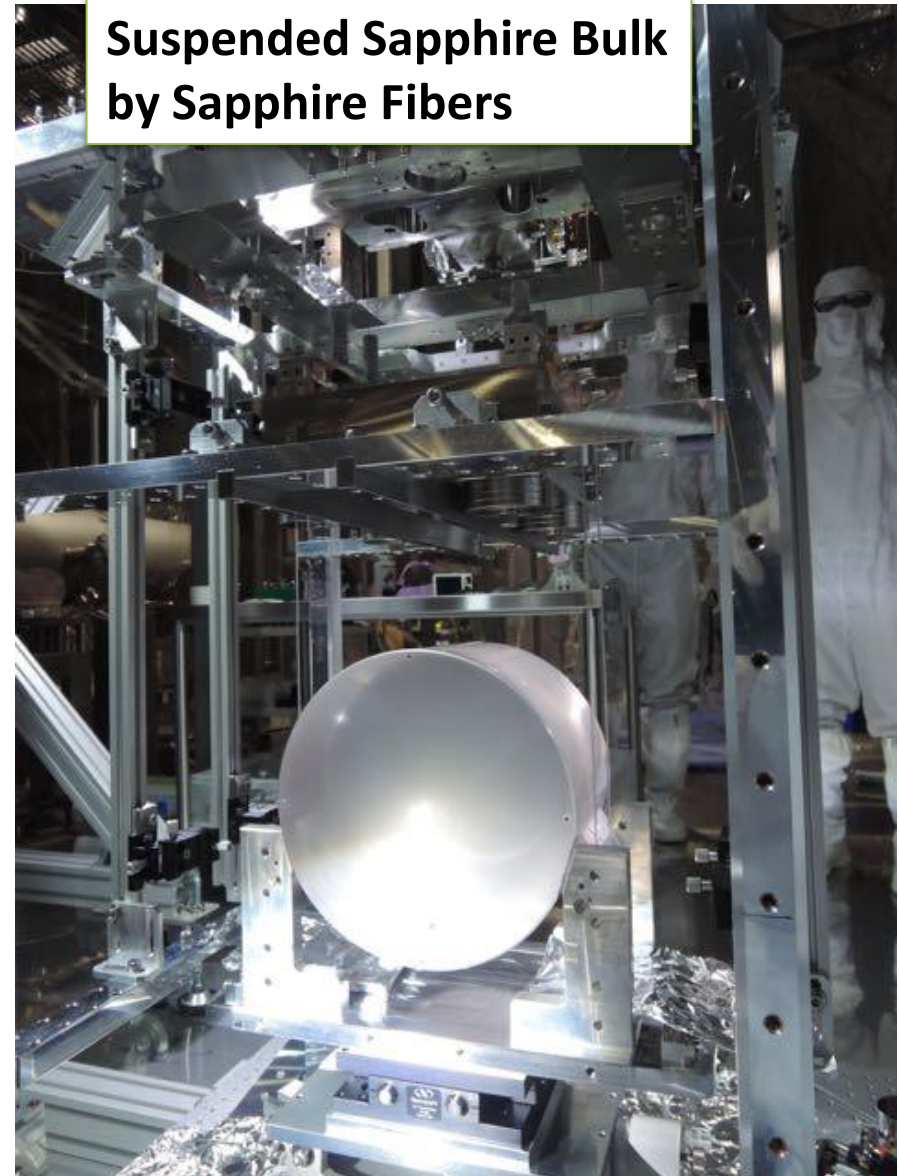

Suspended Sapphire Bulk by Sapphire Fibers



HCB Bonded Sapphire Ear & Gallium Bonding of Fibers

6N High Purity Al Heat Link

Stranded cable (made of many thin wires) has advantage to have small spring constant.

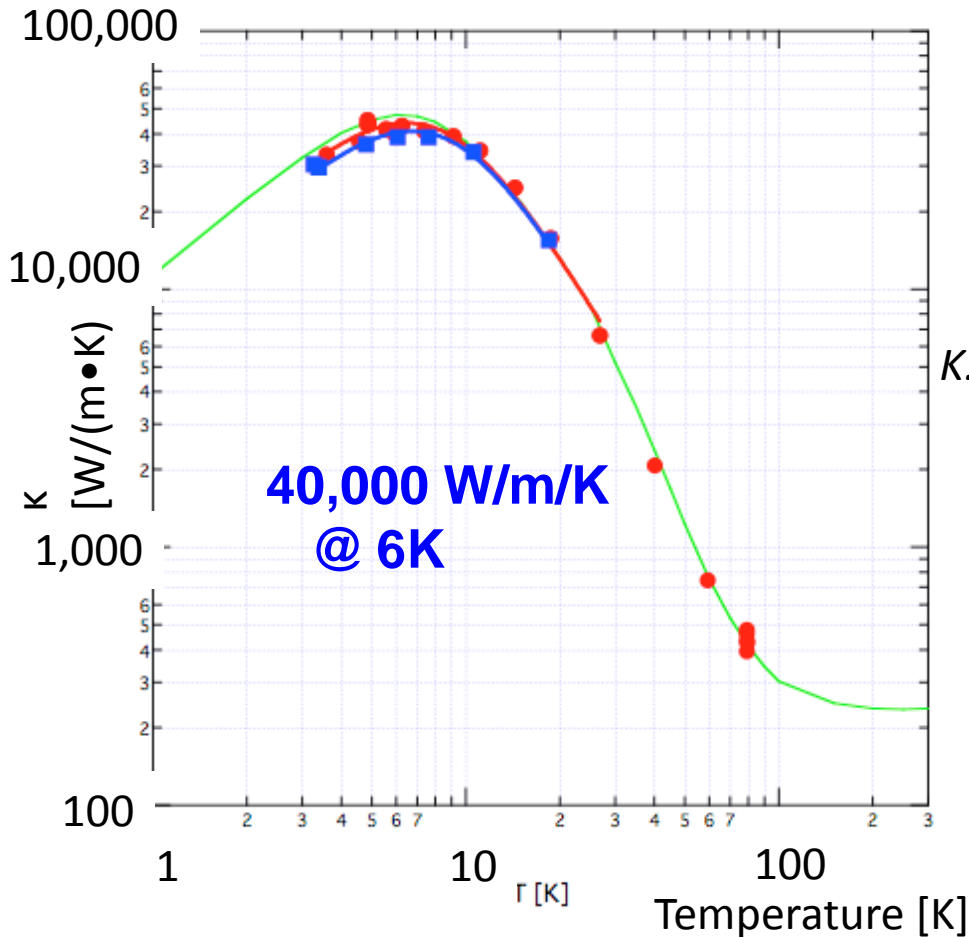

Tomaru, Teionkogaku, 46, (2011) 415.

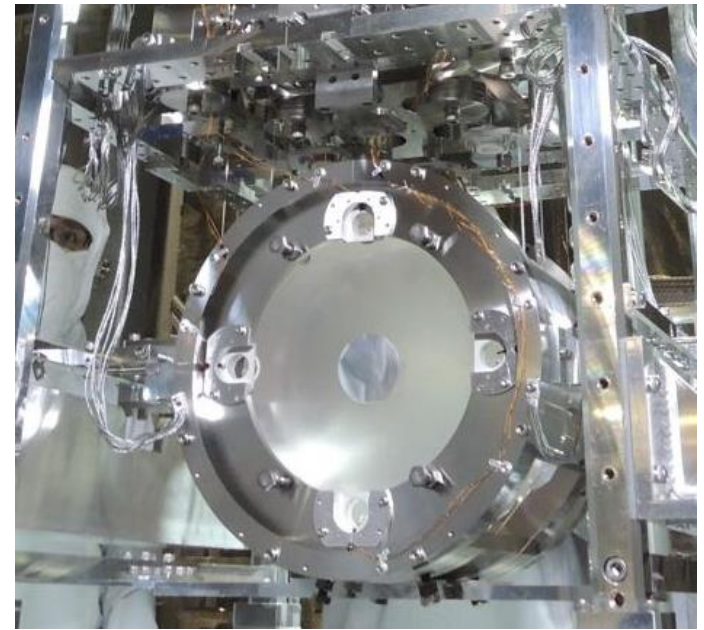

Magneto-resistance is also small

K. Hoshikawa et al., CEC 57 (2012) pp. 140-147

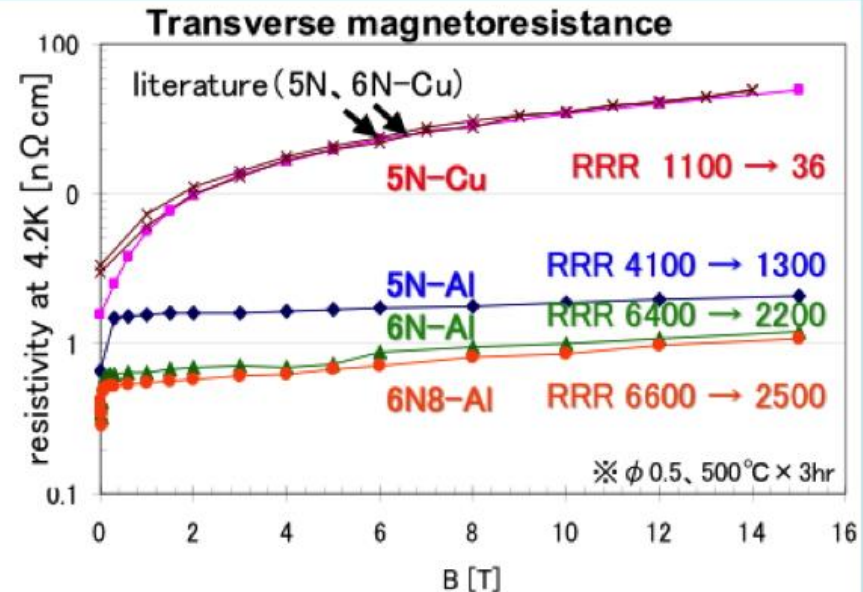

Cooling Down of EYC Test-Cryogenic-Payload

Aug, 26, 2017
KAGRA Cryogenics Team

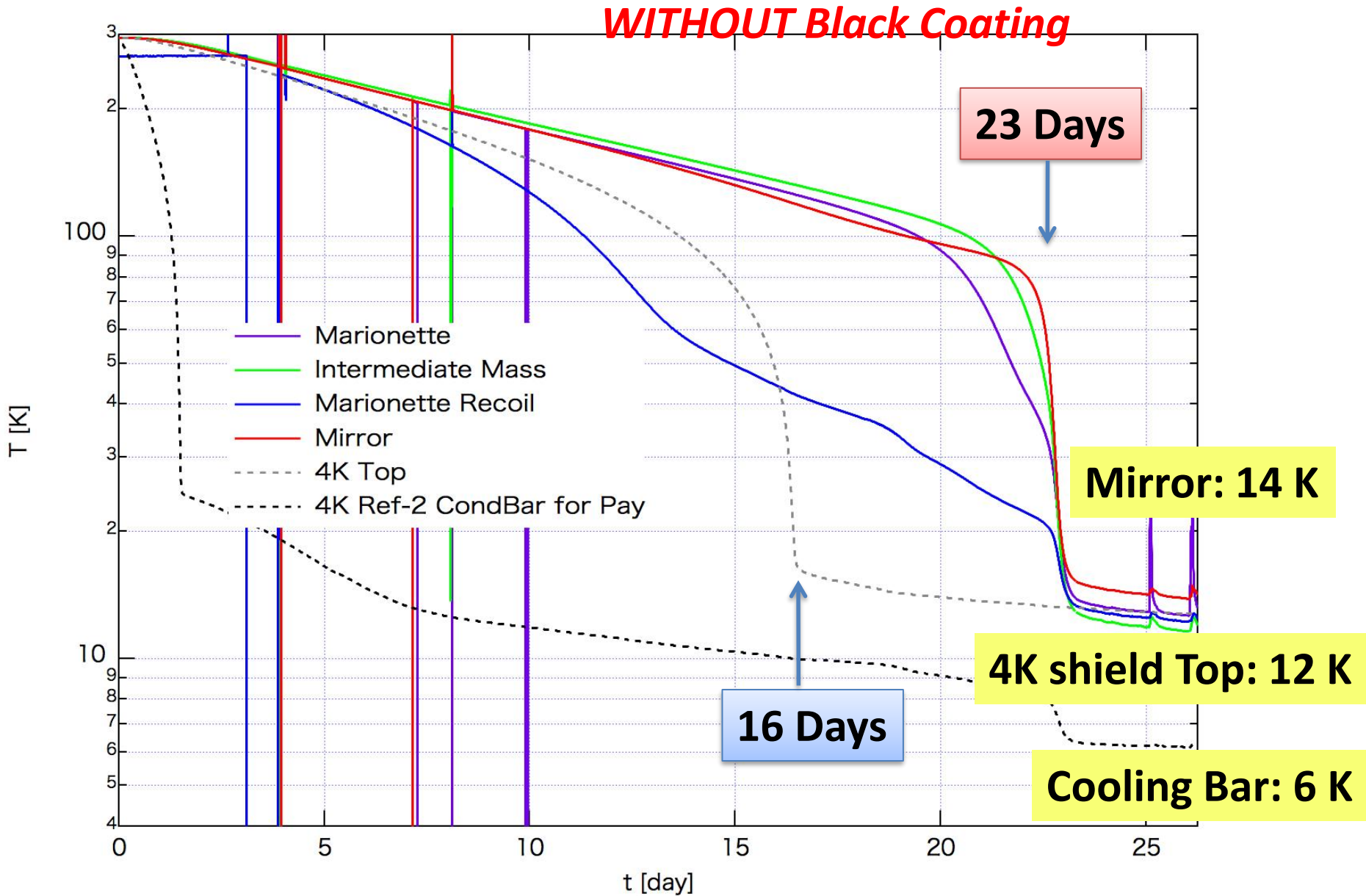

Tilting Adjustment by Moving Mass

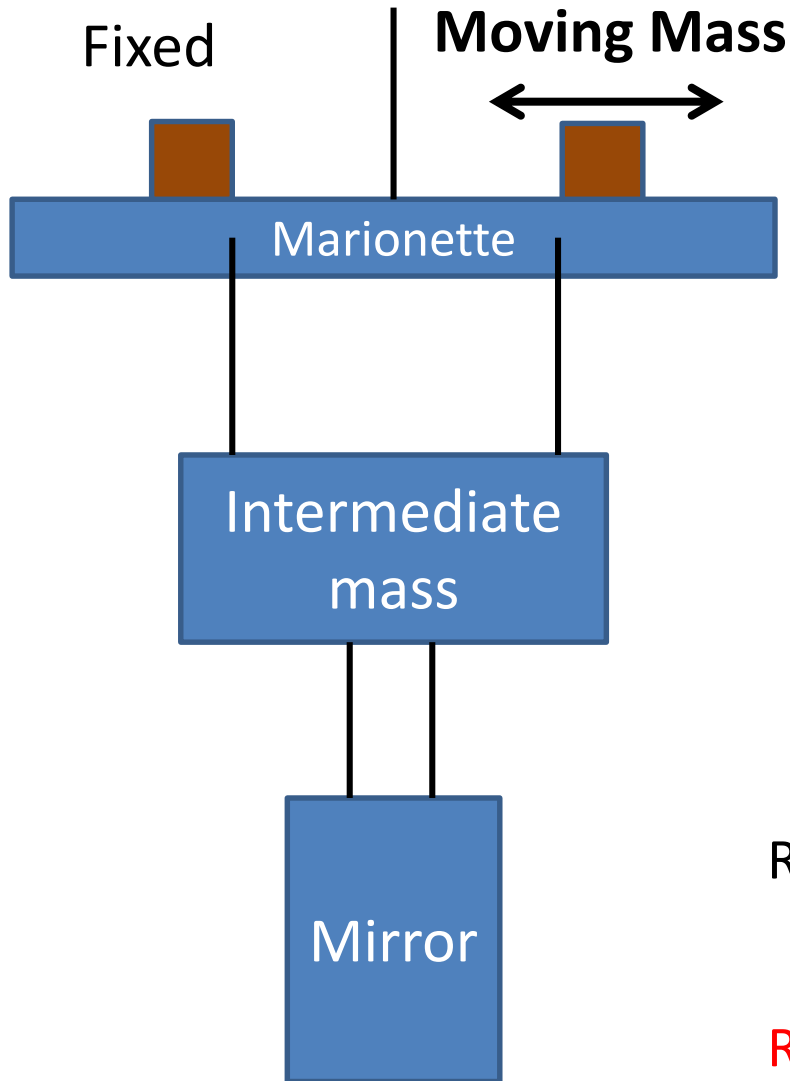

Result @ Room Temperature

Test in cryogenic temperature is on going now.

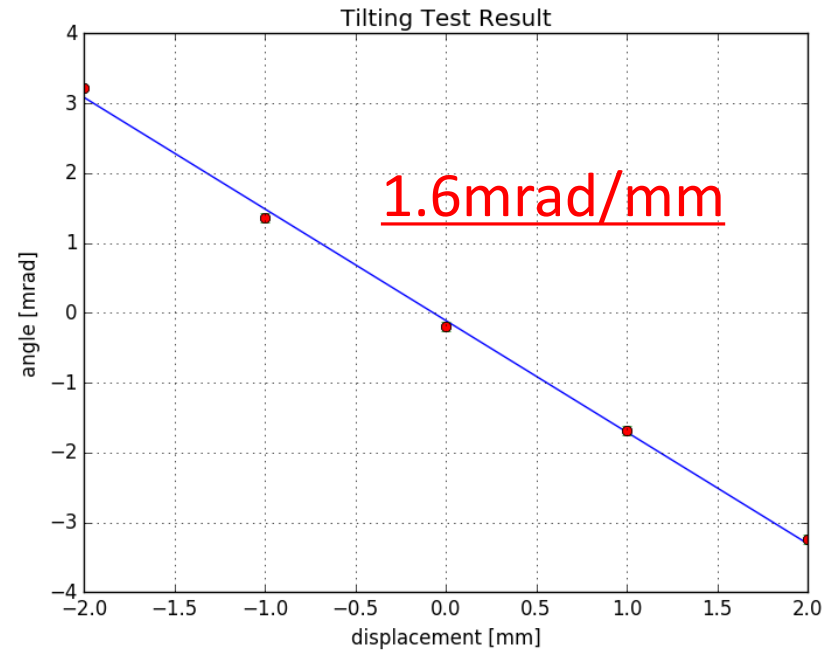

Requirement: 10 μ rad resolution
+/- 3mrad in dynamic range

Result: 0.45 μ rad resolution
> +/-3.2mrad range

Summary

- Physics of cryogenics mirror and suspension is simple.
So introduction of cryogenic mirror system should be promising in 3rd generation GW detectors.
- But its technologies are difficult.
KEK spent 20 years to develop cryogenic mirror system on the basis of accelerator science technologies.
- In the process, we developed new technologies such like *vibration free cryocooler, black coating, 6N Al conductor and stuff*.
- KAGRA is under challenging to complete cryogenic mirror system.
We are making maximum effort to start full cryogenic operation of KAGRA from early 2019.

Back Up

Goal Sensitivity of KAGRA

$$h \sim \text{factor} \times 10^{-24} \text{ [}/\sqrt{\text{Hz}}]$$

An issue in 2nd generation GW detectors:

How can we reduce thermal noises, which restrict best sensitivity range of 100Hz.

Underground

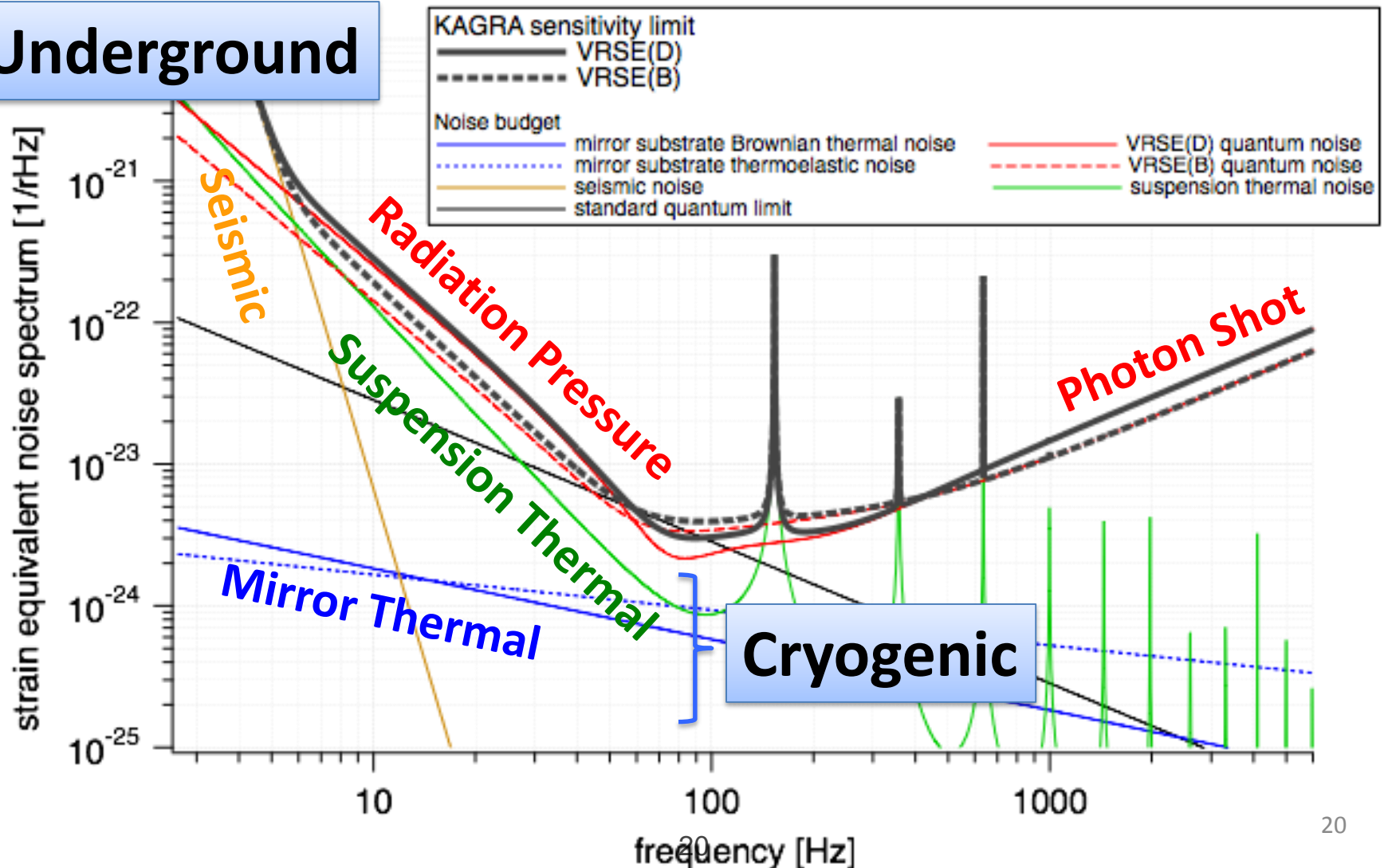

KAGRA Site



Mozumi Entrance



地下 1000m

KAGRA



Shin-atotsu Entrance



Size Effect

Size effect dominates conductivity of 6N Al thin wire at low temp.

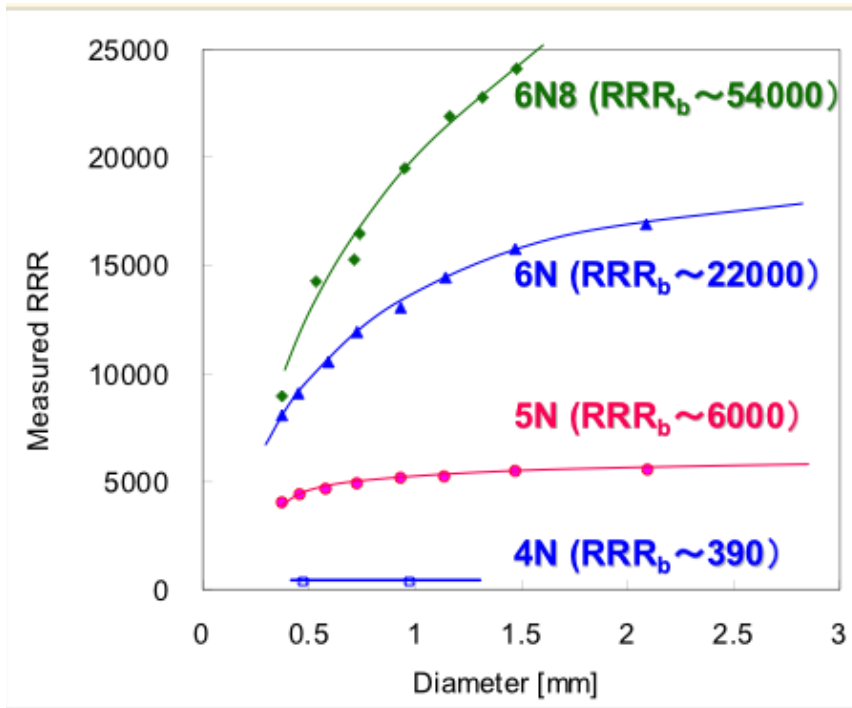

Hoshikawa et al. ICEC-ICMC 2012

Estimated thermal conductivity of 6N Al w/ $\Phi 0.15\text{mm}$ is about 17,000, which is about 1.5 times larger than that of 5N Al.

Estimated RRR

	Bulk	$\Phi 1.0\text{mm}$	$\Phi 0.15\text{mm}$
6N	~22,000	~14,000	~4,000
5N	~6,000	~5,000	~2,700
4N	~390	~390	-

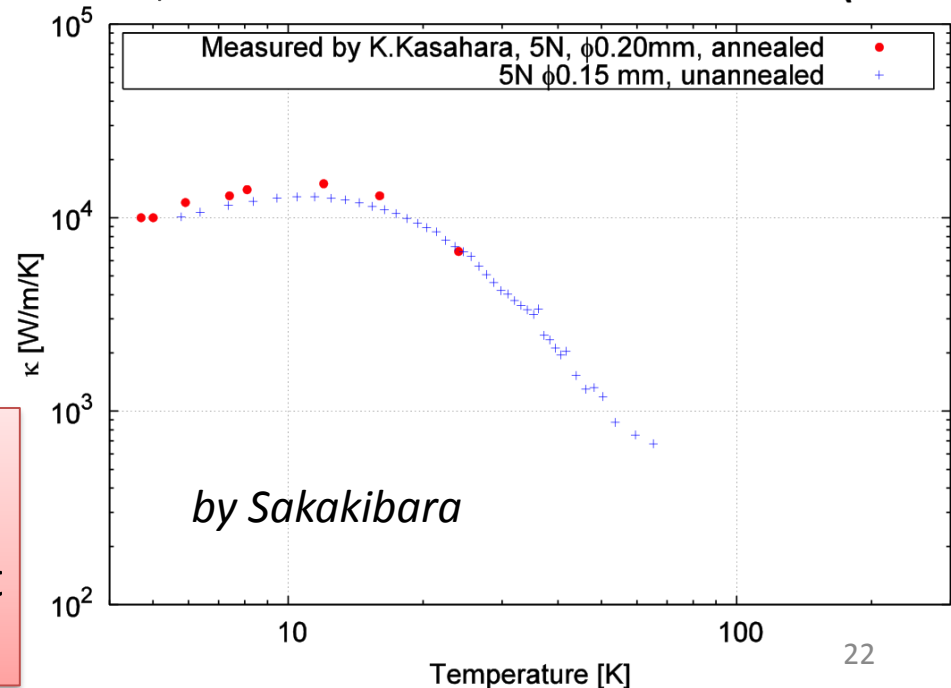

アウトガスの小さな樹脂材料と熱処理

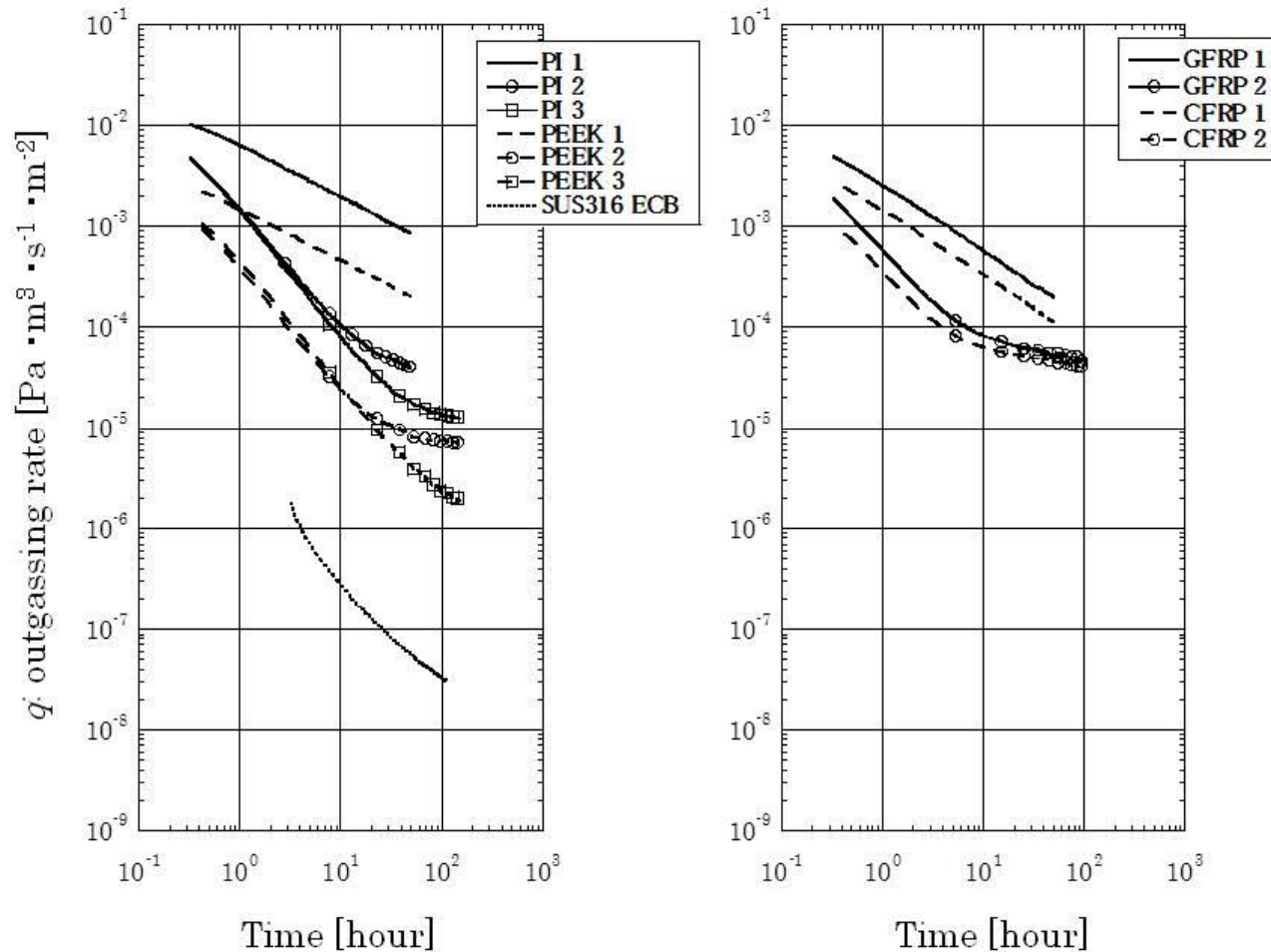

PI1、PEEK1、GFRP1、CFRP1は十分に飽和している状態、
PI2、PEEK2は200°Cで10時間の熱処理を2回行った状態、
PI3、PEEK3は200°C、8時間の熱処理を5回行った場合
GFRP2およびCFRP2は、80°C、8時間の熱処理を行った場合

加速器の極低温・超高真空技術

粒子加速器科学では、超伝導電磁石や超伝導加速器などで用いる極低温・超高真空技術が発展しており、これらの技術をベースに低温干渉計型重力波検出器の研究が実施された。

KAGRA



J-PARC ニュートリノ
超伝導ビームライン

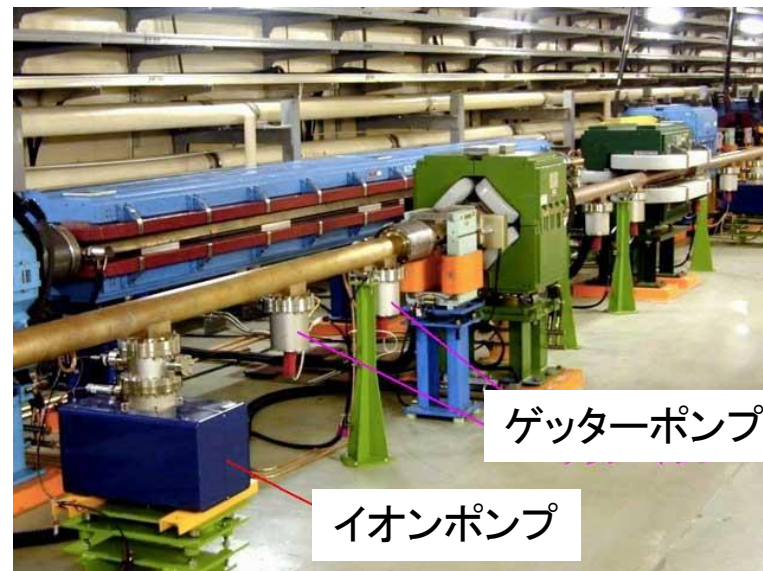

ゲッターポンプ

イオンポンプ

Installation Tools

Y-end: Done
X-end: This FY

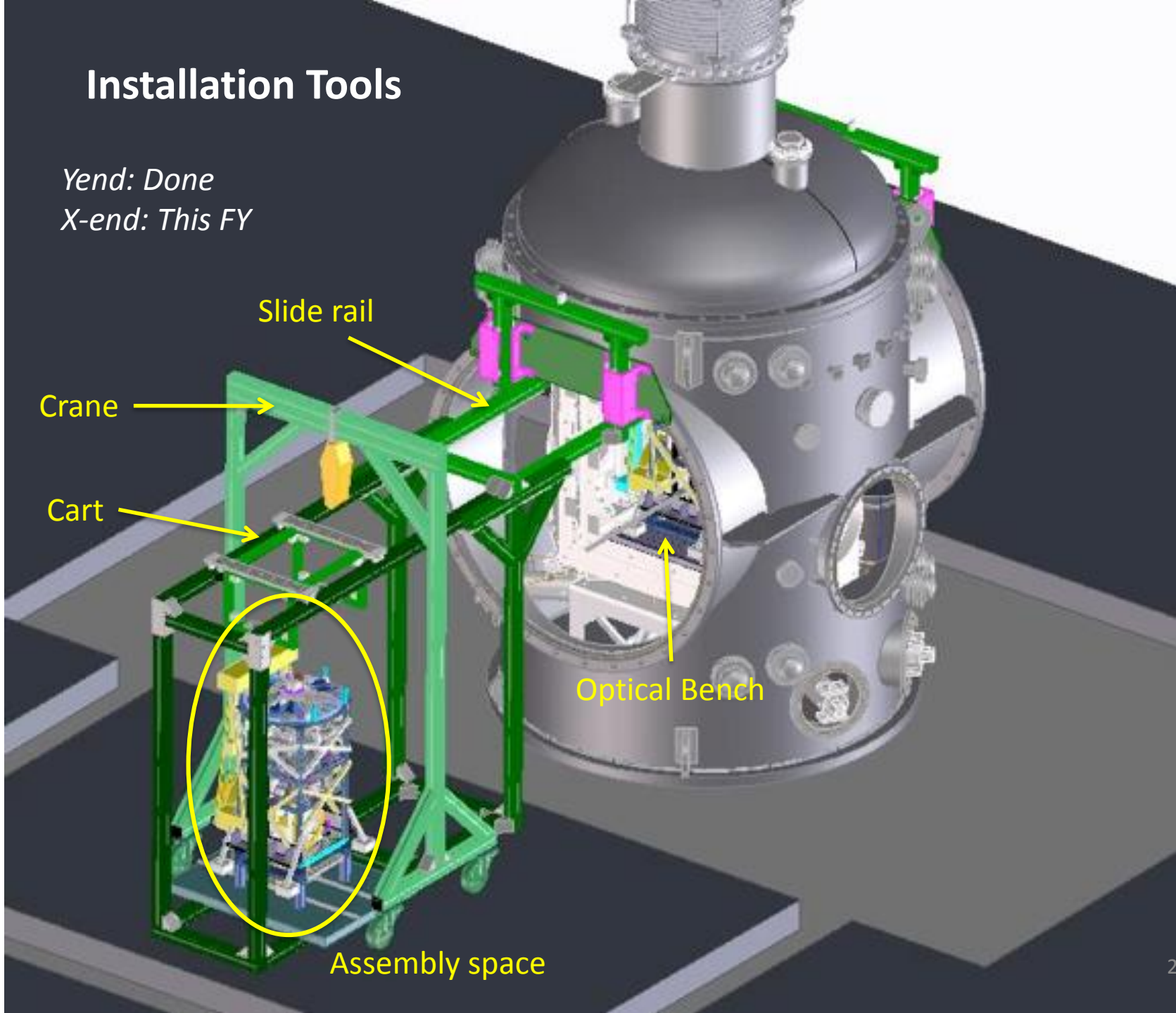

Slide rail

Crane

Cart

Optical Bench

Assembly space

Heat Link Installation

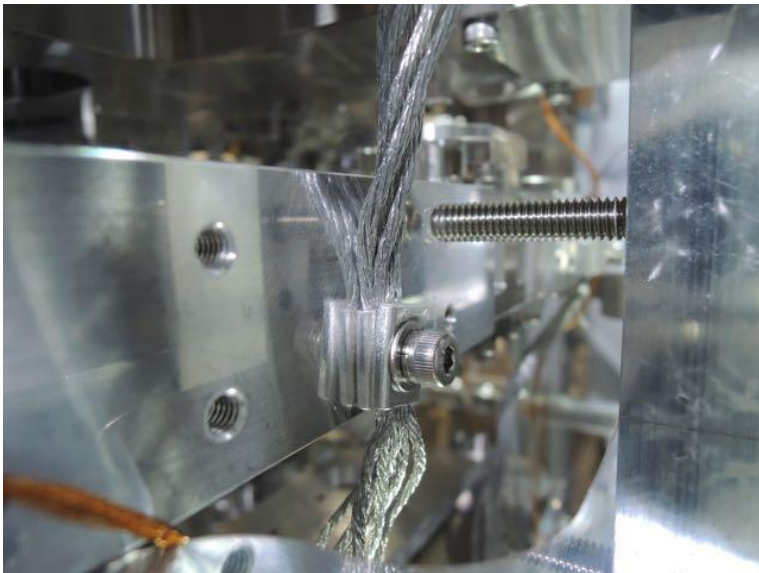
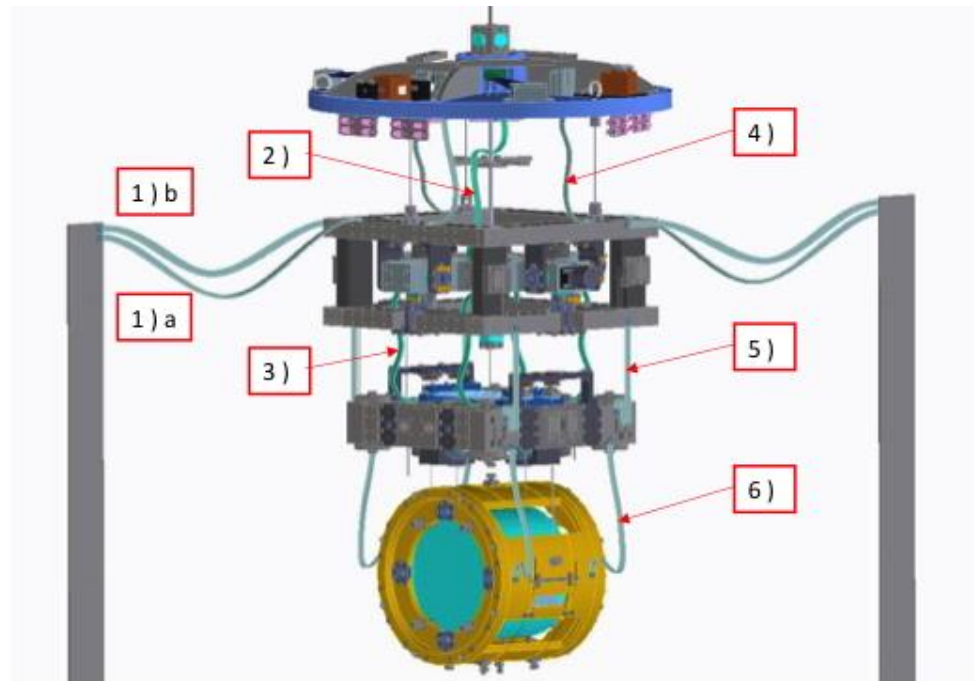
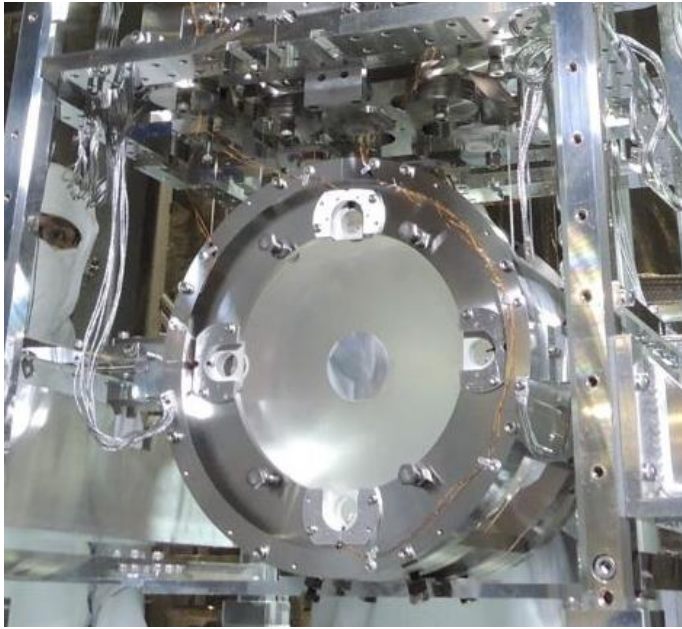

(2) 材料

アウトガスの小さなSuper Insulator の開発

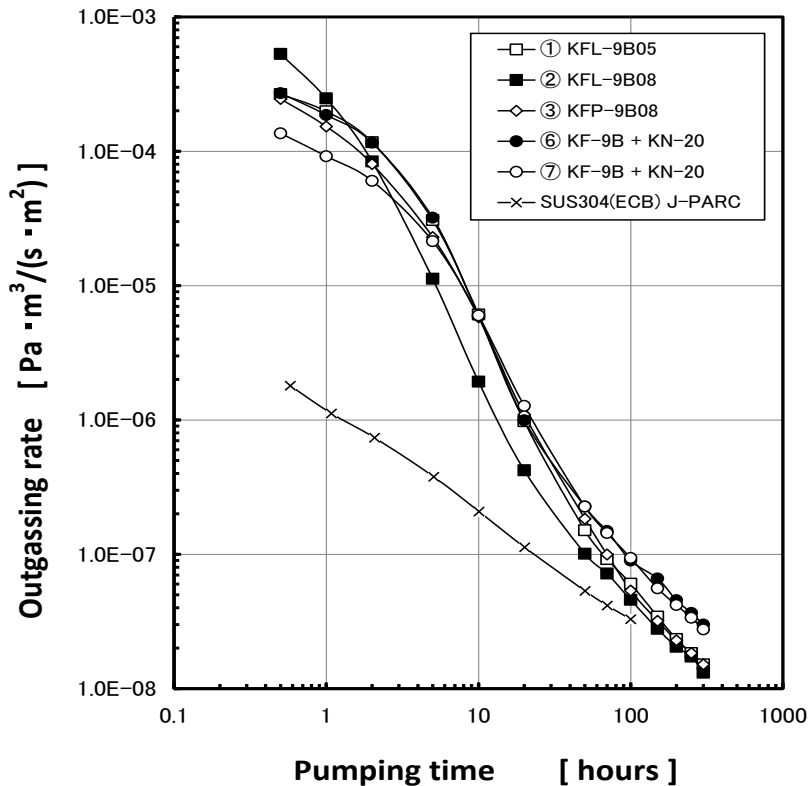

ガス放出速度測定

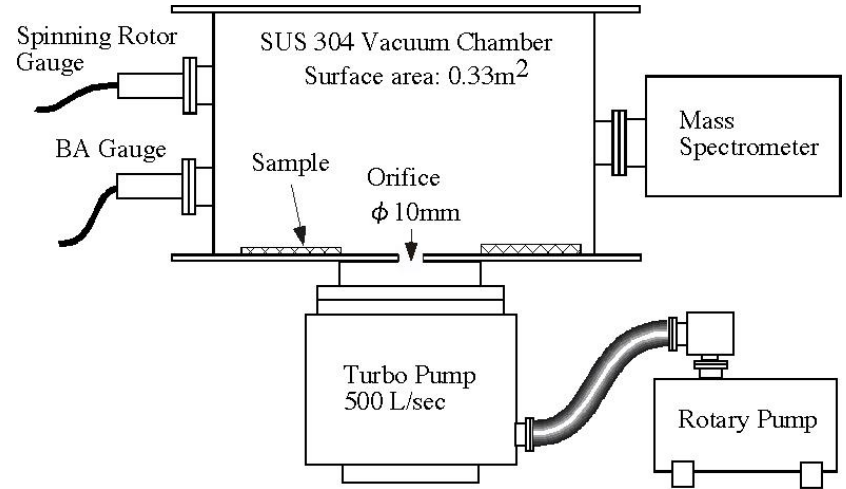

コンダクタンス変調法

低温工学 26 (2011) p408

真空ジャーナル (2015) p11-17

図9 断熱多層フィルムMLIのガス放出速度測定結果[12]。KFL-9B05、KFL-9B08、KFP-9B08は新しく開発した薄型のMLIで、それぞれ $5\mu\text{m}$ 、 $8\mu\text{m}$ 、 $8\mu\text{m}$ のpolyesterフィルム両面にアルミ蒸着し、片面にはpolyester繊維をスペーサーとして溶融させたものである。KF-9B + KN-20はpolyesterネットスペーサーを用いた従来型MLIのガス放出速度であり、⑥、⑦はそれぞれシリカゲルと共に2年間保管していたものと購入直後のものである。

Small-Outgas Super Insulator

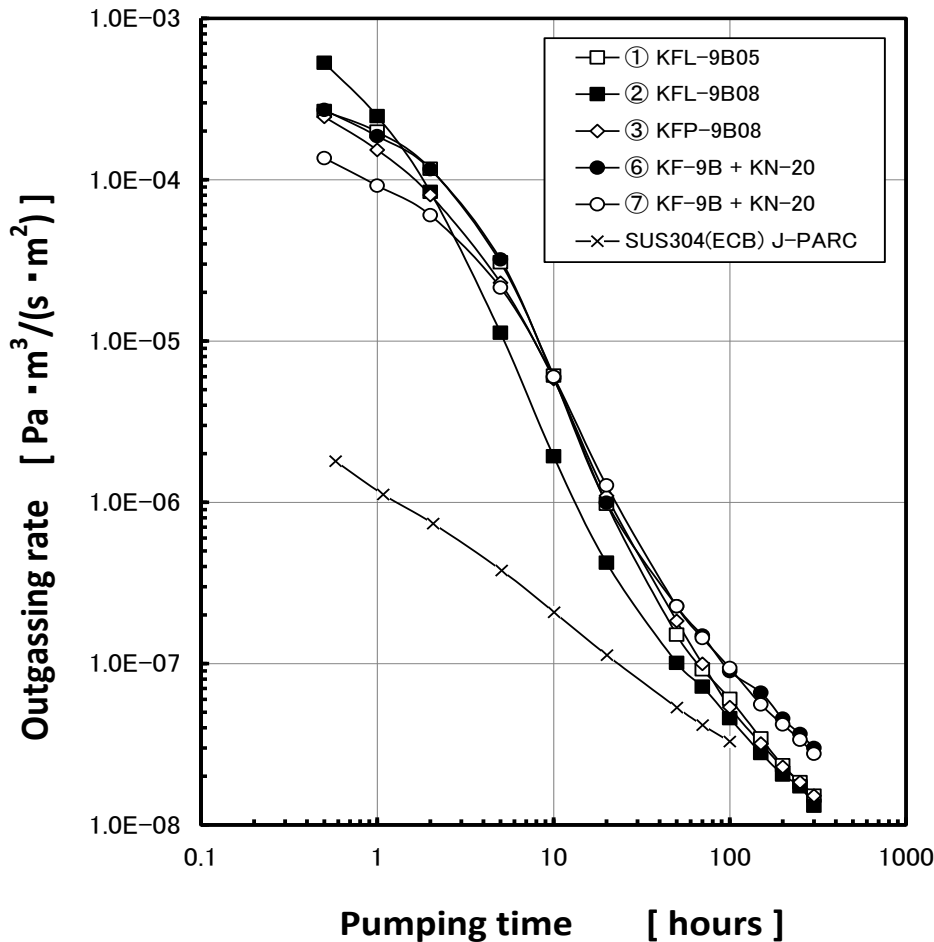

Outgas measurement

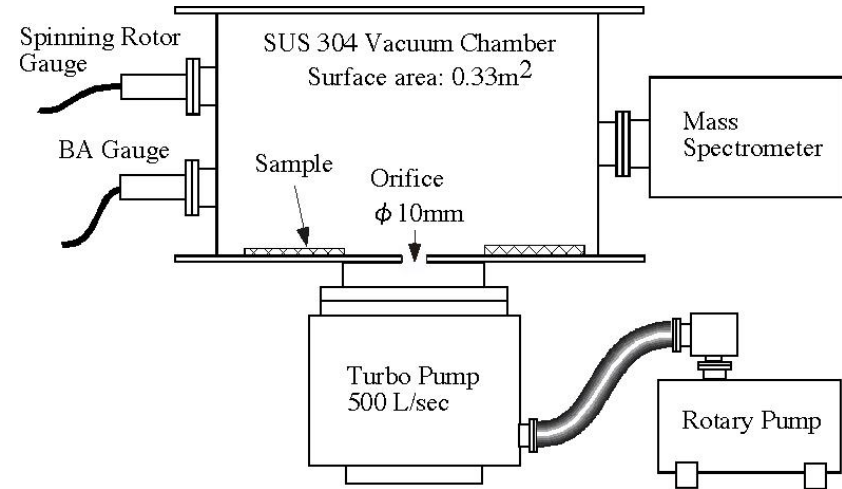

Conduction Modulation Method

*Teionkougaku***26** (2011) p408
Shinku Journal(2015) p11-17

The samples of KFL-9B05、KFL-9B08、KFP-9B08 are new developed MLI. Each samples has both side Al coating and single-side fiber spacer on polyester film of $5\mu\text{m}$, $8\mu\text{m}$ and $8\mu\text{m}$ in thickness, respectively. The KF-9B + KN-20 sample is a typical MLI with polyester-net spacer.

Vibration Measurement Result in X-front Cryostat

Large vibration was found btw 10 and 100Hz region.
These vibrations look to correspond to structural resonance of cryostat.
But still under investigation.

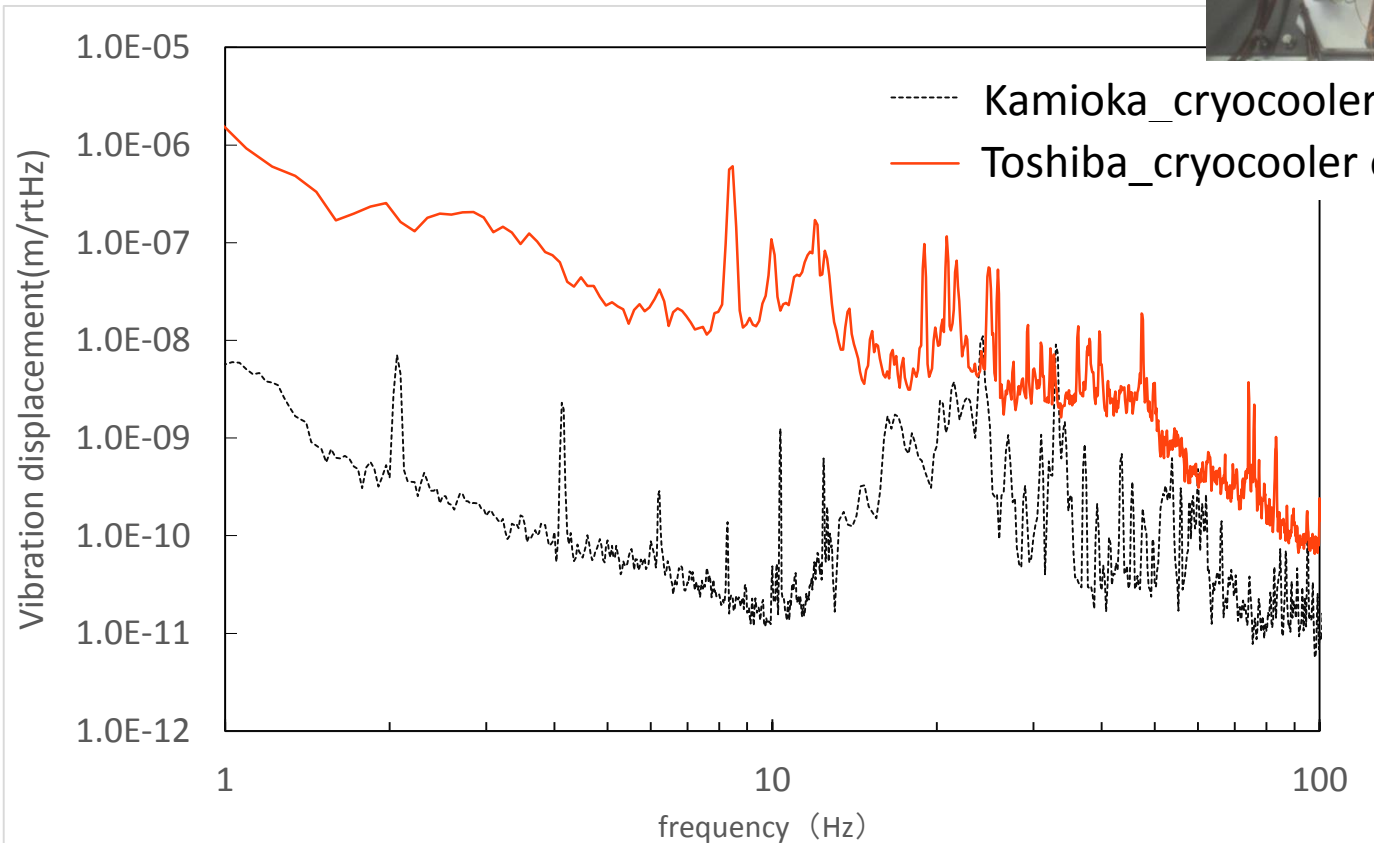

***Collaborated
by Roma Univ.
based on
ELiTES program***

TM Displacement Noise from Act

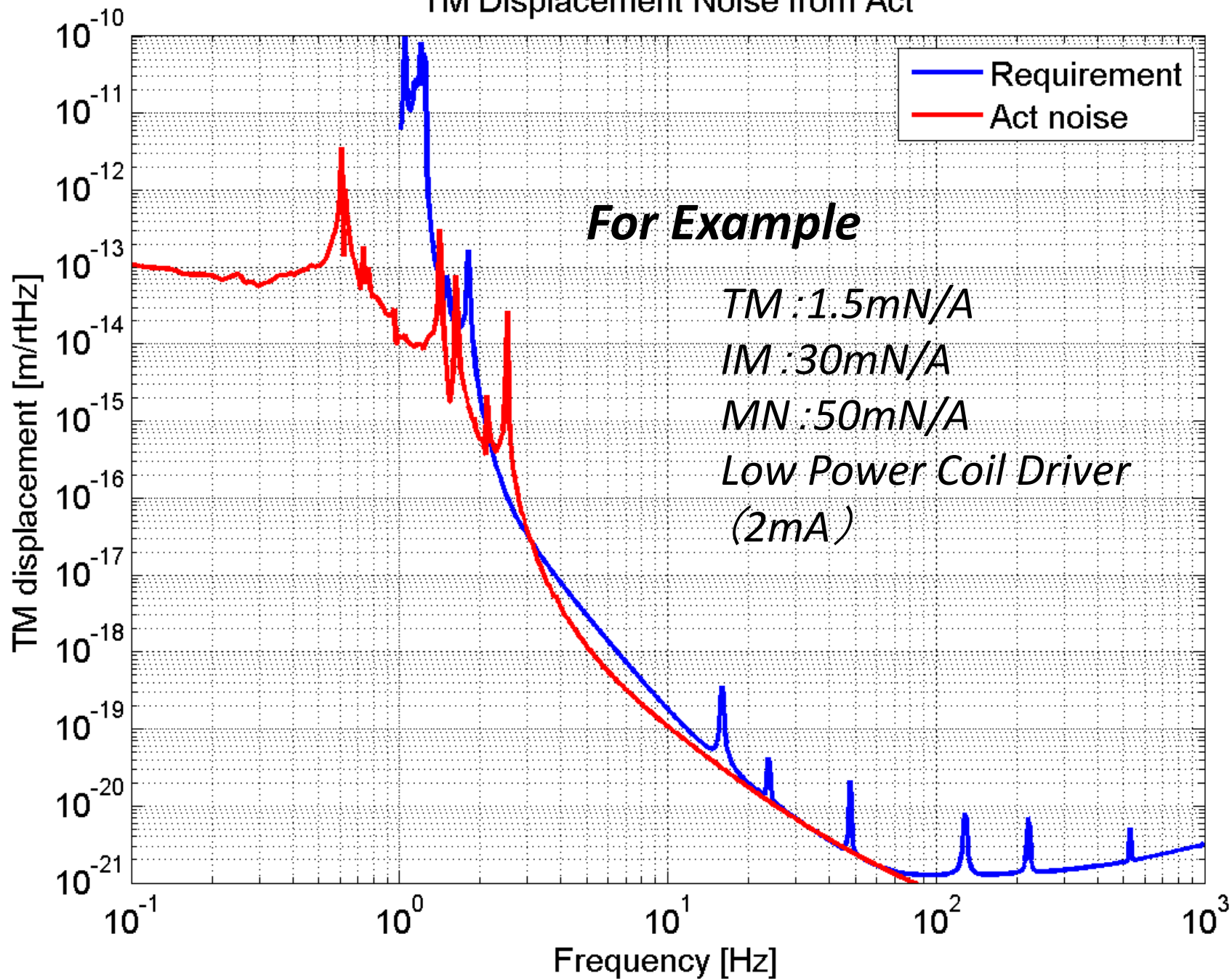

Cooling Down of EYC Cryostat

Aug, 26, 2017
KAGRA Cryogenics Team

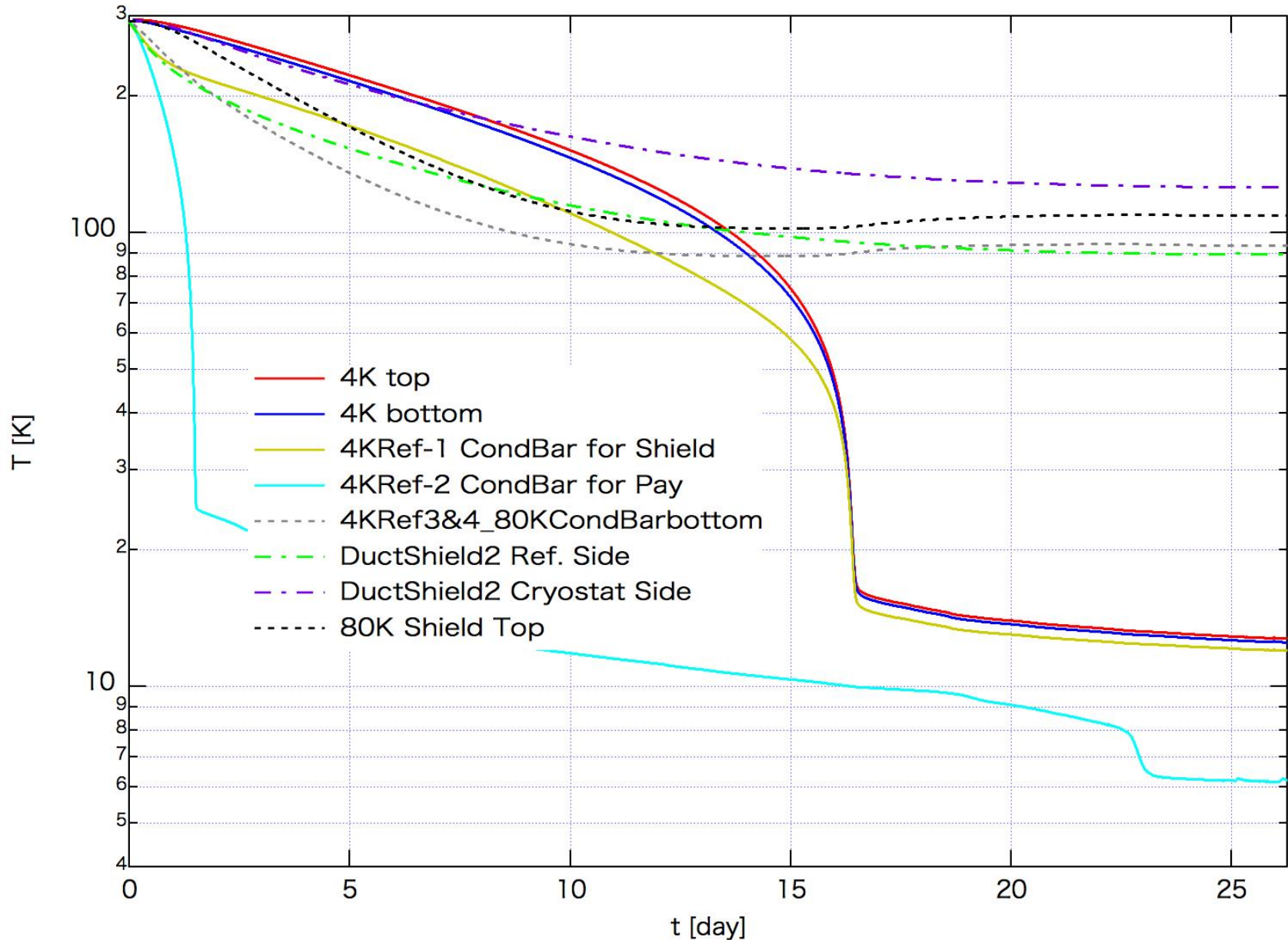

Cooling Down

in 6:40pm, Aug. 26, 2017

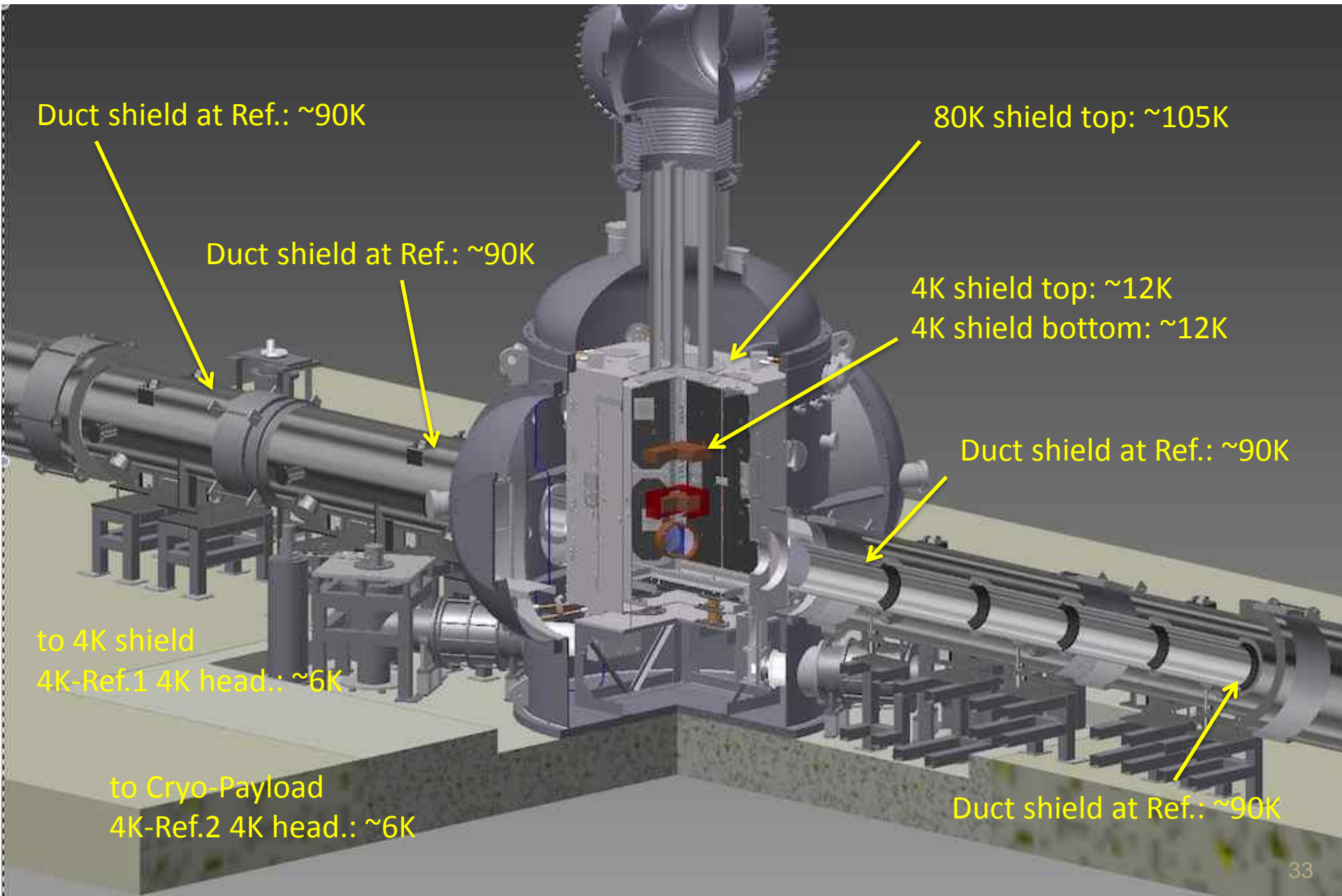

Cooling Down

on Aug. 26, 2017

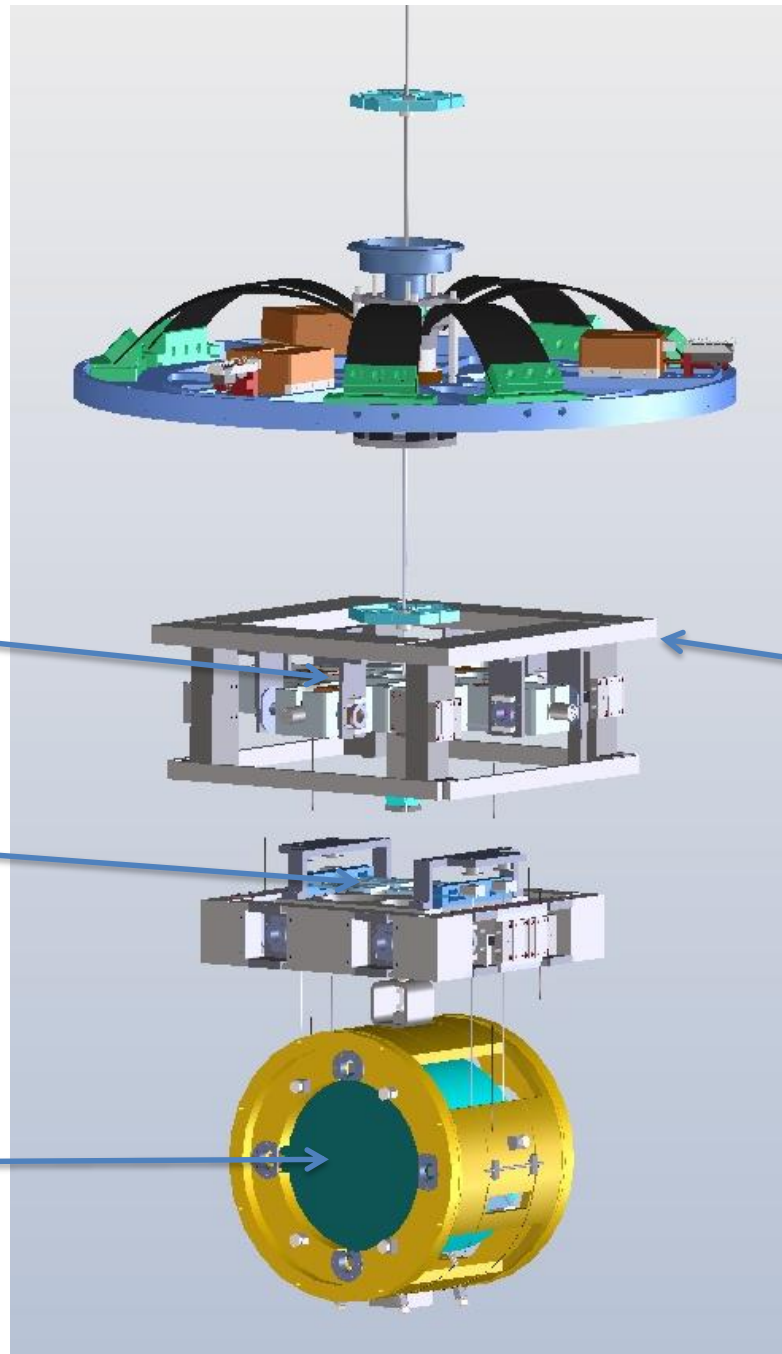

Frame: ~12K

Marionette: ~12K

Marionette
Recoil mass:
~12K

Intermediate Mass:
~12K

Mirror:
~14K

Tilting Test Result of Cryo-Payload @300K

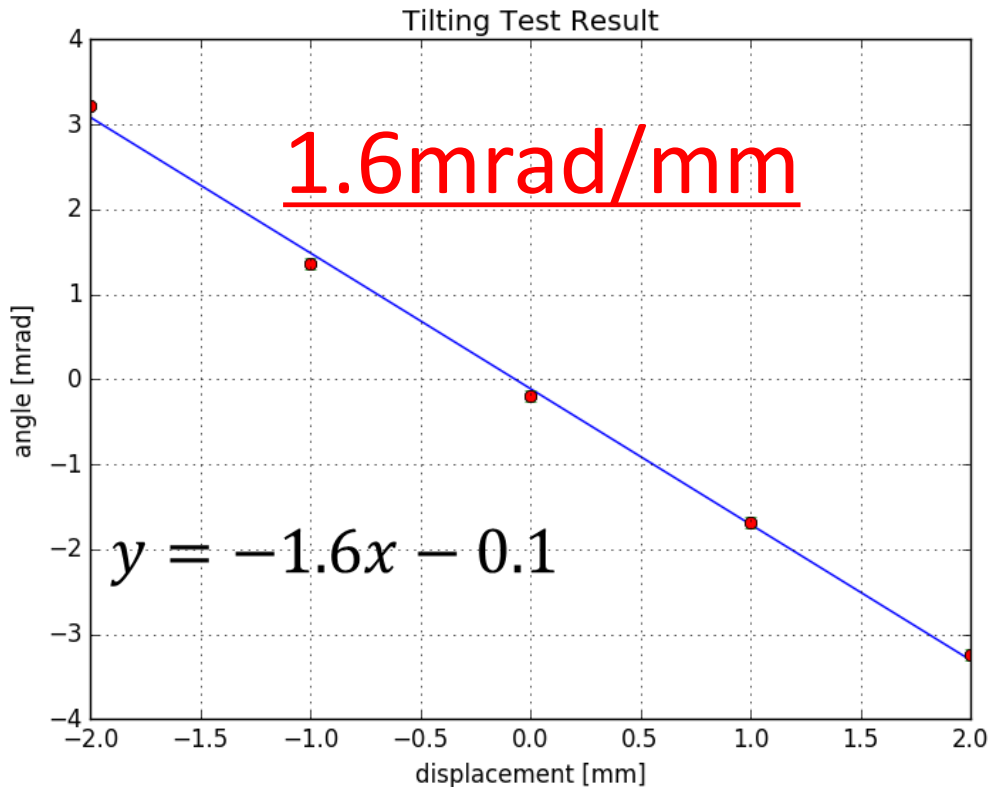

Moving Range: +/- 15mm



Maximum tilting: +/- 24mrad
(Requirement: +/- 3mrad)

One step of motor: 0.09°
Screw Pitch: 1mm



Tilting Resolution: 0.4urad
(Requirement: 10urad)

We plan to have a cryogenic test in this December.