

3x1x1 operations: Problems found and possible explanations

Laura Manenti & Laura Molina Bueno

Delivered

Work in progress

Issues found

1) CRP mechanical frame and suspension system:

- Functioning of the automatic frame adjustment system: Will be tested in the following weeks.
- Calibration procedure of level meters.
- Resolution of level meters and their stability over time.
- Planarity of the frame in cold conditions

2) LAr level measurement precision: long coaxial LM (next to drift cage and in pump tower), PT100s ribbon chain, plate capacitors around CRP and drift cage, level measured using cameras.

- How do they compare to each other in terms of accuracy and precision?
- Cameras: are we satisfied with the number of cameras, their location in the cryostat and their performance at cold?
- Plate capacitors around CRP: are these sufficient? Do we need more? Are we satisfied with their size, i.e. optimal shape and size of the level meters.

3) Very High Voltage system and feedthrough:

- Long-term voltage sustainability of the feedthrough.
- Stability of the voltage and the current as a function of time of the entire VHV system in general.
- Monitoring of current and voltage: in the following weeks we will change to the 100kV
- Fiducial volume and uniformity of the drift field.

4) High voltage system:

- CAEN power supply stability over time.
- Improvements foreseen: Need for a current limiting resistor for the LEMs. We are investigating if can be included in the board. Ideally one serial and one parallel resistor per LEM
- Need for filter and/or resistor to ground.
 - We observed an increase of the noise when we removed the serial resistor because was acting as filter. (Final test will be done in the following weeks)
 - We plan to do a check ground connection

5) LEM, anode and extraction grid

- LEM performance: maximum gain achieved and gain stability over time and position dependence of the gain.
- Extraction efficiency and position dependency,
- Charge attenuation and cross-talk.

Due to the grid performance we could not scan the induction field and the amplification field across the LEM, and therefore explore the maximum effective gain that can be achieved.

6) FE electronics:

- Low level noise and grounding optimisation at warm.
- Cryogenic operation of the front end electronics
- Insertion and extraction of the blades at warm.
- Temperature inside the SGFT: Stability of the temperature with and without electronics on.
- Operation of the DAQ and timing system.
- Setting up of the online and storage farm.
- Operation and performance of the electronics at different detector conditions.
- Signal attenuation in 3m view to the 2.2 nF decoupling capacitor.
- Card counter reaction under investigation.

7) PMTs:

- positive HV vs negative HV.
- self trigger vs CRT trigger mode.
- data/MC comparison through light maps: We first need to correlate with the charge events.
- gain calibration of the PMTs
- slow and fast component decay times in the liquid and in the gas.
- light dependencies on the drift field

8) Detector slow control system:

- Stability over time and performance: Since the beginning of operas
- Monitoring and stability of the different sensors.

9) Performance of the muon trigger system:

- Communication with DAQ of charge readout and light readout.
- Trigger rate and efficiency.

Several HV tests and data taking campaigns performed since beginning of June at different configurations and different LAr levels.

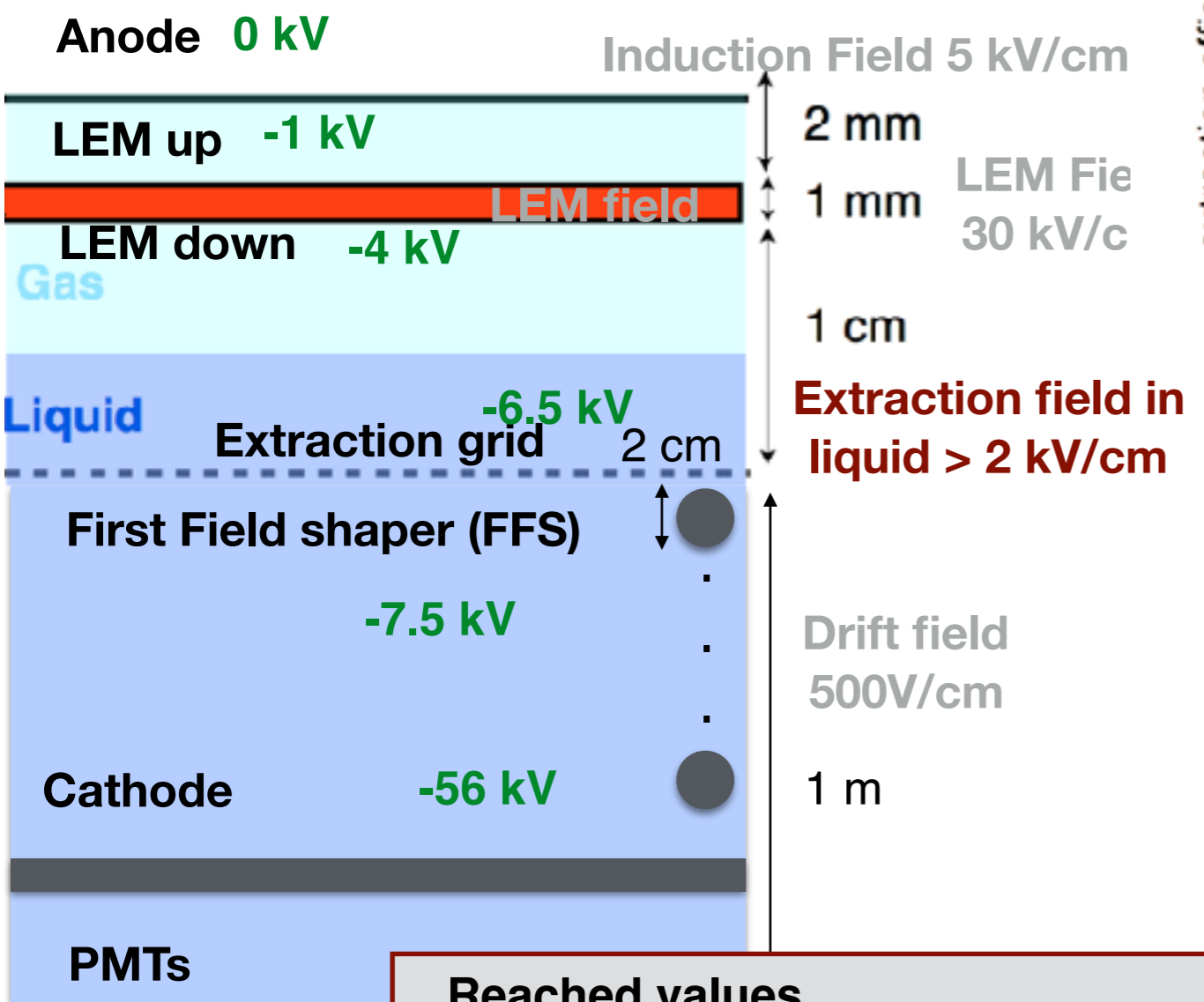

- Reached values**
- LEM field: 28-29 kV/cm
 - Extraction field in liquid: 1-2.3 kV/cm
 - Drift field 500V/cm up to 700V/cm,
 - Induction field: 1-1.5 kV/cm

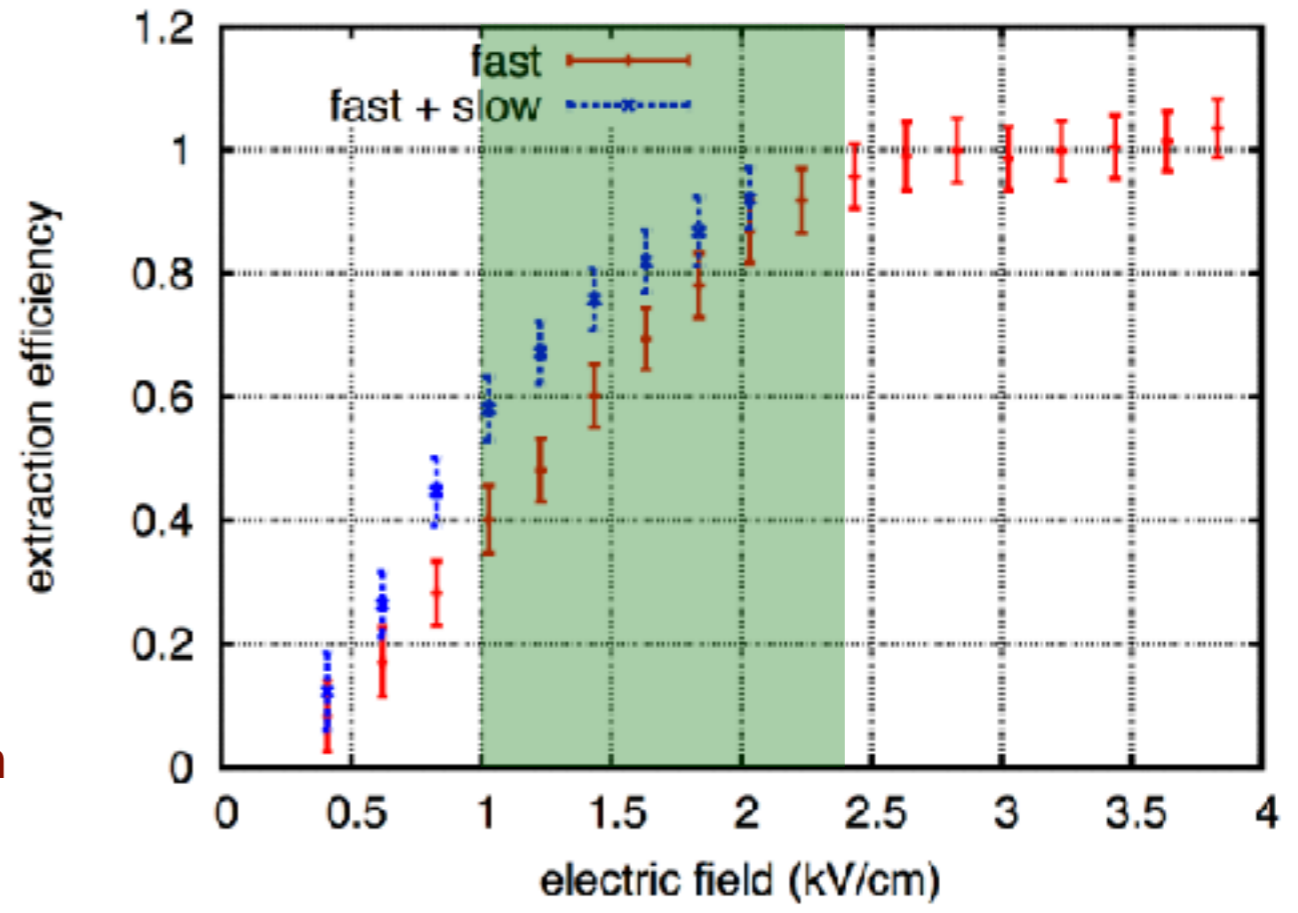

- During operations we have always stayed below the nominal operating voltages as the extraction grid trips before reaching its nominal value.
- This limits the extraction efficiency, the induction field and the field across the LEMs.
- This also limits the scan of LEM and induction field.

July 2017

Summary of achieved HV configurations

5

Case 1) Normal operation: Cathode powered with FFS connected, Grid powered, LEM down and up powered

Cathode Voltage [kV]	FFS Voltage [kV]	Grid Voltage [kV]	LEM Voltage [kV]		Drift Field [V/cm]	Extraction in Liquid [kV/cm]	Amplification [kV/cm]	Induction Field [kV/cm]	Comments
			Down	Up					
55	2.75	4.5	2.6	0.1	550	1.54	25	0.5	Highest Drift Field achieved.
48	6.5	5.3	1.9	0	480	2.99	19	0	Highest extraction while powering all the HV system.
35	4.7	4.1	3.1	0.2	350	1.53	29	1	Highest amplification achieved when powering all the HV system.
37	5	~4.0	~3.1	0.2	370	1.08	29	1	For now most stable configuration for data taking.

Case 2) Only Cathode and Grid powered.

50	6.75	5.5	0	0	500	4.8	0	0	Highest grid and FFS voltage achieved when powering only grid and cathode. Achieved with 6 mm of liquid above the grid.
----	-------------	------------	---	---	-----	------------	---	---	---

Case 3) Only Grid and LEM powered.

0	0	4.2	3.3	0.3	0	0.9	30	1.5	Highest amplification. Achieved when the cathode was not powered.
---	---	-----	------------	------------	---	-----	-----------	-----	---

Case 4) Only Grid powered.

0	0	4.6	0	0	0	4.5	0	0	/
---	---	-----	---	---	---	-----	---	---	---

4. When the grid trips, we can also have LEMs tripping. This can happen at the same time or with a delay.

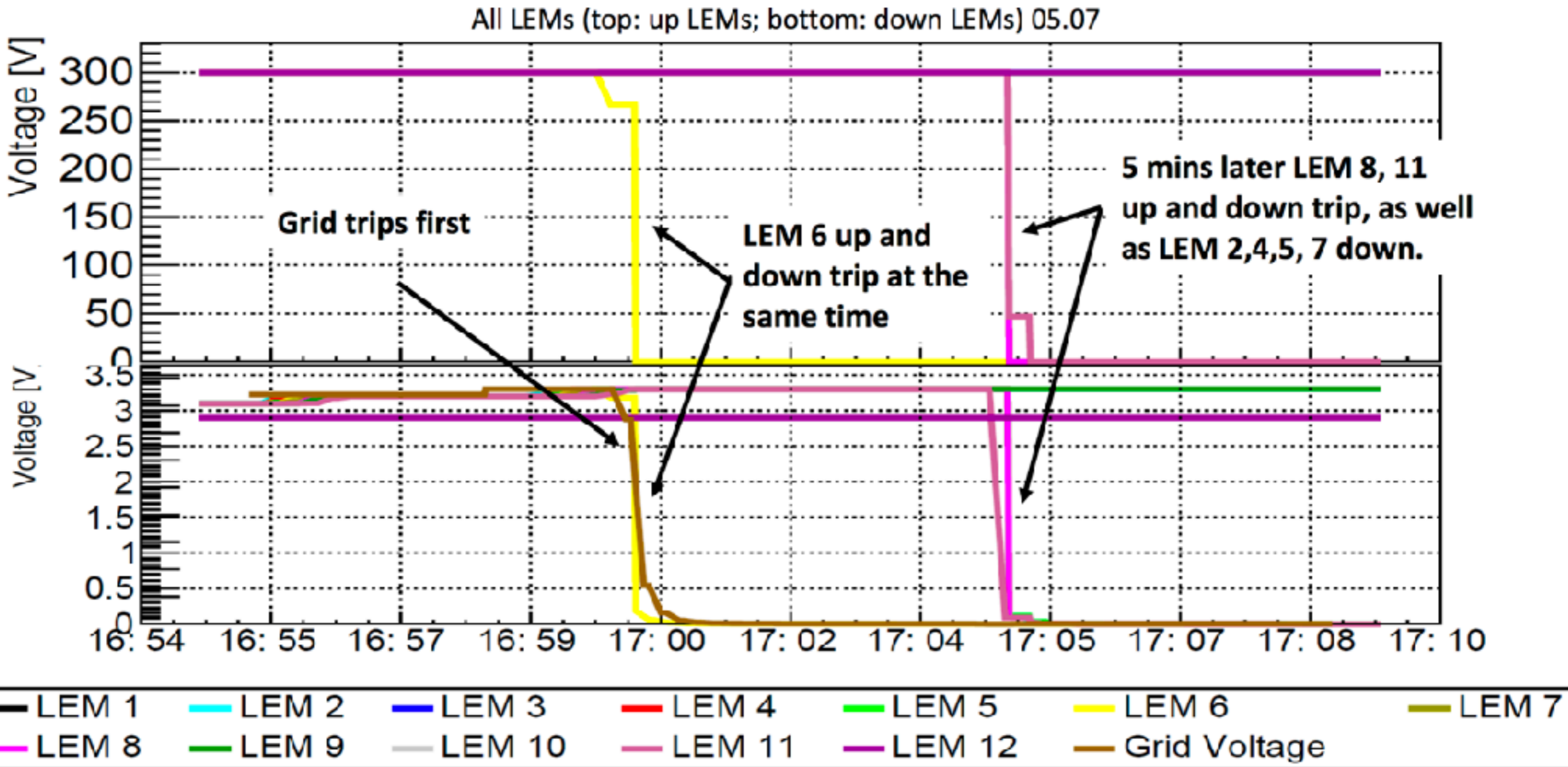

July 2017

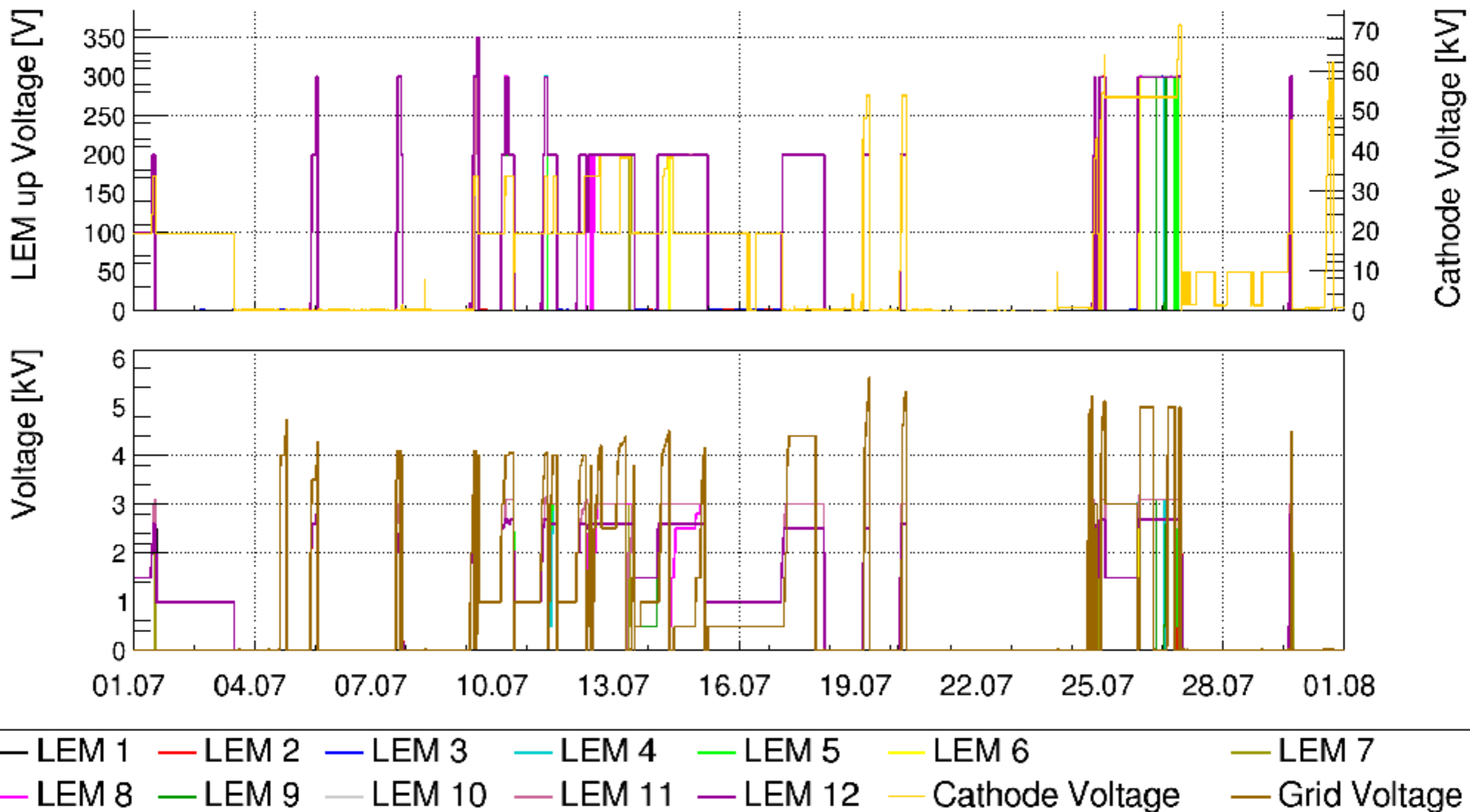

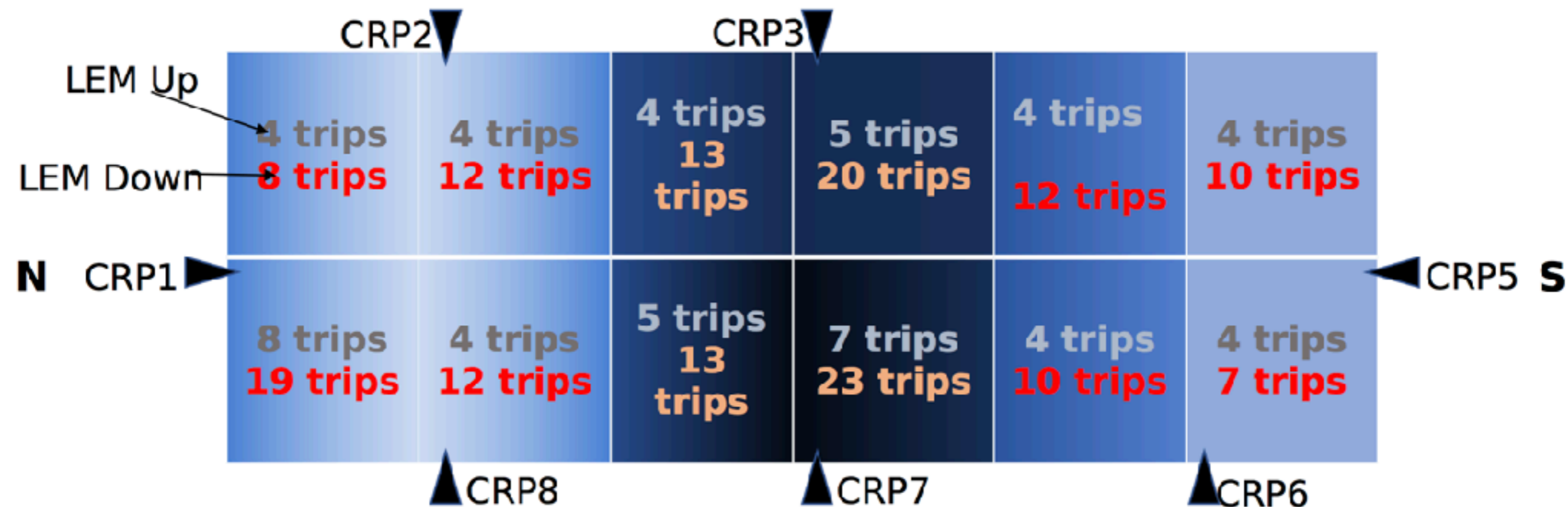

August 2017

Problem with CAEN power supply

CAEN suggested to change the board

CAEN re-calibrate the boards and repaired the one with a faulty channel

Monitoring of all the channels to verify they are all ok

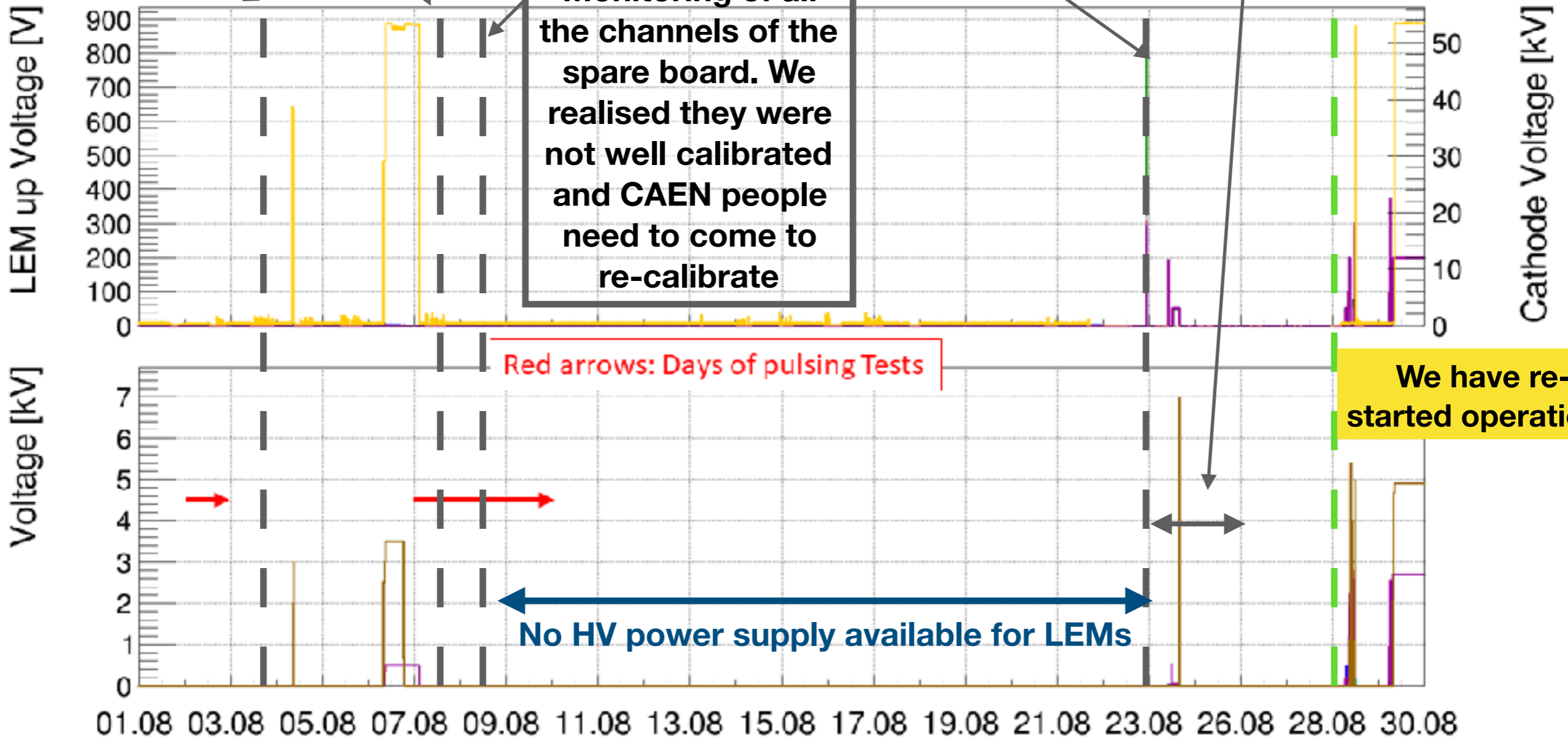

- LEM 1
- LEM 2
- LEM 3
- LEM 4
- LEM 5
- LEM 6
- LEM 7
- LEM 8
- LEM 9
- LEM 10
- LEM 11
- LEM 12
- Cathode Voltage
- Grid Voltage

All Voltages

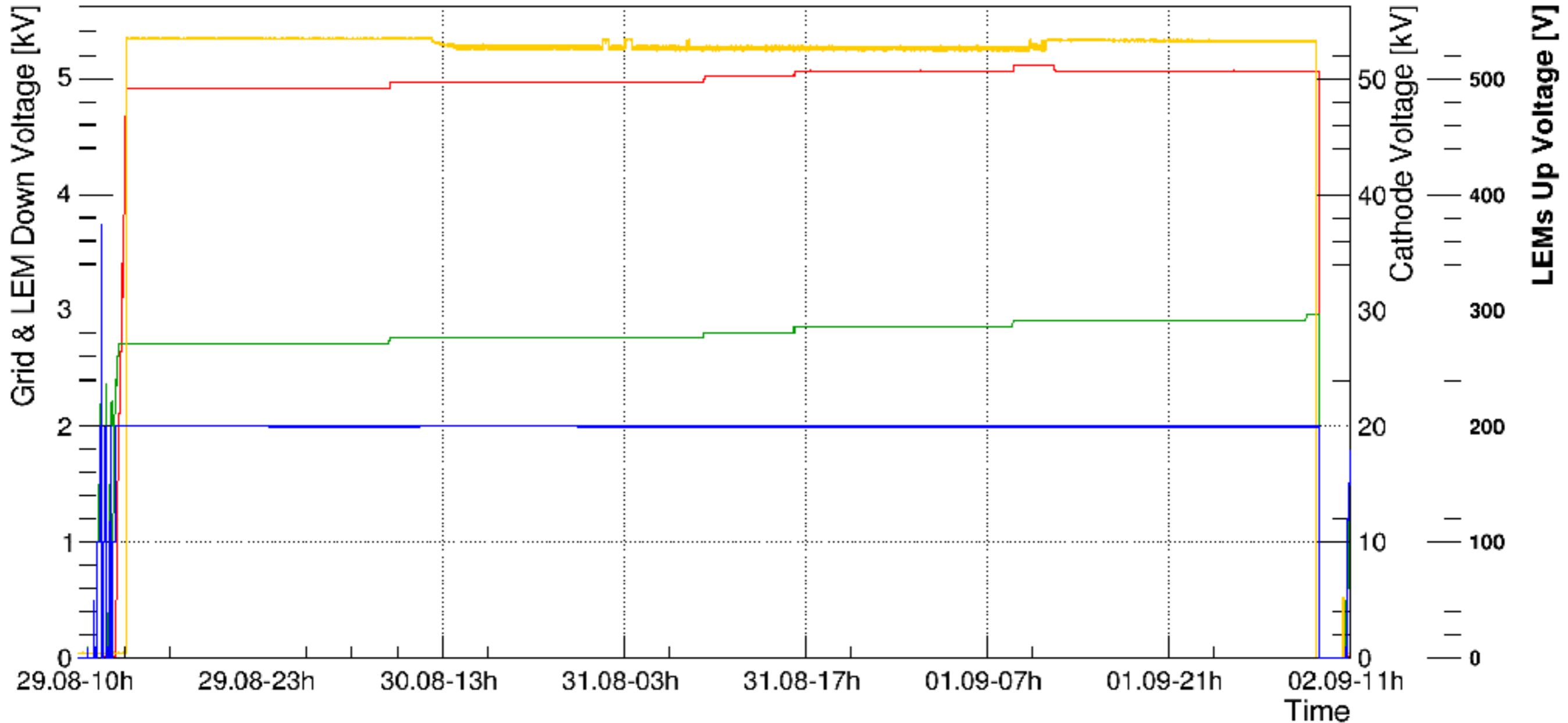

— Grid — LEMs Down — Cathode — LEMs Up

All Currents

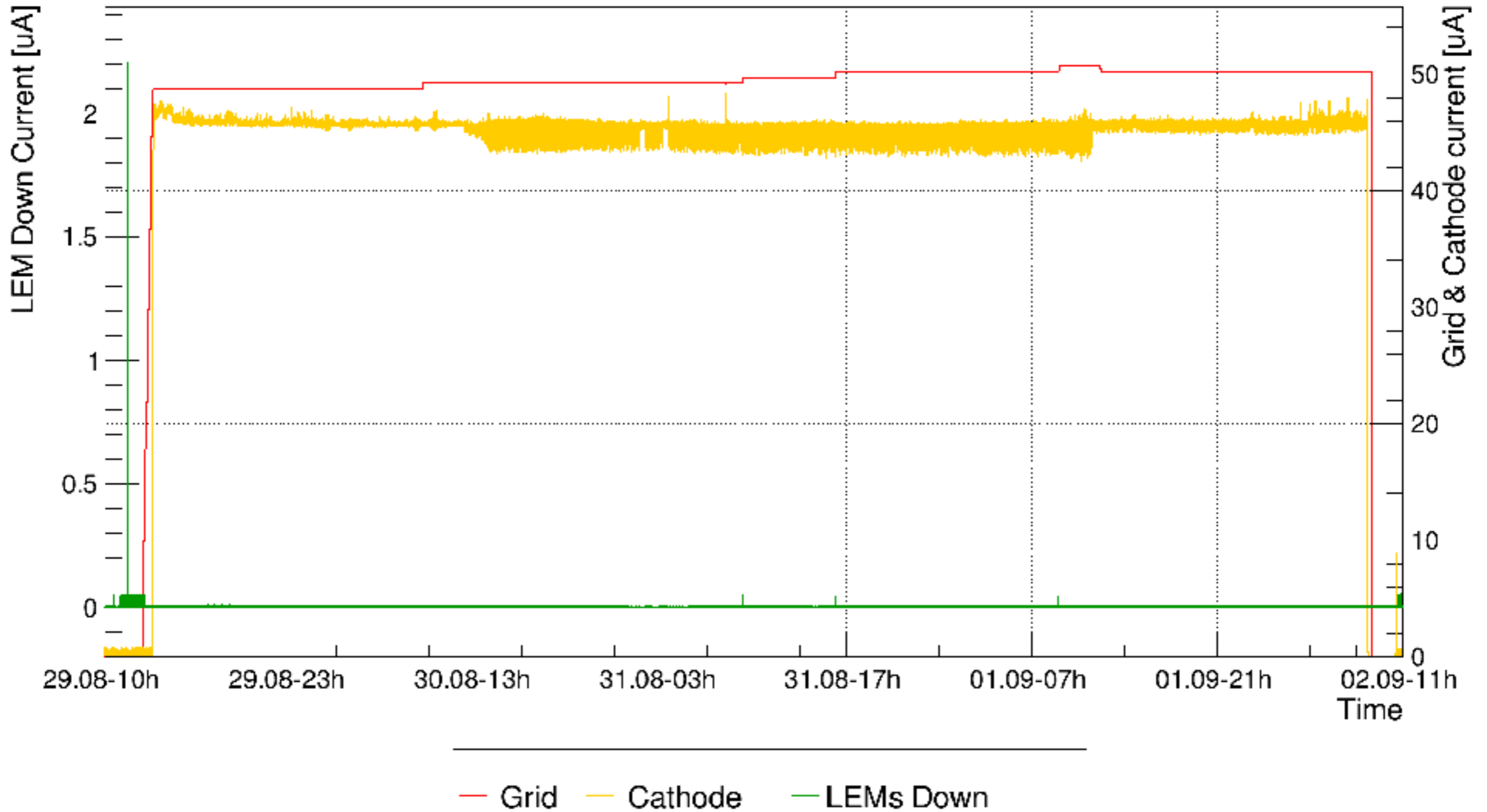

The performance was limited by the sparks of the grid from 4 kV (nominal is 6.5 kV). Possible causes which can explain this issue:

- 1. Non-planarity of the CRP.**
- 2. Liquid level value and stability.**
- 3. Sparks of the grid towards the field cage.**
- 4. Contact between the extraction grid and the LEM: for example, due to a broken/un-tensed wire.**
- 5. HV grid connection:**
 - I. It could be a problem with the HV kapton cable inside
 - II. The HV connector itself inside
 - III. The SHV connector of the HV flange.

1) CRP planarity

On June 9th the CRP position was adjusted to its nominal level.

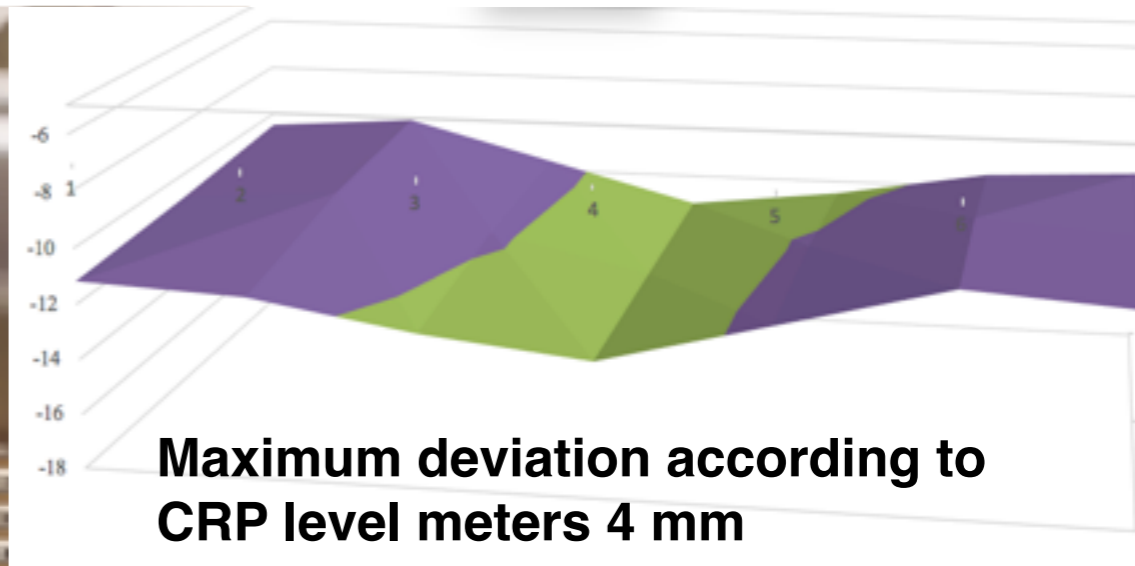
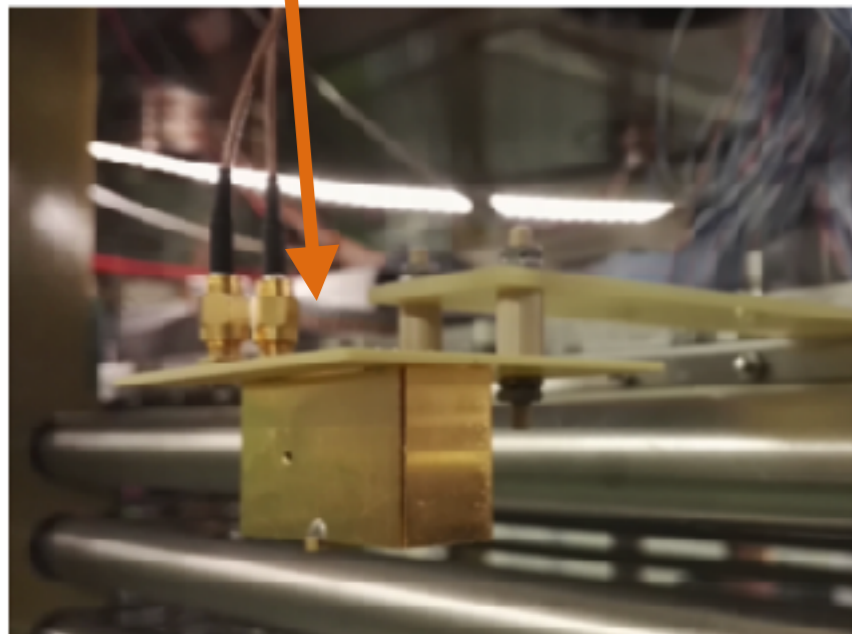
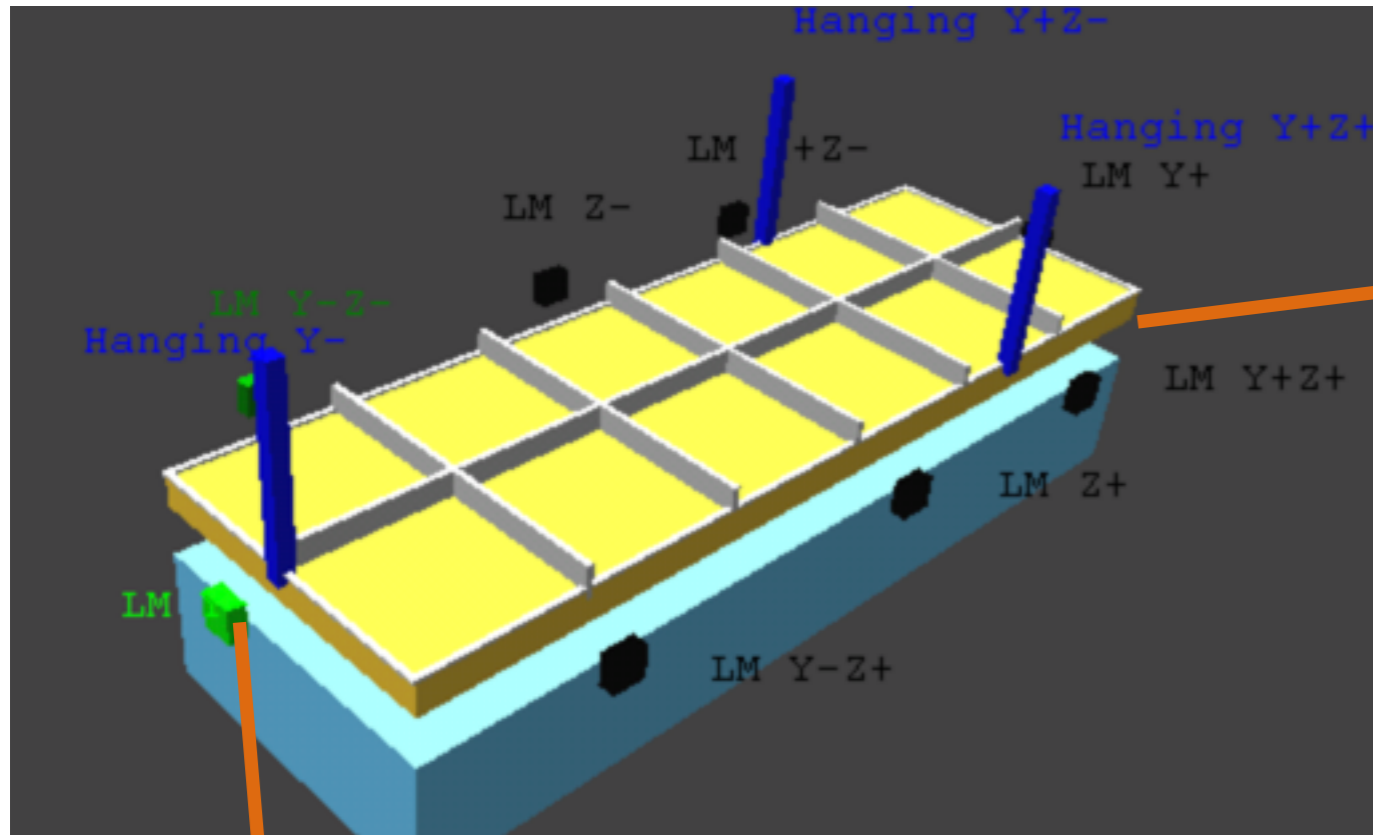

Is the grid completely immersed along the whole CRP?

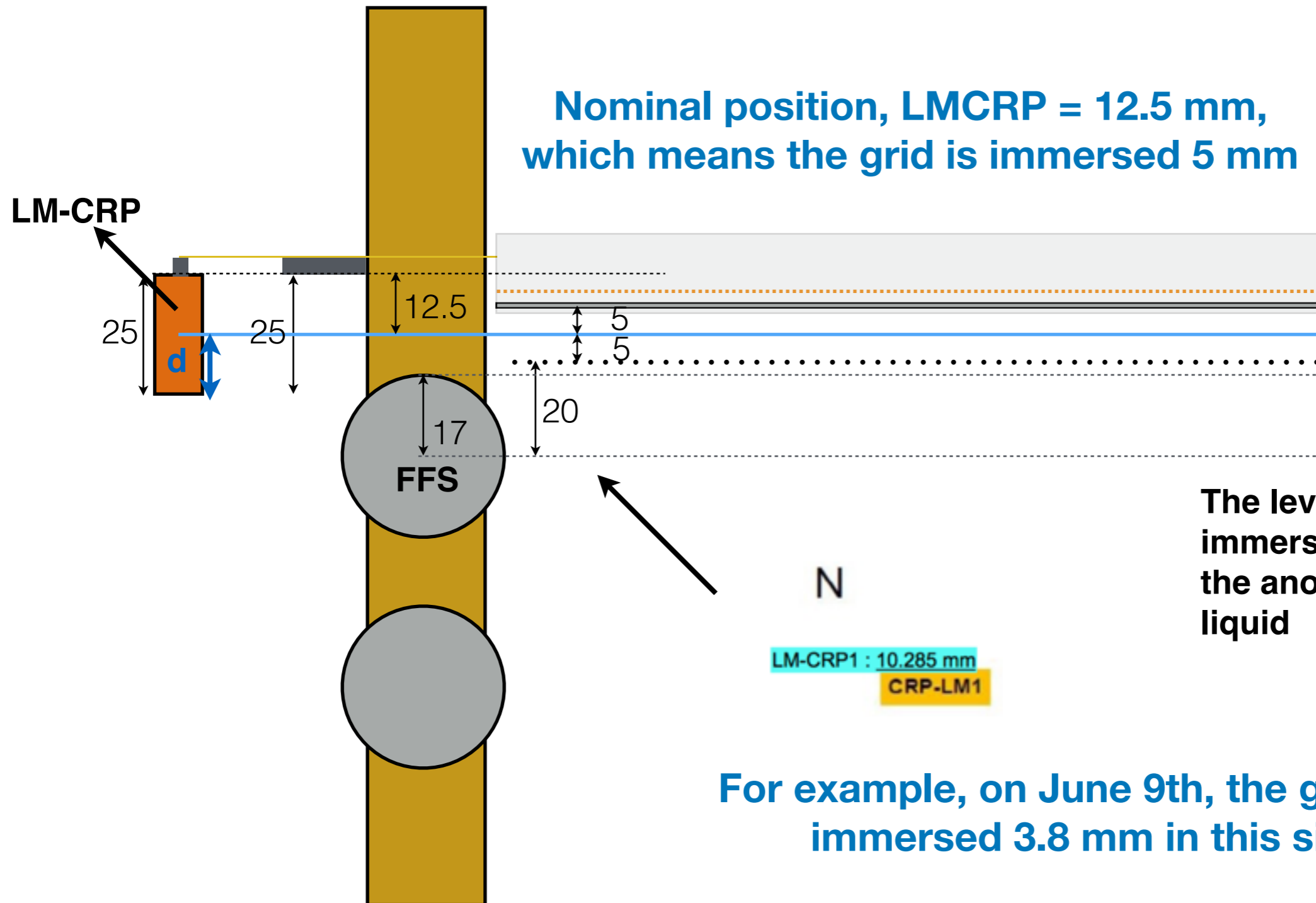

The level meter is completely immersed when the LEM and the anode are immersed in liquid

For example, on June 9th, the grid was immersed 3.8 mm in this side

The maximum voltage reachable on the grid depends on the liquid level.

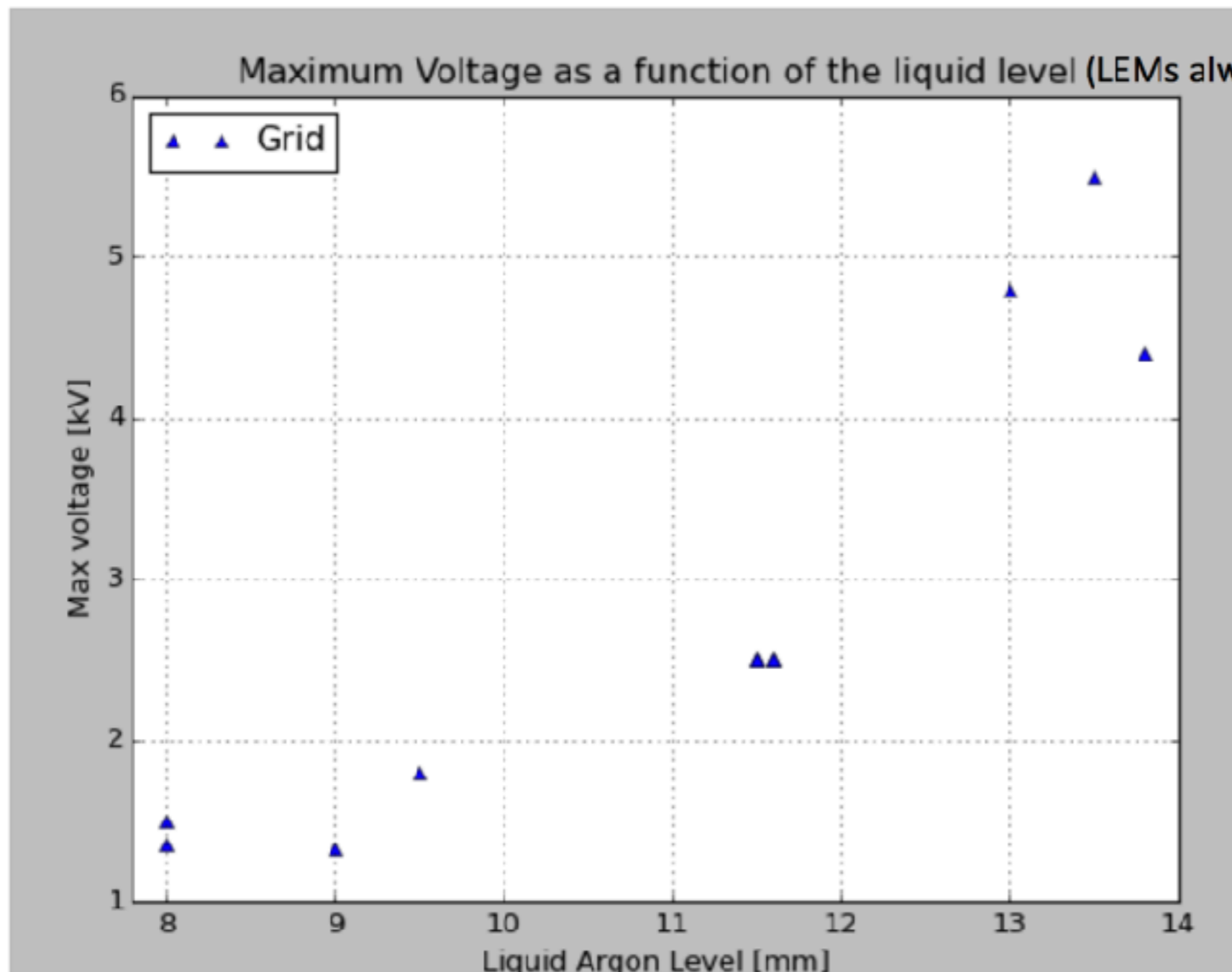

We need to have at least 5 mm of liquid above the grid to reach voltages larger than 4 kV.

1) CRP planarity

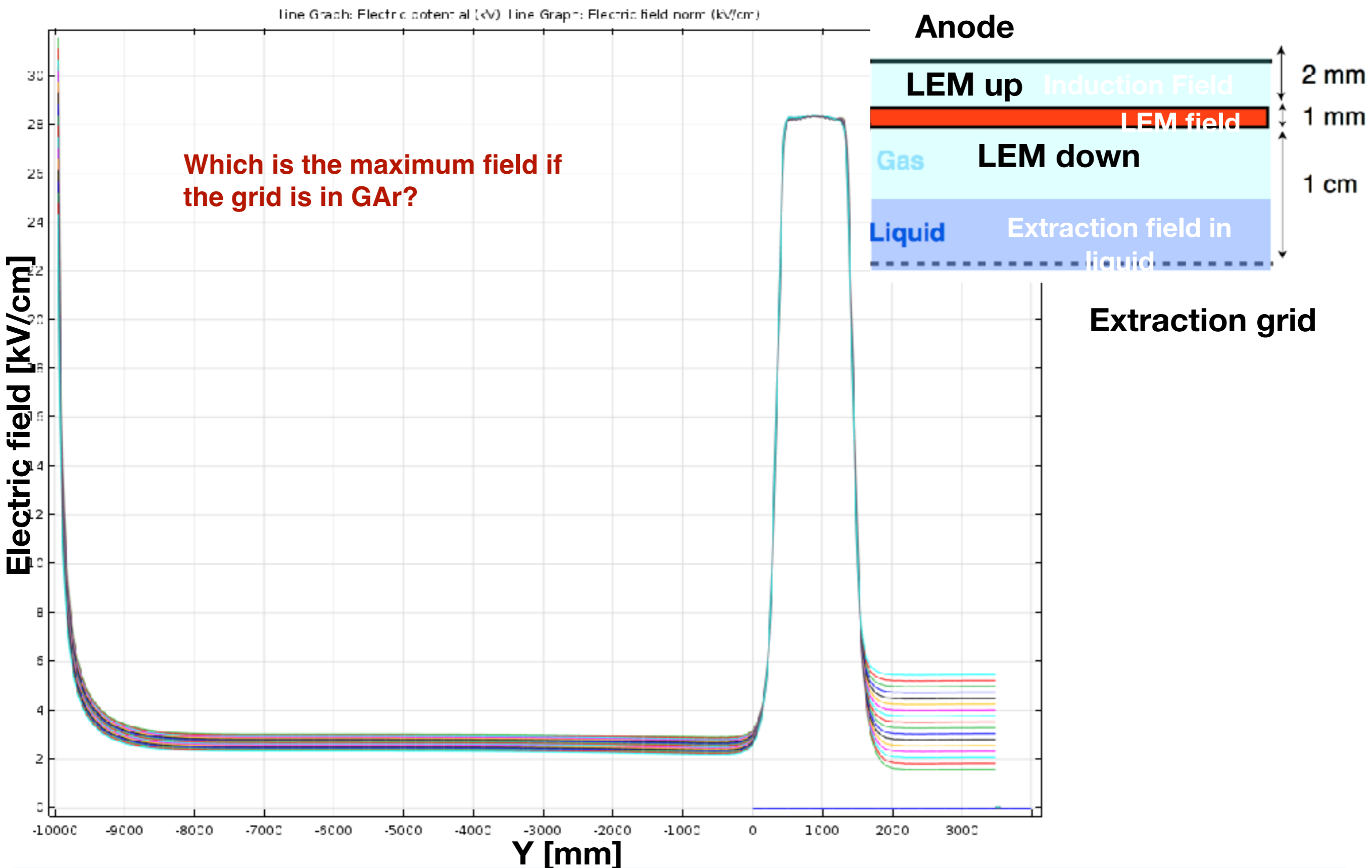

2) LAr level and pressure variations

3. No obvious correlation between trips and short-time variations of the level, as soon as the grid is immersed.

Extraction grid and Level (29.06)

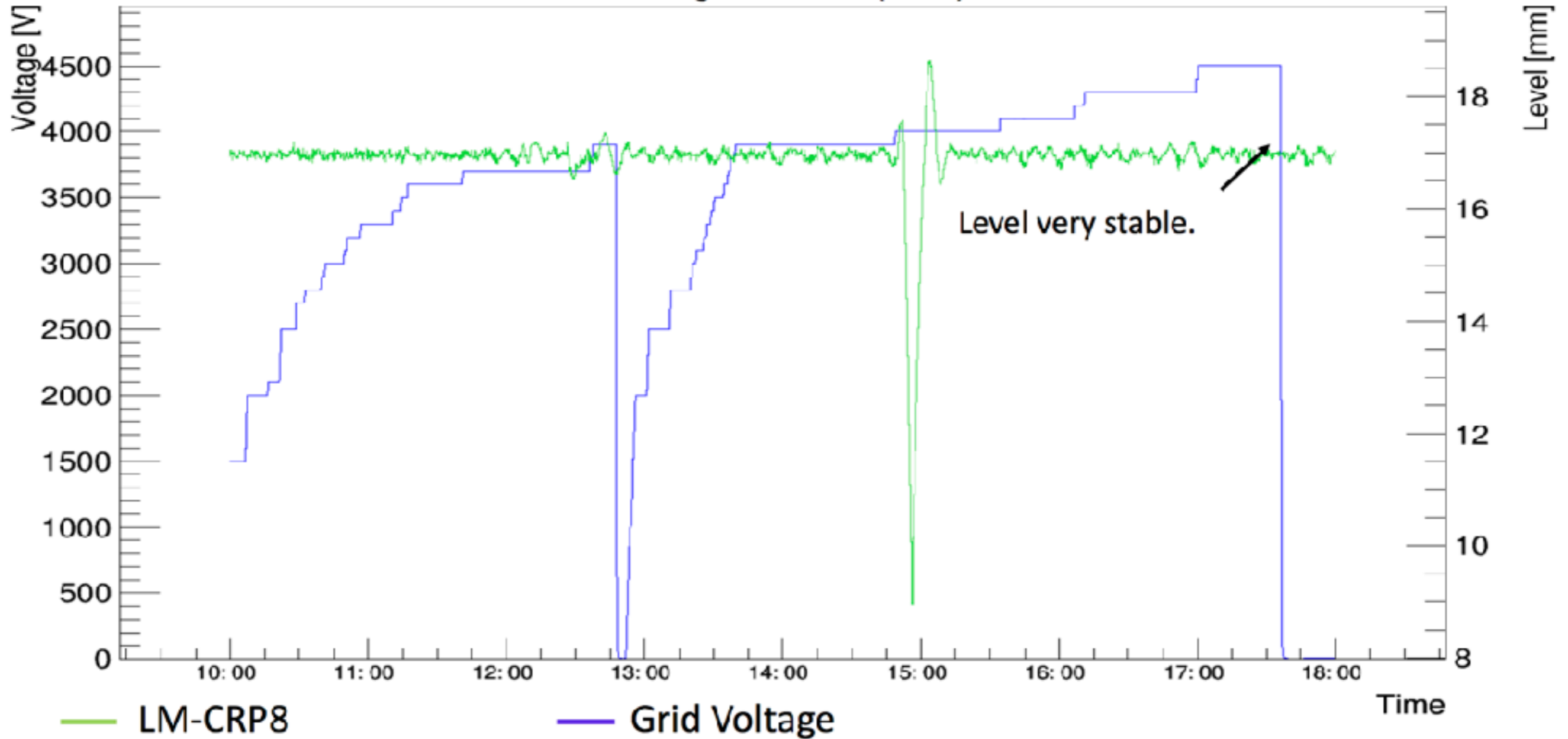

3) Grid-field cage

Laura Manenti
measurement

Tilt CRP-DC: use distance FFS to extr. grid
6 measurements corresponding to FR4 pillars
- Measurement A -

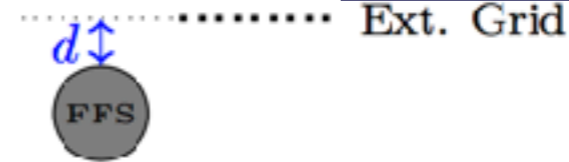
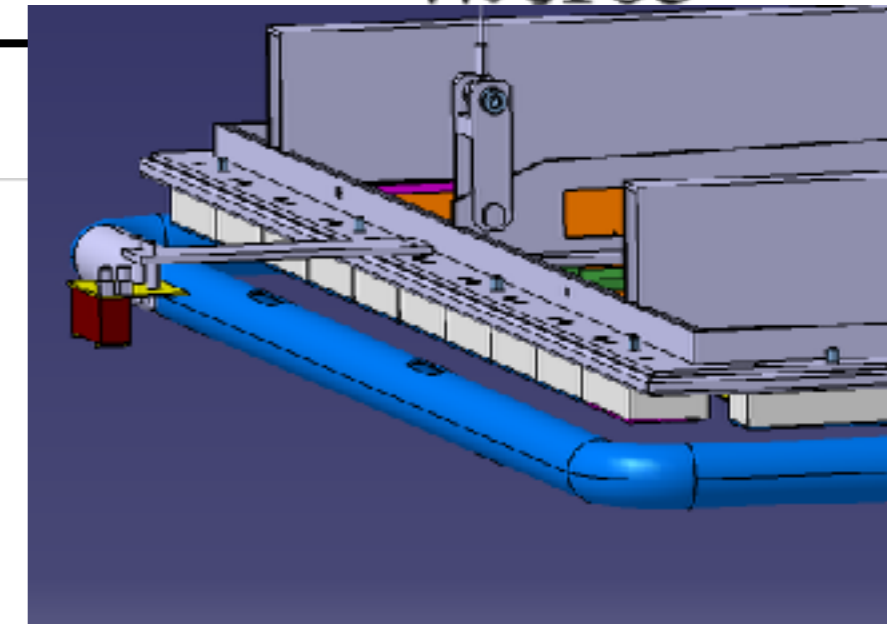
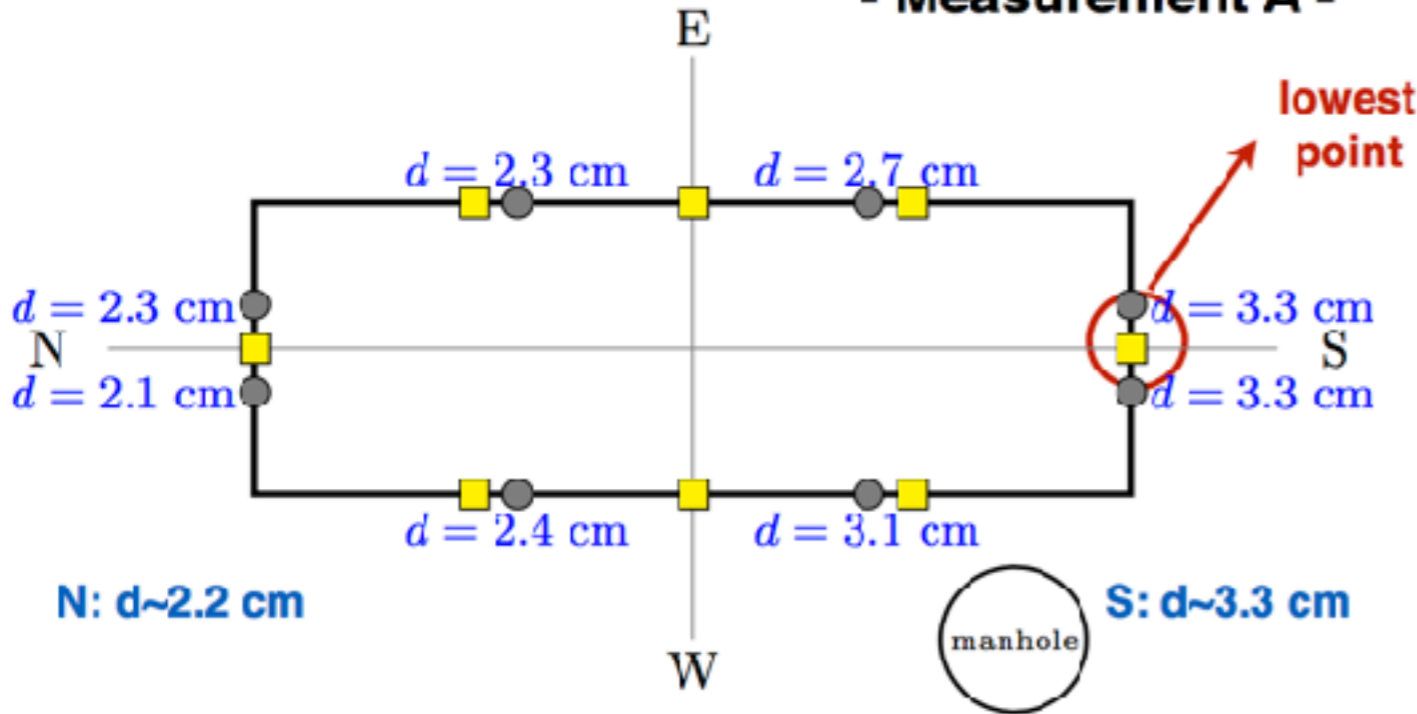

Considering tilt N-S axis only.
Tilt on E-W axis negligible.

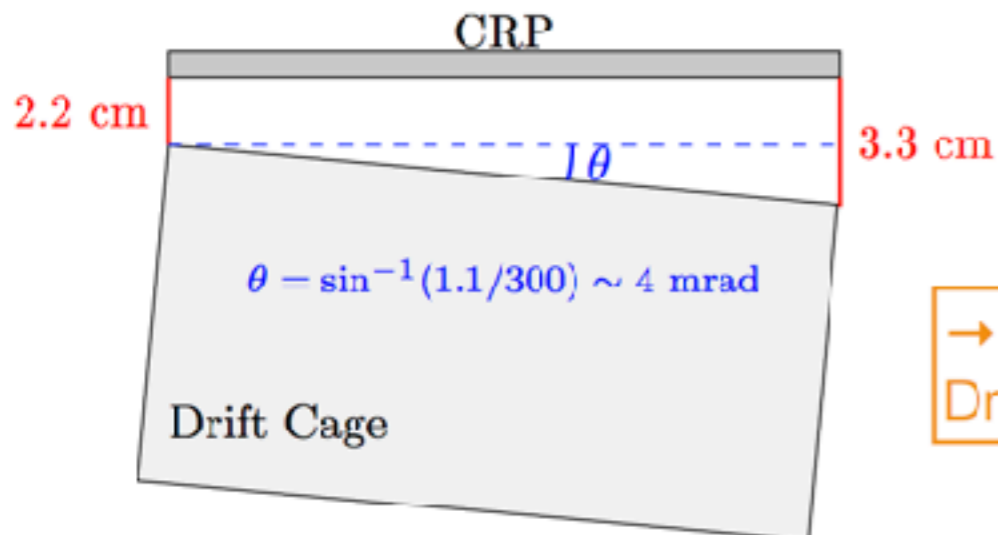

→ Now CRP is aligned with the liquid
Drift cage and CRP have a relative tilt of 4 mrad

3) Grid-field cage

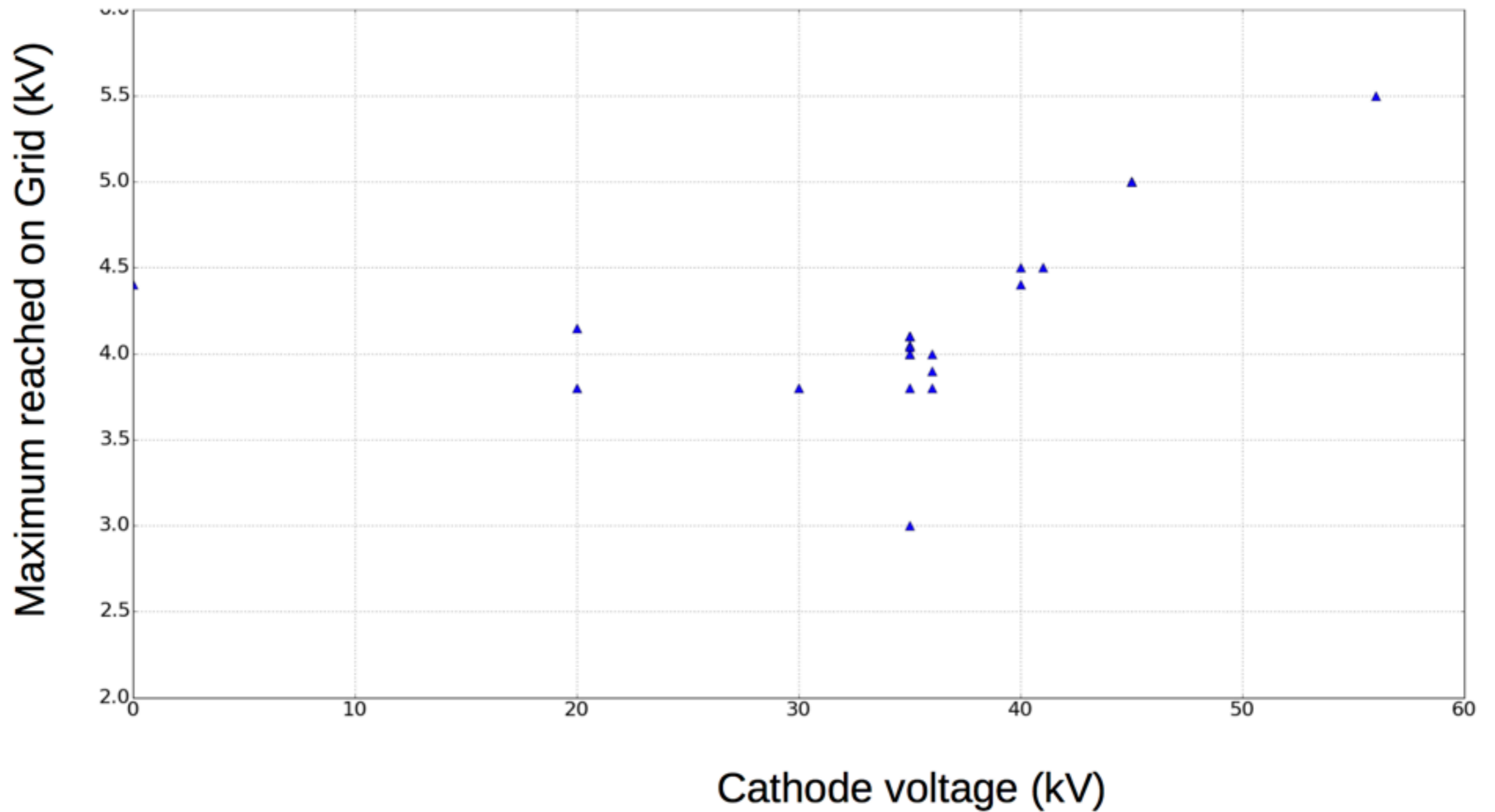

3) Grid-field cage

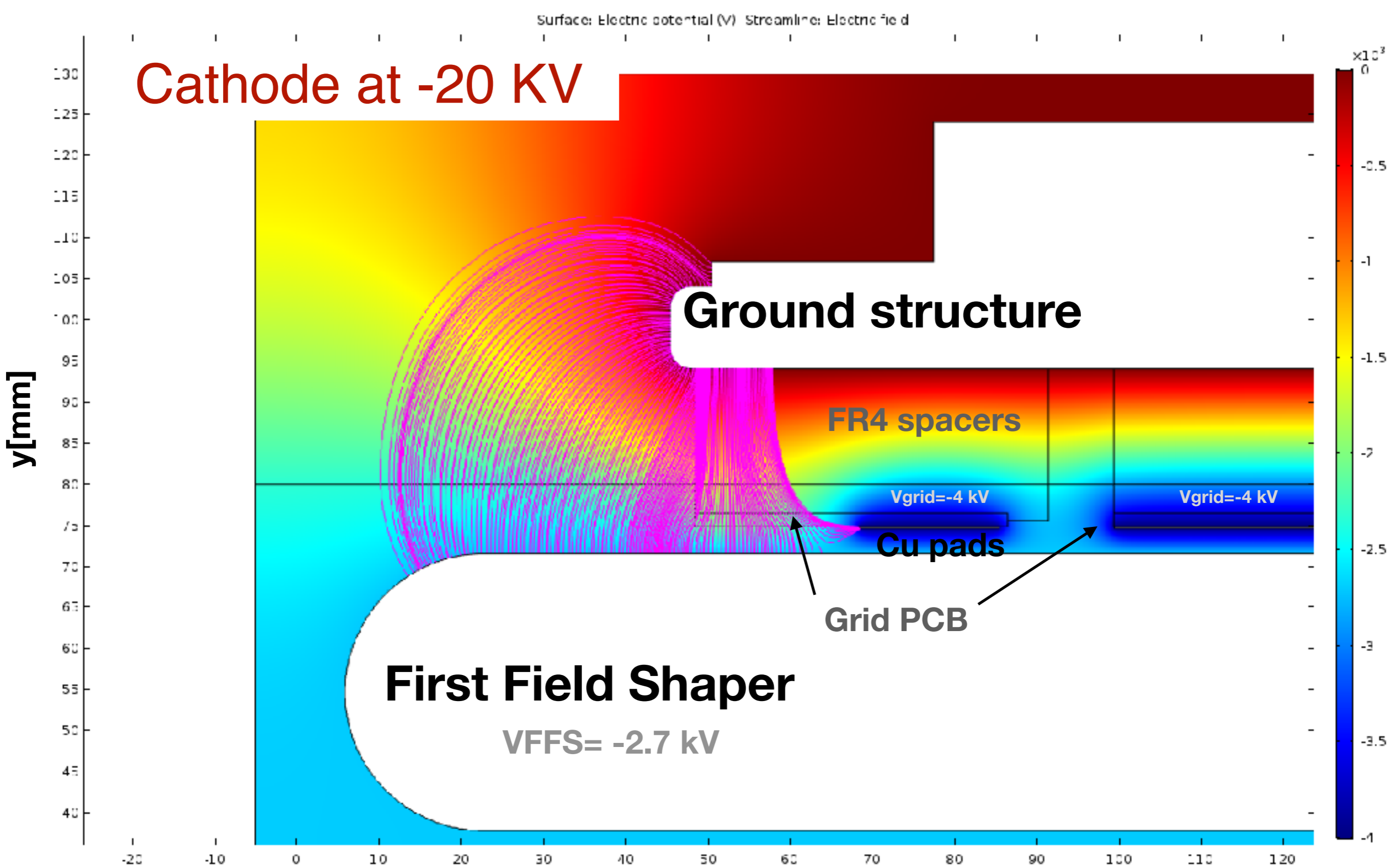

3) Grid-field cage

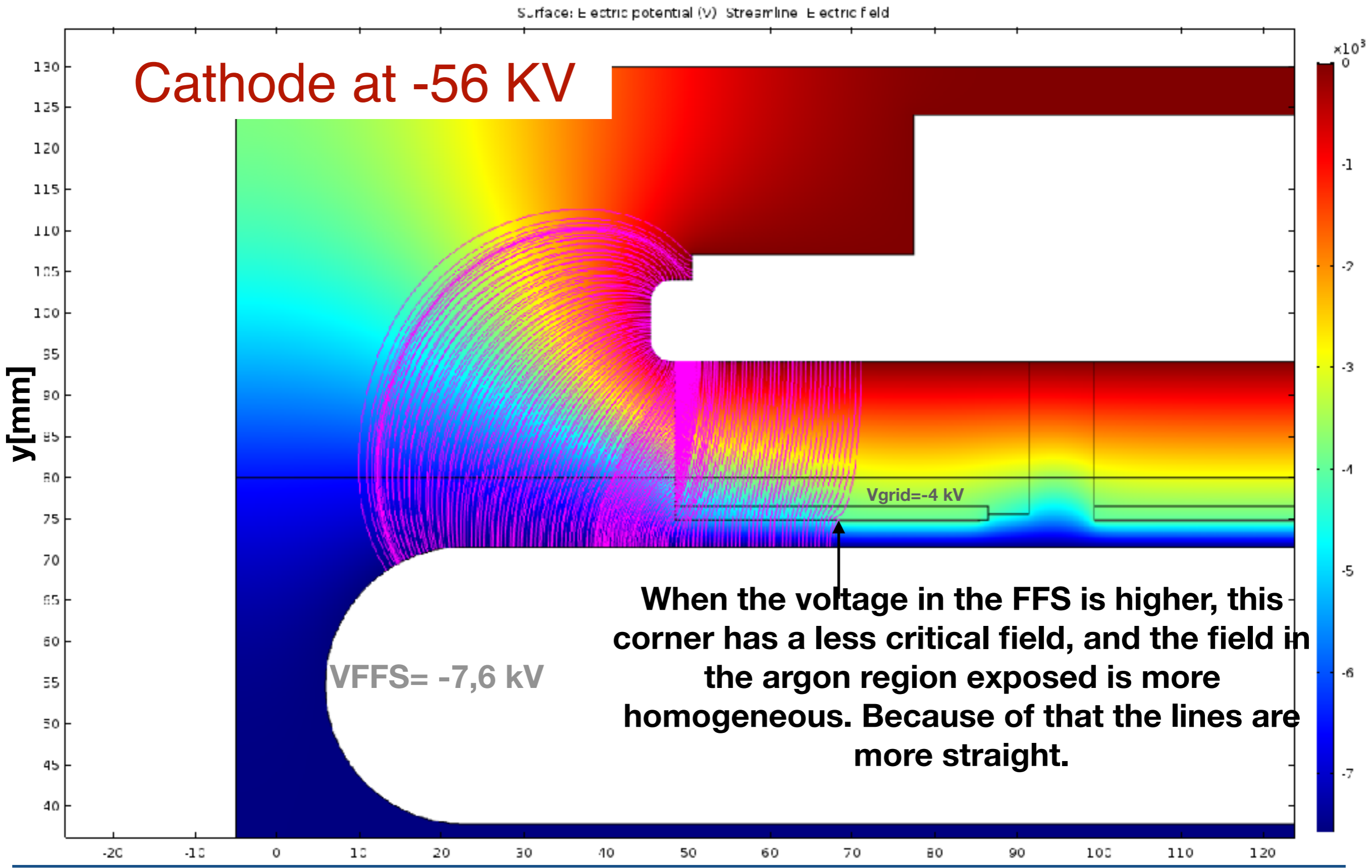

3) Grid-field cage

Possible evidence of contact between the field cage and the grid

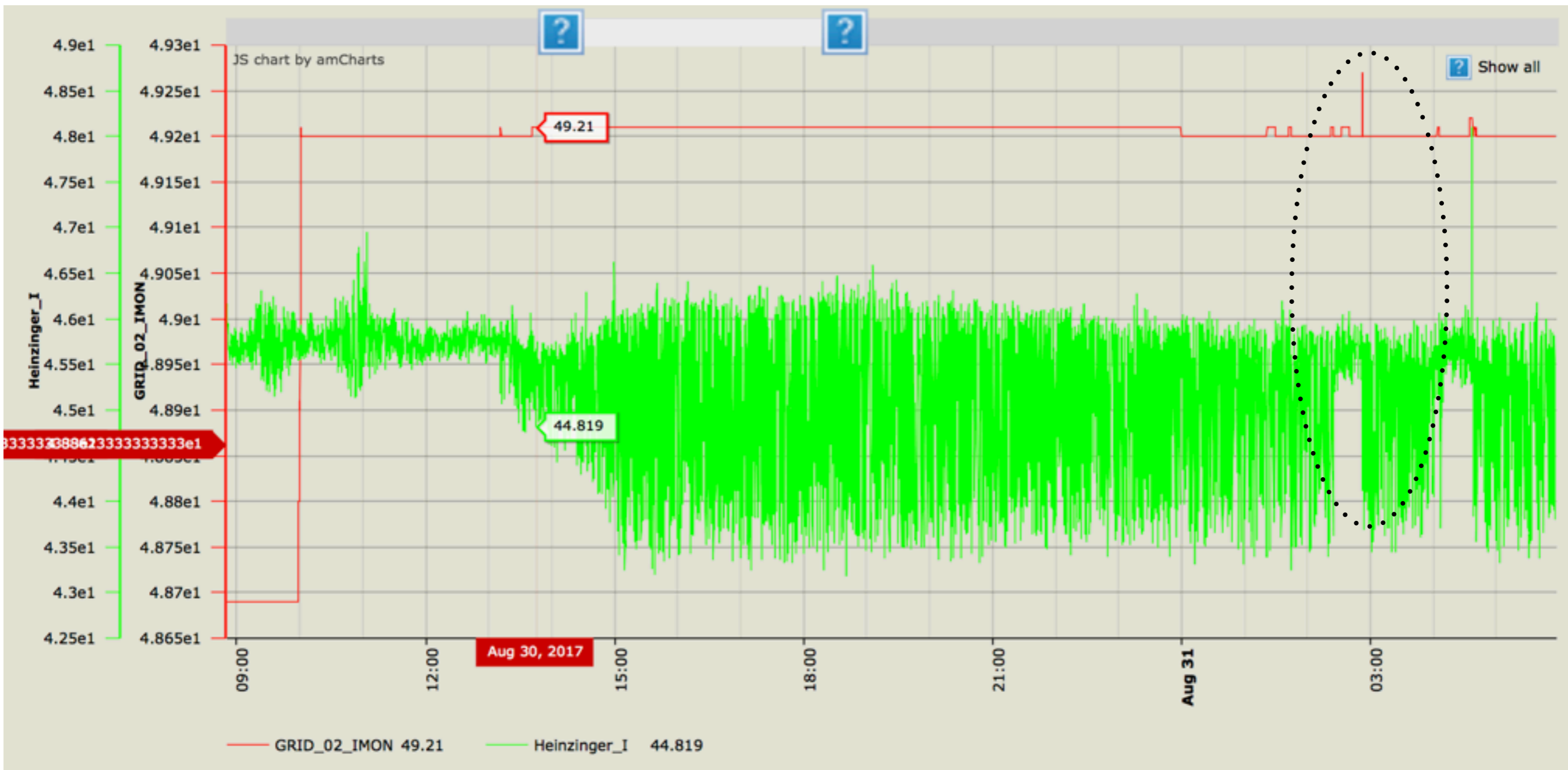

3) Grid-field cage

The cathode tripped

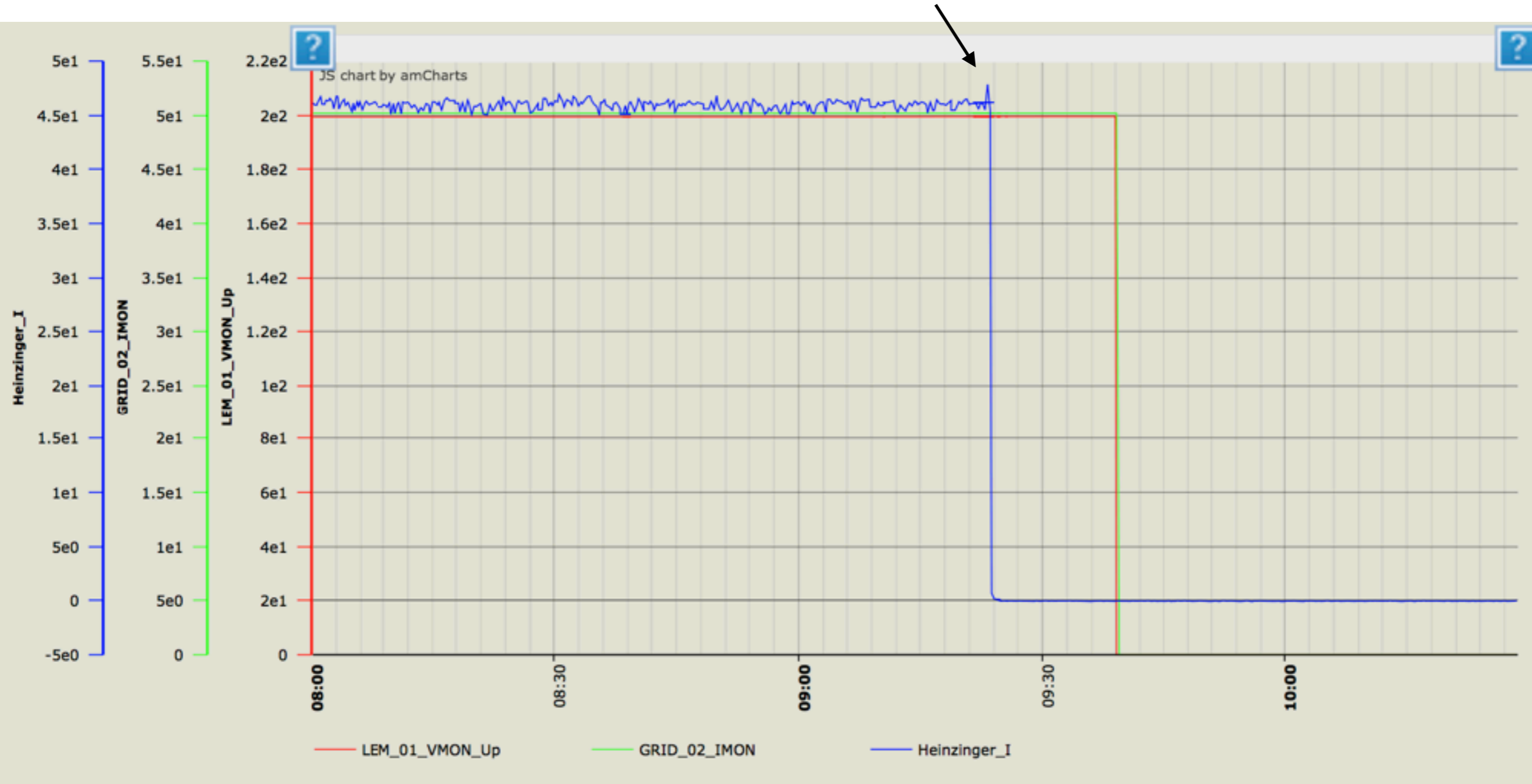

On **September 8th**, we raised the level 2 mm. Then, we ramp up the voltage on the grid leaving the LEMs at ground and we were not able to ramp up the grid above 2 kV and this was inducing a trip in 11 out of 12 LEMs down. To identify the issue we followed this steps:

1) We measure the resistance between each of the grid connections to ground, to see if there was any problem and we measure open loop as expected.

2) We verify that both grid connections, the one in the north and in the south, were connected.

3) We measured the capacitance between the grid and the ground, having all the LEMs connected to ground. In both flanges we measured 4,6 nF.

4) We also inspected visually the connectors of the grid to see if there was some rest of discharges

5) Then, we changed the grid connection to the other flange and we start ramping up the voltages. The grid tripped at the same voltage ,2kV, but this time LEM 4 did not tripped and

LEM 3 up and down tripped. All the other LEM down tripped. However, when we pulsed the grid north connection the behaviour on LEM 3 and 4 was opposite. Because of that, we thought that probably there are broken wires in this region and when we powered the LEMs they are attracted by electromagnetic force and there is a short between LEM down and the grid. To be sure, we disconnected LEMs 3 and 4 and we ramp up again the voltages. The grid tripped at 2 kV again but this time did not induce any trip in any of the LEMs down.

This region, is the one in the north, where the first field shaper and the CRP are closer.

4) Evidence of contact between the grid and the LEMs

On **September 13th**, we raised the level 2 mm more. Then, we ramp up the voltages and we were not able to ramp up the grid above 1 kV.

- 1) We tripped first LEM 2 up and then the grid at 1000V. We repeat the test 3 times recording movies with and without the LEDs ON.
- 2) We disconnect LEM 2 and we reconnect LEMs 3 and 4. The grid tripped at the same voltage LEM 3 and 4 as yesterday.
- 3) Finally, we left all the LEMs OFF which means they are at 0V floating, and we powered the grid. As you can see from the plot there is a clear connection between the grid and the LEM4 down, as you power the grid and immediately you see almost the same voltage on LEM down.

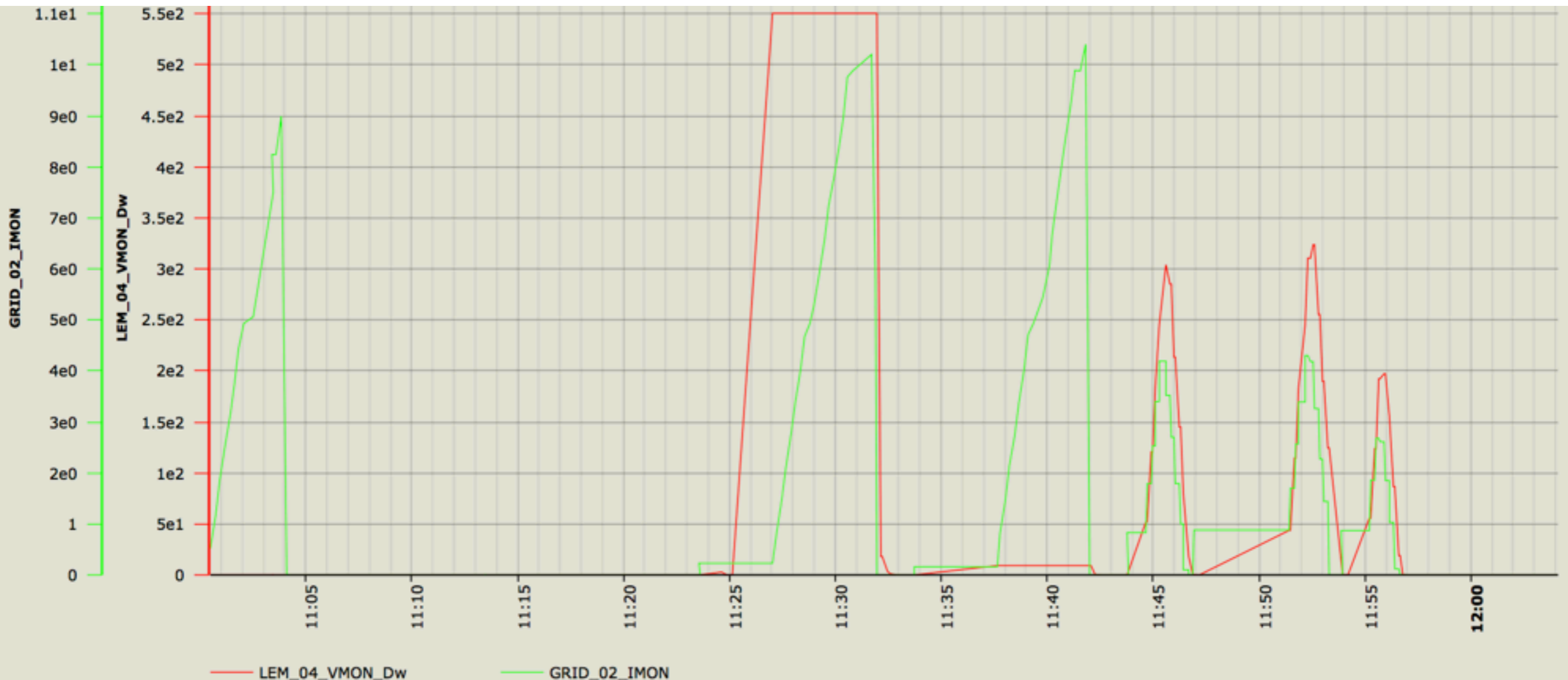

4) We measured the **capacitance between the LEMs and the grid** after filling the tank with an additional 2 mm of LAr. The capacitances were measured through the LEM/grid connections on the SCFTs. They were measured through a standard BNC cable, connected to the grid on the north flange and a custom LEMO connector with a simple copper wire, connected to the LEM HV connections.

The average capacitance between LEM down and the grid increased from 214 pF to 242 pF after the first filling and then to 318 pF after the second filling. The capacitance measurement between LEM 4 and the grid gave a negative measurement, characteristic of an electrical short between the two.

Indeed, measuring the resistance, a value of 16.6 Ohm was obtained, confirming that one of the grid wires is touching LEM 4. The capacitance between the grid and LEM 4 up was measured to be 8.61 nF which is the capacitance between LEM up and LEM down, which is in agreement the previous values.

5) Pulsing of the grid

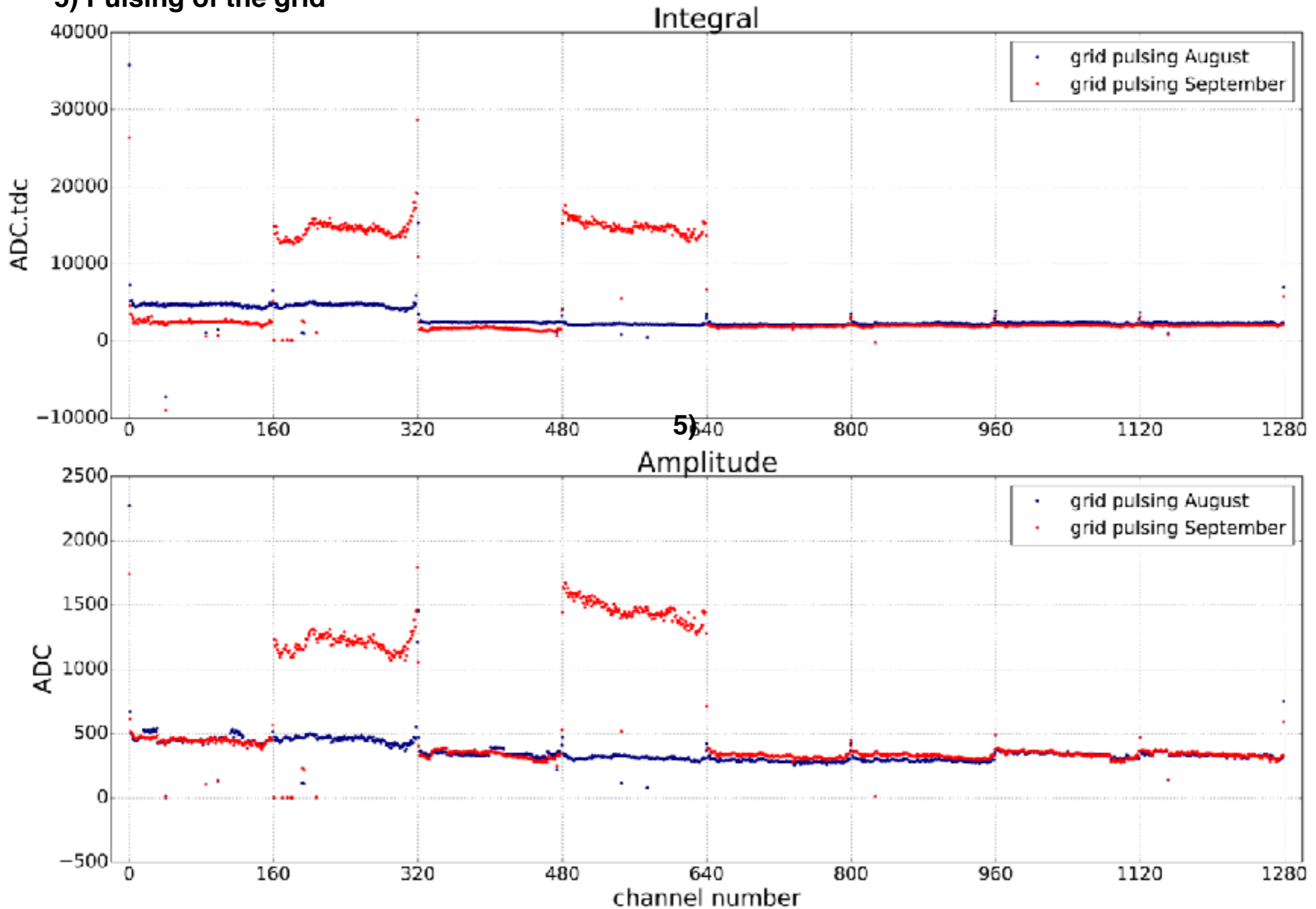

5) Grid HV connection

Test performed on July 6th with FFS terminated to ground, grid ON and LEMs ON at 0 V.

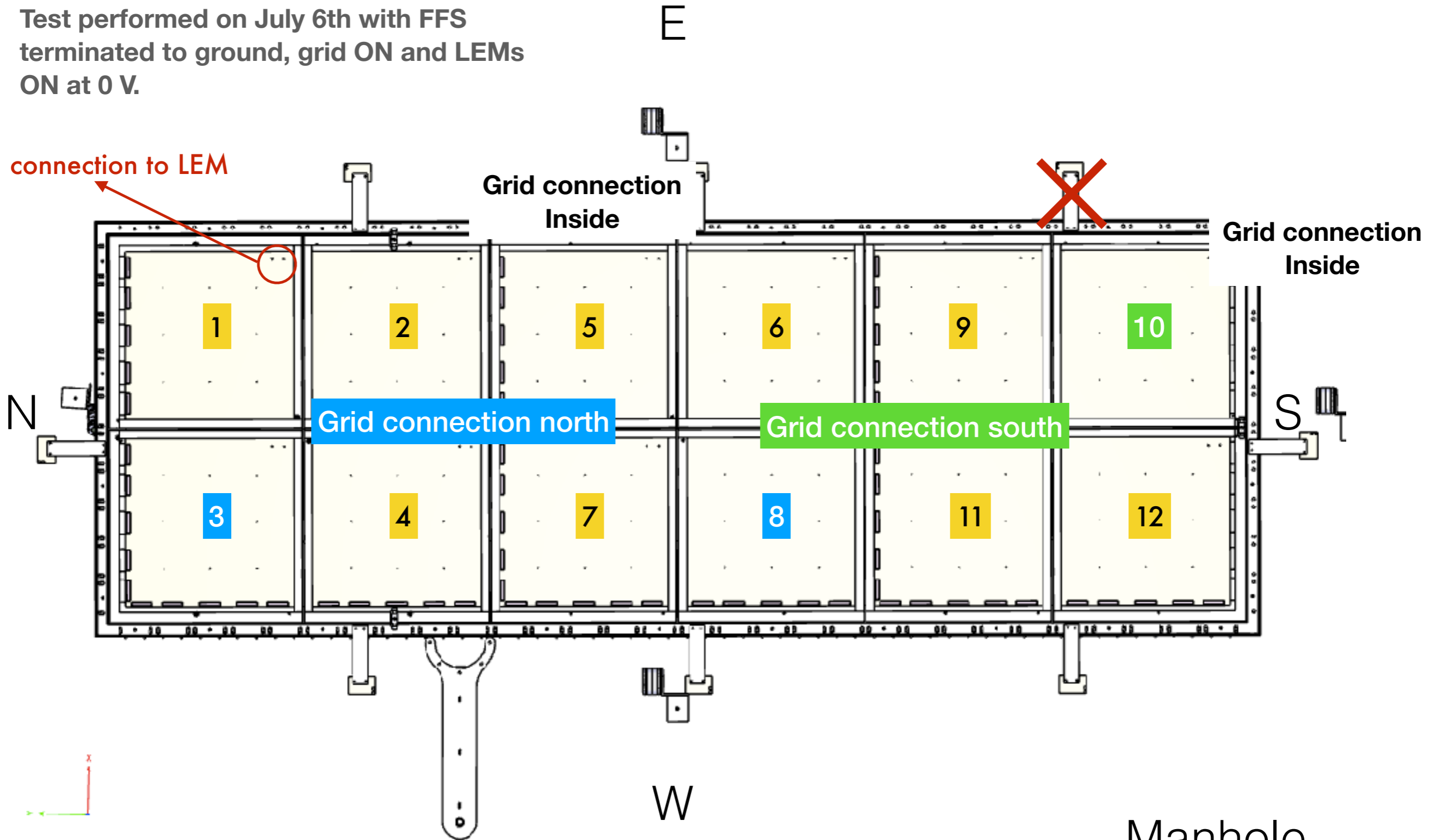

The grid tripped ramping up to 4,8kV Tripped between 3,8 and 4kV corner Manhole



- We prepared a similar configuration to the HV contact made inside the 3x1x1 to test it in an independent setup.
- Since September 15th, the setup for the grid connection HV test for the 3x1x1 and 6x6x6 grid connections was finalized (see <http://lbnodemo.ethz.ch:2500/3x1x1/405>).
The connections have been placed between rods hanging from the top flange of the large dewar in Bldg. 182. After closing the dewar, it has been evacuated using a primary pump and a turbo and a vacuum of $3e-5$ mbar was reached. Subsequently, the dewar was filled with Argon, which was purified using a cartridge. For this procedure a smaller dewar was filled with LAr and used as a bubbler such that the pressure in the main dewar always remained close to atmospheric. The two grid connections were thus tested in an atmosphere of pure GAr at cold, with the bottom of the dewar having been filled with LAr.

5) Grid HV connection

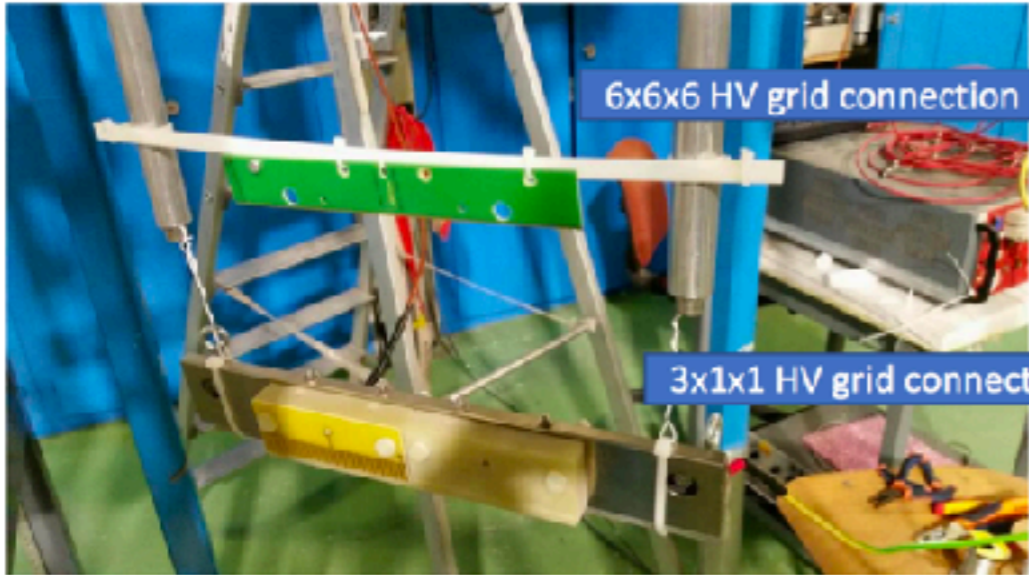

6x6x6 HV grid connection

3x1x1 HV grid connection

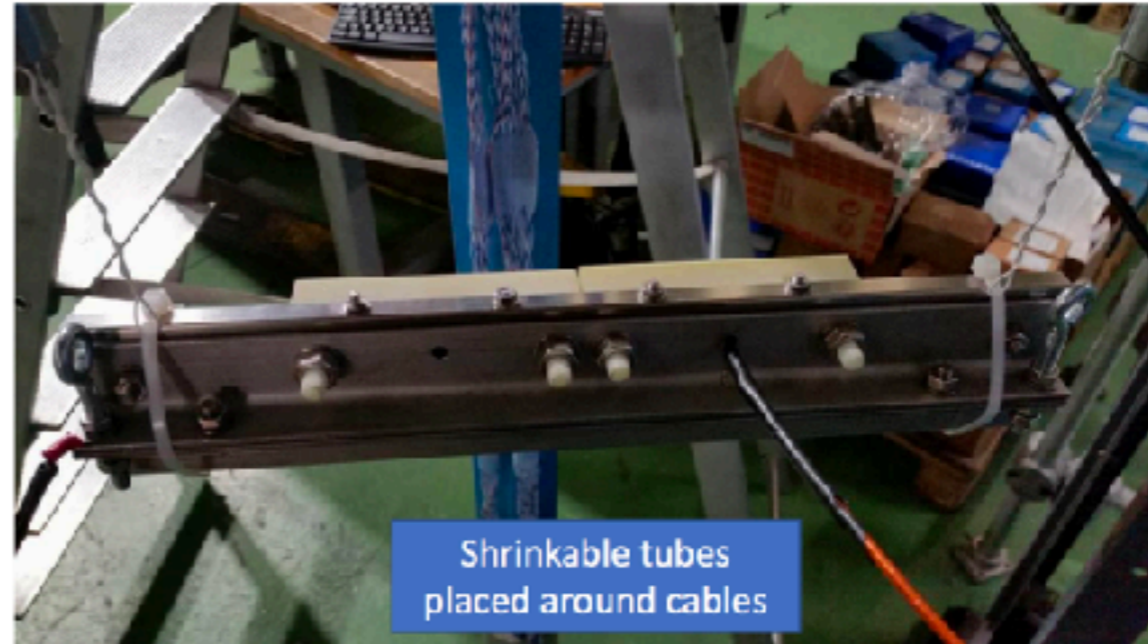

Shrinkable tubes placed around cables

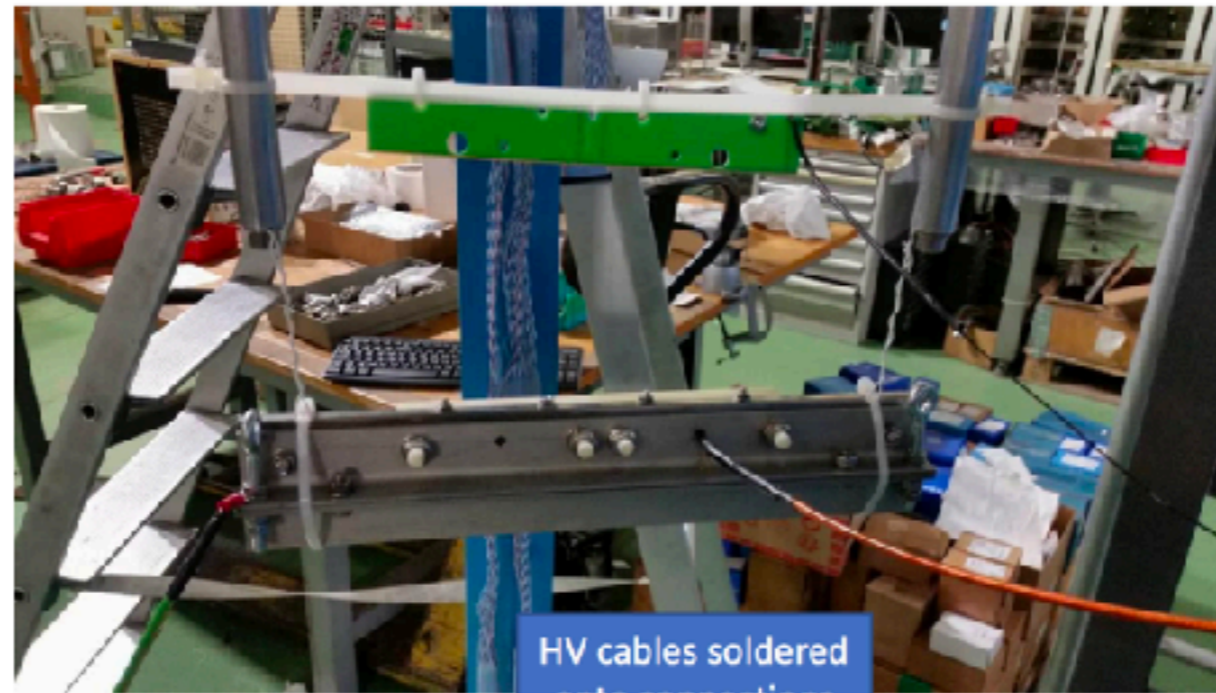
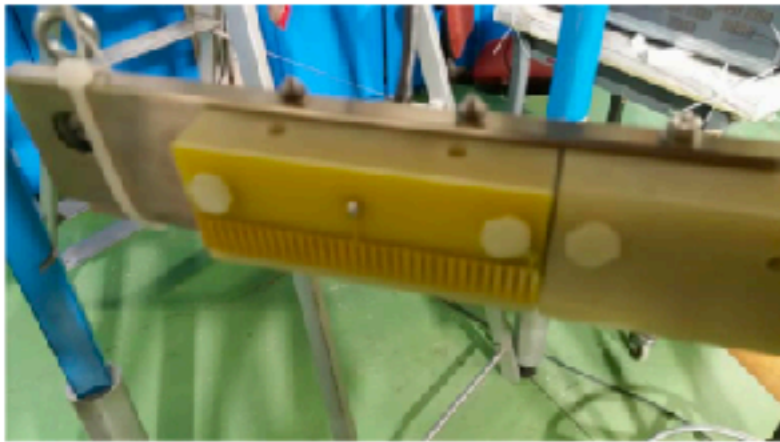

HV cables soldered onto connections

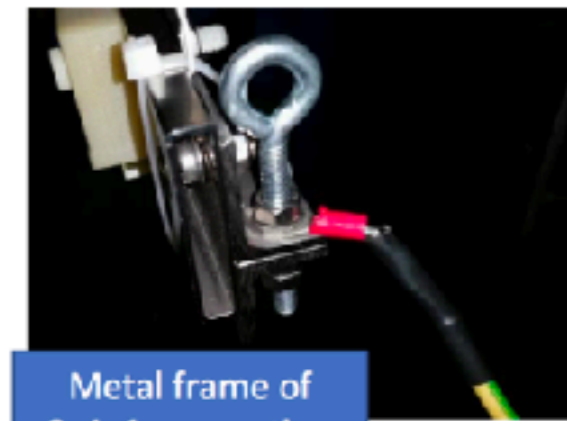

Metal frame of 3x1x1 connection grounded

5) Grid HV connection



3L HV power supply

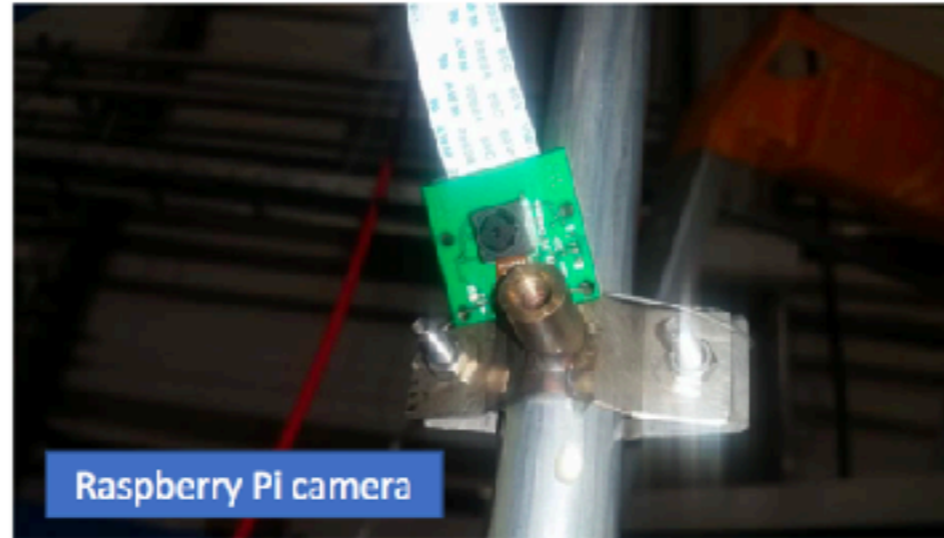

Raspberry Pi camera

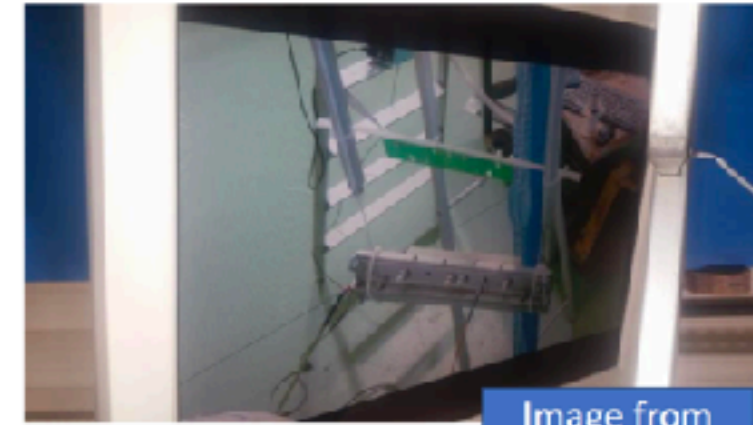
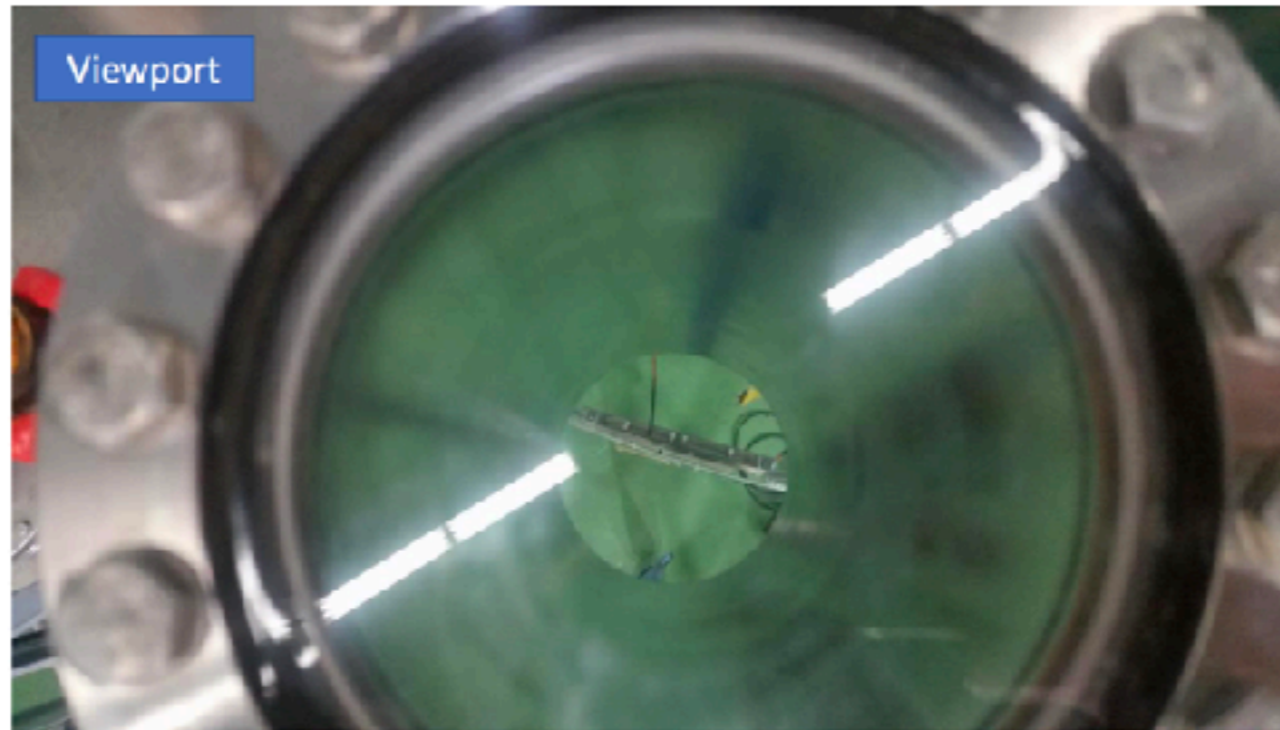

Image from camera



3L HV feedthrough



Viewport



Dewar

The **3x1x1 grid connection** was found to have small discharges for voltages above 4.5 kV with the frequency of the discharges increasing with the voltage. At 5 kV, it starts to discharge continuously until it trips. A video of the camera feed of the discharges can be found here: <https://www.dropbox.com/s/ieassgopf41oxdw/Grid311HVconnectionTrip.mp4?dl=0>

We tried to change the trip time, allowing for example a certain current over a second, and this help us to go up to 5 kV, and even once up to 6 kV. However, if you keep the voltage stable over some time, typically one hour, we were having trips since 5 kV. The situation was similar to what we observe inside the 3x1x1 where the grid voltage was stable up to 5 kV. As you can see from the movie it seems discharges inside the cable, in the part that traverses the frame to arrive to the PCB where the wires are soldered.

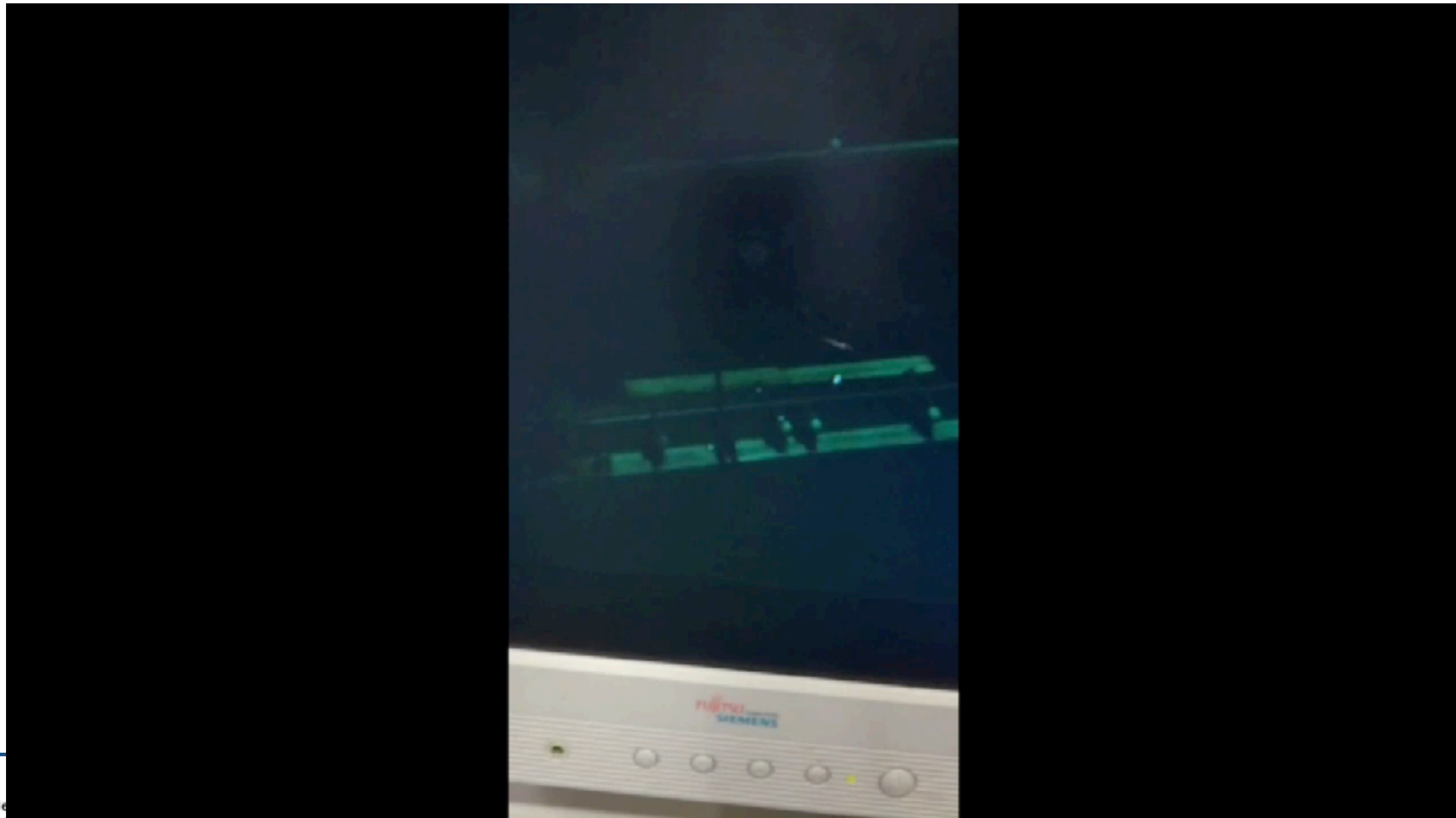

Possible indications of space charge effect or electric field distortions

- 3x1x1 field maps does by Silvestro including only space charge effect. Simulations ongoing to see the effect
- We plan to update them including the field cage.

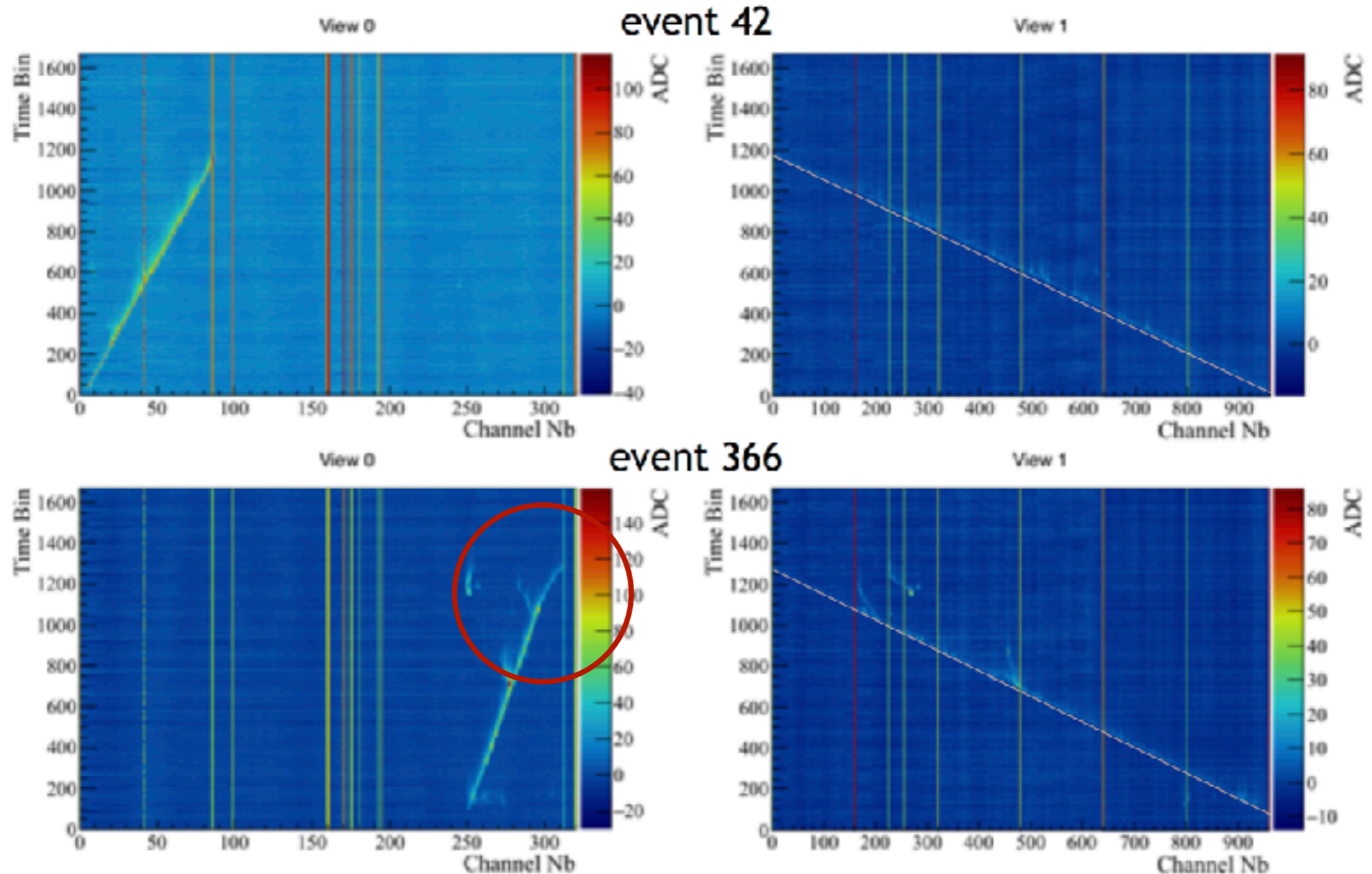

run 840 has ~6h of good quality data
 subdivide in 4 samples of ~1h30m each of 8375 triggers

sample #	time [s]	Nb 3D tracks	Nb track selected
1	5207	8869	687
2	5443	8793	719
3	5312	8653	614
4	5289	8259	571

1	2	5	6	9	10
3	4	7	8	11	12

LEM 1,3,10, 12 at lower field

- LEM 28kV/cm
- Extraction field in liquid ~1.9 kV/cm
- Drift 500V/cm
- PMT trigger

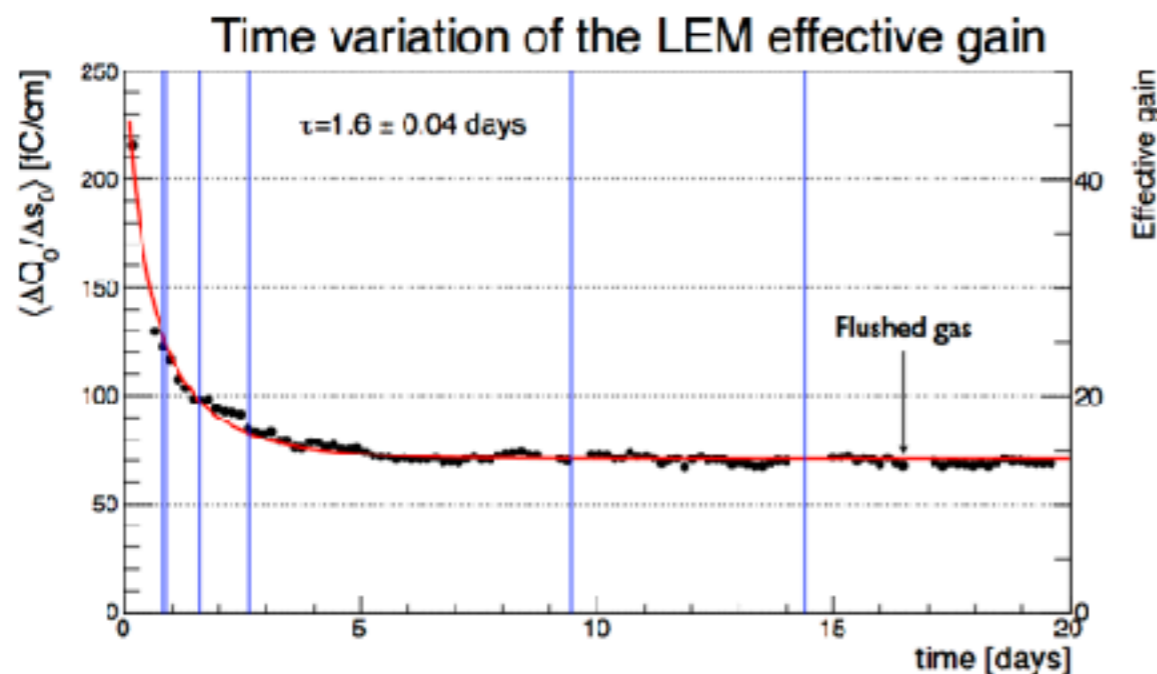

In the 3L, a time evolution of the LEM gain was measured with $\tau = 1.6$ days (at 30 kV/cm)

C. Cantini *et al.*, JINST 10 (2015) no.03, P03017

C. Cantini *et al.*, JINST 9 (2014) P03017

Using MPV fit

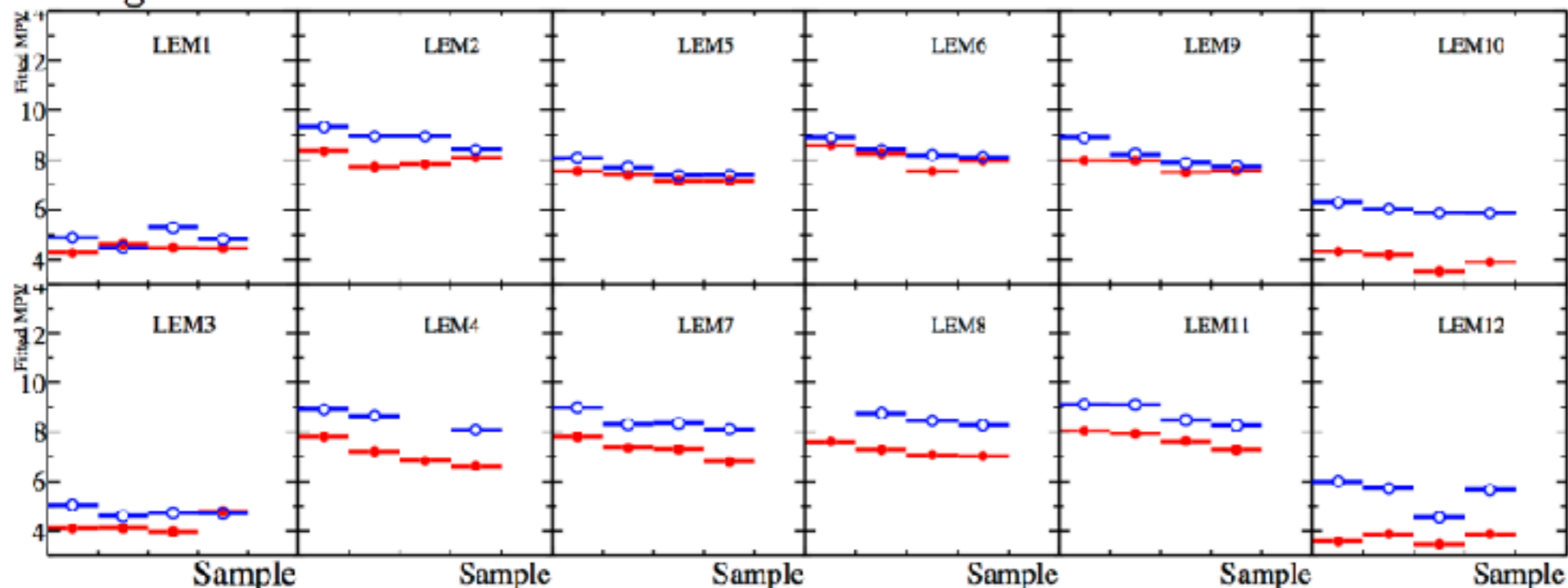

View 0
View 1

Using truncated mean

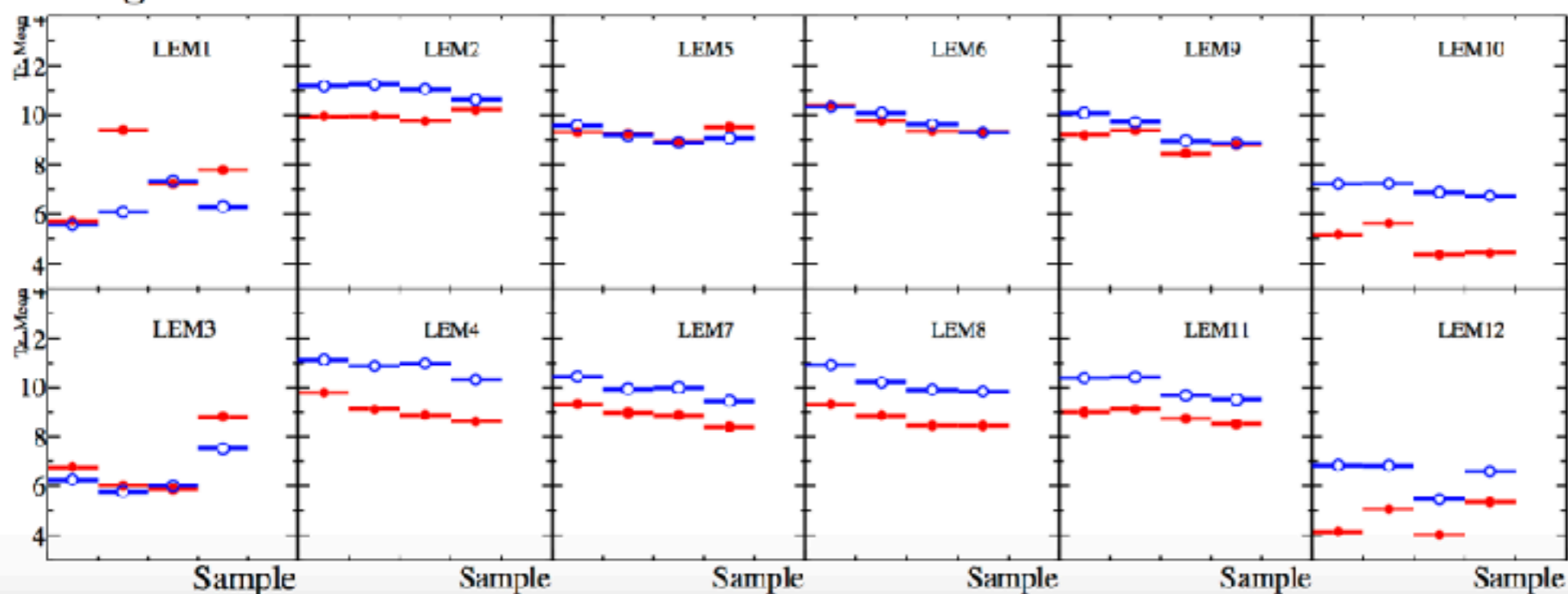

A decrease of measured dQ/ds as a function of time can be seen

Preliminary results!
Further studies ongoing

Back-up

- Liquid argon pump for recirculation
- Cosmic ray taggers (CRTs)
- Photomultipliers(PMTs)
- Very high voltage (VHV) system
- Charge readout plane (CRP)
- Slow control system

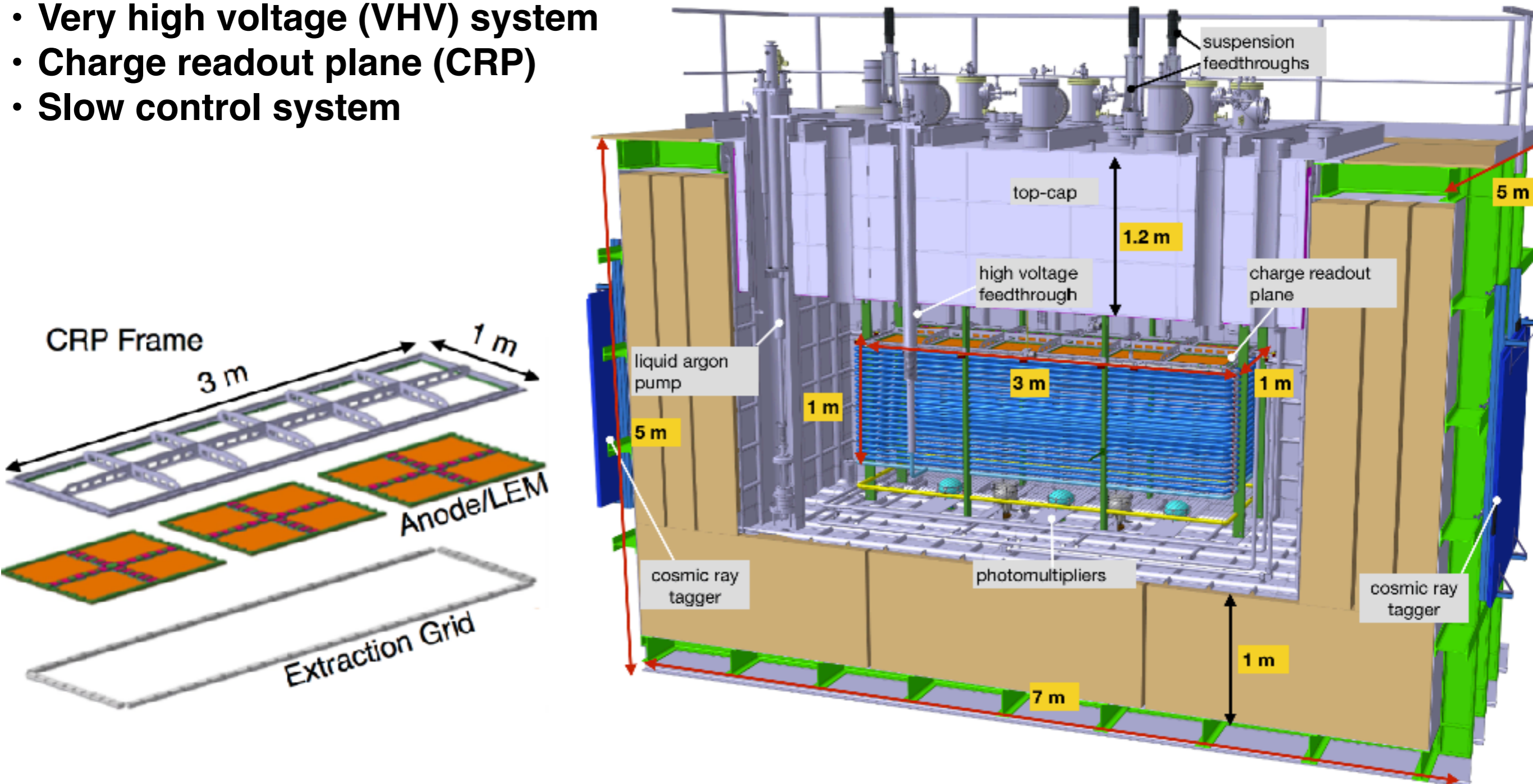

- **High voltage system:**
 - Performance limited by the sparks of the extraction grid before the operation voltage (-6.5 kV).
 - The boards of CAEN HV power supply were re-calibrated a couple of times during operations and one needed to be repaired.
- **Very high voltage system:**
 - Monitoring of the current and voltage, control of ramp up and ramp down speed successfully done through RS232 analog port. However, we identified an offset of 1 kV from the value displayed on the Heinzinger interface and the one read it on the slow control system.
 - Some instabilities of the current observed and two trips along the whole 2 months of performance.
- **Cryogenic system performance:**
 - Heat load higher than expected value
 - Instabilities of the level due to the pressure regulation of the condenser. The cryogenic system was regulated according to one of the CRP level meters value to avoid this issue.
- **Slow control system:**
 - Some communication problem between CAEN power supply and the slow control system
 - Two stops of the slow control system along the two months of performance
- **Charge readout system:**
 - Good performance since the system was installed on December. However, since the end of August the DAQ program crashed suddenly and we realised that was due to problems with the SSD disk of the White rabbit machine. After repairing the disk the system is completely
- **Analysis of data ongoing:**
 - Possible indications of space charge effect or distortions of the electric field.
 - Possible indications of ion accumulations that need further investigations.

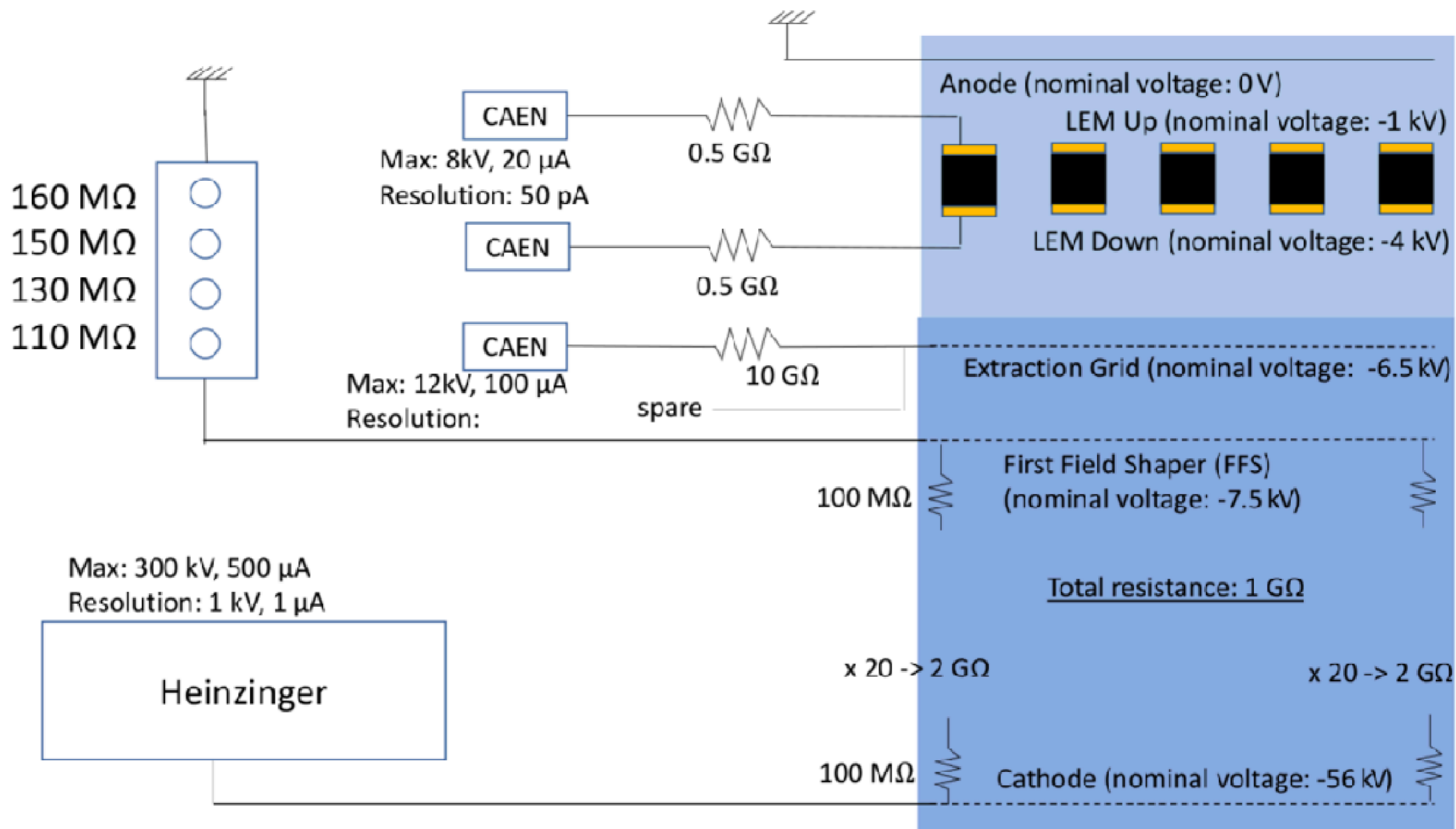

Summary of runs during HV tests

Details of the runs

Date	Cathode Voltage (kV)	FFS voltage (kV)	Grid Voltage (kV)	LEM voltage (kV)		Drift Field (kV/cm)	Extraction in Liquid (kV/cm)	Amplification (kV/cm)	Induction Field (kV/cm)	Liquid above Grid (mm)	Comments
				Down	Up						
Cathode off, other elements on											
7.07	0	0	3.8	2.6	0.1	0	1.18	25	0.5	95	trip while ramping LEMs
7.07	0	0	4.1	3 ⁽¹⁾	0.3	0	1.08	27	1.5	95	grid only tripped, after 2h
7.07	0	0	4	3 ⁽¹⁾	0.3	0	0.98	27	1.5	95	stable for 1h then shut down (no trip)
17.07 – 18.07	0	0	4.4	3 ⁽⁴⁾	0.2	0	1.38	28	1	95	stable 14h then grid trips. LEM 2h later
LEM and cathode off											
25.07	0	0	4.9	0	0	0	4.82	0	0	95	grid and LEMs tripped
25.07	0	0	5.25	0.5	0	0	4.57	5	0	95	grid and LEMs tripped
Everything on											
9.07	35	4.7	4.1	3.2 ⁽²⁾	0.3	350	0.98	29	1.5	95	Grid tripped then LEMs (not while ramping)
9.07	35	4.7	4.1	3.1 ⁽³⁾	0.3	350	0.98	28	1.5	95	Grid only tripped after 1 minute
9.07	35	4.7	4	3.2 ⁽²⁾	0.35	350	0.78	28.5	1.5	95	stable for 1h then shut down (no trip)
10.07	35	4.7	4.05	3.1 ⁽³⁾	0.2	350	0.98	29	1	95	stable
11.07	35	4.7	4.05	3.2 ⁽²⁾	0.2	350	0.98	29	1	95	stable for 2h then grid trip then LEMs
12.07 – 16.07	similar runs with similar results										
19.07	56	7.6	5.5	3 ⁽⁴⁾	0.2	560	2.46	28	1	95	up to 5.5, tripped while ramping grid
20.07	56	7.6	5.3	3 ⁽⁴⁾	0.2	560	2.26	28	1	95	up to 5.3, stable for 50ms
25.07	40	5.4	3	3.1 ⁽⁴⁾	0.2	400	-0.1	29	1	95	grid then LEM tripped
25.07	40	5.4	4.2	3.1 ⁽⁴⁾	0.2	400	1.08	29	1	95	2h stable then grid trip
25.07	67	9	5	3.1 ⁽⁴⁾	0.3	670	1.97	28	1.5	95	stable 2h30
26.07 – 27.07	53	7.2	5	3.1 ⁽³⁾	0.3	530	1.97	28	1.5	95	stable for 8h. Grid trips, LEM 9 2h later

⁽¹⁾LEM 1, 3 and 10: 2.7 kV
LEM 12: 2.4 kV

⁽²⁾LEM 1, 3, 10 and 12: 2.7 kV

⁽³⁾LEM 1, 3, 10 and 12: 2.6 kV

⁽⁴⁾LEM 1, 3, 10 and 12: 2.5 kV

2) LAr level and pressure variations

12 → 13.07.2017

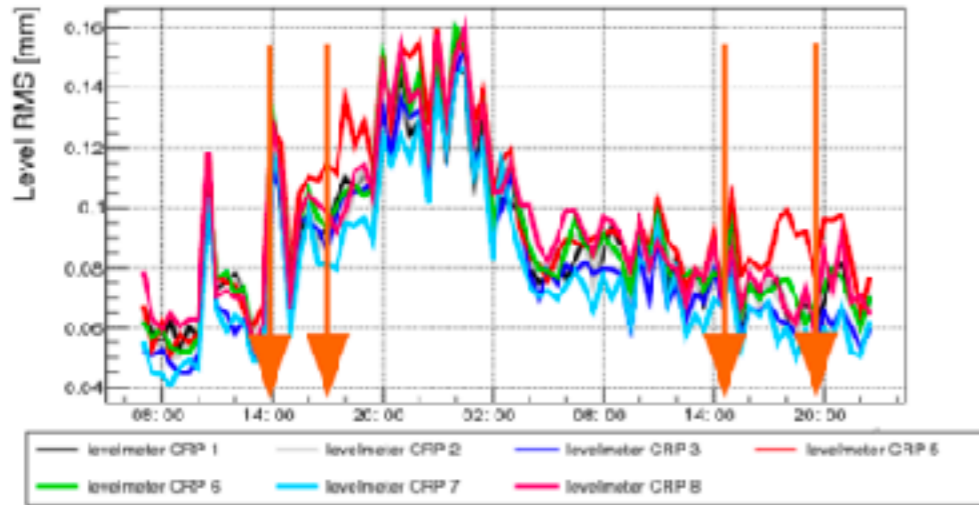

14 → 15.07.2017

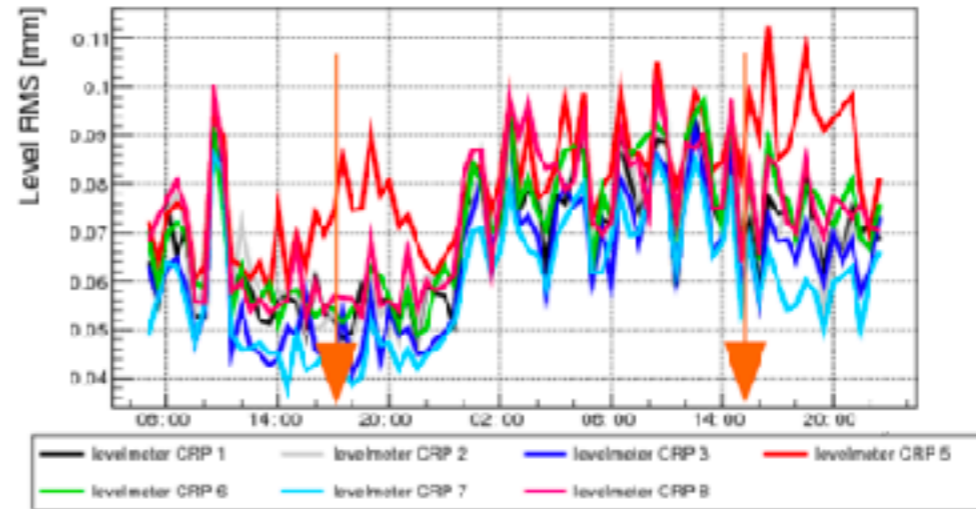

26 → 27.07.2017

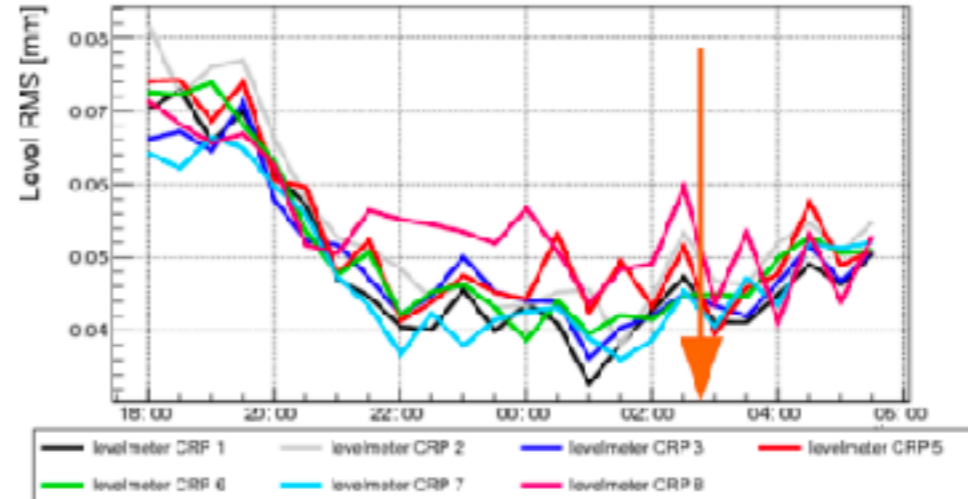

25.07.2017 particularly stable and yet trips

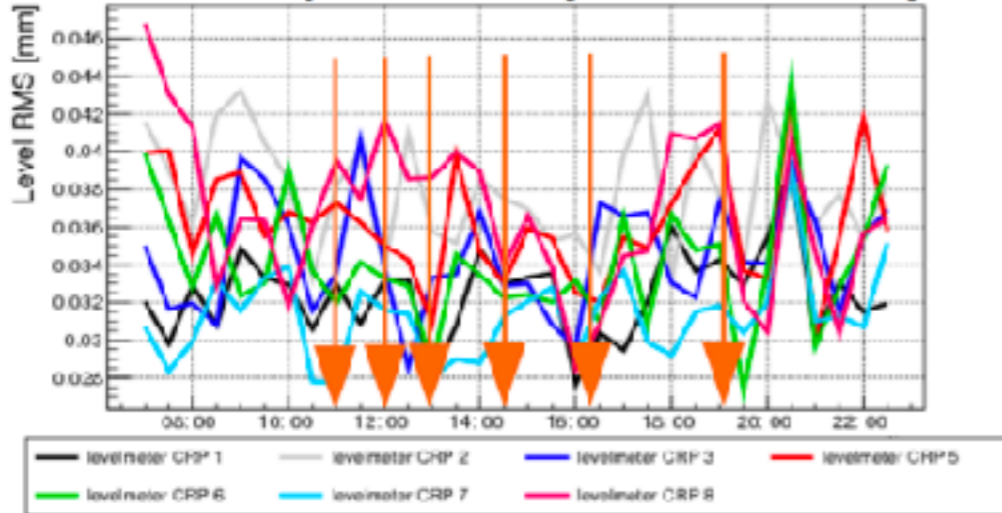

No obvious correlation, but study needs refining 31

2) LAr level and pressure variations

12 → 13.07.2017

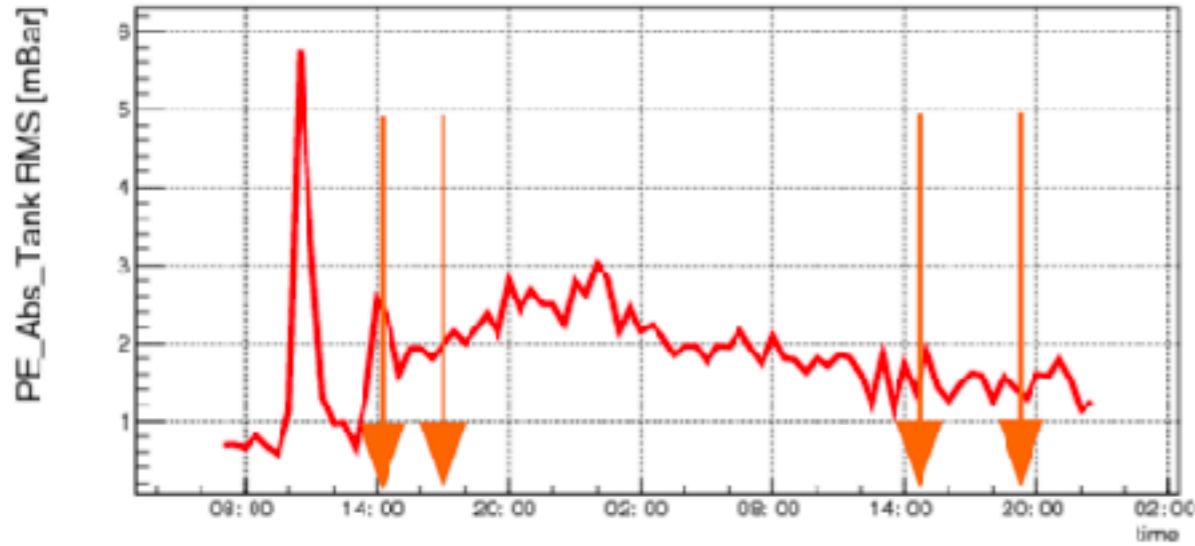

14 → 15.07.2017

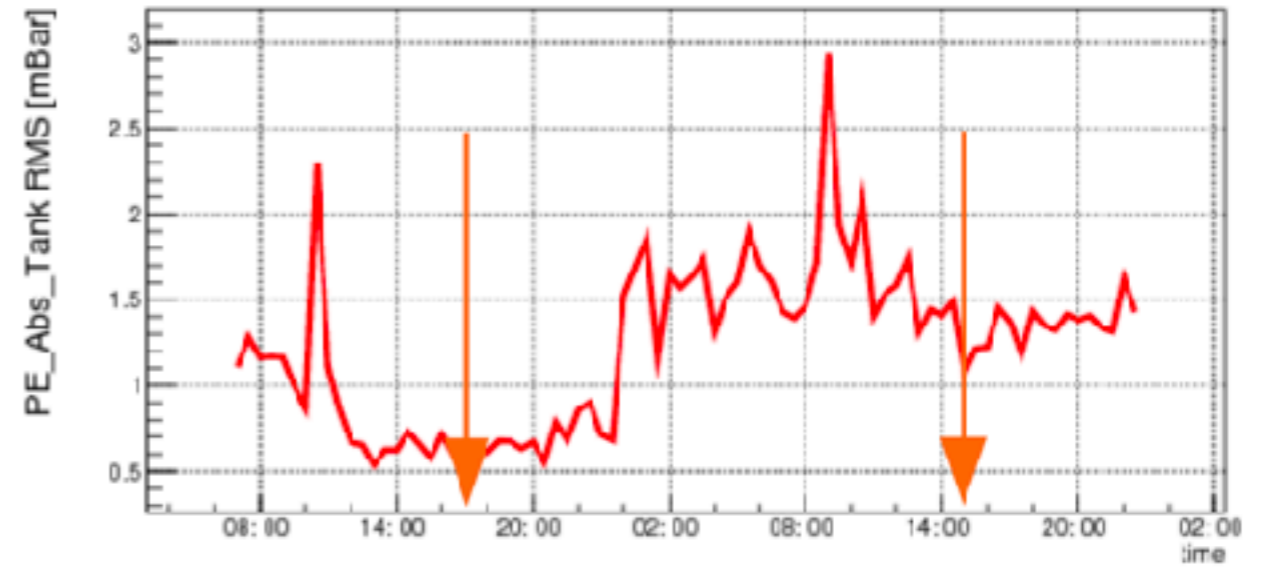

25.07.2017 particularly stable and yet trips

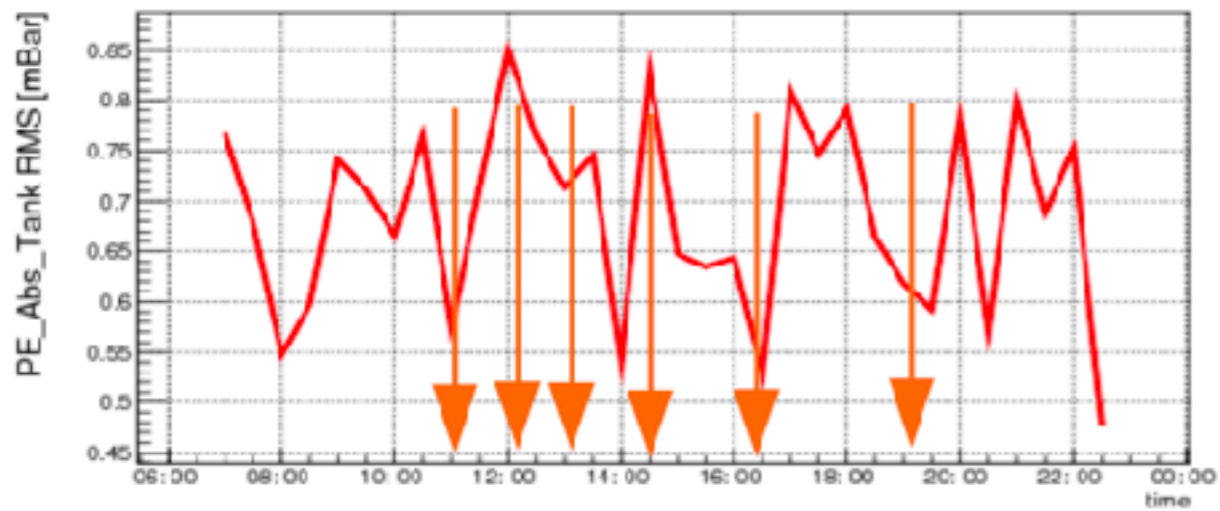

26 → 27.07.2017

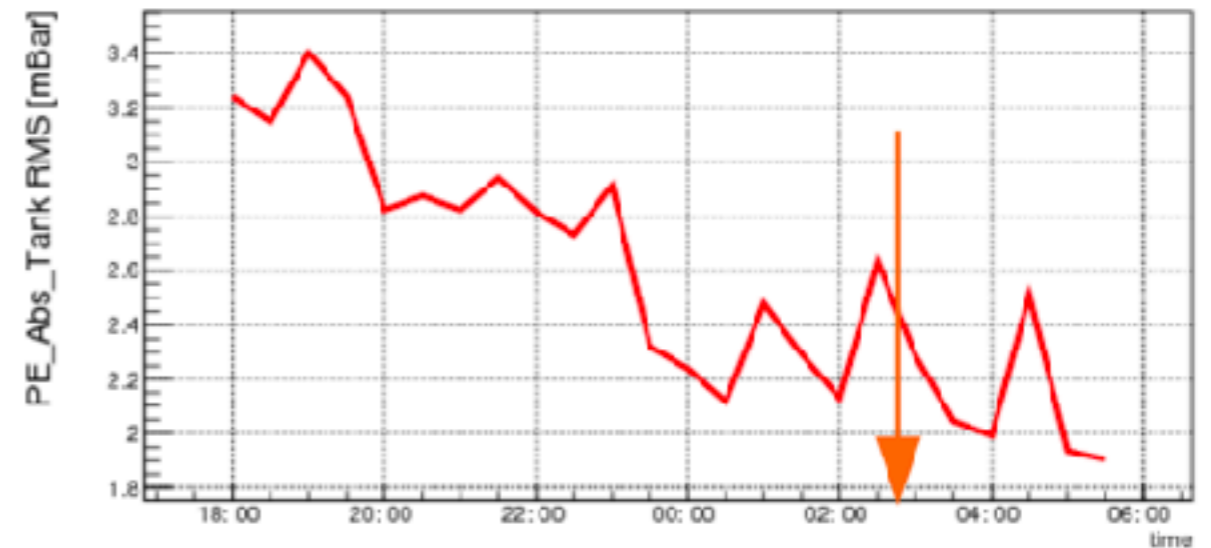

We identify liquid level variations due to instabilities in the cryogenic system

Level meter measurement

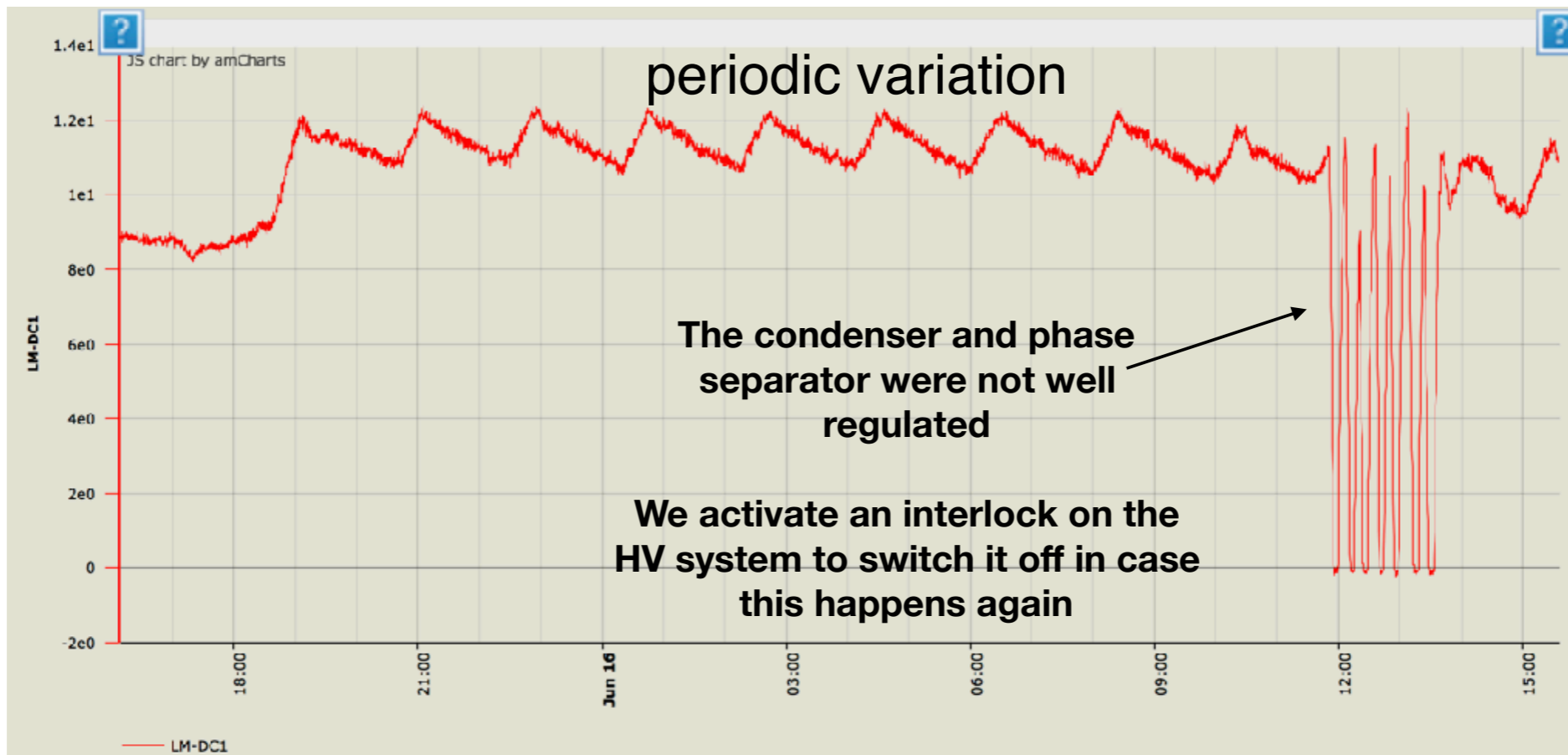

Camera's movies provide very useful information!

Liquid level during issues with the cryogenic system regulation

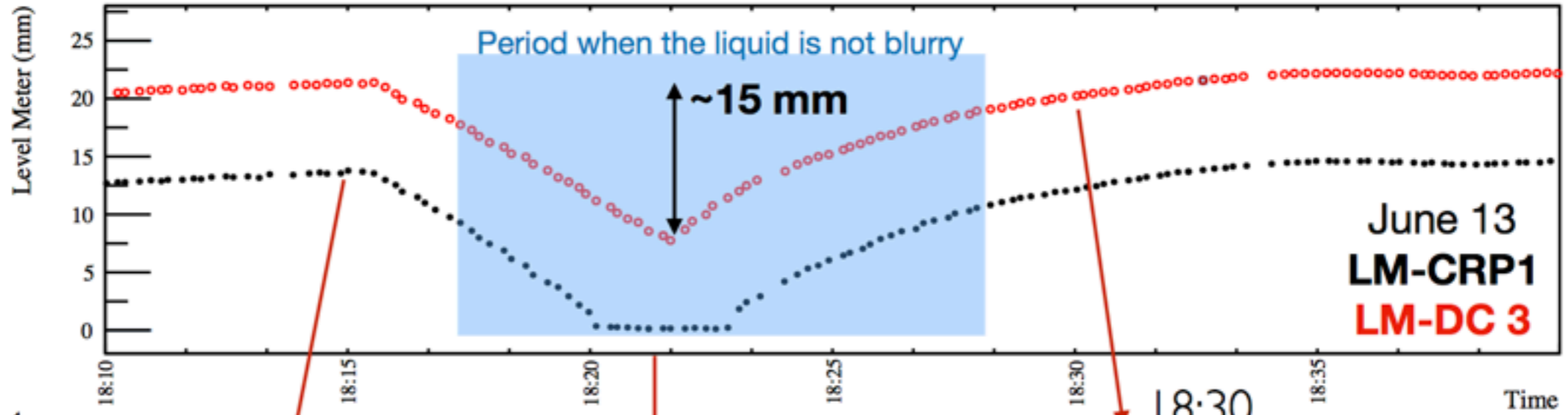

June 13
LM-CRP1
LM-DC 3

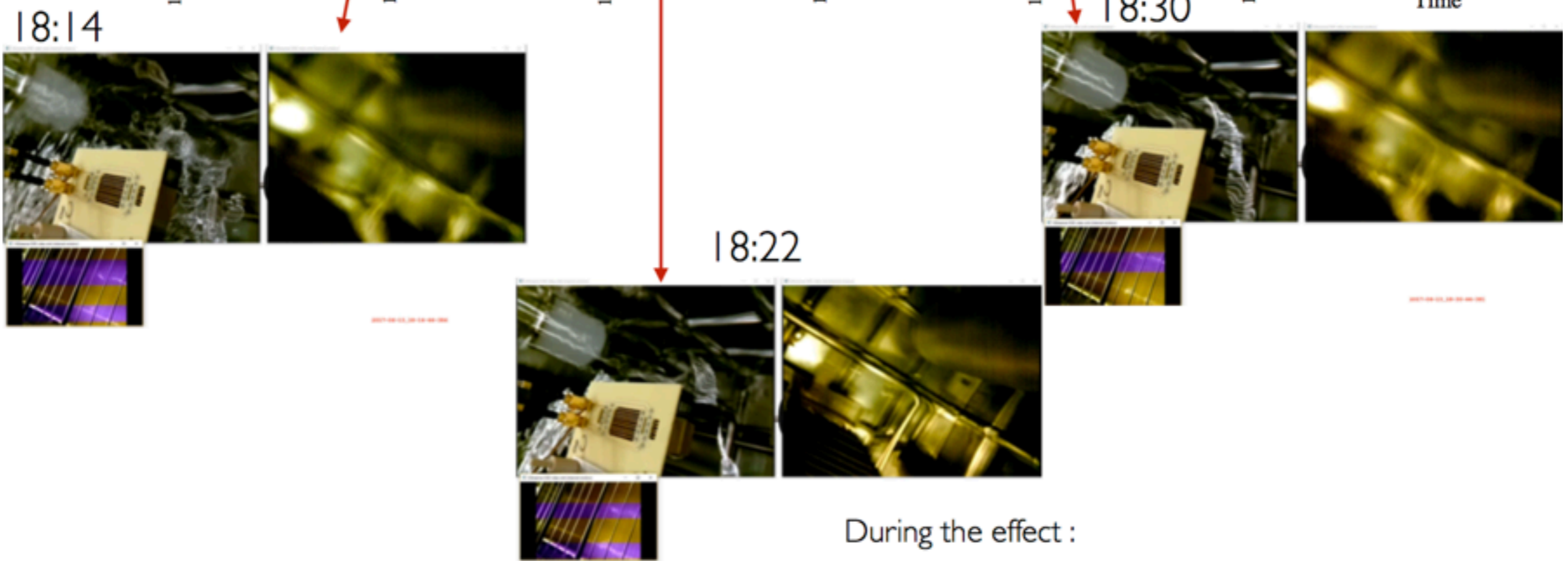

During the effect :
• HVFT seems to be moving → optical effect

- **May 2017:** CAEN Boards suddenly stopped working, Cal.Ext error on all the channels simultaneously. They have to be calibrated and firmware upgraded.
- **May 26th 2017:** CAEN Boards A1580HDN were recalibrated by CAEN team at CERN and the latest firmware uploaded. The problem was a bug in the previous version of the firmware which was leading to a reset of the memory where the calibration tables are stored. This bug is now fixed, we will be notified of any newest firmware's releases as soon as they come. During the calibration procedure they discovered one faulty channel on one board: this channel at high voltage level is discharging internally (we had not observed this behavior). They will have to repair it at their laboratory in Italy, the board Serial Number 0027 was then left to them on repair and it will be shipped back within the first week of June. This board was a spare one for us, with the currently installed boards we cover already the needs of the detector (24 channels). 3 of the 4 Boards are hence now re-installed but not reconnected yet to the SHV cables. A test at low voltage was performed this afternoon to monitor possible evolution of offset values.
- **June 8th 2017:** The CAEN HV board A1580HDN Serial Number 0027 on repair is now back and installed in the mainframe. CAEN replaced the faulty channel 4 with a new one and installed the latest firmware.
- **June-August:** internal leakage current of the power supply units is increasing on average and has a clear dependency on external temperature. The flow of air in the mainframe is not homogeneous hence we observe a variation of the temperature dependency within different boards: board located on a outer slot of the mainframe suffers more than inner ones.
- **August 23rd 2017:** board 0, 2 and 4 are now fully working, they have been re-calibrated by CAEN Team so we can monitor the evolution of leakage current over time/temperature - better to do now so that we can check evolution over next night and let them know in case. board 11 (the one showing Ext-DIs faulty channel) has been taken for repair and CAEN will let us know by tomorrow - maybe they can repair it here. Board 12 (with Radial connector output) now is a spare but since this is fully connected to DB we can also monitor that too
- **August 24th 2017:** board 11 for repair since yesterday is now installed back in the mainframe. all channels were calibrated by CAEN (offset null for current at $V_{set}=0$). All channels are now floating (no cables connected) and under test to monitor the evolution of residual leakage current. CAEN suggested to do those tests with a not null voltage, so now 50 V are set on each channel.

- When the CAEN boards for the LEM were installed, the group from Kiev tested them and observed a non-zero current in several LEMs: **LEM 3 down, LEM 4 down, LEM 6 down, LEM 8 up, LEM 12 down.**
- During the HV tests in June and July this current was again observed, both during ongoing tests and when everything was disconnected. More LEMs showed a non-zero current compared to the tests by Kiev group.
- For periods with no tests, the current was identified as a non-constant offset of the CAEN power supply.



CAEN power supply:

From left to right: Board 0, Board 1, Board 2

The LEM are ordered in logical order: first LEM 1 Up, then LEM 1 down, LEM 2 up, LEM 2 down etc.

Board 0: LEM 1 up, ... , LEM 4 down

Board 1: LEM 4 up, ... , LEM 8 down

Board 2: LEM 9 up, ... , LEM 12 down

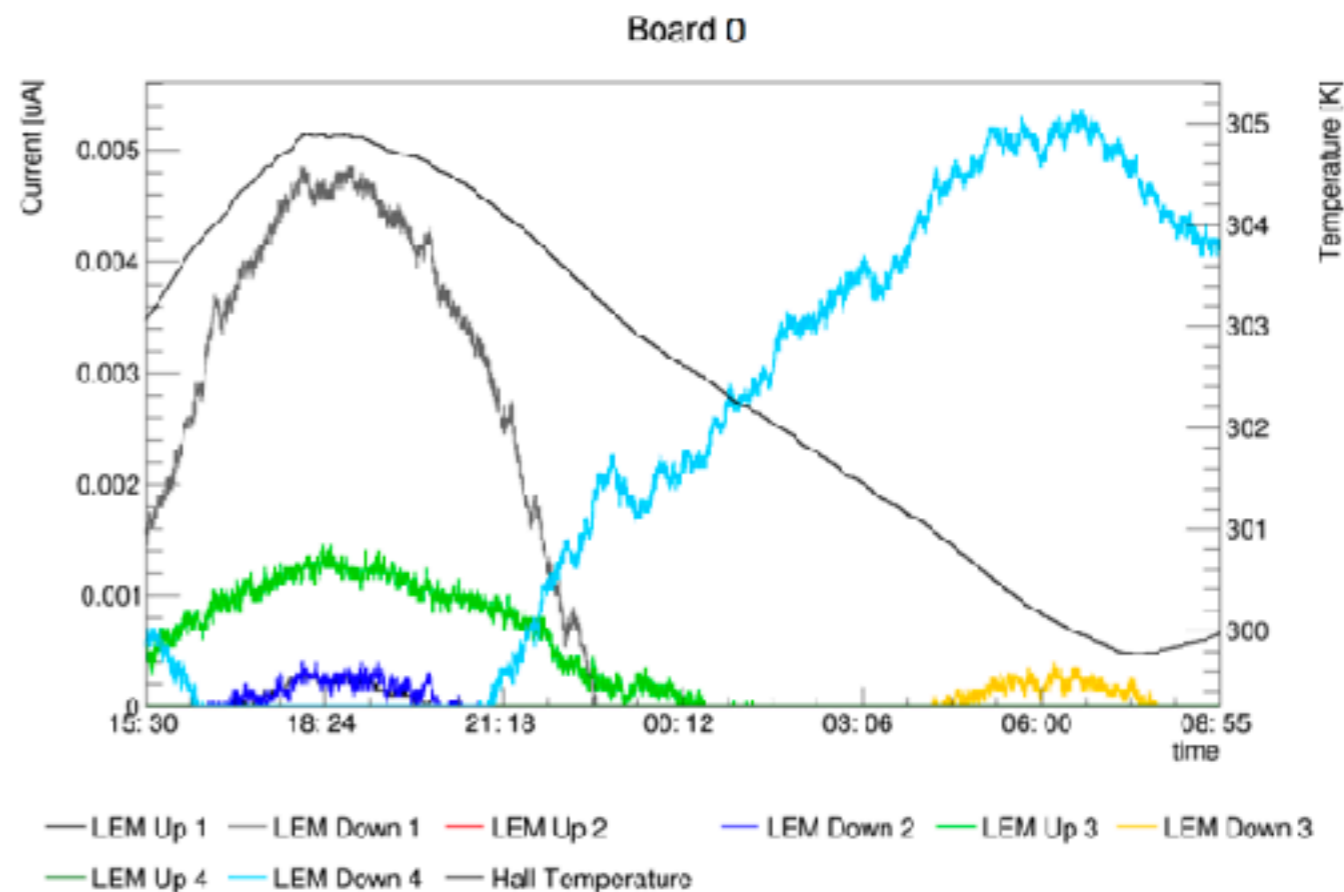

Affected LEMs: LEM 1,3, 7,8,12 up and down LEM 2, 4, 6 down

1) The current is (anti-)correlated to the hall temperature. (plot for the period of 07.07.2017 – 09.07.2017)

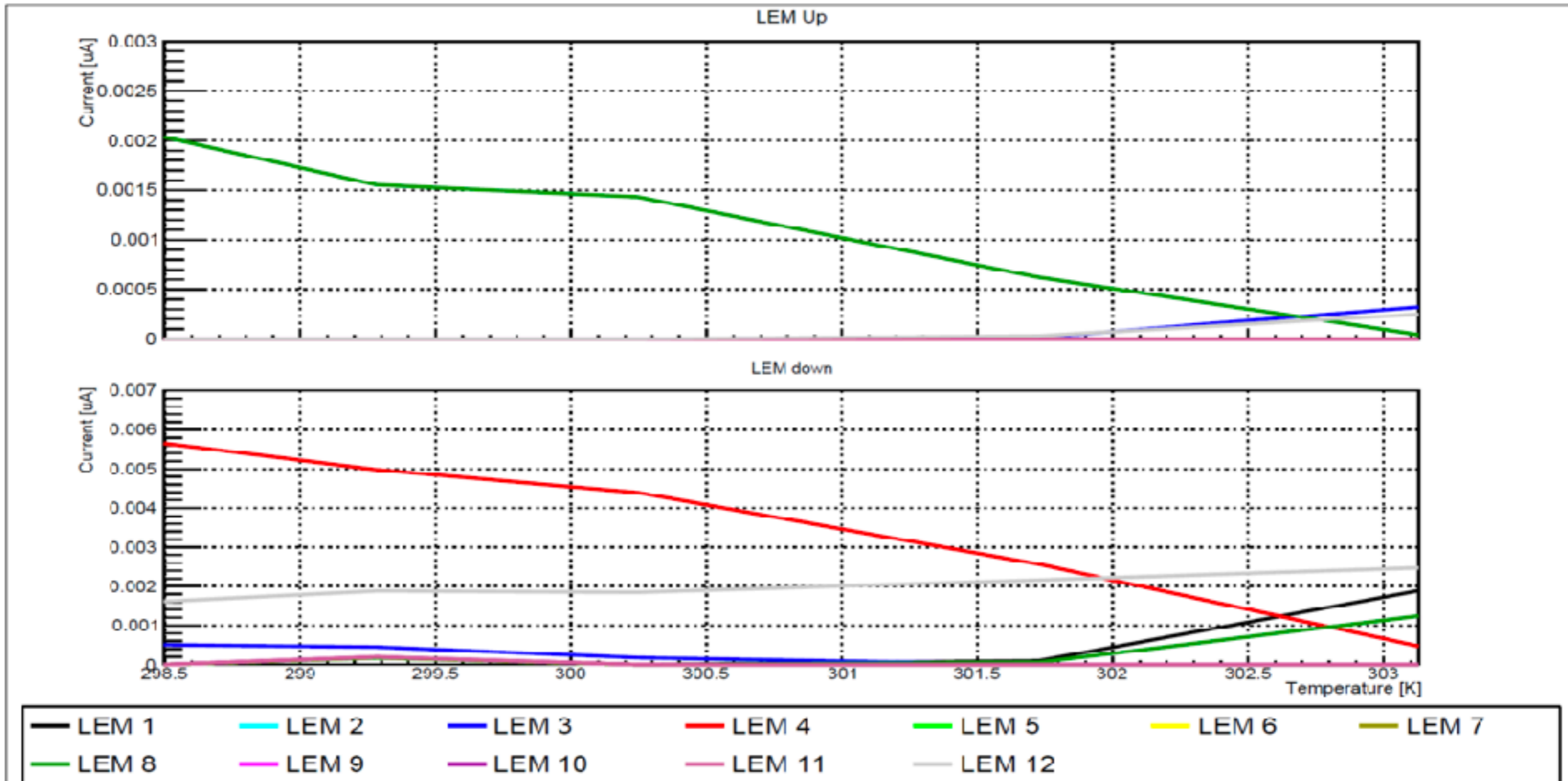

2) The current is higher on some LEM (see table) and the current drops from Board 0 to Board 2.

Board 0

Board 1

Board 2

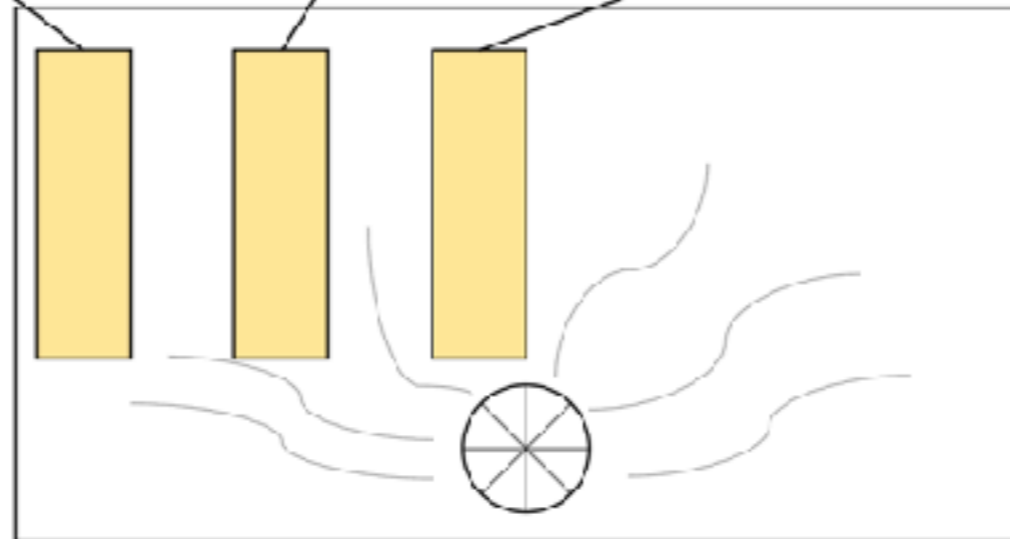
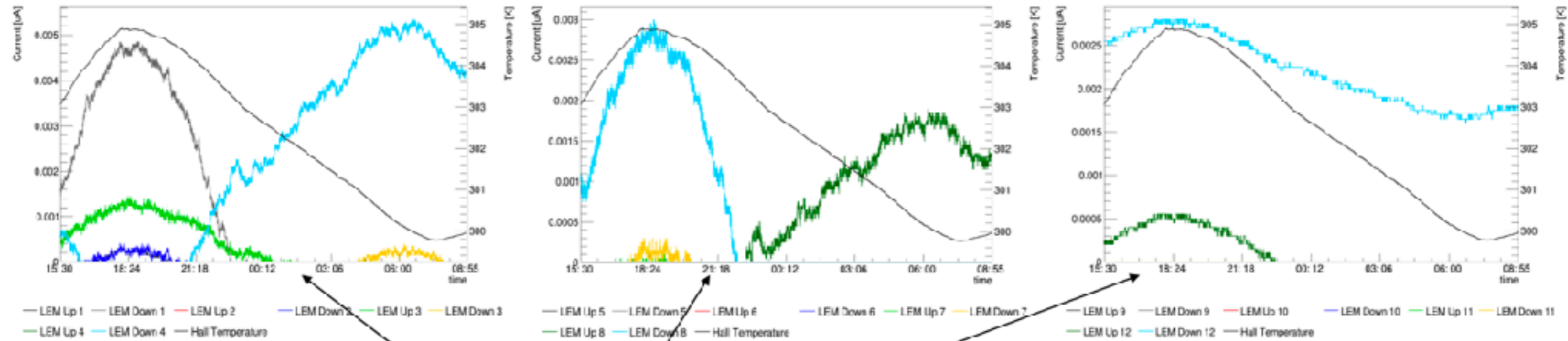

Fan providing a uniform air flow

1) The slope of the current oscillations does not seem to be affected by the HV. However for some LEM the absolute value of the leakage current can change. For example we start seeing a current on LEM 6, which we were not seeing before. This current is anti-correlated to the temperature and behaves like the other leakage currents.

- Test 1: Cathode: 20 kV, Grid: 1.0 kV, LEM down: 1.0, LEM up: 0 kV
- Test 2: Cathode: 20 kV, Grid: 2.5 kV, LEM down: 3.0 (corner: 2.6 kV), LEM up: 0.2 kV
- Test 3: Cathode: 20 kV, Grid: 0.5 kV, LEM down: 1.0, LEM up: 0 kV



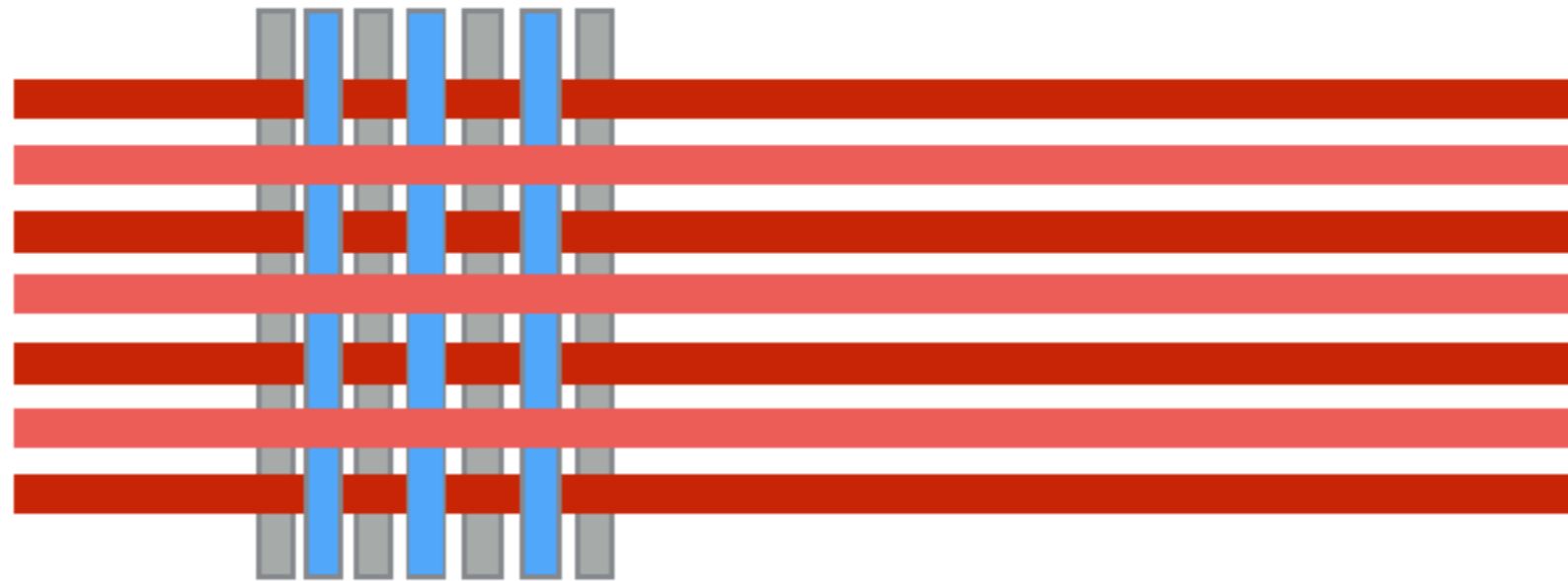

	Slope Test 1	Slope Test 2	Slope Test 3	Slope no HV	
LEM 3 down	-0.40 nA/K	-0.45 nA/K	-0.47 nA/K	0.47 nA/K	No obvious difference.
LEM 4 down	-1.07 nA/K	-1.20 nA/K	-1.35 nA/K	-1.10 nA/K	Difference of 0.1 nA.
LEM 6 down	-0.14 nA/K	-0.14 nA/K	-0.13 nA/K	/	
LEM 8 up	-0.57 nA/K	-0.39 nA/K	-0.59 nA/K	-0.50 nA/K	No obvious difference.

Current at hall temperature T = 298K

	Current Test 1	Current Test 2	Current Test 3	Current no HV	
LEM 3 down	1.0 nA	0.9 nA	1.0 nA	1.0 nA	No obvious difference.
LEM 4 down	5.25 nA	4.1 nA	5.3 nA	7.0 nA	Absolute current lower.
LEM 6 down	0.4 nA	0.3 nA	0.2 nA	/	New current.
LEM 8 up	1.7 nA	1.7 nA	2.45 nA	1.75 nA	No obvious difference.



order of mounting:

- | | | | |
|---|-----|---|-----|
|  | 1st |  | 3rd |
|  | 2nd |  | 4th |

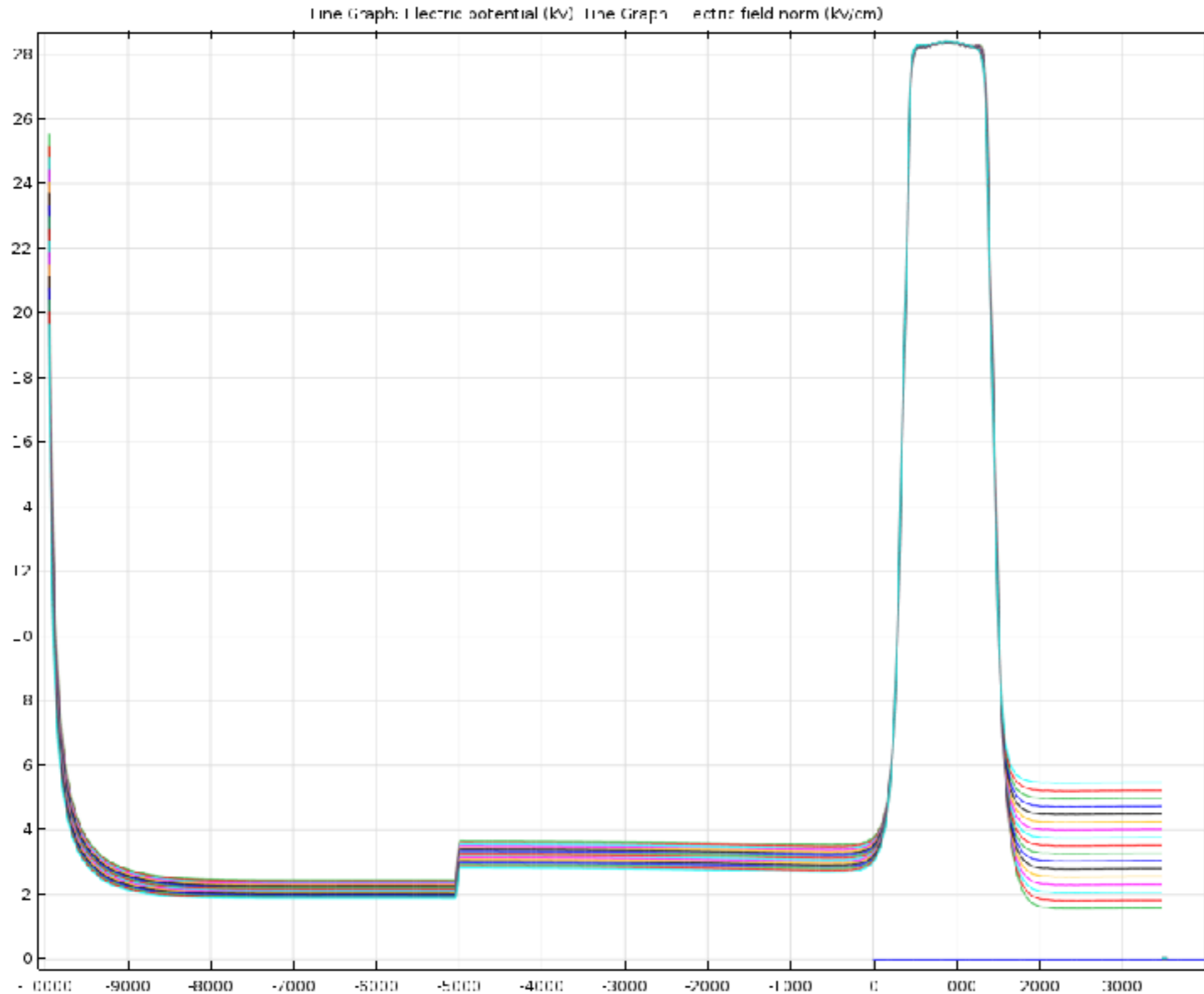

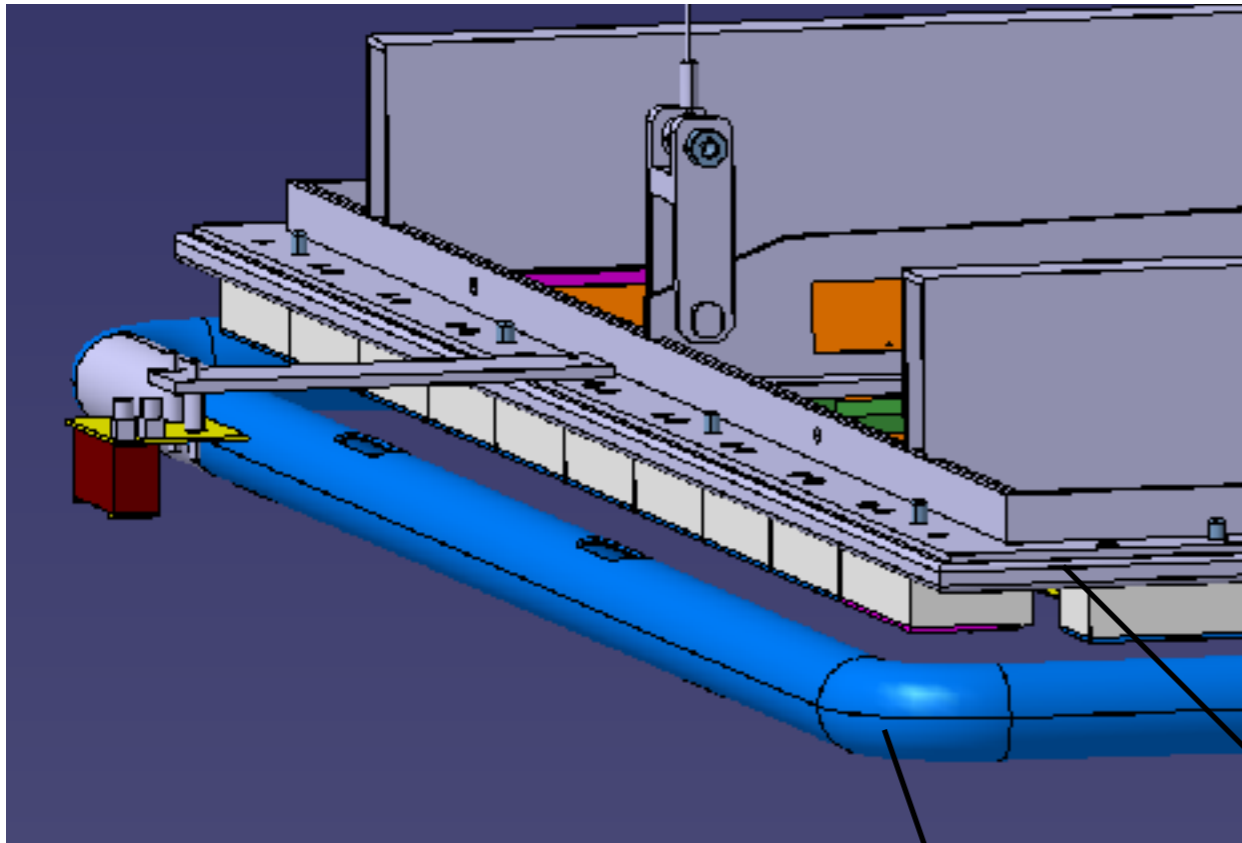

**First field shaper
At -7.5 kV**

Ground frame

**Maximum field of ~8
kV/cm**

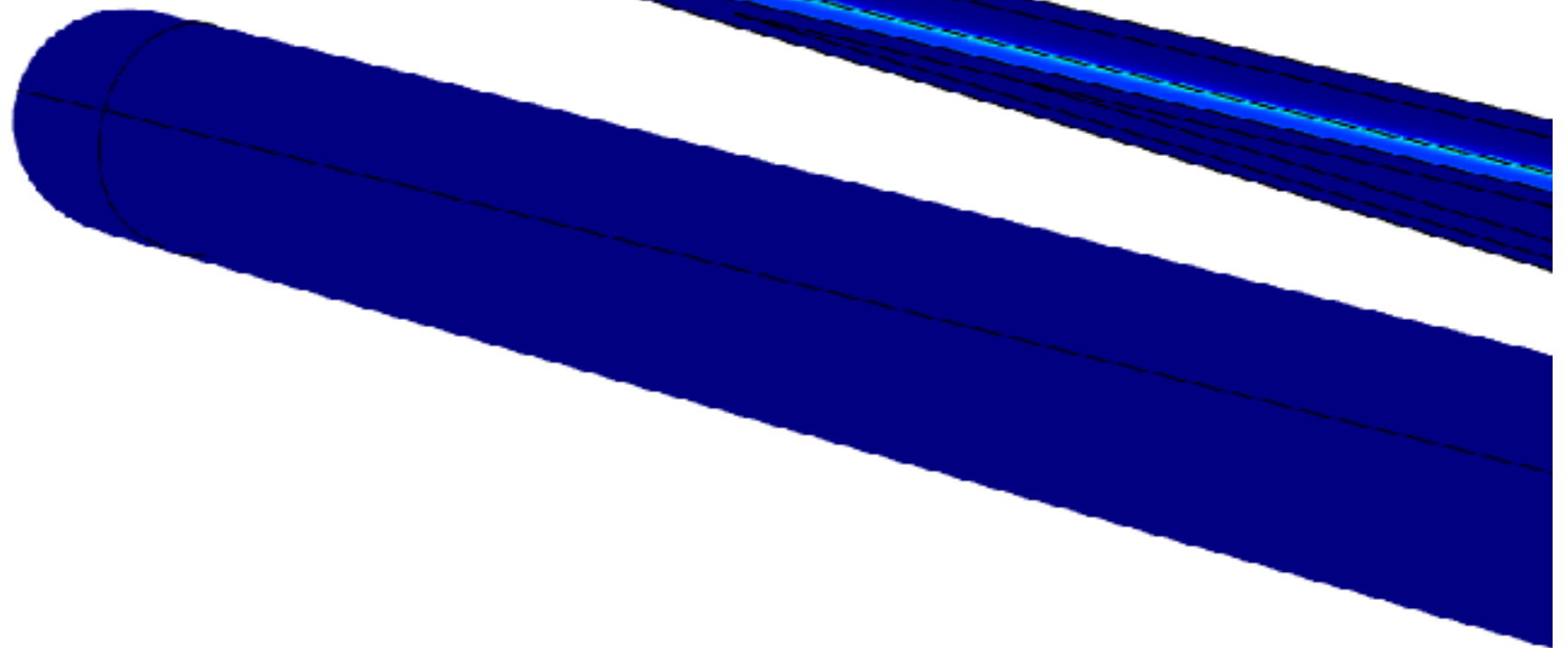

Induction field 1 kV/cm

Induction field 3 kV/cm

Induction field 5 kV/cm

MenUp[1]=200 Surface: Electric potential (V) Streamline: electric field

MenUp[2]=500 Surface: Electric potential (V) Streamline: Electric field

MenUp[3]=1000 Surface: Electric potential (V) Streamline: electric field

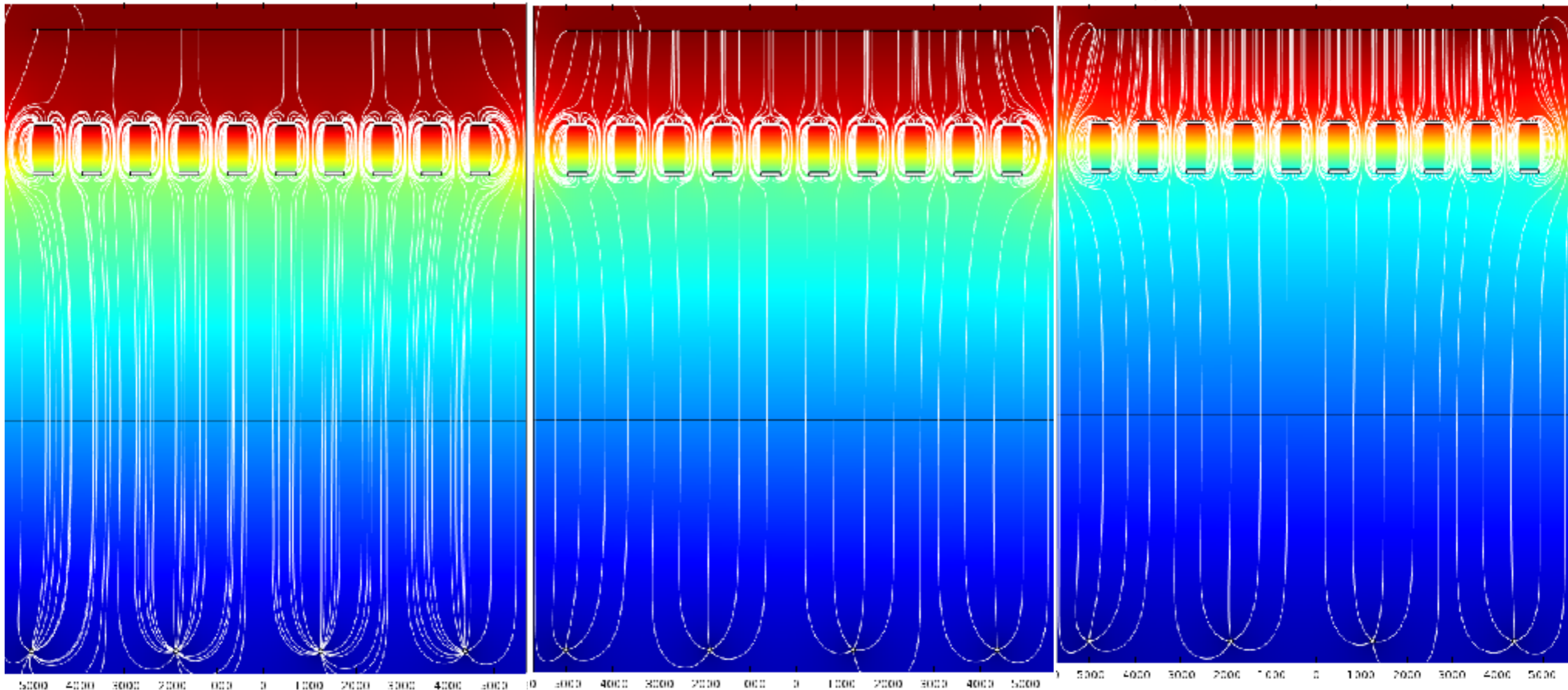

Grid at the nominal voltage, 6.5 kV and amplification of 30kV/cm

5) Grid HV connection inside

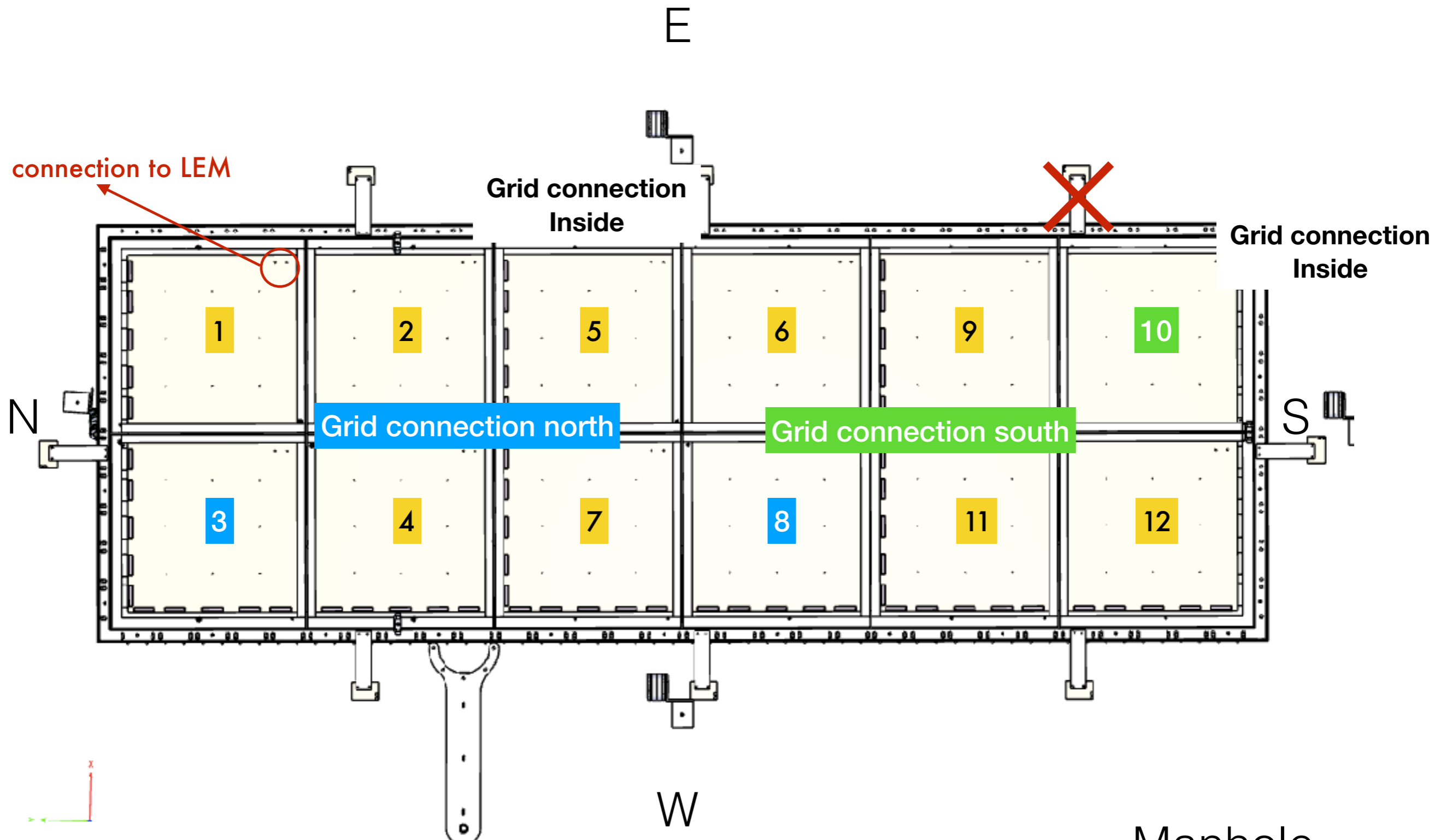

The grid tripped ramping up to 4,8kV Tripped between 3,8 and 4kV corner

Manhole

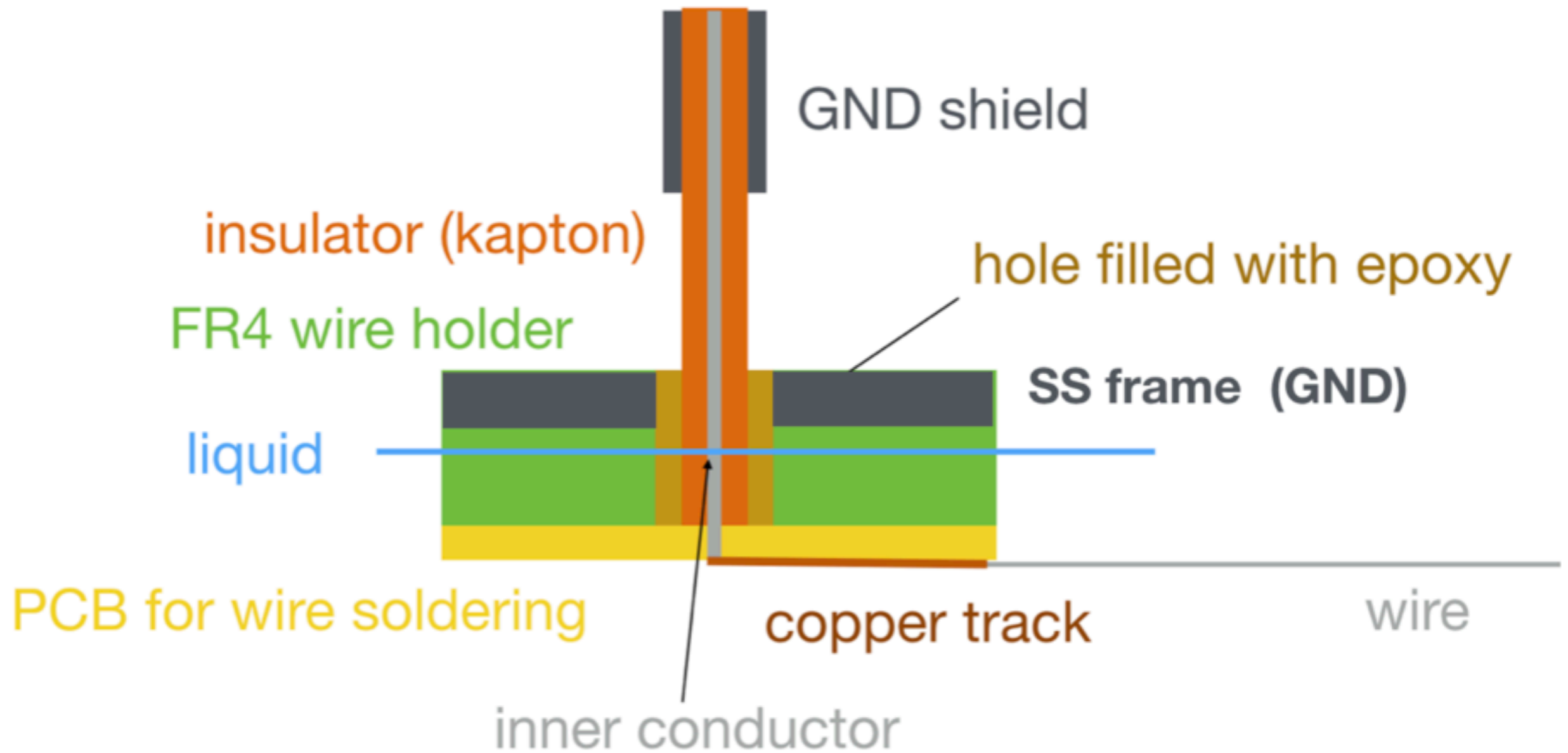

Level Meters

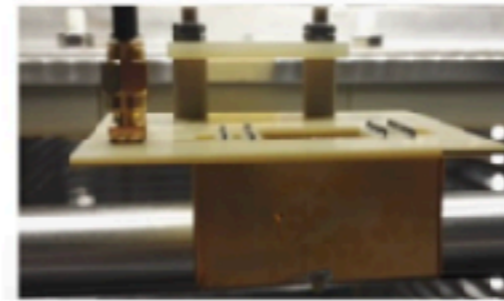

Not working 2 chan

25 mm: Fully immersed

0 mm: No LAr

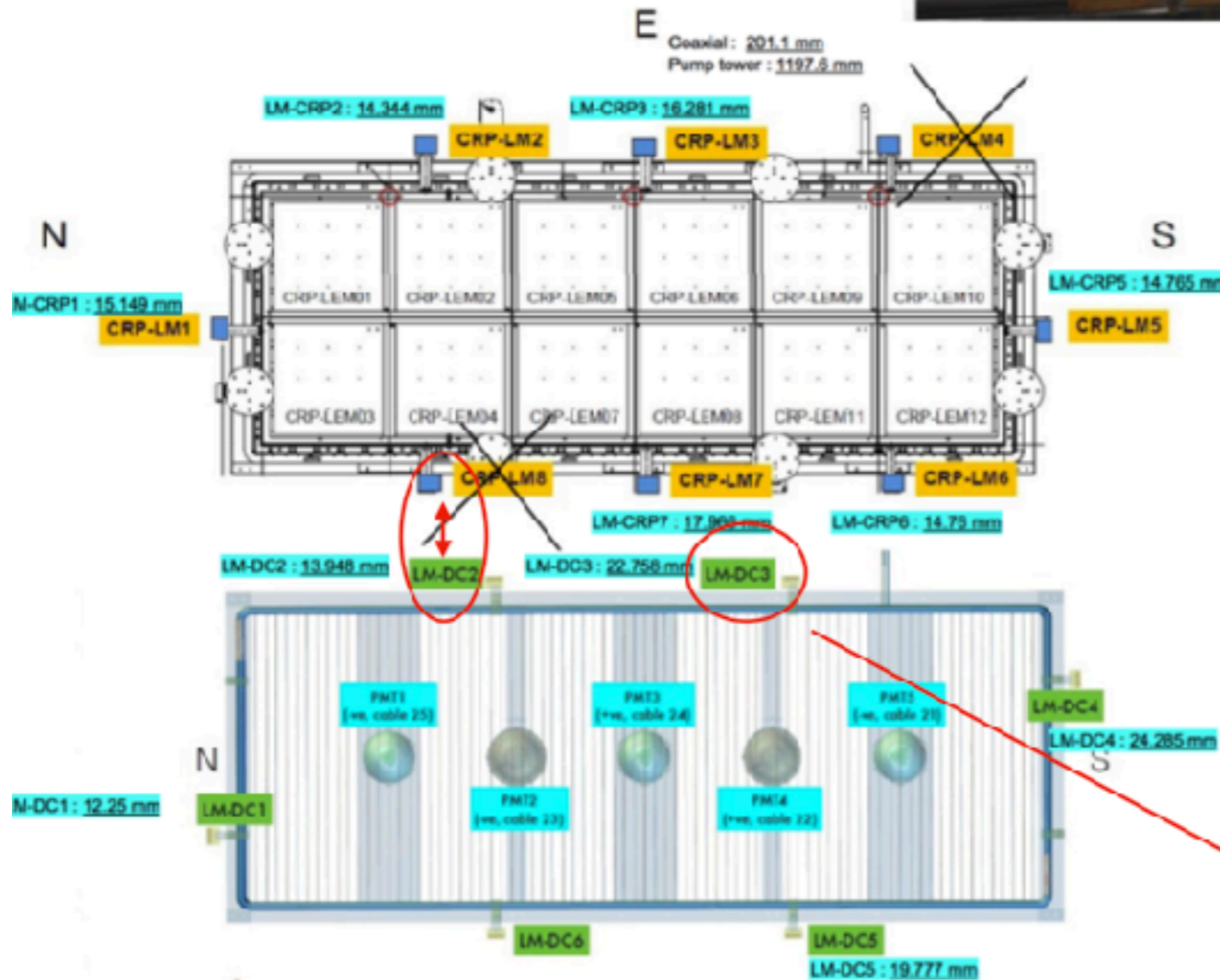

7 Level meters on the CRP

4 Level meters on the drift cage



Again :

- LM-DC2 was disconnected and replaced by LM-CRP8
- LM-DC3 is visible on the camera

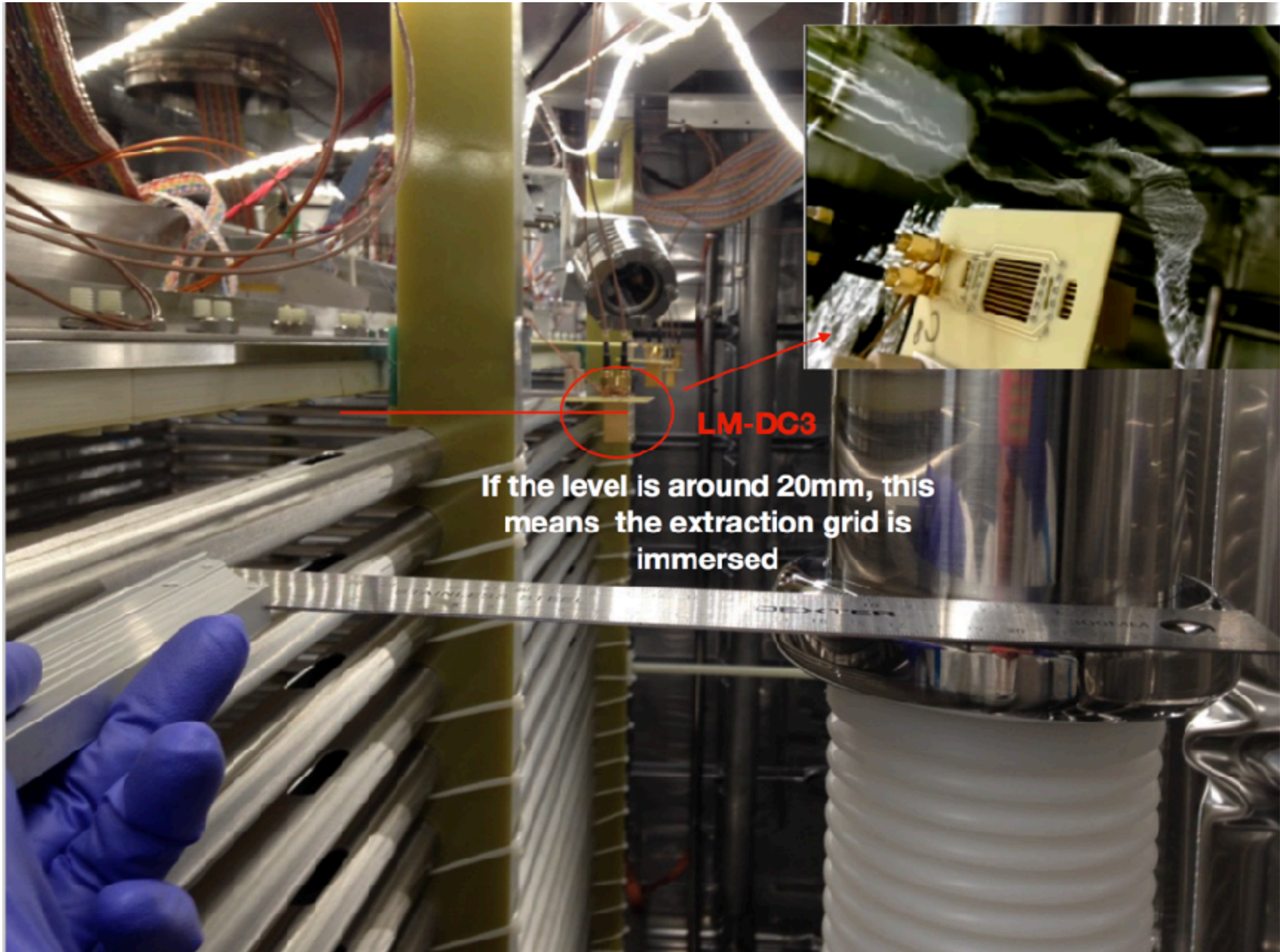

LM drift cage

At least all LM along drift cage need to be immersed more than ~5 mm to guarantee that the FFS is completely immersed

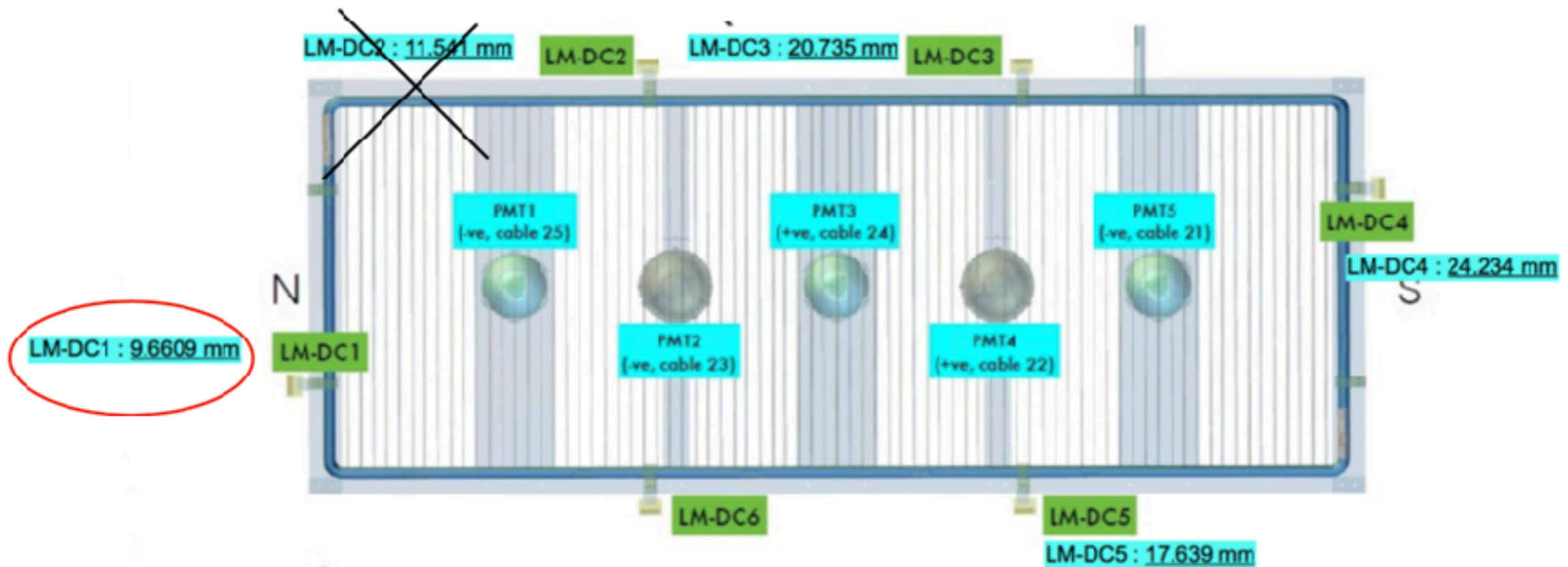
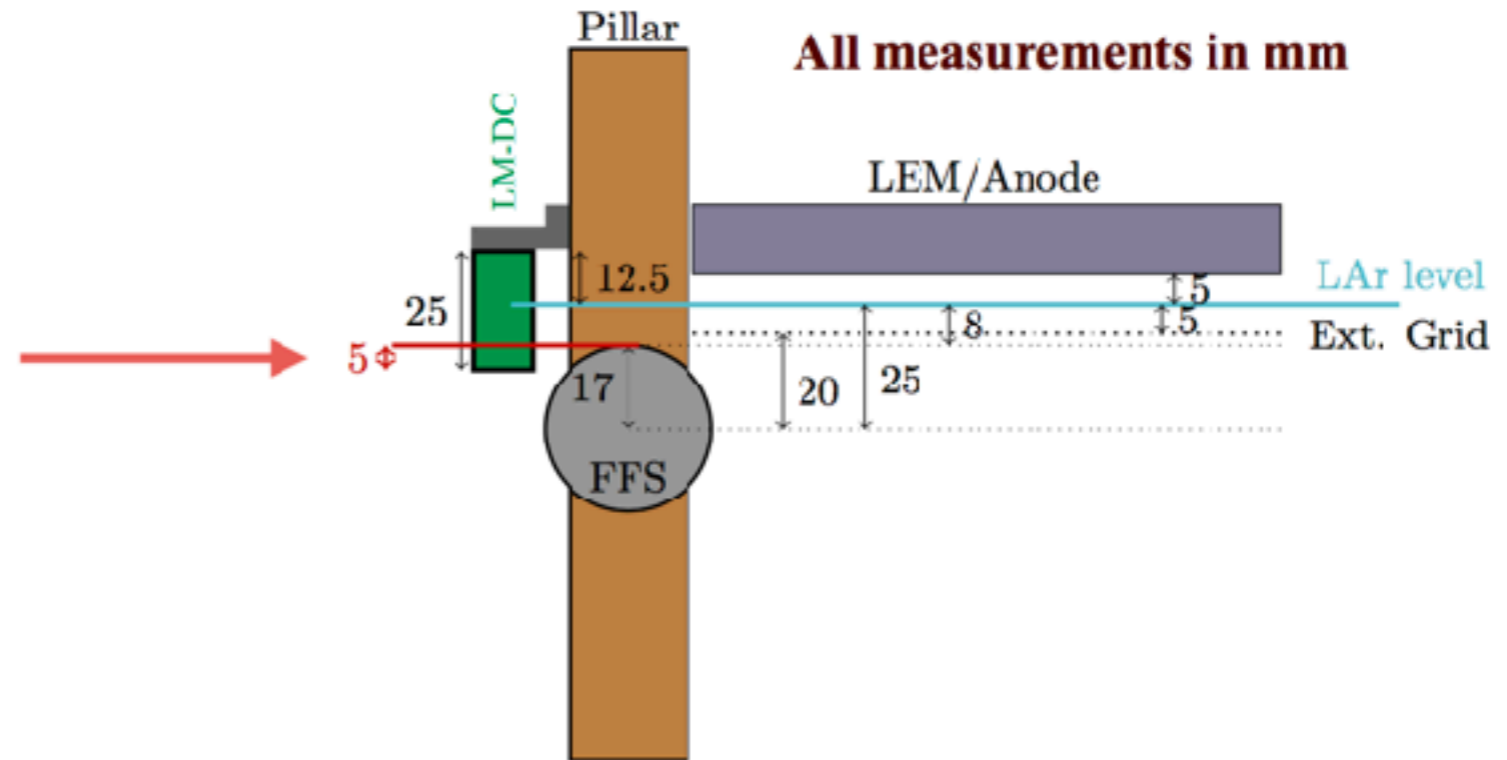

Laura Manenti
measurement

Measurement A (distance FFS to extraction grid)

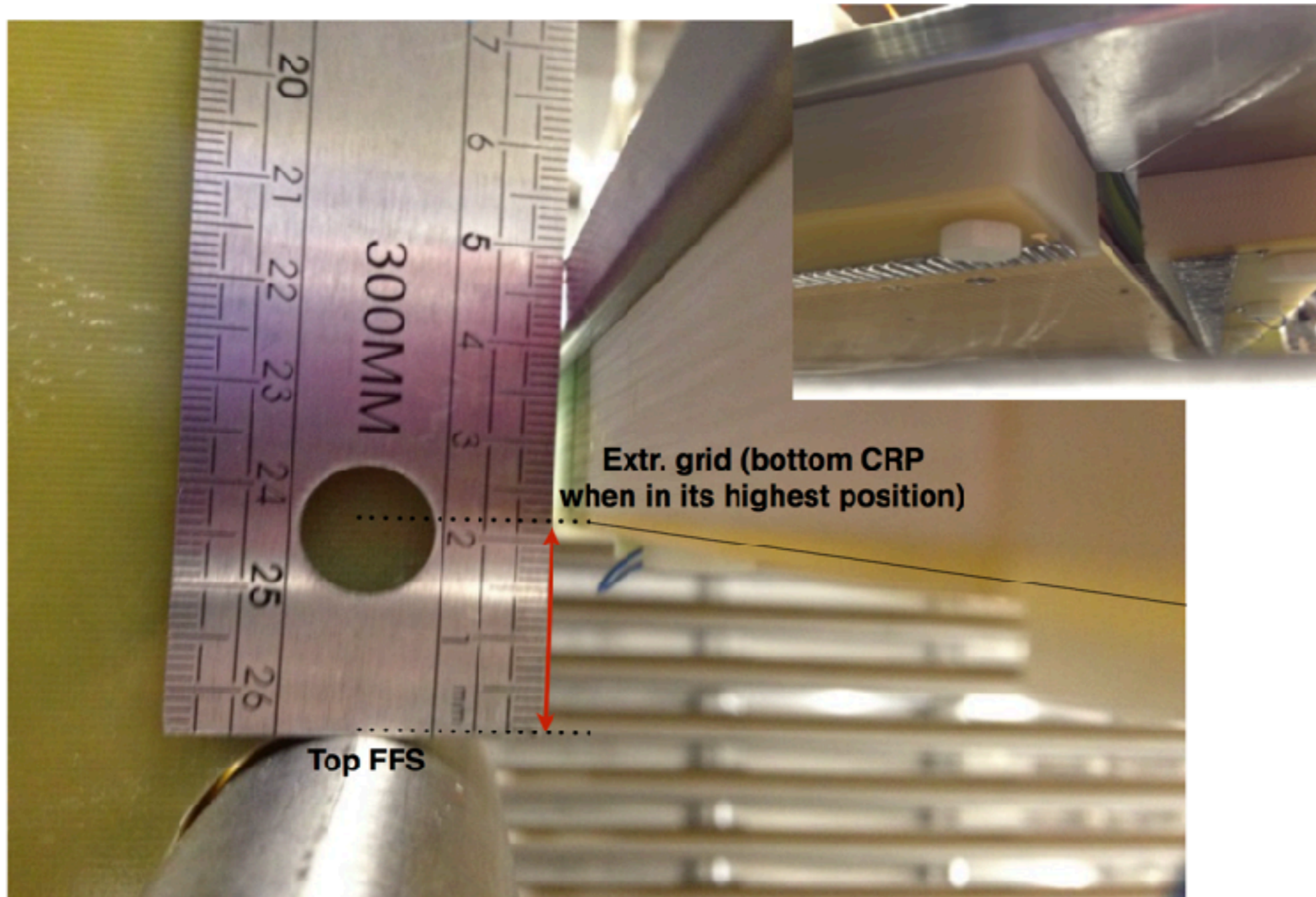

LM-CRP

Laura Manenti
measurement

Distance from extraction grid to top LM-CRP - Measurement B -

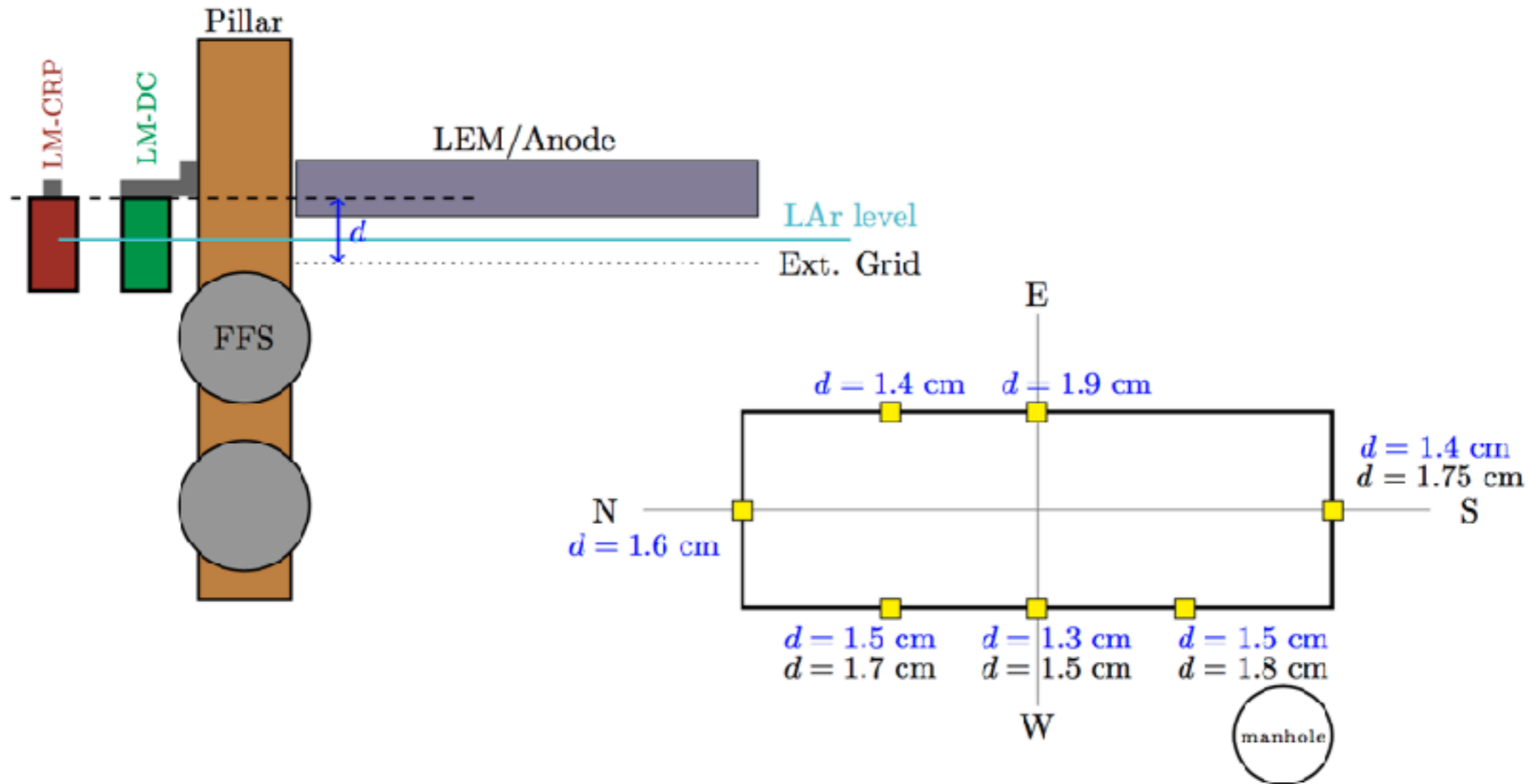

Sebastien's measurements

Laura's measurements

(could not measure E side as inaccessible)

CRP at its highest point.
All d should be = **1.75 cm**.
Within measurement uncertainty,
all LM are aligned with the CRP

Laura Manenti
measurement

**- Measurement C -
(FFS to top LM-DC)**

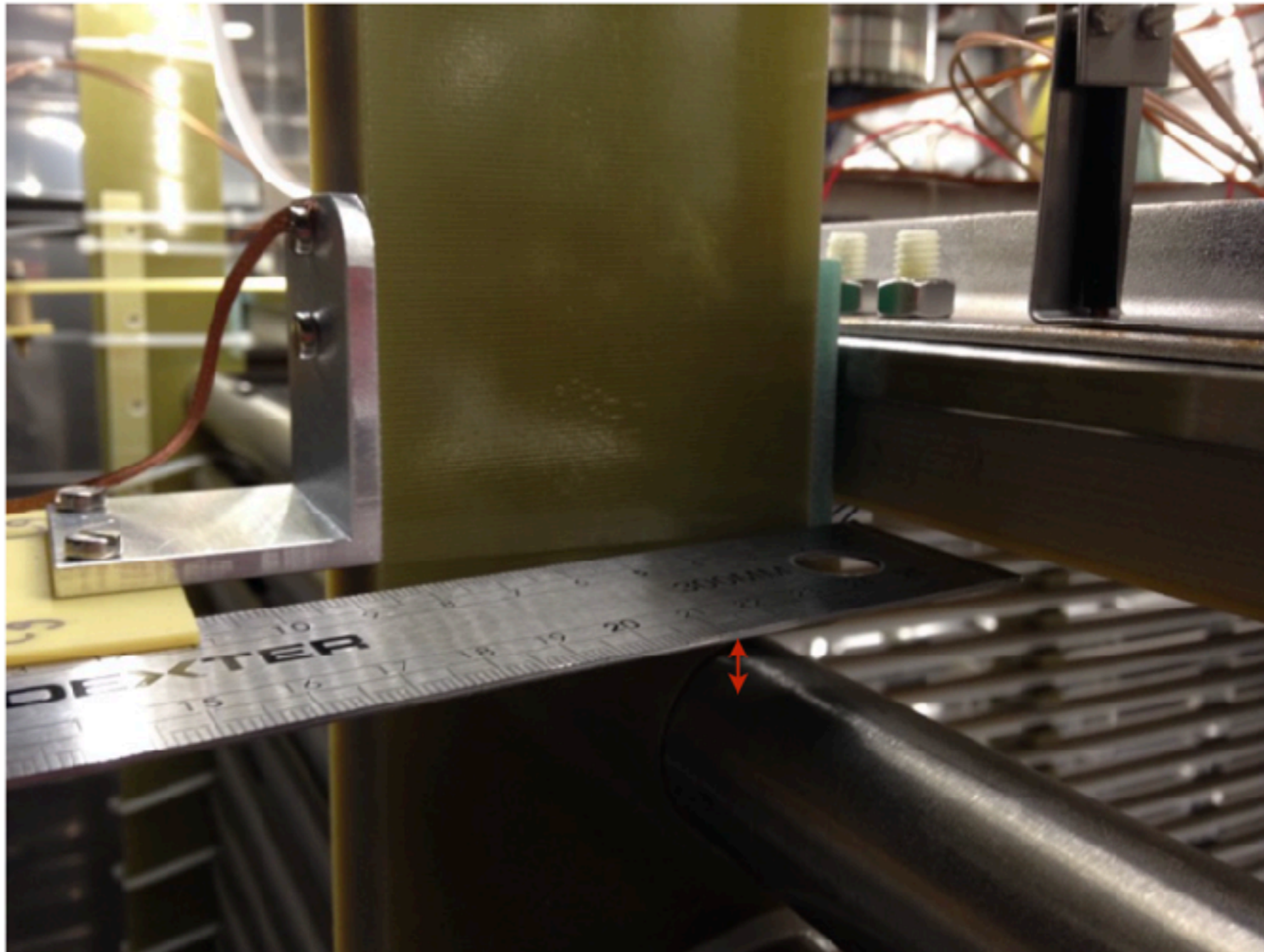

Laura Manenti
measurement

Distance FFS (top tube) to top LM-DC (Level Sensor Drift Cage) - Measurement C -

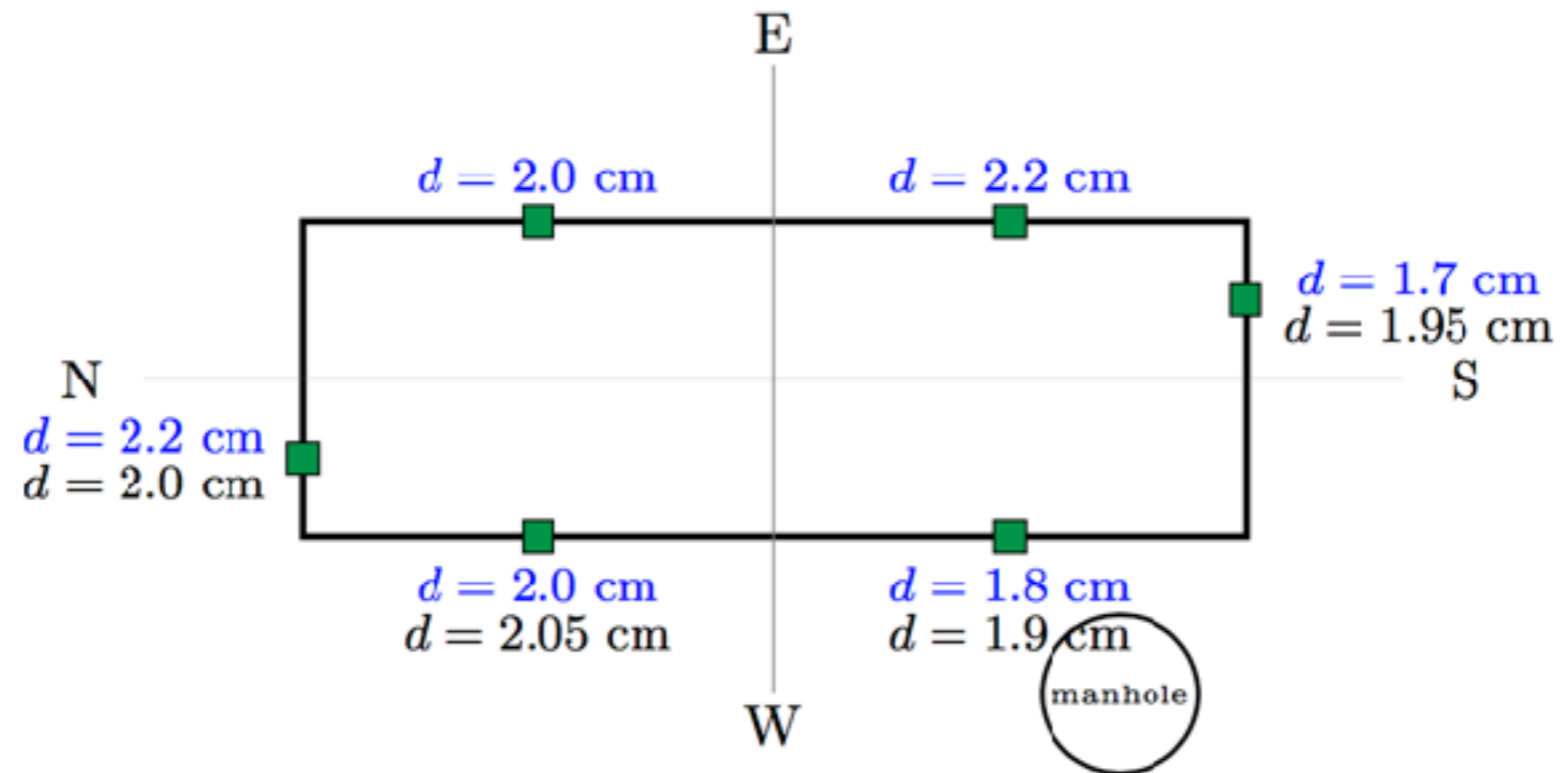
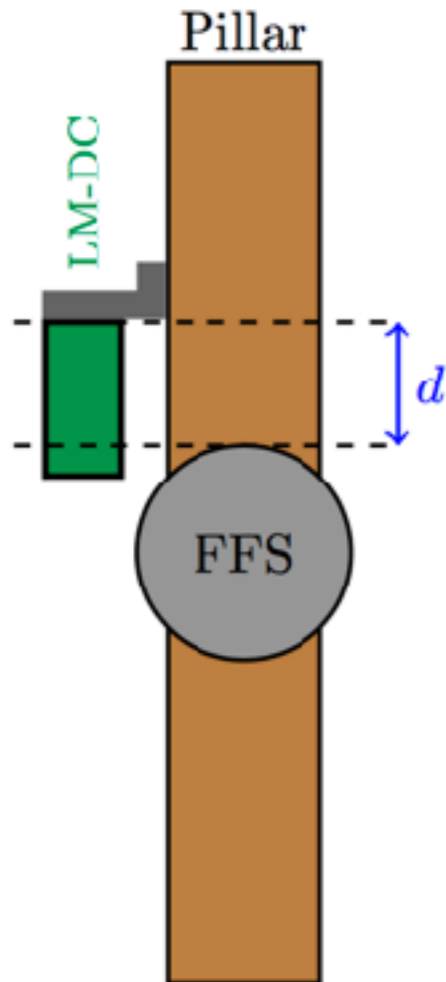

All d should be = **2.05 cm** (i.e. LM-DC aligned with DC).
They are not. Also DC is tilted (as seen before).
Because of misalignment and tilt :
⇒ **sensor on the N side [LM-DC1] is the highest**
⇒ **sensor on the S side [LM-DC4] is the lowest**
↳ cf elog#219, LM-DC4 was the first one to see LAr

Minimum level of LM-DC to have the FFS immersed

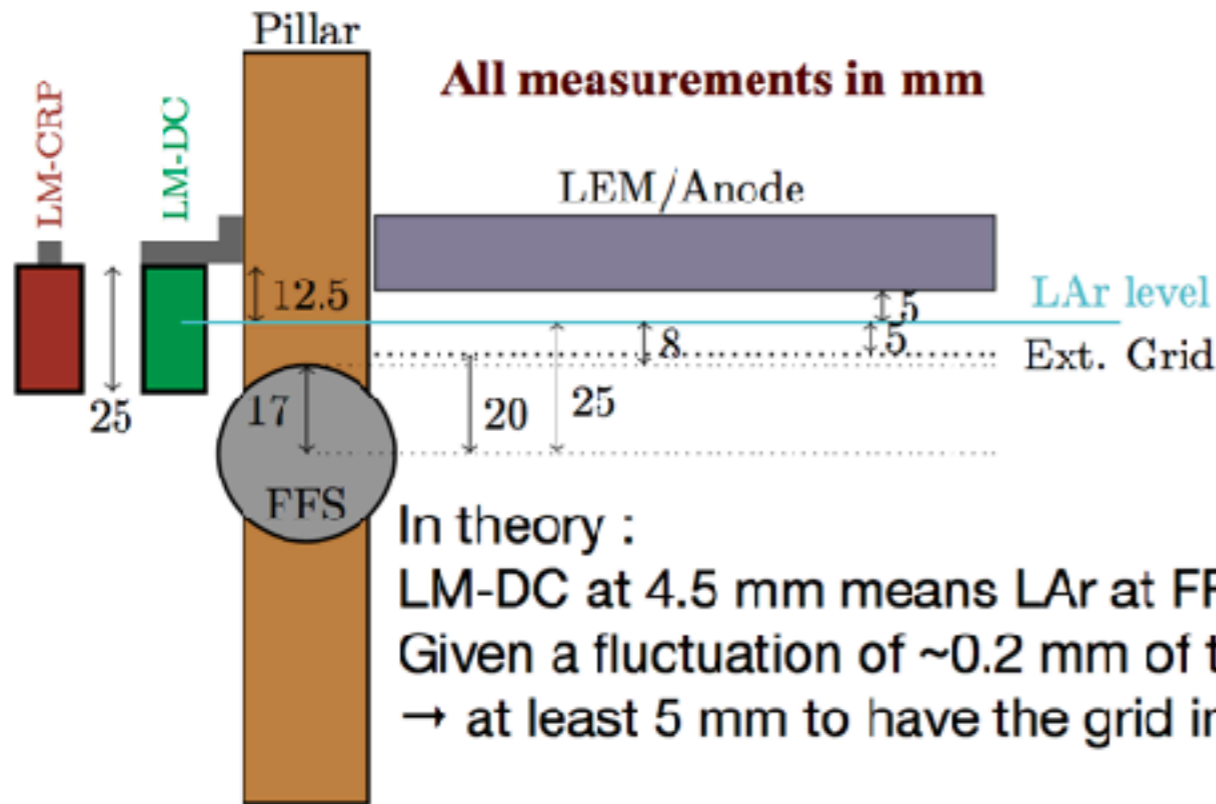

In theory :
 LM-DC at 4.5 mm means LAr at FFS
 Given a fluctuation of ~0.2 mm of the liquid level
 → at least 5 mm to have the grid immersed

Given the LM-DC and Drift cage misalignments (being conservative) :

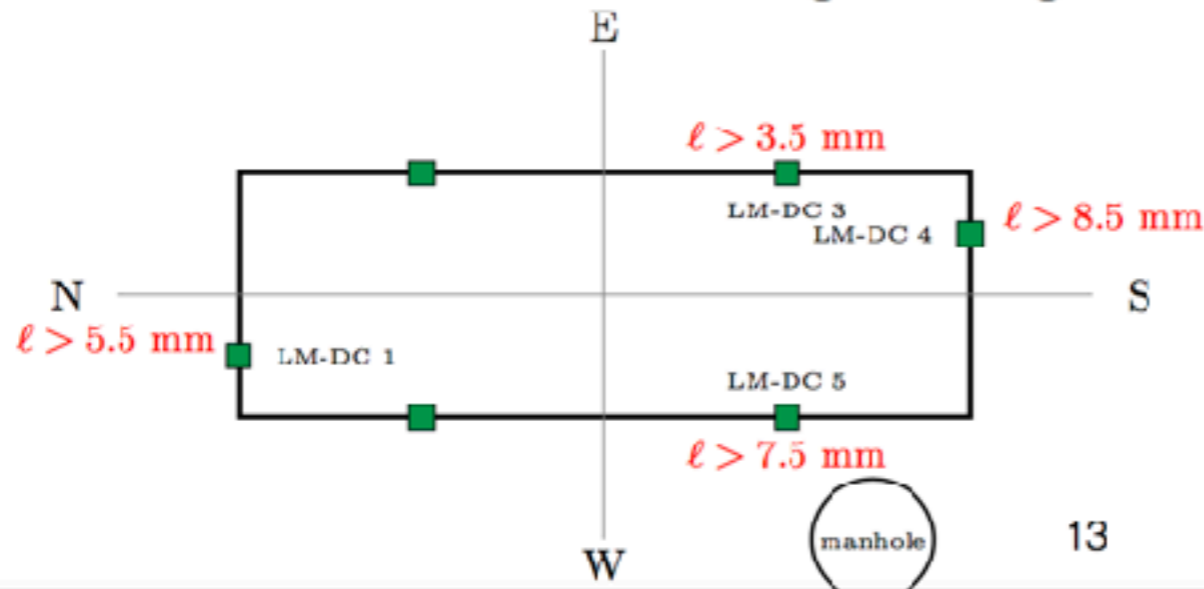

As DC is tilted :
 critical for LM-DC 1.
 LM-DC 3, 4 and 5 should be fine

Minimum level of LM-CRP to have the Extr. Grid immersed

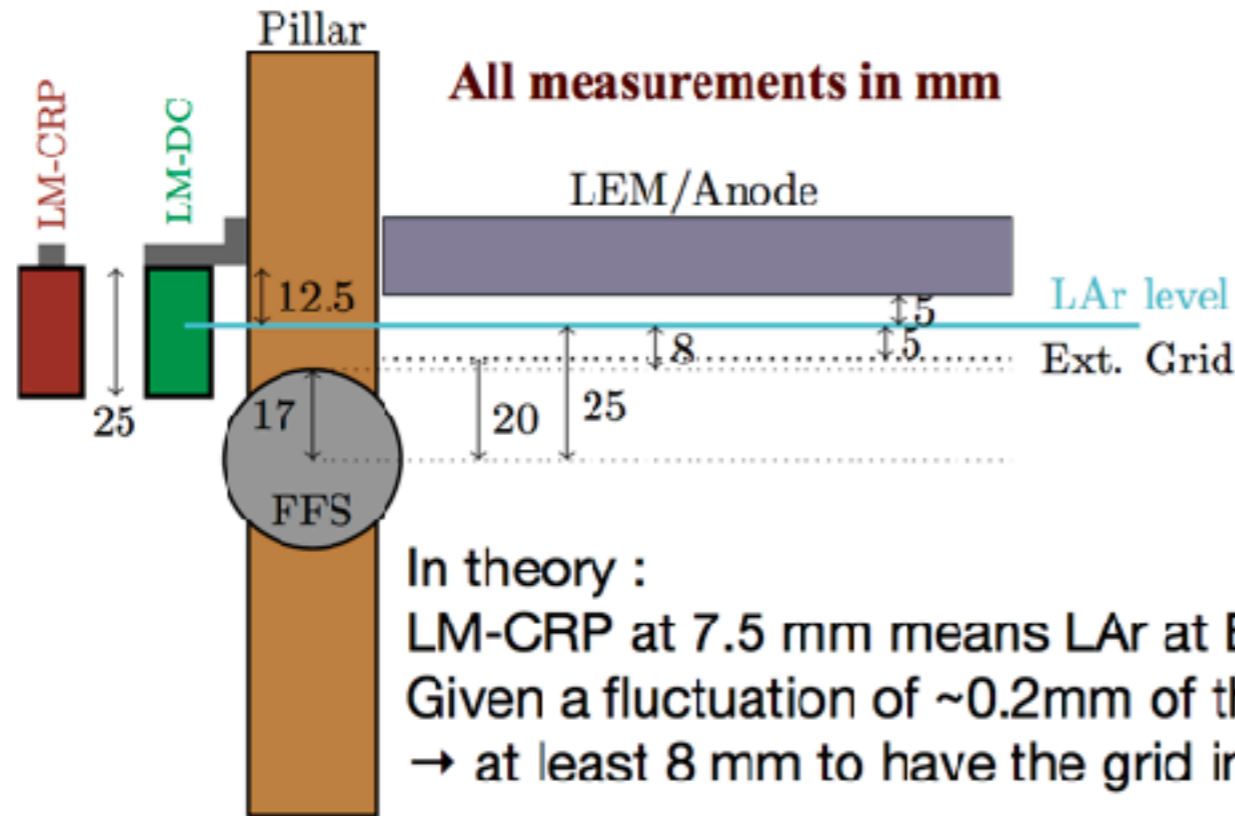

Given the LM-CRP and CRP misalignments (being conservative) :

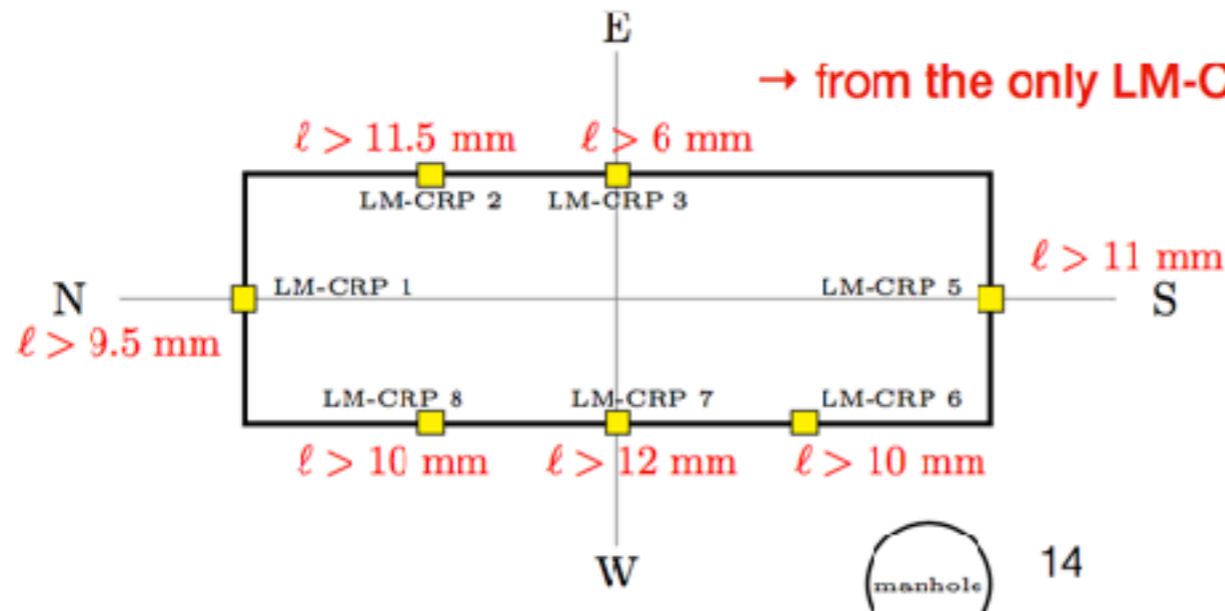

→ from the only LM-CRP position measurement, should be careful

Assuming CRP is in its nominal position.

CRP deformation - June 26 at 15:13 -

2D View from West side
(no possible misalignment taken into account)

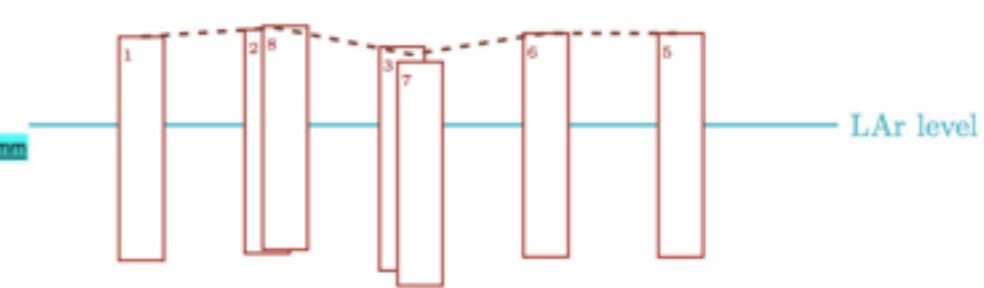
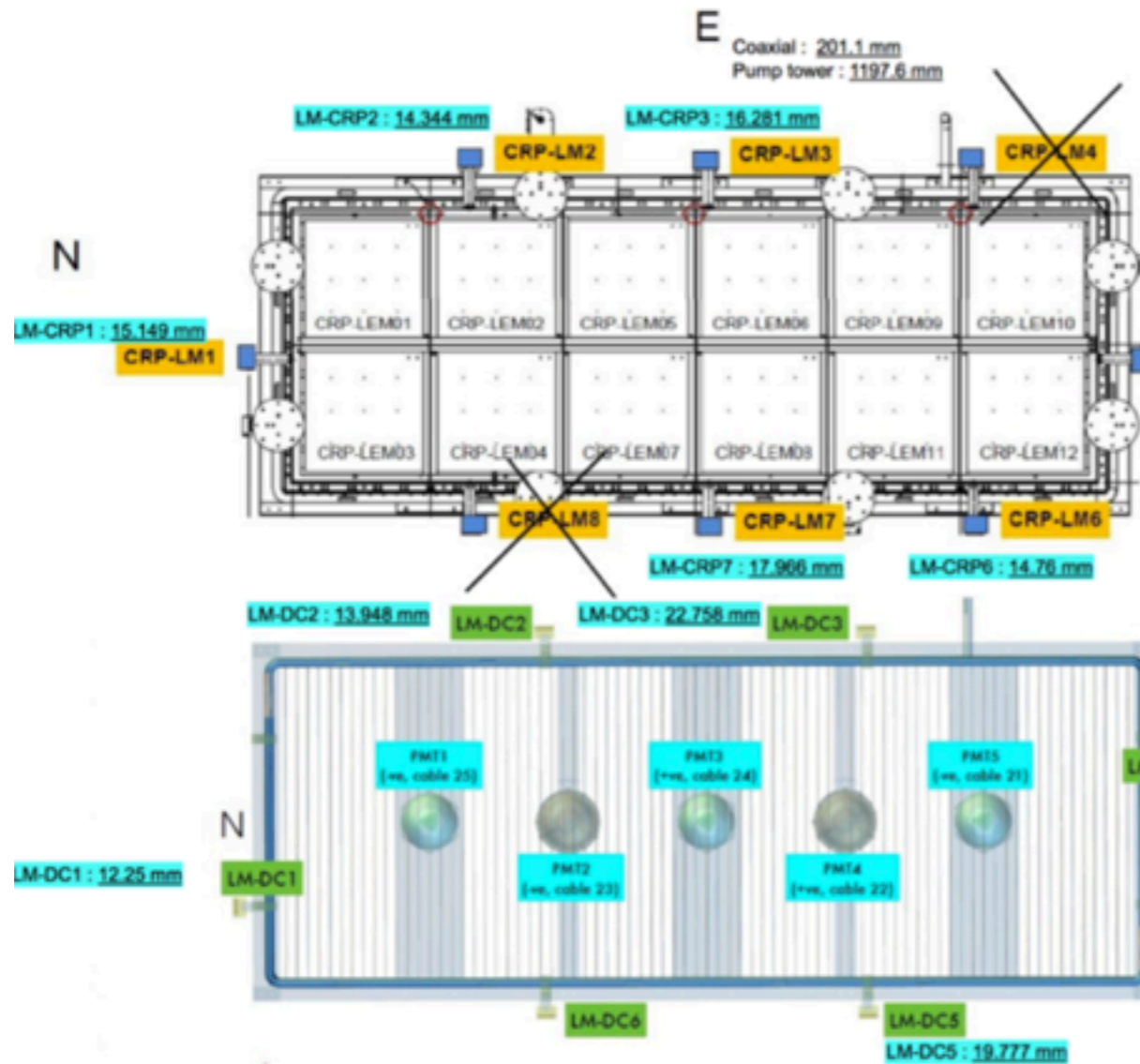

↳ Central part of the CRP is more immersed ?

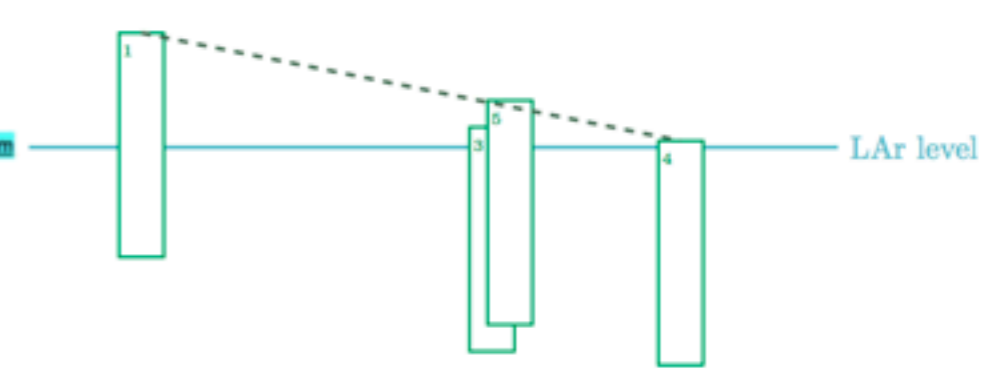

↳ Consistent with 4 mrad tilt
 $\text{asin}(12/3000) \sim 4 \text{ e-3 rad}$

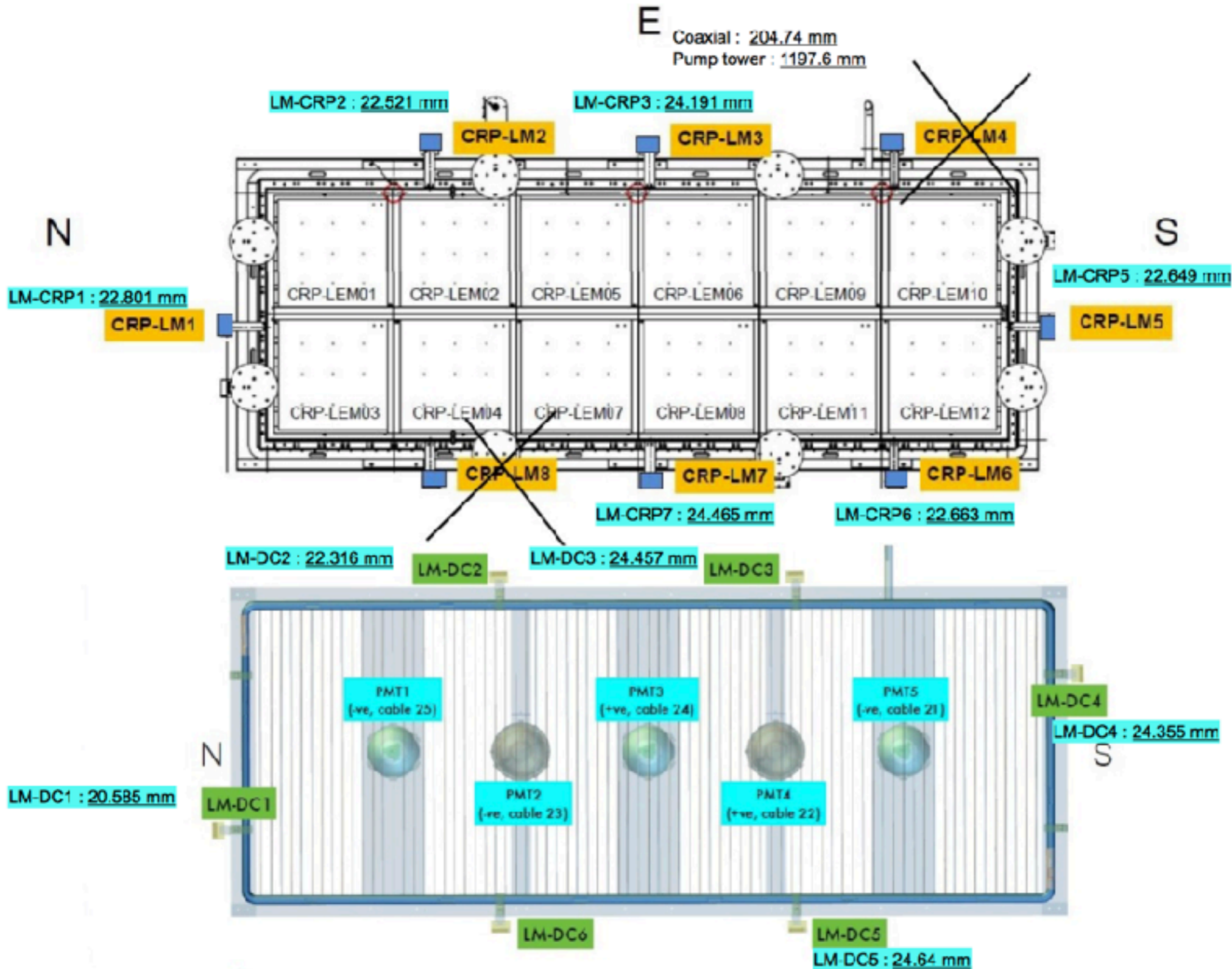

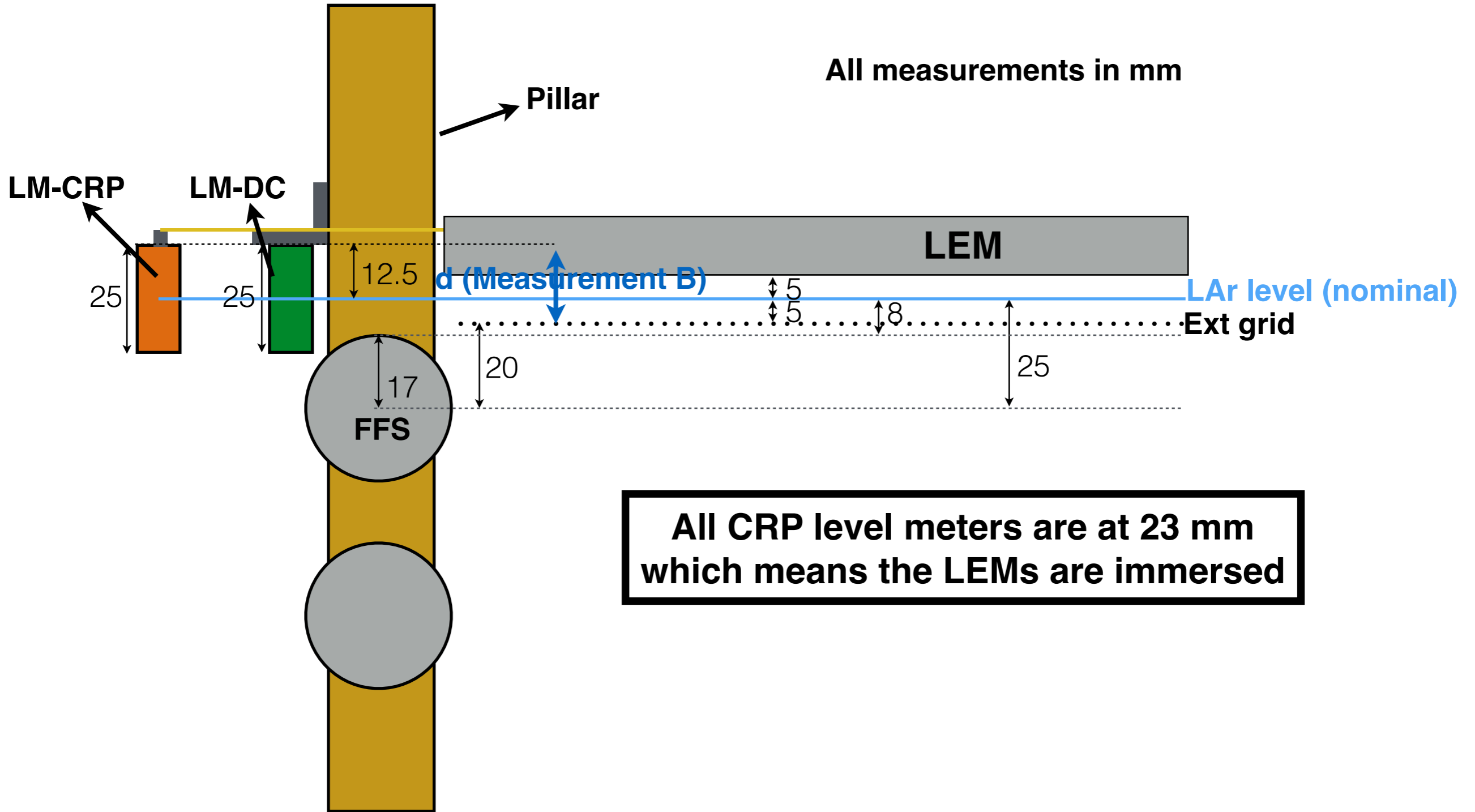

- TE0001: 280.54 K
- TE0002: 282.88 K
- TE0003: 284.8 K
- TE0004: 285.86 K
- TE0005: 288.73 K
- TE0006: 286.94 K
- TE0007: 284.82 K
- TE0008: 283.49 K
- TE0009: 281.55 K
- TE0010: 280.17 K
- TE0011: 277.2 K
- TE0012: 273.79 K
- TE0013: 270.78 K
- TE0014: 267.51 K
- TE0015: 263.63 K
- TE0016: 260.47 K
- TE0017: 257.27 K
- TE0018: 254.7 K
- TE0019: 251.3 K
- TE0020: 248.03 K
- TE0021: 244.27 K
- TE0022: 241.56 K
- TE0023: 238.33 K
- TE0024: 234.77 K
- TE0025: 234.03 K
- TE0026: 229.85 K
- TE0027: 226.65 K
- TE0028: 223.26 K
- TE0029: 219 K
- TE0030: 214.24 K
- TE0031: 209.44 K
- TE0032: 205.14 K
- TE0033: 200.46 K
- TE0034: 4364.4 K
- TE0035: 190.52 K
- TE0036: 185.79 K

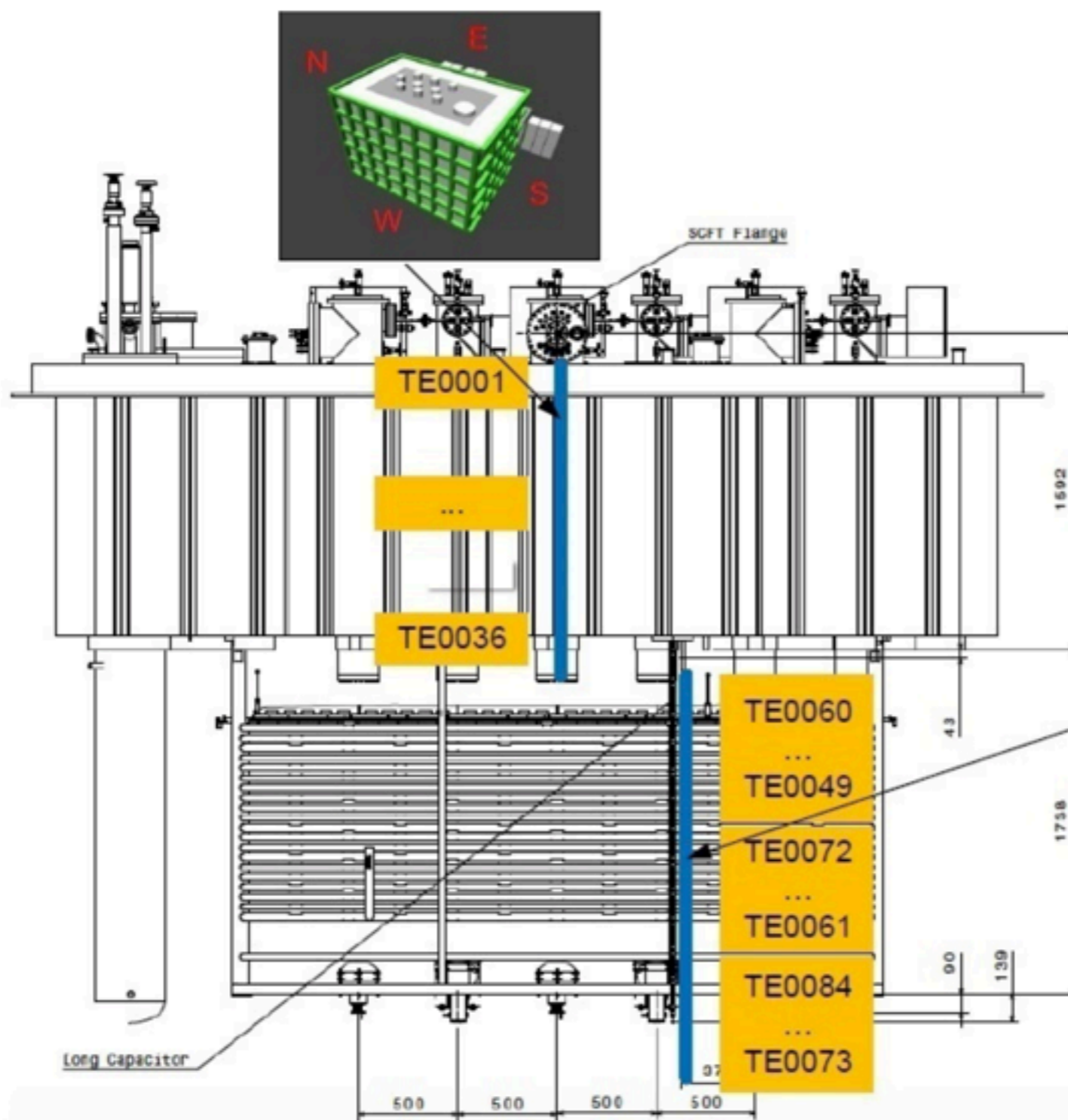

- TE0060: 126.09 K
- TE0059: 116.29 K
- TE0058: 106.26 K
- TE0057: 96.38 K
- TE0056: 87.428 K
- TE0055: 87.438 K
- TE0054: 87.476 K
- TE0053: 87.438 K
- TE0052: 87.484 K
- TE0051: 87.499 K
- TE0050: 87.554 K
- TE0049: 87.653 K
- TE0072: 87.485 K
- TE0071: 87.525 K
- TE0070: 87.552 K
- TE0069: 87.61 K
- TE0068: 87.524 K
- TE0067: 87.513 K
- TE0066: 87.551 K
- TE0065: 87.566 K
- TE0064: 87.56 K
- TE0063: 87.514 K
- TE0062: 87.547 K
- TE0061: 87.529 K
- TE0084: 87.558 K
- TE0083: 87.497 K
- TE0082: 87.513 K
- TE0081: 87.484 K
- TE0080: 87.508 K
- TE0079: 87.536 K
- TE0078: 87.624 K
- TE0077: 87.485 K
- TE0076: 87.534 K
- TE0075: 87.554 K
- TE0074: 87.521 K
- TE0073: 87.618 K



N

- Switch off the recirculation pump
- Capacitance measurements in GAR
- Change the VHV power supply to the 100 kV power supply.
- Functioning of the automatic frame adjustment system: Will be tested in the following weeks.

- The purity monitor can be installed
- Parallel and serial resistors for the LEMs
- Better resolution in the field cage current: change the power supply to the 100kV PSU.
- Recalibrate coaxial level meter.
- Orientate cameras: one can be oriented towards the grid HV connection