

The Quadropix DEPFET concept

A. Baehr^a, A. Feller^b, P. Lechner^a, J. Ninkovic^a,
R. Richter^a, F. Schopper^a, J. Treis^a

^a*Semiconductor Laboratory of the Max-Planck-Society (MPG HLL), Otto-Hahn-Ring 6, 81739 Munich, Germany*

^b*Max-Planck-Institute for Solar System Research, Justus-von-Liebig-Weg 3, 37077 Goettingen, Germany*

13th Trento Workshop 2018, Munich



This project is supported by the European Commission's H2020 Programme for the period June 2015 – June 2018 under the Grant Agreement n°653982

- GREY - Getting Ready for the European Solar Telescope



● GREY

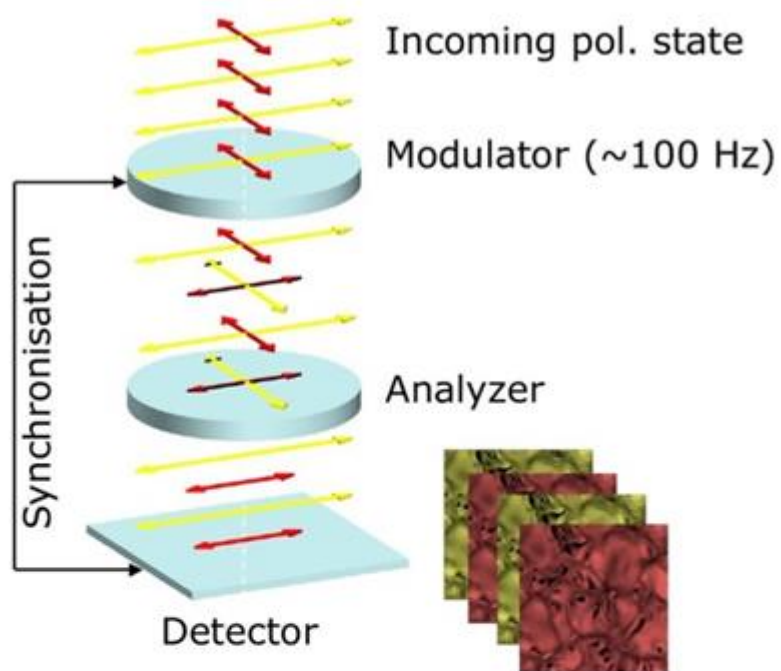

Intensity = + =

Polarization = - =

● GREST

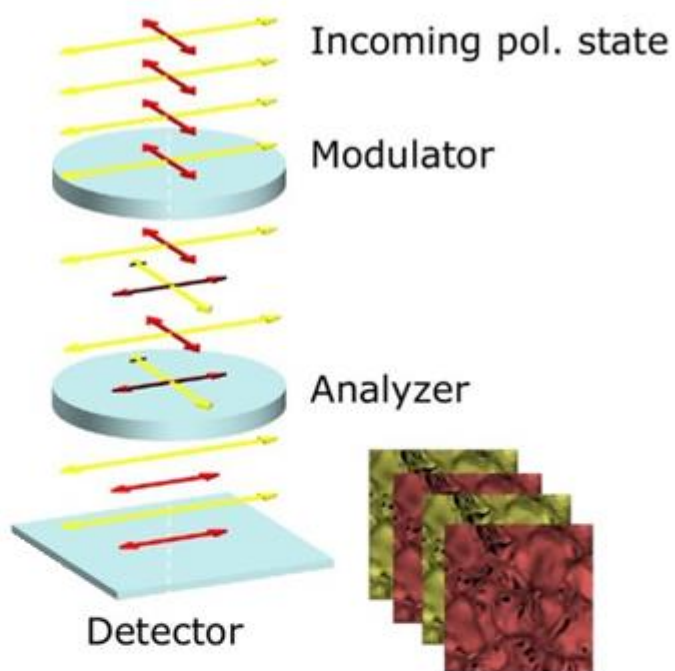

Modulation \sim 10 kHz
 Frame-Rate \sim 400 Hz

Intensity = + =

Polarization = - =

● DEPFET

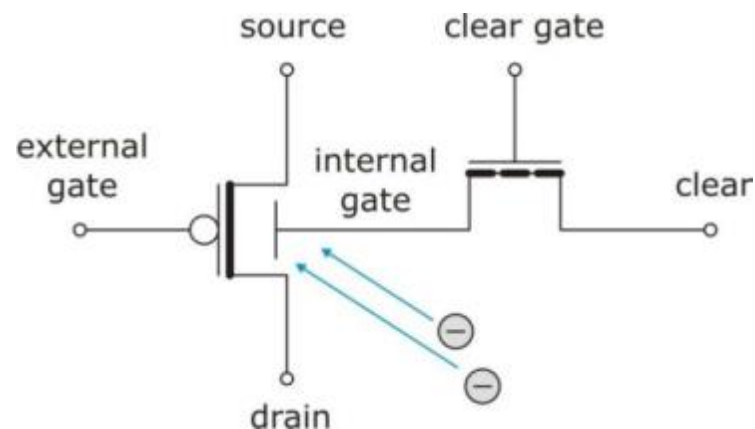
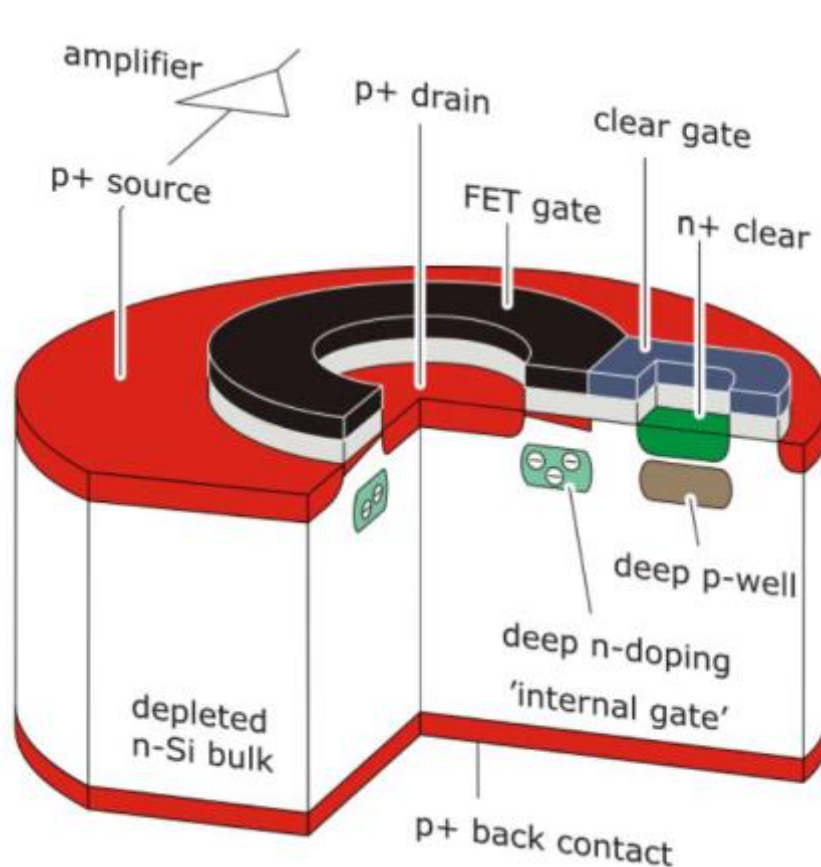

- intrinsic amplification
- low noise
- backside illumination
- 100% fill-factor

● DEPFET

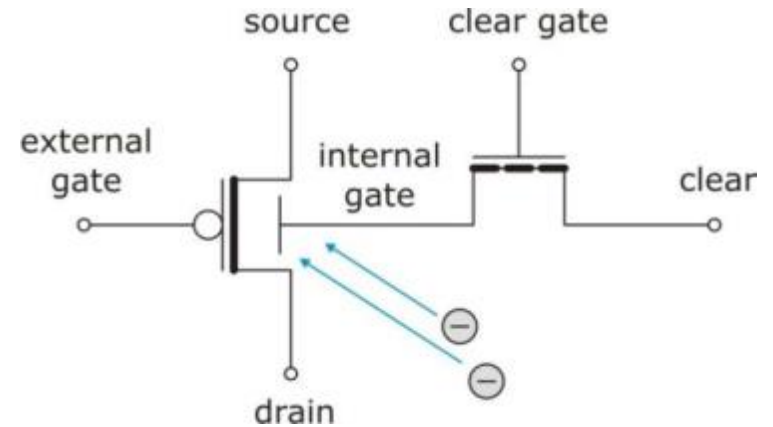
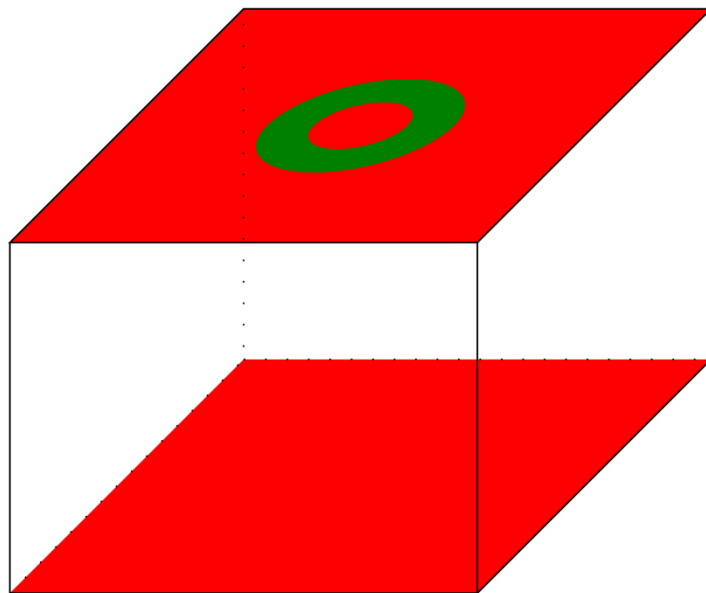

- intrinsic amplification
- low noise
- backside illumination
- 100% fill-factor

● DEPFET

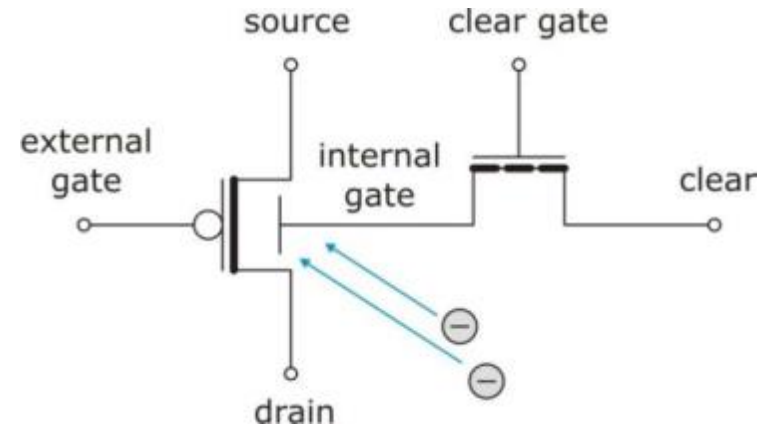
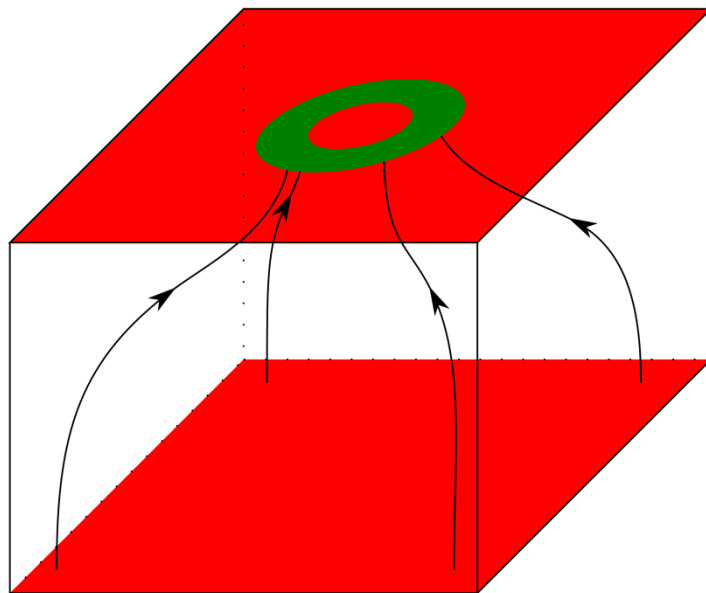

intrinsic amplification
 low noise
 backside illumination
 100% fill-factor

● Quadropix

four storage areas
fast modulation

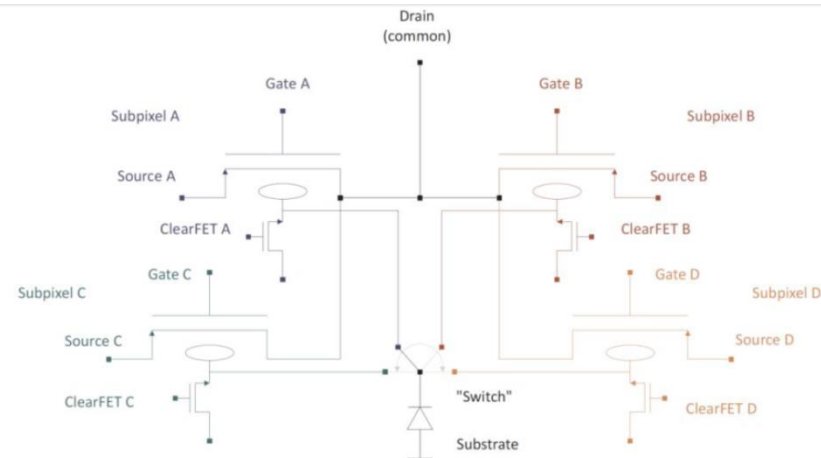
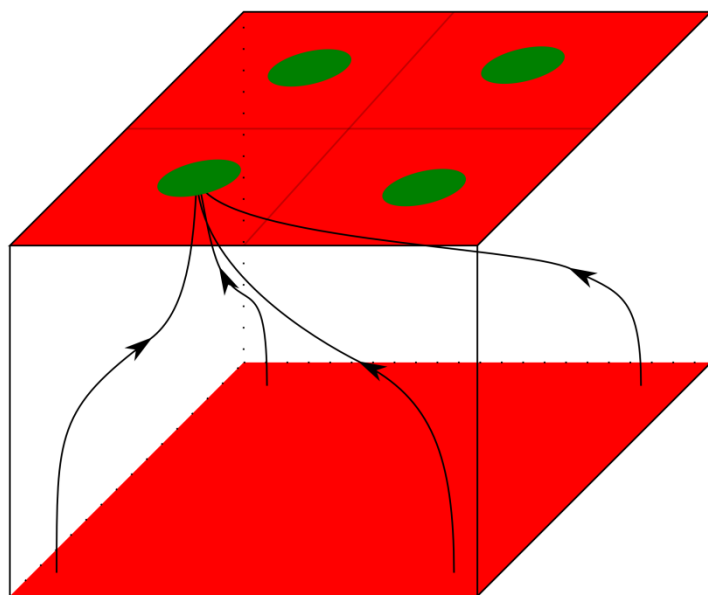

● Quadropix

four storage areas
fast modulation

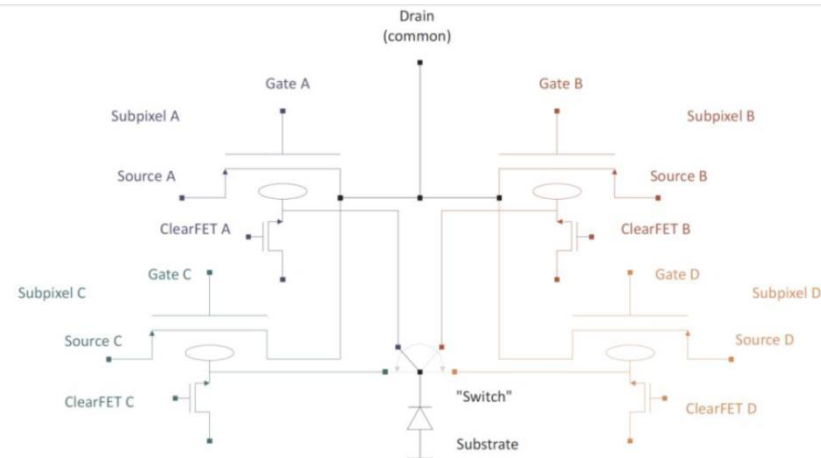
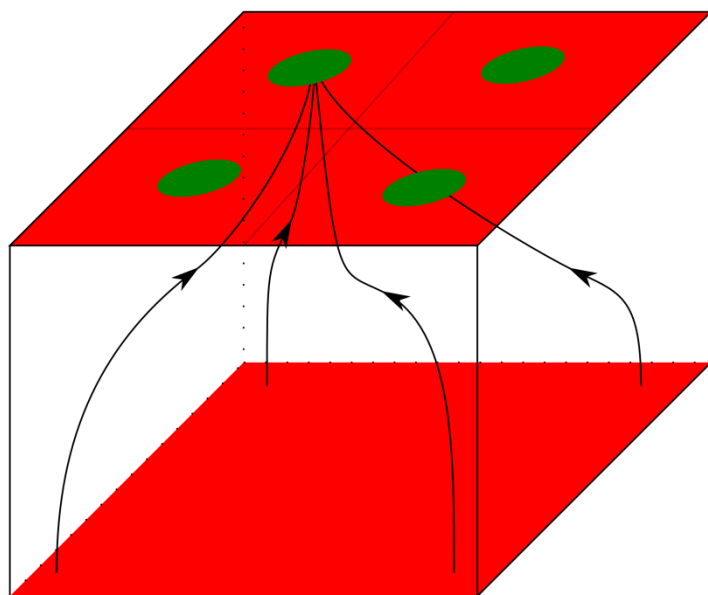

● Quadropix

four storage areas
fast modulation

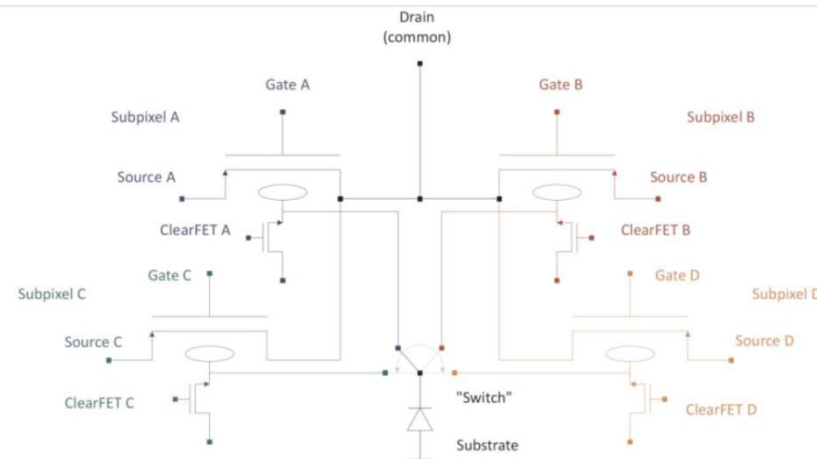
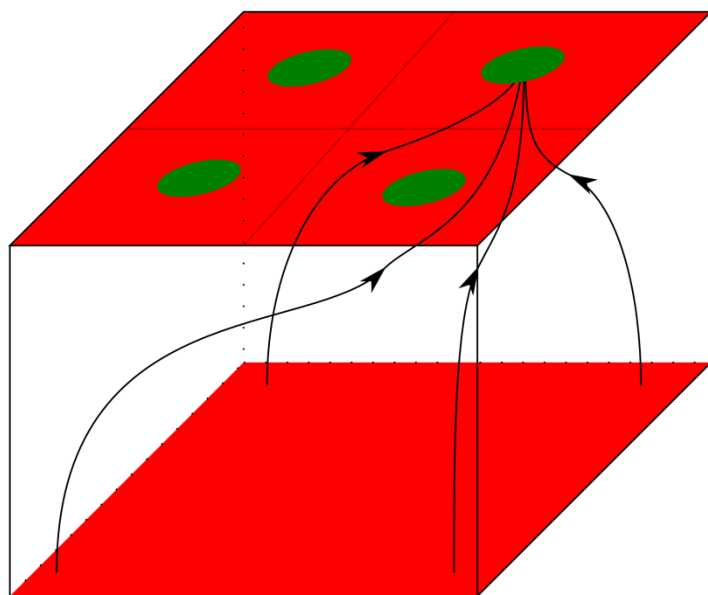

● Quadropix

four storage areas
fast modulation

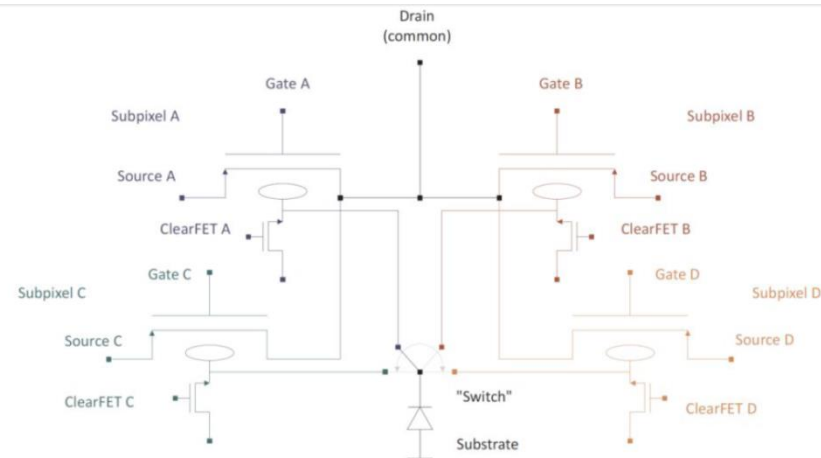
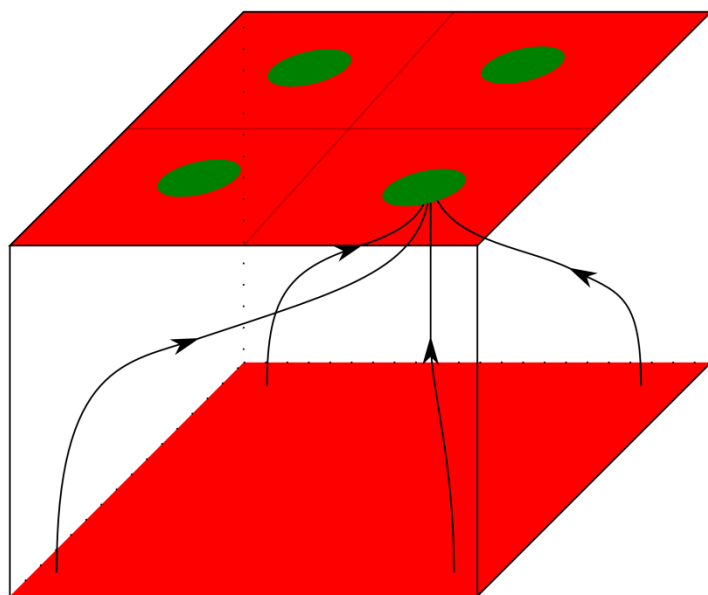

- Quadropix

four storage areas
fast modulation

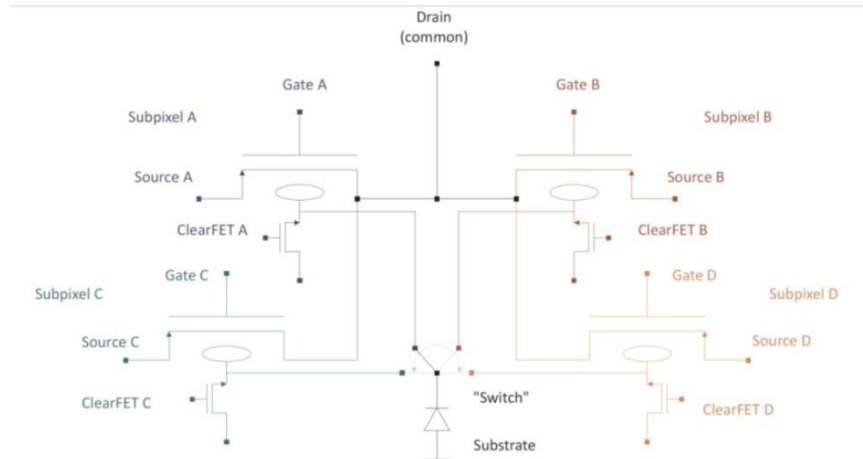
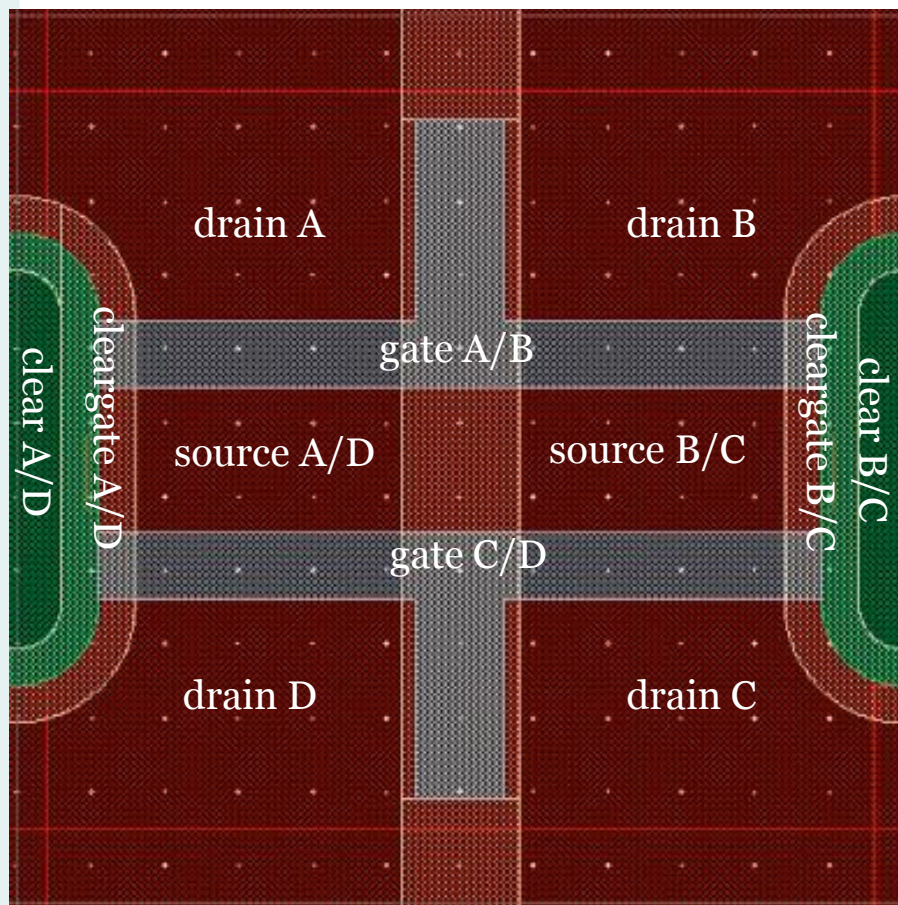

● TCAD simulations

four storage areas
fast modulation

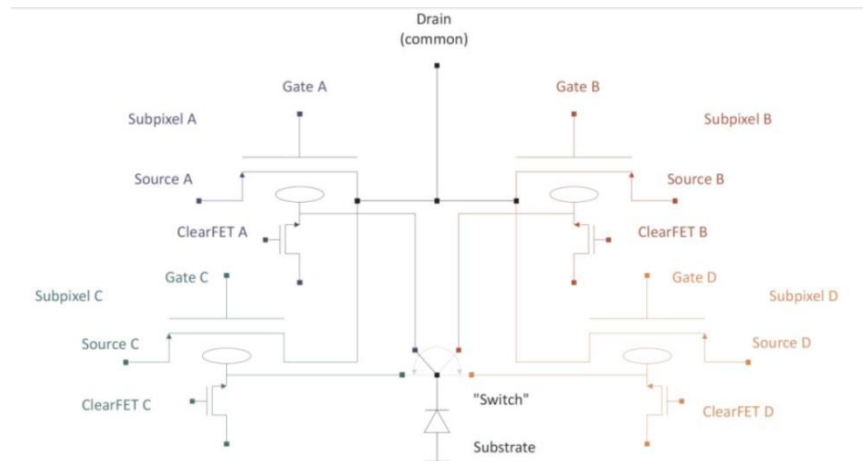
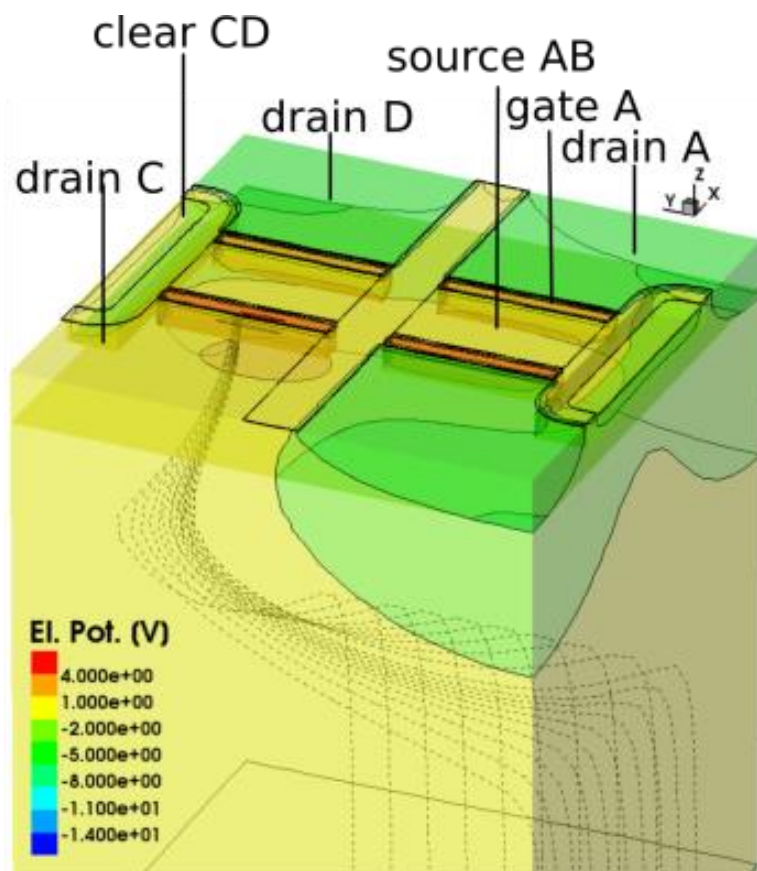

standard: limited operation window
asymmetric charge collection
-> considerable polarimetric crosstalk

optimized devices: larger operation window
-> reduced polarimetric crosstalk

thinned devices: minimized polarimetric crosstalk

for details see: Bähr et al „Advanced DePFET concepts: Quadropix“
<https://doi.org/10.1016/j.nima.2017.10.048>

- Prototype Sensor

production of first batch finished

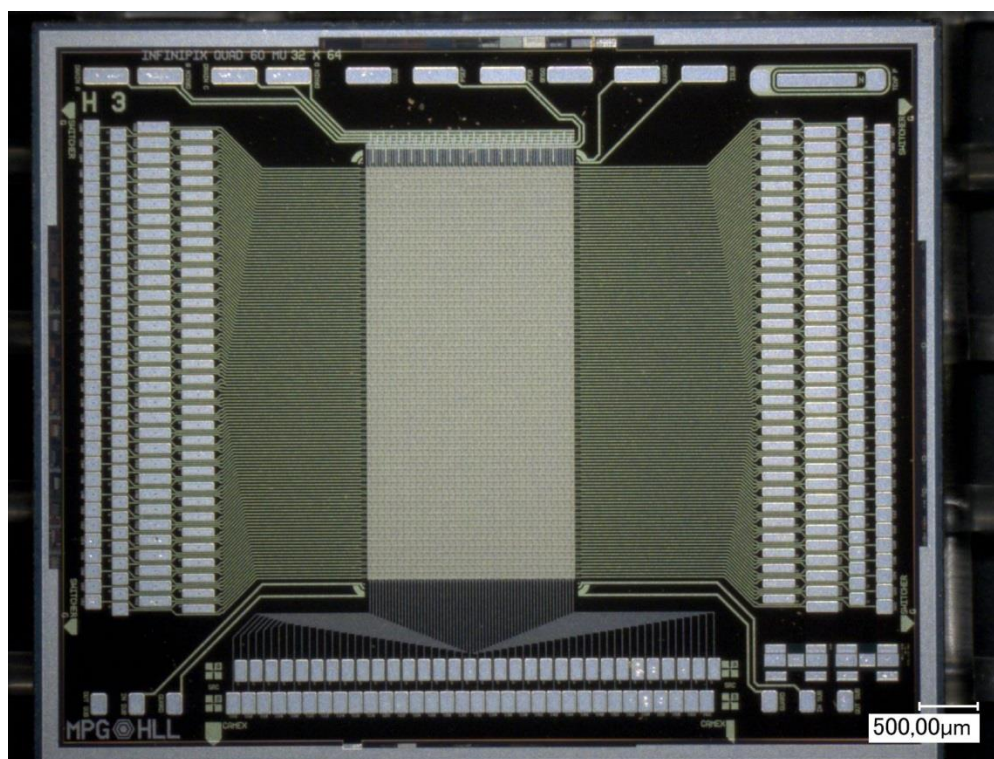

Test Sensor: 64 x 32 Quadropixel
 60 x 60 μm^2 pixel size
 450 μm bulk

- Measurement Setup

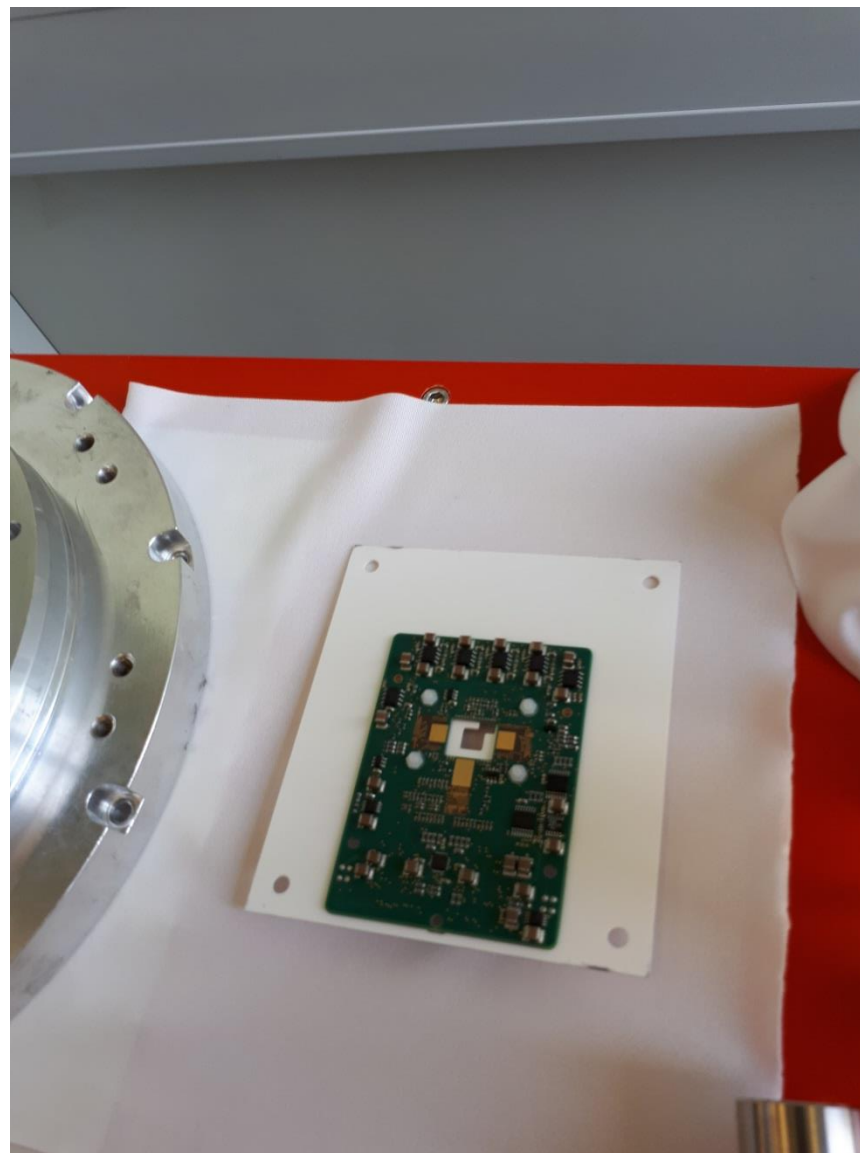

- Measurement Setup

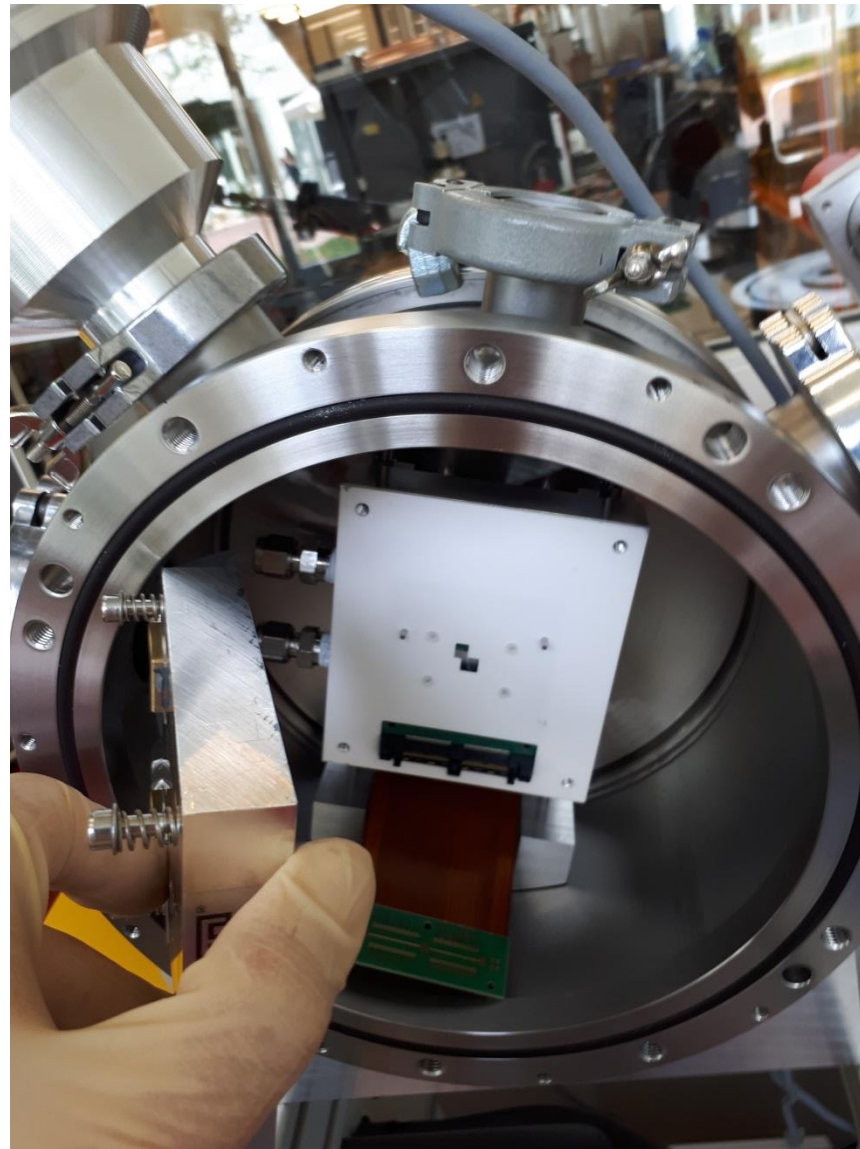

- Measurement Setup

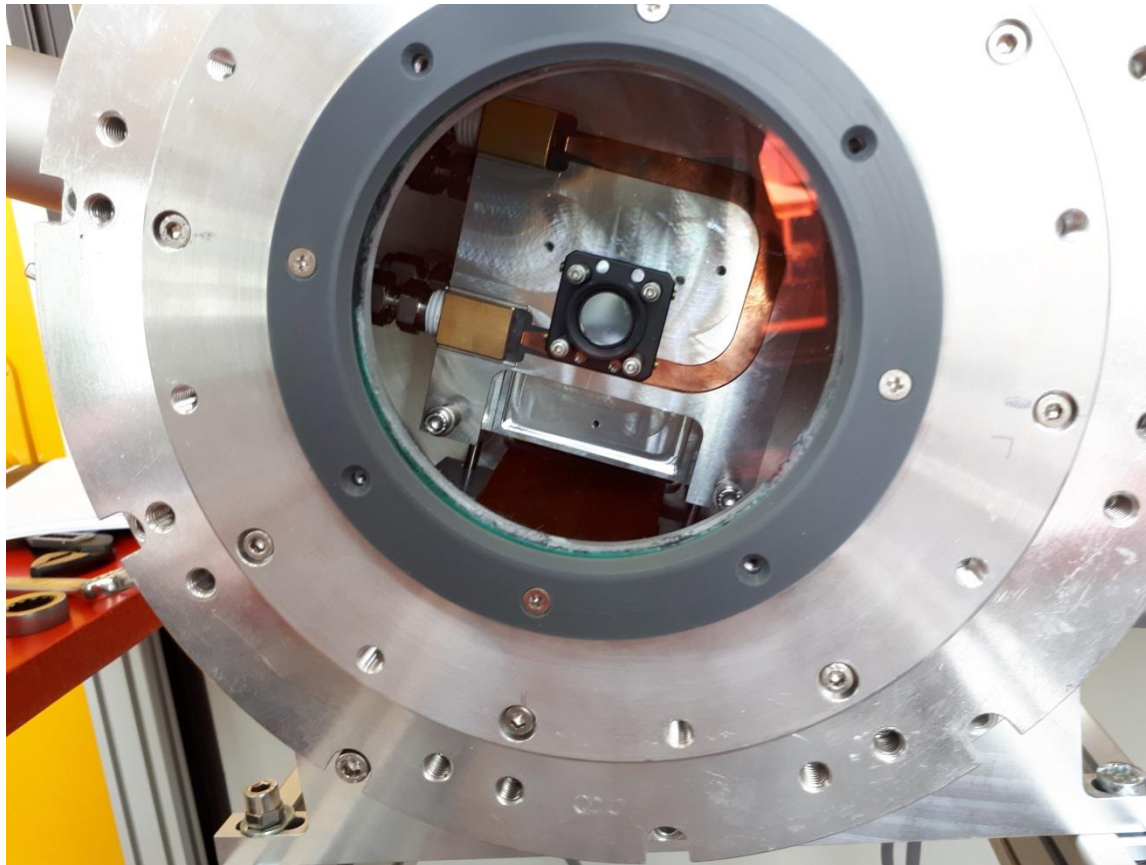

- Measurement Setup

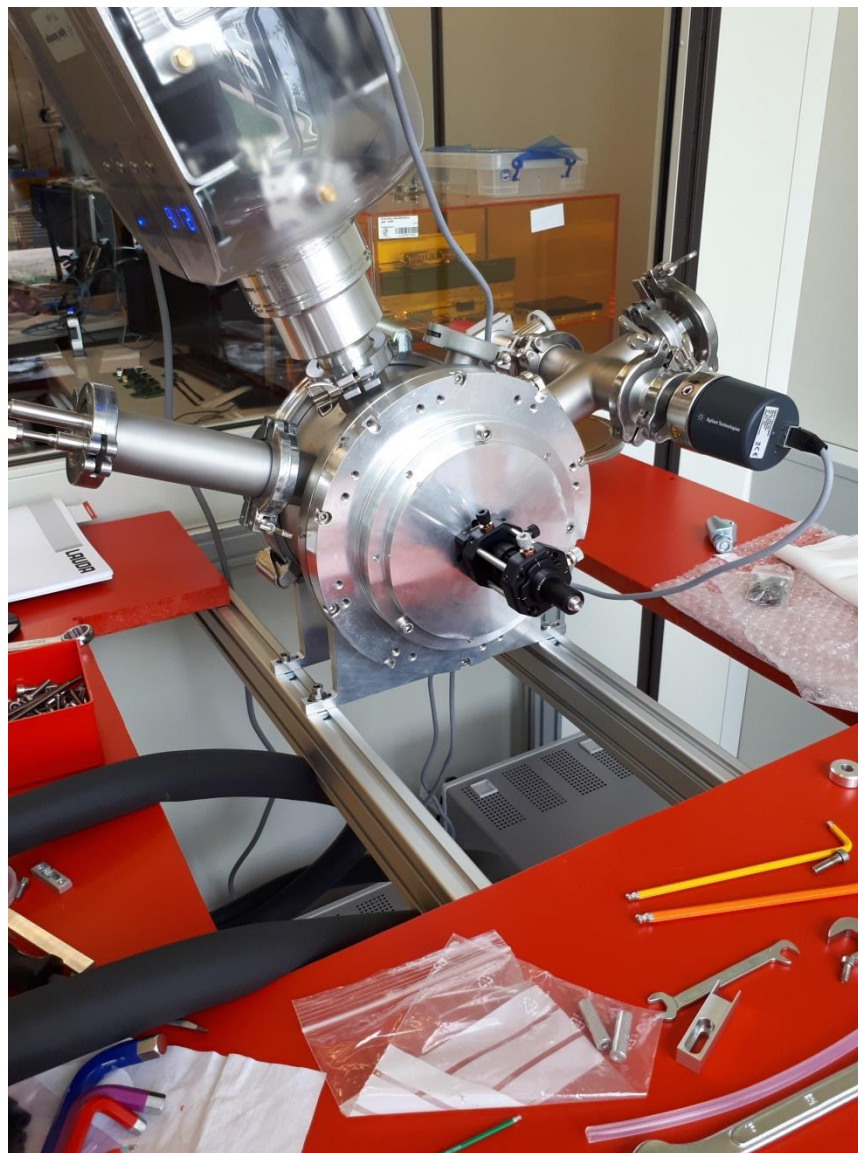

- Measurement Setup

Measurement setup (HLL / MPS)

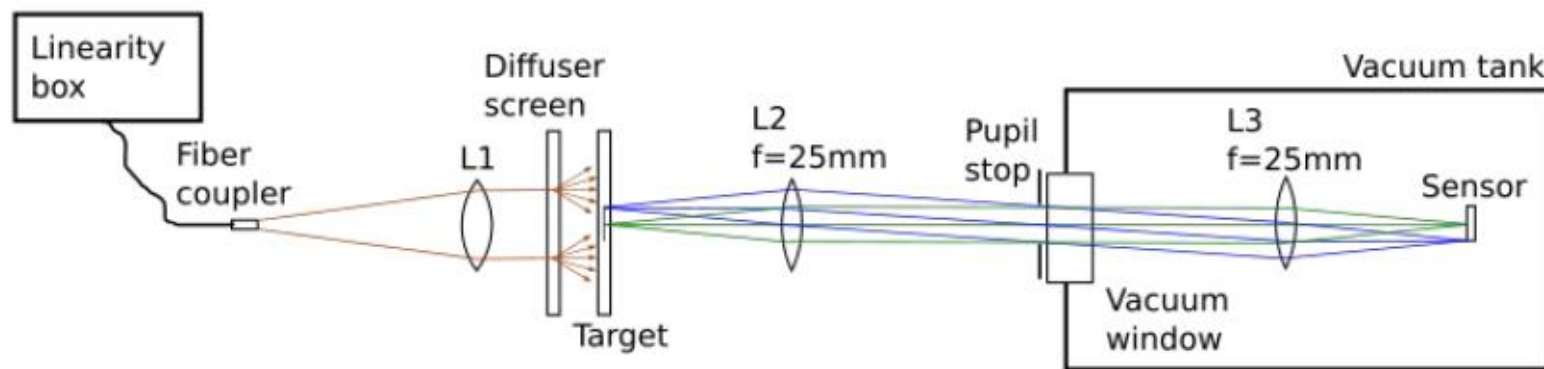

- Quadropix

four storage areas
fast modulation

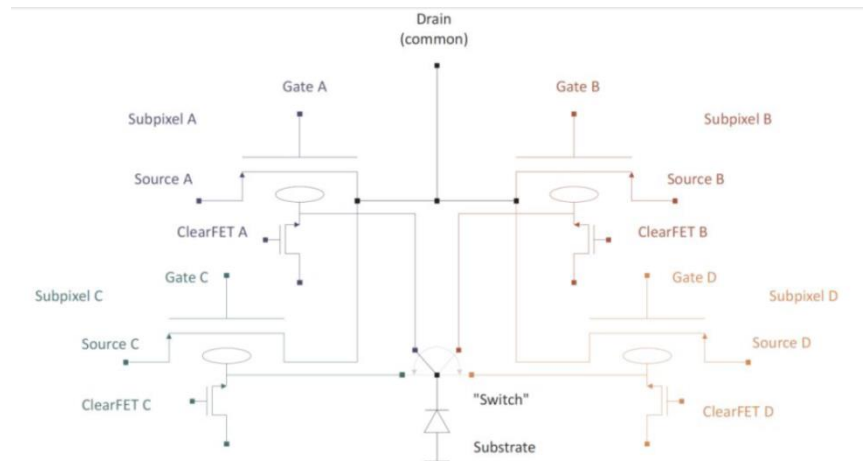
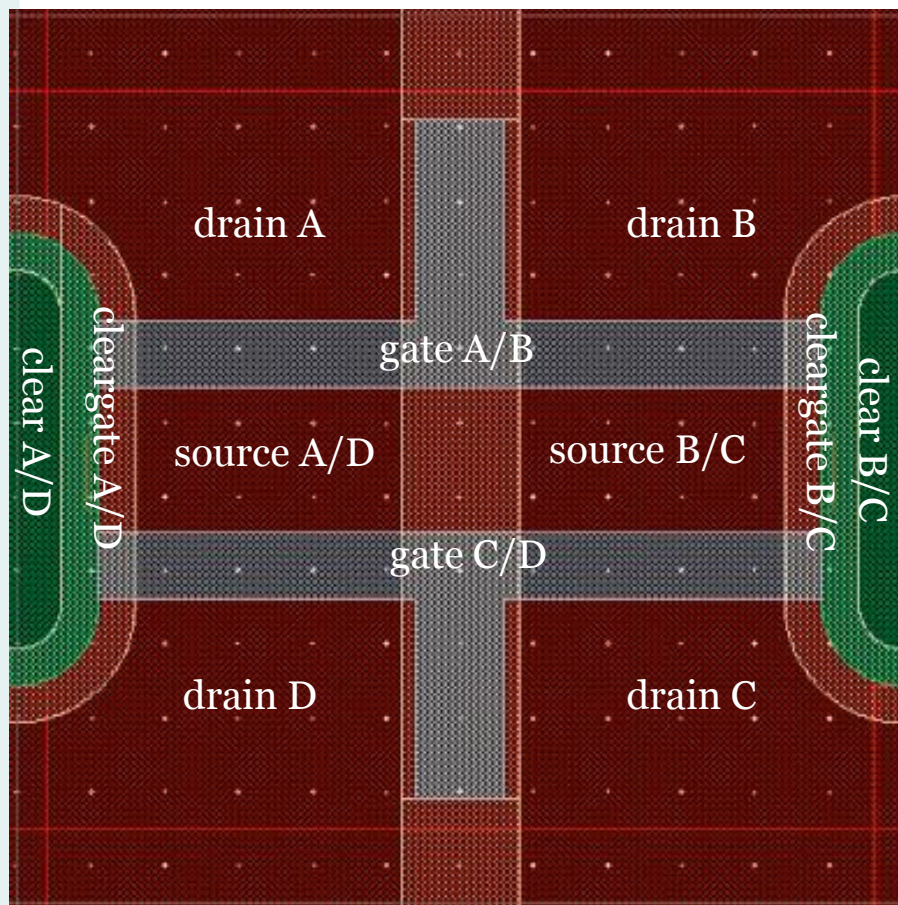

● Test Sequence

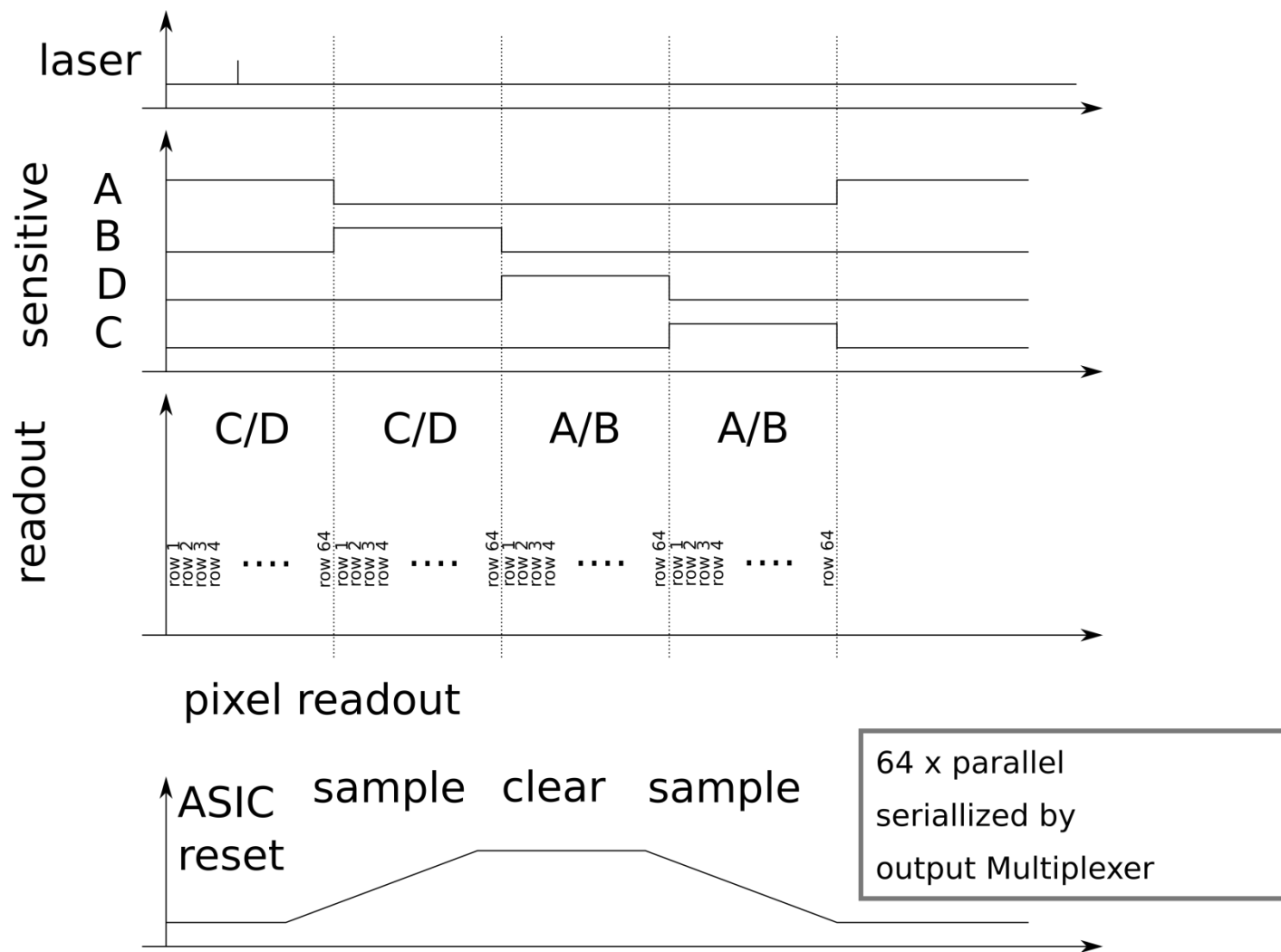

- Target Measurement

injection while A collects

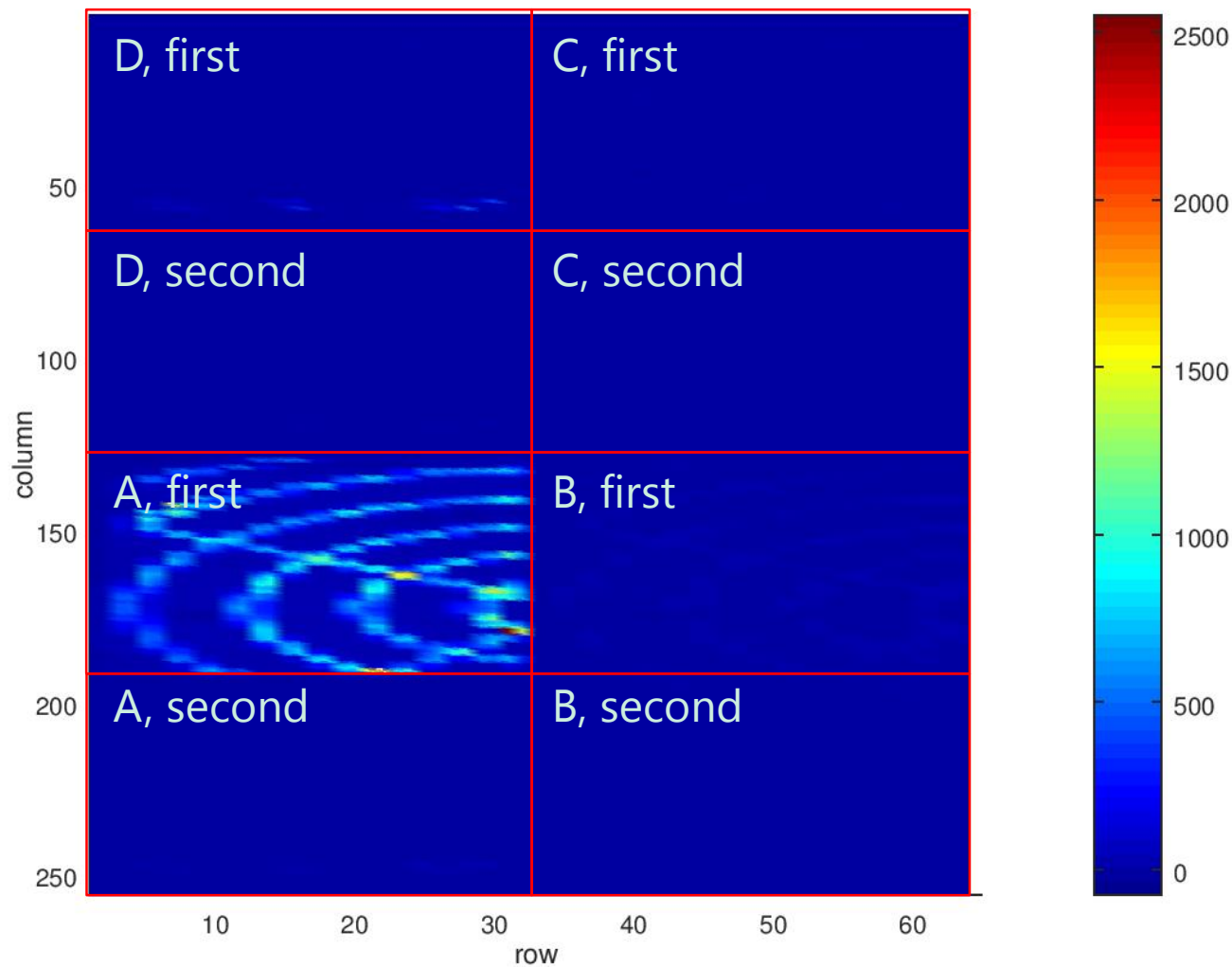

- Target Measurement

injection while B collects

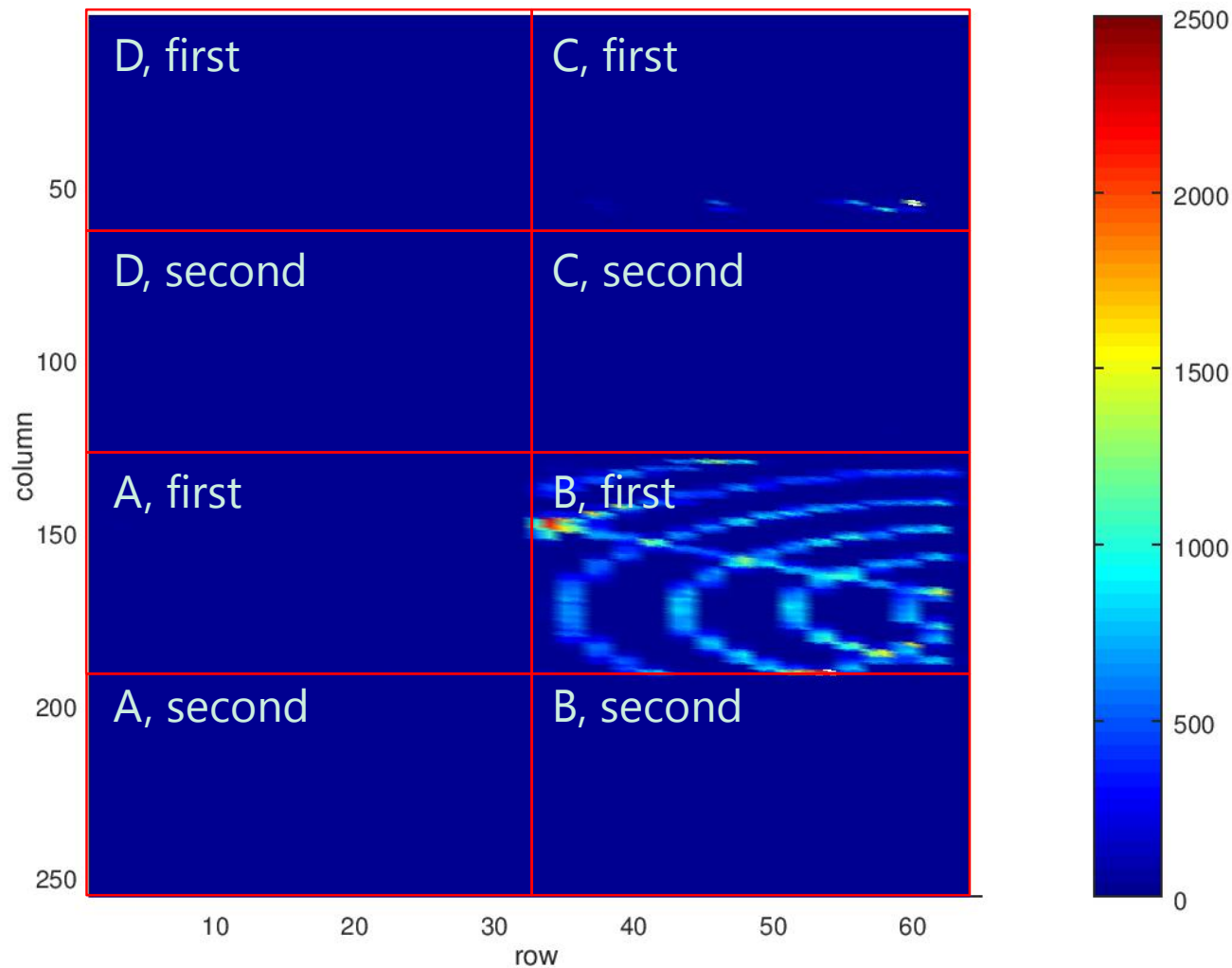

- Target Measurement

injection while C collects

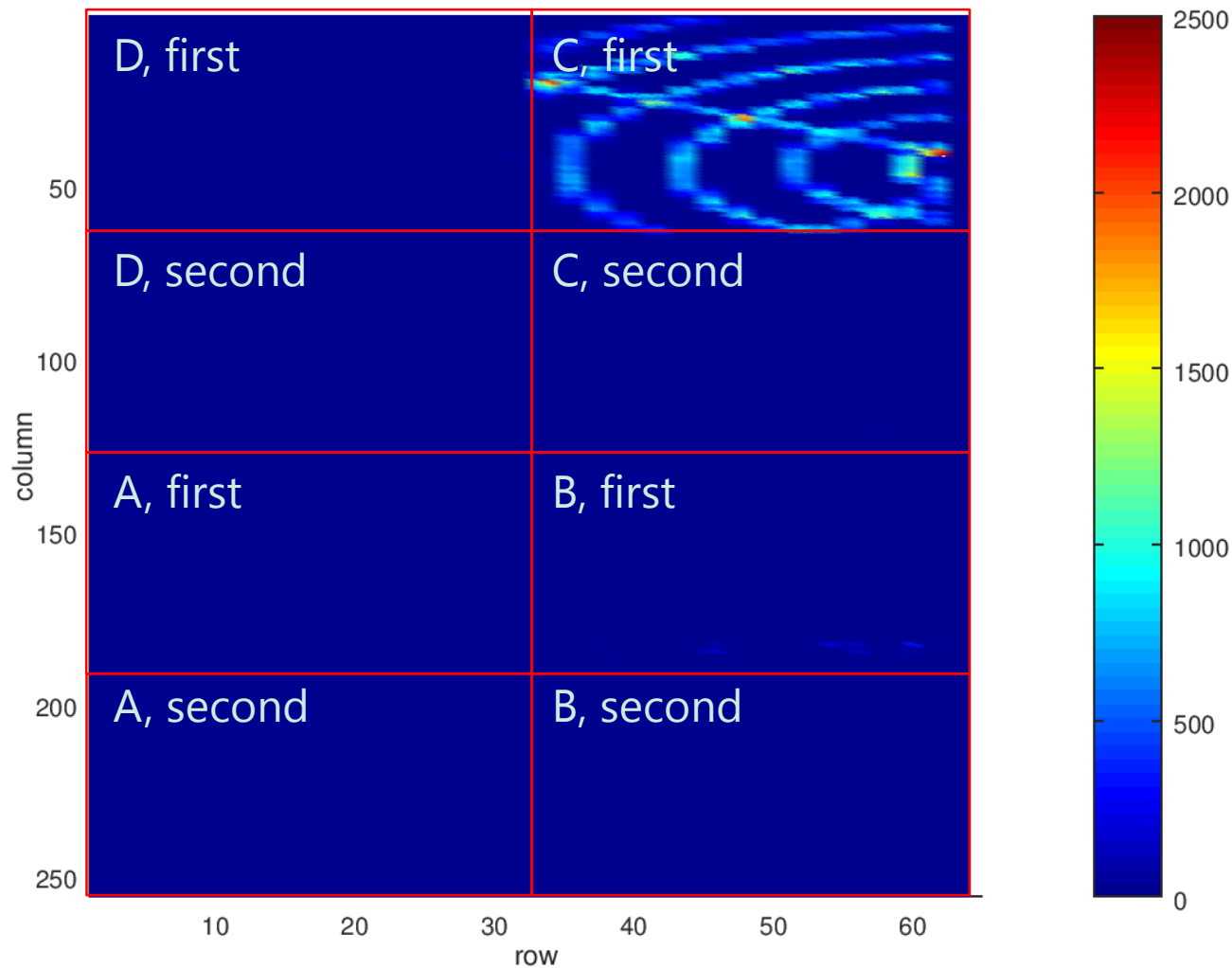

- Target Measurement

injection while D collects

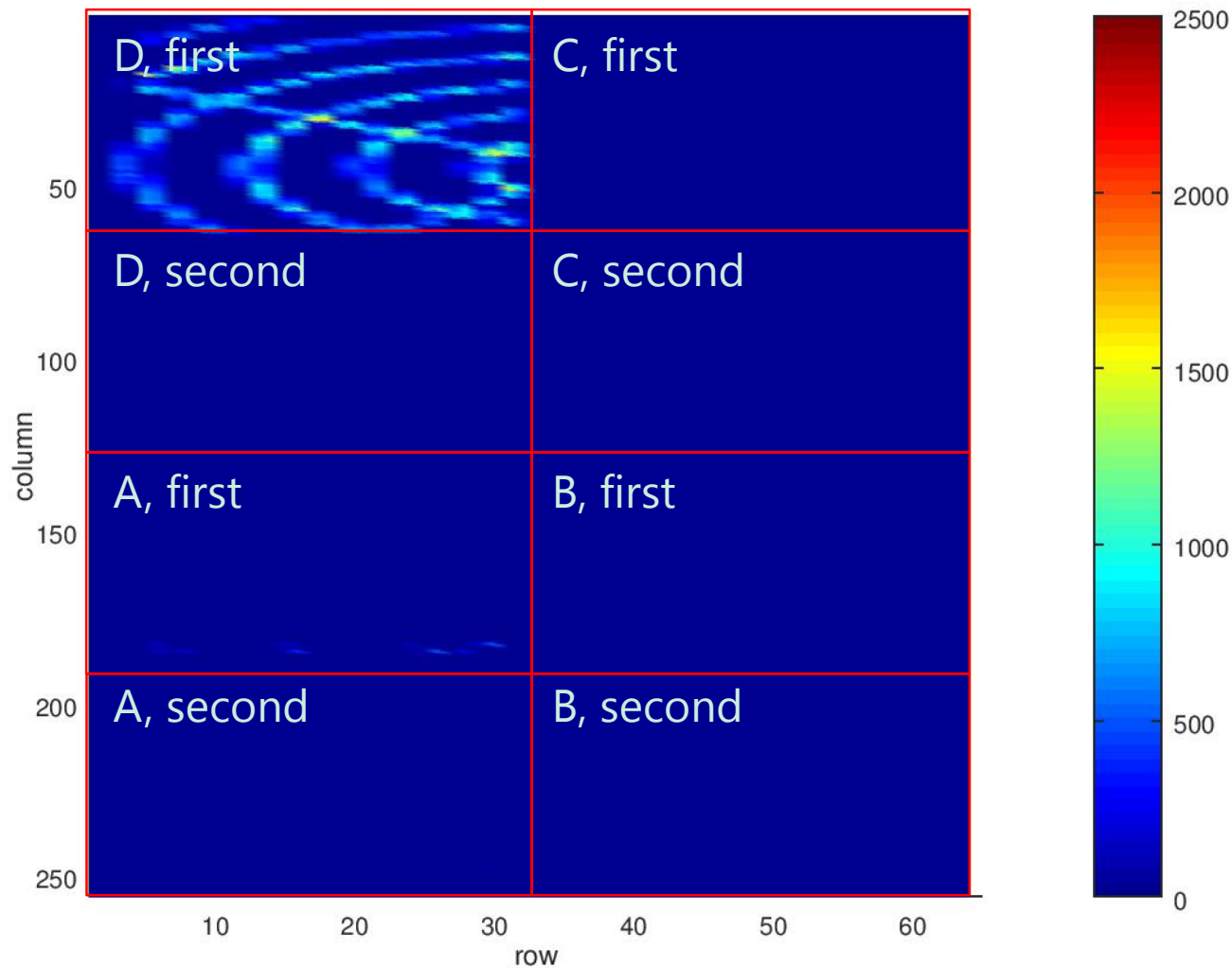

- Target Measurement

injection while A collects

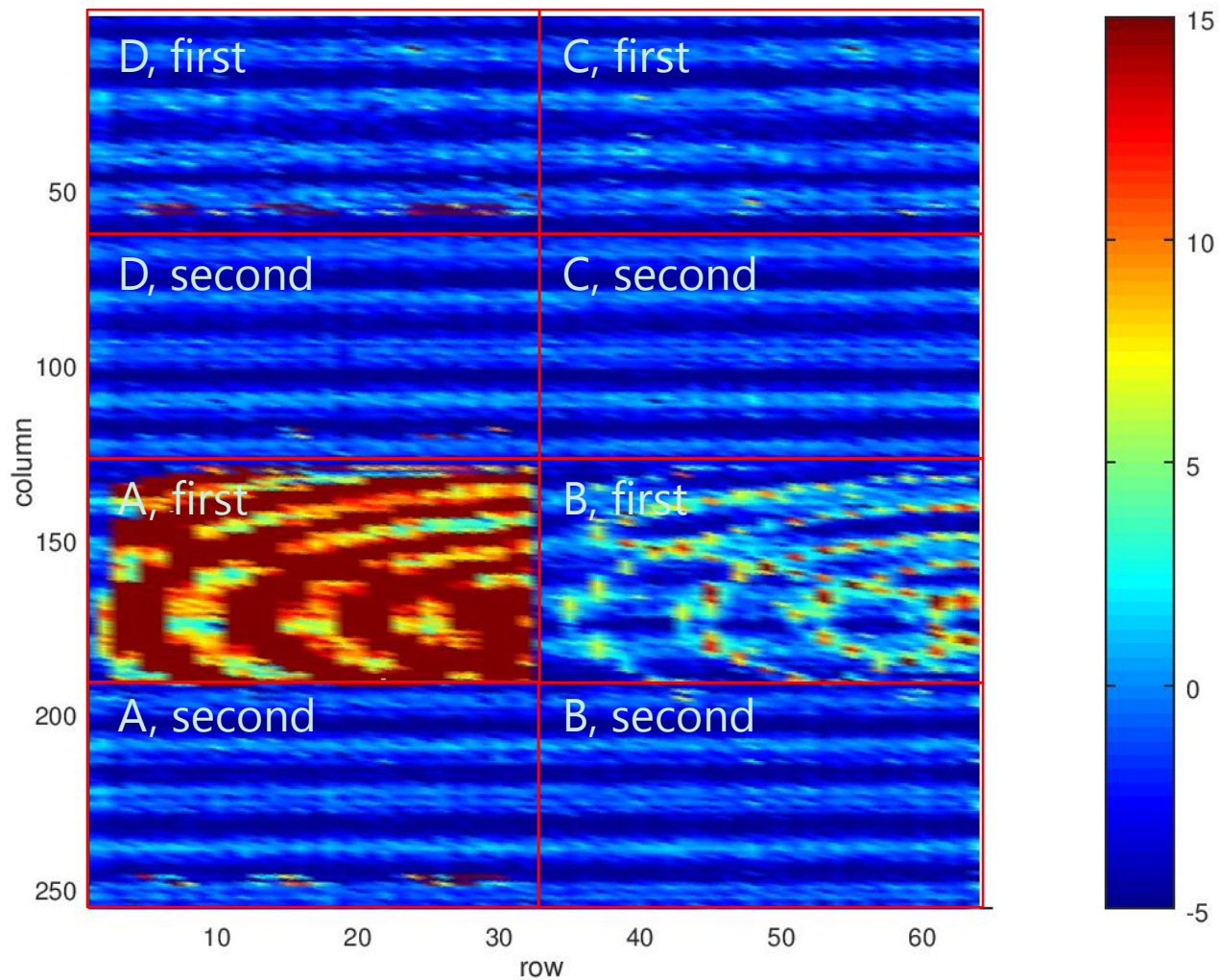

- Target Measurement

injection while B collects

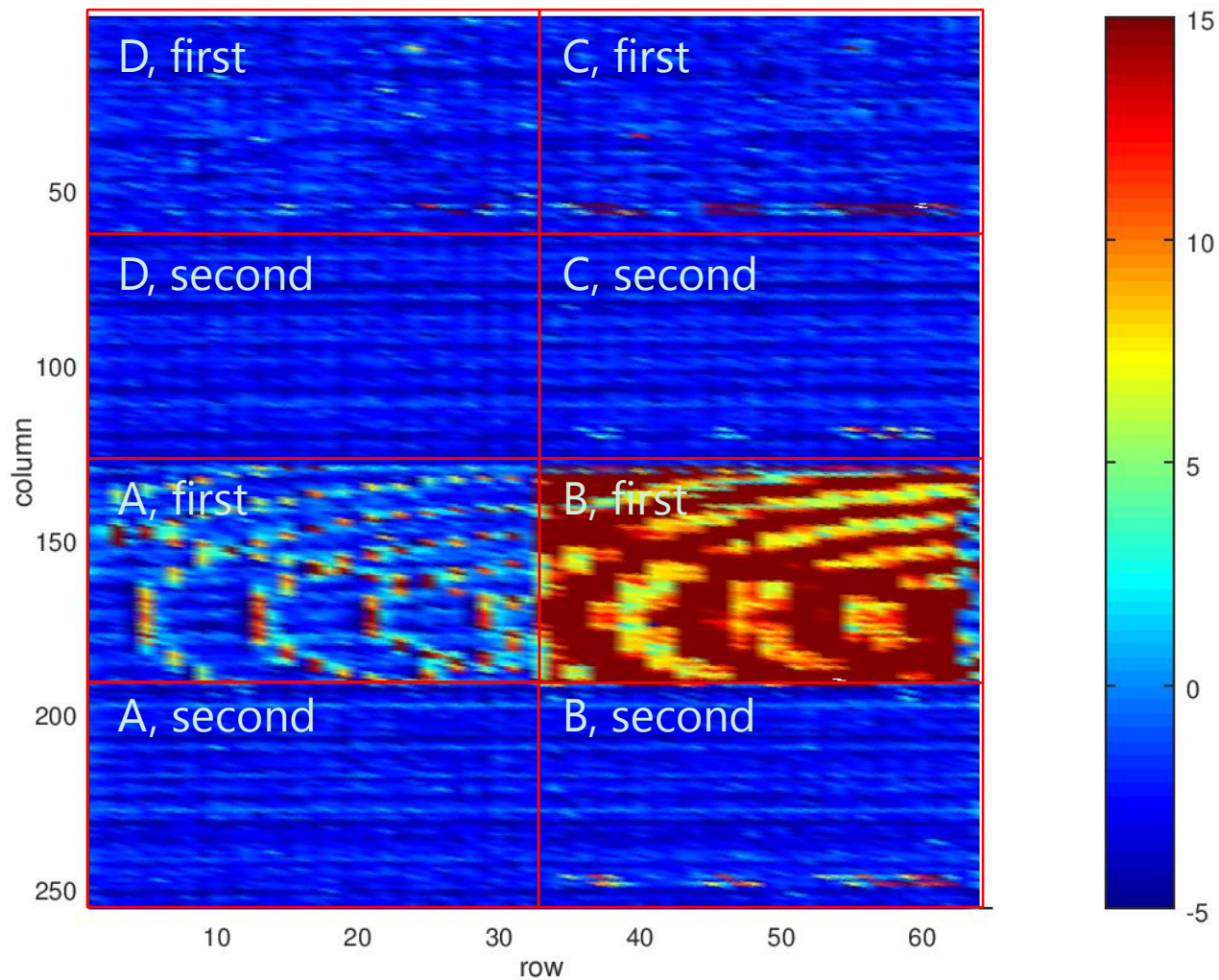

- Target Measurement

injection while C collects

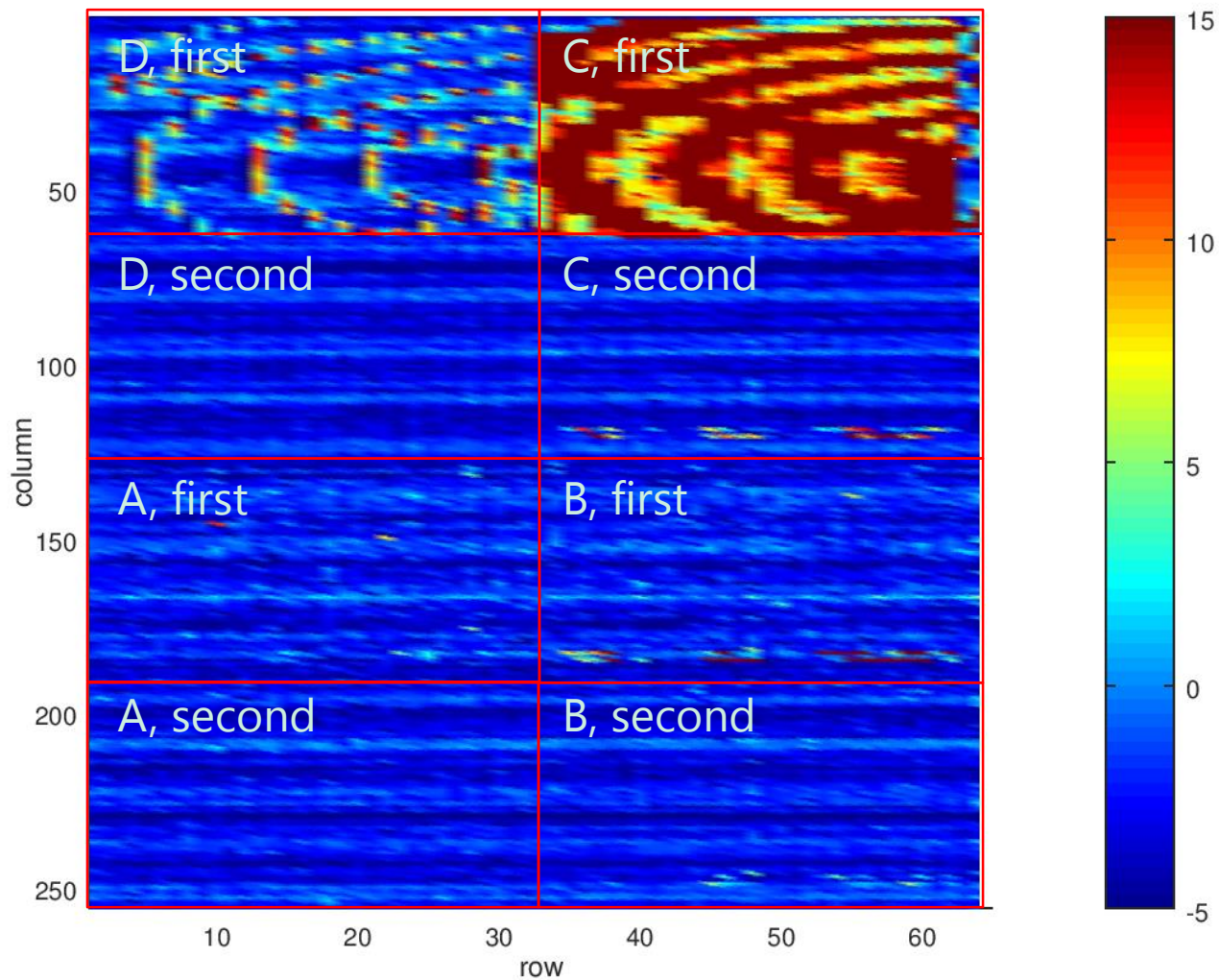

- Target Measurement

injection while D collects

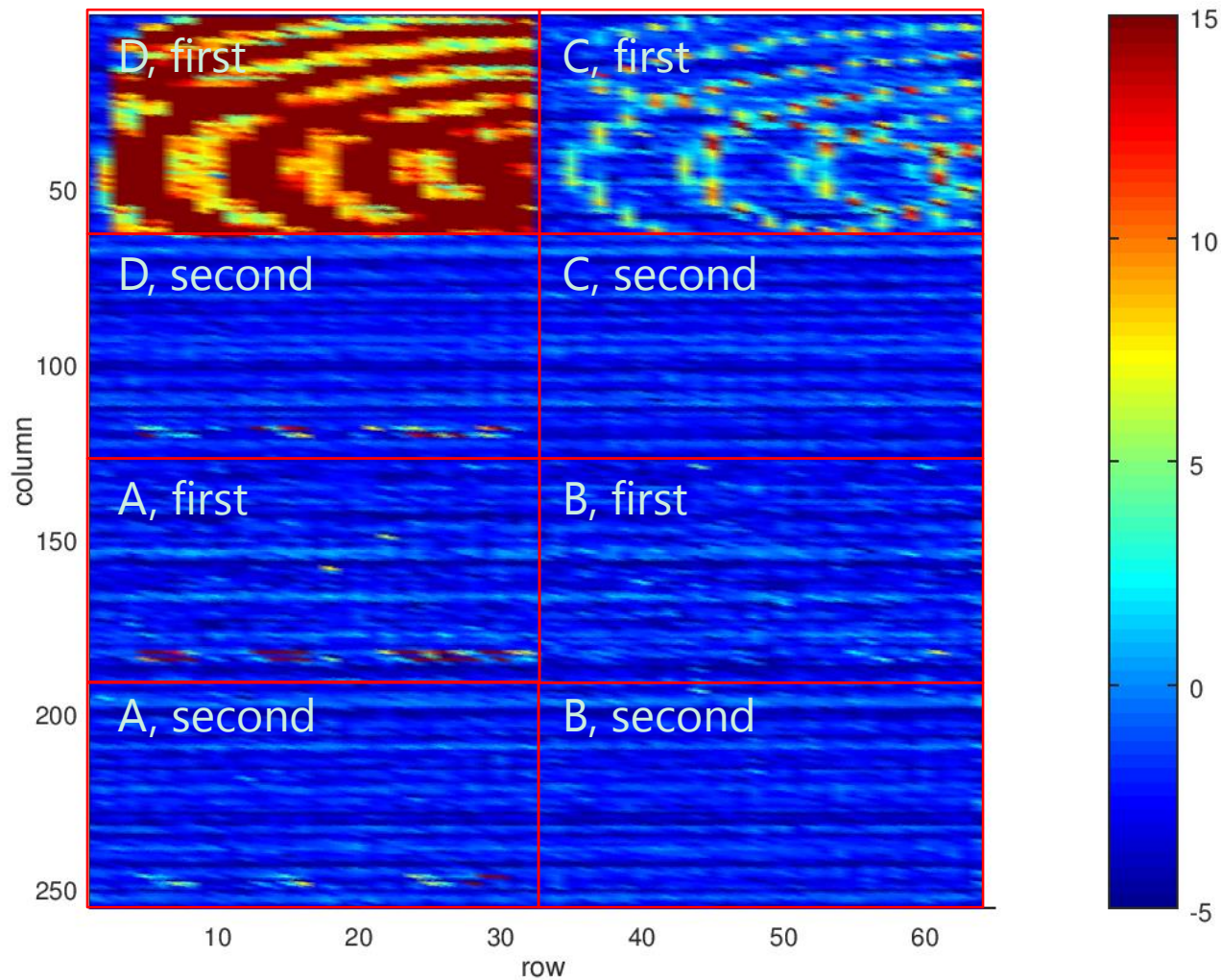

● ^{55}Fe Spectrum

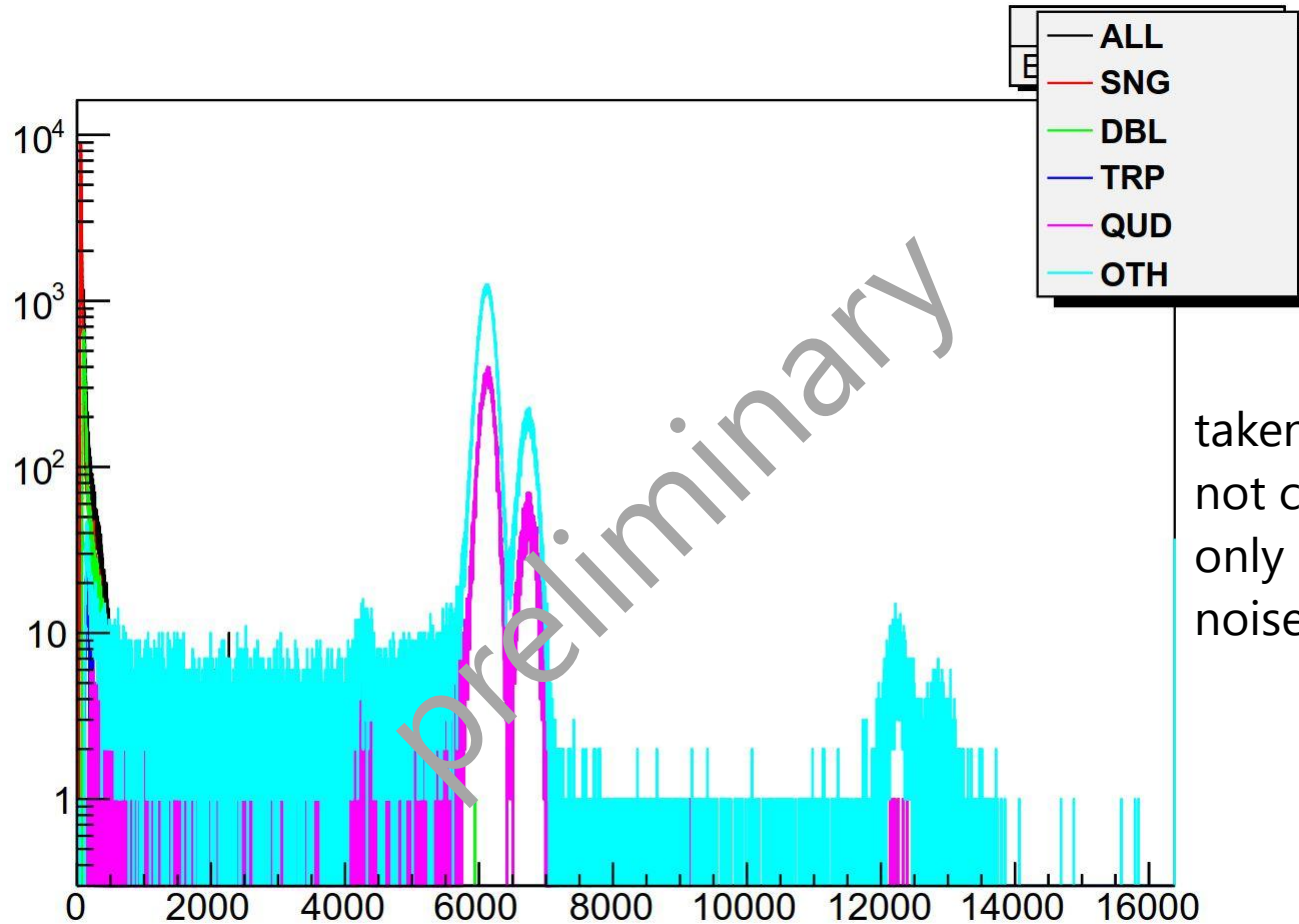

taken at -37°C
not calibrated
only multiple pixel events
noise $\sim 3-4 e^-$

● Conclusion

- Quadropix concept developed at HLL (for use at EST)
- concept functional (parameter optimization ongoing)
- optimization of geometry already investigated by simulations
-> possible

Thanks for your attention



*This project is supported by the European Commission 's H2020 Programme for the period
June 2015 – June 2018 under the Grant Agreement n° 653982*