

Accelerator Physics Exercises 1

Answers to be handed in before lecture on 26 October 2017

1. In "weak focusing" accelerators, the field gradient is defined as

$$k = -\frac{1}{(B_0\rho_0)} \frac{\partial B_z}{\partial x}$$

Show that the equation of motion of a particle in the horizontal degree of freedom is

$$\frac{1}{p_0} \frac{d}{ds} \left(p_0 \frac{dx}{ds} \right) + \left(\frac{1}{\rho^2} - k \right) x = 0$$

and in the vertical plane it is

$$\frac{1}{p_0} \frac{d}{ds} \left(p_0 \frac{dz}{ds} \right) + kz = 0$$

Vertical oscillations are stable as long as $k > 0$. Discuss the limit on k for horizontal stability.

2. A new 50 GeV (kinetic energy) proton synchrotron, the PS2 accelerator, has been considered to replace the CERN PS. The new accelerator will be situated in a new ring tunnel which has a mean radius of 215 m. and will receive an injected beam at 4 GeV (kinetic energy) from a new linear accelerator - the Superconducting Proton Linac (SPL). The 1.8 T magnetic field of the bending magnets is excited by a sine wave which oscillates between injection and top energy at a frequency of 0.3 Hz. Given that the mass of the proton is 0.9383 GeV:

- a) What is the momentum at 4 GeV and at 50 GeV?
- b) What is the $(B\rho)$ at 4 GeV and at 50 GeV?
- c) What is the bending radius ρ ?
- d) What is the fraction of the ring filled with dipole magnets?

3. **(a)** A quadrupole doublet (half of the FODO cell from the mid-point of the F to the mid-point D) consists of two lenses of focal length f_1 and f_2 separated by a drift length of l m. Assume that the lenses are thin and show, by writing the three matrices for the lenses, that the product matrix is:

$$M = \begin{pmatrix} 1 - l/f_1 & l \\ -1/f^* & 1 - l/f_2 \end{pmatrix}$$

where

$$\frac{1}{f^*} = \frac{1}{f_1} + \frac{1}{f_2} - \frac{l}{f_1 f_2}$$

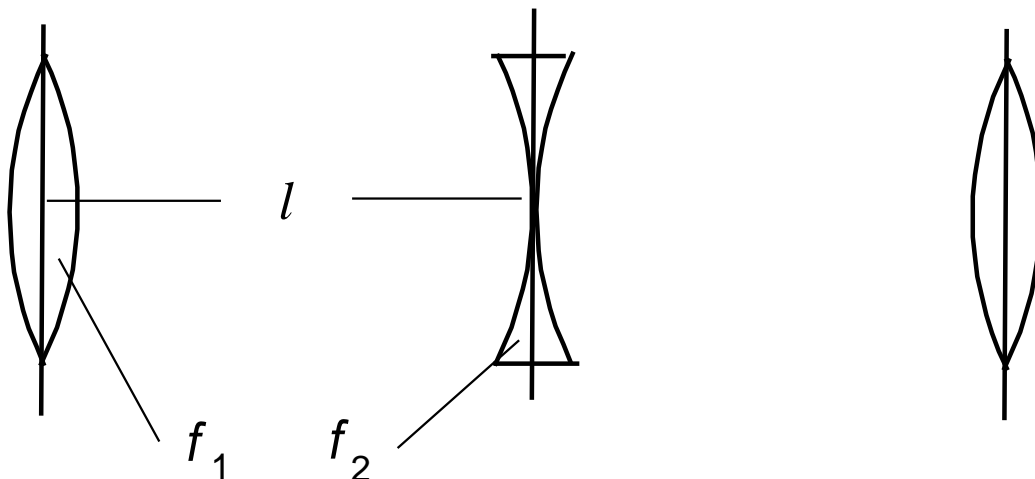

(b) A FODO cell (from mid-point of F through D and to the mid-point of the next F) may be considered to be one such matrix with $f_1 = +2f$ and $f_2 = -2f$ followed (and multiplied) by another matrix with $f_1 = -2f$ and $f_2 = +2f$. Using the result of Question 4a, write down these two matrices and show by taking their product that the matrix for a FODO cell from mid-F to mid-F quadrupoles is

$$= \begin{pmatrix} 1 - l^2/2f^2 & 2l(1 + l/2f) \\ -l/2f^2(1 - l/2f) & 1 - l^2/2f^2 \end{pmatrix}$$

(c) The matrix for a FODO period must have the form:

$$M = \begin{pmatrix} \cos \mu + \alpha \sin \mu & \beta \sin \mu \\ -\gamma \sin \mu & \cos \mu - \alpha \sin \mu \end{pmatrix}$$

Take the trace of this matrix and equate it to the result of Question 4b to obtain an expression for μ , the phase advance per period, as a function of l and f .

Now equate m_{12} to find β at the mid plane of the F quadrupole.

You are given the following data for the new PS2 ring:

- $(B\rho)$ to be calculated from Question 2b.
- Quadrupole half-length $(lq/2) = (1.49/2)$ m.
- Quadrupole gradient = 17 T/m
- Distance between quadrupole centres = 11.605 m.

Substitute the data to obtain the numerical value of μ and β .

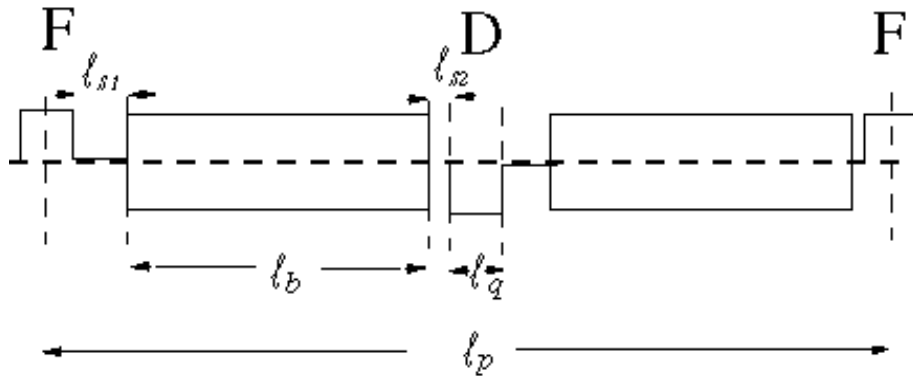

4) The emittance of a proton beam at injection in the CERN SPS is found to be 2 mm mrad.

- Calculate the half-width of the beam at an F quadrupole where $\beta = 108$ m.
- What is the maximum value of the divergence in the beam if the β at a D quadrupole is 18 m. and $\alpha = 0$?
- What is the normalised emittance of this beam if the above data refer to a proton momentum of 10 GeV/c?
- If this normalised emittance is accelerated to 400 GeV/c, what will be the half-width of the beam at an F quadrupole ($\beta = 109$ m.)?