Lecture 14 - Radiofrequency Cavities I

Professor Emmanuel Tsesmelis
Principal Physicist, CERN
Department of Physics, University of Oxford

Accelerator Physics Graduate Course
John Adams Institute for Accelerator Science
15 November 2017

Table of Contents I

- Introduction
 - Linear Accelerator Structures
 - Wideröe and Alvarez Structures
 - Phase Focusing
 - Waves in Free Space
 - Conducting Surfaces
 - Waveguides
 - Rectangular and Cylindrical Waveguides
-

Introduction

DC versus RF

DC accelerator



RF accelerator



Introduction

- Necessary conditions for acceleration
- Both linear and circular accelerators use electromagnetic fields oscillating in resonant cavities to apply the accelerating force.

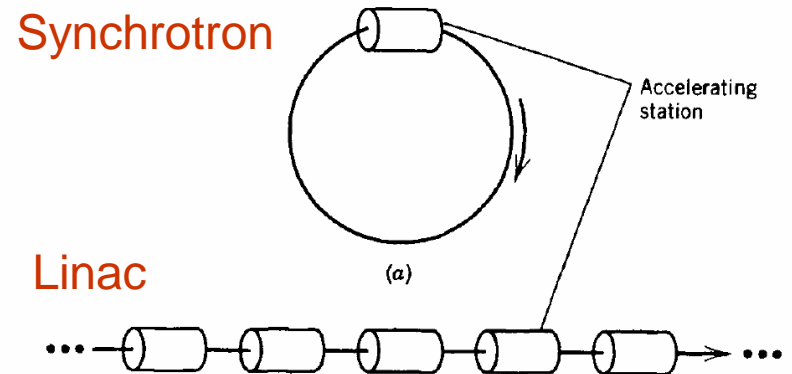

- LINAC – particles follow straight path through series of cavities
- CIRCULAR ACCELERATORS – particles follow circular path in B-field and particles return to same accelerating cavity each time around

Introduction

- ❑ Limitations to final beam energy achievable in static accelerators may be overcome by the use of high frequency voltages.
 - ❑ Virtually all modern accelerators use powerful radiofrequency (RF) systems to produce the required strong electric fields.
 - ❑ Frequencies ranging from few MHz to several GHz.
-

Introduction

- In classical linac or synchrotron, EM field oscillates in resonant cavity and particles enter and leave by holes in end walls.
 - Energy is continuously exchanged between electric and magnetic fields within cavity volume.
 - The time-varying fields ensure finite energy increment at each passage through one or a chain of cavities.
 - There is no build-up of voltage to ground.
 - Equipment which creates and applies field to the charged particles is known as RADIOFREQUENCY (RF), and much of its hardware derived from telecommunications technology.
-

Introduction – Maxwell's Equations

$$\nabla \times \mathbf{E} = - \frac{d\mathbf{B}}{dt}$$

◆ Becomes in its integral form

$$\int_G \mathbf{E} \cdot d\mathbf{s} = - \frac{\partial}{\partial t} \int_S \mathbf{B} \cdot \mathbf{n} da$$

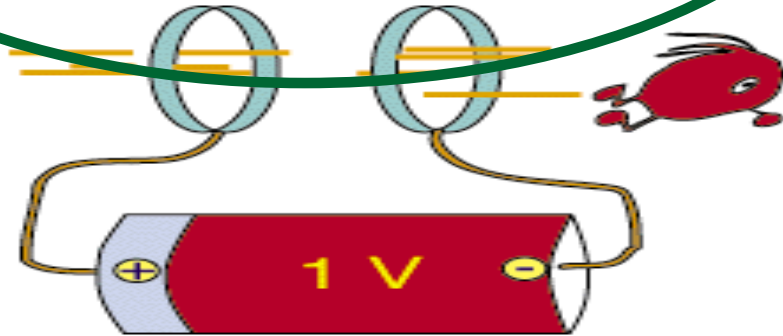

- ◆ Hence, there can be no acceleration without time-dependent magnetic field.
- ◆ We also see how time-dependent flux may provide particle acceleration.

Wideröe Linear Accelerator

- In order to avoid limitations imposed by corona formation and discharge on electrostatic accelerators, in 1925 Ising suggested using rapidly changing high frequency voltages instead of direct voltages.
- In 1928 Wideröe performed first successful test of linac based on this principle.
- Series of drift tubes arranged along beam axis and connected with alternating polarity to RF supply.
 - Supply delivers high frequency alternating voltage:

$$V(t) = V_{\max} \sin(\omega t)$$

Wideröe Linear Accelerator

- Acceleration process
 - During first half period, voltage applied to first drift tube acts to accelerate particles leaving ion source.
 - Particles reach first drift tube with velocity v_1 .
 - Particles then pass through first drift tube, which acts as a Faraday cage and shields them from external fields.
 - Direction of RF field is reversed without particles feeling any effect.
 - When they reach gap between first and second drift tubes, they again undergo an acceleration.

- Acceleration process
 - After the i -th drift tube the particles of charge q have reached energy

$$E_i = iqV_{\max} \sin \Psi_0$$

where Ψ_0 is average phase of RF voltage that particles see as they cross gaps.

Wideröe Linear Accelerator

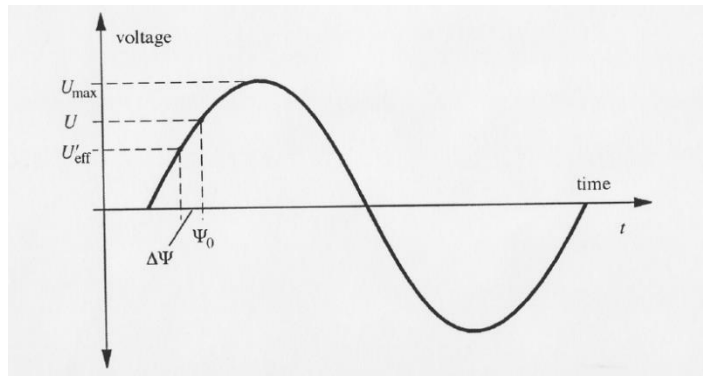
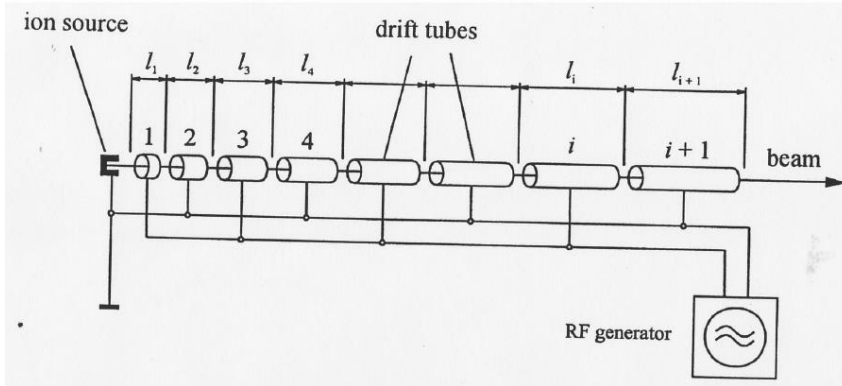

■ Observations

- Energy is proportional to number of stages i traversed by particle.
- The largest voltage in entire system is never greater than V_{max}
 - Arbitrary high energies without voltage discharge

Wideröe Linear Accelerator

- Accelerating gaps
 - During acceleration particle velocity increases monotonically but alternating voltage remains constant in order to keep the costs of already expensive RF power supplies reasonable.
 - → Gaps between drift tubes must increase.
- RF voltage moves through exactly half a period $\tau_{RF}/2$ as particle travels through one drift section.
- Fixes distance between i -th and $(i+1)$ -th gaps

$$l_i = \frac{v_i \tau_{RF}}{2} = \frac{v_i}{2f_{RF}} = \frac{v_i \lambda_{RF}}{2c} = \beta_i \frac{\lambda_{RF}}{2} = \frac{1}{f_{RF}} \sqrt{\frac{iqV_{\max} \sin \Psi_0}{2m}}$$

Modern Linear Accelerators

- Drift tubes typically no longer used and have been generally replaced by cavity structures.
 - Electron linacs
 - By energies of a few MeV, particles have already reached velocities close to light speed.
 - As they are accelerated electron mass increases with velocity remaining almost constant
 - Allows cavity structures of same size to be situated along whole length of linac.
 - Leading to relatively simple design.
-

Modern Linear Accelerators

■ Hadrons

- Particles still have non-relativistic velocities in first few stages and Wideröe-type structure is needed
 - Alvarez structure
 - Drift tubes are today arranged in a tank, made of good conductor (Cu), in which a cavity wave is induced.
 - The drift tubes, which have no field inside them, also contain the magnets to focus the beam.
 - Energy gain from accelerating potential differences between end of drift tubes, but the phase shift between drift tube gaps is 360° .
 - Alternate tubes need not be earthed and each gap appears to the particle to have identical field gradient which accelerates particle from left to right.
-

Alvarez Structure

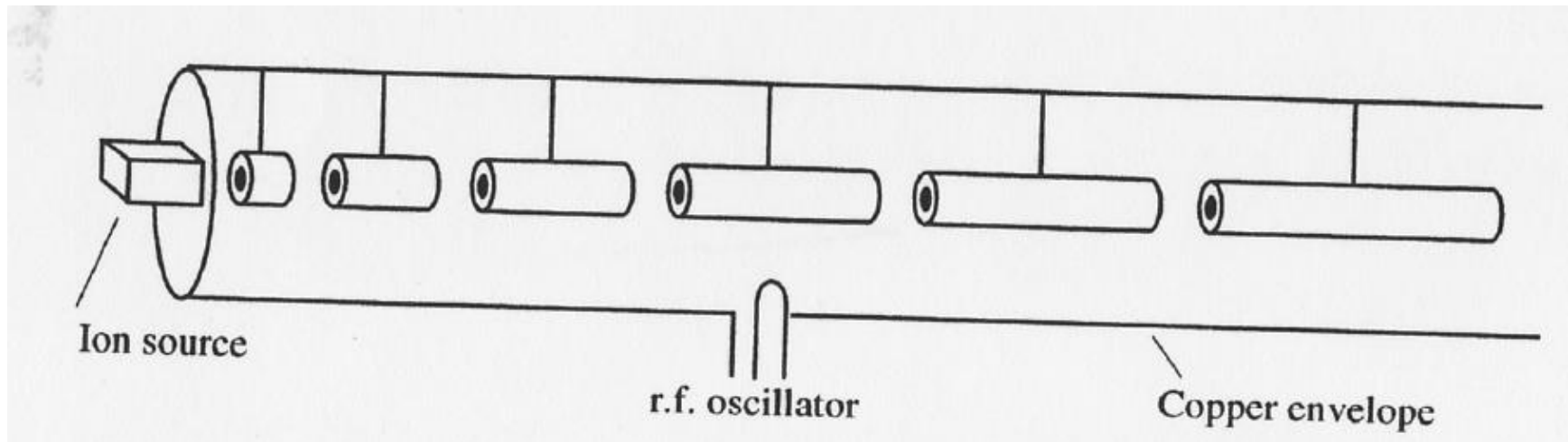

The concept of the Alvarez linear accelerator

Drift Tube Linac: Higher Integrated Field

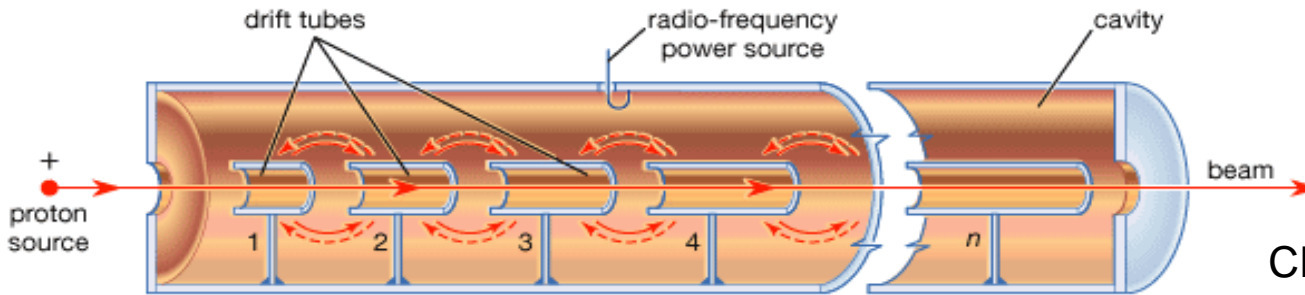

CERN LINAC1 1982-1992

© 2007 Encyclopædia Britannica, Inc.

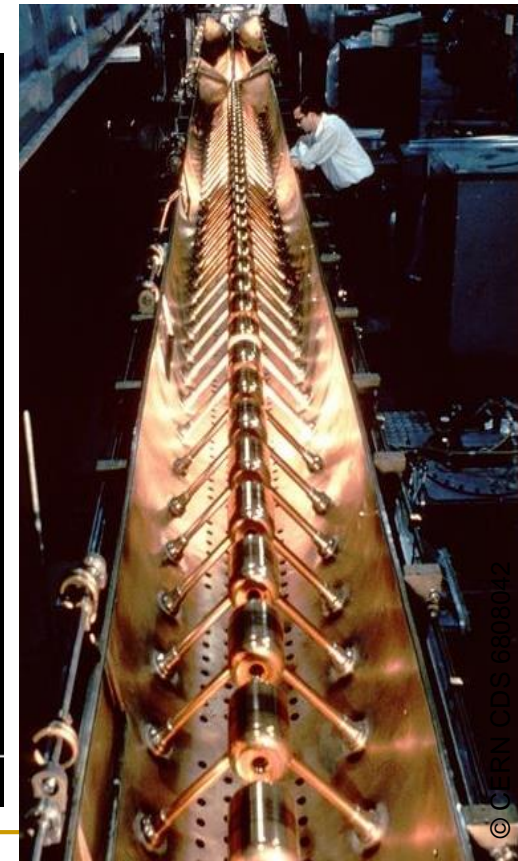
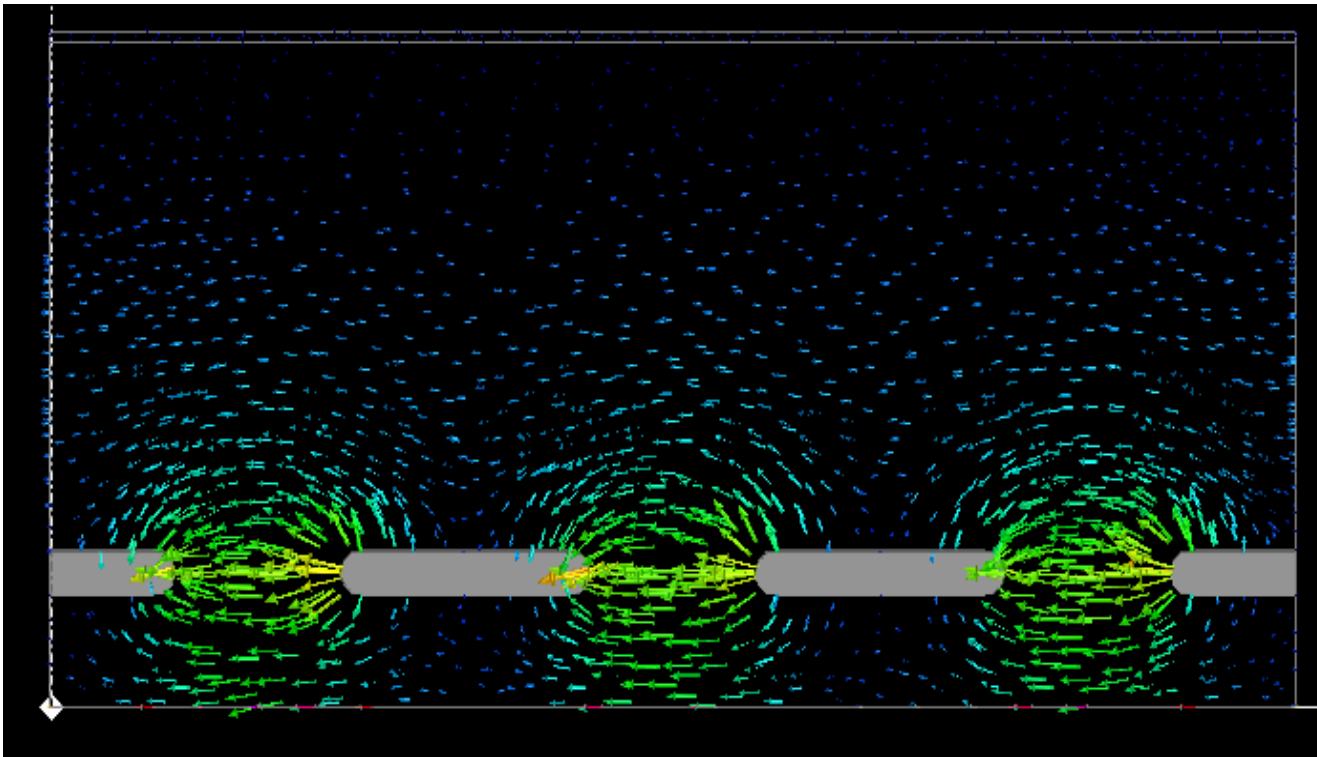

Phase Focusing

- Energy transferred to particle depends on V_{\max} and Ψ_0
 - Small deviation from nominal voltage V_{\max} results in particle velocity no longer matching design velocity fixed by length of drift sections.
 - Particles undergo a phase shift relative to RF voltage.
 - Synchronisation of particle motion and RF field is lost.
- Solution based on using $\Psi_0 < \pi/2$ so that the effective accelerating voltage is $V_{\text{eff}} < V_{\max}$
 - Assume particle gained too much energy in preceding stage and travelling faster than ideal particle and hence arrives earlier.
 - Sees average RF phase $\Psi = \Psi_0 - \Delta\Psi$ and is accelerated by voltage

$$V'_{\text{eff}} = V_{\max} \sin(\Psi_0 - \Delta\Psi) < V_{\max} \sin \Psi_0$$

which is below the ideal voltage.

- Particle gains less energy & slows down again until it returns to nominal velocity.
- All particles oscillate about nominal phase Ψ_0

Synchrotron Oscillations

- The periodic longitudinal particle motion about the nominal phase is called synchrotron oscillation.
- As the ideal particle encounters the RF voltage at exactly the nominal phase on each revolution, the RF frequency ω_{RF} must be an integer multiple of the revolution frequency ω_{rev}

$$h = \frac{\omega_{RF}}{\omega_{rev}}$$

where h is the harmonic number of the ring.

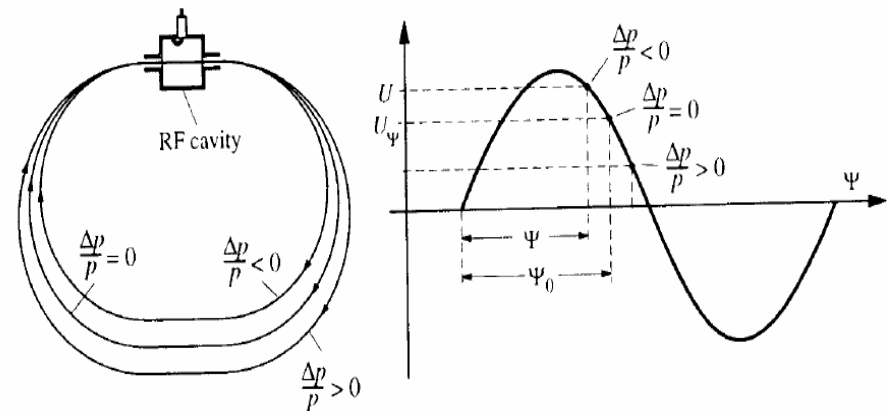

Phase focusing of relativistic particles in circular accelerators

Waves in Free Space

□ Wave parameters

$$\text{Velocity in vacuum } v = c = \frac{1}{\sqrt{\epsilon_0 \mu_0}}$$

$$\text{Velocity in medium } v = \frac{1}{\sqrt{\epsilon_0 \epsilon_r \mu_0 \mu_r}}$$

With ϵ_r being the dielectric constant and the magnetic permeability is μ_r

The ratio between the electric and magnetic fields is

$$\frac{E}{H} = 376.6 \sqrt{\frac{\mu_r}{\epsilon_r}} \quad (\Omega)$$

Plane transverse electric and magnetic wave (TEM) propagating in free space in x-direction.

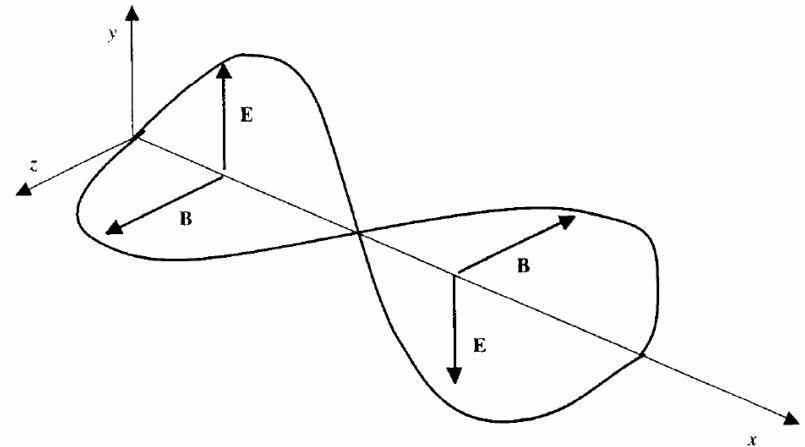

The Poynting flux (the local power flux) is

$$P = (E \times H) \quad W m^{-2}$$

Conducting Surfaces

- Consider waves in metal boxes, recall boundary conditions of a wave at a perfectly conducting metallic surface.
 - $E_{\text{tangential}}$ component and H_{normal} component to surface vanish.
- Skin depth – EM wave entering a conductor is damped to $1/e$ of initial amplitude in distance

$$\delta_s = \frac{1}{\sqrt{\pi f \mu_0 \mu_r \sigma}}$$

- Surface resistance $R_s = \frac{1}{\sigma \delta_s}$

Waveguides

- Propagation of EM wave in waveguide described by general wave equation

$$\nabla^2 E - \frac{1}{c^2} \ddot{E} = 0$$

- As we are interested only in spatial distribution

$$E(r, t) = E(r) e^{i\omega t} \quad \text{with } r = (x, y, z)$$

- Substituting yields

$$\nabla^2 E + k^2 E(r) = 0$$

with wavenumber

$$k = \frac{\omega}{c} = \frac{2\pi}{\lambda}$$

Waveguides

- Considering only z-component (propagation direction along waveguide) gives

$$\frac{\partial^2 E_z}{\partial x^2} + \frac{\partial^2 E_z}{\partial y^2} + \frac{\partial^2 E_z}{\partial z^2} = -k^2 E_z$$

- Which can be solved by using trial equation

$$E_z(x, y, z) = f_x(x) f_y(y) f_z(z)$$

- So that

$$\frac{f_x''}{f_x} + \frac{f_y''}{f_y} + \frac{f_z''}{f_z} = -k^2$$

Waveguides

Defining

$$k_x^2 \equiv -\frac{f_x''}{f_x} \quad k_y^2 \equiv -\frac{f_y''}{f_y} \quad k_z^2 \equiv -\frac{f_z''}{f_z}$$

yields

$$k_x^2 + k_y^2 + k_z^2 = k^2$$

which when setting

$$k_x^2 + k_y^2 = k_c^2$$

gives

$$k_z = \sqrt{k^2 - k_c^2}$$

Waveguides

- The wave propagation along the waveguide is described by

$$f_z'' + k_z^2 f_z = 0$$

from which the differential equation describing the electric field along the waveguide axis is found to be

$$\frac{\partial^2 E_z}{\partial z^2} + k_z^2 E_z = 0$$

whose solution is

$$E_z = E_0 e^{ik_z z}$$

Waveguides

- There are two regimes for waveguide operation:

$$k_z = \begin{cases} \text{complex} & \text{if } k_c^2 > k^2 \quad (\text{damping}) \\ \text{real} & \text{if } k_c^2 < k^2 \quad (\text{propagation}) \end{cases}$$

- The special value of the wavenumber k_c is the cut-off frequency and separates free propagation from damping.

Waveguides

- Corresponding cut-off wavelength is

$$\frac{1}{\lambda^2} = \frac{1}{\lambda_c^2} + \frac{1}{\lambda_z^2}$$

from which

$$\lambda_z = \frac{\lambda}{\sqrt{1 - \left(\frac{\lambda}{\lambda_c}\right)^2}}$$

Waveguides

- In the loss-free wave propagation regime, the wavelength λ_z is always greater than that in free space.
 - → Phase velocity of wave within waveguide is greater than speed of light

$$v_\phi = \frac{\omega \lambda_z}{2\pi} > c$$

- Dispersion relation for waveguides

$$\omega = c \sqrt{k_z^2 + \left(\frac{2\pi}{\lambda_c}\right)^2}$$

Rectangular Waveguides

- To transport the wave from the transmitter to the accelerator, rectangular waveguides are used.
- Dimensions of waveguide depend on cut-off wavelength.

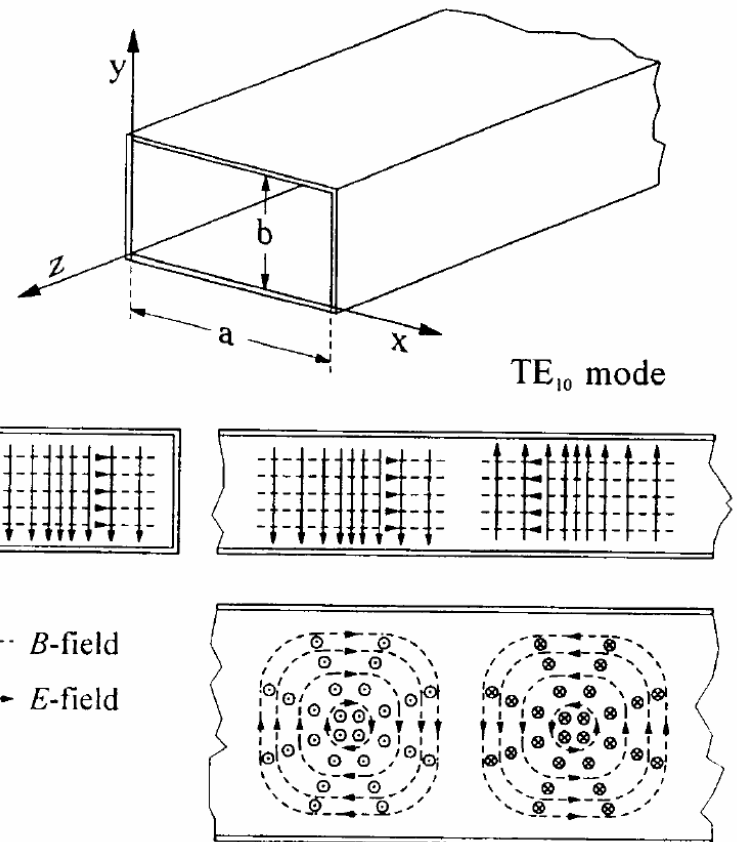

Rectangular Waveguides

- Cut-off Wavelength

$$f_x'' + k_x^2 f_x = 0$$

$$f_y'' + k_y^2 f_y = 0$$

$$f_x(x) = A \sin(k_x x) + B \cos(k_x x)$$

$$f_y(y) = C \sin(k_y y) + D \cos(k_y y)$$

- Constants A, B, C, D fixed by boundary conditions of wave propagation in waveguide
 - E-field tangential to conducting walls of waveguide vanish at surface of wall. (1)
 - B-field perpendicular to the conducting walls must vanish at the surface due to production of eddy currents. (2)

Rectangular Waveguides

- From boundary conditions

$$f_x(0) = f_y(0) = 0 \Rightarrow B = D = 0$$

$$f_x(a) = f_y(b) = 0 \Rightarrow k_x a = m\pi \quad ; \quad k_y b = n\pi$$

$$\Rightarrow k_c^2 = \left(\frac{m\pi}{a}\right)^2 + \left(\frac{n\pi}{b}\right)^2$$

$$\Rightarrow \lambda_c^2 = \frac{2}{\sqrt{\left(\frac{m}{a}\right)^2 + \left(\frac{n}{b}\right)^2}}$$

- There are an unlimited number of configurations, called waveguide modes.
 - Only a few are of practical use.

Rectangular Waveguides

- TE₁₀-mode (transverse electric)
 - Electric field lines only run perpendicular to direction of wave motion.
 - Or H₁₀ as the magnetic field lines run in the waveguide direction.

$$E_x = 0$$

$$E_y = \hat{E} \sin\left(\frac{\pi x}{a}\right) e^{-ik_z z}$$

$$E_z = 0$$

$$H_x = \frac{\hat{E}}{Z_0} \frac{\lambda}{\lambda_z} \sin\left(\frac{\pi x}{a}\right) e^{-ik_z z}$$

$$H_y = 0$$

$$H_z = -i \frac{\hat{E}}{Z_0} \frac{\lambda}{2a} \cos\left(\frac{\pi x}{a}\right) e^{-ik_z z}$$

The individual electric and magnetic field components of TE₁₀-mode.

\hat{E} = arbitrary amplitude

Z_0 = waveguide impedance

Cylindrical Waveguides

- The same boundary conditions apply at the surface of the conducting cylinder as for rectangular waveguides.
- The most important mode for acceleration is TM_{01} (or E_{01}).
 - Only transverse magnetic field lines are present.
 - Electrical field lines run parallel to cylinder axis and thus can accelerate charged particles as they travel through waveguide.

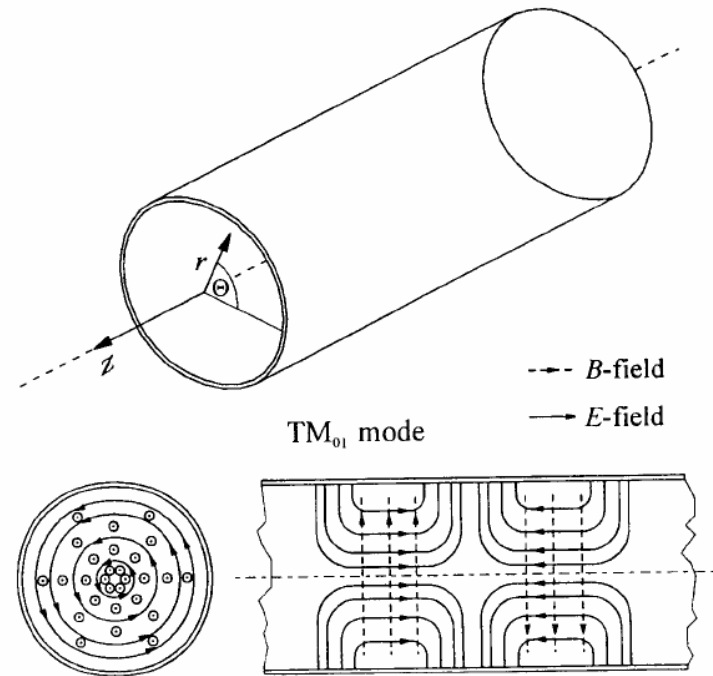

Cylindrical Waveguides

- Electromagnetic Field Components

$$E_r = -i \hat{E} \frac{k_z}{k_c} J_0'(k_c r) e^{-ik_z z}$$

$$E_\theta = 0$$

$$E_z = \hat{E} J_0(k_c r) e^{-ik_z z}$$

$$H_r = 0$$

$$H_\theta = -i \frac{\hat{E}}{Z_0} \frac{k}{k_c} J_0'(k_c r) e^{-ik_z z}$$

$$H_z = 0$$

Cylindrical Waveguides

■ Cut-off Wavelength

- Electrical field components running parallel to the conducting cylinder vanish at surface

$$E_z \left(\frac{D}{2} \right) = 0$$

Where D is the cylinder diameter

$$J_0 \left(k_c \frac{D}{2} \right) = 0$$

The above condition is only satisfied if Bessel function vanishes

$$k_c = \frac{2x_1}{D}$$

If x_1 ($=2.40483$) is first zero of Bessel function

$$\lambda_c = \frac{\pi D}{x_1}$$

with the corresponding cut-off wavelength