

# Long-lived particles at the Energy Frontier

30th Rencontres de Blois on  
"Particle Physics and Cosmology"

5 June 2018

David Curtin  
University of Toronto

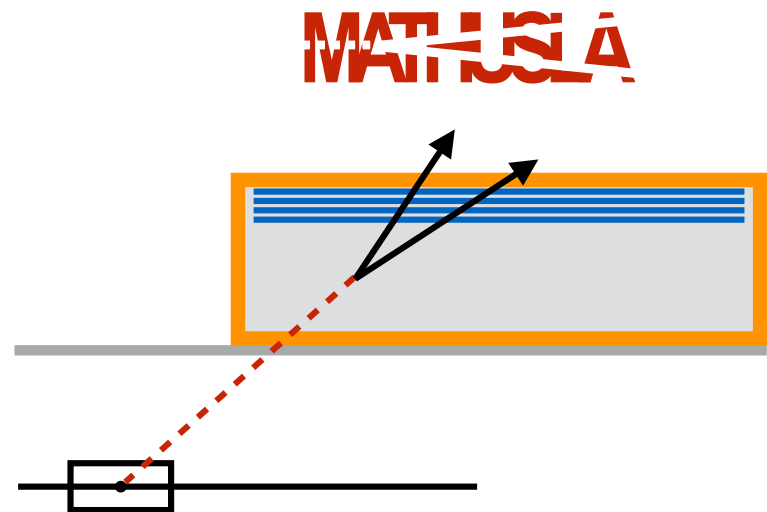

# Context

We proposed MATHUSLA as a general-purpose external LLP detector for the HL/HE-LHC

Chou, DC, Lubatti 1606.06298

Theory community has been working on coherent formulation of the MATHUSLA physics case, white paper out in 1-2 weeks

→ Study of general theory motivations for LLP searches

## Long-Lived Particles at the Energy Frontier: The MATHUSLA Physics Case

### *Editors:*

*David Curtin<sup>1</sup>, Marco Drewes<sup>2</sup>, Matthew McCullough<sup>3</sup>, Patrick Meade<sup>4</sup>, Rabindra Mohapatra<sup>5</sup>, Jessie Shelton<sup>6</sup>, Brian Shuve<sup>7</sup>*

*Contributors: Elena Accomando, Cristiano Alpigiani, Stefan Antusch, Juan Carlos Arteaga-Velazquez, Brian Batell, Martin Bauer, Nikita Blinov, Mario Rodriguez Cahuantzi, Jae Hyeok Chang, Eung Jin Chun, Raymond Co, Tim Cohen, Peter Cox, Nathaniel Craig, Csaba Csaki, Yanou Cui, Francesco D'Eramo, Luigi Delle Rose, P. S. Bhupal Dev, Keith Dienes, Jeff Asaf Dror, Rouven Essig, Jason Evans, Jared Evans, Oliver Fischer, Thomas Flacke, Anthony Fradette, Claudia Frugiuele, Elina Fuchs, Tony Gherghetta, Dmitry Gorbunov, Rick S. Gupta, Claudia Hagedorn, Lawrence Hall, Juan Carlos Helo Herrera, Martin Hirsch, Yonit Hochberg, Anson Hook, Seyda Ipek, Sunghoon Jung, Simon Knapen, Eric Kuflik, Zhen Liu, Salvator Lombardo, Henry Lubatti, Emiliano Molinaro, Karen Salome Caballero Mora, Stefano Moretti, Natsumi Nagata, Matthias Neubert, Jose Miguel No, Emmanuel Olaiya, Gilad Perez, David Pinner, Maxim Pospelov, Matthew Reece, Rinaldo Santonico, Matthias Schlaffer, Claire H. Shepherd-Themistocleous, Andrew Spray, Daniel Stolarski, Arturo Fernandez Tellez, Andrea Thamm, Brooks Thomas, Yuhsin Tsai, Brock Tweedie, Martin Alfonso Subieta Vasquez, Stephen West, Charles Young, Felix Yu, Bryan Zaldivar, Yongchao Zhang, Kathryn Zurek.*

# Context

We proposed MATHUSLA as a general-purpose external LLP detector for the HL/HE-LHC

Chou, DC, Lubatti 1606.06298

Theory community has been working on coherent formulation of the MATHUSLA physics case, white paper out in 1-2 weeks

→ Study of general theory motivations for LLP searches

## Long-Lived Particles at the Energy Frontier: The MATHUSLA Physics Case

### Editors:

David Curtin<sup>1</sup>, Marco Drewes<sup>2</sup>, Matthew McCullough<sup>3</sup>, Patrick Meade<sup>4</sup>, Rabindra Mohapatra<sup>5</sup>, Jessie Shelton<sup>6</sup>, Brian Shuve<sup>7</sup>

Contributors: Elena Accomando, Cristiano Alpigiani, Steffen  
Arteaga-Velazquez, Brian Batell, Martin Bauer, Nikita Blinov,  
Hyeok Chang, Eung Jin Chun, Raymond Co, Tim Cohen,  
Yanou Cui, Francesco D'Eramo, Luigi Delle Rose, P. S. Bhowmik,  
Rouven Essig, Jason Evans, Jared Evans, Oliver Fischer,  
Fruquieue, Elina Fuchs, Tony Gherghetta, Dmitry Gorbunov,  
Lawrence Hall, Juan Carlos Helo Herrera, Martin Hirsch,  
Sunghoon Jung, Simon Knapen, Eric Kuflik, Zhen Liu, Saikat  
Molinaro, Karen Salome Caballero Mora, Stefano Moretti,

Miguel No, Emmanuel Olaiya, Gilad Perez, David Pinner, Maxim Pospelov, Matthew Reece, Rinaldo  
Santonico, Matthias Schlaffer, Claire H. Shepherd-Themistocleous, Andrew Spray, Daniel Stolarski,  
Arturo Fernandez Tellez, Andrea Thamm, Brooks Thomas, Yuhsin Tsai, Brock Tweedie, Martin  
Alfonso Subieta Vasquez, Stephen West, Charles Young, Felix Yu, Bryan Zaldivar, Yongchao Zhang,  
Kathryn Zurek.

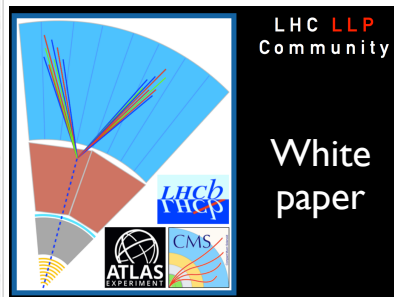

Searches for long-lived particles beyond the Standard Model at the Large Hadron Collider

Abstract: Searches for long-lived particles (LLPs) beyond the Standard Model at the Large Hadron Collider — particles that can have non-negligible lifetimes and decay to SM particles within detectors but substantially displaced from the interaction vertex — constitute a rich, challenging, and

LHC-LLP white paper focusing on guiding LLP searches at main detectors:

Together: comprehensive framework to generally discuss LLPs at the LHC!

# Outline

1. Why look for LLPs at the LHC?
2. The MATHUSLA detector
3. Comparing MATHUSLA and the main detectors
4. MATHUSLA Physics Reach
5. Bonus: Cosmic Ray Physics
6. Timeline
7. Conclusion

# I. Why look for LLPs at the LHC?

# Motivation for (neutral) LLPs

## 1. Analogy to SM

Variety of mechanisms can suppress particle decay width: small coupling, approximate symmetries, heavy mediator, lack of phase space.

## 2. Bottom-up Theoretical Motivation

Same mechanisms can be active in BSM theories.

Additional motivation from symmetry structure of QFT: hidden sectors are generic possibility (**Hidden Valleys, dark photons, singlet extensions**, etc)

Higgs boson particularly enticing probe of relatively light new physics (Exotic Higgs Decays)

# Motivation for (neutral) LLPs

## 3. Where is the new physics?

**Completely pragmatic.** So far, searches at LHC for (mostly prompt) BSM signals have only yielded null results.

**LHC is great for the *Lifetime Frontier* (energy  $\times$  intensity)!**  
Very long-lived particles are inherently *rare* signals but you also want *high energy* to produce them via high-scale processes

## 4. Top-Down Theoretical Motivation

LLPs can arise in almost any BSM theory! Often play intrinsic role in the mechanism at the heart of the theory!

Could be involved in addressing big fundamental questions like Naturalness, Dark Matter, Baryogenesis, Neutrino Masses...

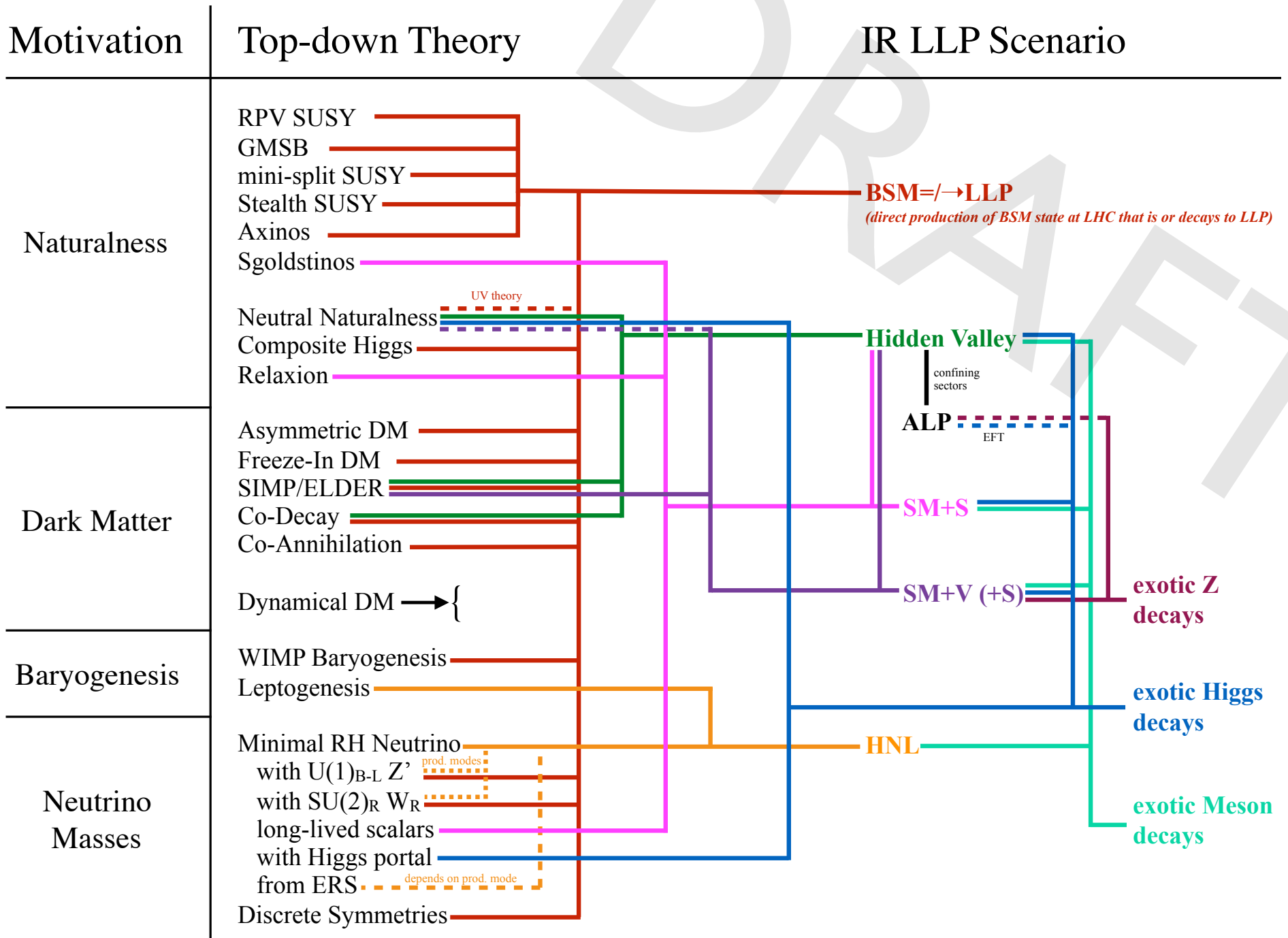



... come back to this in more detail later....

**Lifetime frontier should be a focus of the  
upcoming decade at the LHC**

## 2. The MATHUSLA Detector

**MATHUSLA**  
**MATHUSLA**  
MAssive Timing Hodoscope  
for Ultra-Stable Neutral Particles

Chou, DC, Lubatti 1606.06298  
DC, Peskin 1705.06327  
Physics Case White Paper 1806.xxxxx  
Letter of Intent 18xx.xxxxx

### Easy reading:

Physics Today article about LLPs and hidden sectors (DC, Raman Sundrum, June 2017)  
<http://physicstoday.scitation.org/doi/10.1063/PT.3.3594>

In-depth feature article in Quanta and Wired magazine, September 2018

<https://www.quantamagazine.org/how-the-hidden-higgs-could-reveal-our-universes-dark-sector-20170926/> <https://www.wired.com/story/hidden-higgs-dark-sector/>

“Nuclear Detectives Hunt Invisible Particles That Escaped the World's Largest Atom Smasher”, Live Science, May 2018 <https://www.livescience.com/62633-lhc-stray-particles-mathusla-detection.html>

PHYSICS TODAY

Quanta

WIRED

LIVESCIENCE

# An external LLP detector for the HL-LHC

Chou, DC, Lubatti  
1606.06298

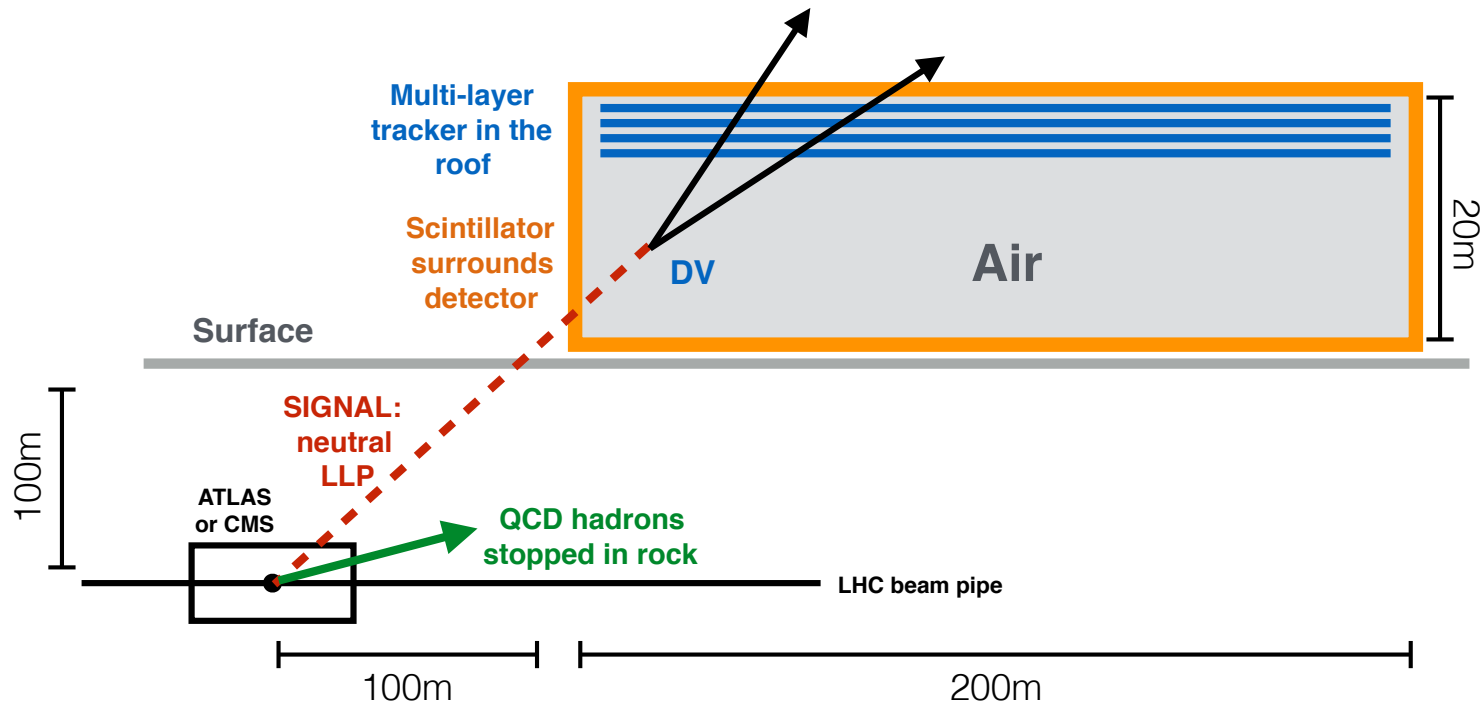

... searches for LLPs by reconstructing displaced vertices in air-filled decay volume.

# Background Rejection

LLP DV signal has to satisfy many stringent geometrical and timing requirements (“4D DV” with cm/ns precision)

These signal requirements + a few extra geometry and timing cuts veto all backgrounds!

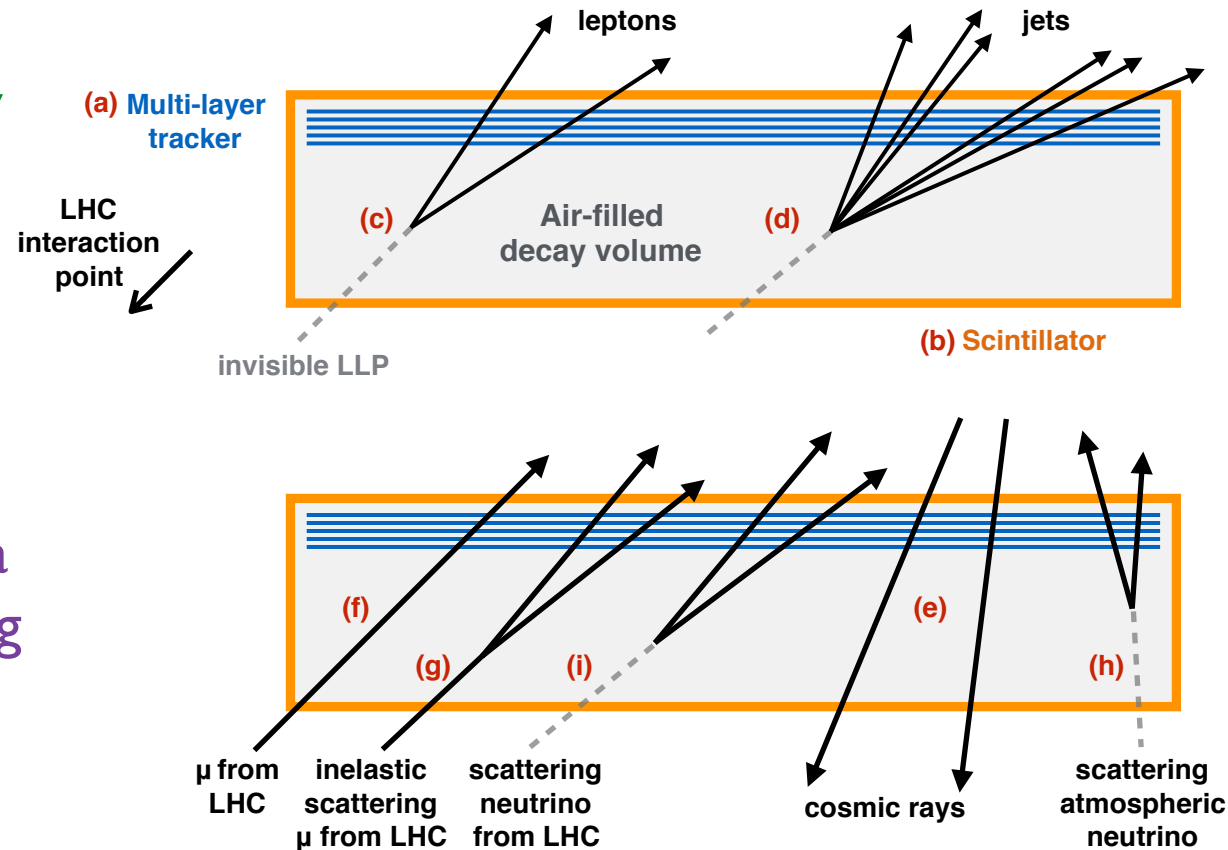

**MATHUSLA can search for neutral LLP decays with near-zero backgrounds!**  
(see backup slides for more details)

# Practicalities

Design is completely **flexible** (precise position doesn't matter) and **scalable** (probe  $\sigma_{\text{LLP}} \propto I/\text{area}$ ).

→ final design will be **modular** (e.g. 20x20x20m segments).  
**Allows for incremental deployment and mass production.**

Reliance on well-understood technology (**RPC trackers**, **plastic scintillators**) means this could be implemented in time for the HL-LHC.

... but parasitic nature of detector means it could function without modification for HE-LHC!

Unofficial cost estimates: ~ 50 million USD.  
More precise estimates will be part of LOI.

CERN owns some empty land of *approximately* right size near CMS



# MATHUSLA experimental collaboration

Working on preparing Letter of Intent (this year), detector design studies, background studies, etc... **(Join us!)**

Name	Email	Institution
Cristiano Alpigiani	<a href="mailto:Cristiano.Alpigiani@cern.ch">Cristiano.Alpigiani@cern.ch</a>	University of Washington - Seattle
Audrey Katherine Kvam	<a href="mailto:audrey.katherine.kvam@cern.ch">audrey.katherine.kvam@cern.ch</a>	University of Washington - Seattle
Henry Lubatti	<a href="mailto:lubatti@u.washington.edu">lubatti@u.washington.edu</a>	University of Washington - Seattle
Mason Louis Proffitt	<a href="mailto:mason.louis.proffitt@cern.ch">mason.louis.proffitt@cern.ch</a>	University of Washington - Seattle
Joseph Rothberg	<a href="mailto:Joseph.Rothberg@cern.ch">Joseph.Rothberg@cern.ch</a>	University of Washington - Seattle
Gordon Watts	<a href="mailto:gwatts@uw.edu">gwatts@uw.edu</a>	University of Washington - Seattle
Emma Torró Pastor	<a href="mailto:emma.torro.pastor@cern.ch">emma.torro.pastor@cern.ch</a>	University of Washington - Seattle
Yan Benhammou	<a href="mailto:Yan.Benhammou@cern.ch">Yan.Benhammou@cern.ch</a>	Tel Aviv University
Meny Ben Moshe	<a href="mailto:Menyb@post.tau.ac.il">Menyb@post.tau.ac.il</a>	Tel Aviv University
Tingting Cao	<a href="mailto:Tingting.cao@cern.ch">Tingting.cao@cern.ch</a>	Tel Aviv University
Erez Etzion	<a href="mailto:Erez.Etzion@cern.ch">Erez.Etzion@cern.ch</a>	Tel Aviv University
Gilad Mizrahi	<a href="mailto:gilad.mizrahi@cern.ch">gilad.mizrahi@cern.ch</a>	Tel Aviv University
Yiftah Silver	<a href="mailto:yiftahsi@gmail.com">yiftahsi@gmail.com</a>	Tel Aviv University
David Curtin	<a href="mailto:david.r.curtin@gmail.com">david.r.curtin@gmail.com</a>	University of Toronto
Mario Rodriguez Cahuantzi	<a href="mailto:mario.rodriguez.cahuantzi@cern.ch">mario.rodriguez.cahuantzi@cern.ch</a>	Autonomous University of Puebla
Martin Hentschinski	<a href="mailto:martin.hentschinski@gmail.com">martin.hentschinski@gmail.com</a>	Autonomous University of Puebla
Arturo Fernandez Tellez	<a href="mailto:Arturo.Fernandez.Tellez@cern.ch">Arturo.Fernandez.Tellez@cern.ch</a>	Autonomous University of Puebla
Martin Alfonso Subieta Vasquez	<a href="mailto:martin.alfonso.subieta.vasquez@cern.ch">martin.alfonso.subieta.vasquez@cern.ch</a>	Autonomous University of Puebla
Abraham Villatoro Tello	<a href="mailto:abraham.villatoro.tello@cern.ch">abraham.villatoro.tello@cern.ch</a>	Autonomous University of Puebla

John Paul Chou	<a href="mailto:john.paul.chou@cern.ch">john.paul.chou@cern.ch</a>	Rutgers, State University of New Jersey
Steffie Ann Thayil	<a href="mailto:steffie.ann.thayil@cern.ch">steffie.ann.thayil@cern.ch</a>	Rutgers, State University of New Jersey
Antonios Agapitos	<a href="mailto:antonios.agapitos@cern.ch">antonios.agapitos@cern.ch</a>	Rutgers, State University of New Jersey
Luke Kasper	<a href="mailto:lukekasper25@gmail.com">lukekasper25@gmail.com</a>	Rutgers, State University of New Jersey
Charlie Young	<a href="mailto:young@slac.stanford.edu">young@slac.stanford.edu</a>	SLAC
Paolo Camarri	<a href="mailto:paolo.camarri@cern.ch">paolo.camarri@cern.ch</a>	Università di Tor Vergata
Roberto Cardarelli	<a href="mailto:roberto.cardarelli@roma2.infn.it">roberto.cardarelli@roma2.infn.it</a>	Università di Tor Vergata
Rinaldo Santonico	<a href="mailto:santonico@roma2.infn.it">santonico@roma2.infn.it</a>	Università di Tor Vergata
Barbara Liberti	<a href="mailto:barbara.liberti@roma2.infn.it">barbara.liberti@roma2.infn.it</a>	Università di Tor Vergata
Antonio Policicchio	<a href="mailto:Antonio.Policicchio@cern.ch">Antonio.Policicchio@cern.ch</a>	La Sapienza, Roma
Marco Schioppa	<a href="mailto:Marco.Schioppa@cern.ch">Marco.Schioppa@cern.ch</a>	Università della Calabria
Giovanni Marsella	<a href="mailto:giovanni.marsella@cern.ch">giovanni.marsella@cern.ch</a>	INFN Lecce e Università del Salento
Roberto Guida	<a href="mailto:Roberto.Guida@cern.ch">Roberto.Guida@cern.ch</a>	CERN

(member list probably outdated)

**contact: [mathusla.experiment@cern.ch](mailto:mathusla.experiment@cern.ch)**

# MATHUSLA Test Stand

2.5 x 2.5 x 5m MATHUSLA-type detector taking data in ATLAS SXI

Built using repurposed detectors (RPCs from ARGO, scintillators from D0 muon system) to take background measurements from cosmics and LHC collisions.

Will calibrate Monte Carlo simulations and allow background rejection strategies to be tested.

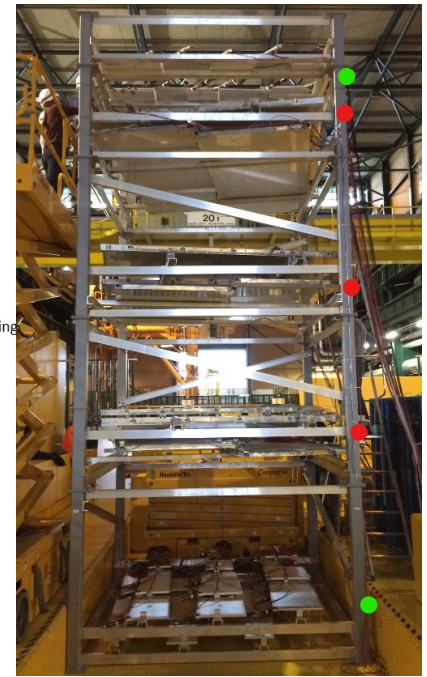
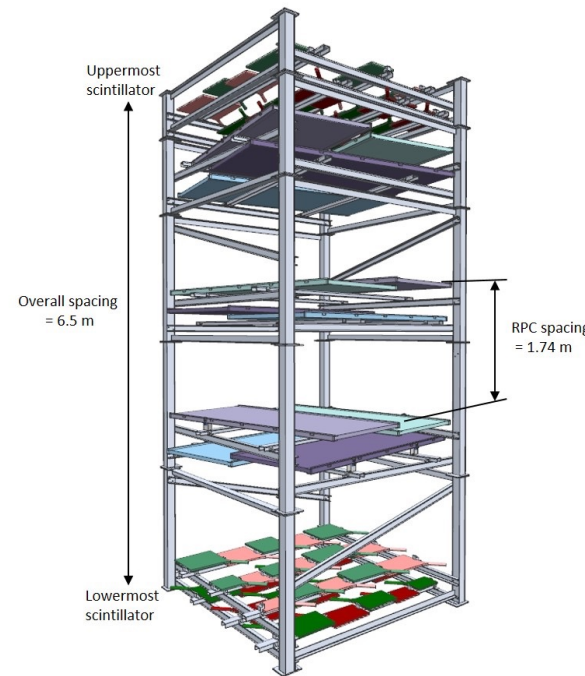

# Sensitivity

$$\text{MATHUSLA} \approx \text{ATLAS/CMS} - \text{short-lifetime sensitivity} + \text{zero BG, no trigger issues}$$

similar geometric acceptance for LLP decays in long-lifetime limit...
... you sacrifice sensitivity for short lifetimes...
... but you gain clean environment for LLP searches

Very easy to estimate sensitivity at MATHUSLA:

$$N_{\text{MATHUSLA}} \approx (\# \text{ LLPs produced at LHC}) \times P_{\text{decay}}^{\text{MATHUSLA}}$$

$$P_{\text{decay}}^{\text{MATHUSLA}}(c\tau) \approx \epsilon_{\text{geometric}} P_{\text{decay}}(\bar{b}c\tau, L_1, L_2)$$

only modest  $O(1)$  dependence on LLP production process.

$\sim 0.05$

$$\sim \frac{(30\text{m})}{\bar{b}c\tau}$$

in long lifetime regime



# Sensitivity

LLP cross section reach

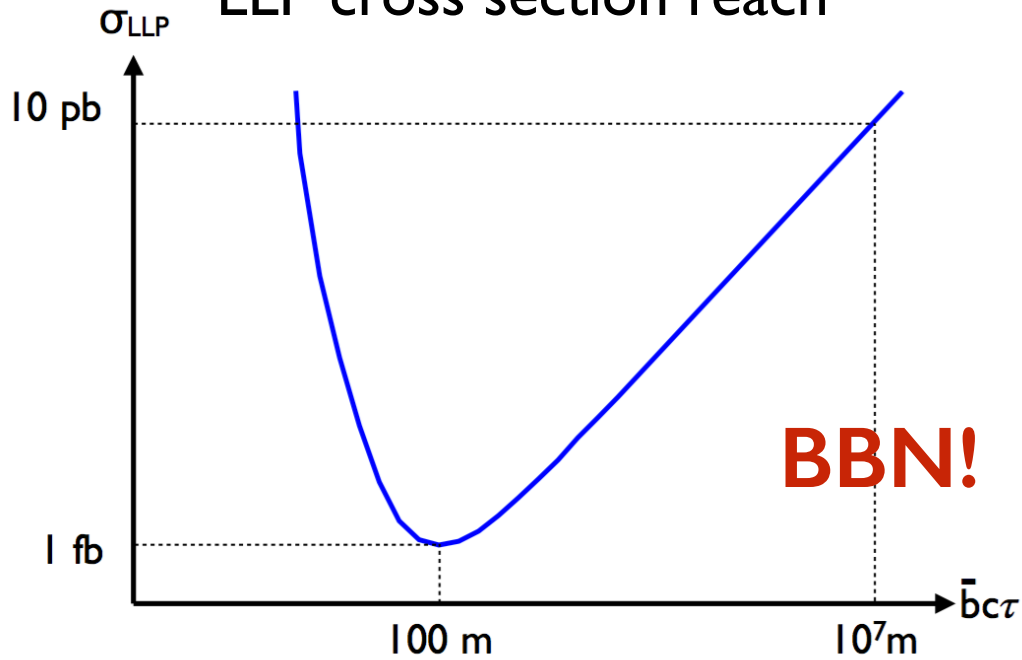

Some example production xsecs

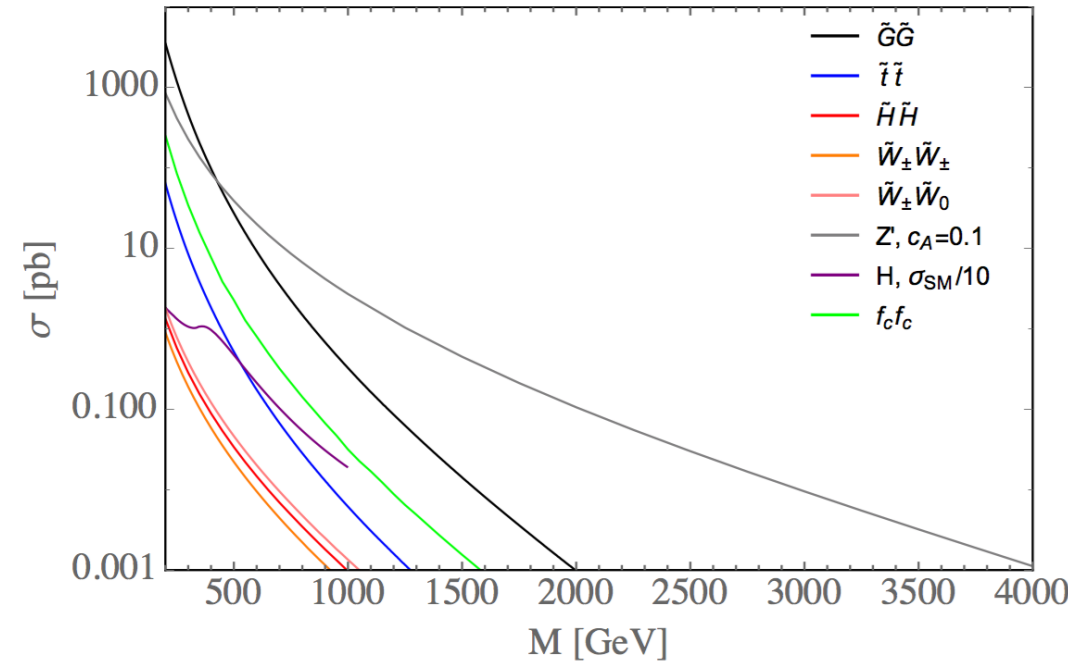

$$\bar{b} = \frac{m_{\text{eff}}}{2m_{\text{LLP}}}$$

$$\bar{b}c\tau_{\text{max}} \sim (10^3 \text{ m}) \left( \frac{\sigma_{\text{sig}}^{\text{LHC}}}{\text{fb}} \right)$$

Any LLP production process with  $\sigma > \text{fb}$  can give signal.

**Probe TeV+ scales!**

# 3. LLPs at the LHC: Comparing MATHUSLA and the main detectors

# MATHUSLA vs ATLAS/CMS

Obviously main detectors are better at short lifetimes, so focus on long lifetimes  $bc\tau \gtrsim 100\text{m}$ .

⇒ Main detector search should only require one LLP decay

One important benchmark:

$h \rightarrow XX$ ,  $X = \text{LLP}$  decays via Higgs portal (mostly hadronically)

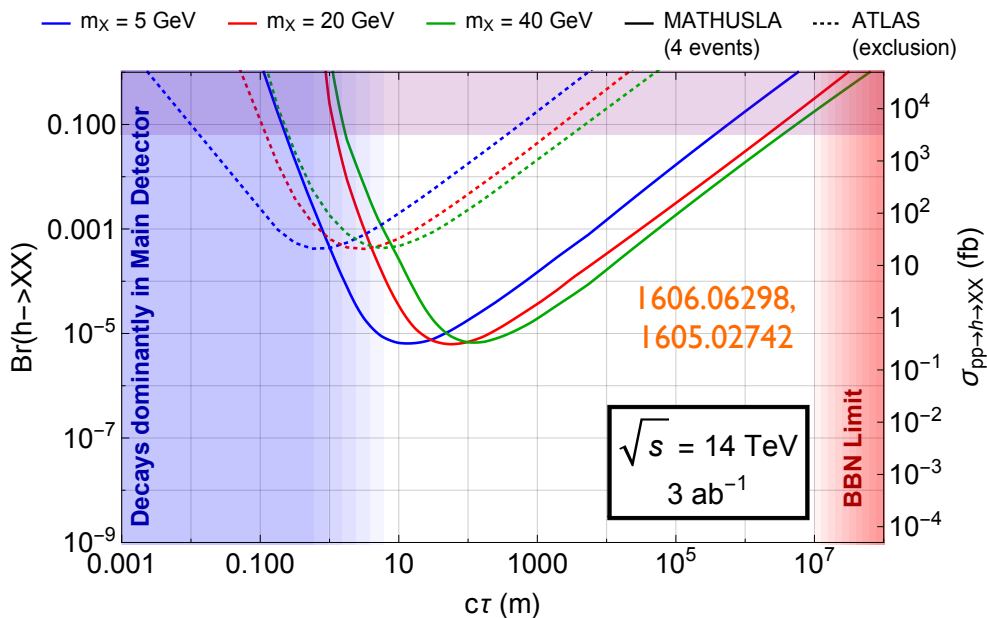

We have reasonable main detector comparison from study of inclusive single-LLP search in ATLAS Muon System (likely best-case projection for HL-LHC)

⇒ **MATHUSLA wins by  $10^3$ !**

How does MATHUSLA compare to ATLAS/CMS for other LLP signals?

# LLPs @ LHC main detectors

Try and understand the space of LLP signals at the main detectors.

Important & related issues: **Background** and **Triggering**:

LLPs are spectacular *geometric* signals!

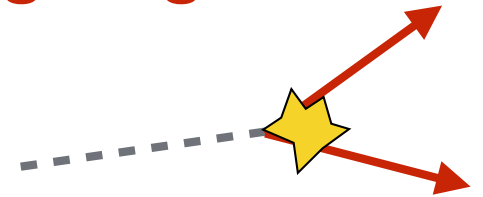

→ smaller BG than prompt, but often difficult to calculate.

It helps if we can cut on non-geometric requirements (like leptons, jet energy) to cut BG to “zero”.

→ **DV + X search**

→ triggering on geometry of LLP decay at LI is presently impossible (except ATLAS MS/CALO).

*Would need tracker info (vertexing) at LI!*

⇒ use existing LI triggers that are optimized for prompt objects.

# Comparing MATHUSLA to ATLAS/CMS

Quantifying main detector LLP **signal** is relatively easy at  $O(1)$  level, similar to at MATHUSLA

**Big Problem:** searches with single LLPs at main detectors often have *some* backgrounds.  
**Difficult to quantify, not enough HL-LHC studies. (Yet.)**

This makes general and precisely quantitative comparison of sensitivities very involved.

**Luckily, we can still extract very useful intuition from some simple estimates and some existing examples.**

# Model-Independent Approach

Define *long-lifetime sensitivity gain* at MATHUSLA:

$$R_s \equiv \frac{\sigma_{\text{sig}}^{\text{LHC limit}}}{\sigma_{\text{sig}}^{\text{MATHUSLA limit}}} \Big|_{bc\tau \gg 200\text{m}}$$

If  $R_s > 1$ , MATHUSLA has better sensitivity than main detectors.

Can we estimate this number for different LLP signals?

# Model-Independent Approach

Compare **MATHUSLA search for LLP  $X$**  to **main detector search for single  $X$  decay**, with some **geometrical requirements** on where  $X$  decays (tracker, MS, ..) and some **non-geometrical trigger/cut requirements**.

# Model-Independent Approach

Compare **MATHUSLA search for LLP X** to **main detector search for single X decay**, with some **geometrical requirements** on where X decays (tracker, MS, ..) and some **non-geometrical trigger/cut requirements**.

$$R_s \approx \begin{cases} \left( \frac{P_{\text{decay}}^{\text{MATH}}}{P_{\text{decay}}^{\text{LHC}}} \right) \left( \frac{\epsilon_{\text{LLP}}^{\text{MATH}}}{\epsilon_{\text{LLP}}^{\text{LHC}}} \right) \frac{1}{\epsilon_{\text{cuts}}^{\text{LHC}}} & \text{if the HL-LHC search is BG-free} \\ \sqrt{\frac{\sigma_{\text{BG after cuts}}}{\sigma_{R_s}}} & \text{if the HL-LHC search has BG} \gtrsim 10^{-3} \text{ fb} \end{cases}$$

$$\sigma_{R_s} \approx (10^{-3} \text{ fb}) \left( \frac{P_{\text{decay}}^{\text{LHC}}}{P_{\text{decay}}^{\text{MATH}}} \right)^2 \left( \frac{\epsilon_{\text{LLP}}^{\text{LHC}}}{\epsilon_{\text{LLP}}^{\text{MATH}}} \right)^2 (\epsilon_{\text{cuts}}^{\text{LHC}})^2$$



# Model-Independent Approach

Compare **MATHUSLA search for LLP X** to **main detector search for single X decay**, with some **geometrical requirements** on where X decays (tracker, MS, ..) and some **non-geometrical trigger/cut requirements**.

**efficiency of main detector trigger/kinematic/decay branching ratio requirements**

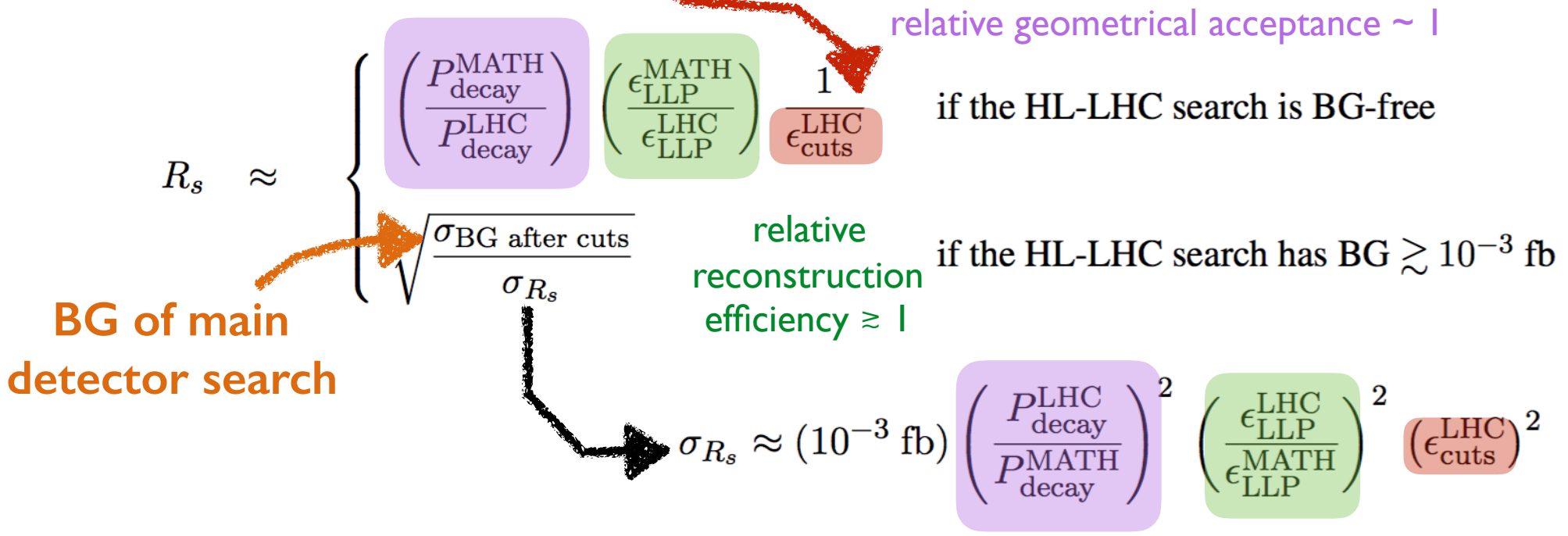
$$\frac{P_{\text{decay}}^{\text{LHC}}}{P_{\text{decay}}^{\text{MATH}}} \approx \begin{cases} 2.2 & \text{ATLAS Muon System} \\ 0.8 & \text{ATLAS HCAL} \\ 1.0 & \text{ATLAS or CMS tracker (full volume)} \\ 0.25 & \text{ATLAS tracker (DV reconstruction volume)} \end{cases}$$

# Model-Independent Approach

Compare **MATHUSLA search for LLP X** to **main detector search for single X decay**, with some **geometrical requirements** on where X decays (tracker, MS, ..) and some **non-geometrical trigger/cut requirements**.

**efficiency of main detector  
trigger/kinematic/decay  
branching ratio requirements**

$$\frac{P_{\text{decay}}^{\text{LHC}}}{P_{\text{decay}}^{\text{MATH}}} \approx \begin{cases} 2.2 & \text{ATLAS Muon System} \\ 0.8 & \text{ATLAS HCAL} \\ 1.0 & \text{ATLAS or CMS tracker (full volume)} \\ 0.25 & \text{ATLAS tracker (DV reconstruction volume)} \end{cases}$$

$$R_s \approx \begin{cases} \left( \frac{P_{\text{decay}}^{\text{MATH}}}{P_{\text{decay}}^{\text{LHC}}} \right) \left( \frac{\epsilon_{\text{LLP}}^{\text{MATH}}}{\epsilon_{\text{LLP}}^{\text{LHC}}} \right) \frac{1}{\epsilon_{\text{cuts}}^{\text{LHC}}} \\ \sqrt{\frac{\sigma_{\text{BG after cuts}}}{\sigma_{R_s}}} \end{cases}$$

if the HL-LHC search is BG-free

if the HL-LHC search has  $\text{BG} \gtrsim 10^{-3} \text{ fb}$

**BG of main  
detector search**

$$\sigma_{R_s} \approx (10^{-3} \text{ fb}) \left( \frac{P_{\text{decay}}^{\text{LHC}}}{P_{\text{decay}}^{\text{MATH}}} \right)^2 \left( \frac{\epsilon_{\text{LLP}}^{\text{LHC}}}{\epsilon_{\text{LLP}}^{\text{MATH}}} \right)^2 (\epsilon_{\text{cuts}}^{\text{LHC}})^2$$

# Upshot

MATHUSLA will have better sensitivity than ATLAS/CMS in the long-lifetime regime whenever the corresponding main-detector LLP search suffers from *\*any\** difficulties with

- backgrounds  $> ab$
- trigger efficiency
- cut requirements

We can plug in BG numbers for future searches, once they are available, and get more precise Rs number.

# A few known examples...

LLPs decaying into **well-separated leptons with  $m > O(10)$  GeV**: negligible background, trigger easily,  **$R_s \sim 1$**

1411.6977

Probably similar if LLP decaying into anything is produced in association with (hard enough) leptons. **Pay Br penalty?  $R_s \sim 1/Br!$**

but if **LLP  $m < \sim 10$  GeV and decays to leptons**, have displaced lepton jets!  $\sigma_{BG}$  after cuts  $\sim 10$  fb  $\rightarrow$   **$R_s \sim 10-100?$**

ATLAS-CONF-2016-042

**LLP decays hadronically with  $m < O(100s)$  GeV** and nothing else in event: ATLAS MS,  $\sigma_{BG}$  after cuts  $\sim 100$ fb,  **$R_s \sim 1000!$**

1606.06298,  
1605.02742

**LLP decays hadronically with  $m > \text{few } 100$  GeV**, or produced in association with **high-energy jets**, will pass LI triggers, can look with CMS displaced jet triggers.  $\sigma_{BG}$  after cuts  $< \sim$  ab  $\rightarrow$   **$R_s \sim 1$**

1411.6530

# Rules of thumb

ATLAS/CMS win at short lifetimes, and for LLPs with highly conspicuous prompt or decay final states (high-mass jet or leptonic decays, production in association with hard jets etc)

MATHUSLA wins at long lifetimes for anything else, e.g.

LLPs with  $m < \sim O(100 \text{ GeV})$  and hadronic decays

LLPs decaying to lepton jets

LLPs decaying to photons?? (if MATHUSLA can see?)

LLPs with subdominant fraction of leptons in final state

with 10-1000x better LLP xsec sensitivity

**These are LLP searches that will likely remain difficult at main detectors even after LLP search program has matured!**

# What about MET searches?

Those are great if the LLP production xsec is sizable and MET is  $>$  few 100 GeV.

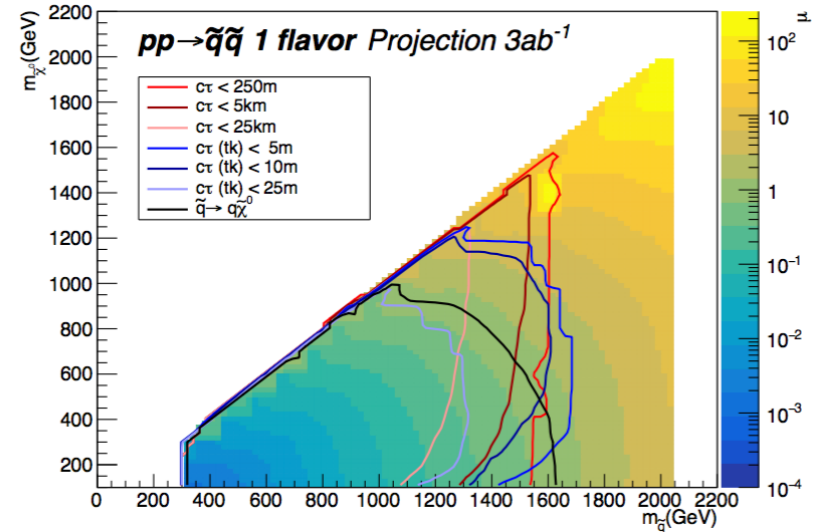
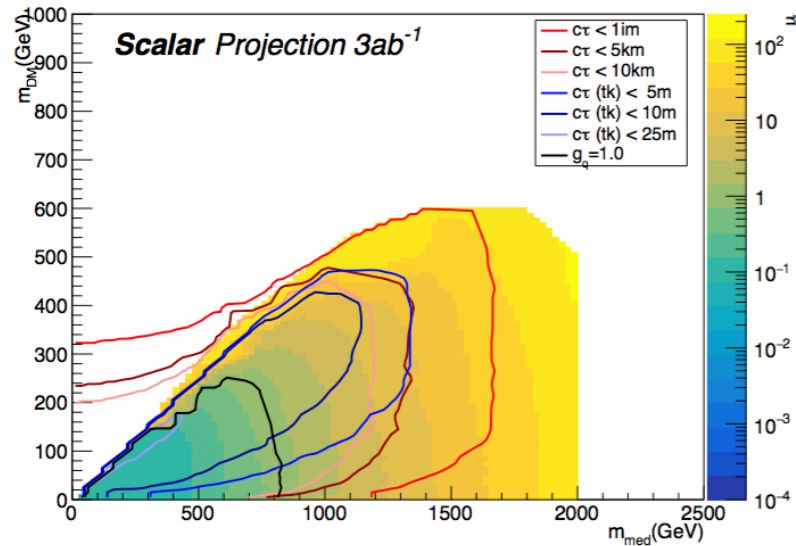

For **LLP pair production** (e.g. DM simplified models with unstable invisible particle) or **SUSY-type models with slightly squeezed spectra**, MATHUSLA can have much larger mass reach than main detector MET search!

## 4. MATHUSLA Physics Reach

Divide discussion into two “great” classes,  
in all of which **MCFODO**

(**M**athusla **C**ould be **F**irst or **O**nly **D**iscovery **O**pportunity)

- 1) BSM scenarios where neutral LLPs at MATHUSLA are **strongly motivated & intrinsic** part of theory mechanism
- 2) BSM scenarios where neutral LLPs at MATHUSLA are a **strongly motivated generic** possibility, often as part of a larger theory or parameter space.



# I) intrinsic

BSM Scenario	Role of LLPs	Typical $c\tau$	Role of MATHUSLA	Sec.	Fig.
Neutral Naturalness	Discrete symmetry stabilizing Higgs mass $\rightarrow$ Hidden Valley with Higgs portal. Cosmology $\rightarrow$ HV particles are LLPs.	Any, but $\mathbb{Z}_2$ arguments favor lower $\hat{\Lambda}_{QCD}$ and hence long lifetimes.	Mirror glueballs with long lifetimes can only be discovered at MATHUSLA.	4.2	22, 23
WIMP Baryogenesis	Out-of-equilibrium decay of WIMP-like LLP produces baryon asymmetry.	For weak-scale LLP masses, $\geq 1\text{cm} - 1\text{m}$	Decays to baryons $\rightarrow$ MATHUSLA likely much greater sensitivity than main detectors. MCFODO	6.1	32
FIMP DM	Freeze-in via decay requires LLPs with SM couplings.	Fixed by masses & cosmology. Long lifetimes generic.	Model-dependent, but in long-lifetime regime MCFODO.	5.3	27, 28, 21,
Co-decaying DM	Out-of-equilibrium decay of hidden sector LLP determines DM abundance. Also, small portal $\rightarrow$ visible sector LLPs.	For weak scale LLP masses, most of parameter space is long lifetimes.	Depending on model details (production & decay mode), MCFODO.	5.4.3	31
Co-annihilating DM	DM relic abundance relies on small mass splitting with another state $\rightarrow$ other state is LLP.	Any, long lifetimes generic.	Depends on model details, but e.g. for Higgs Portal implementations, MCFODO.	5.5	
SUSY: Axinos	High PQ-breaking scale $V_{PQ}$ suppresses axion/axino couplings, making LOSP an LLP	Any, long lifetimes generic.	For high $V_{PQ}$ , MCFODO.	4.1.5	21
SUSY: GMSB	Low SUSY breaking scale $F$ (motivated by flavor problem) leads to light gravitino and small couplings to LOSP, which can hence be LLP.	Any, long lifetimes generic.	MCFODO, depending on spectrum and lifetime.	4.1.2	15
SUSY: RPV	small RPV couplings (motivated by avoiding flavor violation, proton decay, baryon washout) $\rightarrow$ LOSP can be LLP	Any, long lifetimes generic.	MCFODO, especially for EW-charged LSPs or squeezed spectra.	4.1.1	14

# I) intrinsic

BSM Scenario	Role of LLPs	Typical $c\tau$	Role of MATHUSLA	Sec.	Fig.
Neutral Naturalness	Discrete symmetry stabilizing Higgs mass $\rightarrow$ Hidden Valley with Higgs portal. Cosmology $\rightarrow$ HV particles are LLPs.	Any, but $\mathbb{Z}_2$ arguments favor lower $\hat{\Lambda}_{QCD}$ and hence long lifetimes.	Mirror glueballs with long lifetimes can only be discovered at MATHUSLA.	4.2	22, 23
WIMP Baryogenesis	Out-of-equilibrium decay of WIMP-like LLP produces baryon asymmetry.	For weak-scale LLP masses,	Decays to baryons $\rightarrow$ MATHUSLA likely much greater sensitivity than main detectors. MCFODO	6.1	32

mirror glueballs from Higgs decays

mirror neutrinos from Higgs decays that cause asymmetric reheating

- (MS)x(MS or IT)    ■ (VBF  $h \rightarrow bb$ ) x (IT,  $r > 4\text{cm}$ )
- (1 lepton) x (IT,  $r > 50\mu\text{m}$ )    ■ MATHUSLA    ■ TLEP  $Br(h \rightarrow \text{invis})$

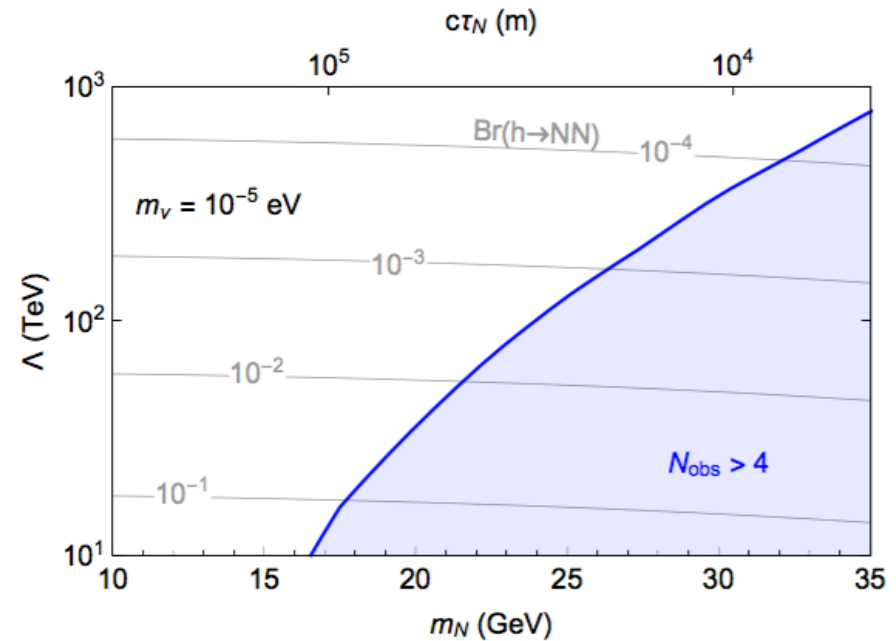
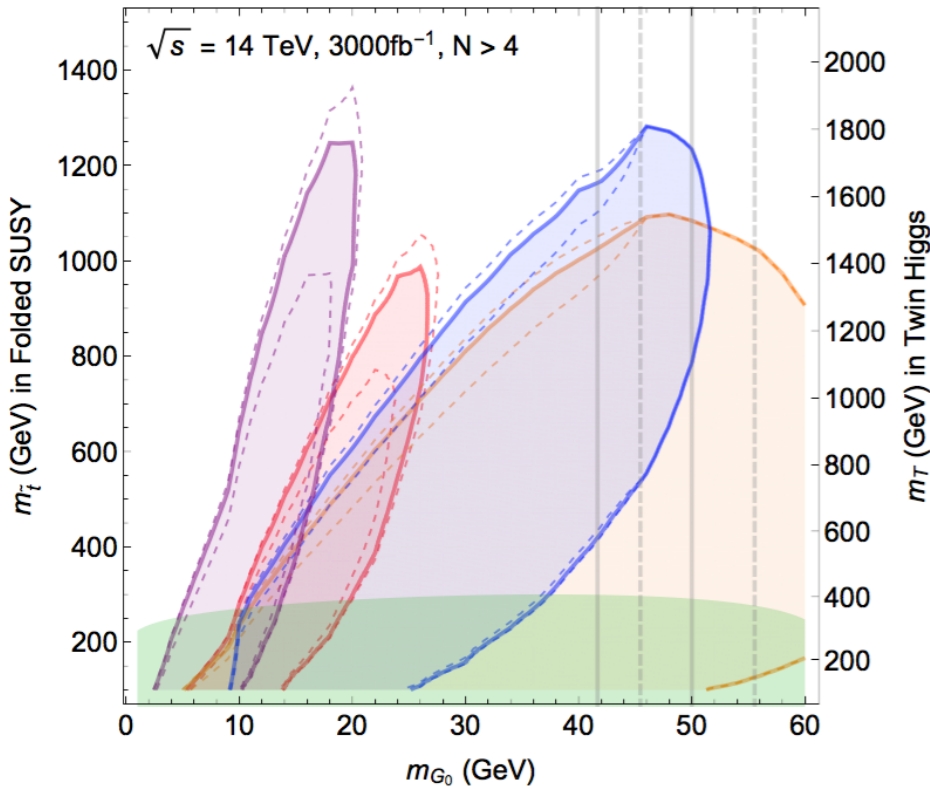

# I) intrinsic

BSM Scenario	Role of LLPs	Typical $c\tau$	Role of MATHUSLA	Sec.	Fig.
Neutral Naturalness	Discrete symmetry stabilizing Higgs mass $\rightarrow$ Hidden Valley with Higgs portal. Cosmology $\rightarrow$ HV particles are LLPs.	Any, but $Z_2$ arguments favor lower $\hat{\Lambda}_{QCD}$ and hence long lifetimes.	Mirror glueballs with long lifetimes can only be discovered at MATHUSLA.	4.2	22, 23
<b>WIMP Baryogenesis</b>	<b>Out-of-equilibrium decay of WIMP-like LLP produces baryon asymmetry.</b>	For weak-scale LLP masses, $\approx 1\text{cm} - 1\text{m}$	Decays to baryons $\rightarrow$ MATHUSLA likely much greater sensitivity than main detectors. MCFODO	<b>6.1</b>	<b>32</b>
FIMP DM	Freeze-in via decay requires LLPs with SM couplings.	Fixed by masses & cosmology. Long lifetimes generic.	Model-dependent, but in long-lifetime regime MCFODO.	5.3	27, 28, 21,
Co-decaying DM				5.4.3	31
Co-annihilating DM				5.5	
SUSY: Axinos				4.1.5	21
SUSY: GMSB				4.1.2	15
SUSY: RPV				4.1.1	14

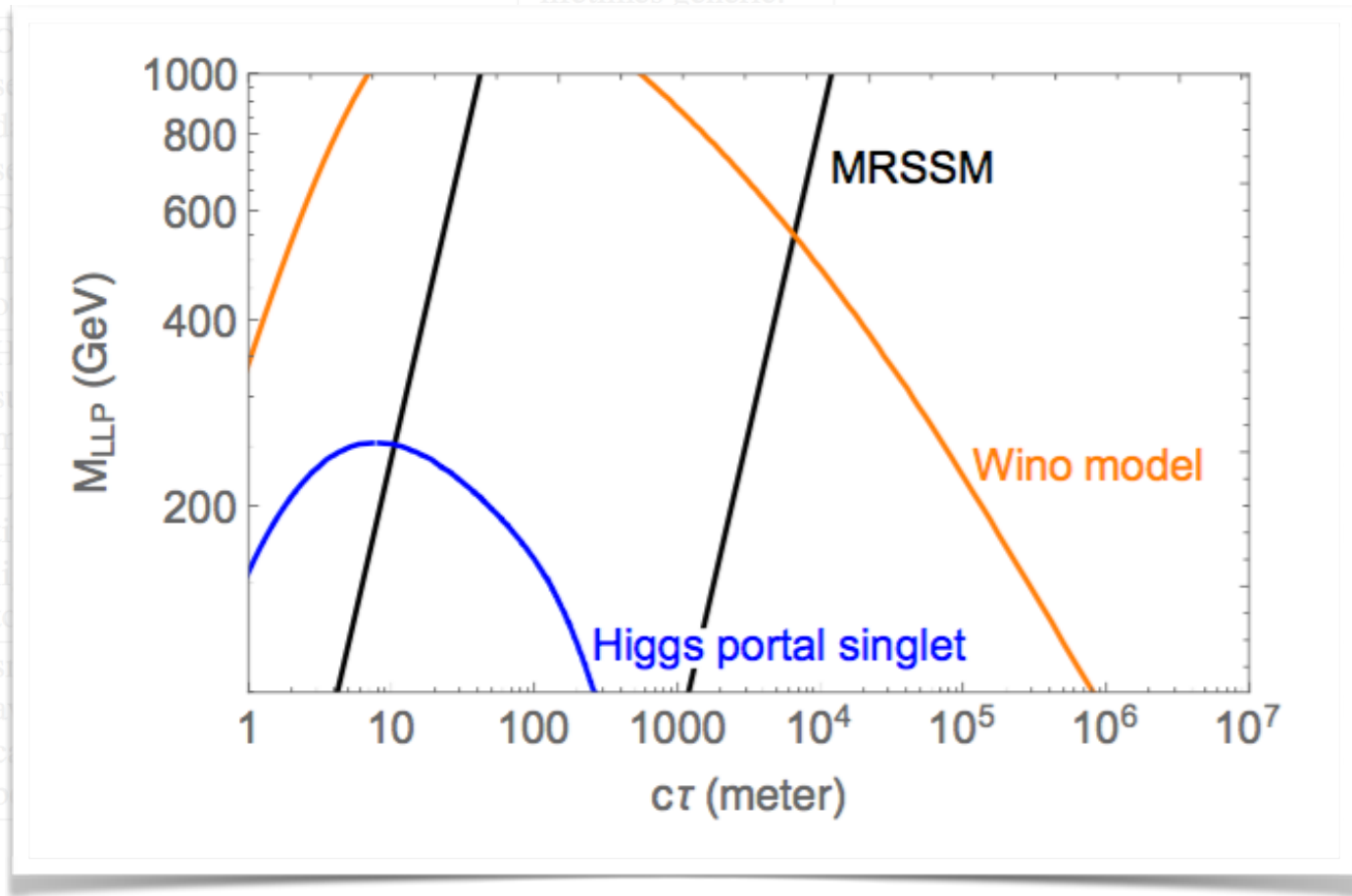

# I) intrinsic

BSM Scenario	Role of LLPs	Typical $c\tau$	Role of MATHUSLA	Sec.	Fig.
Neutral Naturalness	Discrete symmetry stabilizing Higgs mass $\rightarrow$ Hidden Valley with Higgs portal. Cosmology $\rightarrow$ HV particles are LLPs.	Any, but $\mathbb{Z}_2$ arguments favor lower $\hat{\Lambda}_{QCD}$ and hence long lifetimes.	Mirror glueballs with long lifetimes can only be discovered at MATHUSLA.	4.2	22, 23
WIMP Baryogenesis	Out-of-equilibrium decay of WIMP-like LLP produces baryon asymmetry.	For weak-scale LLP masses, $\gtrsim 1-100$ m.	Decays to baryons $\rightarrow$ MATHUSLA likely much greater sensitivity than main detectors. MCFODO	6.1	32
<b>FIMP DM</b>	<b>Freeze-in via decay requires LLPs with SM couplings.</b>	<b>Fixed by masses &amp; cosmology. Long lifetimes generic.</b>	<b>Model-dependent, but in long-lifetime regime MCFODO.</b>	<b>5.3</b>	<b>27, 28, 21,</b>
Co-decaying DM	Out-of-equilibrium decay of hidden sector LLP determines DM abundance. Also, small portal $\rightarrow$ visible sector LLPs.	For weak scale LLP masses, most of parameter space is long lifetimes.	Depending on model details (production & decay mode), MCFODO.	5.4.3	31
Co-annihilating DM	DM relic abundance relies on small mass splitting with another state $\rightarrow$ other state is LLP.	Any, long lifetimes generic.	Depends on model details, but e.g. for Higgs Portal implementations, MCFODO.	5.5	
<b>SUSY: Axinos</b>	<b>High PQ-breaking scale <math>V_{PQ}</math> suppresses axion/axino couplings, making LOSP an LLP</b>	<b>Any, long lifetimes generic.</b>	<b>For high <math>V_{PQ}</math>, MCFODO.</b>	<b>4.1.5</b>	<b>21</b>
<b>SUSY: GMSB</b>	<b>Low SUSY breaking scale <math>F</math> (motivated by flavor problem) leads to light gravitino and small couplings to LOSP, which can hence be LLP.</b>	<b>Any, long lifetimes generic.</b>	<b>MCFODO, depending on spectrum and lifetime.</b>	<b>4.1.2</b>	<b>15</b>
SUSY: RPV	small RPV couplings (motivated by avoiding flavor violation, proton decay, baryon washout) $\rightarrow$ LOSP can be LLP	Any, long lifetimes generic.	MCFODO, especially for EW-charged LSPs or squeezed spectra.	4.1.1	14

# I) intrinsic

BSM Scenario	Role of LLPs	Typical $\tau$
Neutral Naturalness	Discrete symmetry stabilizing Higgs mass $\rightarrow$ Hidden Valley with Higgs portal. Cosmology $\rightarrow$ HV particles are LLPs.	Any, but $\tau$ depends on $\Lambda_{QCD}$ and long lifetime
WIMP Baryogenesis	Out-of-equilibrium decay of WIMP-like LLP produces baryon asymmetry.	For $\tau$ $\gtrsim 1-100$
FIMP DM	Freeze-in via decay requires LLPs with SM couplings.	Fixed by cosmological lifetimes
Co-decaying DM	Out-of-equilibrium decay of hidden sector LLP determines DM abundance. Also, small portal couplings to SM.	For $\tau$ $\gtrsim 10^2$ LLP mass $\gtrsim 100$ GeV
Co-annihilating DM	DM relic abundance $\rightarrow$ mass splitting with another state is LLP.	
SUSY: Axinos	High PQ-breaking suppresses axion/axino making LOSP an LLP	
SUSY: GMSB	Low SUSY breaking motivated by flavor problem light gravitino and staus to LOSP, which can be LLP	
SUSY: RPV	small RPV couplings avoiding flavor violation, baryon washout) can be LLP	

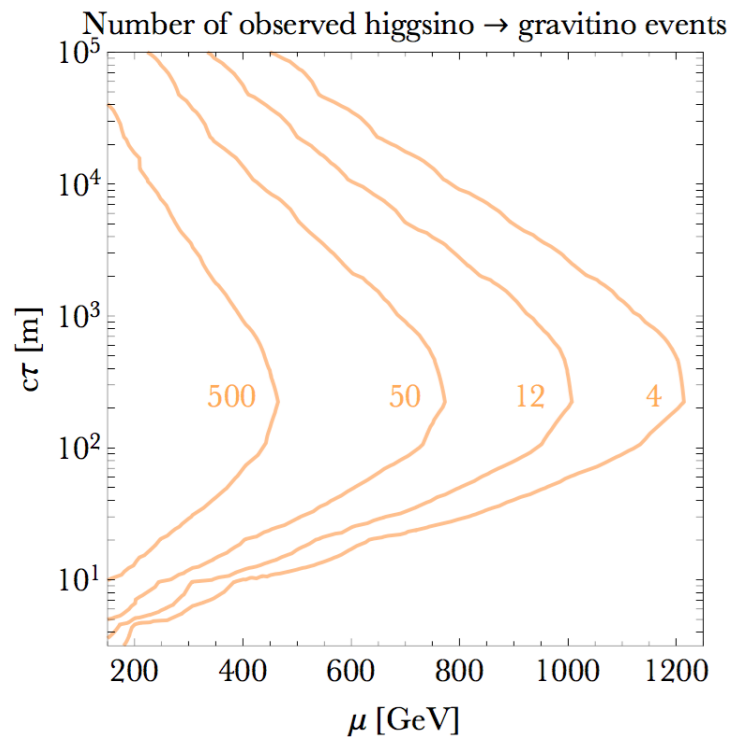
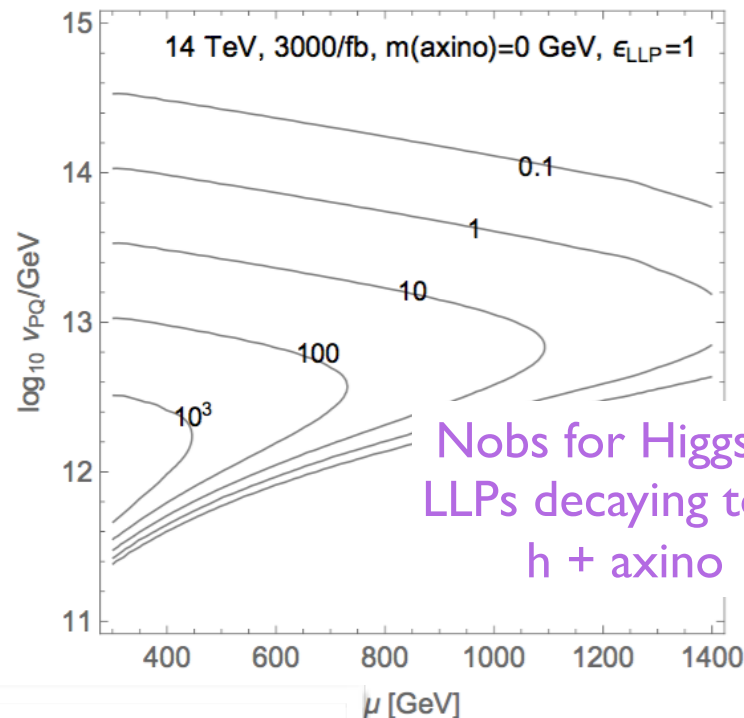

Model details, but e.g. implementations,	5.5	
MFODO.	4.1.5	21
depending on spectrum	4.1.2	15
especially for EW-squeezed spectra.	4.1.1	14

# I) intrinsic

BSM Scenario	Role of LLPs	Typical $c\tau$	Role of MATHUSLA	Sec.	Fig.
Neutral Naturalness	Discrete symmetry stabilizing Higgs mass $\rightarrow$ Hidden Valley with Higgs portal. Cosmology $\rightarrow$ HV particles are LLPs.	Any, but $Z_2$ arguments favor lower $\hat{\Lambda}_{QCD}$ and hence long lifetimes.	Mirror glueballs with long lifetimes can only be discovered at MATHUSLA.	4.2	22, 23

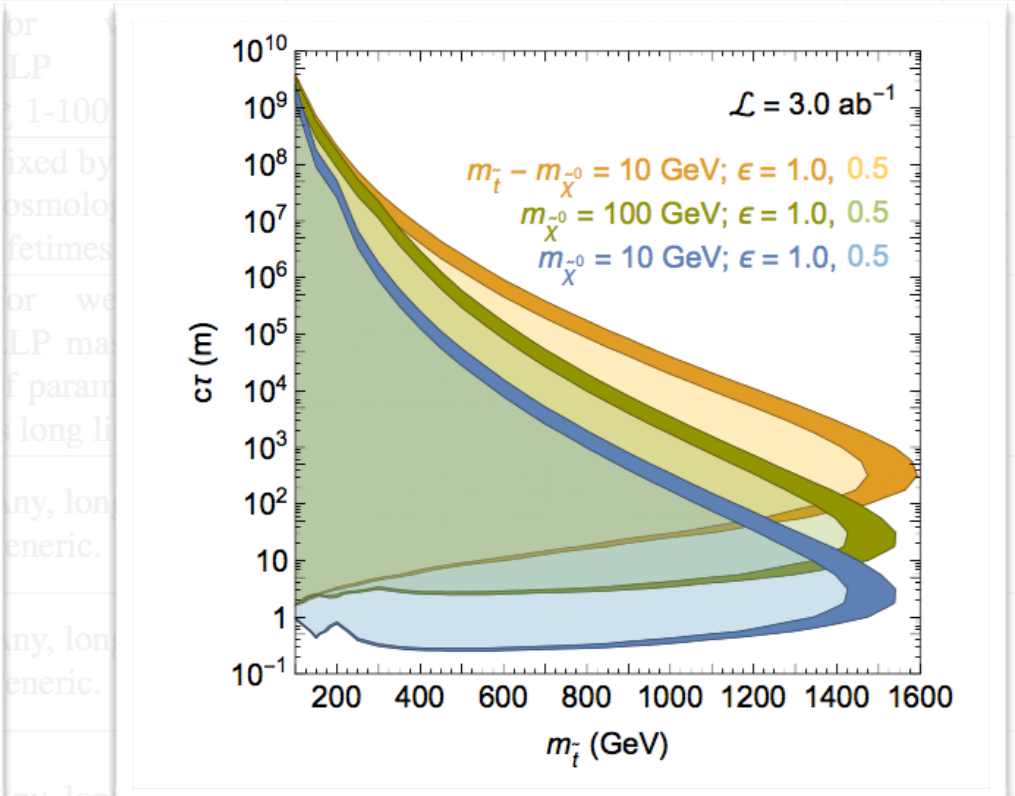
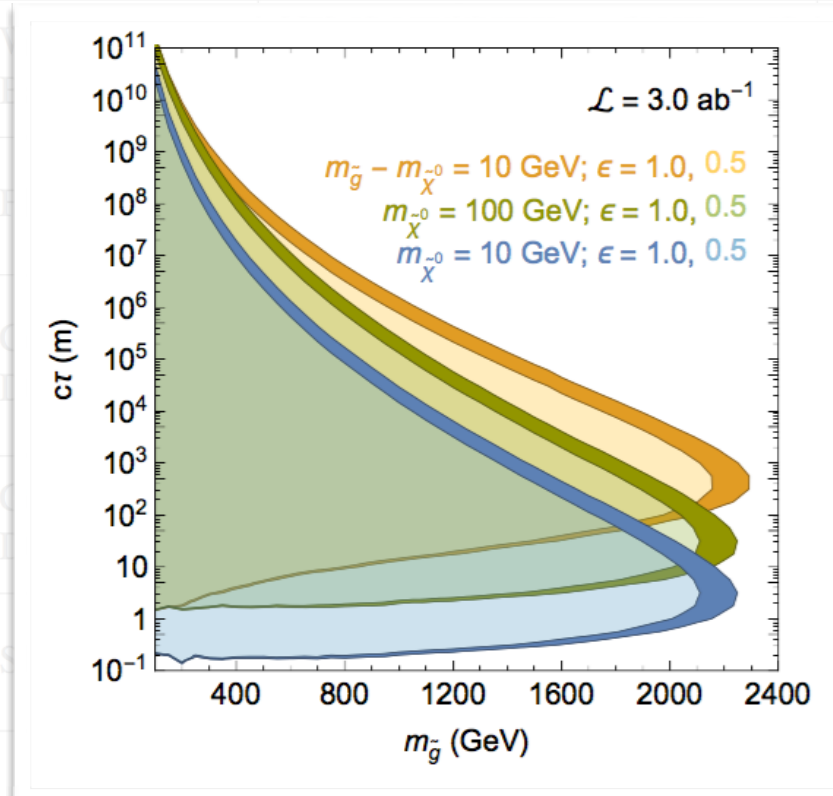

SUSY: GMSB	light gravitino and small couplings to LOSP, which can hence be LLP.	Any, long lifetimes generic.	and lifetime.	4.1.2	13
------------	--	------------------------------	---------------	-------	----

SUSY: RPV	small RPV couplings (motivated by avoiding flavor violation, proton decay, baryon washout) $\rightarrow$ LOSP can be LLP	Any, long lifetimes generic.	MCFODO, especially for EW-charged LSPs or squeezed spectra.	4.1.1	14
-----------	--	------------------------------	---	-------	----

# I) intrinsic

SUSY: Sgoldstinos	SUSY breaking scale $F$ suppresses sgoldstino coupling to supercurrents $\rightarrow$ can be LLP.	Any. Long lifetimes $\rightarrow$ smallest production, hardest to probe.	Similar to SM+S. For masses $\lesssim 5$ GeV, MATHUSLA and/or SHiP may be only/first discovery opportunity.	4.1.6	
minimal RH neutrino model	Type-1 see-saw $\rightarrow$ tiny mixing between $\nu_L$ and $\nu_R \rightarrow \nu_R$ LLPs	Any, long lifetimes favor lower $m_{\nu_R}$	In long-lifetime/low-mass regime, MATHUSLA and/or SHiP may be only/first discovery opportunity.	7.1	34, 35

$\rightarrow$ with $U(1)$	Weakly gauged $B-L$ breaking gen-	$m_{\nu_R} \sim 1-10$ GeV	For sub-weak-scale $m_{\nu_R}$ ,	7.2.1	36
$\rightarrow$ $SU(2)$			10 TeV: main es weak-scale $m_{\nu_R}$ ; SHiP only discovery for $m_{\nu_R} \lesssim 5$ GeV.	7.3.1	38
$\rightarrow$ Higgs			improves Br reach of s by at least order of	7.4	41
$m_\nu$ sym			EW charge $\rightarrow$ especially for	7.5	

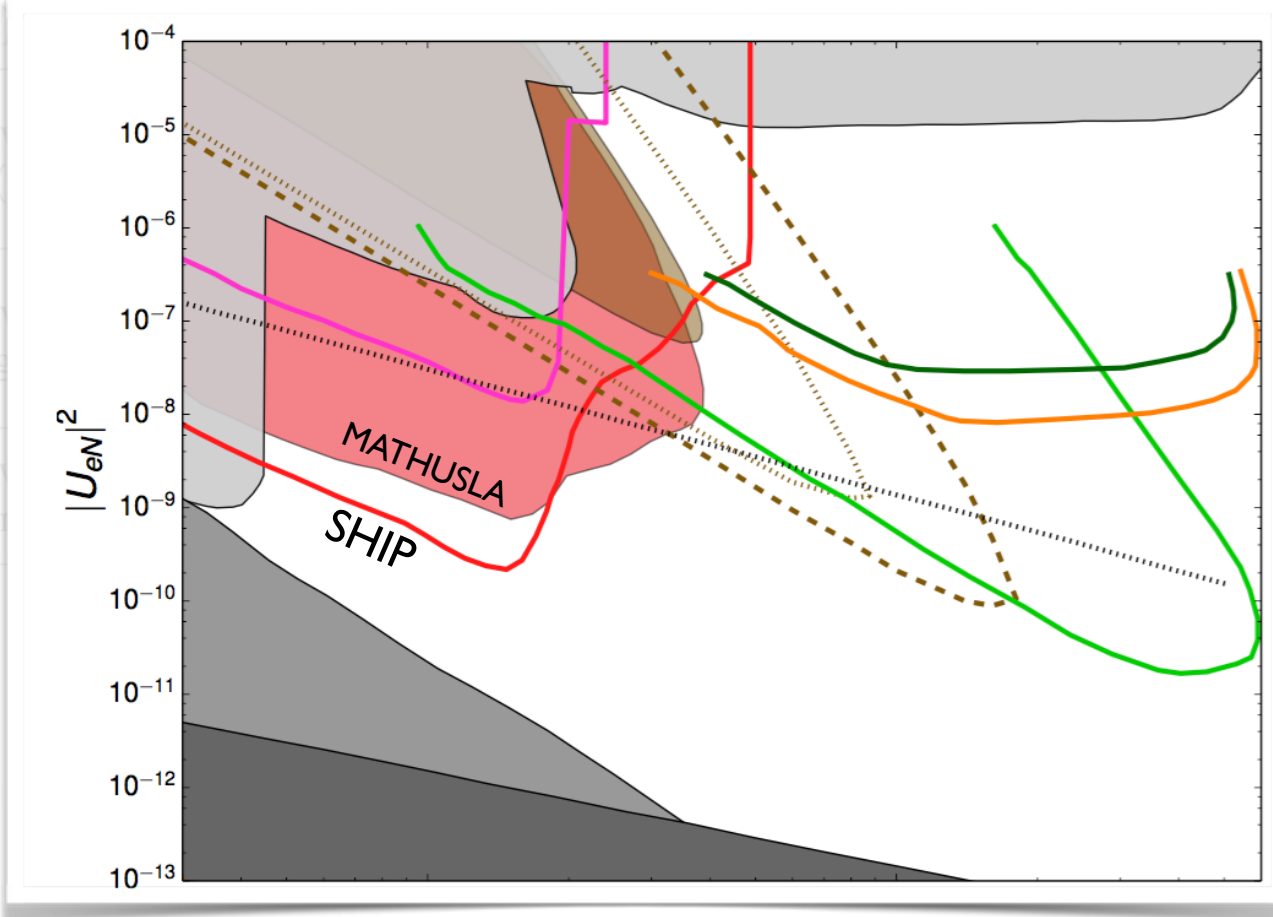

MATHUSLA are a strongly only Discovery Opportunity is the MATHUSLA regime.

## 2) generic

BSM Scenario	Role of LLPs	Typical $c\tau$	Role of MATHUSLA (long $c\tau$ )	Sec.	Fig.
Hidden Valleys (HV)	Small portal to visible sector and possibly hidden sector confinement $\rightarrow$ meta-stable states.	Any.	MCFODO, especially if LLPs are significantly below the weak scale or decay hadronically.	8.1	44, 45
SM+S	Small mixing $\rightarrow$ scalar LLP for $m_S < 2m_H$ . Large mixing $\rightarrow$ $S$ could decay to HV LLPs.	Any.	MCFODO. Complementarity with SHiP.	8.4	52
SM+V	Dark photon/dark Higgs LLP could be produced in exotic Higgs/ $Z$ decays. Dark photon with non-tiny kinetic mixing could be copiously produced at LHC and decay to HV LLPs.	Any.	MCFODO. Significantly extends main detector long-lifetime reach for dark photons and dark Higgs produced in exotic $H$ and $Z$ decays. For LLPs produced in dark photon decays, see HV.	8.5	56, 58, 60, ??
Exotic Higgs decays	Higgs coupling to new states, like HV or other LLPs, is highly generic and leads to large production rates at LHC.	Any.	MCFODO for $\text{Br} \lesssim 0.1 - 0.01$ . Higgs portal motivates hadronic LLP decays, for which MATHUSLA has $10^3$ better Br reach than main detectors. MATHUSLA also has significantly better sensitivity for LLP masses $\lesssim 10$ GeV even if they decay leptonically, or for LLPs with subdominant leptonic decays.	8.2	46, 47
Asymmetric DM	Relating DM to baryon abundance requires operator connecting DM number and Baryon/Lepton number $\rightarrow$ higher dimensional operator $\rightarrow$ LLPs	Any, depending on kind and scale of physics generating the operator.	MCFODO (highly dependent on production and decay mode).	5.1	
Dynamical DM	DM sector includes spectrum of states with varying life-time up to highly stable DM.	Any, long lifetimes generic in DM sector spectrum.	MCFODO (highly dependent on production and decay mode).	5.2	[DC, TB]



# 2) generic

BSM Scenario	Role of LLPs	Typical $c\tau$	Role of MATHUSLA (long $c\tau$ )	Sec.	Fig.
Hidden Valleys (HV)	Small portal to visible sector and possibly hidden sector confinement $\rightarrow$ meta-stable states.	Any.	MCFODO, especially if LLPs are significantly below the weak scale or decay hadronically.	8.1	44, 45
SM+S	Small mixing $\rightarrow$ scalar LLP for $m_S < 2m_H$ . Large mixing $\rightarrow$ $S$ could decay to HV LLPs.	Any.	MCFODO. Complementarity with SHiP.	8.4	52

Dark photon/dark Higgs LLP could be produced in exotic Higgs/Z de-

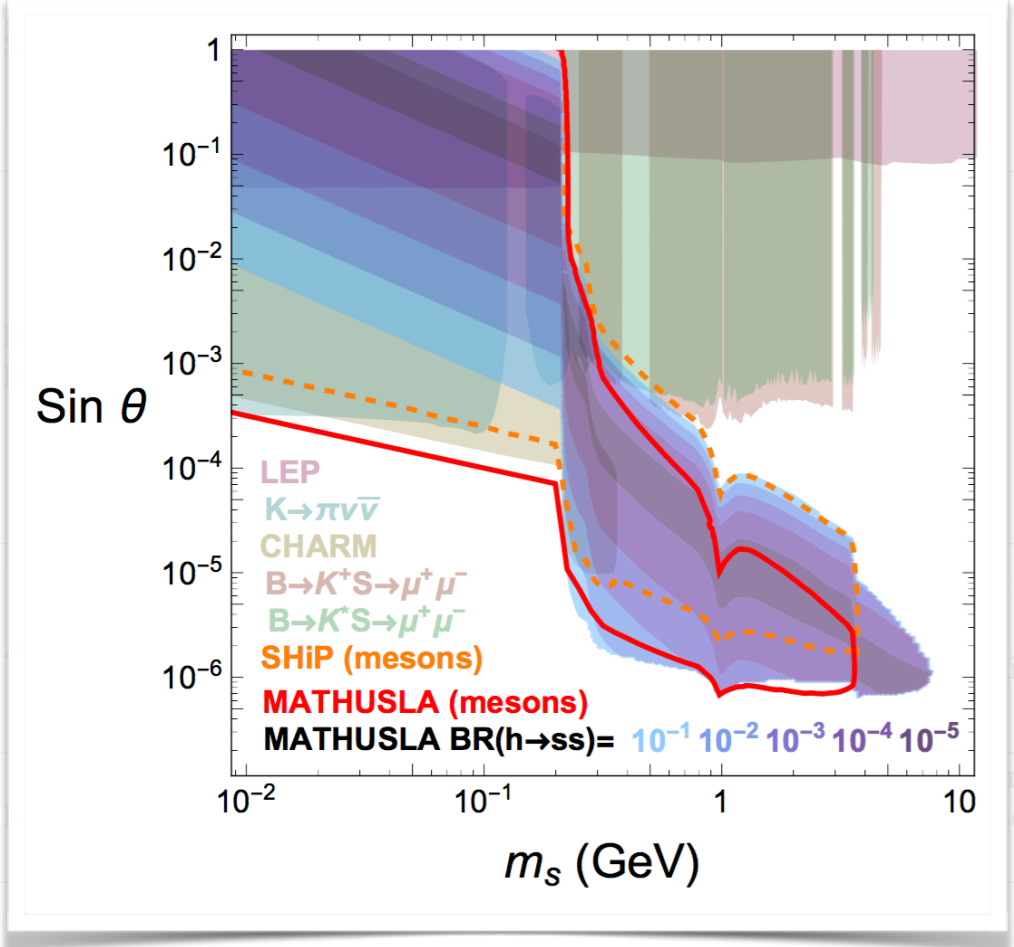

MCFODO. Significantly extends main detector long-lifetime reach for dark photons and dark Higgs produced in exotic  $H$  and  $Z$  decays. For LLPs produced in dark photon decays, see HV.

MCFODO for  $Br \lesssim 0.1 - 0.01$ . Higgs portal motivates hadronic LLP decays, for which MATHUSLA has  $10^3$  better  $Br$  reach than main detectors. MATHUSLA also has significantly better sensitivity for LLP masses  $\lesssim 10$  GeV even if they decay leptonically, or for LLPs with subdominant leptonic decays.

on of ing MCFODO (highly dependent on production and decay mode).

nes ec- MCFODO (highly dependent on production and decay mode).

## 2) generic

Nikita Blinov, Jae Hyeok Chang, David Curtin, Rouven Essig, Brian Shuve

BSM Scenario	Role of LLPs	Typical $c\tau$	Role of MATHUSLA (long $c\tau$ )	Sec.	Fig.
Hidden Valleys (HV)	Small portal to visible sector and possibly hidden sector confinement $\rightarrow$ meta-stable states.	Any.	MCFODO, especially if LLPs are significantly below the weak scale or decay hadronically.	8.1	44, 45
SM+S	Small mixing $\rightarrow$ scalar LLP for $m_S < 2m_H$ . Large mixing $\rightarrow$ $S$ could decay to HV LLPs.	Any.	MCFODO. Complementarity with SHiP.	8.4	52
SM+V	Dark photon/dark Higgs LLP could be produced in exotic Higgs/ $Z$ decays. Dark photon with non-tiny kinetic mixing could be copiously produced at LHC and decay to HV LLPs.	Any.	MCFODO. Significantly extends main detector long-lifetime reach for dark photons and dark Higgs produced in exotic $H$ and $Z$ decays. For LLPs produced in dark photon decays. see HV.	8.5	56, 58, 60, ??
Exotic Higgs decays	Higgs coupling to new states, like HV or other LLPs, is highly generic and leads to large production rates at LHC.	Any.	MCFODO for $\text{Br} \lesssim 0.1 - 0.01$ . Higgs portal motivates hadronic LLP decays, for which MATHUSLA has $10^3$ better Br reach than main detectors. MATHUSLA also has significantly better sensitivity for LLP masses $\lesssim 10$ GeV even if they decay leptonically, or for LLPs with subdominant leptonic decays.	8.2	46, 47
Asymmetric DM	Relating DM to baryon abundance requires operator connecting DM number and Baryon/Lepton number $\rightarrow$ higher dimensional operator $\rightarrow$ LLPs	Any, depending on kind and scale of physics generating the operator.	MCFODO (highly dependent on production and decay mode).	5.1	
Dynamical DM	DM sector includes spectrum of states with varying life-time up to highly stable DM.	Any, long lifetimes generic in DM sector spectrum.	MCFODO (highly dependent on production and decay mode).	5.2	[DC's TB]

# 2) generic

Nikita Blinov, Jae Hyeok Chang, David Curtin, Rouven Essig, Brian Shuve

BSM Scenario	Role of LLPs
Hidden Valleys (HV)	Small portal to visible sector possibly hidden sector containing meta-stable states.
SM+S	Small mixing $\rightarrow$ scalar $m_S < 2m_H$ . Large mixing could decay to HV LLPs.
SM+V	Dark photon/dark Higgs LLP could be produced in exotic Higgs/Z decays. Dark photon with non-tiny kinetic mixing could be copiously produced at LHC and decay to HV LLPs.

long-lived dark higgs production in exotic Z decays

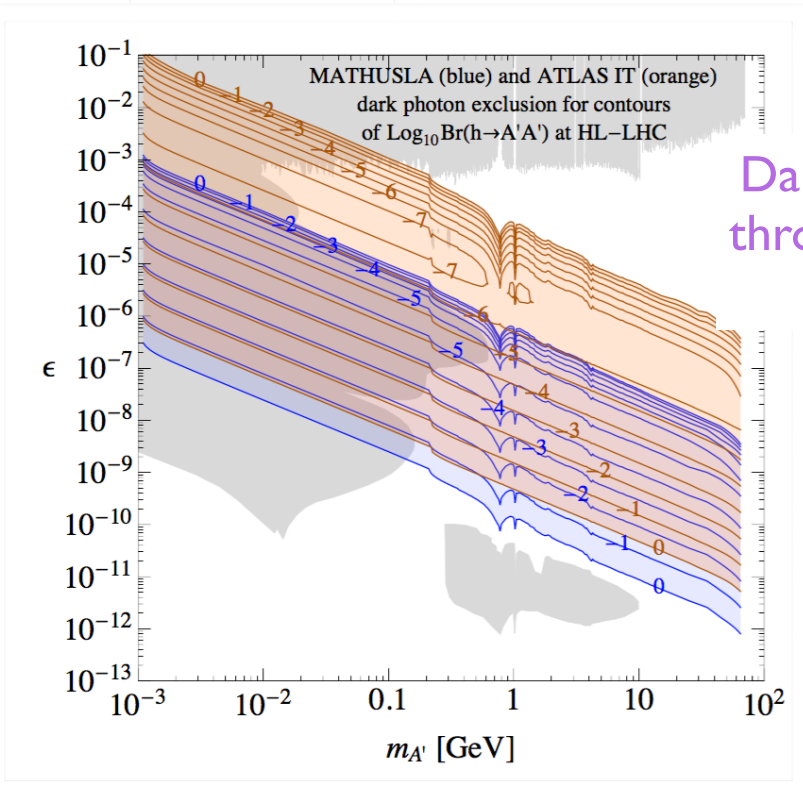
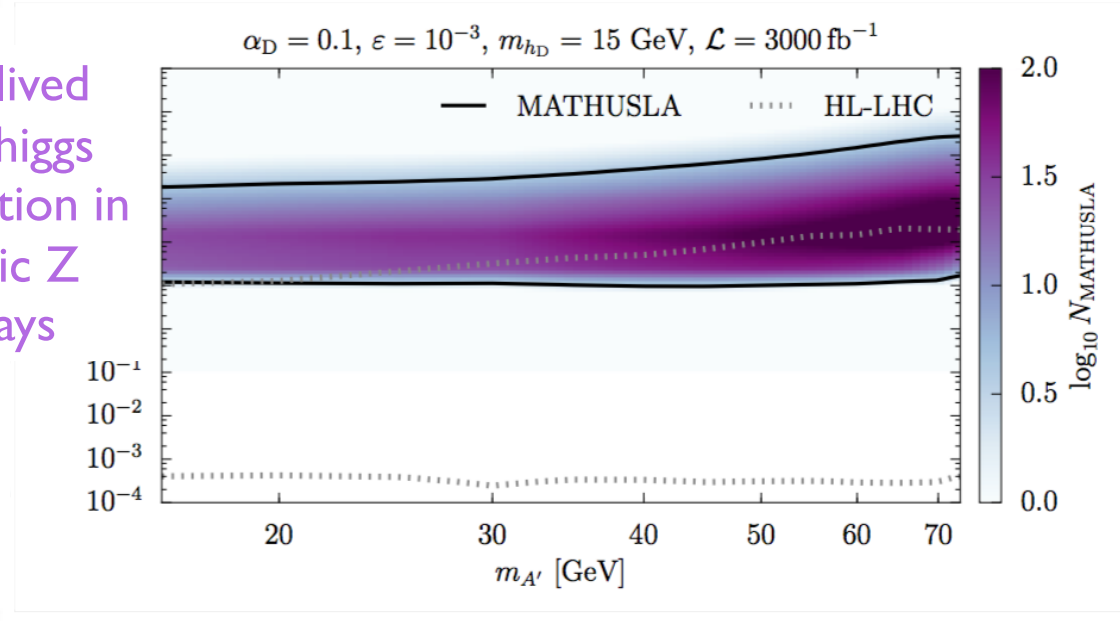

Dark photon through Higgs portal

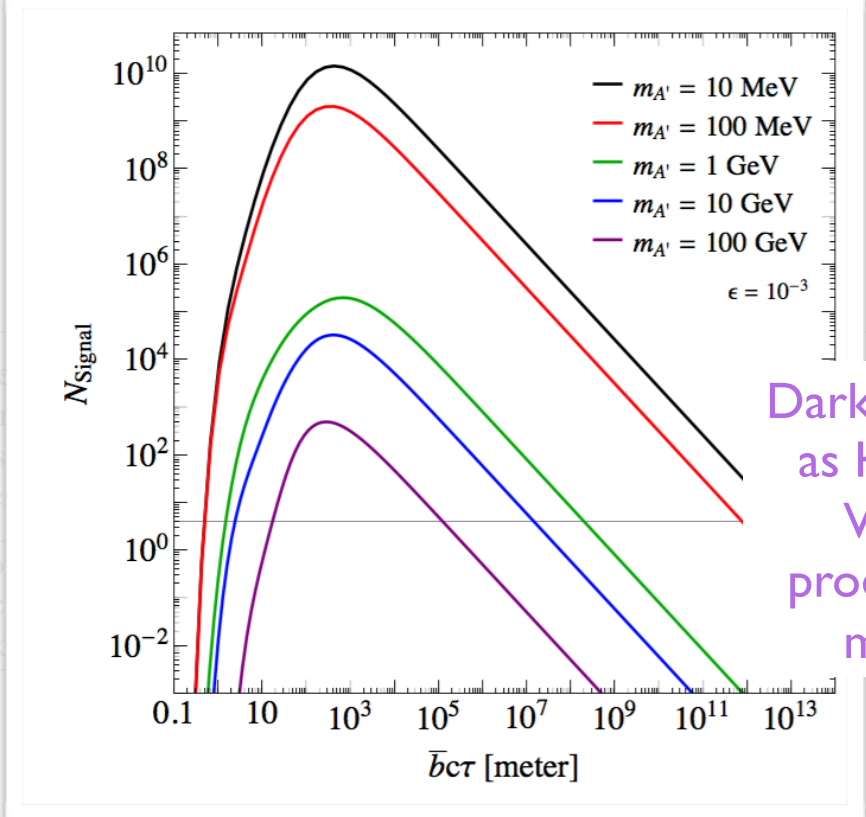

Dark photon as Hidden Valley production mode

## 2) generic

SIMP/ELDER DM	Strong dynamics of HV generate DM abundance. $HV \rightarrow$ LLPs.	Any.	See HV.	5.4.1, 5.4.2	
Relaxion	Relaxion or other new scalars in theory generically mix with Higgs $\rightarrow$ SM+S.	Any.	See SM+S.	4.4	
Axion-like particles	ALP couplings to $h$ and $Z$ are generic in EFT framework. $1/f$ suppression makes ALP an LLP.	Any.	MCFODO for low-scale $f$ .	8.6	63, 64, 65, 66, 67
Leptogenesis	Motivates minimal RH neutrino model and other neutrino extensions, which generically feature LLPs.	Any, long lifetimes favor lower $m_{\nu_R}$ .	Generally very difficult to probe, especially at high leptogenesis scale. In long-lifetime/low-mass regime, MATHUSLA and/or SHiP may be only/first discovery opportunity.	6.2	
Scalars in neutrino extensions	Gauge extensions in neutrino models give rise to new scalars that can mix with Higgs $\rightarrow$ SM+S. Also provides additional $S$ production modes via heavy gauge boson decay.	Any.	See SM+S, with some additional production modes (new heavy gauge bosons).	7.2.2, 7.3.2	

# 5. Bonus: Cosmic Ray Physics

# Cosmic Ray Physics @ MATHUSLA

MATHUSLA is an excellent Cosmic Ray Telescope!

Has unique abilities in CR experimental ecosystem  
(precise resolution, full coverage of its area)

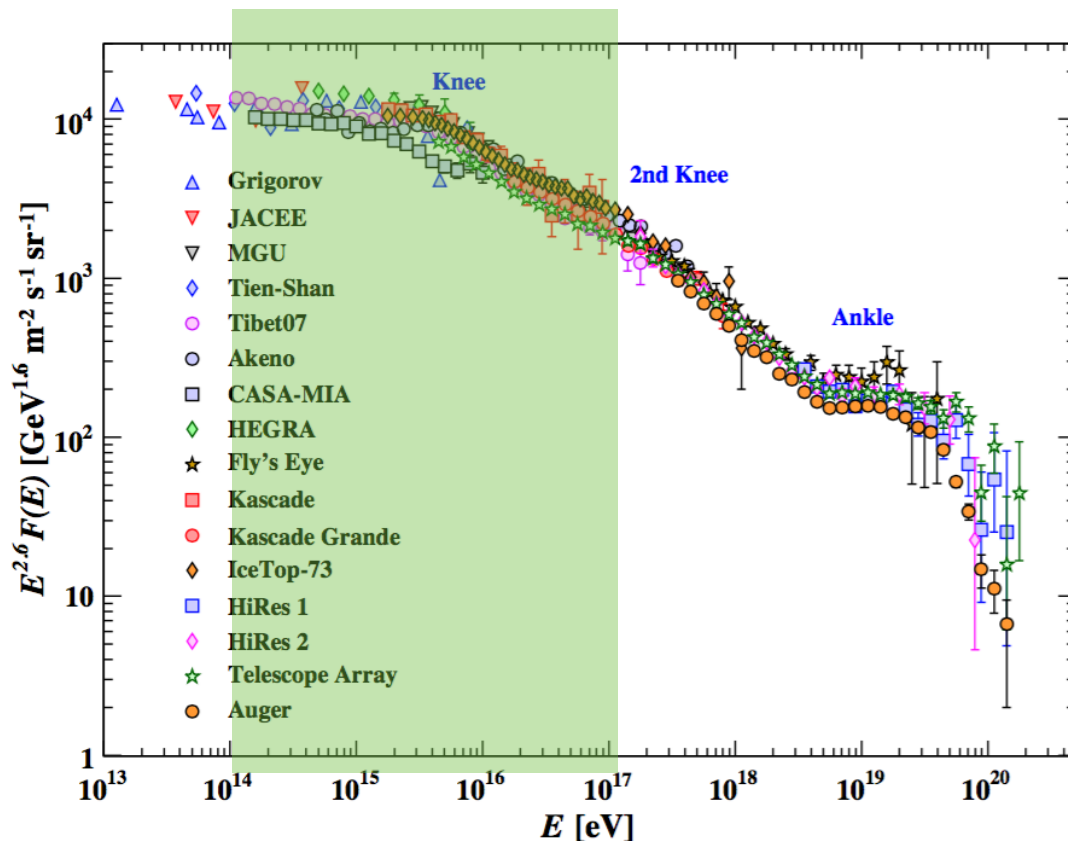

~90% e, ~10%  $\mu$ , less hadrons

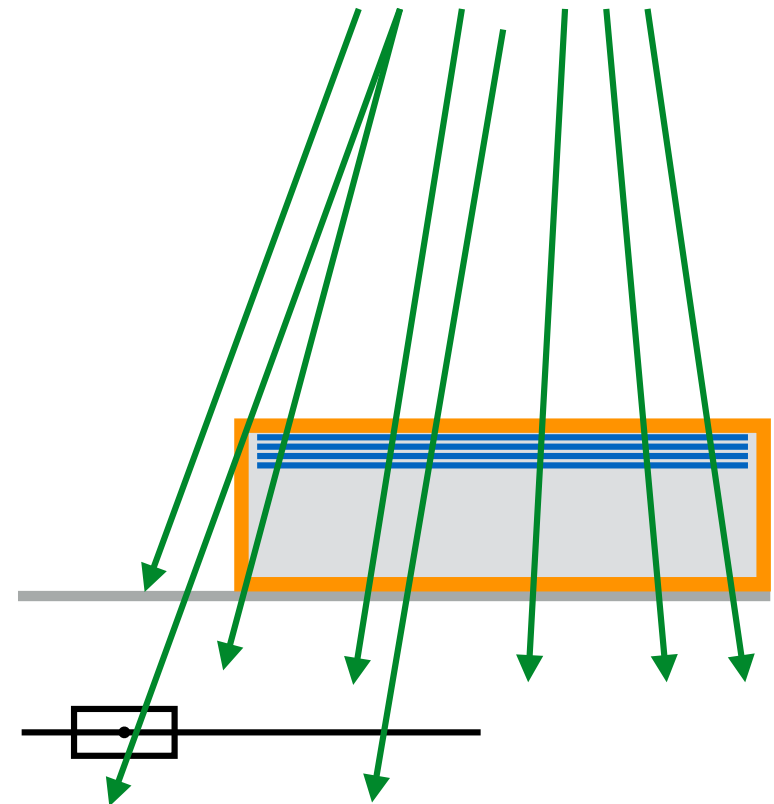

# Cosmic Ray Physics @ MATHUSLA

Primary Cosmic Ray spectra and composition

Cosmic Ray Anisotropies at PeV energies

Highly inclined Showers:

electron/photon-depleted, mostly muons.

Probe various shower parameters (attenuation length etc).

Probe neutrino production in atmosphere or Jura mountains (!)

Study of extended air showers, including precise spatial-temporal structure, to help develop hadron interaction models, important for all CR experiments

High-Multiplicity Muon Bundles, observed at LEP & ALICE, point to either Iron-rich CRs around knee (or BSM ???)

**Guaranteed Physics Return!**

# 6. Timeline



# MATHUSLA Timeline

This year:

**Theory LLP white paper** released June 2018

**Cosmic Ray white paper** released mid-2018

currently working on **Letter of Intent**, finalize at dedicated collaboration meeting August 2018

**Report of the PBC BSM Subgroup** comparing MATHUSLA/CODEX-b/FASER to ShiP: end of 2018

submit **LOI to CERN/European Strategy** end of 2018

# 7. Conclusion

# Conclusion

The LHC is a unique opportunity to explore the **Lifetime Frontier**, providing both high **energy and high intensity** needed to explore weak-scale LLP physics.

It's evident that **LLP searches are fundamentally and strongly motivated**, for many bottom-up and top-down reasons. Take your pick...  
(and see MATHUSLA white paper)

**Future searches will benefit from systematic roadmap and coordination** (LHC-LLP white paper etc). Fill out the search space!

Many exciting add-on detector proposals.

**MATHUSLA Could be First or Only Discovery Opportunity for lots of BSM scenarios.**

**Making LLPs is the expensive part!**  
**Let's make sure we can actually see them!**



— Thank you! —

# Backup Slides

How does MATHUSLA  
reach the zero-background  
regime?

# Background Rejection (gory details)

Most important part of background rejection is the *\*extremely\** conspicuous, multi-faceted and tightly defined nature of LLP decay signal:

$\Delta t \geq 3.5\text{ns}$  per tracker layer,  
17 ns for all 5 layers  
tracker time resolution: 1ns

$\sim 1\text{m}$   $\updownarrow$

tracks are reconstructed in 3D  
*\*and\** with detailed timing  
information at each layer,  
so DV is really a “4D DV”

Shown is “leptonic” 2-  
body LLP decay.

These requirements  
become exponentially  
more difficult to fake  
when decay is hadronic  
with  $\sim 10$  charged final  
states!

most basic CR rejection: LLP decay products are upwards going tracks!

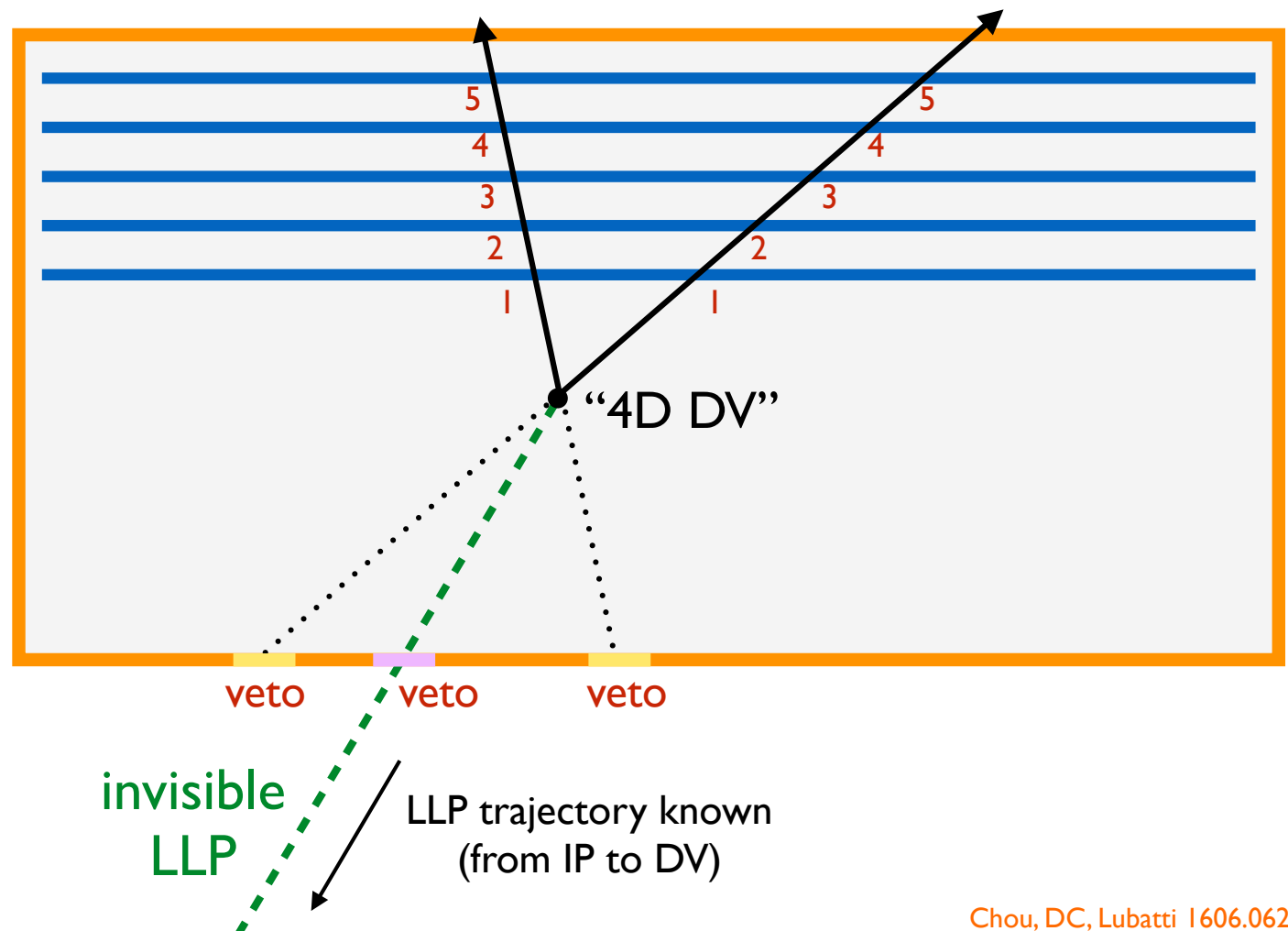

# Background Rejection (gory details)

Most important part of background rejection is the *\*extremely\** conspicuous, multi-faceted and tightly defined nature of LLP decay signal:

$\Delta t \geq 3.5\text{ns}$  per tracker layer,  
17 ns for all 5 layers  
tracker time resolution: 1 ns

$\sim 1\text{m}$   $\updownarrow$

tracks are reconstructed in 3D  
*\*and\** with detailed timing  
information at each layer,  
so DV is really a **“4D DV”**

Like so.

All  $\sim 10$  tracks have to  
meet in both space and  
time at DV and pass vetos  
on floor/walls.

(also, hadronic decay mode is perhaps a bit  
more of a MATHUSLA target due to main  
detector gap in coverage.)

most basic CR rejection: LLP decay products are upwards going tracks!

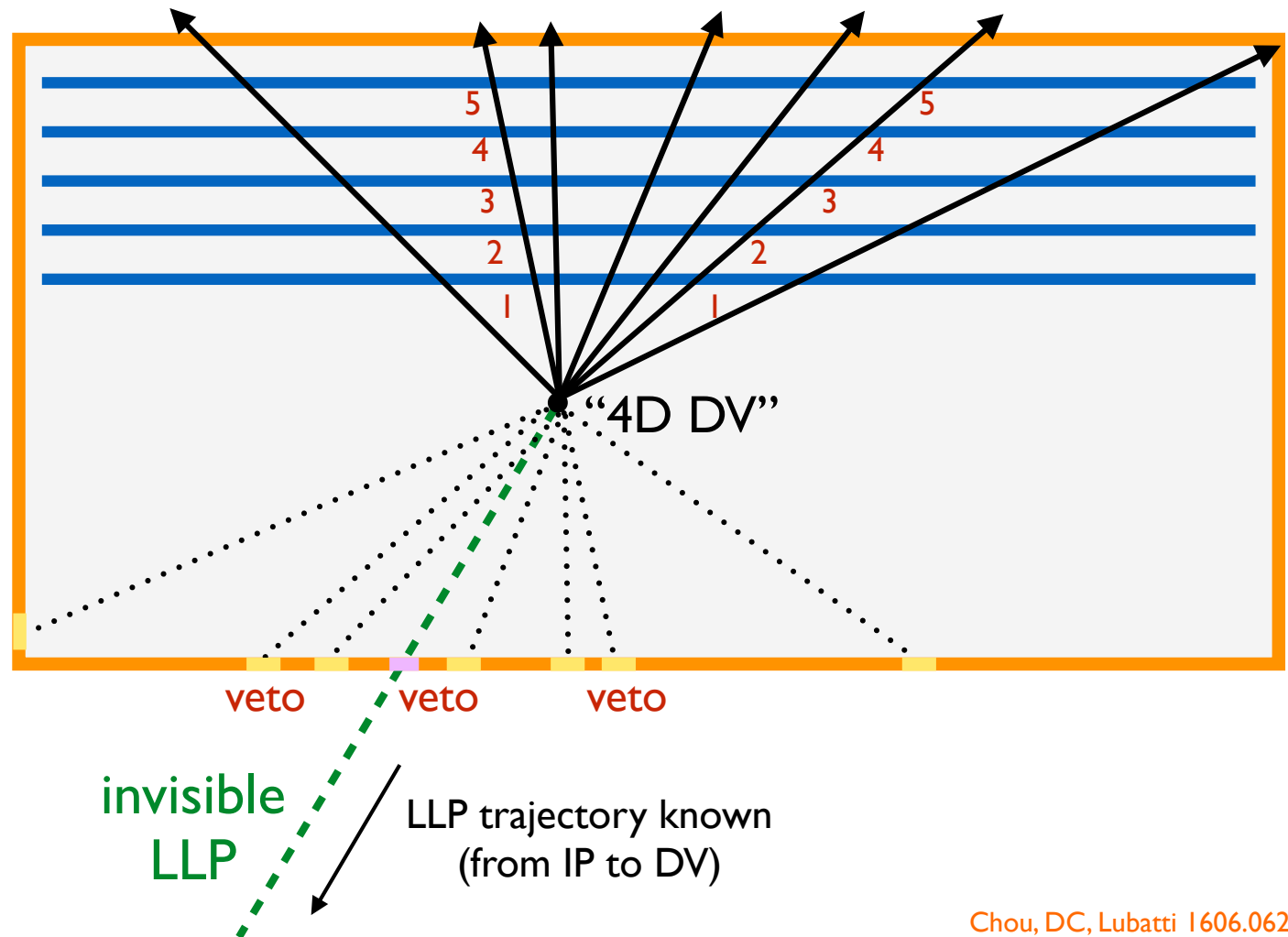



# Background Rejection (gory details)

Compare to Cosmic Rays: about  $10^{15}$  charged particles over HL-LHC run

$\Delta t \geq 3.5\text{ns}$  per tracker layer,  
17 ns for all 5 layers  
tracker time resolution: 1ns

$\sim 1\text{m}$  

For **\*single\*** downward-traveling charged particle from CR, assuming only **\*three\*** layers with 1ns timing resolution within 5m, chance of downward **\*consistently\*** reconstructing as upward going is  $\epsilon_{\text{down} \rightarrow \text{up}} \approx 10^{-15}$

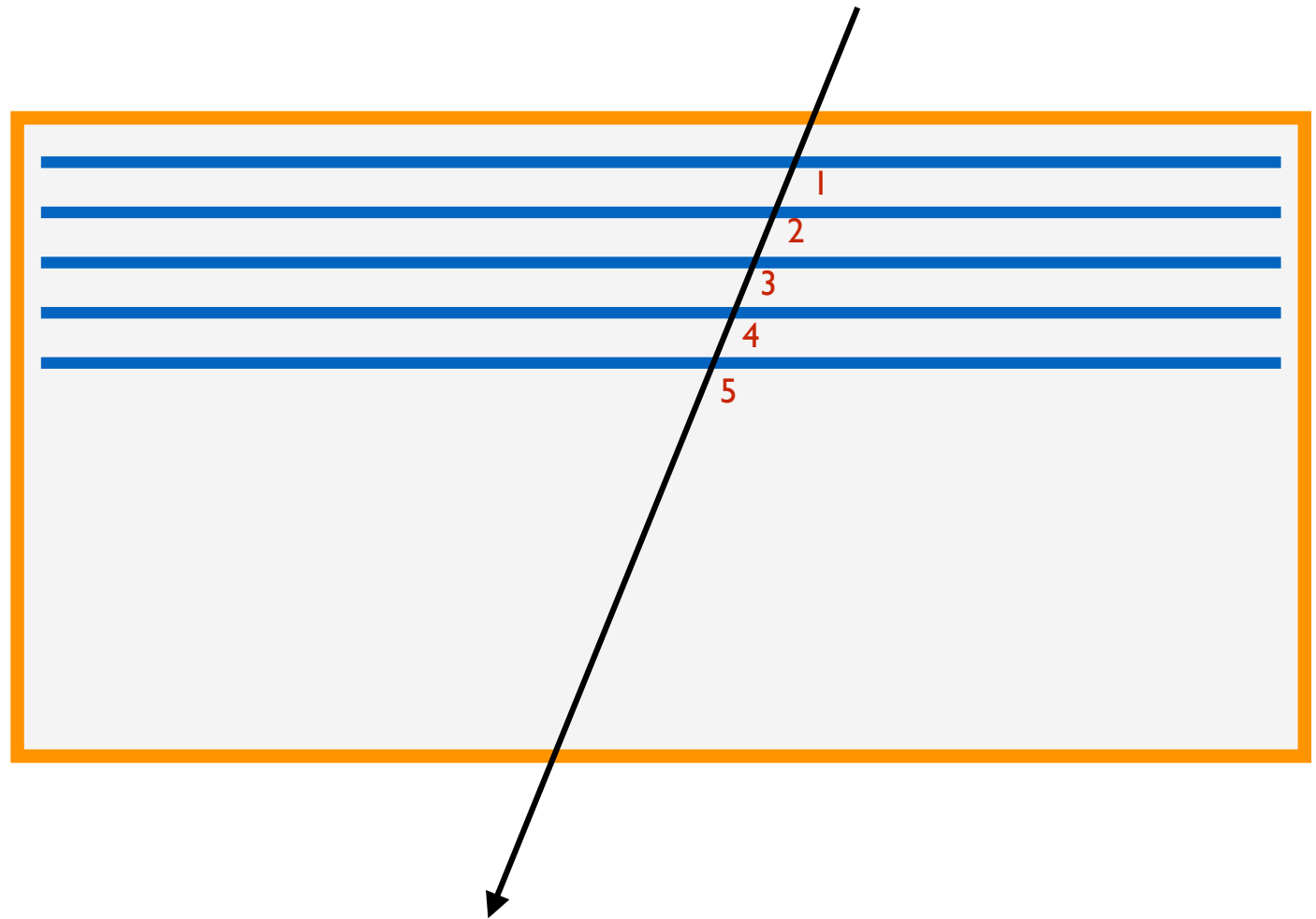

# Background Rejection (gory details)

Com In this naive estimate, simple up-vs-down rejection \*easily\* gets rid of \*all\* cosmic ray backgrounds by itself.

$\Delta t \geq 3$   
17  
tracker Of course, our estimate of  $\epsilon_{\text{down} \rightarrow \text{up}}$  by itself is much too naive, based on purely gaussian time resolution, in reality tails are non-gaussian etc.

But this estimate only used 3 layers. We specified MATHUSLA to have 5.

For \*s Furthermore: single down  $\rightarrow$  up fake does NOT fake the LLP signal. You need:

- **\*two\* down  $\rightarrow$  up fakes** occurring 'at same time' (so  $\epsilon_{\text{down} \rightarrow \text{up}}^2$ )
- they need to **cross in space to form a DV**: requires either spatial mismeasurements (most CRs don't do this) OR very rare CR trajectory crossings
- the huge timing errors made by 5 tracking layers for each track have to be such that the **tracks reconstruct to be coincident \*in time\*** at the fake DV as well
- the **scintillators have to fail to register the two CRs** on their way out of the decay volume.

# Background Rejection (gory details)

Most CR tracks are highly correlated, forming Extensive Air Showers:

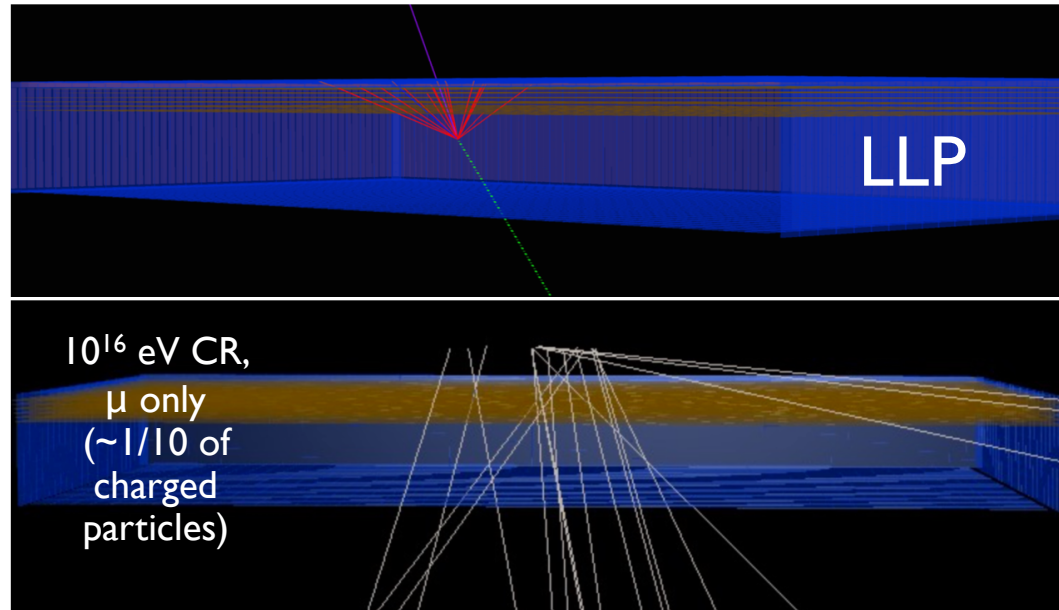

Indeed, these showers are the best chance for all these unlikely things to occur and fake an LLP 4D-DV.

**BUT YOU CAN JUST “BLIND” THE DETECTOR WHILE IT HAS HIGH OCCUPANCY THAT IS OBVIOUSLY FROM A CR SHOWER.**

Blind time has negligible effect on uptime & LLP sensitivity.

Com  
run  
 $\Delta t \geq 3$   
17  
tracker  
For \*s  
tra  
par  
assun  
layers  
resol  
chan  
\*c  
rec  
up  
E<sub>do</sub>

# Background Rejection (gory details)

Com run

$\Delta t \geq 3$   
17  
tracker

There might be very weird things that give rise to DVs in CR events:  
neutron decays, air scatterings of CR particles etc...

These much rarer occurrences will be studied in detail, but again, most of  
them would occur in highly correlated CR showers that are vetoed just  
based on occupancy.

Finally, this CR background is inherently \*studyable\*: during ~50% of time  
when HL-LHC beam is off, you can verify CR rejection strategies on data  
that is guaranteed to be only background.

For \*s  
tra  
par  
assun  
layers  
resol  
chan  
\*c  
rec  
up  
E<sub>do</sub>



# Background Rejection (gory details)

Muons from LHC: Have to have energy  $\gtrsim 50$  GeV to reach detector,  
incident with rate  $\sim 10$  Hz  $\rightarrow \sim 10^9$  over HL-LHC run

They do travel upwards, but they do not reconstruct a displaced vertex.

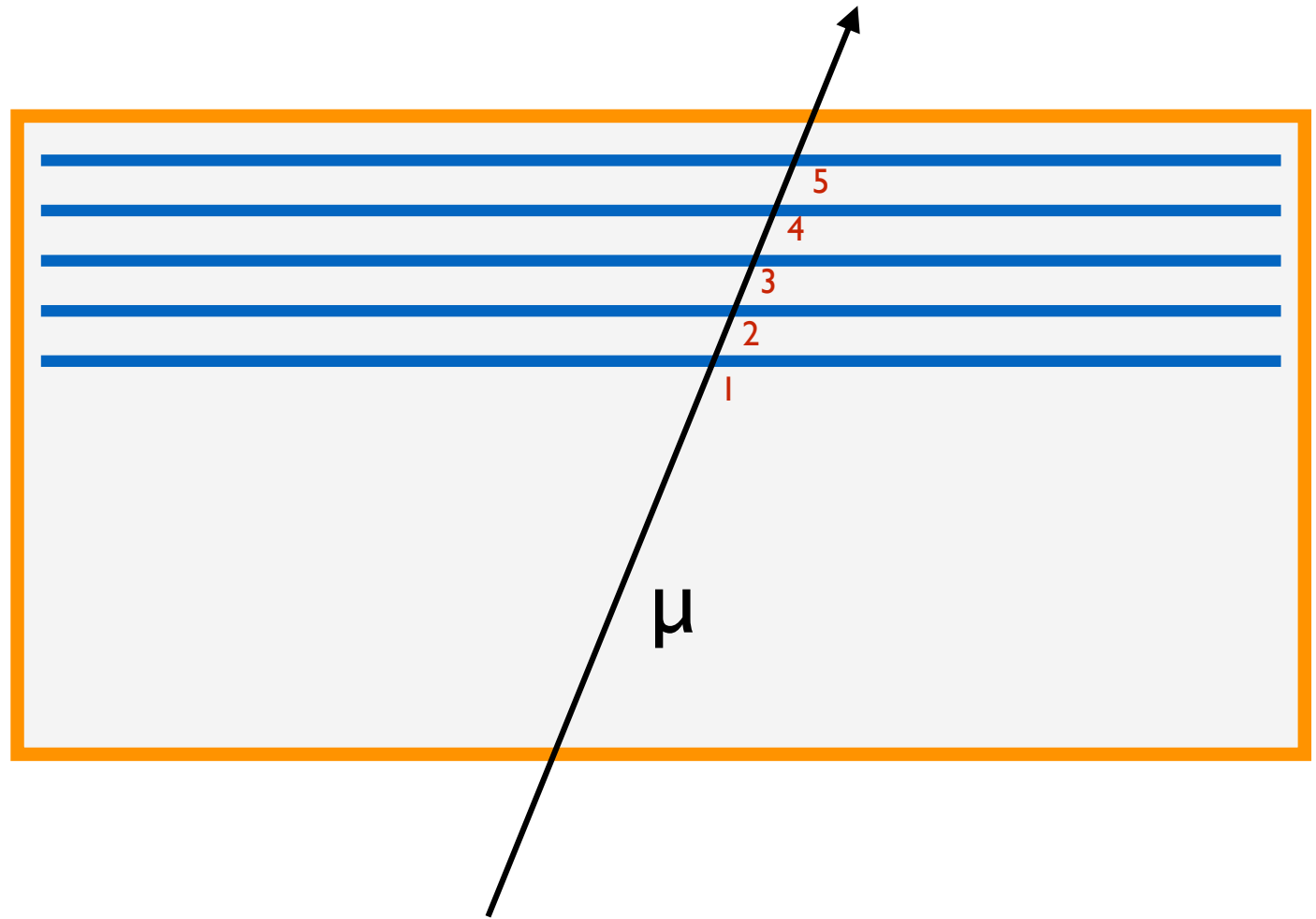

# Background Rejection (gory details)

Muons from LHC: Have to have energy  $\gtrsim 50$  GeV to reach detector,  
incident with rate  $\sim 10$  Hz  $\rightarrow \sim 10^9$  over HL-LHC run

Ignoring orders-of-magnitude suppression  
from boost (!!)  
 $\ll 10^7$  decay in volume,  
but again,  
\*no DV\*  
(and detectable by  
intersection of final and  
initial state trajectory)

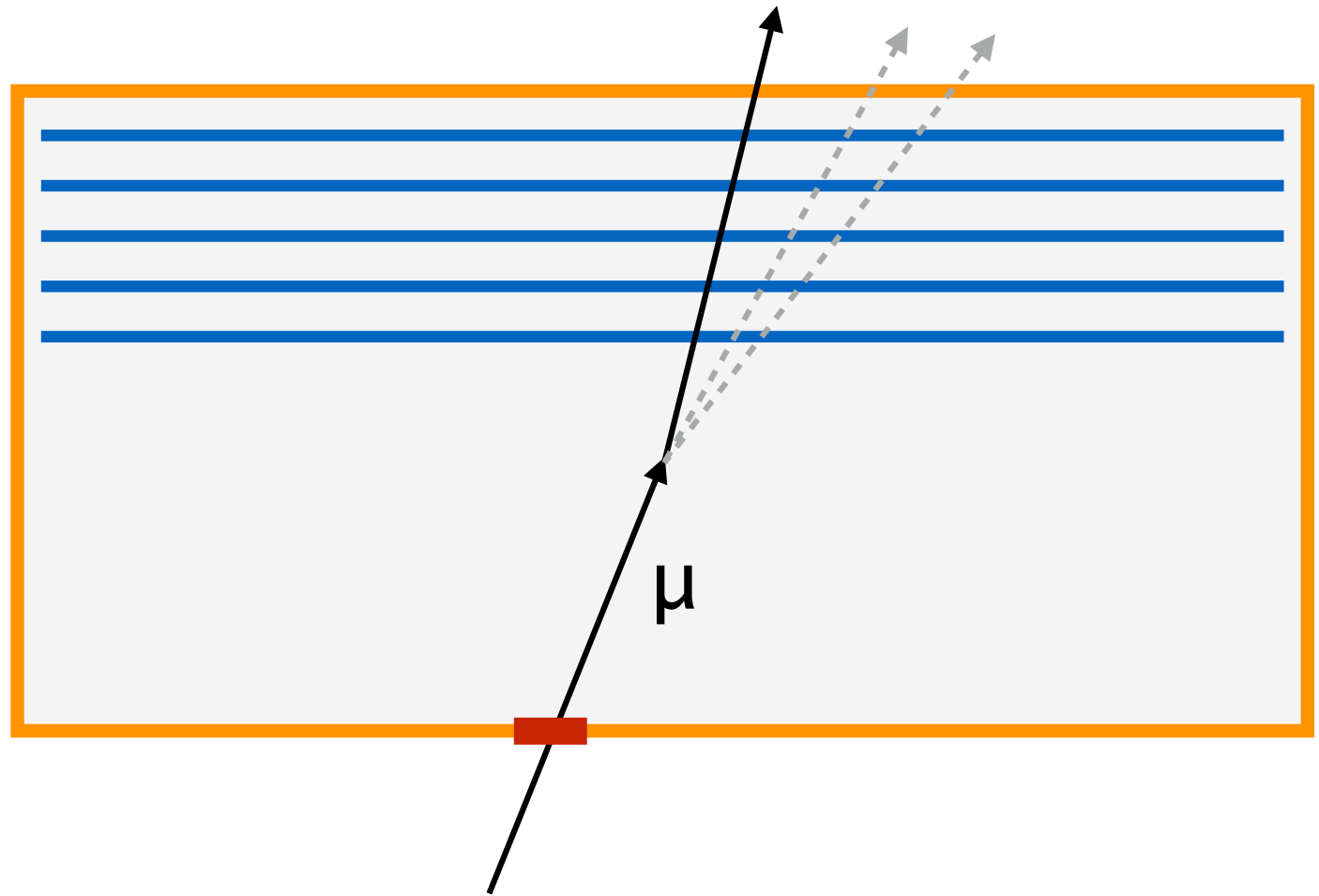

# Background Rejection (gory details)

Muons from LHC: Have to have energy  $\gtrsim 50$  GeV to reach detector,  
incident with rate  $\sim 10$  Hz  $\rightarrow \sim 10^9$  over HL-LHC run

$\sim 1000$  undergo rare  
decay into  $eee\nu\nu$   
( $\text{Br} \sim 3 \times 10^{-5}$ )  
 $\rightarrow$  genuine DV!

Two possible rejection  
strategies:

- 1) reject *narrow* decay  
cones (where all particles  
are caught by tracker)  
with *odd* numbers of  
tracks, indicating charged  
parent particle
- 2) reject with **scintillator**  
and **main detector** vetoes  
(assuming efficiencies 99%  
and 90% respectively)

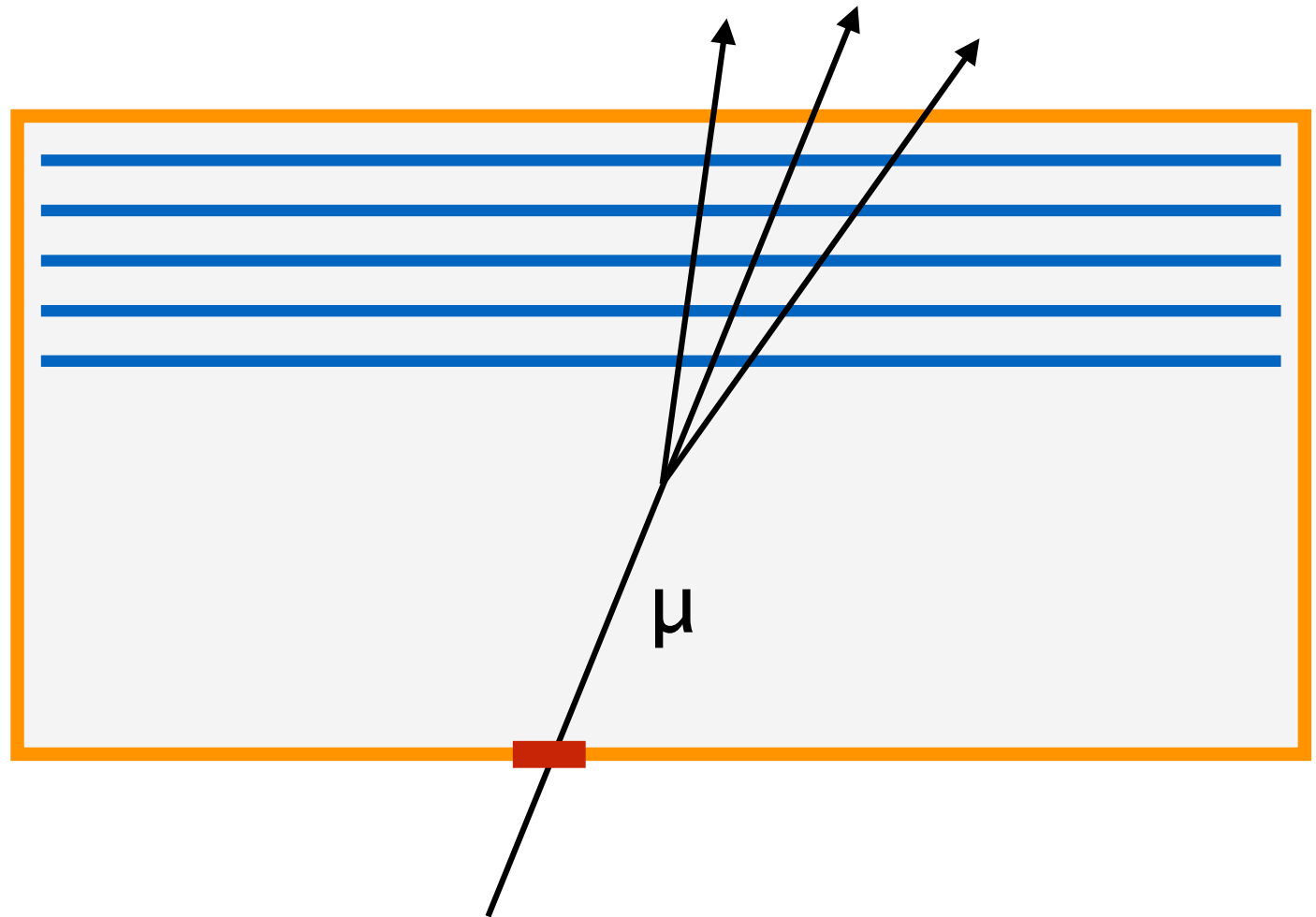

# Background Rejection (gory details)

Muons from LHC: Have to have energy  $\gtrsim 50$  GeV to reach detector,  
incident with rate  $\sim 10\text{Hz} \rightarrow \sim 10^9$  over HL-LHC run

$\sim 10$  scatter off air  
and form genuine DV

easily veto with  
scintillator alone.

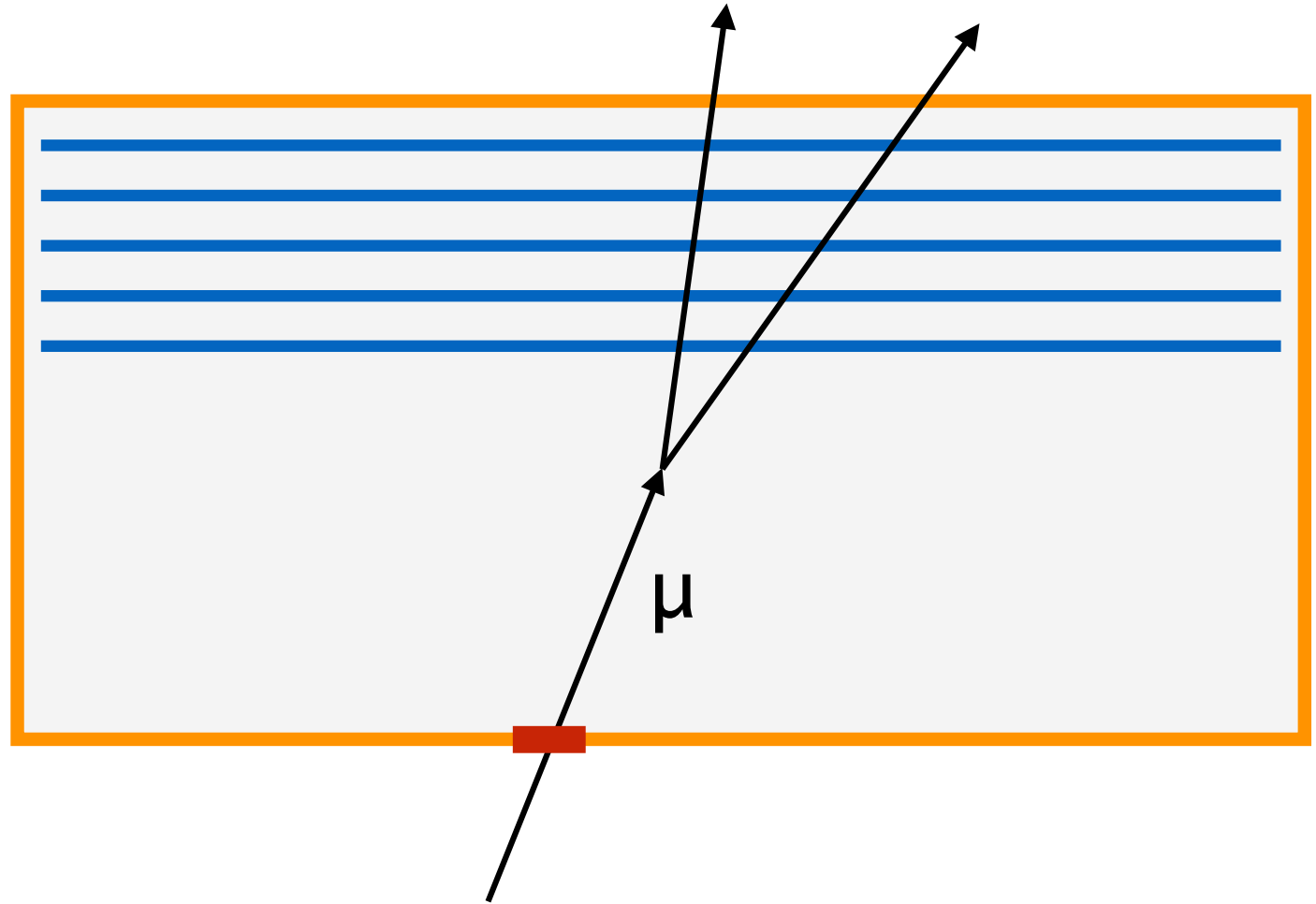



# Background Rejection (gory details)

Isotropic neutrino haze from CR interactions with atmosphere:

**Most dangerous BG,  
naively it looks exactly  
like LLP signal**

Can compute rate using  
Frejus measurements of  
atmospheric  $\nu_\mu$  flux. ( $\nu_e$   
much lower, can be dealt  
with similarly)

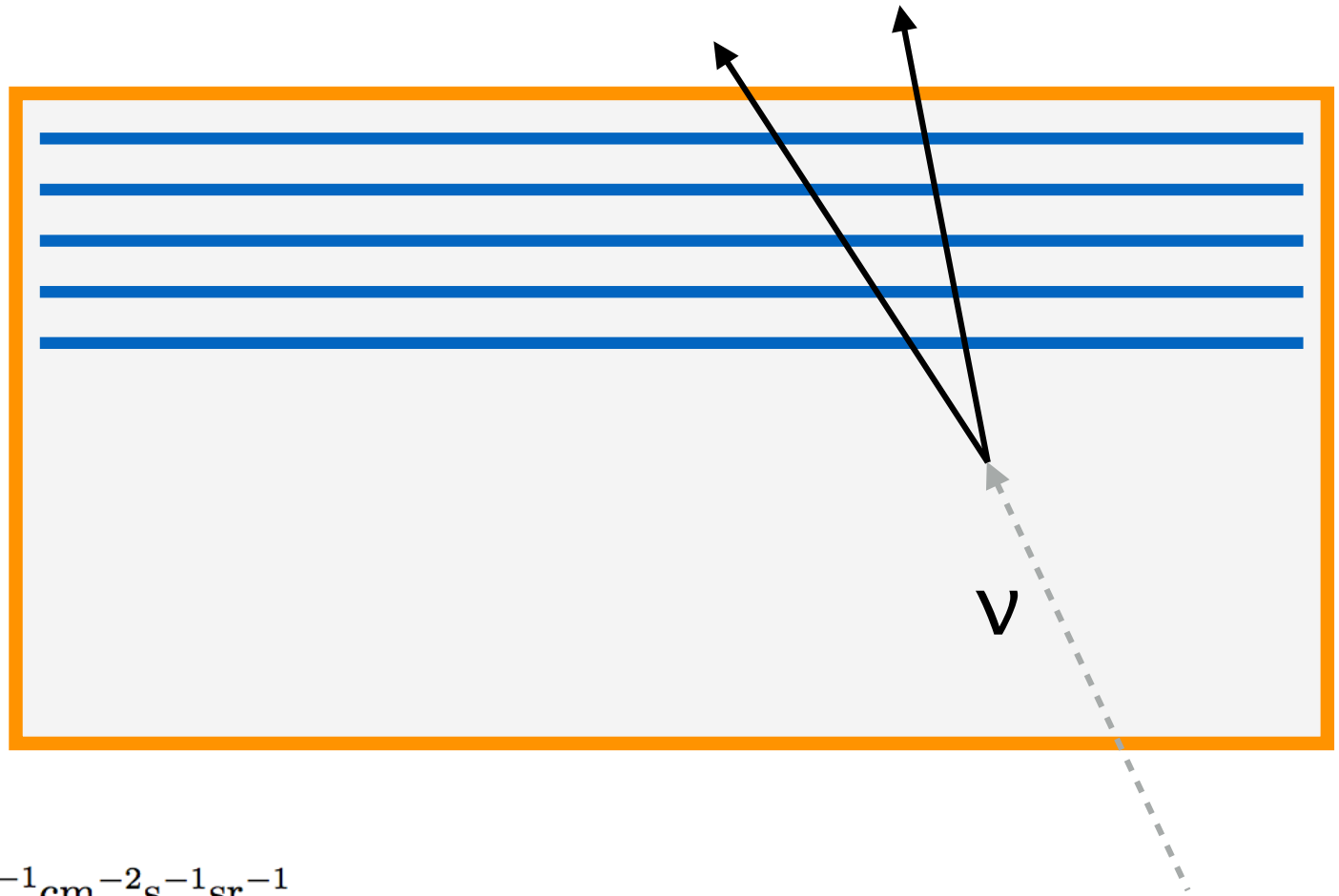

$$\frac{d\Phi}{dE_\nu} \sim 0.06 \left( \frac{\text{GeV}}{E_\nu} \right)^3 \text{ GeV}^{-1} \text{ cm}^{-2} \text{ s}^{-1} \text{ sr}^{-1}$$

# Background Rejection (gory details)

Only have to worry about neutrino scatters that give 2+ charged particles to give DV.

Exclusive scattering cross sections known at ~30% level Formaggio, Zeller, 1305.7513

Get about 60 events per year with proton in final state.

- Most of these protons are highly non-relativistic, can be tagged using MATHUSLA's ~0.05c speed resolution on charged particle tracks.
- Vetoing low-multiplicity DVs with single highly-NR track eliminates most of these BG events.
- Can also use geometric cuts: LLPs decaying to visible particles are either narrow cones pointing back to IP or broad cones. Neutrino final states (especially relatively high-energy ones with relativistic protons) are very narrow cones, mostly not pointing at IP.
- applying both NR-proton-veto ( $v < 0.6c$ ) and geometric cut, get  $< 1$  event/year (using very low cut on  $v$  and pessimistic estimates of final state kinematics)

Get about 10 events per year without protons in final state

- This small number can be vetoed using above geometry cut alone

Most naively like

Can compare Frejus neutrino atmospheric muon flux with

$$\frac{d\Phi}{dE_\nu} \sim$$

# Background Rejection (gory details)

Also get neutrinos from LHC collisions, mostly low-energy, from hadron decays

Can estimate rate using generic GEANT simulation of main detector.

Cannot use naive geometric cut used on CR neutrinos, but after NR-proton-veto, only left with  $O(1)$  events per year.

There are other handles on their decay (detailed geometry, multiplicity, speed, ...)

→ with further study should easily be able to reject.

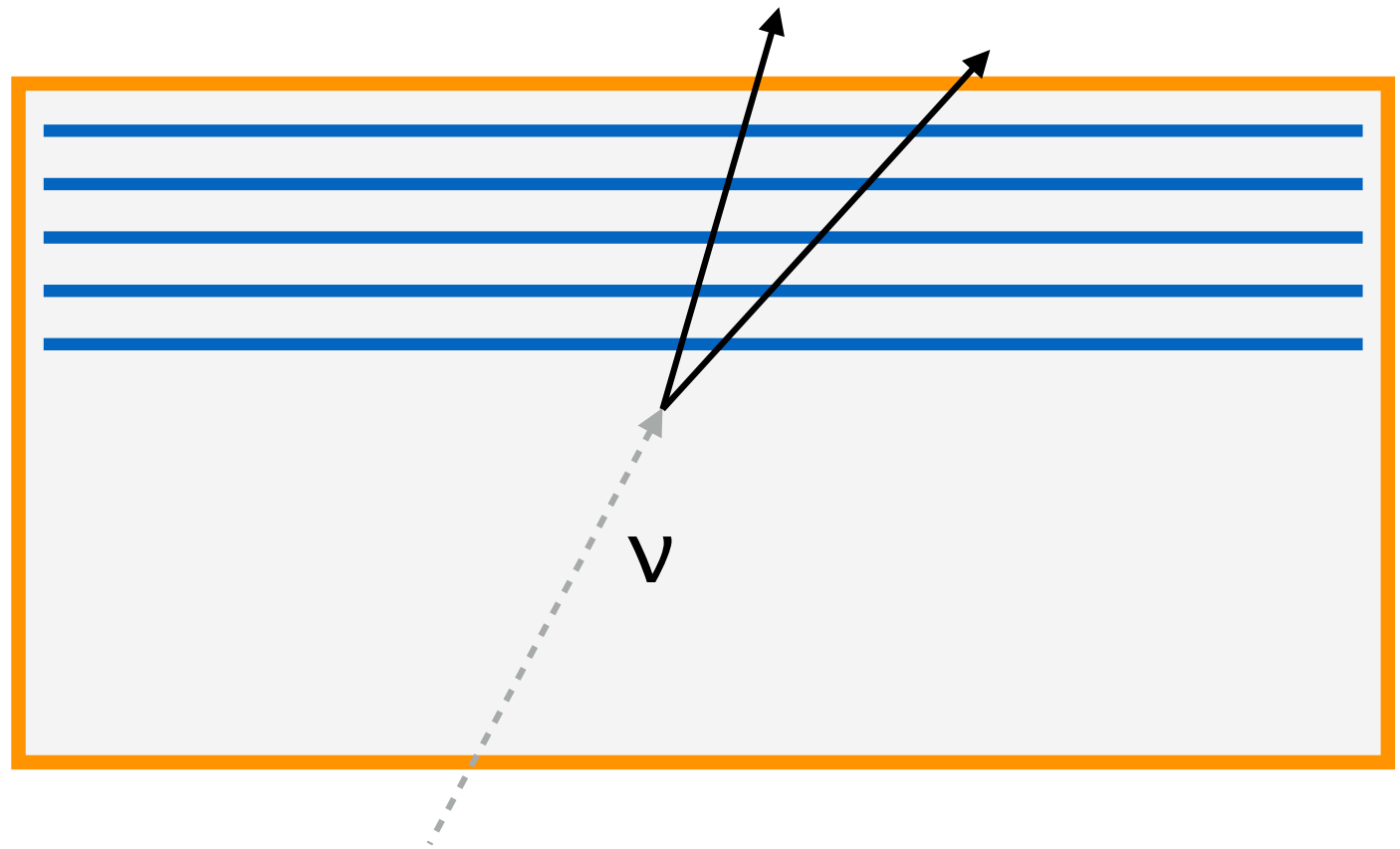

# Background Rejection (gory details)

None of these BG rejection strategies seriously affect signal efficiency.

*Rarer BG processes: production of \*isolated\* Kaons in rocks from CR scattering that migrate to detector and decay, etc... estimates of rates  $\ll$  previous BGs*

**ALL OF THIS HAS TO BE STUDIED IN MORE DETAIL WITH MORE SIMULATIONS.** Most importantly:

- CR simulations & MATHUSLA test stand data to sanity-test rejection strategies to the extent possible using MC statistics (+ some cleverness to go beyond simple statistical?)
- Full simulation of neutrino background and rejection strategies. Refine geometric veto, especially for neutrinos from LHC. Get more realistic estimate of NR-proton-veto efficiency (will be better than our estimates, due to pessimistic assumptions we made about final state kinematics, and by ignoring remnants of shattered nucleus)

Further details on  
MATHUSLA LLP sensitivity

# Low-Mass Regime

Spatial resolution  $\Delta x$  of trackers is most important bottleneck:

Corresponds to **maximum LLP boost** for which multi-pronged DV can be reconstructed, which is **crucial for BG rejection!**

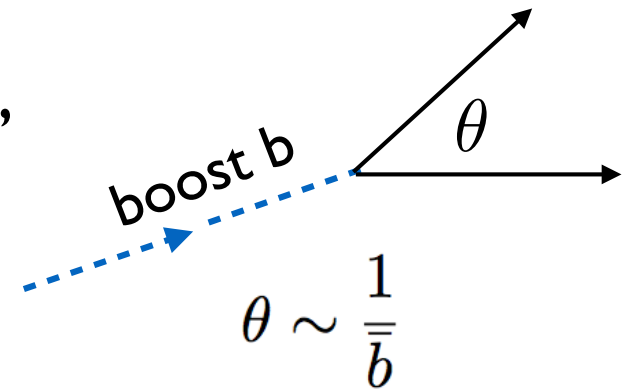

$$b_{LLP}^{max} \sim 1000 \left( \frac{1cm}{\Delta x} \right)$$

→ **Minimum LLP mass that can be probed “without BG”**

$$m_{LLP}^{min} \sim \frac{m_{parent}}{2b_{LLP}^{max}} \sim \left( \frac{m_{parent}}{2000} \right) \left( \frac{\Delta x}{1cm} \right)$$

~ 10 MeV for LLPs from B decays

~ 0.1-1 GeV for weak-TeV scale production

Interesting complementarity with SHiP?

# LLP Diagnosis

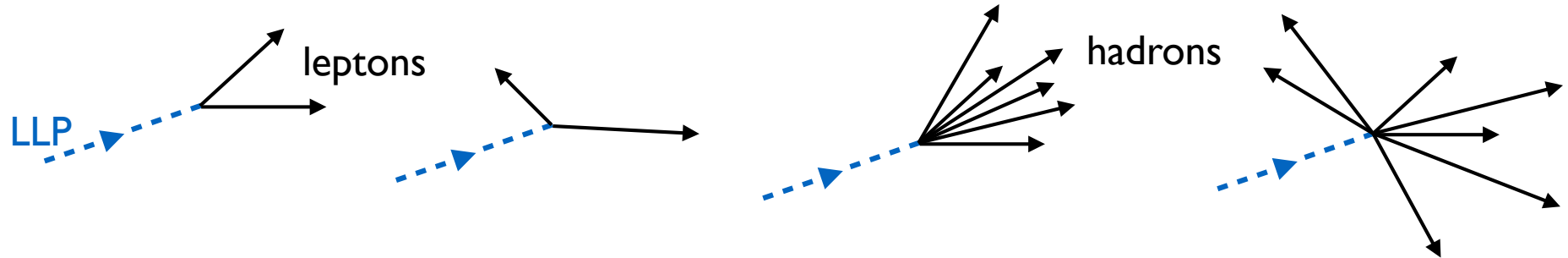

Geometry of LLP final state trajectories reveals LLP **boost** event-by-event

Final state multiplicity can diagnose **decay mode**.

Optional: layer of material between tracking layers for  $e/\mu$  discrimination and  $\gamma$  detection

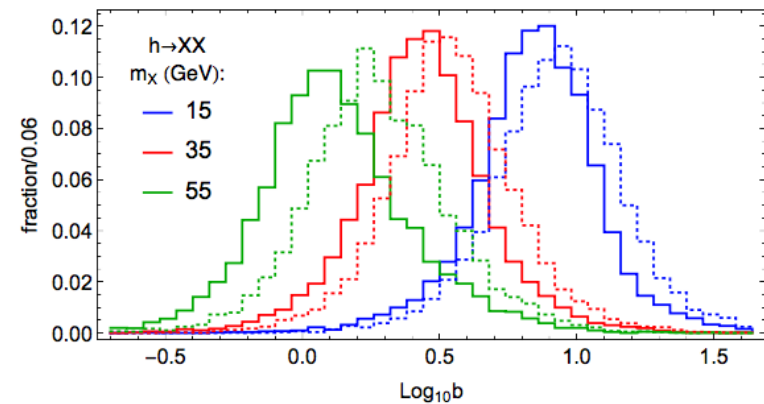

Correlate with main detector to diagnose **production mode!**

For known production mode, **boost**  $\sim$  **LLP mass!**

LLPs @ LHC



# Strategy



The spectacular nature of LLP (decay or visible propagation) means precise kinematics are less important than

**character** (jets, leptons, ...) and **approx energy range** (10 GeV, 100 GeV)

of

**prompt objects produced with LLP and LLP decay products**

Do this with an eye for what we can trigger on, and cut on to reduce BG:

**MET** (100s GeV), **hard jets** (100s GeV), **hard enough EM objects** (10s GeV)

**DV in ATLAS Muon System**

**displaced jets in CMS tracker**, as long as they pass LI threshold

# Simplified Models

Consider production and decay mode separately.

Geometrical nature of LLP decay signal means you imagine ‘pasting’ different LLP decays onto the same LLP event for different lifetimes.

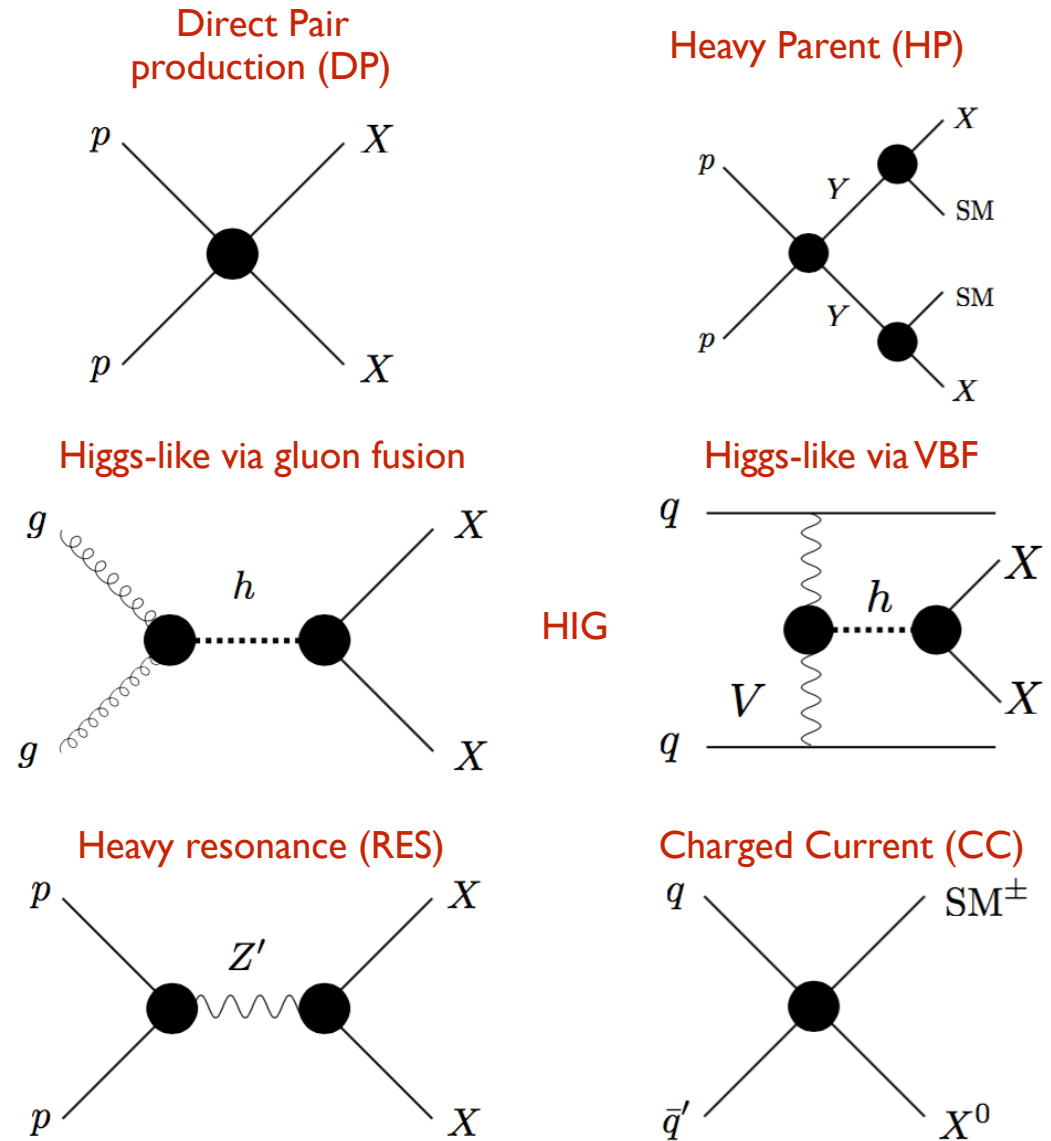

Figure 2.1: Schematic illustrations of LLP production modes in our simplified model framework. From top to bottom and left to right: direct pair production (DPP); heavy parent (HP); Higgs modes (HIG), including gluon fusion and VBF production (not shown here is  $VH$  production); heavy resonance (RES); charged current (CC).

# Simplified Models

## Neutral LLPs

Production \ Decay	$\gamma\gamma(+\text{inv.})$	$\gamma + \text{inv.}$	$jj(+\text{inv.})$	$jj\ell$	$\ell^+\ell^- (+\text{inv.})$	$\ell_\alpha^+ \ell_{\beta \neq \alpha}^- (+\text{inv.})$
DPP: sneutrino pair	†	SUSY	SUSY	SUSY	SUSY	SUSY
HP: squark pair, $\tilde{q} \rightarrow jX$ or gluino pair $\tilde{g} \rightarrow jjX$	†	SUSY	SUSY	SUSY	SUSY	SUSY
HP: slepton pair, $\tilde{\ell} \rightarrow \ell X$ or chargino pair, $\tilde{\chi} \rightarrow WX$	†	SUSY	SUSY	SUSY	SUSY	SUSY
HIG: $h \rightarrow XX$ or $\rightarrow XX + \text{inv.}$	Higgs, DM*	†	Higgs, DM*	RH $\nu$	Higgs, DM* RH $\nu^*$	RH $\nu^*$
HIG: $h \rightarrow X + \text{inv.}$	DM*, RH $\nu$	†	DM*	RH $\nu$	DM*	†
RES: $Z(Z') \rightarrow XX$ or $\rightarrow XX + \text{inv.}$	$Z'$ , DM*	†	$Z'$ , DM*	RH $\nu$	$Z'$ , DM*	†
RES: $Z(Z') \rightarrow X + \text{inv.}$	DM	†	DM	RH $\nu$	DM	†
CC: $W(W') \rightarrow \ell X$	†	†	RH $\nu^*$	RH $\nu$	RH $\nu^*$	RH $\nu^*$

Filled entries are realized in simplest benchmark theories:  
SUSY-like, Higgs portal, gauge portal  $Z'$ , RH neutrinos, DM

**NB: some thoughts on  
relationship between various  
LLP detector proposals**

All need to be investigated more.

We really should just build them all,  
they're (mostly) pretty cheap...

Some of these comparisons will be done “officially” as part of  
PBC BSM report\*, keep eye out end of 2018!

(\*for low-scale models that SHiP can access)

# CODEX-b

Gligorov, Knapen, Papucci,  
Robinson, 1708.09395

Dedicated DV detector underground, in existing cavity near LHCb

+ Definitely more affordable than something on MATHUSLA scale

+ Probably easier to instrument for  $< 10\text{-}100$  MeV mass regime, and maybe even calorimetry/particle ID for detailed LLP investigations

-  $1/200$  MATHUSLA sensitivity,  $1/50$  if we burn out VELO with  $1/ab$   
→ scale down  $R_s$  by same factor

*Important detailed question for future: how does cost/capabilities compare to similar-reach surface detector?*

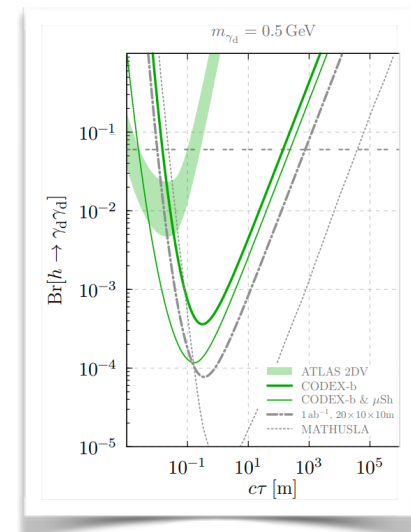
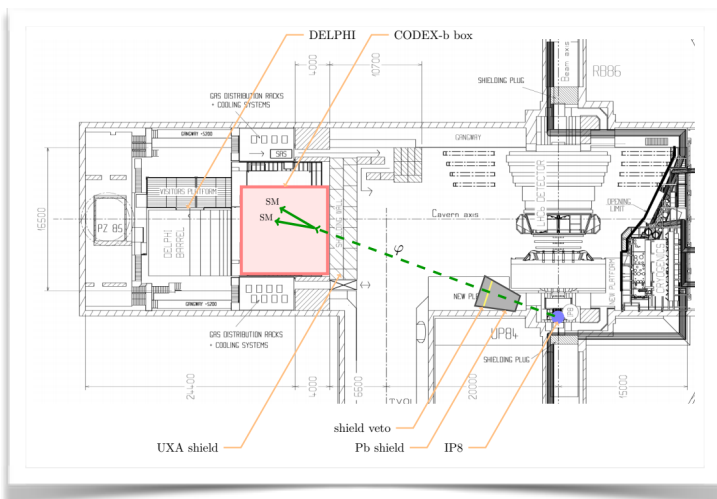

# FASER, MATHUSLA and SHiP (*light LLPs*)

**SHiP:** For shorter lifetimes and mass  $< \sim 10$  MeV, SHiP is much better.  
**MATHUSLA** access higher scale physics and sees 10-100 more LLPs from exotic meson decays if lifetime  $\gg 100$ m.

**FASER:** “small” cylindrical ( $R = 0.2$ m,  $L = 10$ m) detector (far):

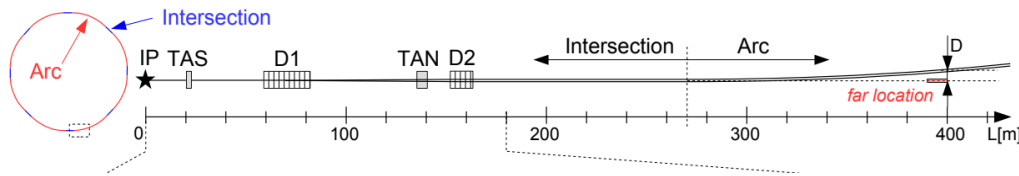

For SM+S model reach,  
**FASER + MATHUSLA > SHiP !**

*Very intriguing! Does this interplay  
apply to other low-mass LLP  
scenarios?!*

*Will be explored in PBC report.*

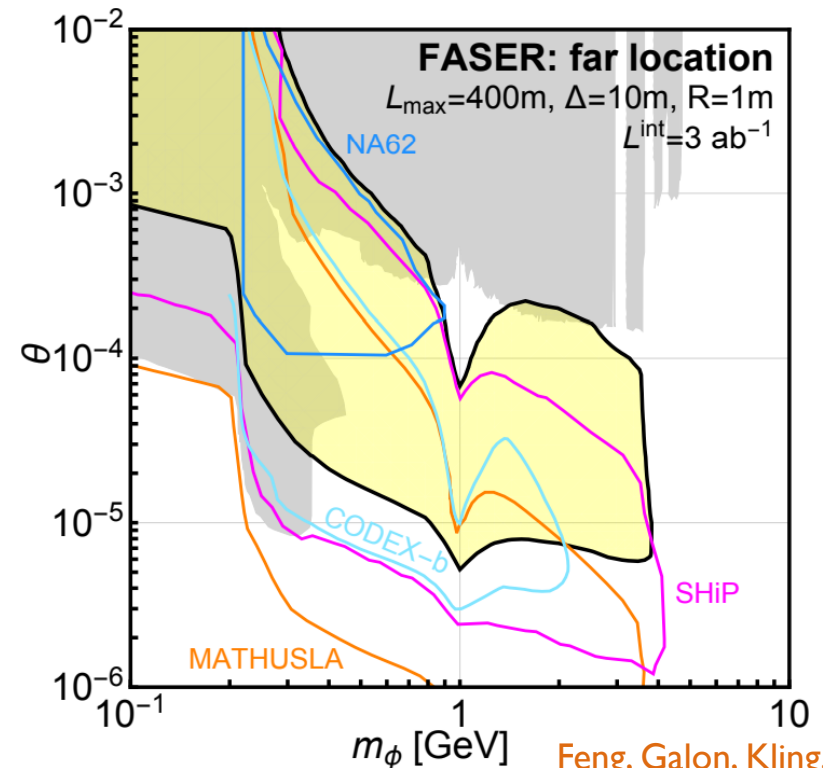

# Main Detector Timing Upgrades??

Jia Liu, Zhen Liu, Lian-Tao Wang | 805.05957

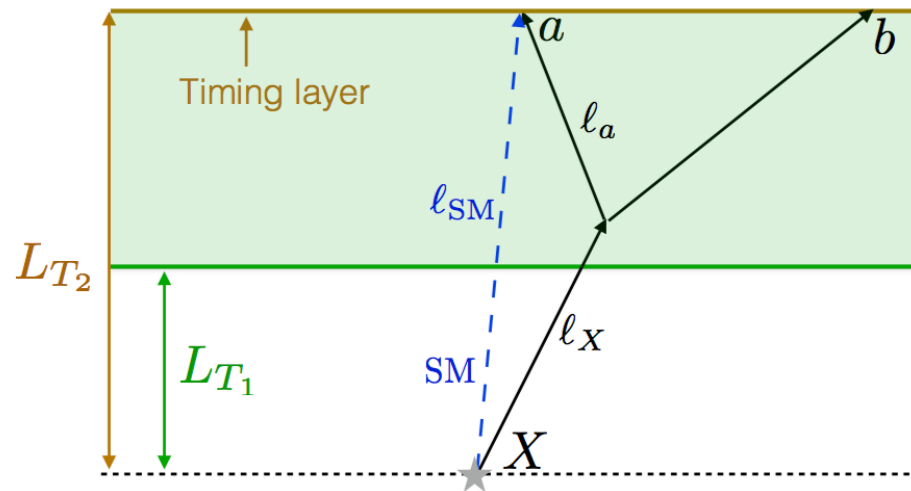

Opening angle of  
LLP decay products  
 $\sim (\text{boost})^{-1}$

Time delay of LLP decay products compared to prompt SM particles from PV:

$$\Delta t \sim \frac{\ell_{SM}}{c^2} \left( \frac{1}{3b^2} + \mathcal{O}(b^{-4}) \right)$$

$b = \text{boost}$

$$\sim 1 \text{ ns} \left( \frac{\ell_{SM}}{1m} \right) \frac{1}{b^2}$$

Quite sizable even for reasonably high  $\mathcal{O}(1)$  boosts, if you have e.g. 30ps timing!



# Main Detector Timing Upgrades??

Jia Liu, Zhen Liu,  
Lian-Tao Wang 1805.05957

Consider  $h \rightarrow XX$  (single LLP search).

Want to catch  $h+j$  production events with single 30 GeV ISR jet.

## 30ps timing layer on inside of CMS ECAL:

- + similar to proposed upgrades
- how to trigger at L1? Would need PV4d and DV4d (full timing vertices) at Level 1
- $\Delta t > 0.8\text{ns}$  timing cut ( $26\sigma$ ) to reduce hard jet fake DV background by  $10^{-10}$  to  $N < 1$

## 30ps timing layer on outside of ATLAS Muon Spectrometer

- + L1 trigger OK using Muon ROI like existing DV search
- would be amazing, but \$\$\$ for such a big 30ps timing layer? (10m radius)
- $\Delta t > 0.2\text{ns}$  timing cut ( $7\sigma$ ) to reduce hard jet fake DV background by  $10^{-6}$  to  $N < 1$

# Main Detector Timing Upgrades??

Jia Liu, Zhen Liu,  
Lian-Tao Wang 1805.05957

If BG-free, each of these two searches has  $O(1/10)$  MATHUSLA sensitivity for long-lifetimes.

That quantitative reach is not realistic, given the backgrounds not considered in the analysis and assumptions made about triggering.

However, regardless of such details, timing will *\*definitely\** improve main detector sensitivity significantly.

Furthermore, main detector LLP searches always have intrinsic advantages (full event reconstruction etc) so you want to improve those as much as you can.

**Clearly, timing is incredibly exciting for LLP searches!**