

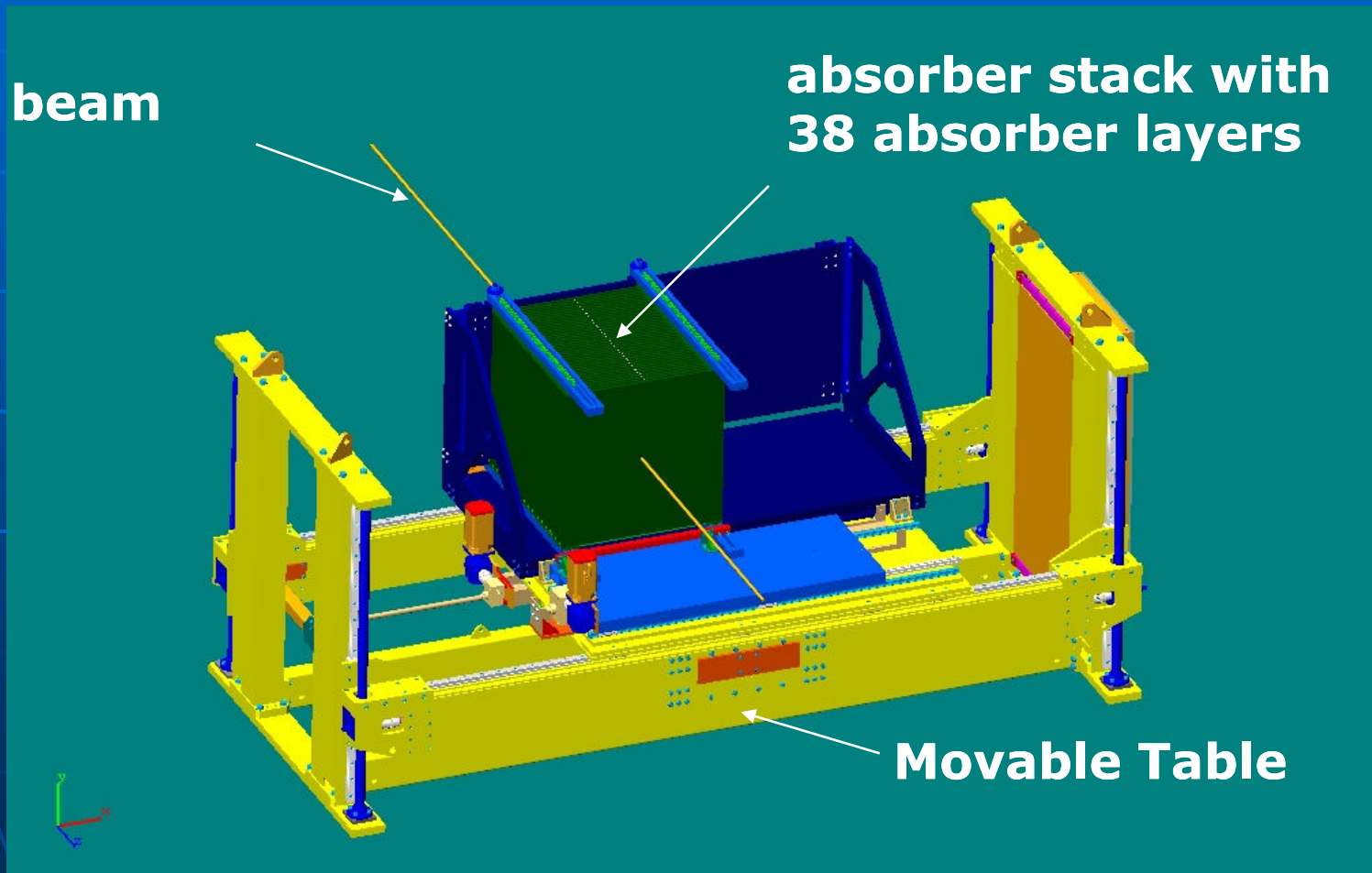

First ideas of  
tungsten plates  
implemented into the  
CALICE test beam setup

Workshop on a W HCAL Prototype  
@LAPP 24.09.2009

# Movable Table with 0° absorber stack



# 0° absorber stack with AHCAL sensitive layers

**38 sensitive layers**

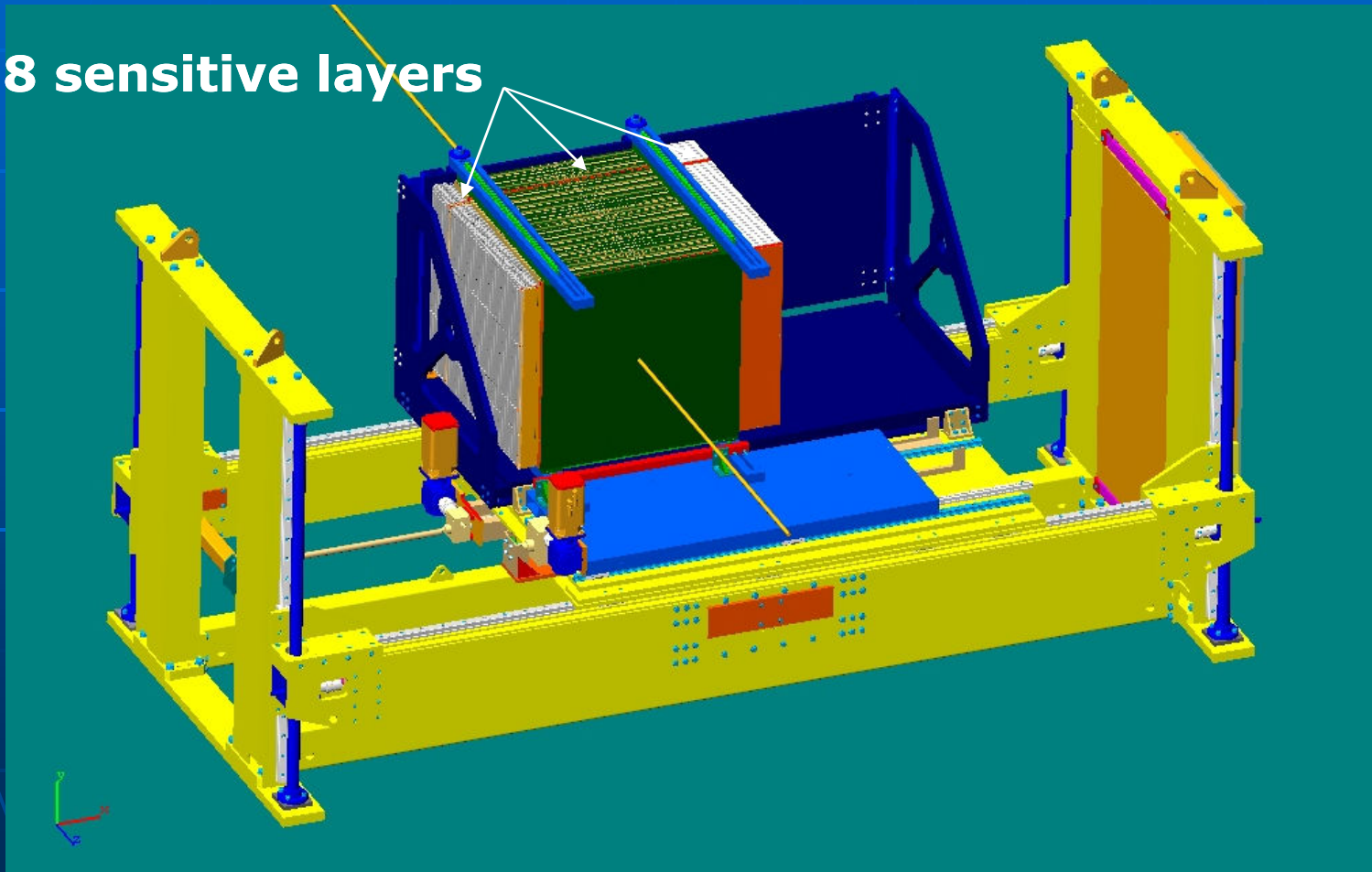

# AHCAL test beam setup

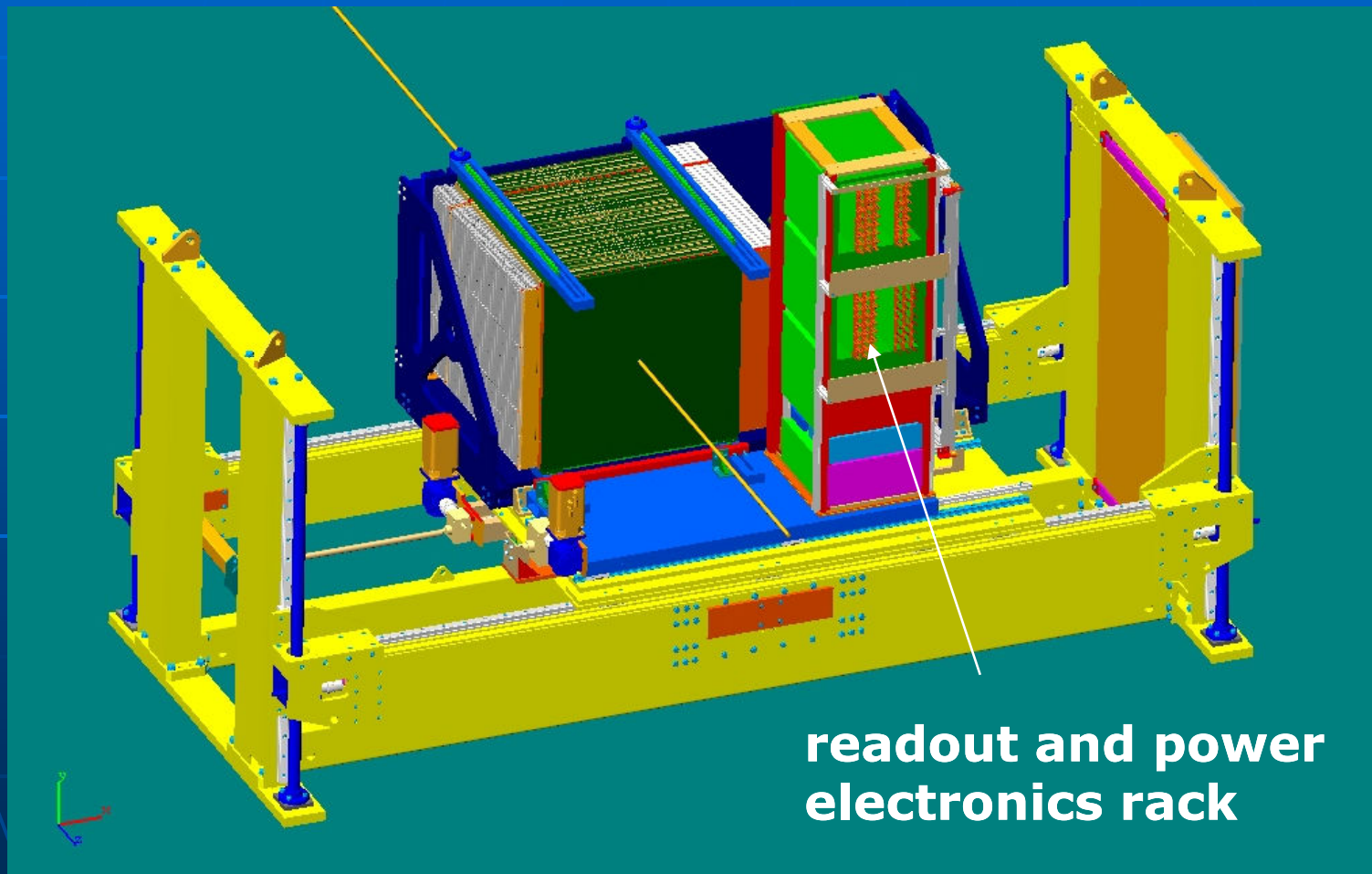

# 30° turned absorber stack

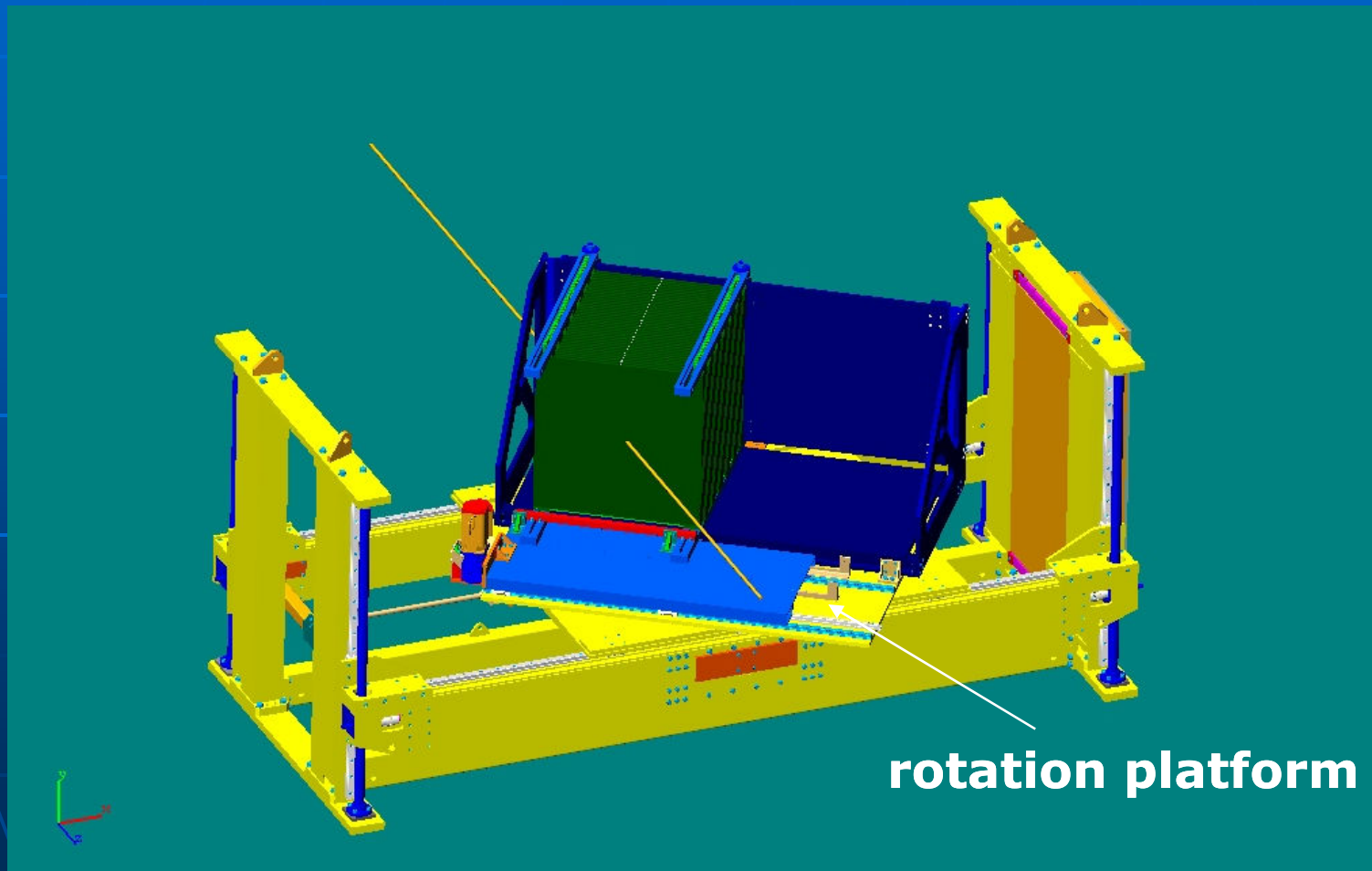

# 30° turned and shifted absorber stack

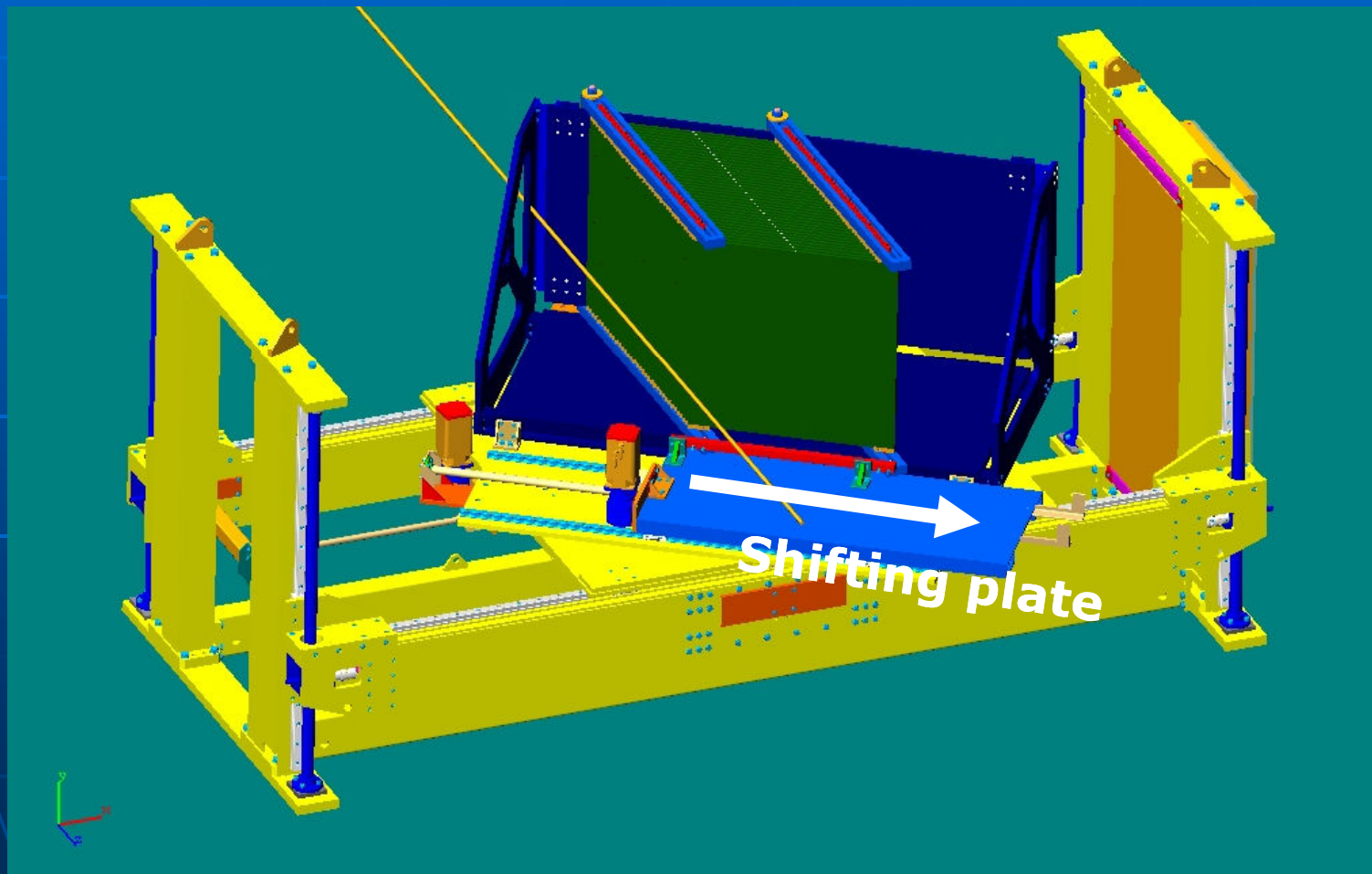

# 30° setup without sensitive layers

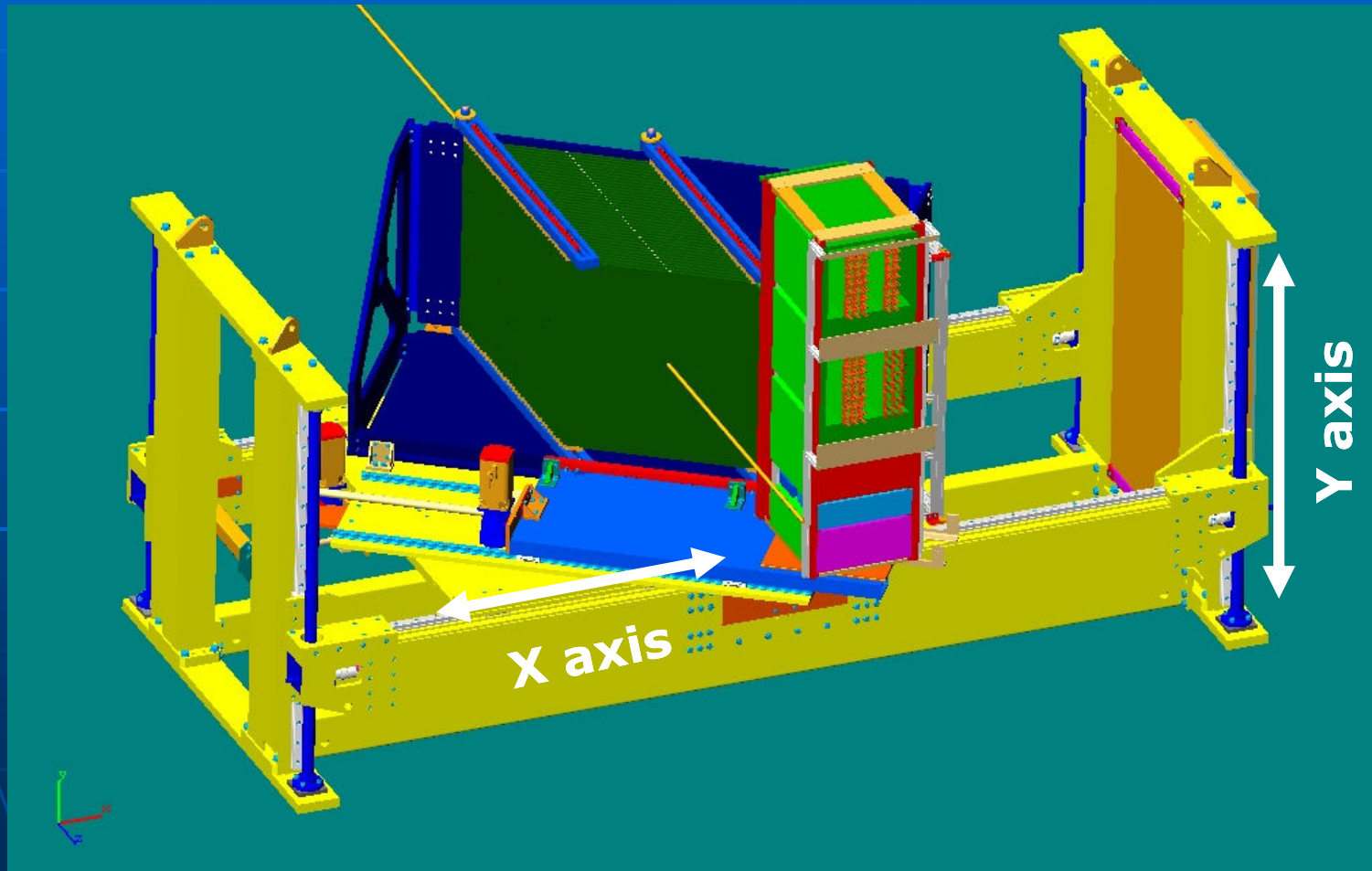

# Absorber stack plate structure

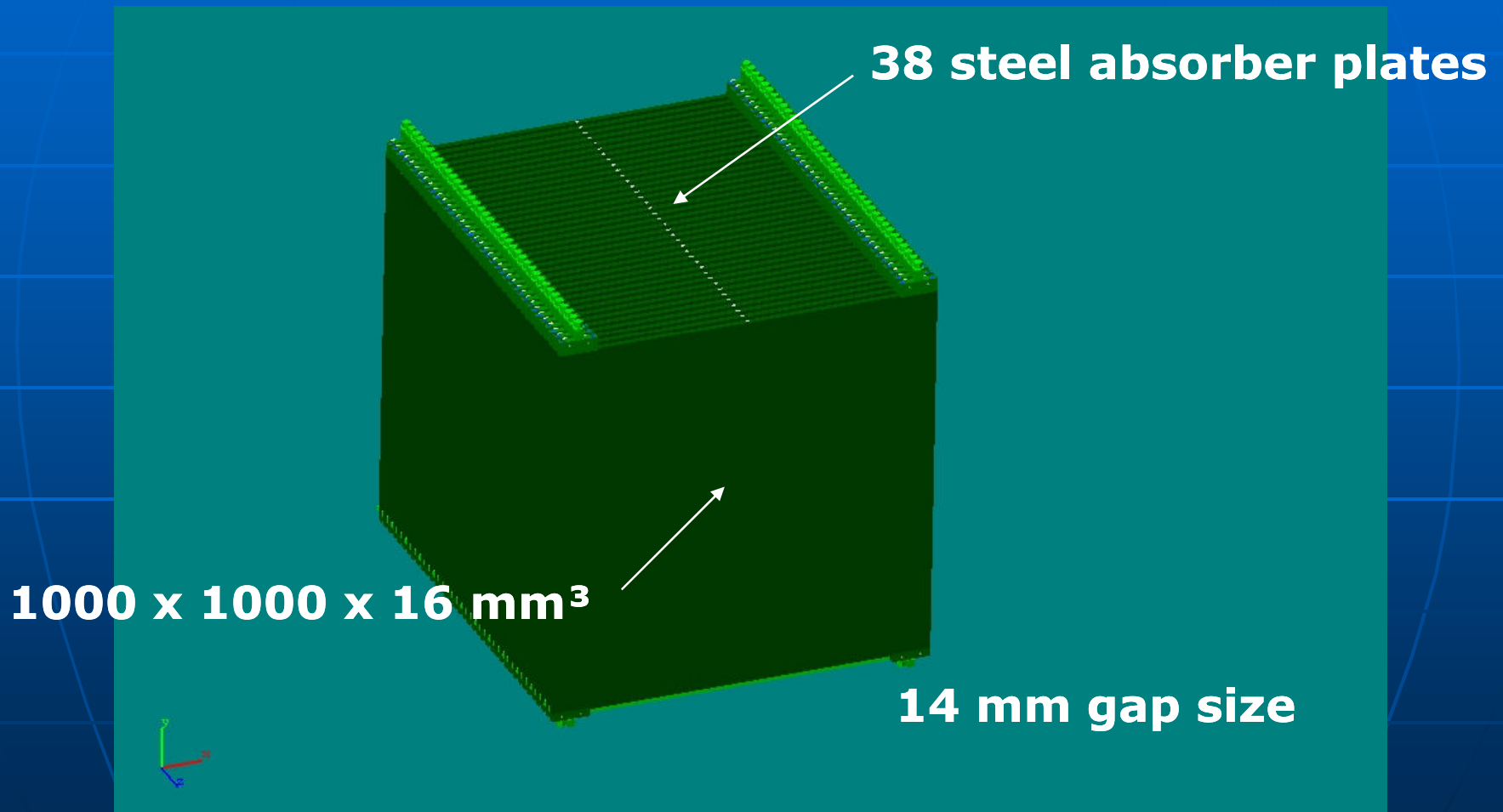



# Absorber layer system

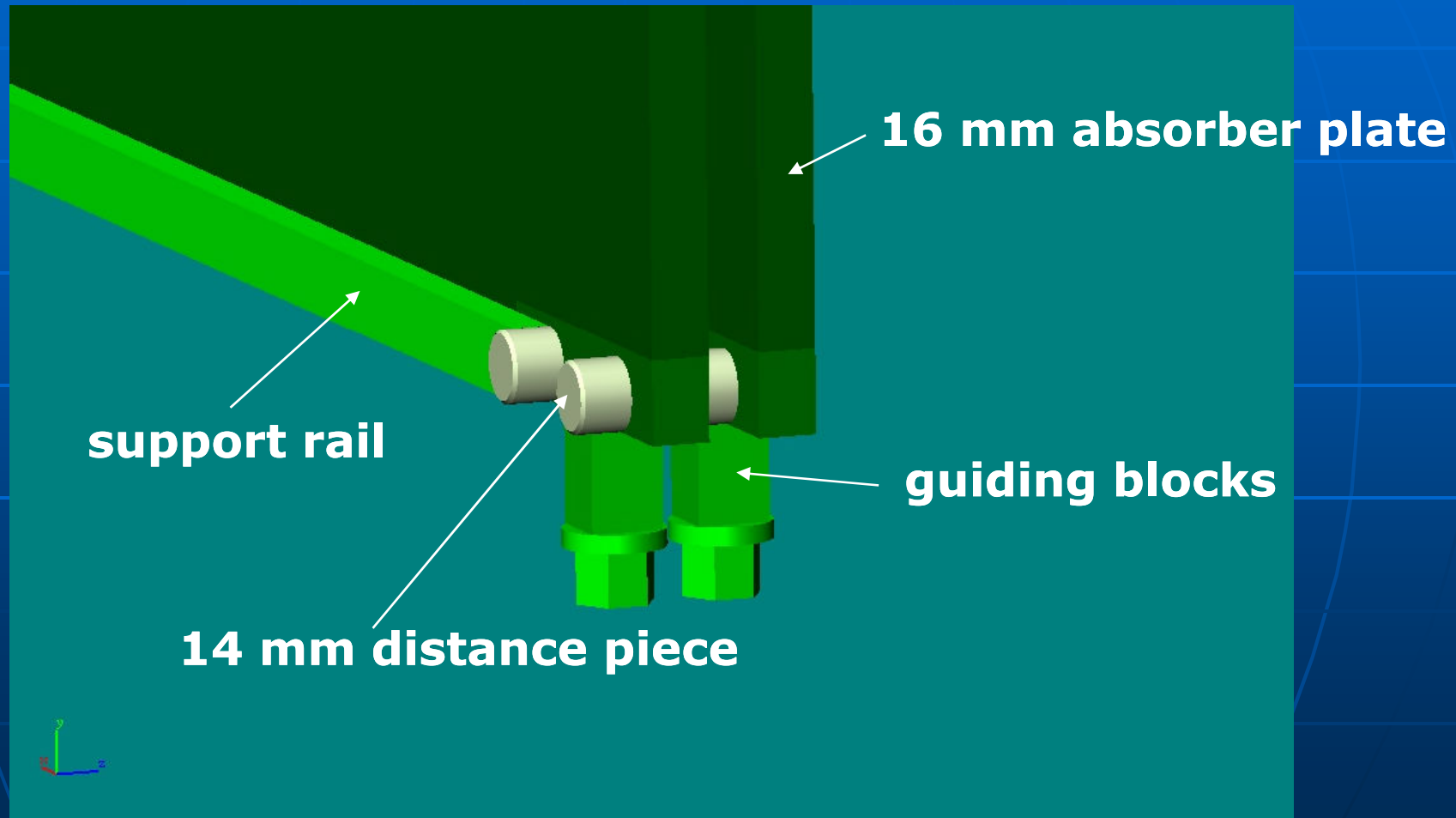

# Tungsten absorber support frame

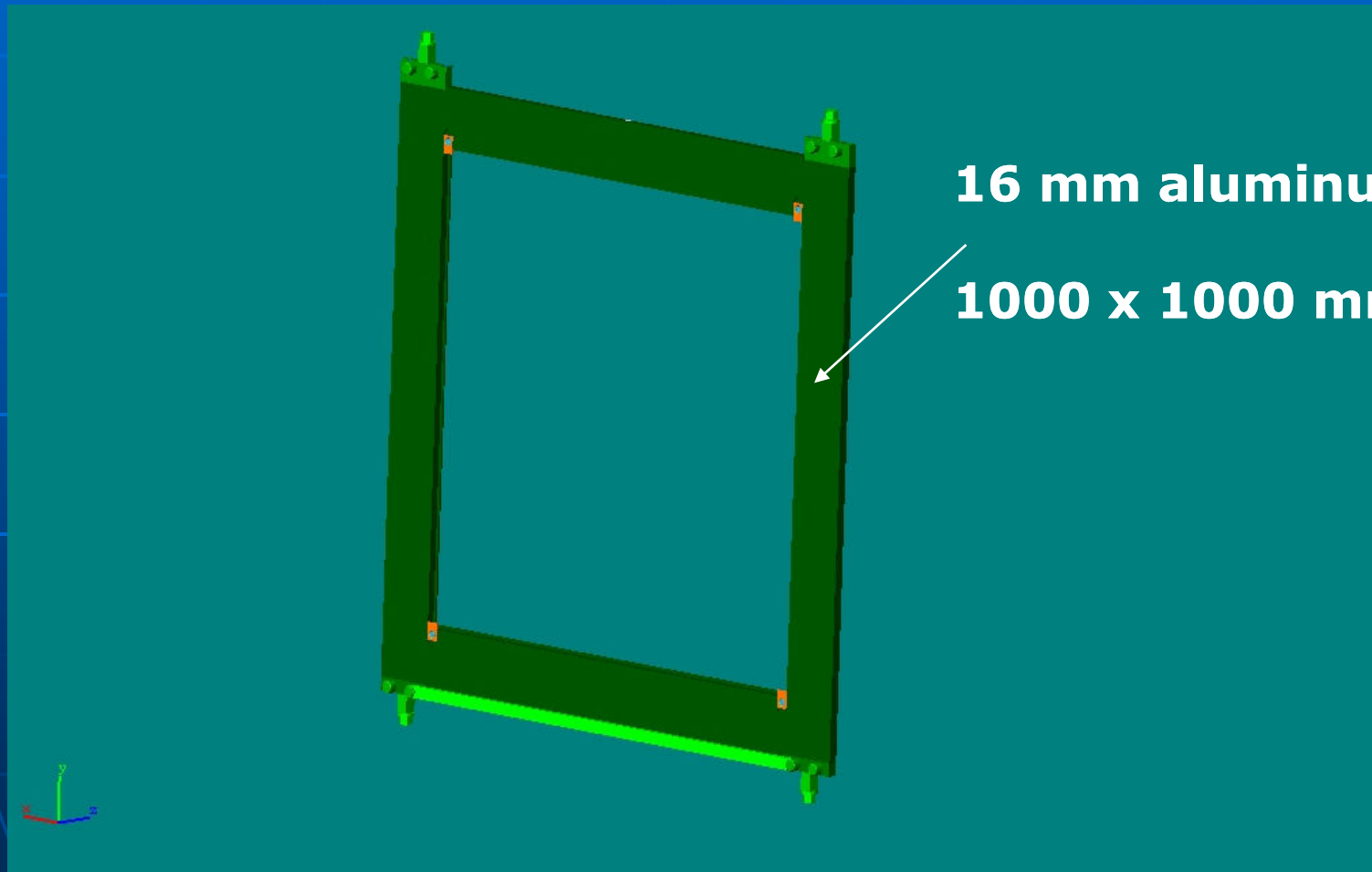

# Tungsten absorber layer

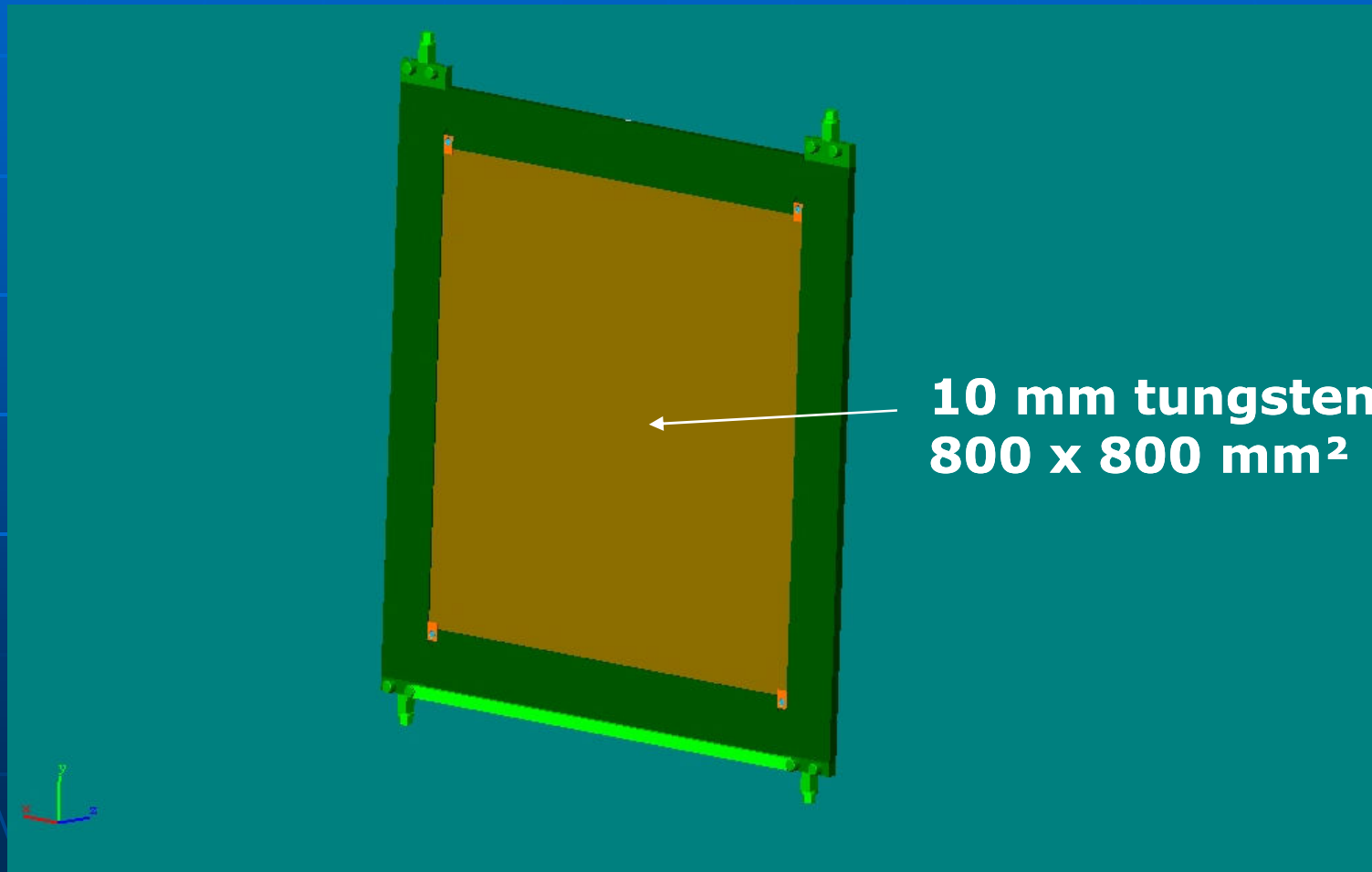

# Tungsten absorber layers with AHCAL sensitive layers

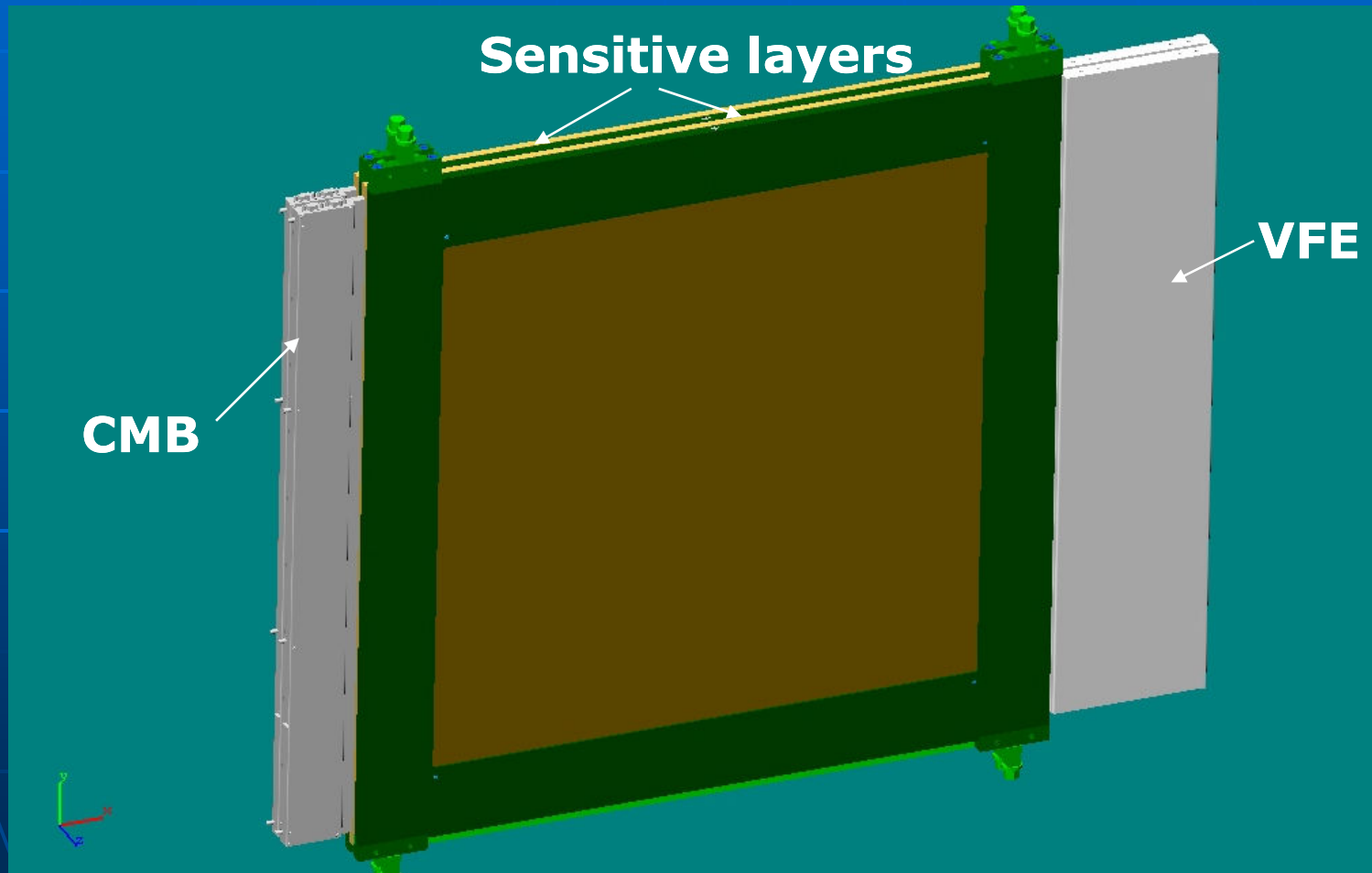

# AHCAL front end electronic

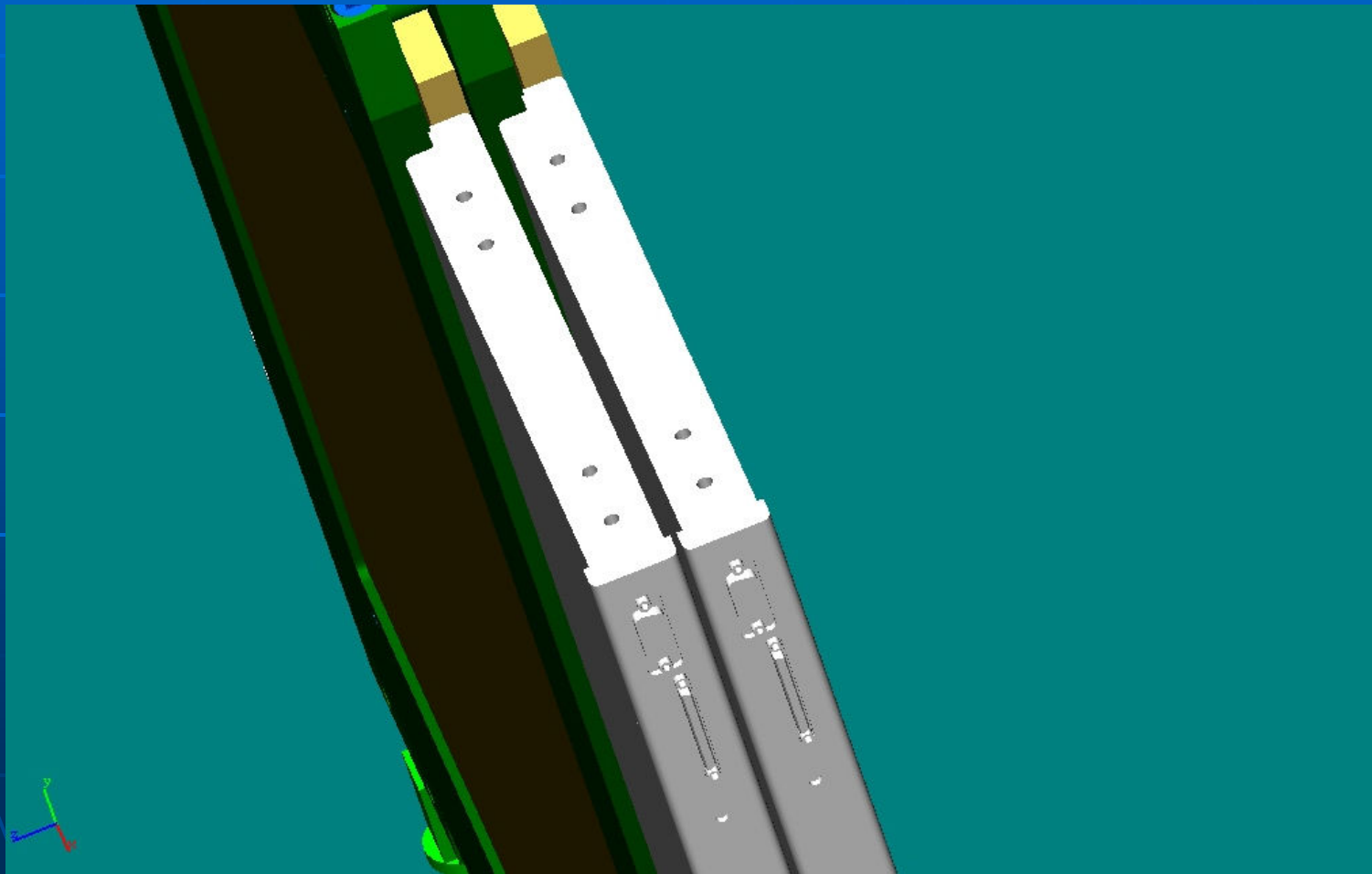

# Layer structure with steel absorber plates

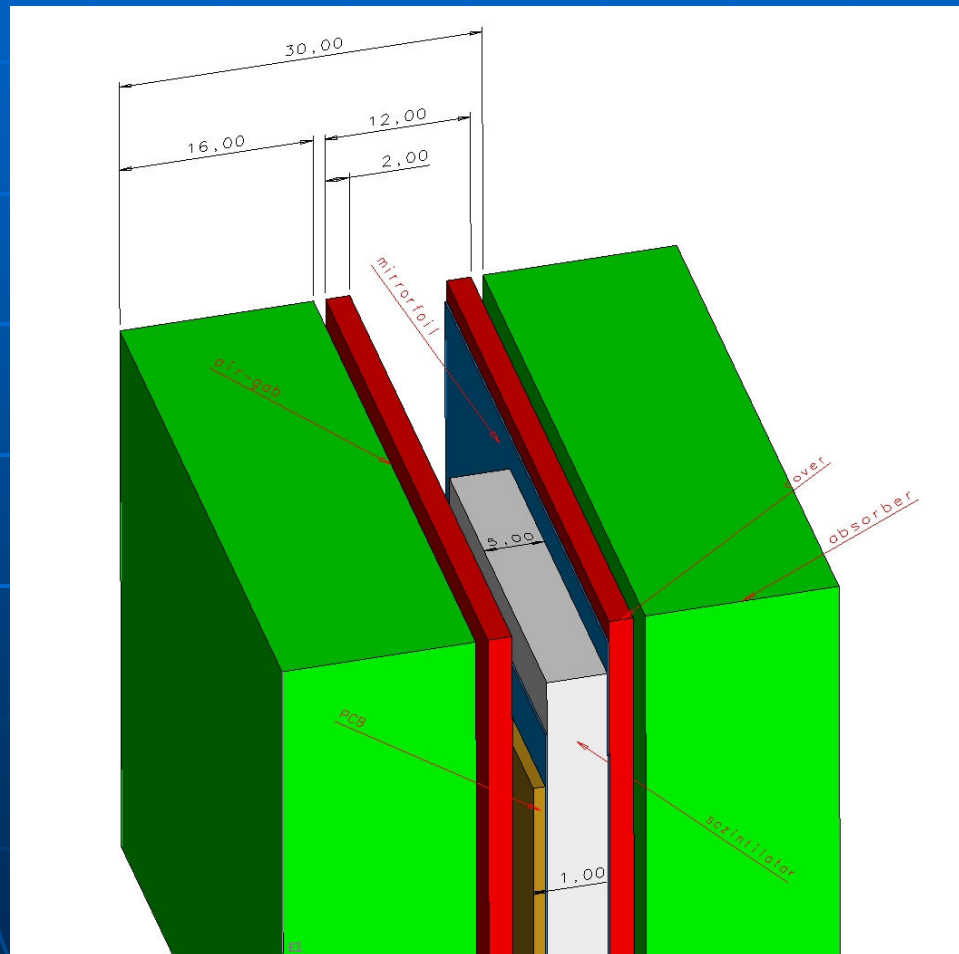

# Layer structure with tungsten absorber plates

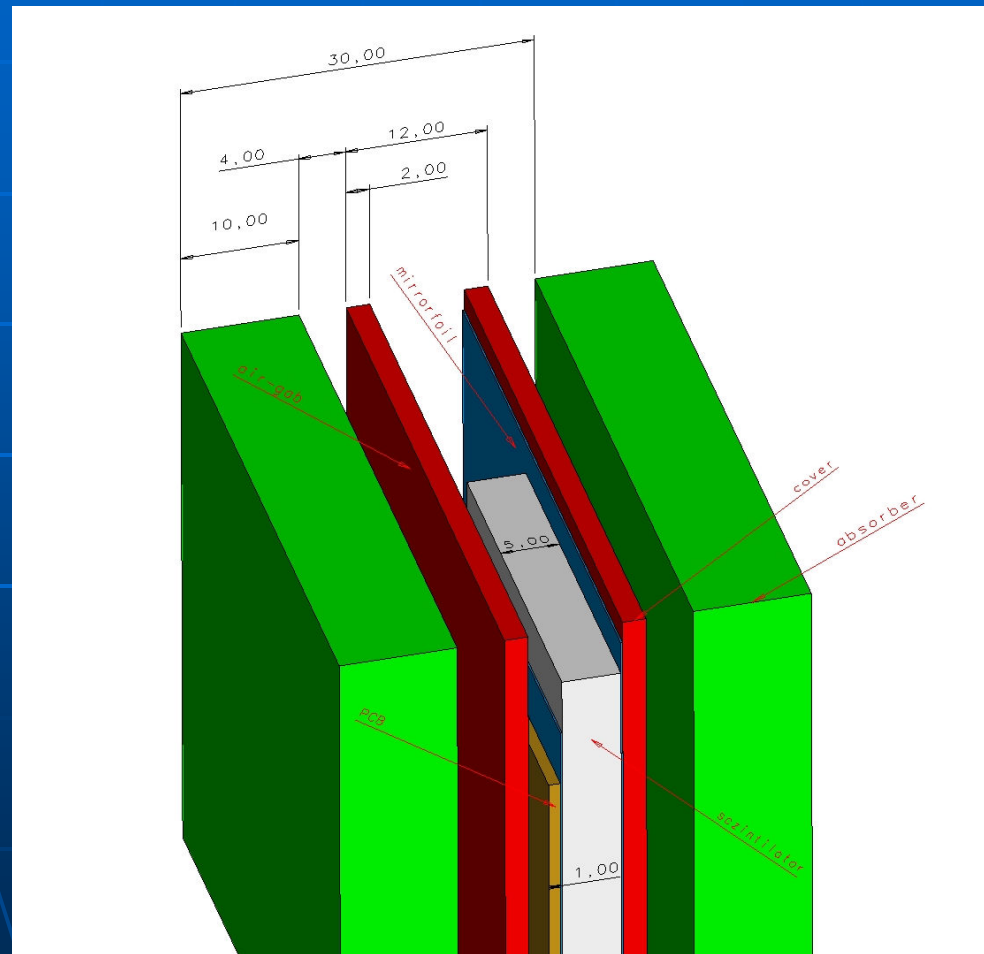

# Upgrade with new detector layers

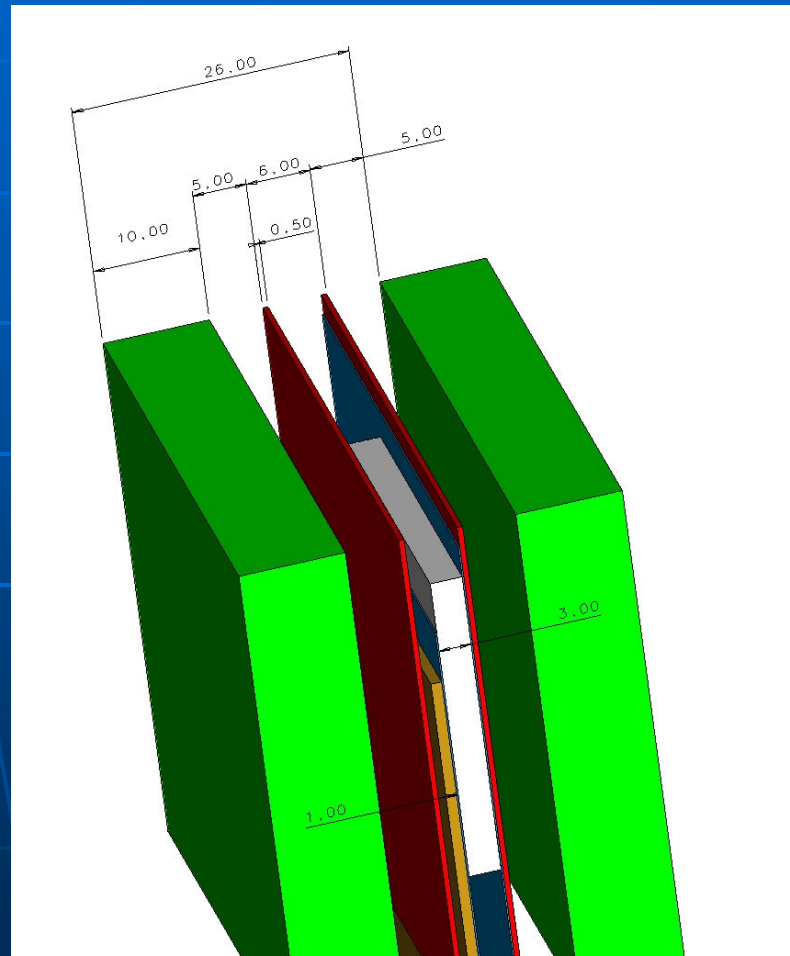



# new front end electronics

## The Next Generation

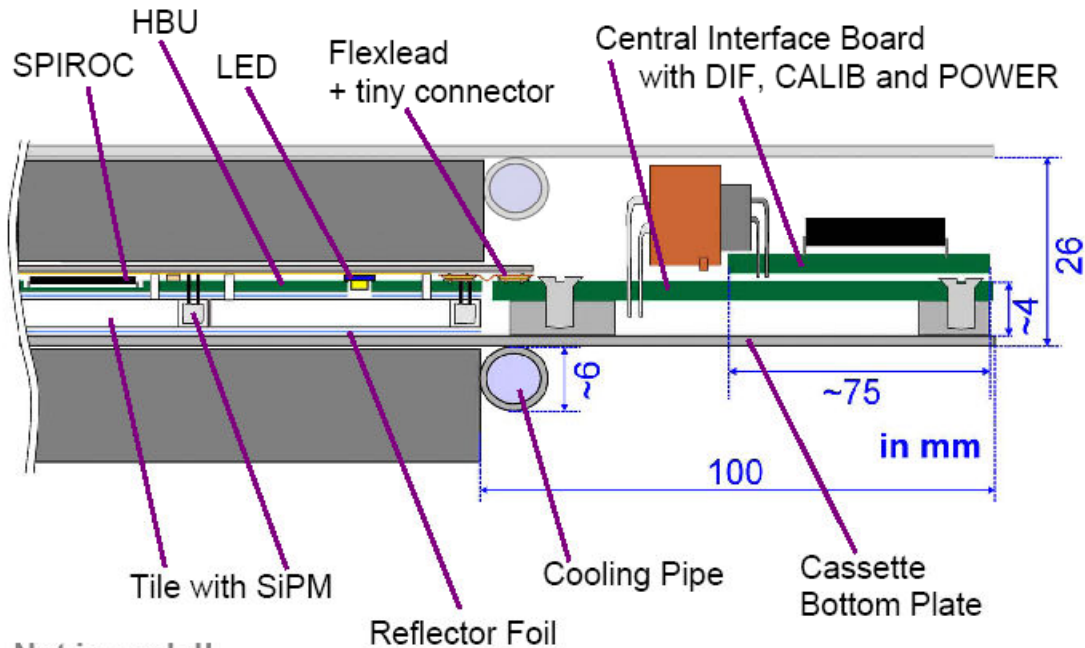

Mathias Reinecke | CALICE week Lyon | Sept. 16th – 18th, 2009 | Page 15

