



# Vizela's River Pollution

INTERNET OF NATURE

# Problem



- **Illegal discharges** – Domestic and Industrial
- Water Treatment Plants aren't reliable
- **Bad smell**
- Glyphosate, Female Hormones have been found in the water
- Funeral to Vizela's River





# Can you imagine...?

- Sensors to **monitor** and **track** pollution
- Knowing who is responsible
- **Real time** for **everyone**
- **Educate** and alert people





# Food Preservation

COOLBA



# Problem

- Of **all the food** we produce, 45% is wasted
- 50% of the wasted food happens during **handling** and **transportation**
- 70% of food preservation is guaranteed by **good temperature conditions**



# Can you imagine...?



- **Slow down maturation** process
- 70% of food preservation is guaranteed by **good temperature** conditions
- Reduce water consumption



# Can you imagine...?



## - Integrated CO<sub>2</sub> Cooling System

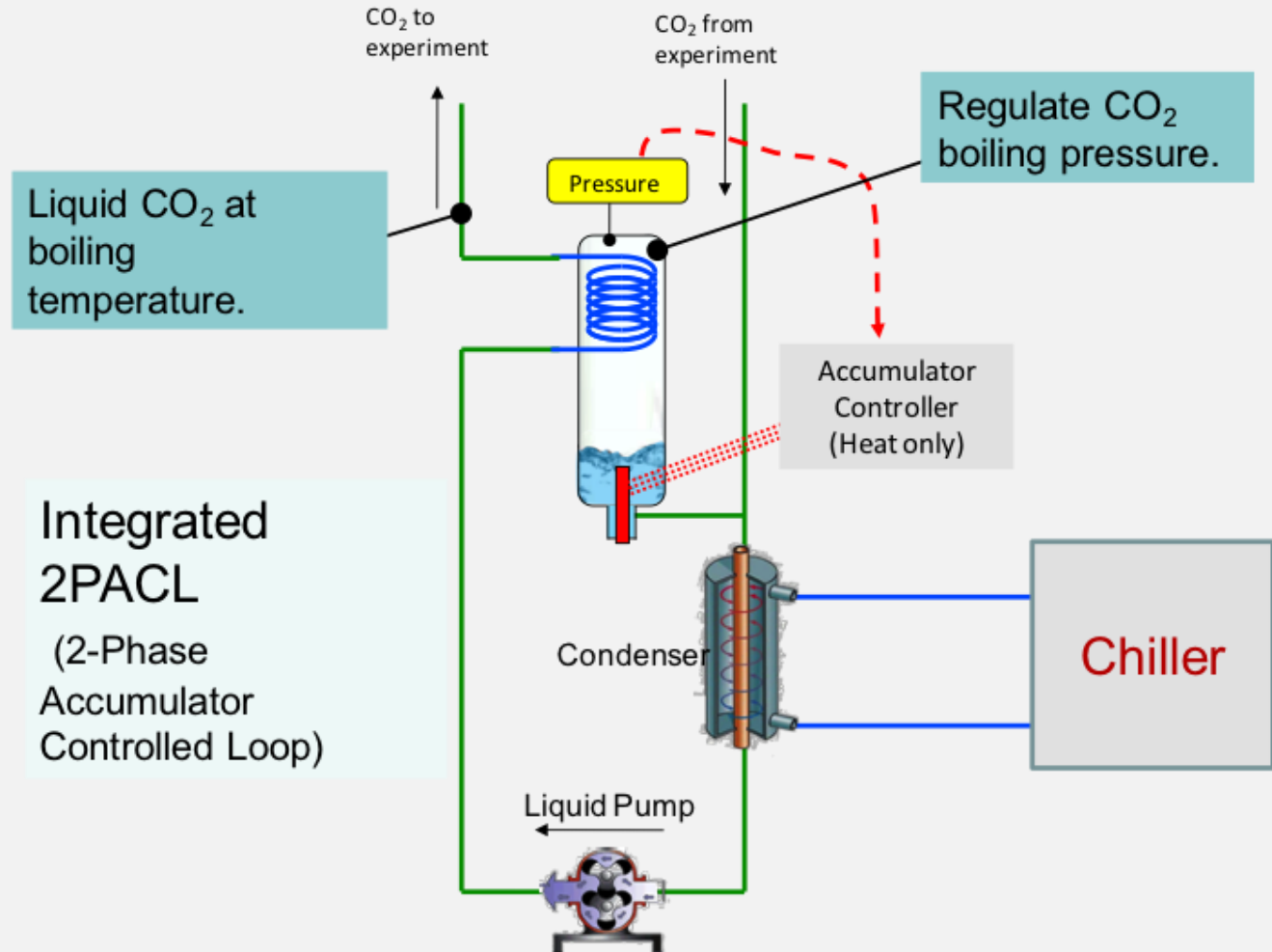



THANK YOU.

João Paço

Luís Barbosa

Sara Cláudio