

JUAS 2018, Archamps, France

Tutorial on Gas Flow, Conductance, Pressure Profiles

R. Kersevan, TE/VSC-VSM - CERN, Geneva

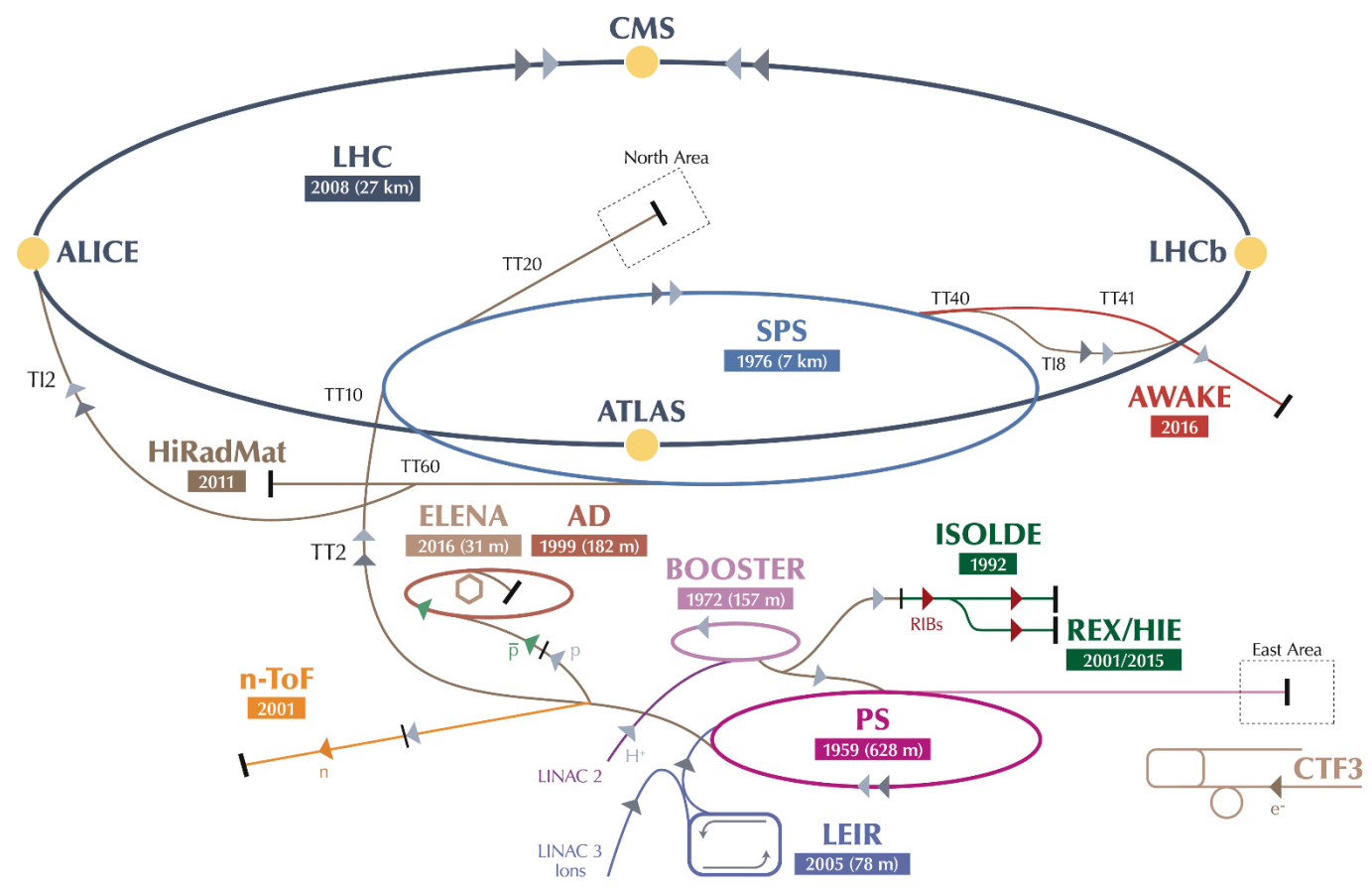



Content:

- Concepts of gas flow, conductance, pressure profile as relevant to the design of the vacuum system of modern accelerators;
- A quick definition of the terms involved;
- Some computational models and algorithms: analytical vs numerical;
- Simple exercises (if times allows)
- Summary;

Tutorial on Gas Flow, Conductance, Pressure Profiles

- Sources: “[1] **Fundamentals of Vacuum Technology**”, Oerlikon-Leybold (*);
[2] “**Vacuum Technology**”, A. Roth, Elsevier;
[3] “**A User’s Guide to Vacuum Technology**”, J.F. O’Hanlon, Wiley-Interscience;
[4] “**Vacuum Engineering Calculations, Formulas, and Solved Exercises**”, A. Berman, Academic Press;

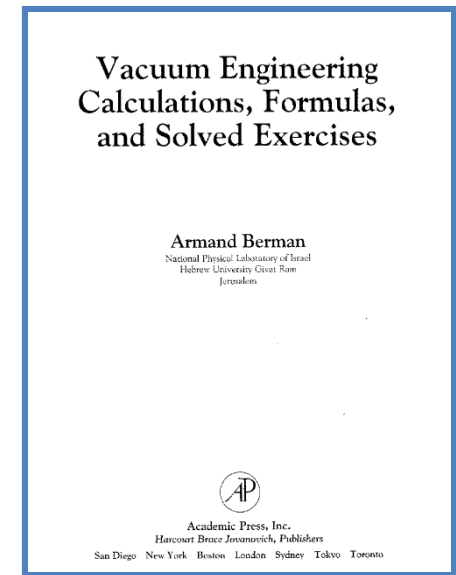
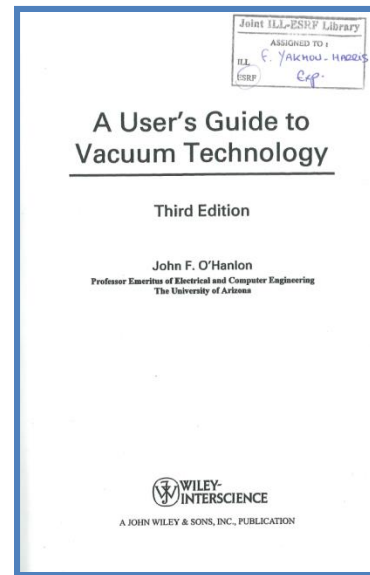
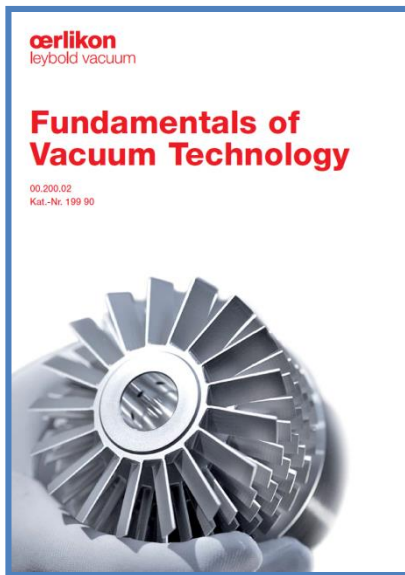

(*) Not endorsing products of any kind or brand

Tutorial on Gas Flow, Conductance, Pressure Profiles

Sources: [5] "Handbook of Vacuum Technology", K. Jousten ed., Wiley-Vch, 1002 p.

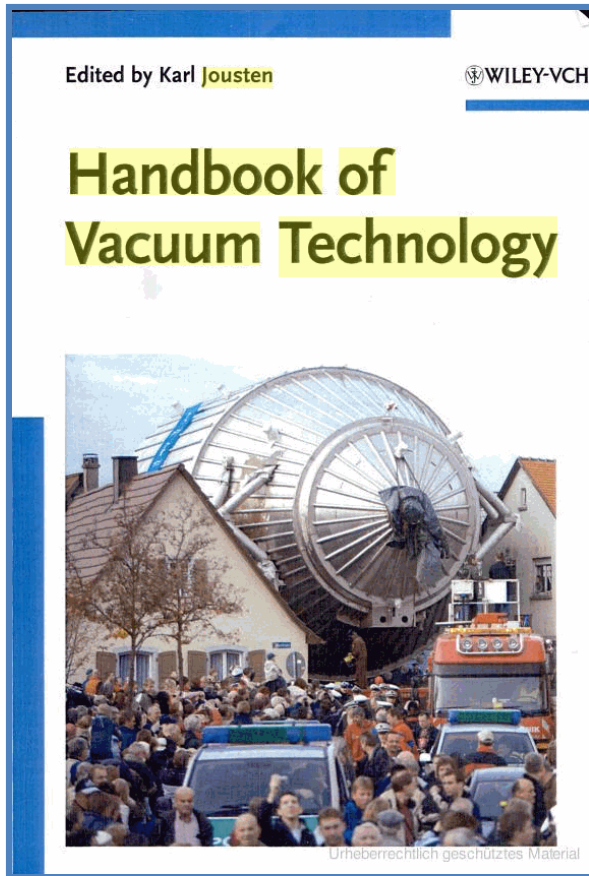

VI Contents

- 3.5 Vapors 71
 - 3.5.1 Saturation Vapor Pressure 71
 - 3.5.2 Evaporation Rate 74
 - References 72
- 4 Gas Flow 79
 - 4.1 Types of Flow, Definitions 79
 - 4.1.1 Characterizing Flow, Knudsen Number, Reynolds Number 79
 - 4.1.2 Gas Flow, Throughput, Pumping Speed 83
 - 4.1.3 Flow Resistance, Flow Conductance 87
 - 4.1.4 Effective Pumping Speed of a Vacuum Pump 88
 - 4.2 Inviscid Viscous Flow, Gas Dynamics 90
 - 4.2.1 Conservation Laws 90
 - 4.2.2 Gradual Change of Cross-sectional Area: Isentropic Change of State 91
 - 4.2.3 Critical Flow 94
 - 4.2.4 Choked Flow at Low Outlet Pressure 96
 - 4.2.5 Contraction of Flow into Aperture and Tube 98
 - 4.2.6 Examples of Nozzle Flow 98
 - 4.2.7 Straight and Oblique Compression Shocks 102
 - 4.2.8 Laval Nozzle, Effluent Flow against Counterpressure 105
 - 4.2.9 Flow around a Corner (Prandtl-Meyer Flow) 107
 - 4.3 Frictional-Viscous Flow through a Tube 110
 - 4.3.1 Laminar and Turbulent Flow through a Tube 110
 - 4.3.2 Airflow through a Tube 114
 - 4.3.3 Air Inflow to a Vessel, Examples 117
 - 4.3.4 Tube at the Inlet of a Pump, Examples 121
 - 4.3.5 Flow through Ducts with Non-circular Cross Sections 124
 - 4.3.6 Influence of Gas Species on Flow 126
 - 4.4 Molecular Flow under High-vacuum and Ultrahigh-vacuum Conditions 127
 - 4.4.1 Flow Pattern, Definitions, Transmission Probability 127
 - 4.4.2 Molecular Flow through an Aperture 131
 - 4.4.3 Molecular Flow through a Tube with Constant Cross-sectional Area 133
 - 4.4.4 Molecular Flow through a Tube with Circular Cross Section 135
 - 4.4.5 Molecular Flow through Tubes with Simple Cross-sectional Geometry 136
 - 4.4.6 Tube Bend and Tube Elbow 138
 - 4.4.7 Series Connection of Tube and Aperture 141
 - 4.4.8 Series Connection of Components 142
 - 4.4.9 Molecular Flow through Conical Tube with Circular Cross Section (Funnel) 145
 - 4.4.10 Component in the Inlet Line of a Pump 146

Contents VII

- 4.5 Flow throughout the Entire Pressure Range 147
 - 4.5.1 Flow Ranges 147
 - 4.5.2 Flow through a Thin Aperture with Circular Cross Section 147
 - 4.5.3 Flow through a Long Tube with Circular Cross Section 150
 - 4.6 Flow with Temperature Difference, Thermal Effusion, Transpiration 154
 - 4.7 Measuring Flow Conductances 158
 - 4.7.1 Necessity of Measurement 158
 - 4.7.2 Measurement of Intrinsic Conductances (Inherent Conductances) 158
 - 4.7.3 Calculation of Reduced Conductance (Assembly Conductance) 160
 - 4.7.4 Measuring Reduced Conductances 160
 - References 162
 - Further Reading 162
- 5 Analytical and Numerical Calculations of Rarefied Gas Flows 163
 - 5.1 Main Concepts 163
 - 5.1.1 Knudsen Number and Gas Rarefaction 163
 - 5.1.2 Macroscopic Quantities 164
 - 5.1.3 Velocity Distribution Function 164
 - 5.1.4 Global Equilibrium 165
 - 5.1.5 Local Equilibrium 166
 - 5.1.6 Boltzmann Equation 166
 - 5.1.7 Transport Coefficients 168
 - 5.1.8 Model Equations 170
 - 5.1.9 Gas-surface Interaction 171
 - 5.2 Methods of Calculations of Gas Flows 174
 - 5.2.1 General Remarks 174
 - 5.2.2 Deterministic Methods 174
 - 5.2.3 Probabilistic Methods 176
 - 5.3 Velocity Slip and Temperature Jump Phenomena 178
 - 5.3.1 Viscous Slip Coefficient 178
 - 5.3.2 Thermal Slip Coefficient 180
 - 5.3.3 Temperature Jump Coefficient 181
 - 5.4 Momentum and Heat Transfer Through Rarefied Gases 182
 - 5.4.1 Plane Couette Flow 182
 - 5.4.2 Cylindrical Couette Flow 184
 - 5.4.3 Heat Transfer Between Two Plates 187
 - 5.4.4 Heat Transfer Between Two Coaxial Cylinders 190
 - 5.5 Flows Through Long Pipes 193
 - 5.5.1 Definitions 194
 - 5.5.2 Free-molecular Regime 195
 - 5.5.3 Slip Flow Regime 196

KATRIN neutrino mass experiment: a very sophisticated vacuum system (cryogenic system with e^- -guiding solenoids integrated into the cryostats, plus turbo pumps to decrease the source-to-detector transmission probability, and more...); Fully analysed, mand modelled via Test-Particle Monte Carlo (TPMC) simulations
Deconstruction: KATRIN's odyssey

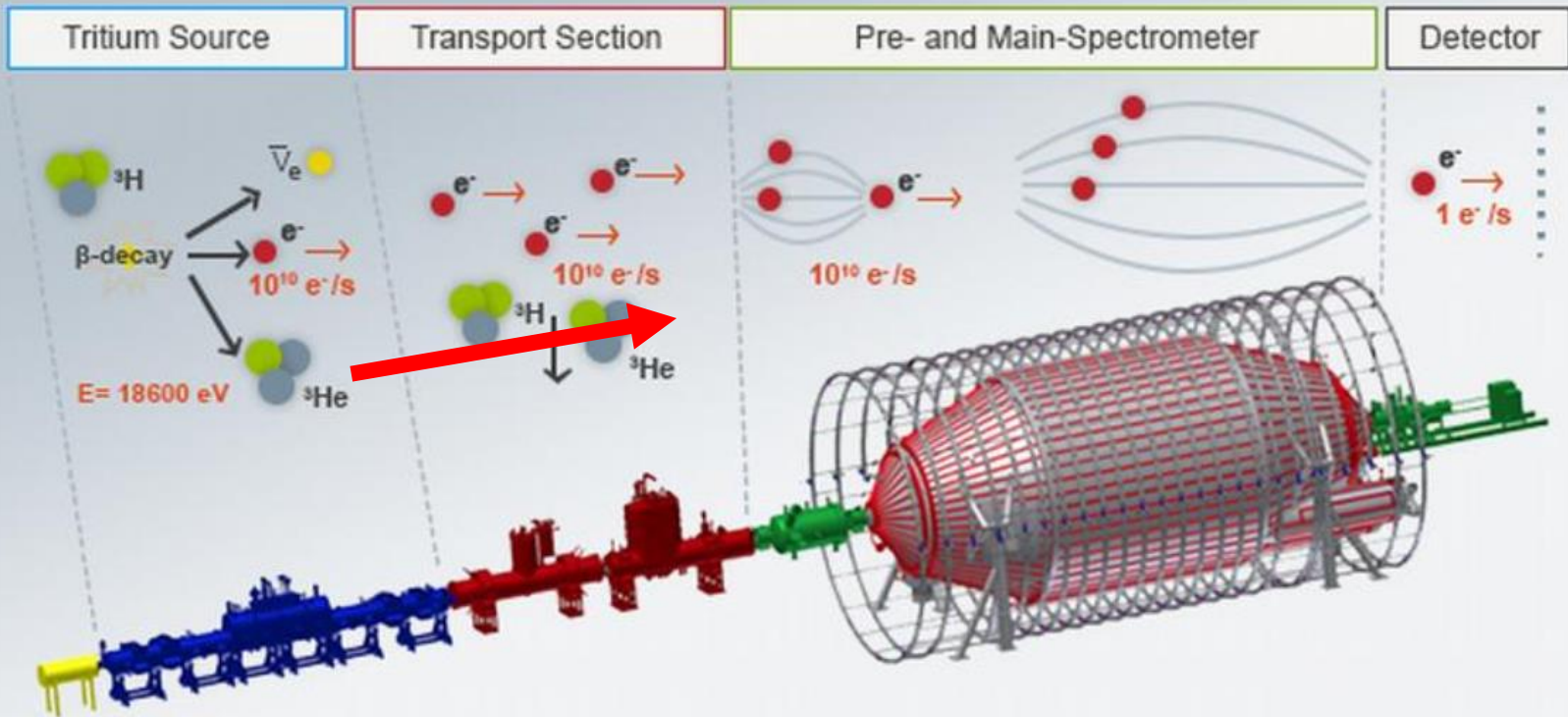

Tritium decays, releasing an electron and an anti-electron-neutrino. While the neutrino escapes undetected, the electron starts its journey to the detector.

Electrons are guided towards the spectrometer by magnetic fields. Tritium has to be pumped out to provide tritium free spectrometers.

The electron energy is analyzed by applying an electrostatic retarding potential. Electrons are only transmitted if their kinetic energy is sufficiently high.

At the end of their journey, the electrons are counted at the detector. Their rate varies with the spectrometer potential and hence gives an integrated β -spectrum.

Tutorial on Gas Flow, Conductance, Pressure Profiles

Units and Definitions

Unit	$\text{N} \cdot \text{m}^{-2}$, Pa ²⁾	mbar	bar	Torr
1 $\text{N} \cdot \text{m}^{-2}$ (= 1 Pa)	1	$1 \cdot 10^{-2}$	$1 \cdot 10^{-5}$	$7.5 \cdot 10^{-3}$
1 mbar	100	1	$1 \cdot 10^{-3}$	0.75
1 bar	$1 \cdot 10^5$	1 · 103	1	750
1 Torr ³⁾	133	1.33	$1.33 \cdot 10^{-3}$	1

1) The torr is included in the table only to facilitate the transition from this familiar unit to the statutory units $\text{N} \cdot \text{m}^{-2}$, mbar and bar. In future the pressure units torr, mm water column, mm mercury column (mm Hg), % vacuum, technical atmosphere (at), physicalatmosphere (atm), atmosphere absolute (ata), pressure above atmospheric and pressure below atmospheric may no longer be used. Reference is made to DIN 1314 in this context.

2) The unit Newton divided by square meters ($\text{N} \cdot \text{m}^{-2}$) is also designated as Pascal (Pa): $1 \text{ N} \cdot \text{m}^{-2} = 1 \text{ Pa}$.

Newton divided by square meters or Pascal is the SI unit for the pressure of fluids.

3) 1 torr = 4/3 mbar; fl torr = 1 mbar.

Table I: Permissible pressure units including the torr 1) and its conversion

Abbrev.	Gas	$C^* = \lambda \cdot p$ [cm · mbar]
H ₂	Hydrogen	$12.00 \cdot 10^{-3}$
He	Helium	$18.00 \cdot 10^{-3}$
Ne	Neon	$12.30 \cdot 10^{-3}$
Ar	Argon	$6.40 \cdot 10^{-3}$
Kr	Krypton	$4.80 \cdot 10^{-3}$
Xe	Xenon	$3.60 \cdot 10^{-3}$
Hg	Mercury	$3.05 \cdot 10^{-3}$
O ₂	Oxygen	$6.50 \cdot 10^{-3}$
N ₂	Nitrogen	$6.10 \cdot 10^{-3}$
HCl	Hydrochloric acid	$4.35 \cdot 10^{-3}$
CO ₂	Carbon dioxide	$3.95 \cdot 10^{-3}$
H ₂ O	Water vapor	$3.95 \cdot 10^{-3}$
NH ₃	Ammonia	$4.60 \cdot 10^{-3}$
C ₂ H ₅ OH	Ethanol	$2.10 \cdot 10^{-3}$
Cl ₂	Chlorine	$3.05 \cdot 10^{-3}$
Air	Air	$6.67 \cdot 10^{-3}$

Table III: Mean free path l

Values of the product c^* of the mean free path λ (and pressure p for various gases at 20 °C (see also Fig. 9.1)

1 ↓ = ... →	mbar	Pa (N/m ³)	dyn · cm ⁻² (μbar)	atm (phys.)	Torr (mm Hg)	inch Hg	Micron (μ)	cm H ₂ O	kp · cm ⁻² (at tech.)	lb · in ⁻² (psi)	lb · ft ⁻²
mbar	1	10 ²	10 ³	$9.87 \cdot 10^{-4}$	0.75	$2.953 \cdot 10^{-2}$	$7.5 \cdot 10^2$	1.02	$1.02 \cdot 10^{-3}$	$1.45 \cdot 10^{-2}$	2.089
Pa	10 ⁻²	1	10	$9.87 \cdot 10^{-6}$	$7.5 \cdot 10^{-3}$	$2.953 \cdot 10^{-4}$	7.5	$1.02 \cdot 10^{-2}$	$1.02 \cdot 10^{-5}$	$1.45 \cdot 10^{-4}$	$2.089 \cdot 10^{-2}$
μbar	10 ⁻³	0.1	1	$9.87 \cdot 10^{-7}$	$7.5 \cdot 10^{-4}$	$2.953 \cdot 10^{-5}$	$7.5 \cdot 10^{-1}$	$1.02 \cdot 10^{-3}$	$1.02 \cdot 10^{-6}$	$1.45 \cdot 10^{-5}$	$2.089 \cdot 10^{-3}$
atm	1013	$1.01 \cdot 10^5$	$1.01 \cdot 10^6$	1	760	29.92	$7.6 \cdot 10^5$	$1.03 \cdot 10^3$	1.033	14.697	2116.4
Torr	1.33	$1.33 \cdot 10^2$	$1.33 \cdot 10^3$	$1.316 \cdot 10^{-3}$	1	$3.937 \cdot 10^{-2}$	10 ³	1.3595	$1.36 \cdot 10^{-3}$	$1.934 \cdot 10^{-2}$	2.7847
in Hg	33.86	$33.9 \cdot 10^2$	$33.9 \cdot 10^3$	$3.342 \cdot 10^{-2}$	25.4	1	$2.54 \cdot 10^4$	34.53	$3.453 \cdot 10^{-2}$	0.48115	70.731
μ	$1.33 \cdot 10^{-3}$	$1.33 \cdot 10^{-1}$	1.333	$1.316 \cdot 10^{-6}$	10 ⁻³	$3.937 \cdot 10^{-5}$	1	$1.36 \cdot 10^{-3}$	$1.36 \cdot 10^{-6}$	$1.934 \cdot 10^{-5}$	$2.785 \cdot 10^{-3}$
cm H ₂ O	0.9807	98.07	980.7	$9.678 \cdot 10^{-4}$	0.7356	$2.896 \cdot 10^{-2}$	$7.36 \cdot 10^2$	1	10 ⁻³	$1.422 \cdot 10^{-2}$	2.0483
at	$9.81 \cdot 10^2$	$9.81 \cdot 10^4$	$9.81 \cdot 10^5$	0.968	$7.36 \cdot 10^2$	28.96	$7.36 \cdot 10^5$	103	1	14.22	2048.3
psi	68.95	$68.95 \cdot 10^2$	$68.95 \cdot 10^3$	$6.804 \cdot 10^{-2}$	51.71	2.036	$51.71 \cdot 10^3$	70.31	$7.03 \cdot 10^{-2}$	1	$1.44 \cdot 10^2$
lb · ft ⁻²	0.4788	47.88	478.8	$4.725 \cdot 10^{-4}$	0.3591	$1.414 \cdot 10^{-2}$	359.1	0.488	$4.88 \cdot 10^{-4}$	$6.94 \cdot 10^{-3}$	1

Normal conditions: 0 °C and sea level, i.e. $p = 1013 \text{ mbar} = 760 \text{ mm Hg} = 760 \text{ torr} = 1 \text{ atm}$

in Hg = inches of mercury; 1 mtorr (millitorr) = 10^{-3} torr = 1 μ (micron ... μm Hg column)

Pounds per square inch = $\text{lb} \cdot \text{in}^{-2} = \text{lb} / \text{sqin} = \text{psi}$ (psig = psi gauge ... pressure above atmospheric, pressure gauge reading; psia = psi absolute ... absolute pressure)

Pounds per square foot = $\text{lb} / \text{sqft} = \text{lb} / \text{ft}^2$; $\text{kgf}/\text{sqcm}^2 = \text{kg force per square cm} = \text{kp} / \text{cm}^2 = \text{at}$; analogously also: $\text{lbf} / \text{sqin} = \text{psi}$

1 dyn · cm⁻² (cgs) = 1 μbar (microbar) = 1 barye; 1 bar = 0.1 Mpa; 1 cm water column (cm water column = g / cm^2 at 4 °C) = 1 Ger (Geryk)

atm ... physical atmosphere – at ... technical atmosphere; 100 - (x mbar / 10.13) = y % vacuum

Table II: Conversion of pressure units

Units and Definitions [2]

- Without bothering Democritus, Aristoteles, Pascal, Torricelli et al... a modern definition of "vacuum" is the following (American Vacuum Society, 1958):

"... a given space or volume filled with gas at pressures below atmospheric pressure"

- Keeping this in mind, the following curve [2] defines the molecular density vs pressure and the mean free path (MFP), a very important quantity:

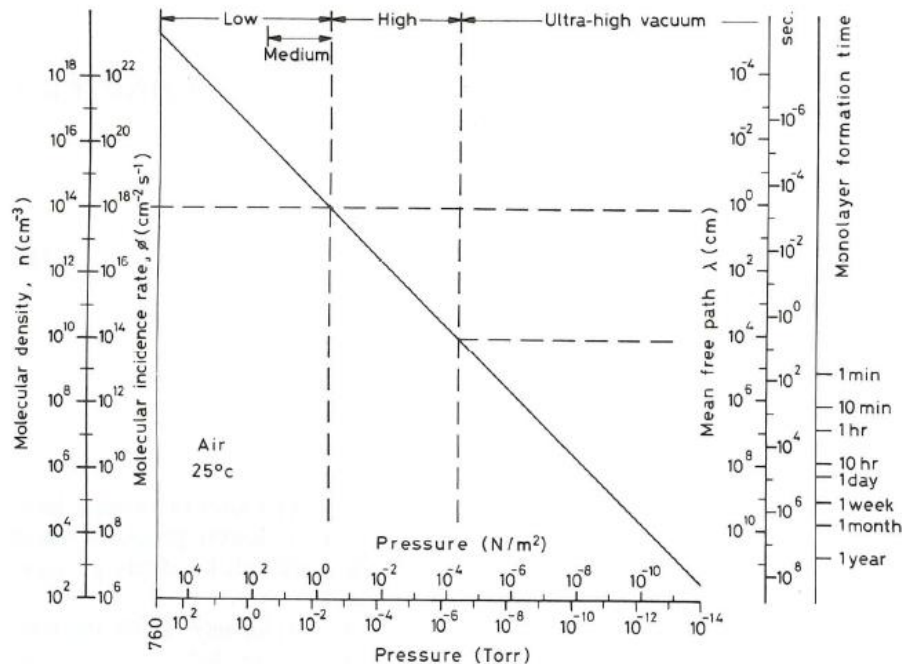

Fig. 1.1 Relationship of several concepts defining the degree of vacuum.

Mean-free path: average distance travelled by a molecule before hitting another one (ternary, and higher-order, collisions are negligible)
 The importance of obtaining a low pressure, in accelerators, is evident:

- reduce collisions between the particle beams and the residual gas;
- increase beam lifetime;
- reduce losses;
- reduce activation of components;
- reduce doses to personnel;
- decrease number of injection cycles;
- improve beam up-time statistics;
- more..

Tutorial on Gas Flow, Conductance, Pressure Profiles

Units and Definitions [3]

• A different view can be found here...

<http://hyperphysics.phy-astr.gsu.edu/hbase/kinetic/menfre.html>

Mean Free Path Perspective

You may be surprised by the length of the mean free path compared to the average molecular separation in an ideal gas. An atomic size of 0.3 nm was assumed to calculate the other distances.

Model of an ideal gas at STP (760 mmHg pressure, 0°C)

The mean free path is 310 times the nominal atomic diameter and 28 times the average molecular separation.

Perspective of mean free path compared to average molecular separation. (Individual molecules are exaggerated in size by a factor of about 5)

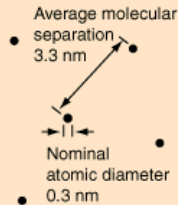
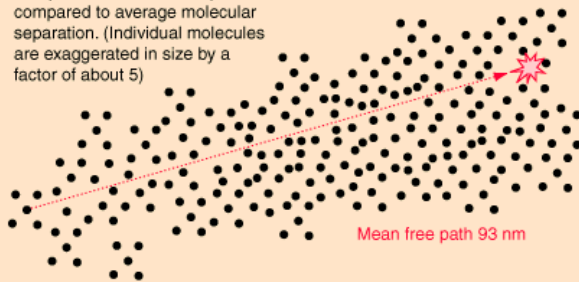

Perspective of molecular size compared to average molecular separation.

The average molecular separation is about 10x the atomic diameter.

[Mean Free Path Calculation](#) [Frequency of collision](#)

Gas	$\lambda \cdot p$ (m·Pa)	Gas	$\lambda \cdot p$ (m·Pa)
H ₂	11.5x10 ⁻³	CO ₂	4.0x10 ⁻³
N ₂	5.9x10 ⁻³	Ar	6.4x10 ⁻³
He	17.5x10 ⁻³	Ne	12.7x10 ⁻³
CO	6.0x10 ⁻³	Kr	4.9x10 ⁻³

Mean Free Path λ (m) vs Pressure (Pa), T=293.15 °K

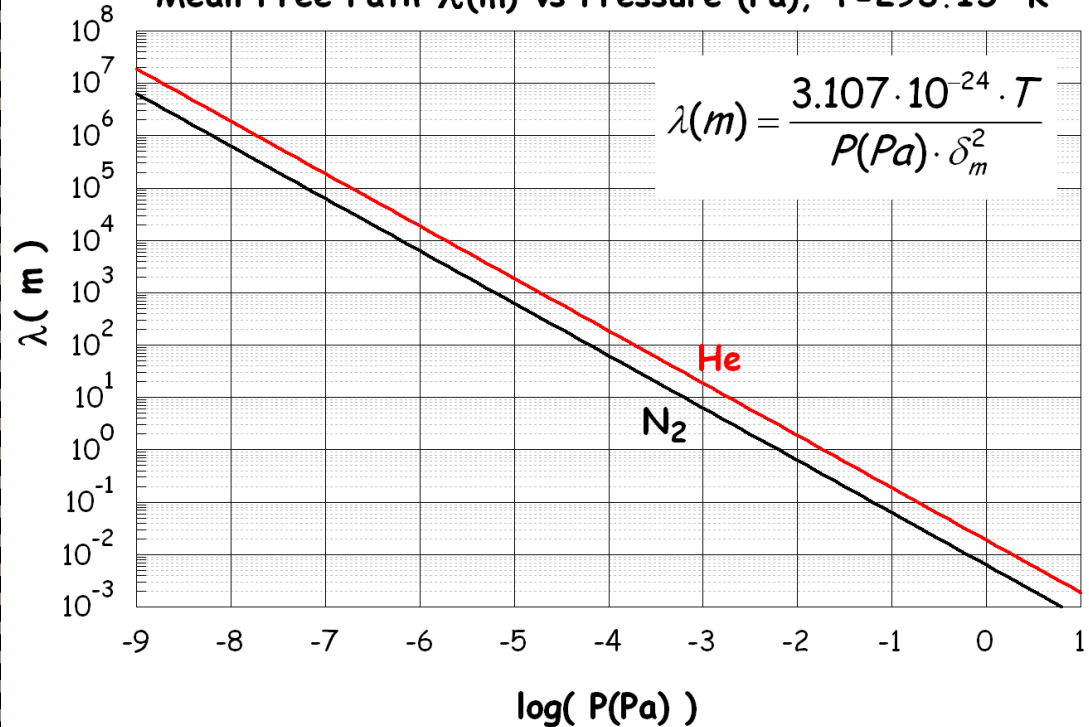

More molecular dimensions, δ_m , can be found here:

http://www.kayelaby.npl.co.uk/general_physics/2_2/2_4.html

Tutorial on Gas Flow, Conductance, Pressure Profiles

Units and Definitions [4]

Definition of “flow regime”

The so-called “Knudsen number” is defined as this:

$$Kn = \frac{\lambda}{D}$$

And the different flow (pressure) regimes are identified as follows:

FREE MOLECULAR FLOW : $Kn > 1$
TRANSITIONAL FLOW : $0.01 < Kn < 1$
CONTINUUM (VISCOUS) FLOW: $Kn < 0.01$

Practically all accelerators work in the free-molecular regime i.e. in a condition where the MFP λ is bigger than the “typical” dimension of the vacuum chamber (e.g.its diameter), and therefore molecular collisions can be neglected.

82 | 4 Gas Flow

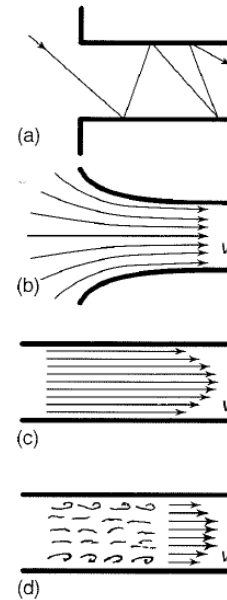

Fig. 4.2 Different types of gas flow. Top: molecular flow. Below and further down: different types of viscous flow: gas-dynamic (intake flow), laminar, and turbulent.

IMPORTANT: in molecular flow regime, the absence of collisions between molecules translates into the fact that high-vacuum pumps DO NOT “SUCK” GASES, they simply generate some probability s that once a molecule enters into the pump it is permanently removed from the system. s can be identified as the equivalent sticking coefficient.

Units and Definitions [5]

Definition of “vacuum ranges”

- Linked to the Knudsen number and the flow regimes, historically defined as in table below [1]:

		Rough vacuum	Medium vacuum	High vacuum	Ultrahigh vacuum
Pressure	p [mbar]	1013 – 1	$1 - 10^{-3}$	$10^{-3} - 10^{-7}$	$< 10^{-7}$
Particle number density	n [cm ⁻³]	$10^{19} - 10^{16}$	$10^{16} - 10^{13}$	$10^{13} - 10^9$	$< 10^9$
Mean free path	λ [cm]	$< 10^{-2}$	$10^{-2} - 10$	$10 - 10^5$	$> 10^5$
Impingement rate	Z_a [cm ⁻² · s ⁻¹]	$10^{23} - 10^{20}$	$10^{20} - 10^{17}$	$10^{17} - 10^{13}$	$< 10^{13}$
Vol.-related collision rate	Z_v [cm ⁻³ · s ⁻¹]	$10^{29} - 10^{23}$	$10^{23} - 10^{17}$	$10^{17} - 10^9$	$< 10^9$
Monolayer time	τ [s]	$< 10^{-5}$	$10^{-5} - 10^{-2}$	$10^{-2} - 100$	> 100
Type of gas flow		Viscous flow	Knudsen flow	Molecular flow	Molecular flow
Other special features		Convection dependent on pressure	Significant change in thermal conductivity of a gas	Significant reduction in volume related collision rate	Particles on the surfaces dominate to a great extent in relation to particles in gaseous space

Table IX: Pressure ranges used in vacuum technology and their characteristics (numbers rounded off to whole power of ten)

- With the invention of very low-outgassing materials and treatments (e.g. NEG-coating), “Ultrahigh vacuum” (UHV) is sometimes split up into “UHV” and “XHV” (eXtreme High Vacuum) regimes

Table 4
Classification of vacuum ranges [8].

Vacuum Ranges	Pressure Units			
	Pa		mbar	
	min	max	min	max
Low (LV)	3.3×10^3	1.0×10^5	3.3×10	1.0×10^3
Medium (MV)	1.0×10^{-1}	3.3×10^3	1.0×10^{-3}	3.3×10
High (HV)	1.0×10^{-4}	1.0×10^{-1}	1.0×10^{-6}	1.0×10^{-3}
Very High (VHV)	1.0×10^{-7}	1.0×10^{-4}	1.0×10^{-9}	1.0×10^{-6}
Ultra-High (UHV)	1.0×10^{-10}	1.0×10^{-7}	1.0×10^{-12}	1.0×10^{-9}
Extreme Ultra-High (XHV)	$\leq 1.0 \times 10^{-10}$		$\leq 1.0 \times 10^{-12}$	

- (Ref. N. Marquardt, CERN CAS 1999) 

Tutorial on Gas Flow, Conductance, Pressure Profiles

Impingement and Collision rates; Ideal Gas Law

• Impingement rate and collision rates

VARIABLE	General formula	For easy calculation	Value for air at 20 °C
Most probable speed of particles c_w	$c_w = \sqrt{\frac{2 \cdot R \cdot T}{M}}$	$c_w = 1.29 \cdot 10^4 \sqrt{\frac{T}{M}} \left[\frac{\text{cm}}{\text{s}} \right]$	$c_w = 410 \text{ [m/s]}$
Mean velocity of particles \bar{c}	$\bar{c} = \sqrt{\frac{8 \cdot R \cdot T}{\pi \cdot M}}$	$\bar{c} = 1.46 \cdot 10^4 \sqrt{\frac{T}{M}} \left[\frac{\text{cm}}{\text{s}} \right]$	$\bar{c} = 464 \text{ [m/s]}$
Mean square of velocity of particles \bar{c}^2	$\bar{c}^2 = \frac{3 \cdot R \cdot T}{M}$	$\bar{c}^2 = 2.49 \cdot 10^8 \frac{T}{M} \left[\frac{\text{cm}^2}{\text{s}^2} \right]$	$\bar{c}^2 = 25.16 \cdot 10^6 \left[\frac{\text{cm}^2}{\text{s}^2} \right]$
Gas pressure p of particles	$p = \frac{1}{3} \cdot n \cdot m \cdot \bar{c}^2$ $p = \frac{1}{3} \cdot n \cdot M \cdot \bar{c}^2$	$p = 13.80 \cdot 10^{-20} \cdot n \cdot T \text{ [mbar]}$	$p = 4.04 \cdot 10^{-17} \cdot n \text{ [mbar]}$ (applies to all gases)
Number density of particles n	$n = p/kT$	$n = 7.25 \cdot 10^{18} \frac{p}{T} \text{ [cm}^{-3}\text{]}$	$n = 2.5 \cdot 10^{16} \cdot p \text{ [cm}^{-3}\text{]}$ (applies to all gases)
Area-related impingement Z_A	$Z_A = \frac{1}{4} \cdot n \cdot \bar{c}$ $Z_A = \sqrt{\frac{N_A}{2 \cdot \pi \cdot M \cdot k \cdot T}} \cdot p$	$Z_A = 2.63 \cdot 10^{22} \frac{p}{\sqrt{M \cdot T}} \text{ [cm}^{-2} \text{ s}^{-1}\text{]}$	$Z_A = 2.85 \cdot 10^{20} \cdot p \text{ [cm}^{-2} \text{ s}^{-1}\text{]}$ (see Fig. 78.2)
Volume collision rate Z_V	$Z_V = \frac{1}{2} \frac{n \cdot \bar{c}}{\lambda}$ $Z_V = \frac{1}{\bar{c}^2} \sqrt{\frac{2 \cdot N_A}{\pi \cdot M \cdot k \cdot T}} \cdot p^2$	$Z_V = 5.27 \cdot 10^{22} \frac{p^2}{c^2 \cdot \sqrt{M \cdot T}} \text{ [cm}^{-3} \text{ s}^{-1}\text{]}$	$Z_V = 8.6 \cdot 10^{22} \cdot p^2 \text{ [cm}^{-3} \text{ s}^{-1}\text{]}$ (see Fig. 78.2)
Equation of state of ideal gas	$p \cdot V = n \cdot R \cdot T$		(gases)
Area-related mass flow rate $q_{m,A}$	$q_{m,A} = Z_A \cdot M$		

$c^* = \lambda \cdot p$ in $\text{cm} \cdot \text{mbar}$ (see Tab. III)
 k - Boltzmann constant in $\text{mbar} \cdot \text{l} \cdot \text{K}^{-1}$
 λ - mean free path in cm
 M - molar mass in $\text{g} \cdot \text{mol}^{-1}$

Table IV: Compilation of important formulas pertaining

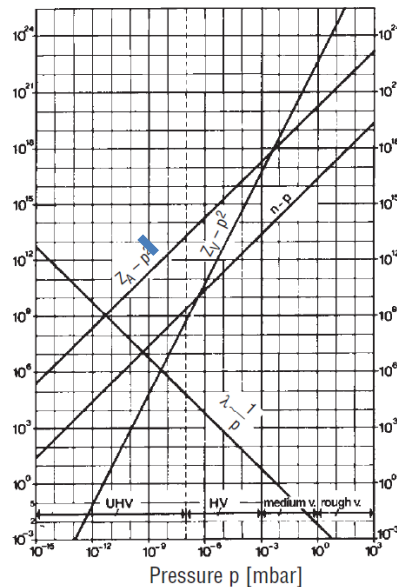

λ : mean free path in cm ($\lambda \sim 1/p$)
 n : particle number density in cm^{-3} ($n \sim p$)
 Z_A : area-related impingement rate in $\text{cm}^{-2} \cdot \text{s}^{-1}$ ($Z_A \sim p^2$)
 Z_V : volume-related collision rate in $\text{cm}^{-3} \cdot \text{s}^{-1}$ ($Z_V \sim p^2$)

Fig. 9.2: Diagram of kinetics of gases for air at 20 °C

- The ideal gas law states that the pressure P of a diluted gas is given by

$$PV = \frac{m}{M} RT = n_M RT = n_M N_A k_B T$$

... where:

V = volume, m^3 ; m = mass of gas, kg

M = molecular mass, kg/mole

T = absolute temperature, $^\circ\text{K}$

R = gas constant = 8.31451 J/mol/K

n_M = number of moles

N_A = Avogadro's number = $6.022\text{E}+23$ molecules/mole

k_B = Boltzmann's constant = $1.381\text{E}-23$ J/K

- Deviation from this law are taken care of by introducing higher-order terms, the so called virial expansion,...

$$PV = RT(1 + BP + CP^2 + \dots)$$

... which are not discussed here.

Volumetric Flow Rate - Throughput - Basic Equations - Conductance

How does all this translates into "accelerator vacuum"?

- Let's imagine the simplest vacuum system, a straight tube with constant cross-section connecting two large volumes, $P_1 > P_2$

$$Q = P \cdot dV/dt$$

Q , which in the SI has the units of

$$[\text{Pa} \cdot \text{m}^3/\text{s}] \rightarrow [\text{N} \cdot \text{m} / \text{s}] = [\text{J}/\text{s}] = [\text{W}]$$

... is called the throughput. Therefore the throughput is the power carried by a gas flowing out (or in) of the volume V at a rate of dV/dt and pressure P .

- dV/dt is also called "volumetric flow rate", and when applied to the inlet of a pump, it is called "pumping speed".
- Therefore, we can also write a first basic equation of vacuum technology

$$Q = P \cdot S$$

- Having defined the throughput, we move now to the concept of conductance, C :

Suppose we have two volumes V_1 and V_2 , at pressures $P_1 > P_2$ respectively, connected via a tube

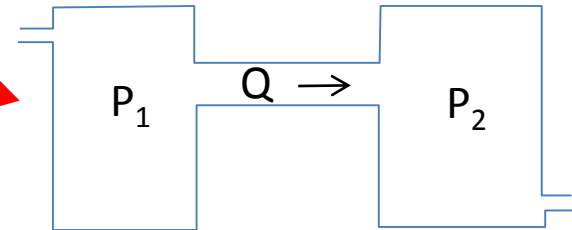

...we can define a second basic equation of vacuum technology

$$Q = C \cdot (P_1 - P_2) = C \cdot \Delta P$$

... which, making an electrical analogy...

$$I = V / R$$

... gives an obvious interpretation of C as the reciprocal of a resistance to flow.

The higher the conductance the more "current" (throughput) runs through the system.

Kinetic Theory of Gases

*How can conductances be calculated?
How does the dimension, shape, length,
etc... of a vacuum component define its
conductance?*

- We need to recall some concepts of kinetic theory of gases:
- The Maxwell-Boltzmann velocity distribution defines an ensemble of N molecules of given mass m and temperature T as

$$\frac{dn}{dv} = \frac{2N}{\pi^{1/2}} \left(\frac{m}{2kT} \right)^{3/2} v^2 e^{-m \cdot v^2 / (2 \cdot k_B \cdot T)}$$

... with n the molecular density, and k_b as before.

- The shape of this distribution for air at different temperatures, and for different gases at 25°C are shown on the right:

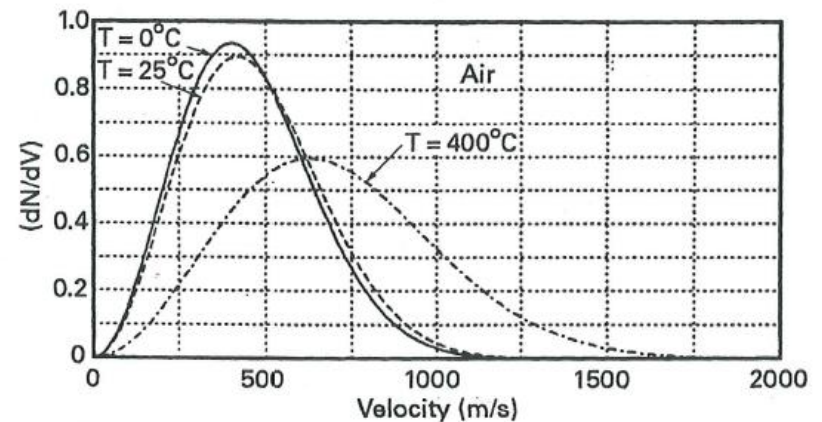

Fig. 2.1 Relative velocity distribution of air at 0°C, 25°C, and 400°C.

2.1 THE KINETIC PICTURE OF A GAS

11

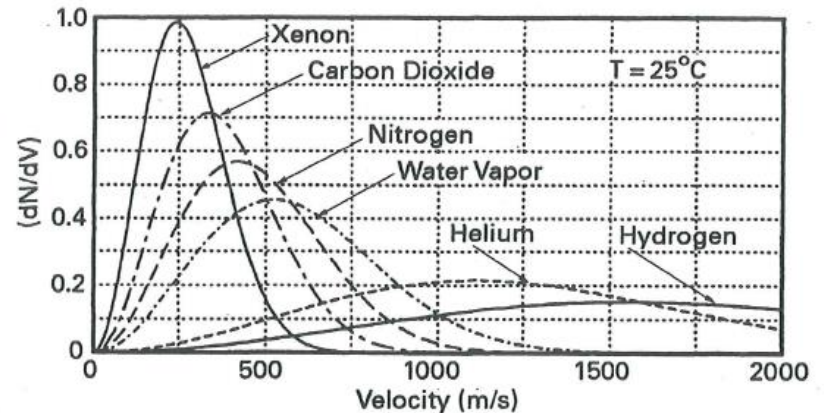

Fig. 2.2 Relative velocity distribution of several gases at 25°C.

Kinetic Theory of Gases [2]

- The kinetic theory of gases determines the mean, most probable, and rms velocity as:

$$v_{mp} = \sqrt{\frac{2RT}{M}}$$

$$v_{mean} = \sqrt{\frac{8RT}{\pi \cdot M}}$$

$$v_{rms} = \sqrt{\frac{3RT}{M}}$$

... with R the gas constant (J/°K/mole), M the molecular weight (kg/m³), and T the absolute temperature (°K).

Therefore, $v_{mp} < v_{mean} < v_{rms}$.

For air (M=29 g/mole) at 25°C these values are:

$$v_{mp} = 413 \text{ m/s}$$

$$v_{mean} = 467 \text{ m/s}$$

$$v_{rms} = 506 \text{ m/s}$$

For a gas with different M and T, these values scale as

$$\sqrt{\frac{M_{air}}{T_{air}}} \cdot \sqrt{\frac{T_{gas}}{M_{gas}}}$$

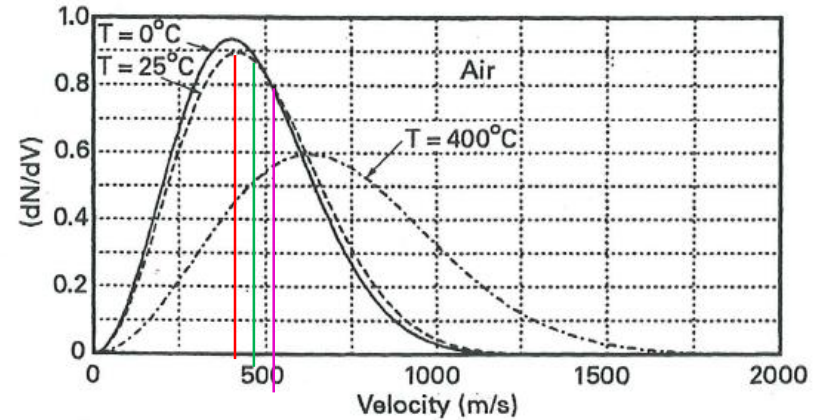

Fig. 2.1 Relative velocity distribution of air at 0°C, 25°C, and 400°C.

The energy distribution of the gas is

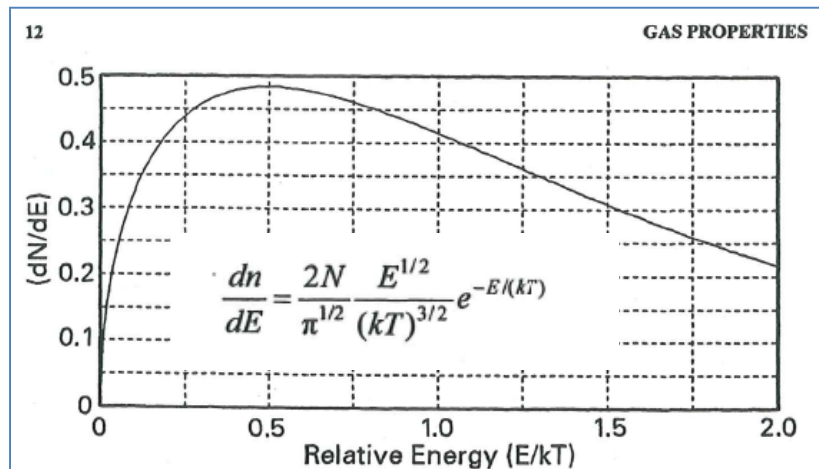

Fig. 2.3 Relative energy distribution of a gas at 25°C.

Transmission probability

- Within the kinetic theory of gases, it can be shown that the volumetric flow rate passing through an infinitely thin hole of surface area A between two volumes is given by

$$q = A \cdot \frac{v_{mean}}{4} \Delta P$$

... and by the analogy with the second basic equation we get that the conductance c of this thin hole is

$$c = A \cdot \frac{v_{mean}}{4}$$

For holes which are not of zero-thickness, a “reduction” factor k , $0 < k < 1$, can be defined. k is called transmission probability, and can be visualized as the effect of the “side wall” generated by the thickness.

It depends in a complicated way from the shape of the hole.

So, in general, for a hole of area A across a wall of thickness L

$$c(A, L) = A \cdot \frac{v_{mean}}{4} \cdot k(A, L)$$

Zero-thickness vs finite-thickness aperture in a wall...

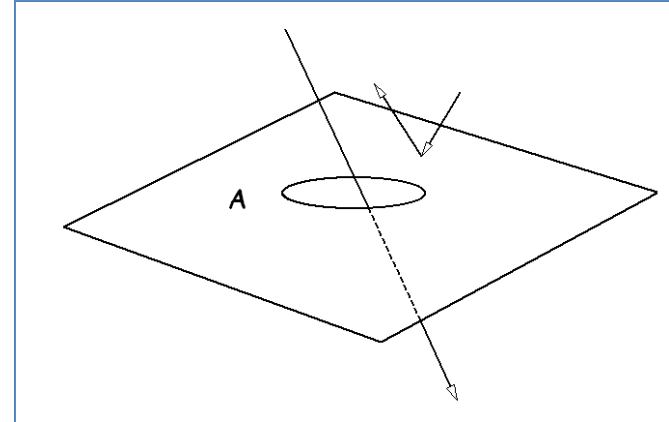

... the transmission probability decreases as L increases...

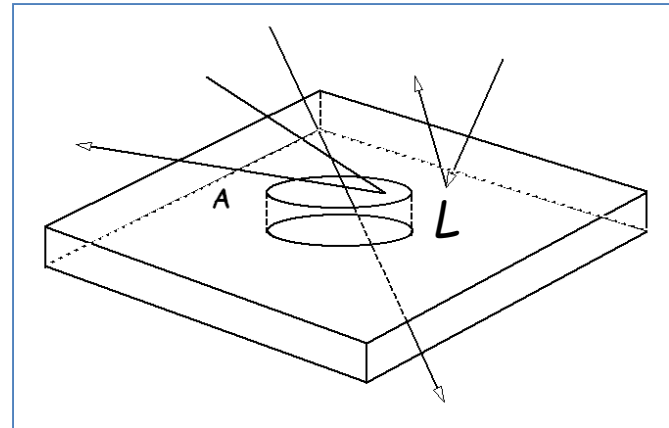

Transmission probability [2]

- Only for few simple cross-sections of the hole, an analytic expression of $k(A,L)$ exists.
- For arbitrary shapes, numerical integration of an integro-differential equation must be carried out, and no analytical solution exists:

7. Clausing's investigation of the transmission probability of a tube

Clausing²⁵⁻³⁴ calculated the probability W for a tube of circular cross-section

$$W = \int_0^L W_{SR}(x) \cdot w(x) dx + W_{SS}(L) \quad (27)$$

where $w(x)$ is given by an integral equation

$$w(x) = \int_0^L W_{RR}(\xi-x) d\xi \cdot w(\xi) + W_{RS}(L-x) \quad (28)$$

down $w(x)$ in the case of a circular tube:

$$w(x) = \frac{1}{4R} \int_0^L \left\{ 2 + \frac{(\xi-x)^3}{[(\xi-x)^2 + 4R^2]^{\frac{3}{2}}} - \frac{3(\xi-x)}{[(\xi-x)^2 + 4R^2]^{\frac{1}{2}}} \right\} w(\xi) d\xi + \frac{1}{4R} \left\{ \frac{1}{[(L-x)^2 + 4R^2]^{\frac{1}{2}}} + \frac{(L-x)^2}{[(L-x)^2 + 4R^2]^{\frac{3}{2}}} - 2(L-x) \right\} \quad (29)$$

(ref. W. Steckelmacher, Vacuum 16 (1966) p561-584)

Where W_{SR} , W_{SS} , W_{RR} and W_{RS} are appropriate functions of R and relate to probabilities of the molecular passage and emittance of molecules (assuming a cosine law of emission) from different parts of the tube wall. Clausing also showed that the function $w(x)$ was related to the impact density $g(x)$ for molecules impinging on the walls of the tube, where x is measured along the tube length. Defining the relative impact density $h(x) = \frac{g(x)}{N_0}$, he proved the identity

$$h(x) \equiv w(L-x) \quad (30)$$

This proof depends on the principle of detailed balancing according to which for each direction and velocity the number of emitted molecules is equal to the number adsorbed (see also Clausing²⁷).

In trying to solve the integral equation Clausing³²⁻³⁴ assumes that for $\frac{R}{L}$ large (≥ 1) a good solution is given by

$$w(x) = \alpha + \frac{1-2\alpha}{L} \cdot x \quad (31)$$

with $\alpha = \text{const}$. Substitution of this in the integral actually gave an expression for α which may be written in the form:

$$\alpha = \frac{[u(u^2+1)^{\frac{1}{2}} - u^2] - [v(v^2+1)^{\frac{1}{2}} - v^2]}{\frac{u(2v^2+1) - v}{(v^2+1)^{\frac{3}{2}}} - \frac{v(2u^2+1) - u}{(u^2+1)^{\frac{3}{2}}}} = \alpha \left(\frac{R}{L} \cdot \frac{x}{L} \right) \quad (32)$$

where $u = (L-x)/2R$ and $v = x/2R$, ie $u = (L/R) - v$ (34)

He then selected α such that $W = \frac{8R}{3L}$ for long tubes, ie assuming the Knudsen formula for long tubes. He showed that a good approximation was obtained for short tubes when $L \leq 4R$ by taking

$$\alpha = \frac{\sqrt{L^2 + 4R^2} - L}{4R^2} \quad (35), \text{ and when } L > 4R, \alpha = \alpha \left(\frac{R}{L} \cdot \frac{x}{L} \right) \quad (35)$$

given by the above formula for $\alpha \left(\frac{R}{L} \cdot \frac{x}{L} \right)$ but with

$$x/L = 2R\sqrt{7}/(3L+2R\sqrt{7}) \text{ ie } u = \frac{L\sqrt{7}}{3L+2R\sqrt{7}} \quad (36)$$

With this choice (he points out, it is one of many), for very small R/L

$$\alpha \rightarrow \frac{4R}{3L} \text{ so that } W \rightarrow \frac{8R}{3L}$$

With these approximations Clausing then calculated W for a range of values of L/R , which he tabulated, and these Clausing probability factors formed the basis for flow calculations in tubes for more than 20 years.

Sum of Conductances

- Keeping in mind the interpretation of the conductance as the reciprocal of a resistance in an electric circuit, we may be tempted to use "summation rules" similar to those used for series and parallel connection of two resistors.
- It turns out that these rules are not so far off, they give meaningful results provided some "correction factors" are introduced

$$C = C_1 + C_2 \quad \text{parallel}$$

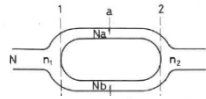

$$\frac{1}{C} = \frac{1}{C_1} + \frac{1}{C_2} \quad \text{series}$$

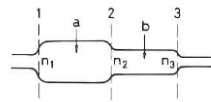

and they can be extended to more elements by adding them up.

- The correction factor takes into account also the fact that the flow of the gas as it enters the tube "develops" a varying angular distribution as it moves along it, even for a constant section.
- At the entrance, the gas crosses the aperture with a "cosine distribution"

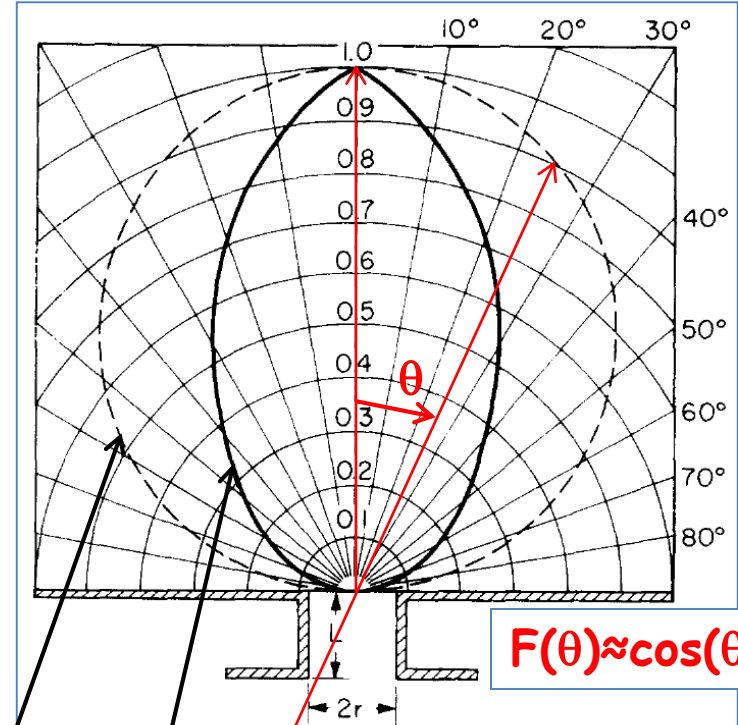

Figure 3. Polar diagram of gas flow issuing from a short cylindrical tube into a vacuum (for the spherical case $L=2r$) compared to flow through an orifice calculated by Clausing (1930).

...while at the exit it has a so called "beamed" distribution, determined by the collisions of the molecules with the side walls of the tube, as shown above (solid/black line)

- As the length of the tube increases...

Molecular Beaming Effect

... so does the beaming, and the forward- and backward-emitted molecules become more and more skewed, as shown here...

W Steckelmacher: The molecular flow conductance for systems of tubes and components and measurement of pumping speed

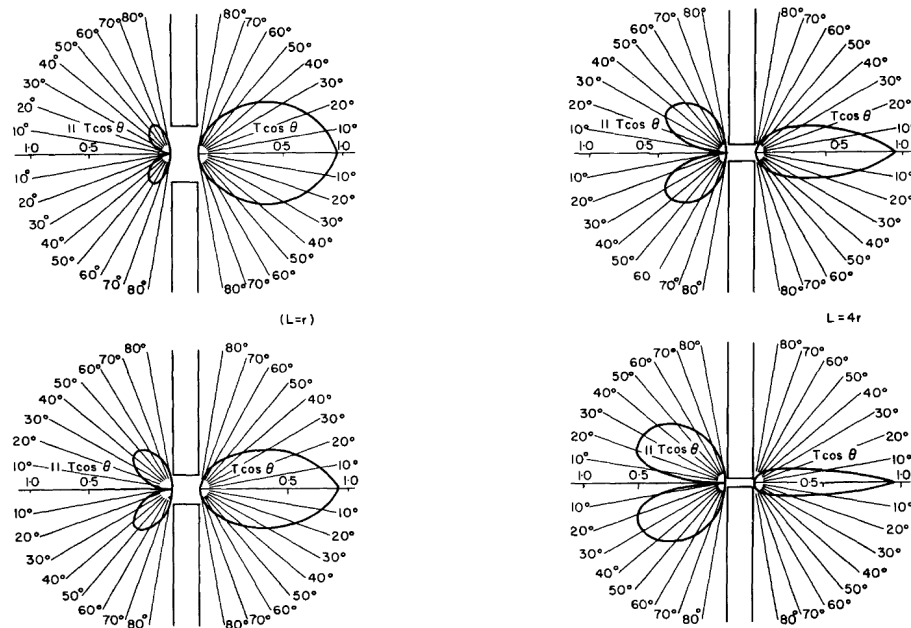

- The transmission probability of any shape can be calculated with arbitrary precision by using the Test-Particle Montecarlo method (TPMC).
- The TPMC generates "random" molecules according to the cosine distribution...

... at the entrance of the tube, and then follows their traces until they reach the exit of the tube.

- Time is not a factor, and residence time on the walls is therefore not an issue (although they can be taken into account).
- Each collision with the walls is followed by a random emission following, again, the cosine distribution...
- ... this is repeated a very large number of times, in order to reduce the statistical scattering and apply the large number theorem.
- The same method can be applied not only to tubes but also to three-dimensional, arbitrarily-shaped components, i.e. "models" of any vacuum system.
- In this case, pumps are simulated by assigning "sticking coefficients" to the surfaces representing their inlet flange.
- The sticking coefficient is nothing else than the probability that a molecule...

Effective Pumping Speed

... hitting that surface gets pumped, i.e. removed from the system.

- The equivalent sticking coefficient s of a pump of pumping speed S [l/s] represented by an opening of A [cm²] is given by

$$s = \frac{S}{A \cdot \frac{v_{mean}}{4}}$$

... i.e. it is the ratio between the given pumping speed and the conductance of the zero-thickness hole having the same surface area of the opening A .

- The “interchangeability” of the concept of conductance and pumping speed, both customarily defined by the units of [l/s] (or [m³/s], or [m³/h]), suggests that if a pump of nominal speed S_{nom} [l/s] is connected to a volume V via a tube of conductance C , the effective pumping speed of the pump will be given by the relationship

$$\frac{1}{S_{eff}} = \frac{1}{S_{nom}} + \frac{1}{C}$$

- From this simple equation it is clear that it doesn't pay to increase the installed pumping speed much more than the conductance C , which therefore sets a limit to the achievable effective pumping speed.

- This has severe implications for accelerators, as they typically have vacuum chambers with a tubular shape: they are “conductance-limited systems”, and as such need a specific strategy to deal with them

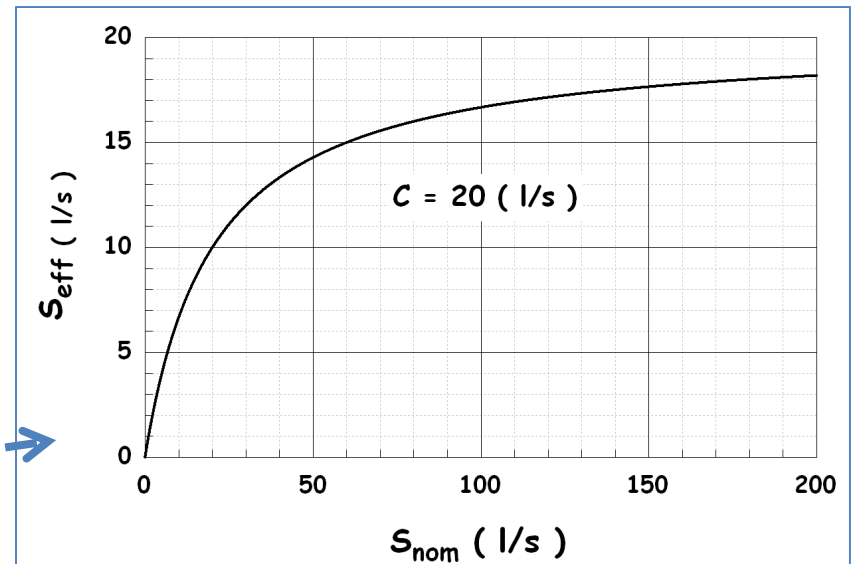

Tutorial on Gas Flow, Conductance, Pressure Profiles Transmission Probability and Analytical Formulae

- The transmission probability of tubes has been calculated many times. This paper (J.Vac.Sci.Technol. 3(3) 1965 p92-95)...

Free Molecular Conductance of a Cylindrical Tube with Wall Sorption

Craig G. Smith and Gerhard Lewin

Plasma Physics Laboratory, Princeton University, Princeton, New Jersey
(Received 26 October 1965)

A Monte Carlo method was used to calculate the probability that a molecule passes through a cylindrical tube with wall sorption. This probability is presented as a function of the ratio of length to radius and the sticking coefficient s of the wall. For $s = 0$, the results confirm those of Clausing for the conductance of a tube of finite length. For $s \neq 0$, wall pumping can greatly reduce the flow of gas, even for very small values of s . The backscattering total flux retained by

Free Molecular Conductance 93

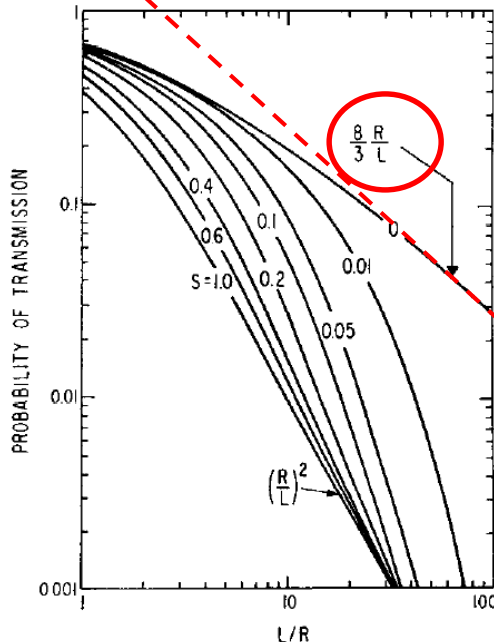

FIGURE 1. Probability that a particle succeeds in passing through a cylindrical tube, as a function of the length to radius ratio and sticking coefficient.

- ... gives us a way to calculate the conductance of a cylindrical tube of any length to radius ratio $L/R > 0.001$:

$$C_{transm}(l/s) = A_{inlet}(cm^2) \cdot 11.77(l/s/cm^2) \cdot P_{transm}$$

- ... where P_{transm} is the transmission probability of the tube, as read on the graph and 11.77 is the "usual" kinetic factor of a mass 28 gas at 20°C.

- Other authors have given approximate equations for the calculation of C_{transm} , namely Dushman (1922), prior to the advent of modern digital computers

$$C_{transm}(l/s) = 12.4 \frac{D^3/L}{1 + 4 \cdot \frac{D}{3 \cdot L}}$$

- ... with D and L in m.

- We can derive this equation by considering a tube as two conductances in series: C_A , the aperture of the tube followed by the tube itself, C_B .

- By using the summation rule for....

Dushman's Formula for Tubes

... 2 conductances in series...

$$\frac{1}{C} = \frac{1}{C_A} + \frac{1}{C_B}$$

... we obtain:

$$C_A = 9.3 \cdot D^3 \quad \text{and} \quad C_B = 12.4 \cdot D^3 / L$$

... with D and L in cm. Substituting above...

$$C = \frac{C_A \cdot C_B}{C_A + C_B} = \frac{12.4 \cdot D^3 / L}{1 + 4 \cdot D / (3 \cdot L)}$$

Beware: the error can be large!

• **Exercise:** 1) estimate the conductance of a tube of D=10 [cm] and L=50 [cm] by using the transmission probability concept and compare it to the one obtained using Dushman's formula.

2) Repeat for a tube with L=500 [cm].

3) Calculate the relative error.

• This fundamental conductance limitation has profound effects on the design of the pumping system of accelerators: the location, number and size of the pumps must be decided on the merit of minimizing the average pressure seen by the beam(s), and reducing local bumps.

• The process is carried out in several steps: first a "back of the envelope" calculation with evenly spaced pumps, followed by a number of iterations where the position of the pumps and eventually their individual size (speed) are customized.

• Step 1 resembles to this: a cross-section common to all magnetic elements is chosen, i.e. one which fits inside all magnets (dipoles, quadrupoles, sextupoles, etc...): this determines a specific conductance for the vacuum chamber c_{spec} (l·m/s), by means of, for instance, the transmission probability method.

Tutorial on Gas Flow, Conductance, Pressure Profiles

Pressure Profiles and Conductance

- We then consider a chamber of uniform cross-section, of specific surface A [cm^2/m], specific outgassing rate of q [$\text{mbar}\cdot\text{l}/\text{s}/\text{cm}^2$], with equal pumps (pumping speed S [l/s] each) evenly spaced at a distance L . The following equations can be written:

$$\begin{cases} Q(x) = -c \frac{dP(x)}{dx} \\ \frac{dQ(x)}{dx} = Aq \end{cases}$$

...which can be combined into

$$c \frac{d^2P}{dx^2} = -Aq$$

... with boundary conditions

$$\begin{cases} \frac{dP}{dx}(x = L/2) = 0 \\ P(x = 0) = AqL/S \end{cases}$$

... to obtain the final result

$$P(x) = \frac{Aq}{2c} (Lx - x^2) + \frac{AqL}{S}$$

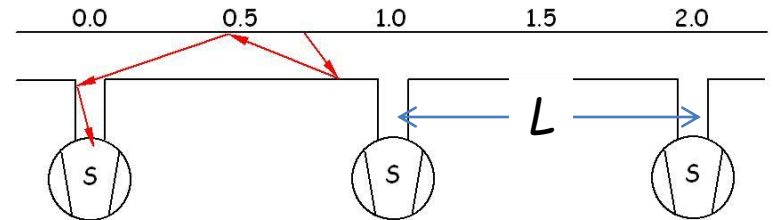

Pressure Profiles and Conductance [2]

- From this equation for the pressure profile, we derive three interesting quantities: the average pressure, the peak pressure, and the effective pumping speed as:

$$P_{AVERAGE} = \frac{1}{L} \int_0^L P(x) dx = AqL \left(\frac{L}{12c} + \frac{1}{S} \right) = AqL (1/S_{EFF})$$

$$P_{MAX} = AqL \left(\frac{1}{8c} + \frac{1}{S} \right); \quad AqL = Q_{tot}; \quad S_{EFF} = \left(\frac{L}{12c} + \frac{1}{S} \right)^{-1}$$

- From the 1st and 3rd ones we see that once the specific conductance is chosen (determined by the size of the magnets, and the optics of the machine), how low the average pressure seen by the beam can be is limited by the effective pumping speed, which in turn depends strongly on c.
- The following graph shows an example of this: for c=20 [l·m/s] and different nominal pumping speeds for the pumps, the graphs show how S_{eff} would change.

- This, in turn, determines the average... pump spacing, and ultimately the number of pumps.

- Summarizing: in one simple step, with a simple model, one can get an estimate of the size of the vacuum chamber, the number and type of pumps, and from this, roughly, a first estimate of the capital costs for the vacuum system of the machine. Not bad! 😊

EFFECTIVE PUMPING SPEED VS PUMP SEPARATION FOR DIFFERENT PUMPING SPEEDS

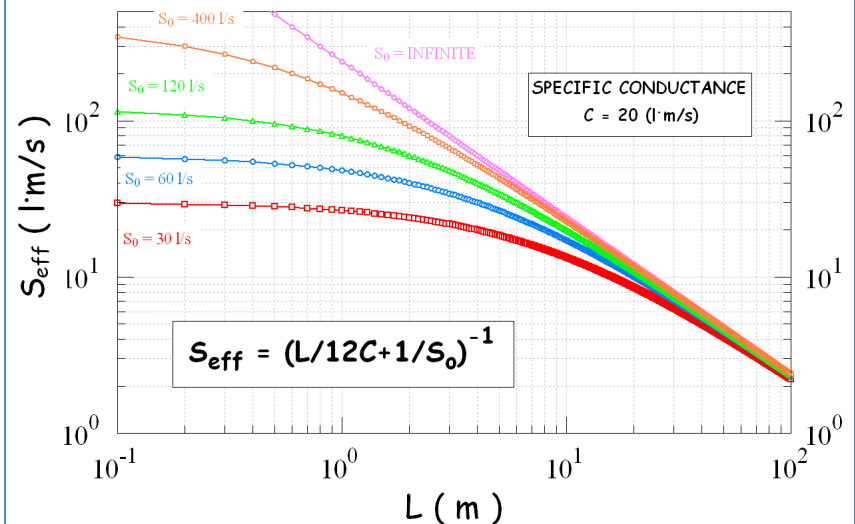

Pressure Profiles and Conductance [3]

- So, the conductance limitation leads to the need to install many smaller pumps rather than a few large ones, as highlighted here below:

(analytical calculation as per \rightarrow)

$$P_{AVERAGE} = \frac{1}{L} \int_0^L P(x) dx = AqL \left(\frac{L}{12c} + \frac{1}{S} \right) = AqL (1/S_{EFF})$$

$$P_{MAX} = AqL \left(\frac{1}{8c} + \frac{1}{S} \right)$$

$$S_{EFF} = \left(\frac{L}{12c} + \frac{1}{S} \right)^{-1}$$

O. Seify, Iranian Light Source, personal comm.

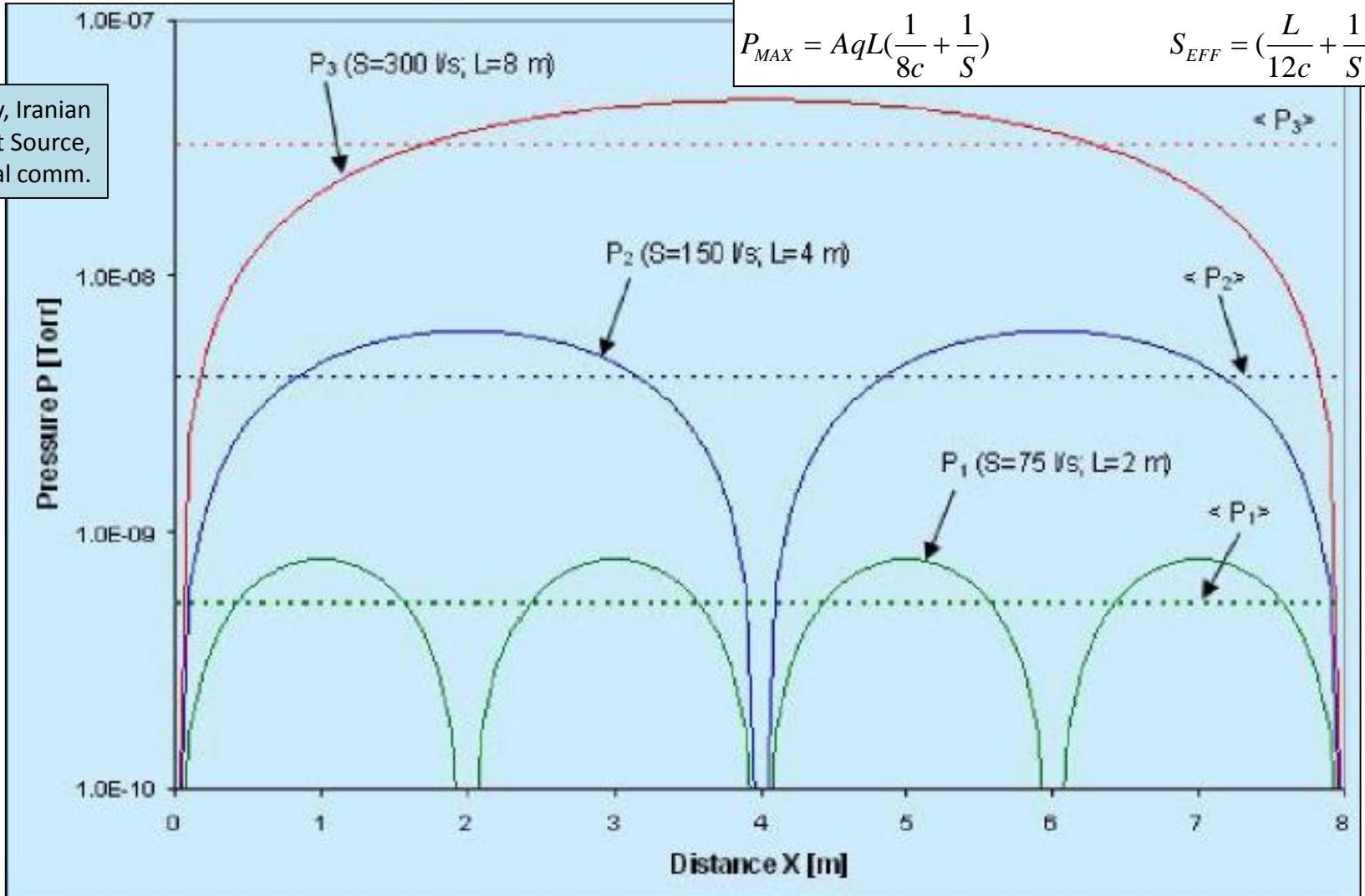

Tutorial on Gas Flow, Conductance, Pressure Profiles

Pressure Profiles and Conductance [3]

- Same as previous one, but calculated via TPMC simulation, Molflow+:
 $Q=1$ mbar·l/s for each of the 3 tubes; $L=8$ m; $S_{inst}=300$ l/s; 1, 2, and 4 pumps;

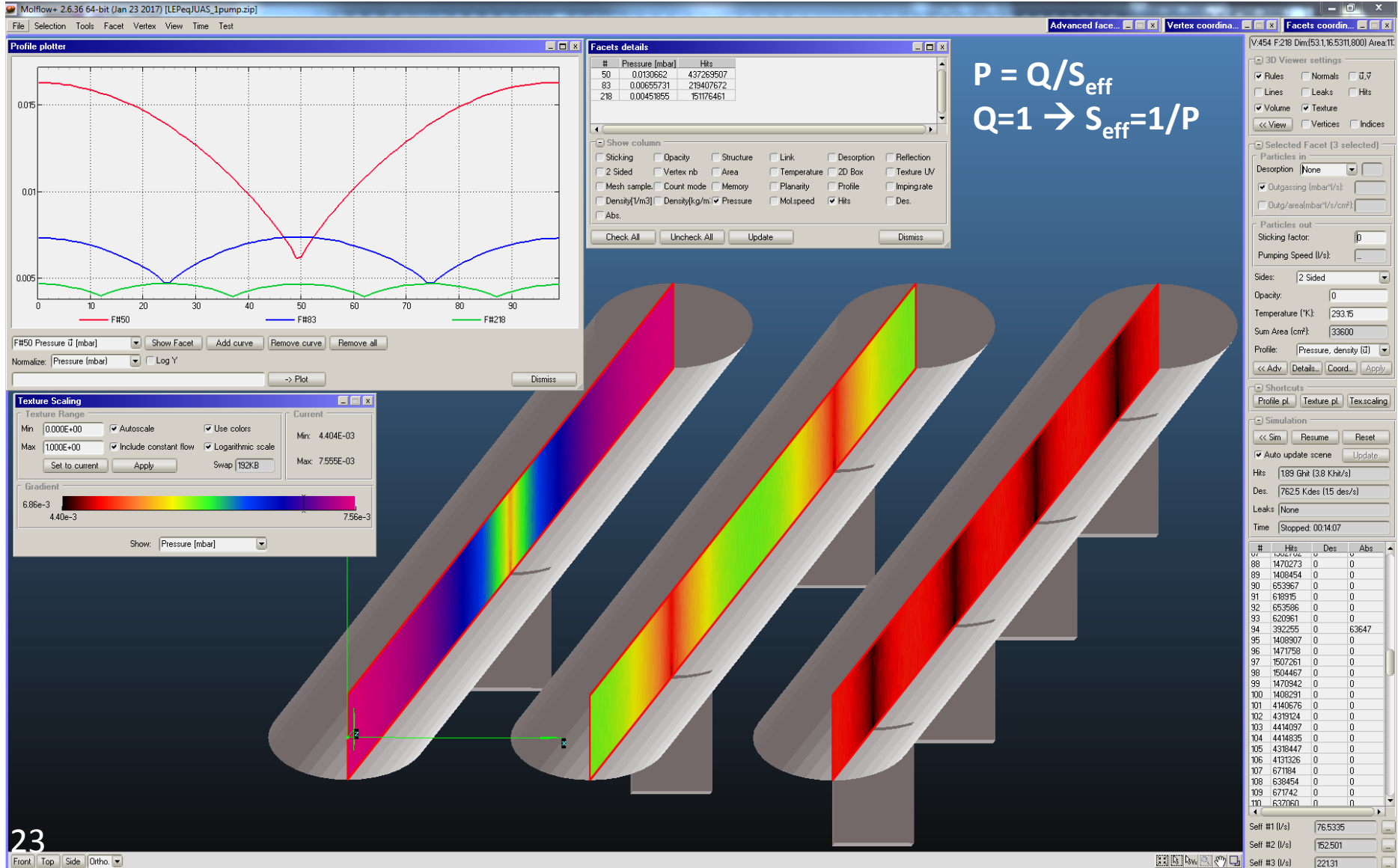

Tutorial on Gas Flow, Conductance, Pressure Profiles

Pressure Profiles and Distributed Pumping

- From the previous analysis it is clear that there may be cases when either because of the size of the machine or the dimensions of (some of its) vacuum chambers, the number of pumps which would be necessary in order to obtain a sufficiently low pressure could be too large, i.e. impose technical and cost issues. One example of this was the LEP accelerator, which was 27 km-long, and would have needed thousands of pumps, based on the analysis we've carried out so far.
- So, what to do in this case? Change many small pumps into one more or less continuous pump, i.e. implement distributed pumping.
- In this case if S_{dist} is the distributed pumping speed, its units are [l/s/m], the equations above become:

$$P_{AVG} = Aq / S_{EFF};$$

$$P_{MAX} = P_{AVG};$$

$$S_{EFF} = S_{dist} \cdot L$$

- We obtain a flat, constant, pressure profile.
- The distributed pressure profile in LEP had been obtained by inserting a NEG-strip along an ante-chamber, running parallel to the beam chamber, and connected by small oval slots:

Fig1 - CROSS-SECTION OF THE DIPOLE VACUUM CHAMBER

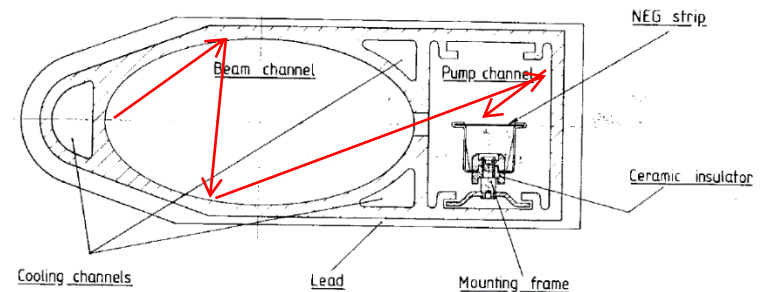

MONTE CARLO SIMULATION OF THE PRESSURE AND OF THE EFFECTIVE PUMPING SPEED

IN THE LARGE ELECTRON POSITRON COLLIDER (LEP)

by

Tingwei Ku*, J-M. Laurent and O. Gröbner

Tutorial on Gas Flow, Conductance, Pressure Profiles

Pressure Profiles and Distributed Pumping [2]

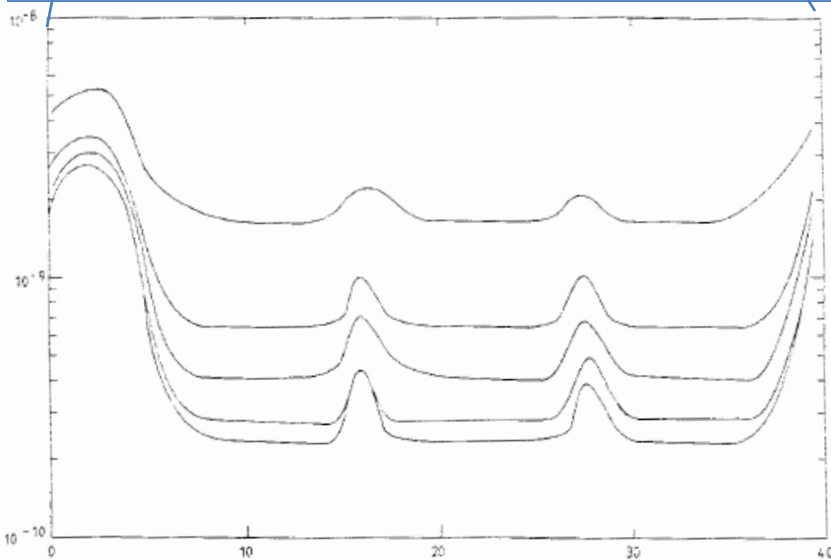
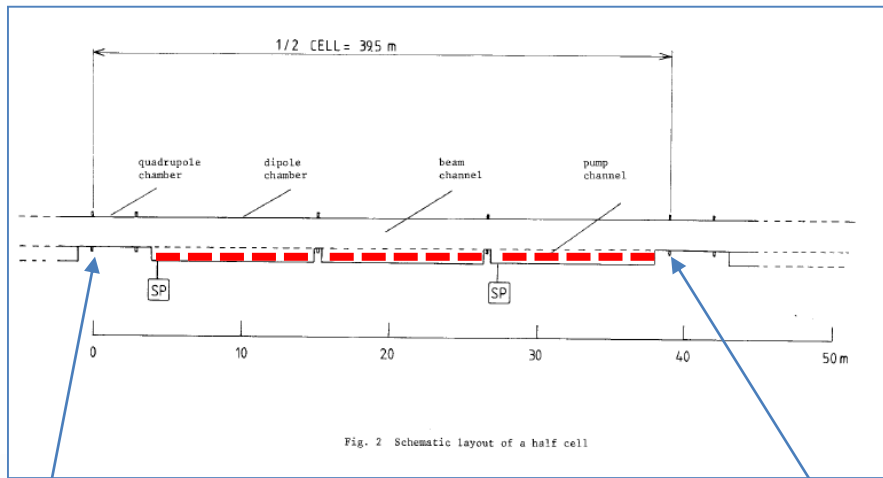

Fig. 5 Pressure profile along a half cell for different pumping probabilities P_G from 0.17 to 0.0085

Effect on pressure profile of S_{dist} : the parabolic pressure bumps are flattened

- **Exercise:** knowing that one metre of NEG-strip and the pumping slots provide approximately 294 [l/s/m] at the beam chamber, derive the equivalent number of lumped pumps of 500 [l/s] which would have been necessary in order to get the same average pressure. (see p.20-21)

Input data:

- $C_{spec}(LEP) = 100$ [l·m/s]
- $S_{dist}(LEP) = 294$ [l/s/m]
- $A_{LEP} = 3,200$ [cm²/m];
- $q = 3.0E-11$ [mbar·l/s/cm²]

- **Exercise:** the SPS transfer line has a vacuum pipe of 60 [mm] diameter, and the distance L between pumps is ~ 60 [m]. The pumping speed of the ion-pumps installed on it is ~ 15 [l/s] at the pipe. Assuming a thermal outgassing rate $q=3E-11$ [mbar·l/s/cm²] calculate:

- 1) P_{max} , P_{min} , P_{avg} , in [mbar]
- 2) S_{eff} , in [l/s]

- A modern way to calculate the **effective pumping speed** of the 20x9 mm² racetrack pumping slots in LEP is via the **Test-Particle Montecarlo method (TPMC)**: $S_{NEG} = 300$ [l/s/m]

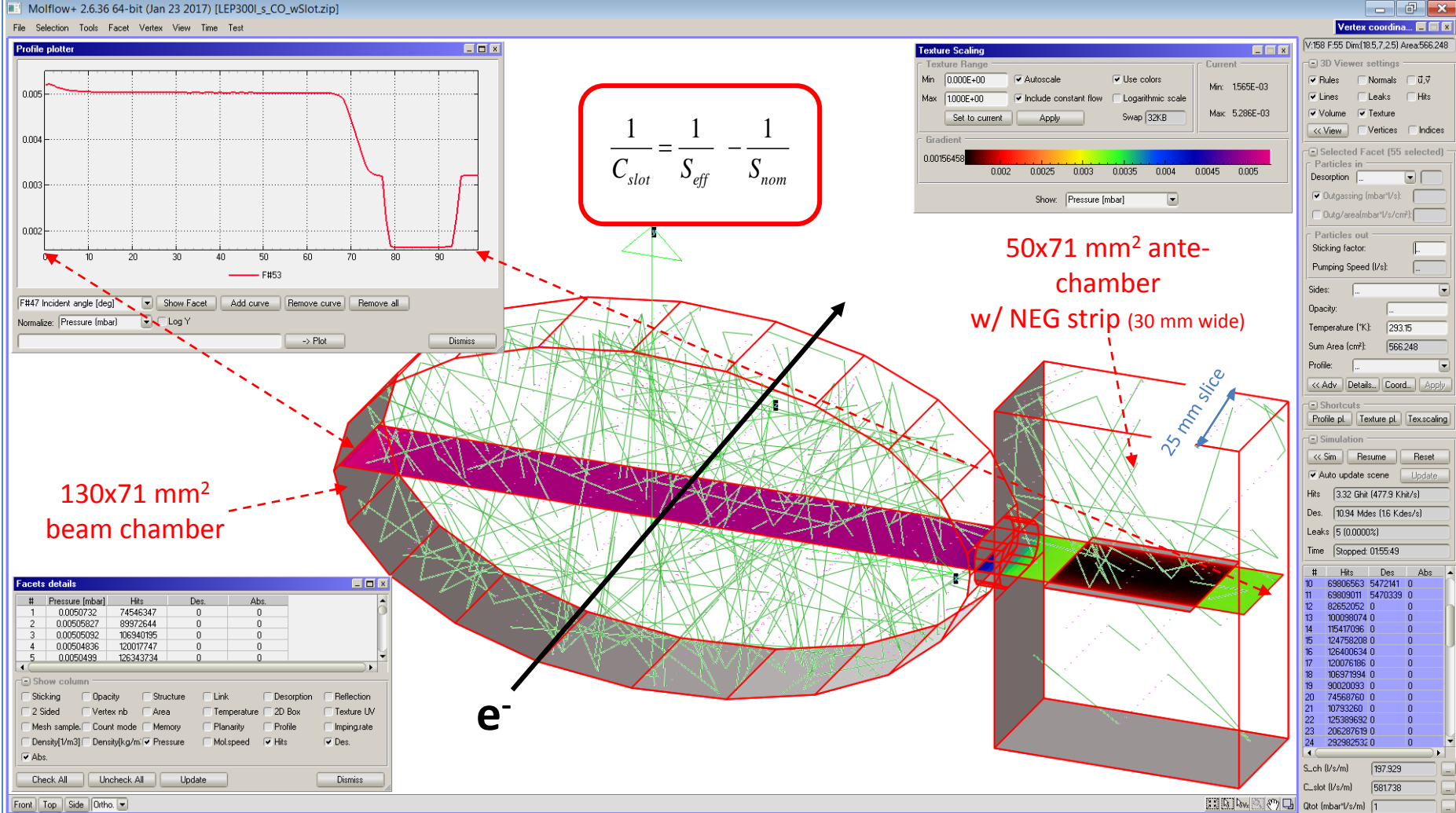

- A virtual "test facet" is laid across the chamber's cross-section and the pressure profile is calculated by recording all the rays crossing it; It is then possible to calculate S_{eff} (l/s/m) and from this C_{slot} [l/s/m] by using the formula shown here above.
- The goal is to maximize C_{slot} and therefore S_{eff} without affecting too much the beam;

- Vacuum chamber geometries of arbitrary complexity can also be designed and analysed via the TPMC method;
- In this case a model can be made with a CAD software, exported in STL format to the TPMC code Molflow+, and then the vacuum properties can be assigned to the different facets, such as outgassing rate, sticking coefficient (equivalent pumping speed), opacity (ratio of void-to-solid, to simulate fine grids, for instance), and more...;
- This example shows the recent analysis of a potential new design of an injection septum magnet for the PS accelerator at CERN (model courtesy of J. Hansen, CERN-TE-VSC);

- At each facet no.i of the model, the local **apparent pumping speed** $S_{app,i}$ can be estimated from the local pressure P_i , via the simple formula:
(Q=total gas load)

$$S_{app,i} = \frac{Q}{P_i}$$

$S_{nom} = 240 \text{ l/s}$
 $S_{app} = 2100 \text{ l/s}$

Pressure gauge

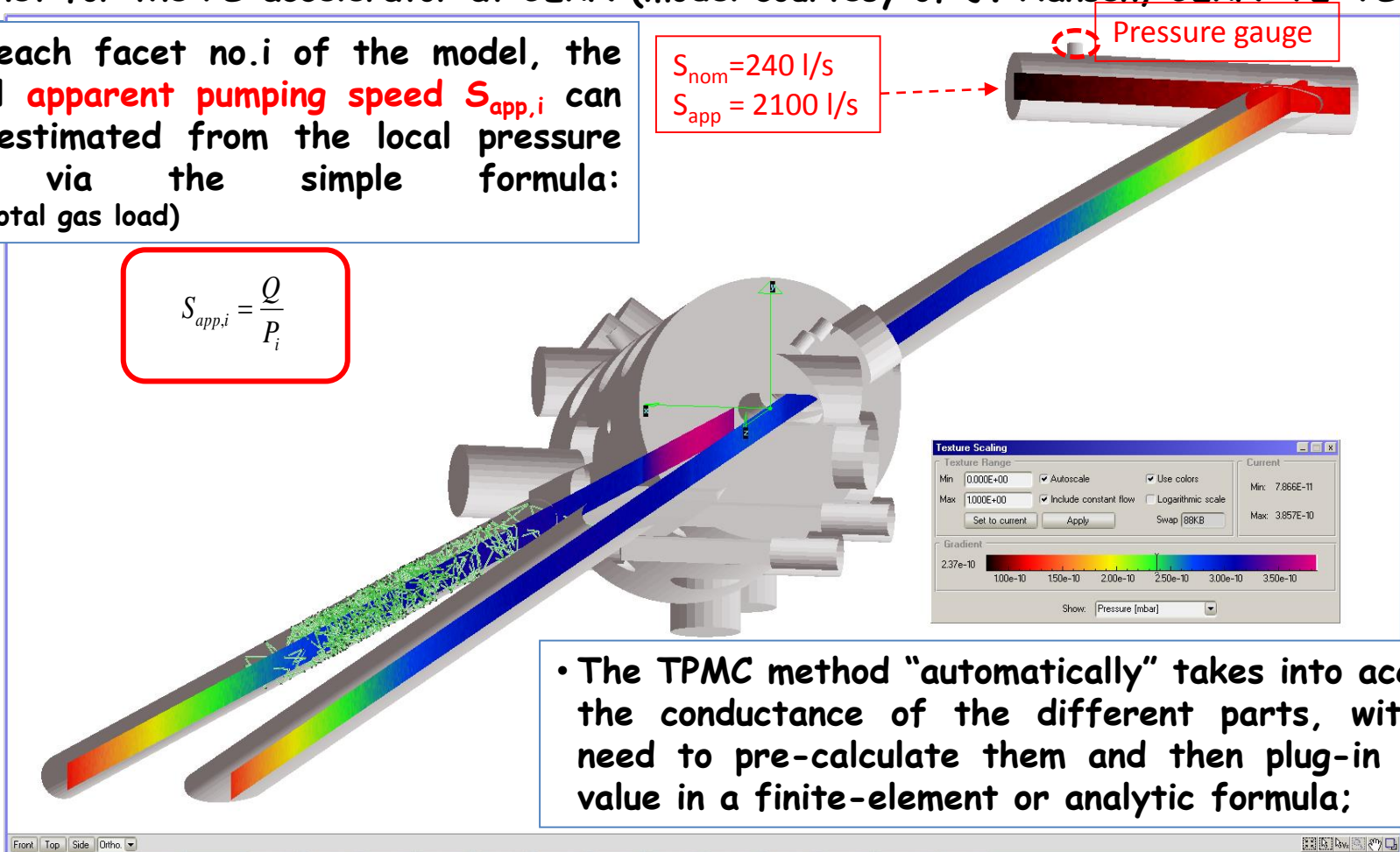

- The TPMC method “automatically” takes into account the conductance of the different parts, with no need to pre-calculate them and then plug-in their value in a finite-element or analytic formula;

One example of a time-dependent Test-Particle Monte Carlo simulation

Propagation of the **pressure wave following an RF breakdown** in a cell of the CLIC linear accelerator:

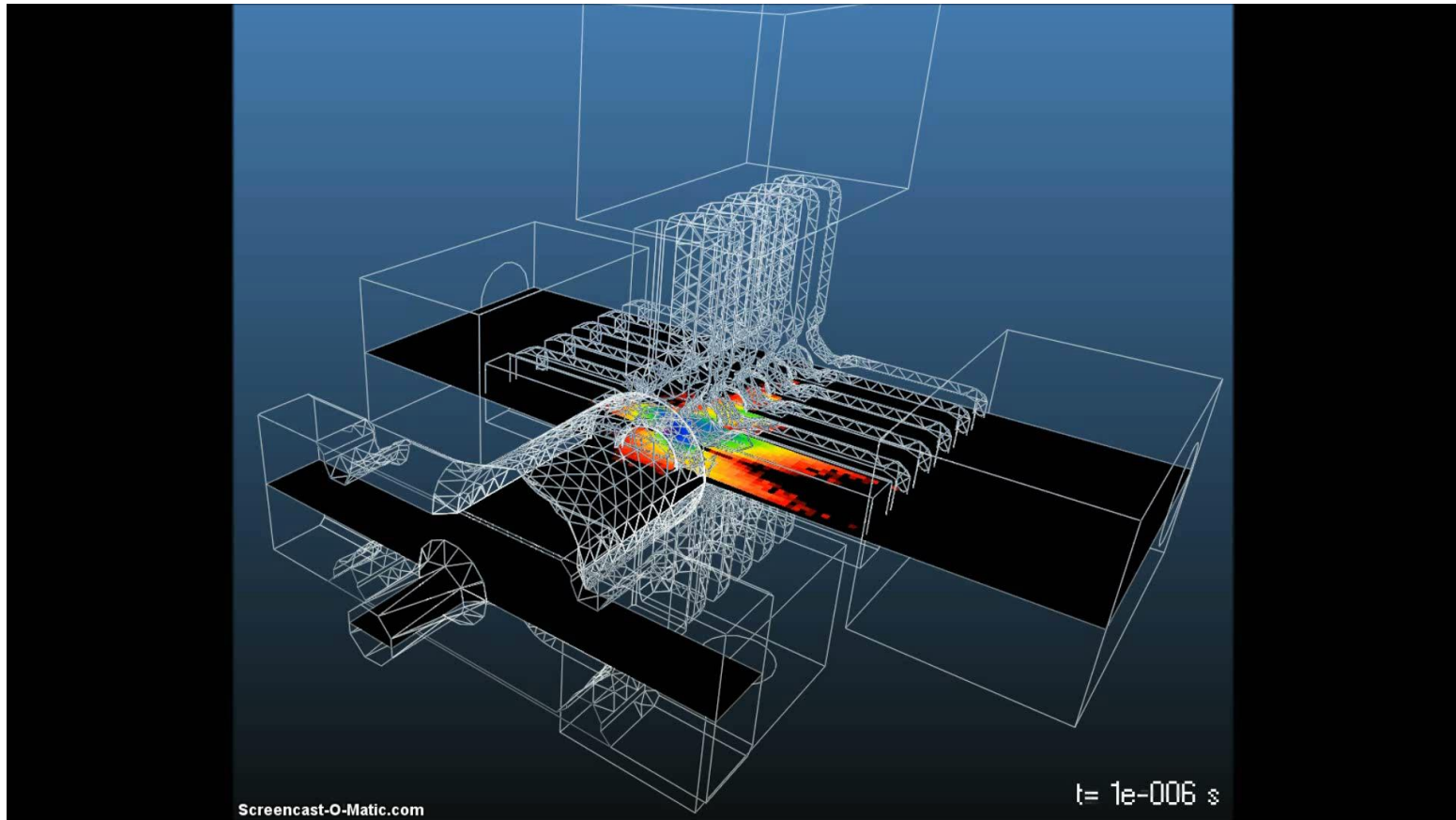

Ref.: M. Ady's PhD thesis CERN-EPFL, 2016;

Summary:

- During this short tutorial we have reviewed some important concepts and equations related to the field of vacuum for particle accelerators.
- We have seen that one limiting factor of accelerators is the fact that they always have long tubular chambers, which are inherently conductance limited.
- We have also seen some basic equations of vacuum, namely the $P=Q/S$ which allows a very first glimpse at the level of pumping speed S which will be necessary to implement on the accelerator in order to get rid of the outgassing Q , with the latter depending qualitatively and quantitatively on the type of accelerator (see V. Baglin's lessons on outgassing and synchrotron radiation, this school).
- Links between the thermodynamic properties of gases and the technical specification of pumps (their pumping speed) as been given: the link is via the equivalent sticking coefficient which can be attributed to the inlet of the pump.
- One simple model of accelerator vacuum system, having uniform desorption, evenly spaced pumps of equal speed has allowed us to derive some preliminary but useful equations relating the *pressure* to the *conductance* to the effective pumping speed, and ultimately giving us a ballpark estimate about the number of pumps which will be needed in our accelerator.
- An example of a real, now dismantled, accelerator has been discussed (LEP), and the advantages of distributed pumping vs lumped pumping detailed.
- Two examples of a more modern way of calculating conductances and pressure profiles (TPMC) have been shown: it should be the preferred method for the serious vacuum scientist;

References

(other than those given on the slides):

- P. Chiggiato, proceedings JUAS 2012-2016
- V. Baglin, proceedings JUAS 2017 and 2018
- M. Ady, PhD thesis CERN-EPFL, 2016, <https://cds.cern.ch/record/2157666?ln=en>
- R. Kersevan, M. Ady: <http://test-molflow.web.cern.ch/>
- CAS - CERN Accelerator School: Vacuum Technology, Snekersten, Denmark, 1999, <https://cds.cern.ch/record/402784?ln=fr>
- R. Kersevan, "Vacuum in Accelerators", Proc. CAS Vacuum, Platja d'Aro, Spain, 2006, <https://cas.web.cern.ch/cas/Spain-2006/Spain-lectures.htm>
- R. Kersevan, "Computation for Vacuum System of Accelerators", Proc. CAS Vacuum 2017, Glumslöv, Sweden, <https://indico.cern.ch/event/565314/>
- M. Ady et al., "Propagation of Radioactive Contaminants Along the Isolde Beamline", Proc. IPAC 2015, Richmond, USA, 2015 <https://cds.cern.ch/record/2141875/files/wepha009.pdf>
- Y. Li et al.: "Vacuum Science and Technology for Accelerator Vacuum Systems", U.S. Particle Accelerator School, Course Materials - Old Dominion University - January 2015; <http://uspas.fnal.gov/materials/15ODU/ODU-Vacuum.shtml>

Thank you for your attention 😊