

# Building large particle accelerators

## Experience from the LHC project

Philippe Lebrun  
Director, Joint Universities Accelerator School

JUAS 2017 Course 2  
28 February 2018

# Development of circular accelerators

## Performance increases faster than diameter!

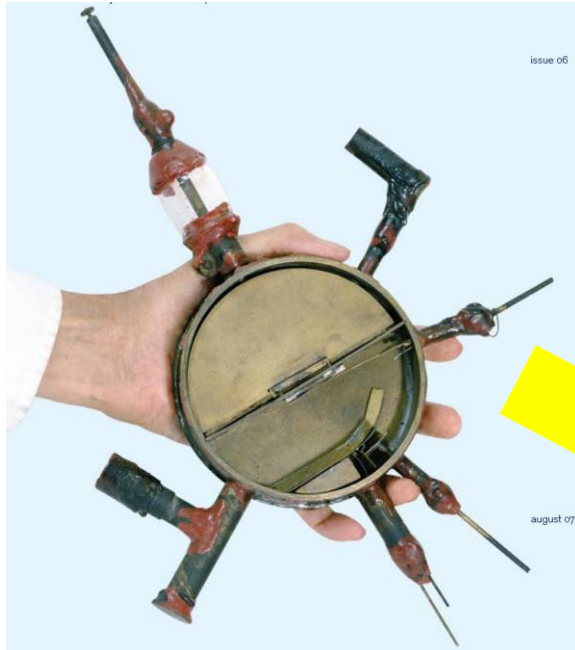

The first cyclotron (1930)

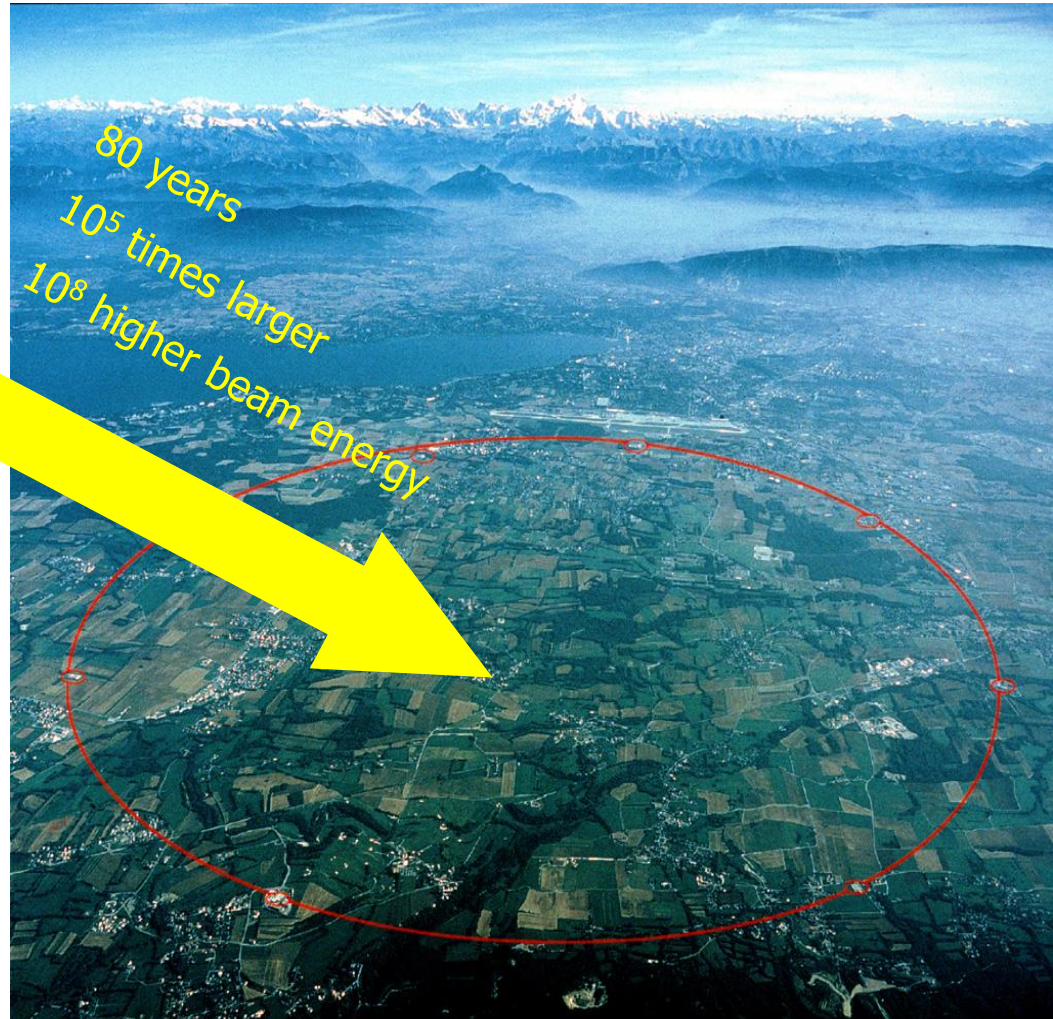

Large Hadron Collider (2009)

## Axes of development of hadron colliders

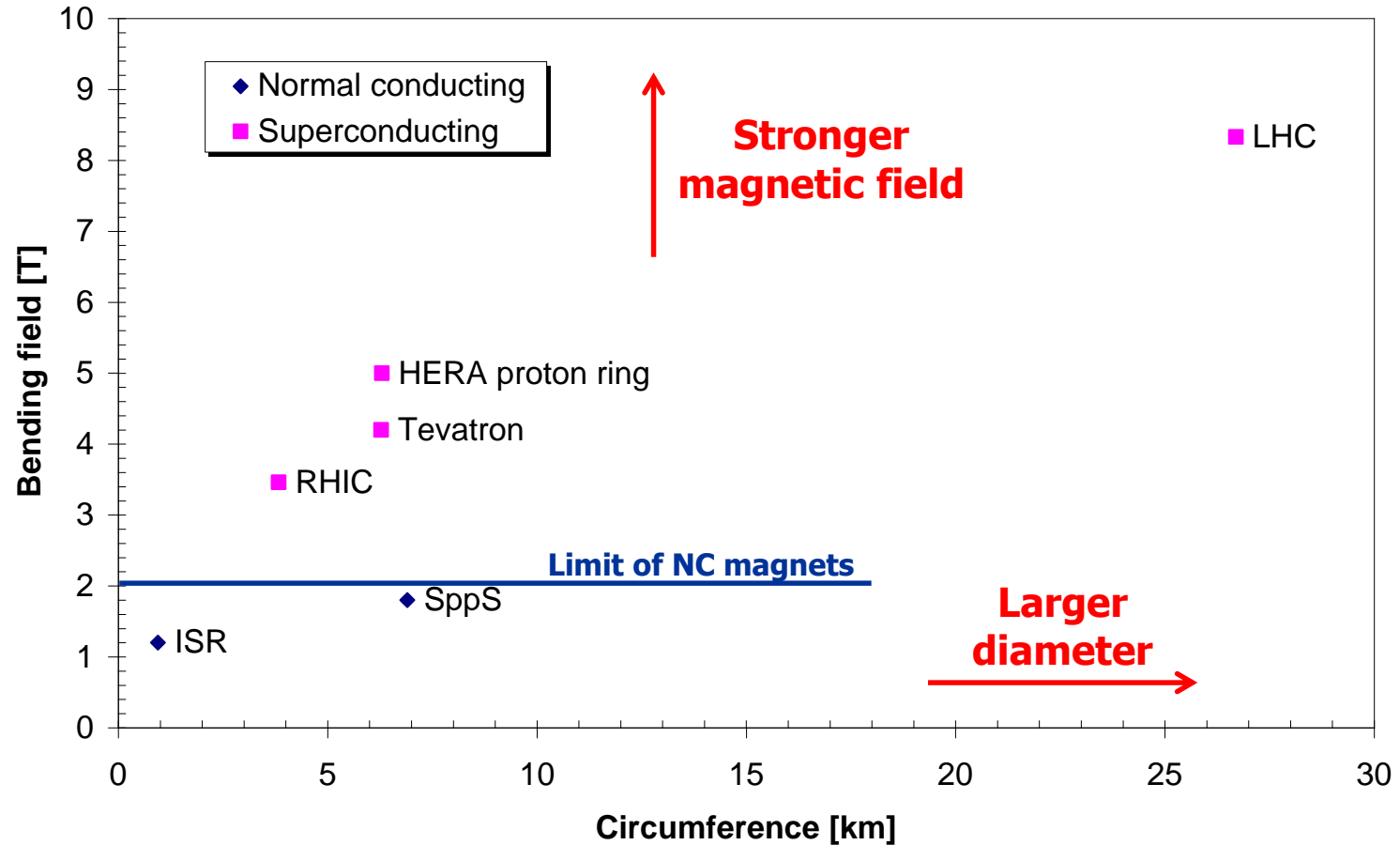

# The LHC project

## Aiming for a new territory in energy and luminosity

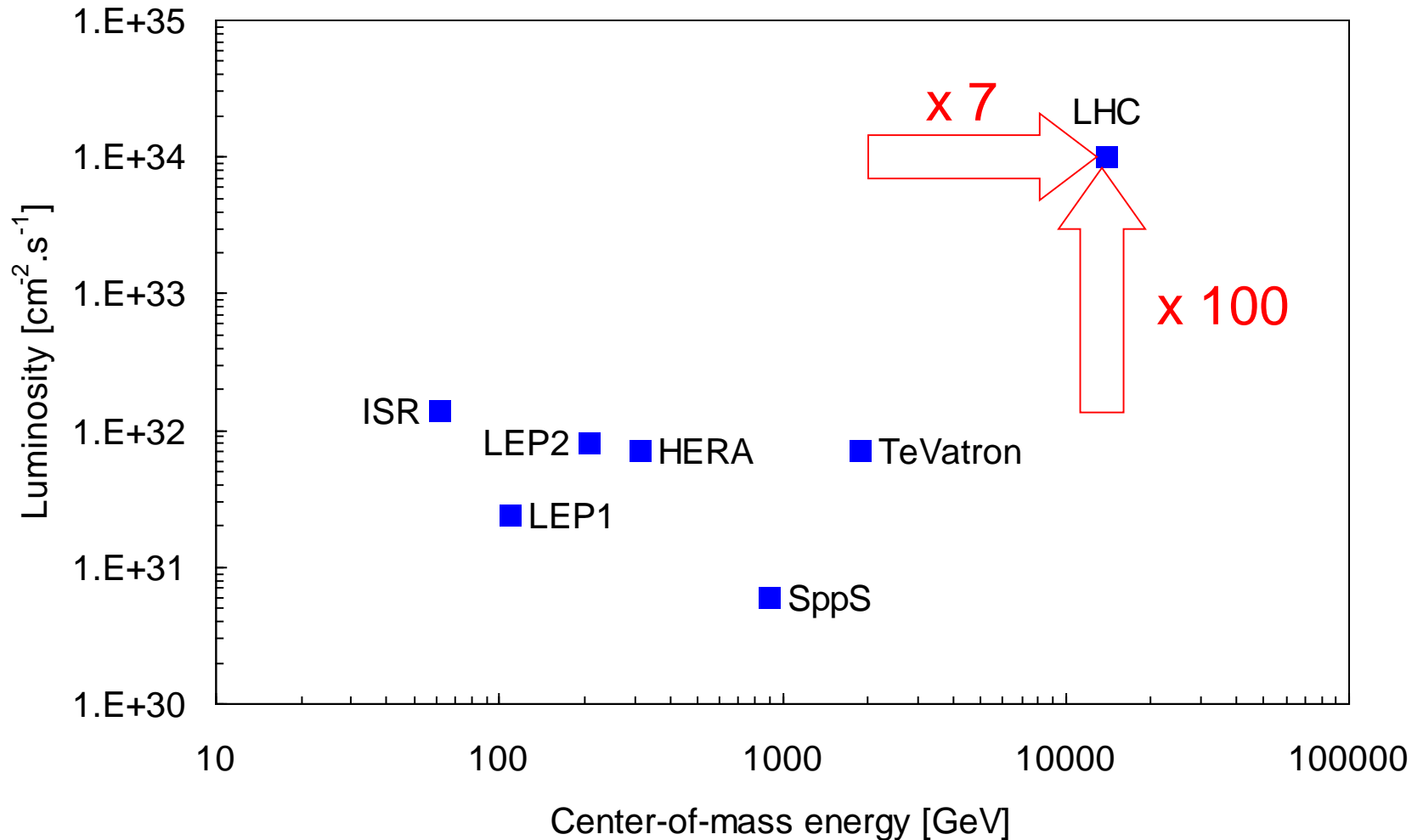

# The LHC project: basic decisions

## ECFA Workshop Lausanne 1984

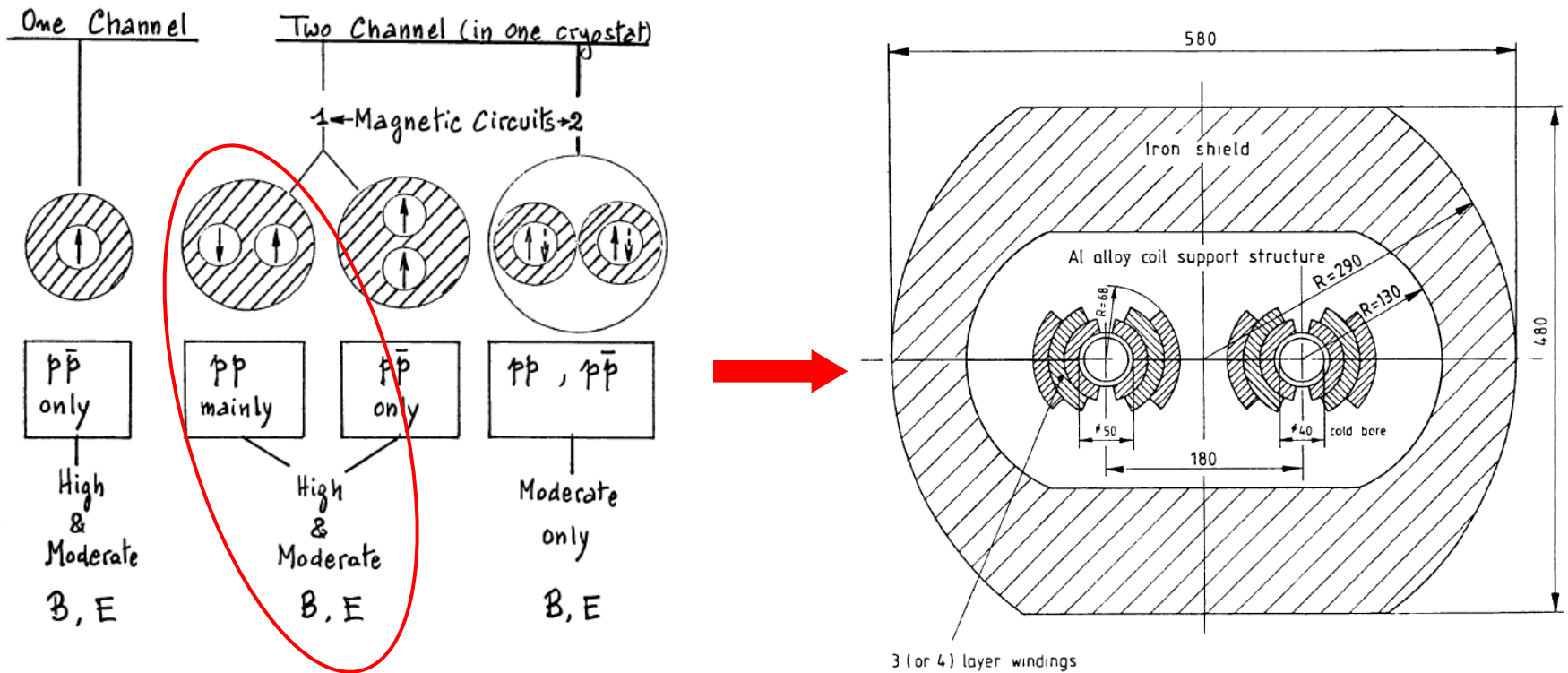

# Technical progress + economy of scale = cost efficiency

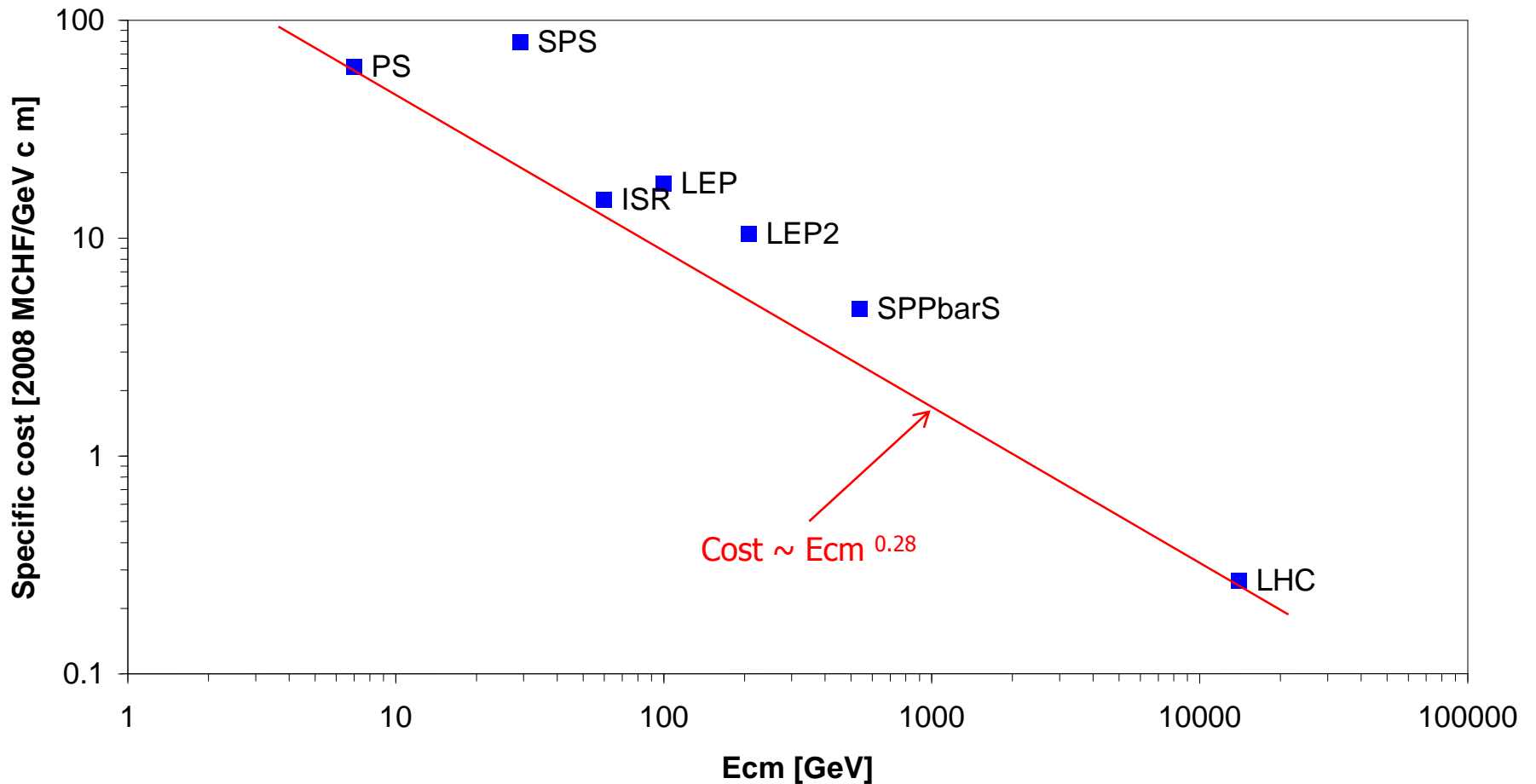

## Cost structure of large accelerator projects

LHC in existing tunnel

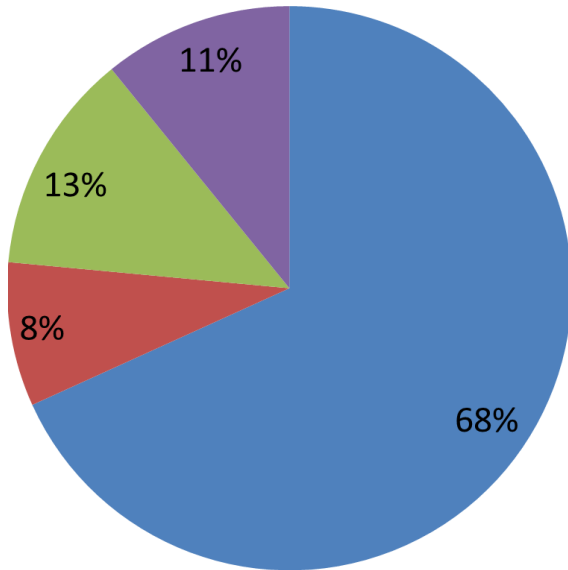

LHC "green field"

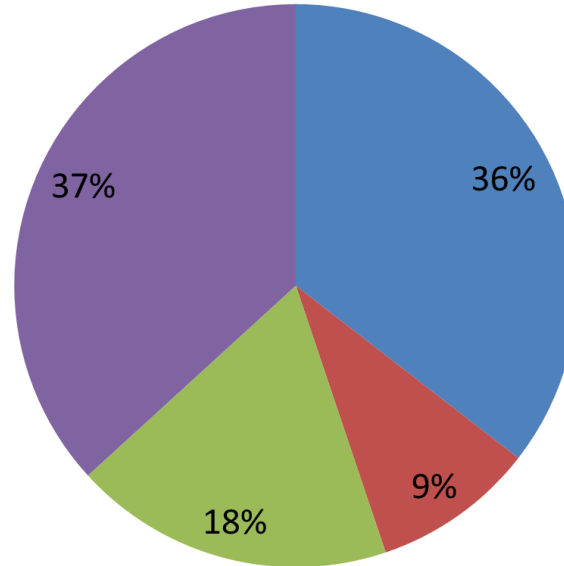

CLIC 500 ≡ "green field"

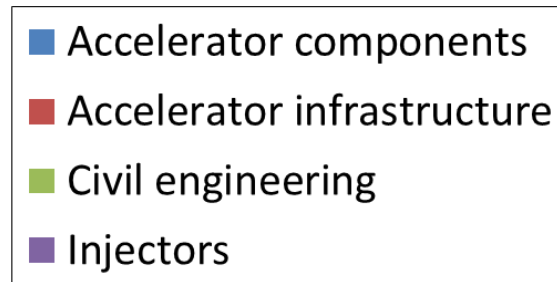
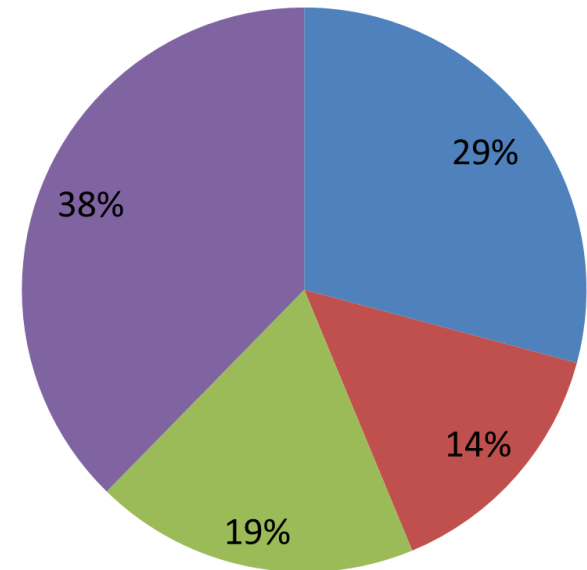

## Technological choices and industrial strategy

- The right level of technology
  - Adaptation & improvement of state-of-the-art for affordability
  - Reasoned & focussed development of emerging technologies
- Doing it in the lab or going to industry?
  - Principle: *go to industry whenever possible*
  - Cases for not going to industry
    - Unability to specify
    - Difficulty to define and manage interfaces
    - No industrial competency available
    - Absence of interest for a one-of production
- Series numbers, variants and production techniques
  - Even « large » accelerator projects are relatively « small » industrial ventures
  - Case for automation seldomly justified
  - Learning curves effectively applicable
- Making best use of prototypes
  - Building know-how and validate developments
  - Non-exclusive partnerships with industry to preserve future competition
  - Sustain interest from companies until main contracts are placed



# The main technical challenge of LHC: magnetic field

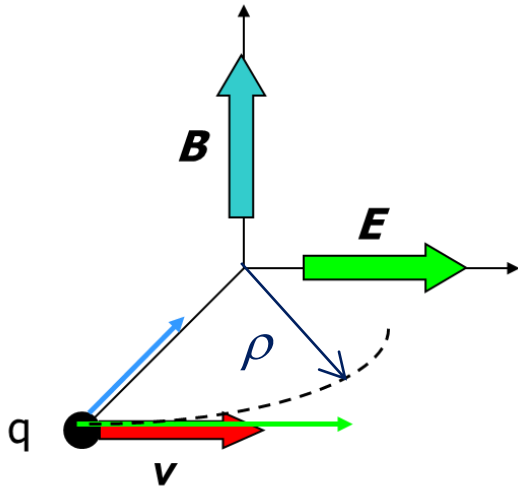

Lorentz force

$$\vec{F} = \frac{d\vec{p}}{dt} = e(\vec{E} + \vec{v} \times \vec{B})$$

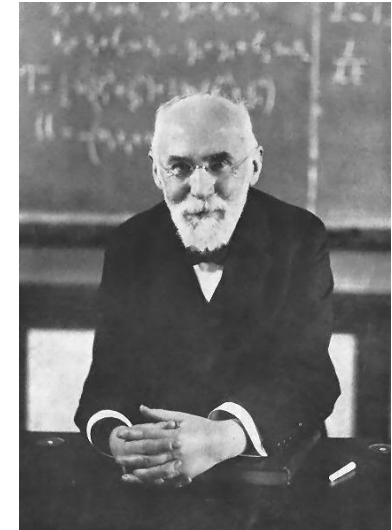

H.A. Lorentz

- In plane normal to  $\vec{B}$

$$F = evB = \frac{mv^2}{\rho} = \frac{\gamma m_0 v^2}{\rho}$$

- Hence

$$\frac{p}{e} = B\rho$$

**magnetic rigidity**

$$B\rho[\text{T}\cdot\text{m}] \approx \frac{p[\text{GeV}/c]}{0.3}$$

- Nominal momentum 7000 GeV/c
- Bending radius 2804 m
- Nominal field  $\approx 7000 / (0.3 \times 2804) \approx 8.3 \text{ T} \Rightarrow$  **superconducting magnets**

## Basics of superconductivity

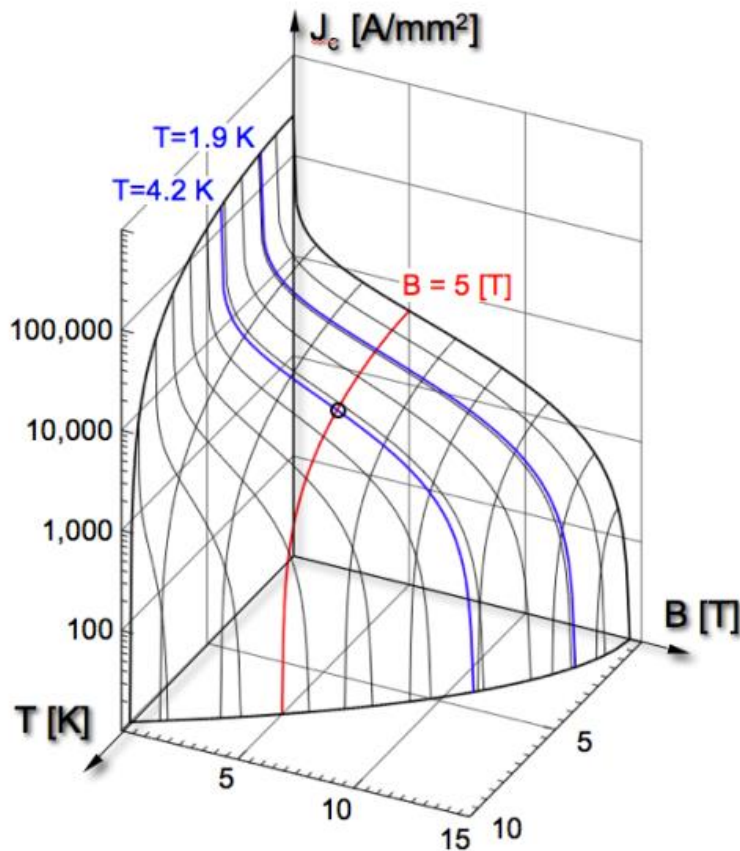

- The superconducting state only occurs in a limited domain of (low) temperature, magnetic field and current density, limited by the «critical surface» of the material
- The working point must remain below the «critical surface» of the superconductor
- Operating at lower temperature increases the working range in the magnet design plane ( $J_c/B$ )
- In practice, operate at temperature well below  $T_c$
- Most of superconducting magnets in use today use Nb-Ti with  $T_c = 9.2$  K

# The right level of (superconducting) technology

## Why use Nb-Ti at 2 K instead of Nb<sub>3</sub>Sn at 4.2 K?

## Why not use high-temperature superconductors?

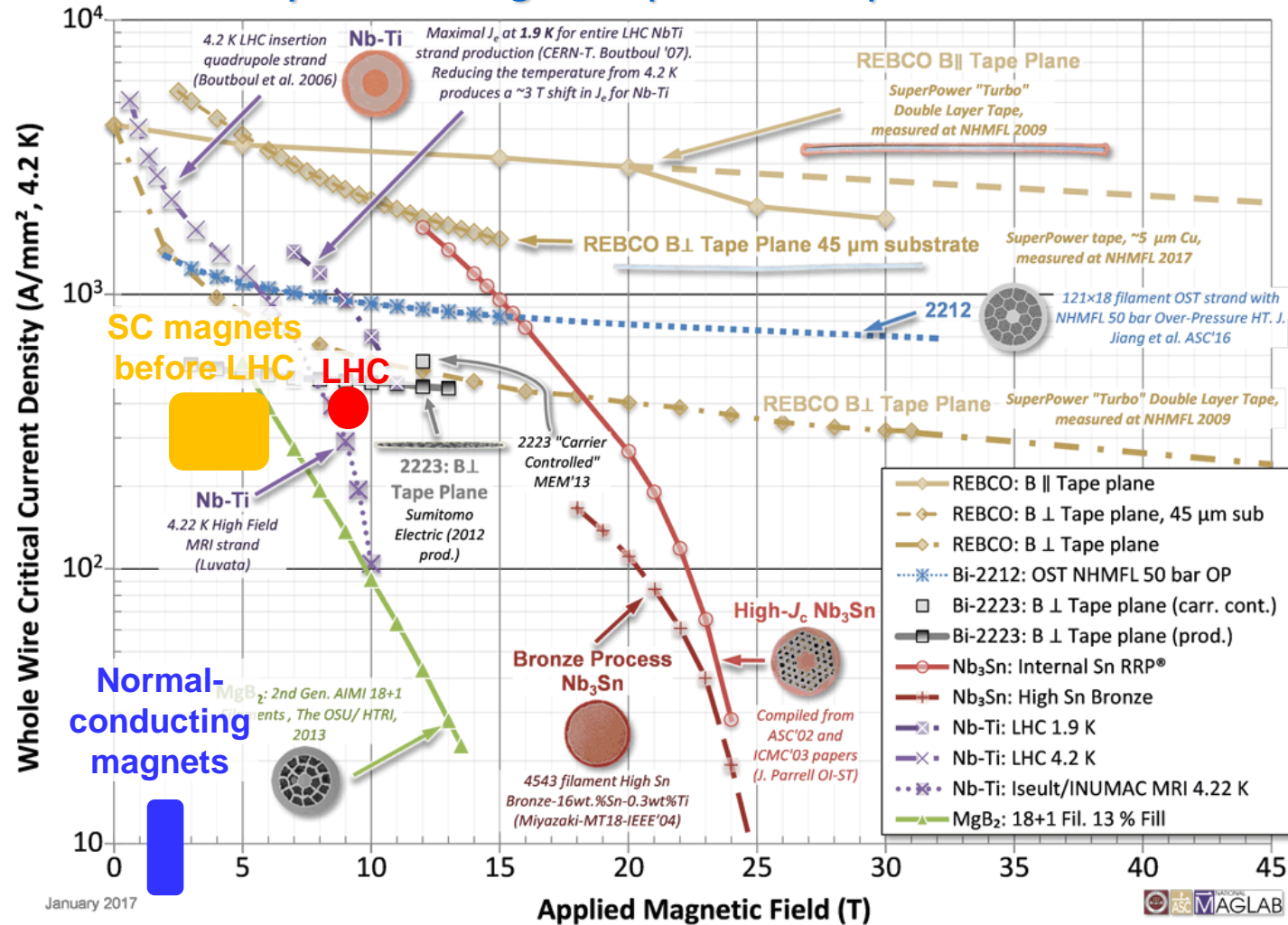

# Progress: incremental vs breakthrough

## The case of human genome sequencing

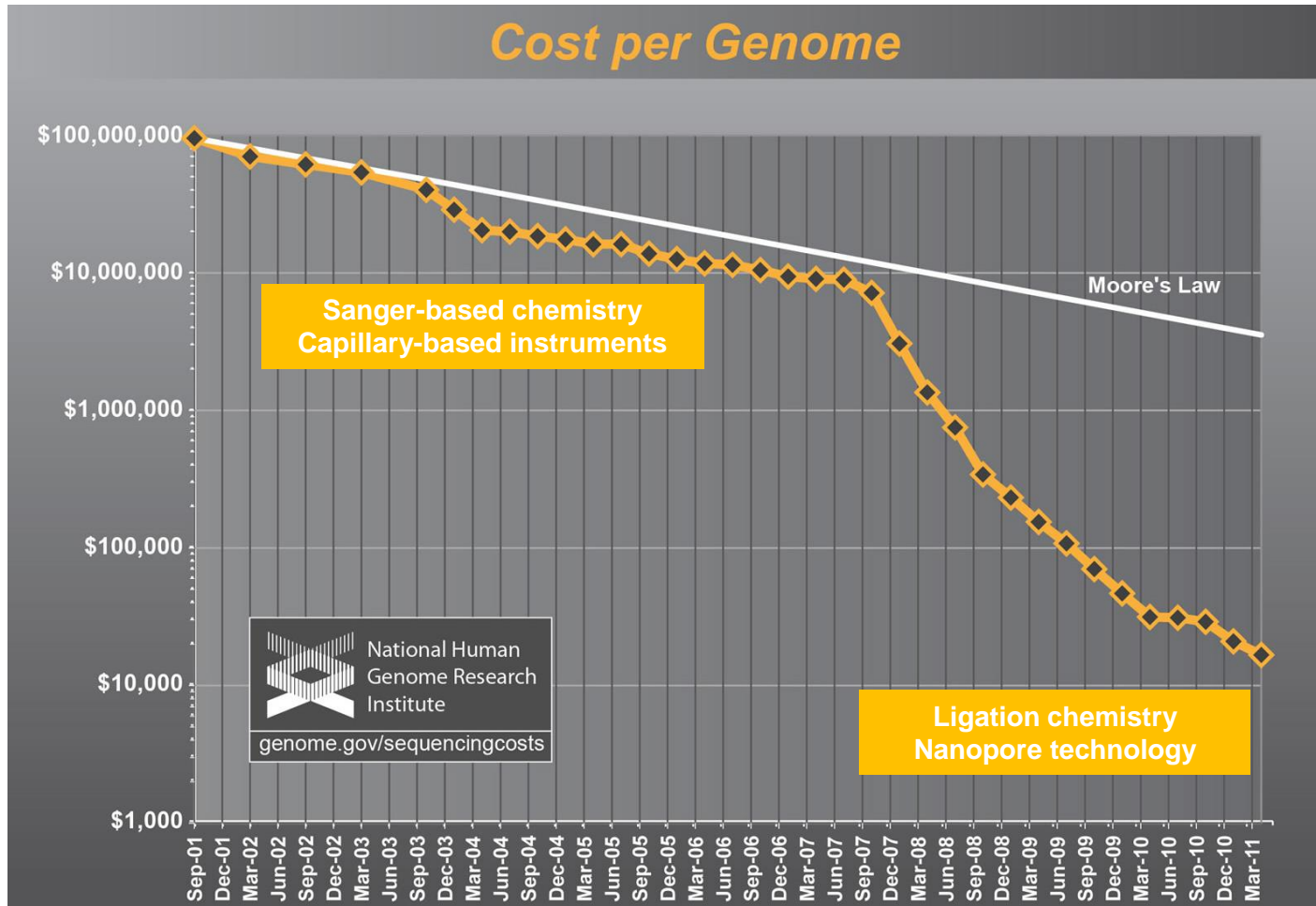

# Understanding discontinuities in cost structure High-field superconducting magnets

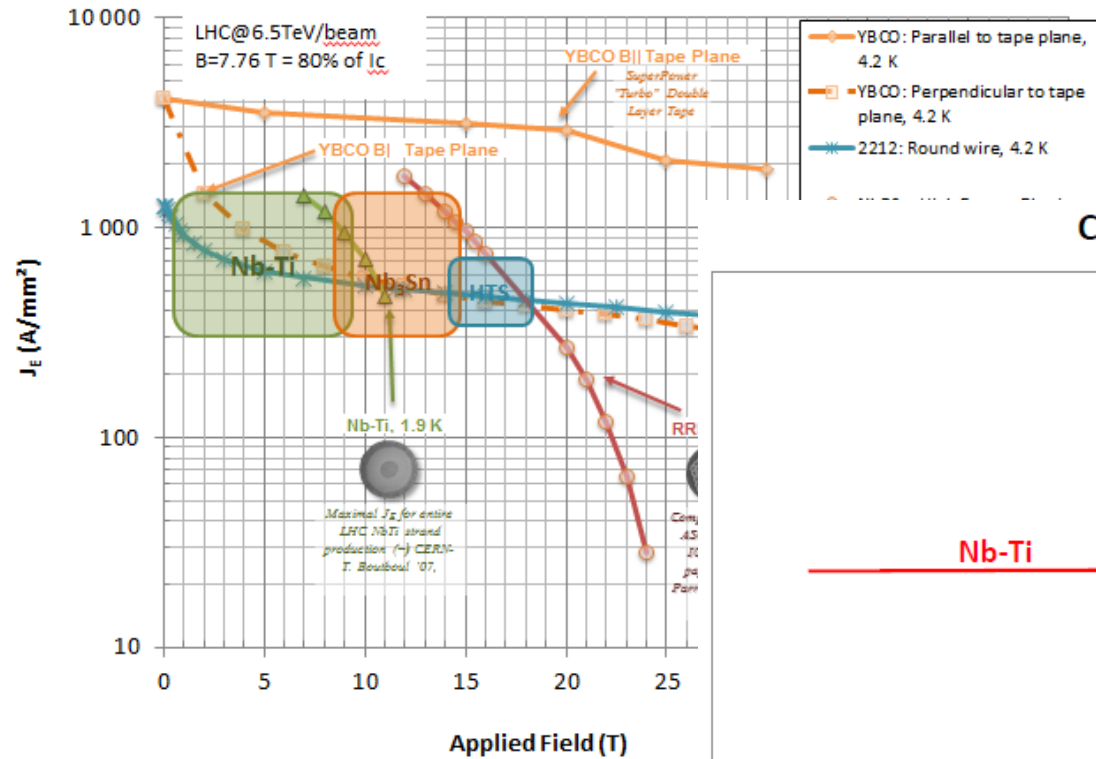

Cost of high-field magnets

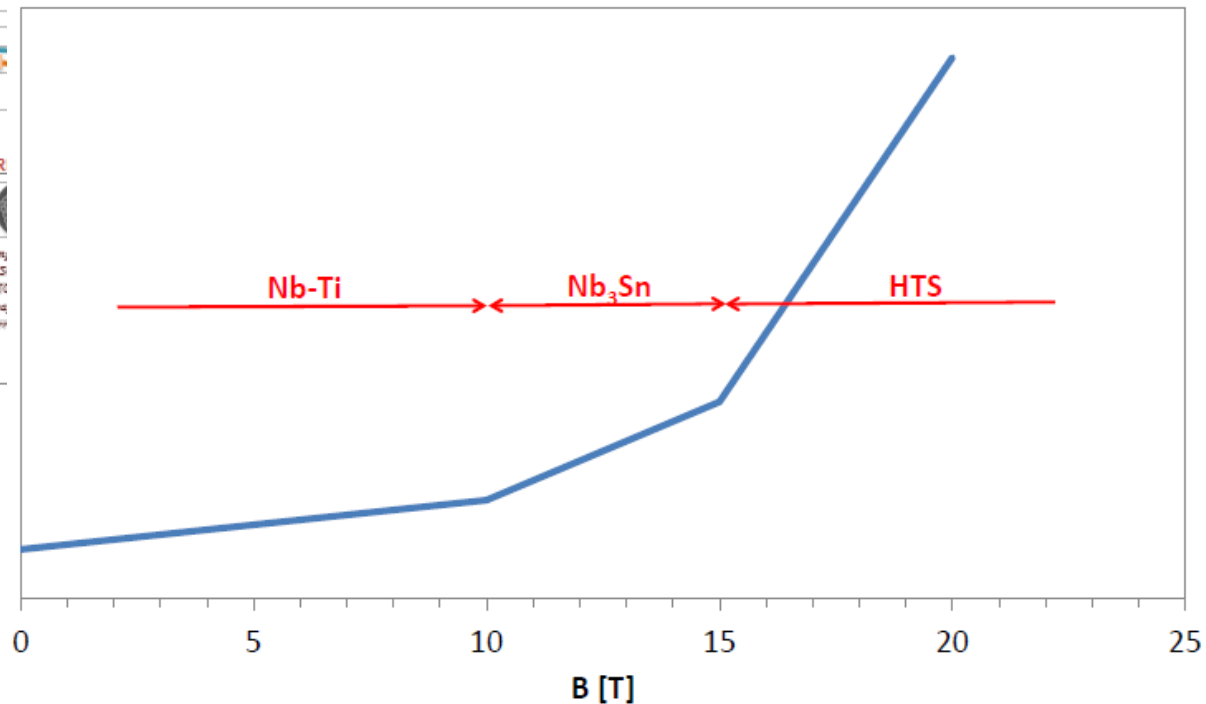

# LHC dipole magnet design... & construction

## How to produce 20 km of this structure

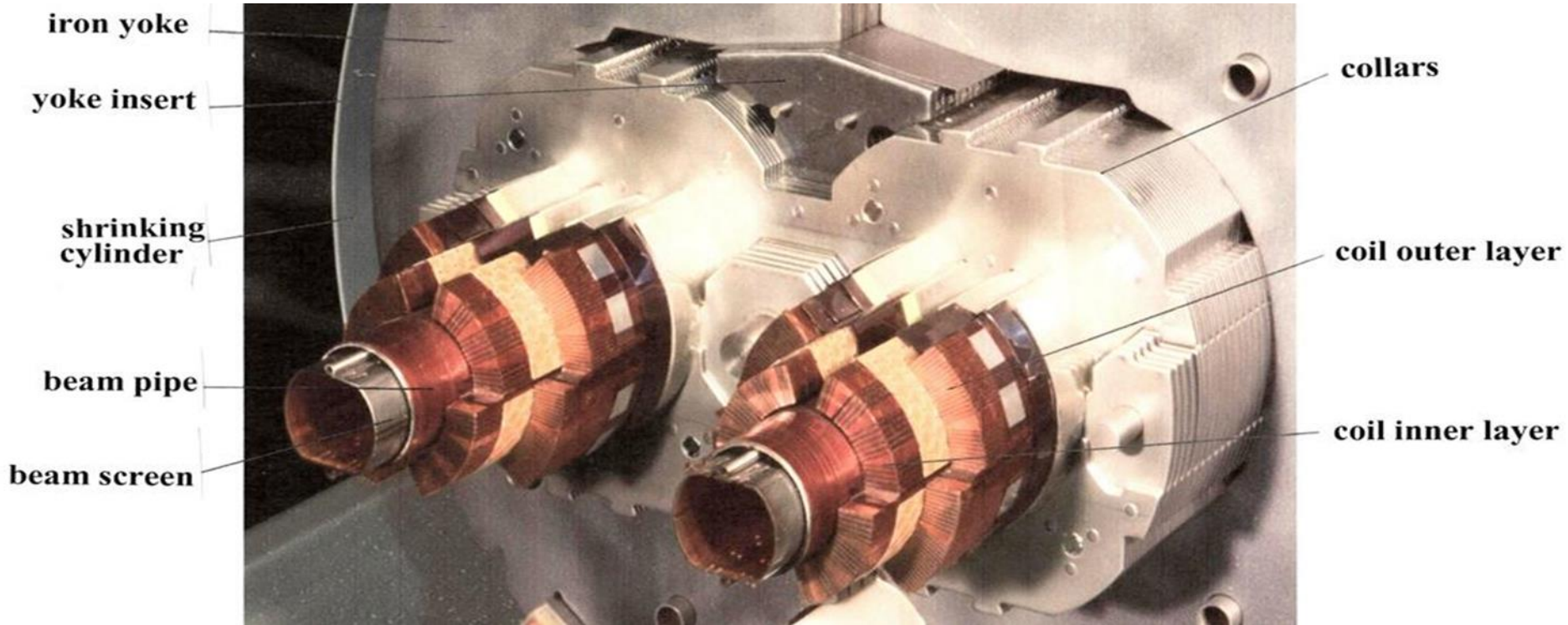

# Load lines of LHC main dipole

## Final optimization: current "grading"

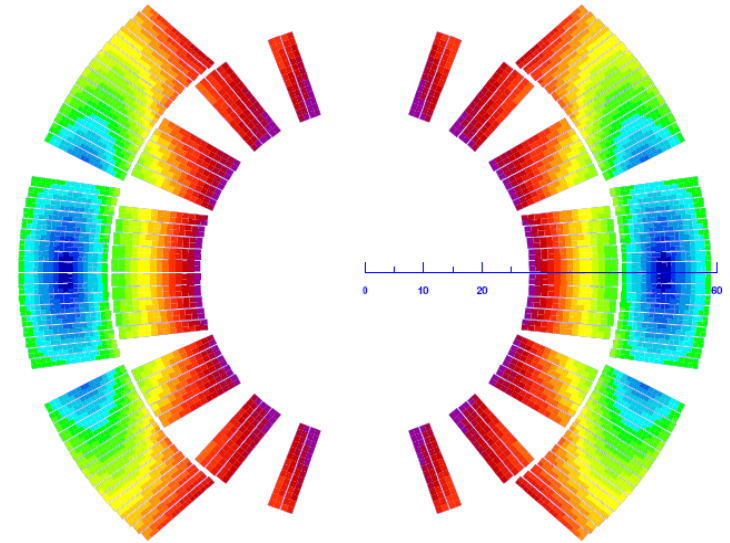
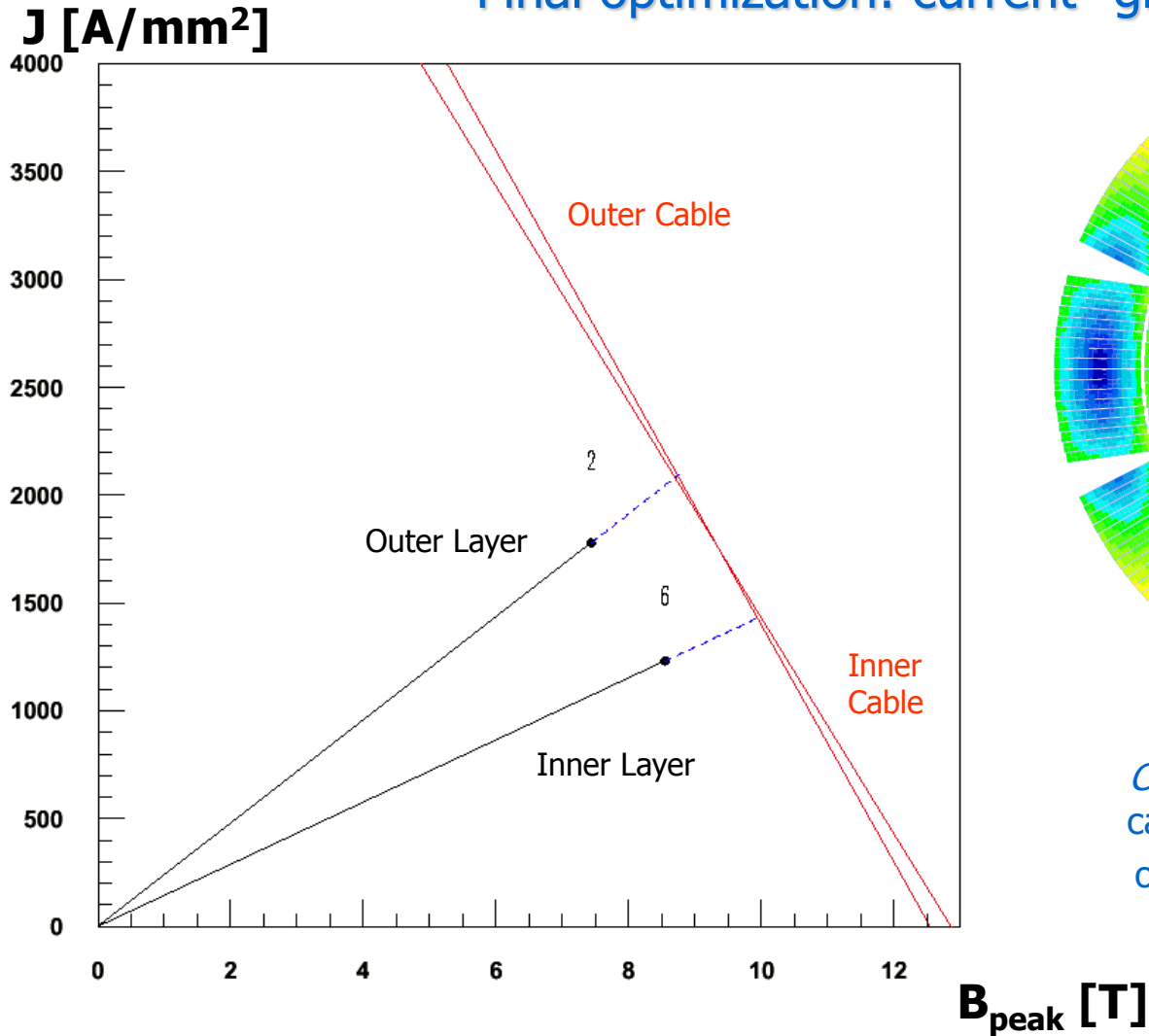

*Current grading* permits the outer cable, which sees a lower field, to operate at higher current density

## 1232 twin-aperture superconducting dipoles 23 km of superfluid helium cryostats

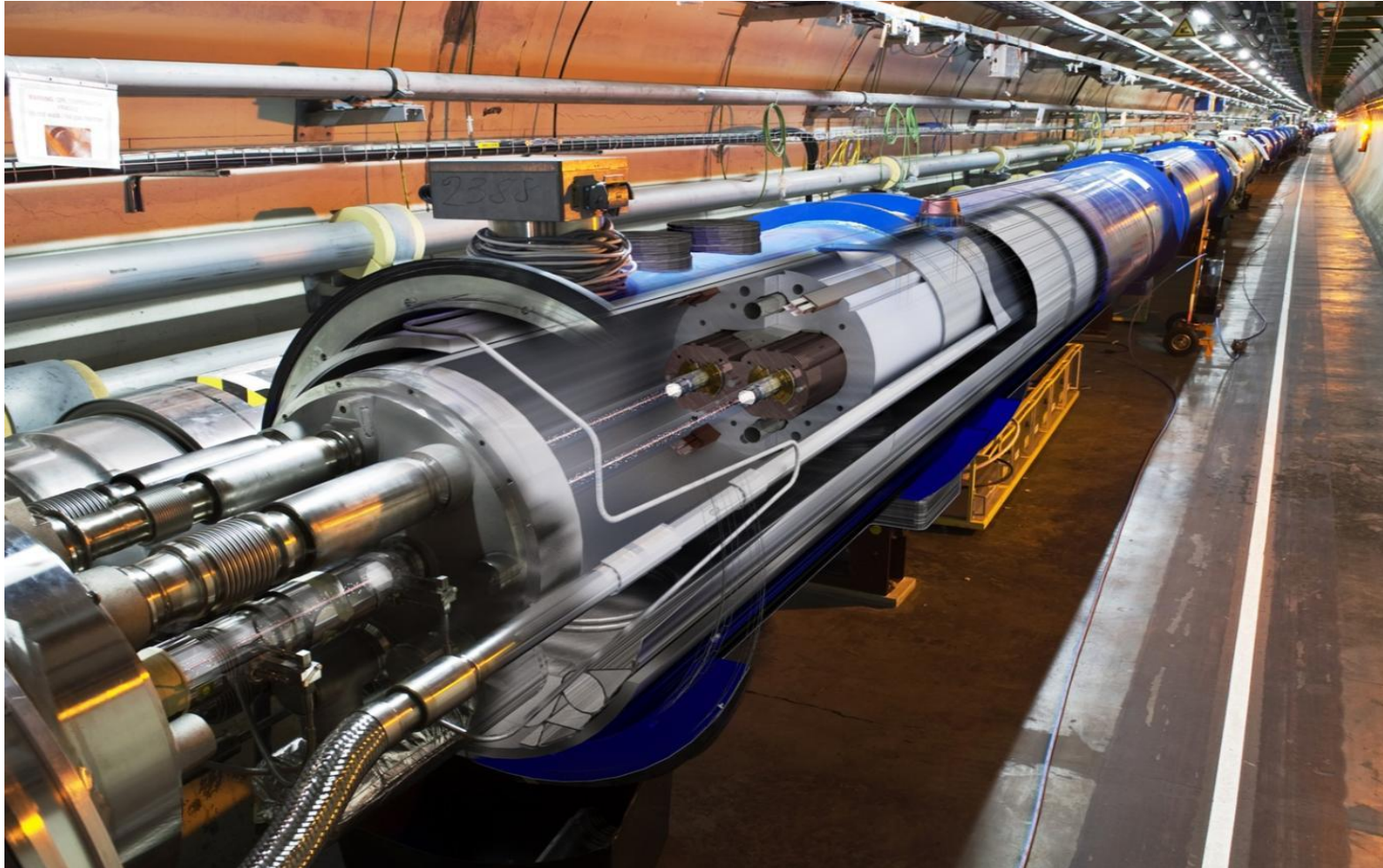



# Cooling LHC magnets with superfluid helium

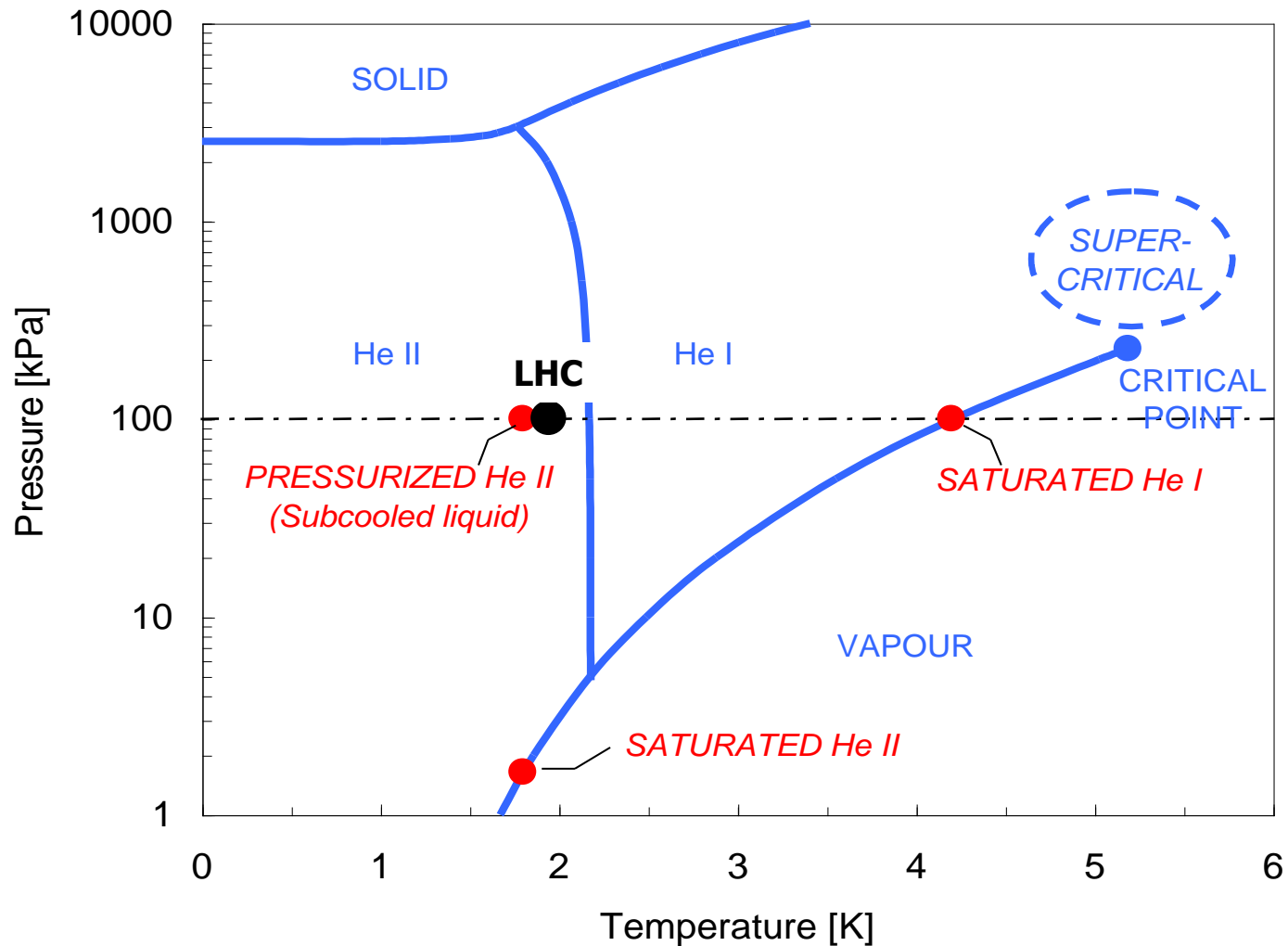

# Well beyond the previous state-of-the-art Superfluid helium on an unprecedented scale

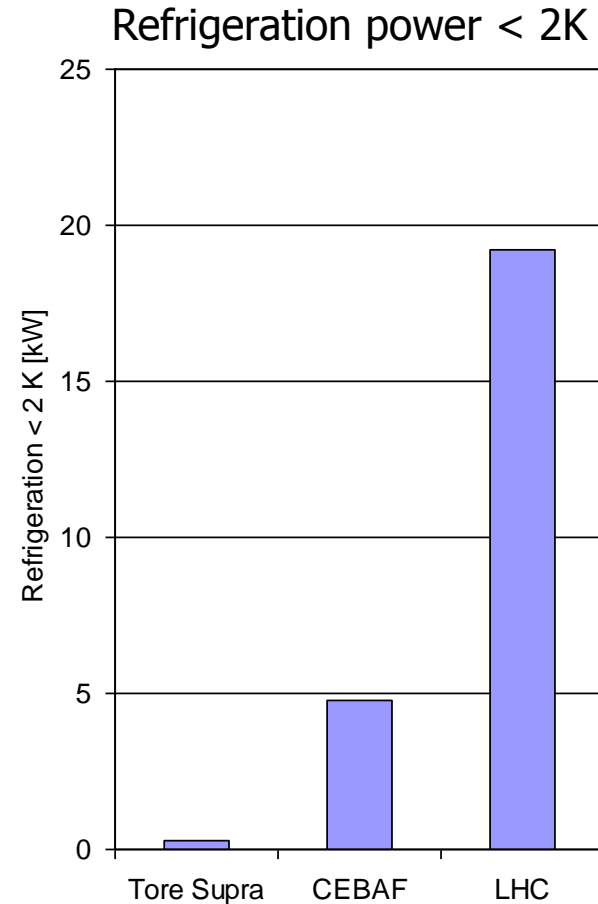
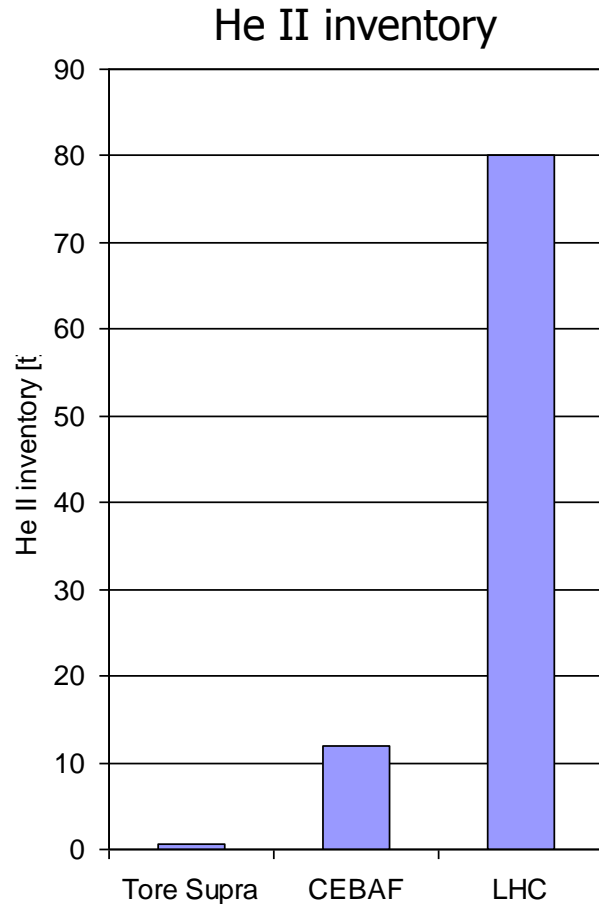

# Thermodynamic cost of low-temperature refrigeration

## C.O.P. of cryogenic plants

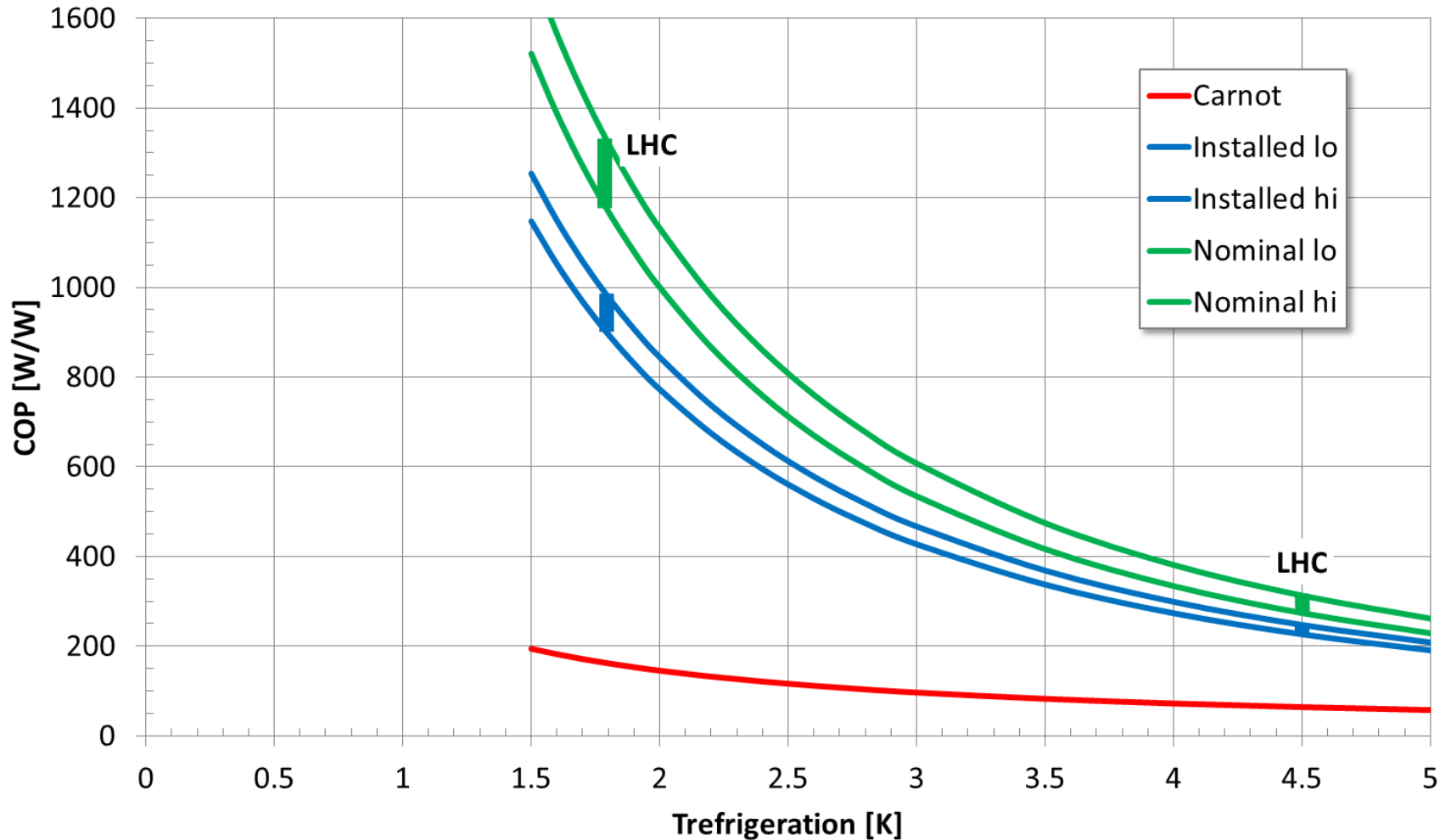

# State-of-the-art technology for affordable hi-tech Modular switched-mode power converters

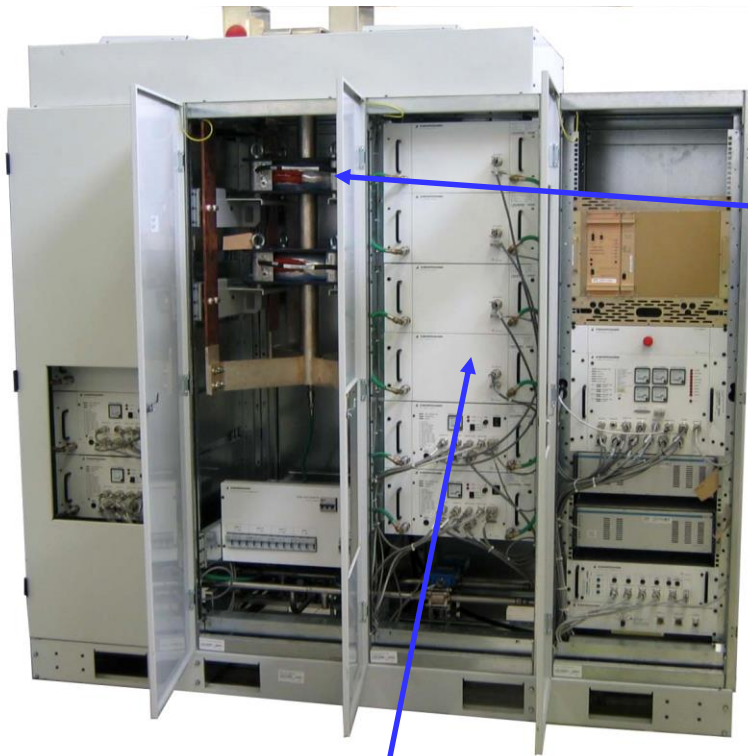

**[2kA,8V] converters**

KEMPOWER, TRANSTECHNIK



**High-precision DCCT**

HITEC

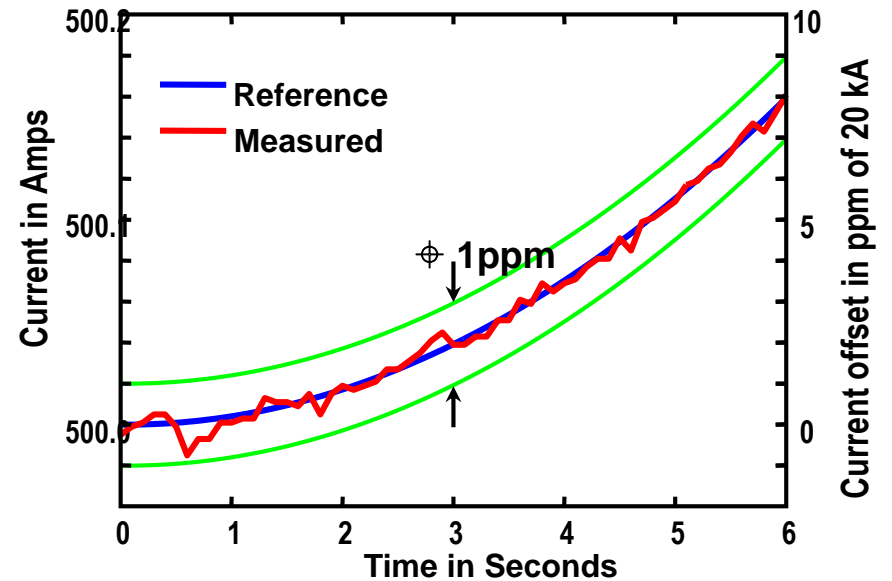

# State-of-the-art technology for affordable hi-tech Industrial solutions for magnet cryostats

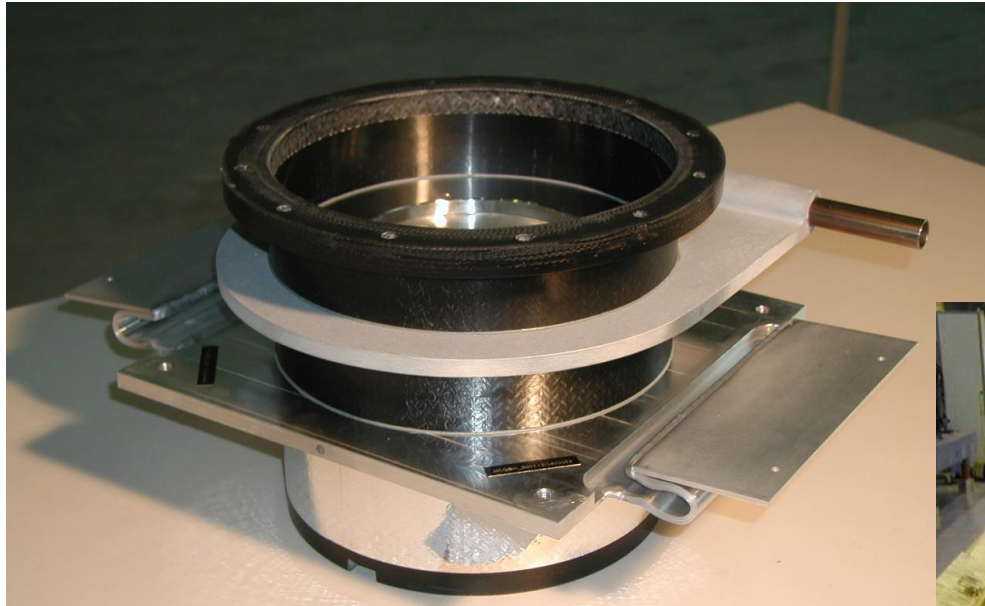

Low heat inleak  
GFRE support post

EWK

CASA ESPACIO



Aluminium extrusion  
for thermal shield

# Developing emerging technologies

## HIP powder metallurgy for He-tight stainless steel covers

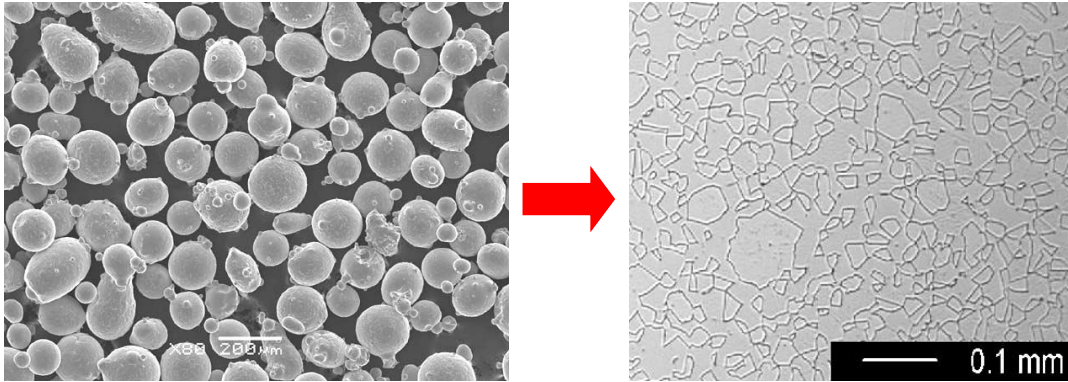

Better, cheaper than conventional forgings



METSO



# Developing emerging technologies

## NEG-coating of vacuum chambers by magnetron sputtering

Non-evaporable getters sputtered on the inner surface of vacuum chambers provide distributed pumping, reduce secondary electron emission yield



# Developing emerging technologies

## 1200 current feedthroughs (0.6 to 12 kA) based on HT superconductors

13 kA HTS current lead

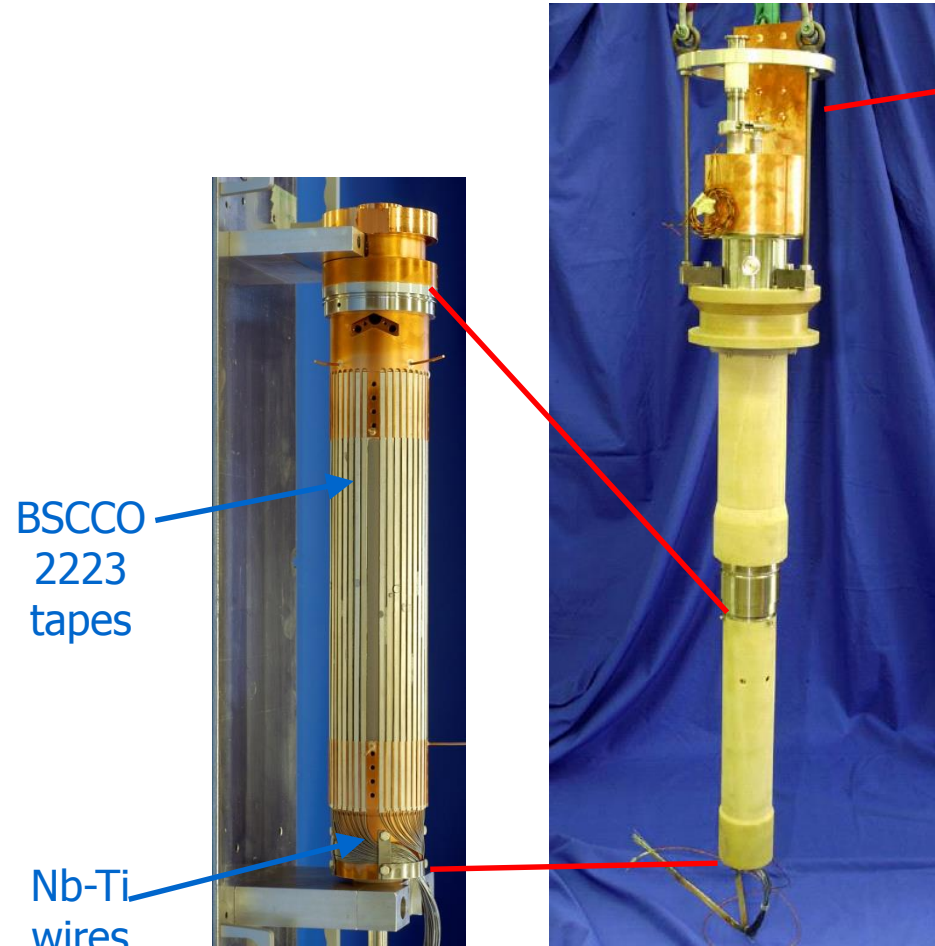

Economy  $\sim 3400$  W @ 4.5 K  $\sim 5000$  l/h liquid He

$\Rightarrow$  *capital: save extra cryoplant*

$\Rightarrow$  *operation: save  $\sim 3.2$  MW*



## Technological choices and industrial strategy

- The right level of technology
  - Adaptation & improvement of state-of-the-art for affordability
  - Reasoned & focussed development of emerging technologies
- Doing it in the lab or going to industry?
  - Principle: *go to industry whenever possible*
  - Cases for not going to industry
    - Unability to specify
    - Difficulty to define and manage interfaces
    - No industrial competency available
    - Absence of interest for a one-of production
- Series numbers, variants and production techniques
  - Even « large » accelerator projects are relatively « small » industrial ventures
  - Case for automation seldomly justified
  - Learning curves effectively applicable
- Making best use of prototypes
  - Building know-how and validate developments
  - Non-exclusive partnerships with industry to preserve future competition
  - Sustain interest from companies until main contracts are placed

## Cost structure of the LHC accelerator (main ring)

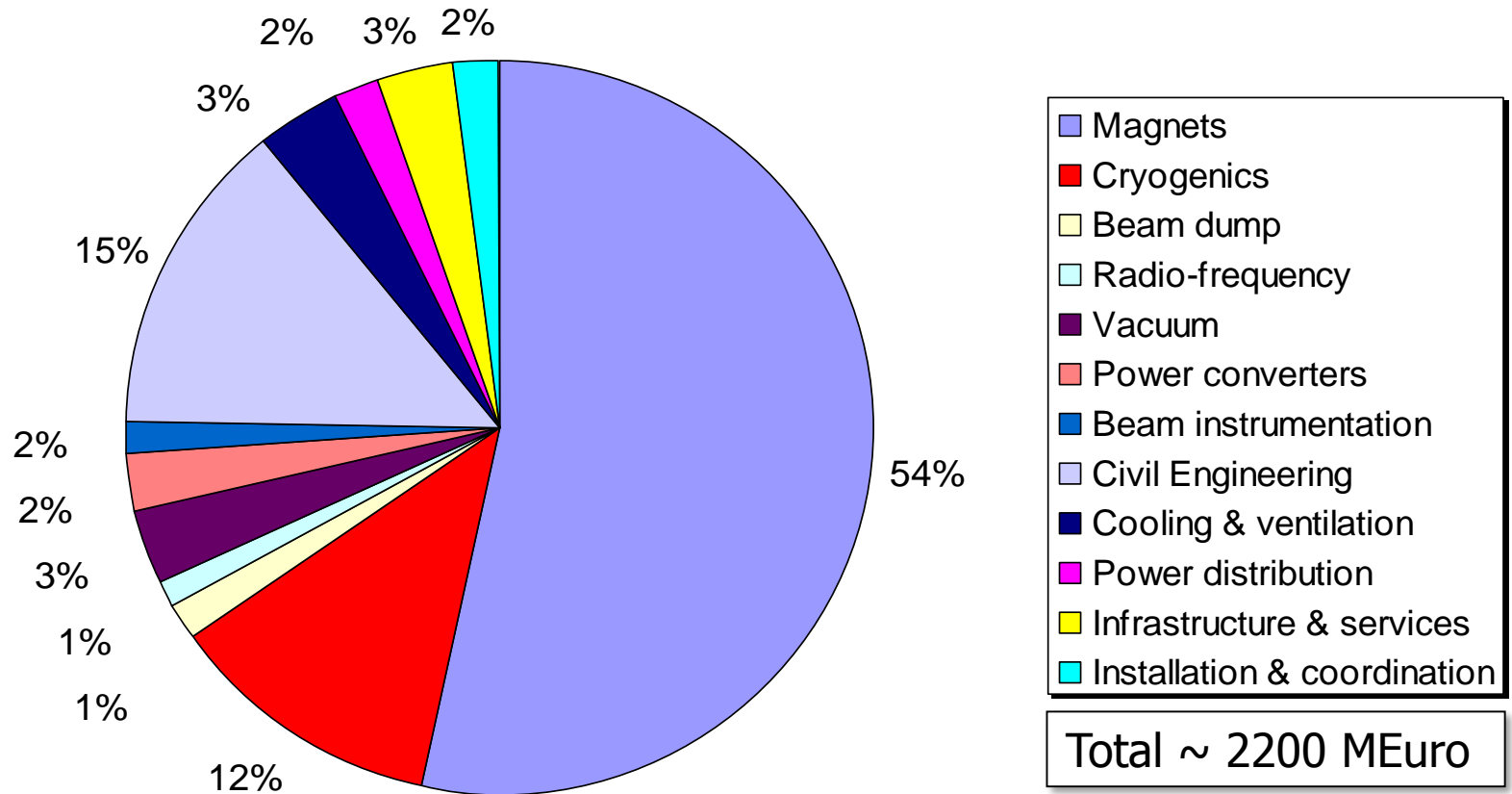

## Procurement from industry CERN legal & regulatory framework

- CERN purchasing rules
  - Preference given to suppliers from CERN Member States
  - Simple (simplistic?) rule: adjudication to lowest bidder meeting the technical specification
  - Possibility to use « best value for money » for service contracts
  - Basically no price negotiation after opening of the bids
- Seeking « fair return » among CERN Member States
  - *A de facto* requirement for a multinational organization
  - Difficult to achieve with lowest-bidder rule
  - Amendment to the rules: bidders from « poorly balanced » Member States may align their price on lowest bidder and be awarded contract, within limits
- Handling special « in-kind » contributions
  - Must be defined in terms of deliverables
  - Valued at « European market » prices
  - Should not allow to bypass lowest-bidder rule: value must be competitive in order not to prejudice Member State industries

# Bringing industry to the laboratory Cryostat assembly by industry on CERN site

ICS Consortium



Cryostating

425 FTE.years

## Bringing industry to the laboratory Interconnections in the LHC tunnel

65'000 electrical joints

Induction-heated soldering

Ultrasonic welding

*Very low residual resistance*

*HV electrical insulation*

40'000 cryogenic junctions

Orbital TIG welding

*Weld quality*

*Helium leaktightness*

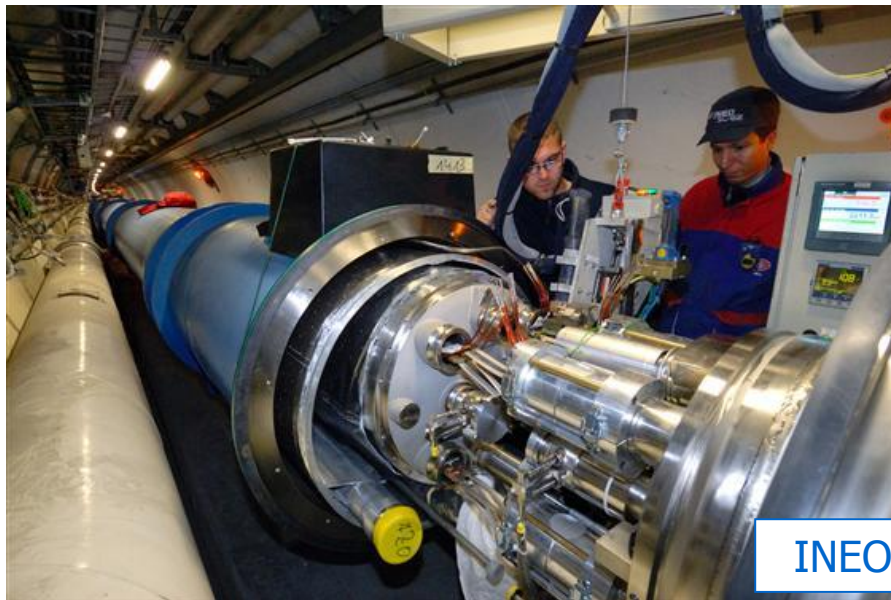

INEO-ENDEL

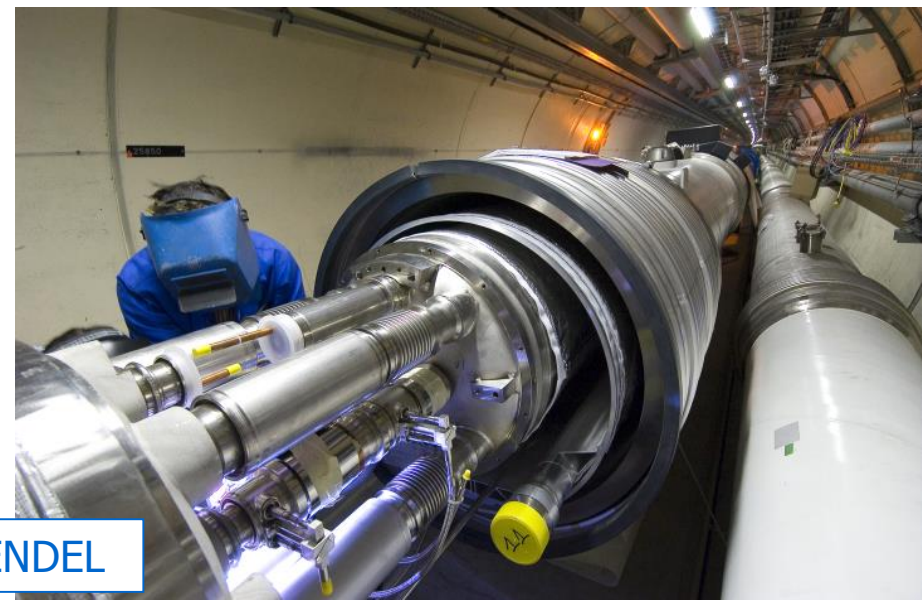

# Producing in-house with industrial methods

## Cryogenic magnet test station at CERN



## Technological choices and industrial strategy

- The right level of technology
  - Adaptation & improvement of state-of-the-art for affordability
  - Reasoned & focussed development of emerging technologies
- Doing it in the lab or going to industry?
  - Principle: *go to industry whenever possible*
  - Cases for not going to industry
    - Unability to specify
    - Difficulty to define and manage interfaces
    - No industrial competency available
    - Absence of interest for a one-of production
- **Series numbers, variants and production techniques**
  - Even « large » accelerator projects are relatively « small » industrial ventures
  - Case for automation seldomly justified
  - Learning curves effectively applicable
- Making best use of prototypes
  - Building know-how and validate developments
  - Non-exclusive partnerships with industry to preserve future competition
  - Sustain interest from companies until main contracts are placed

# LHC components & industrial products

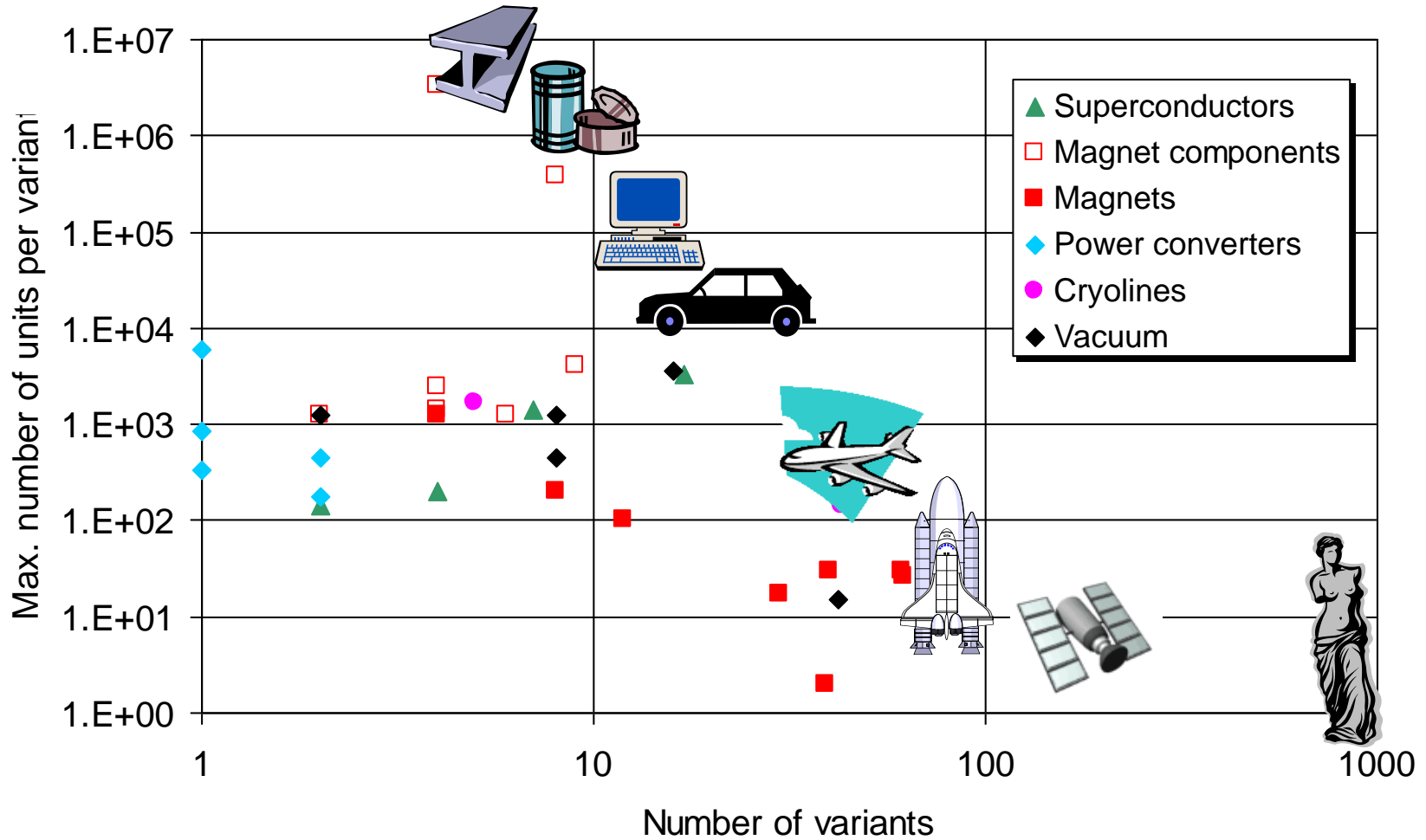



# Series production of LHC components

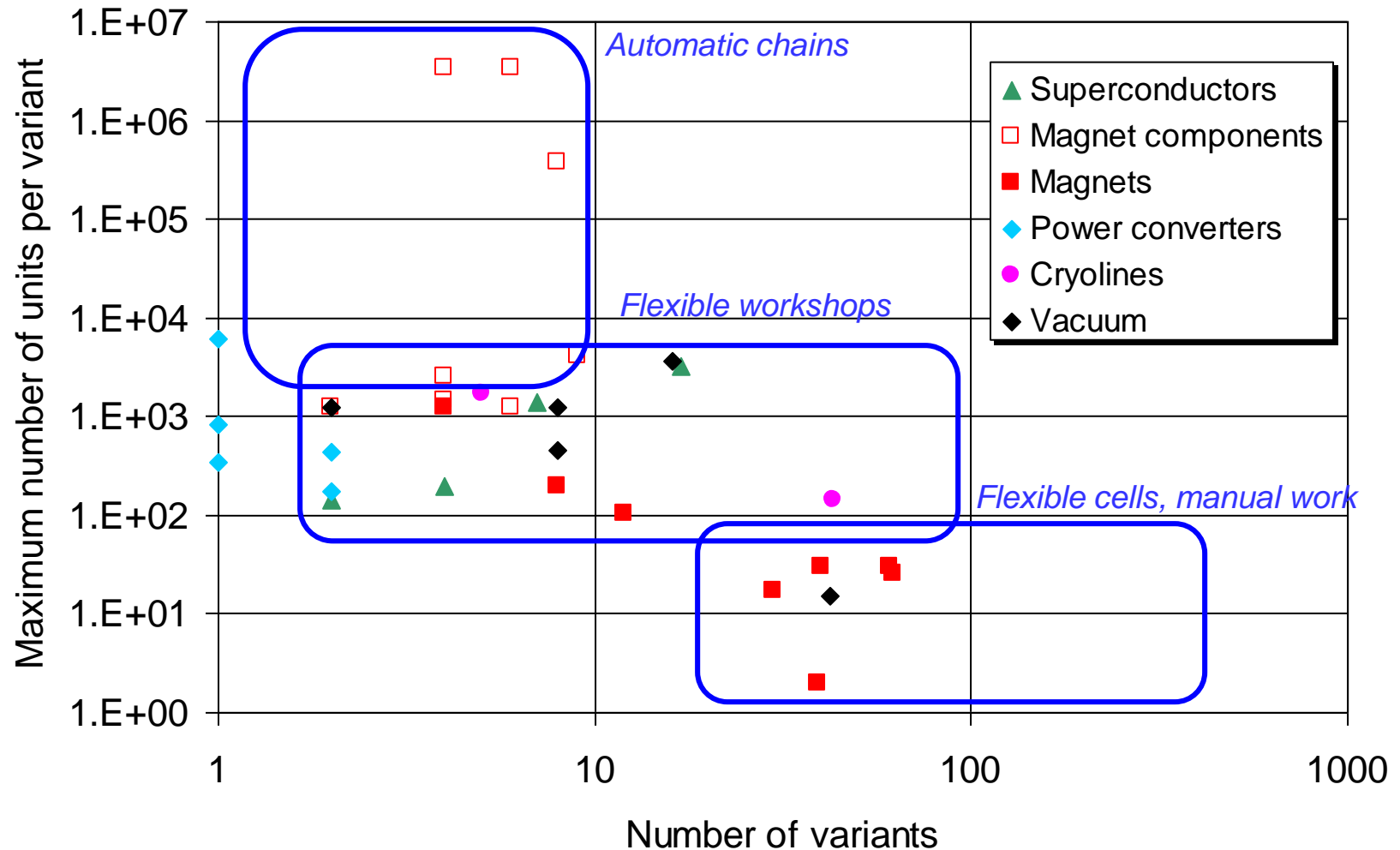

## Experimental learning curves LHC superconducting dipole magnets

- Unit cost  $c(n)$  of  $n$ th unit produced

$$c(n) = c(1) n^{\log_2 a}$$

with  $a = \ll \text{learning percentage} \gg$ , i.e. remaining cost fraction when production is doubled

- Cumulative cost of first  $n$ th units

$$C(n) = c(1) n^{1+\log_2 a} / (1+\log_2 a)$$

with  $C(n)/n =$  average unit cost of first  $n$ th units produced

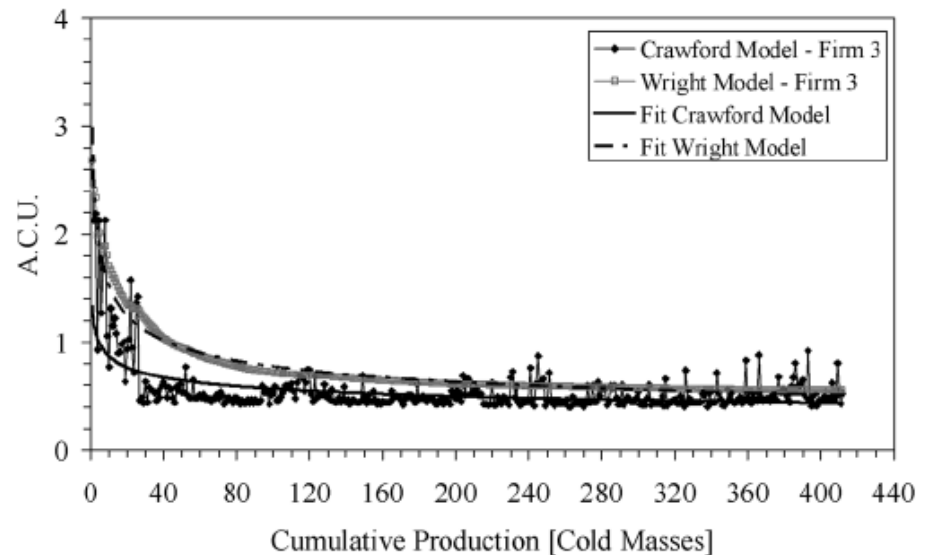
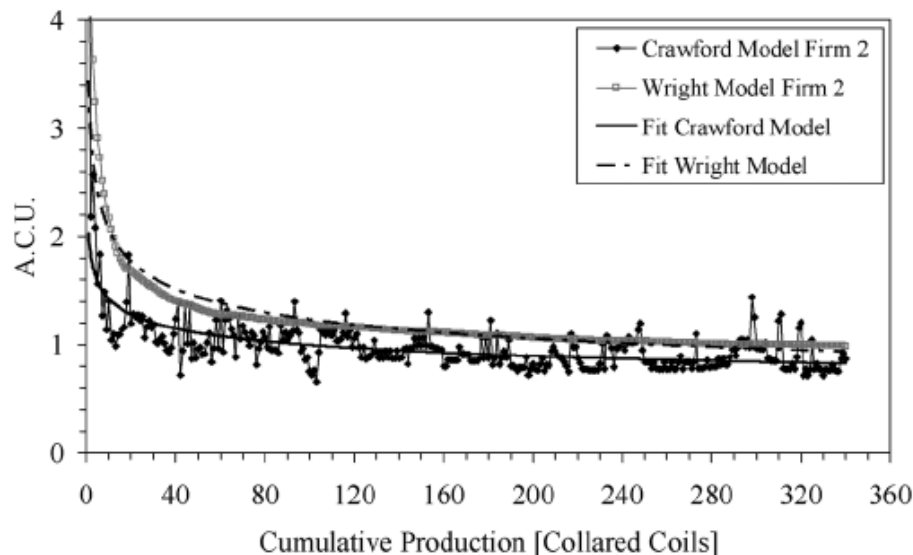

## Learning coefficients

TABLE IV  
LEARNING PERCENTAGE OF SELECTED REFERENCE INDUSTRIES

Industry	$\rho$
Complex machine tools for new models	75%-85%
Repetitive electrical operations	75%-85%
LHC magnets	80%-85%
Shipbuilding	80%-85%
Aerospace	85%
Purchased Parts	85%-88%
Repetitive welding operations	90%
Repetitive electronics manufacturing	90%-95%
Repetitive machining or punch-press operations	90%-95%
Raw materials	93%-96%

## Technological choices and industrial strategy

- The right level of technology
  - Adaptation & improvement of state-of-the-art for affordability
  - Reasoned & focussed development of emerging technologies
- Doing it in the lab or going to industry?
  - Principle: *go to industry whenever possible*
  - Cases for not going to industry
    - Unability to specify
    - Difficulty to define and manage interfaces
    - No industrial competency available
    - Absence of interest for a one-of production
- Series numbers, variants and production techniques
  - Even « large » accelerator projects are relatively « small » industrial ventures
  - Case for automation seldomly justified
  - Learning curves effectively applicable
- Making best use of prototypes
  - Building know-how and validate developments
  - Non-exclusive partnerships with industry to preserve future competition
  - Sustain interest from companies until main contracts are placed

# From emulation in R&D to competition in market

## Cold compressors for refrigeration at 1.8 K

Air Liquide &  
IHI-Linde



Axial-centrifugal impeller



Cartridge 1<sup>st</sup> stage

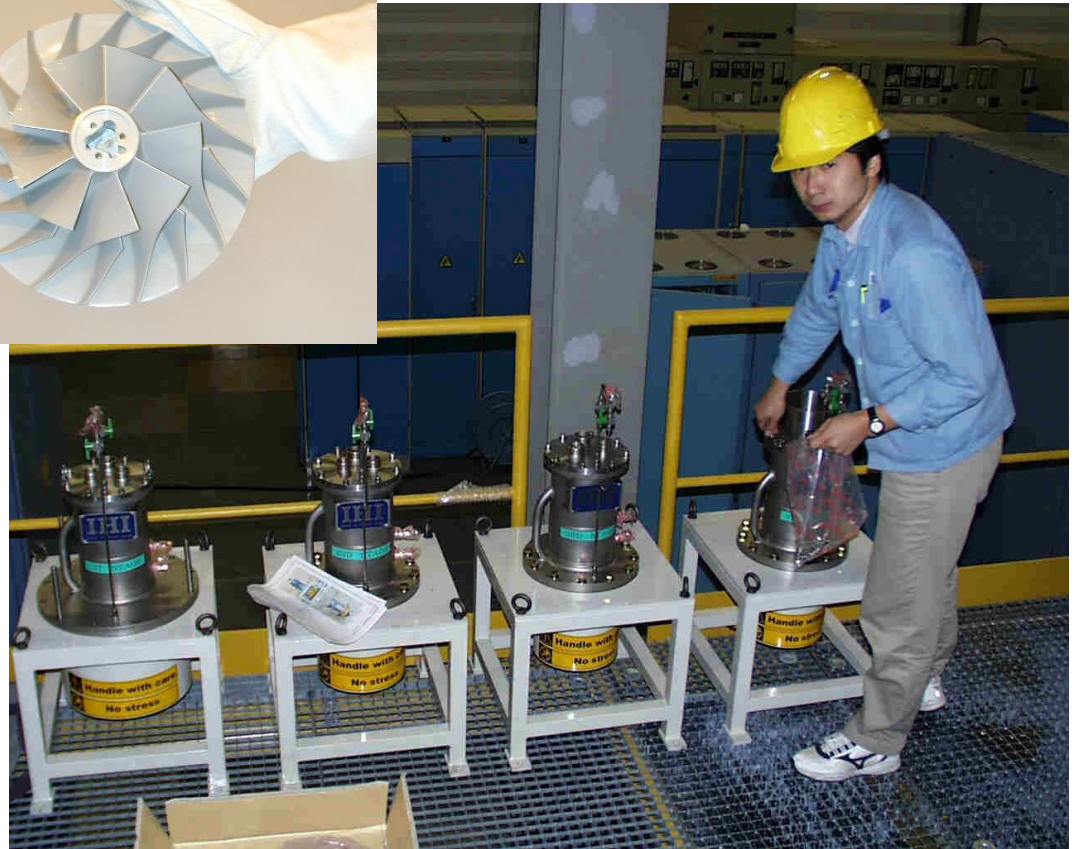

4 cold compressor stages

# From emulation in R&D to competition in market

## Development of LHC cold compressors

- Preexisting state-of-the-art
- Preliminary studies
- Prototypes
- Preseries/series

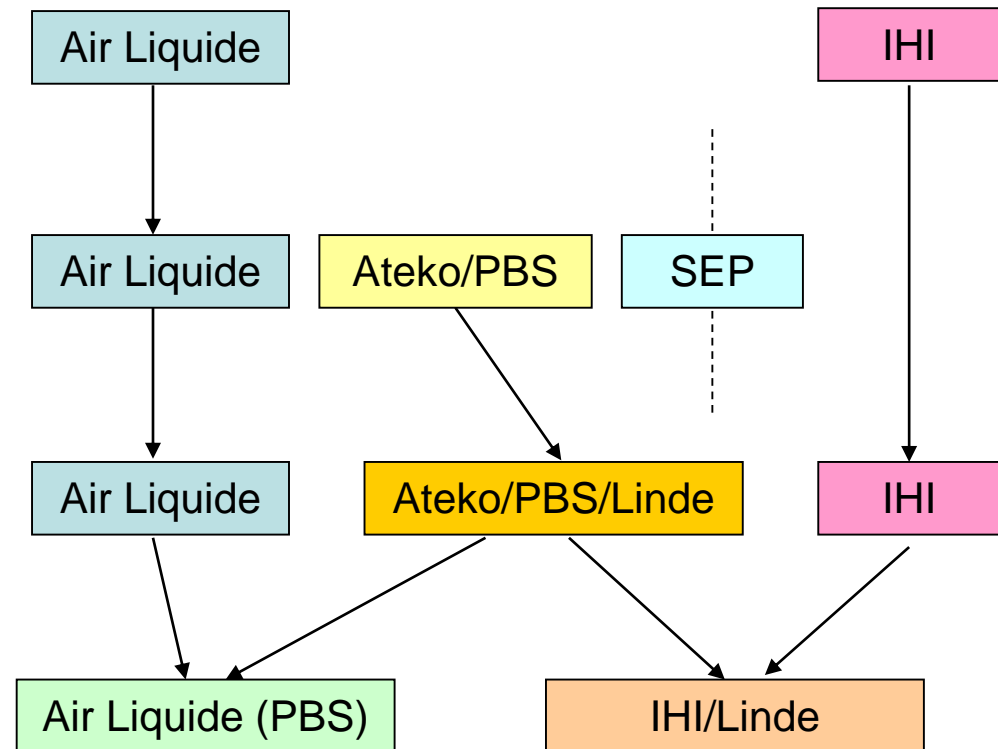

## Contracting and manufacturing

- Technical specification
  - Principle: *do not push to industry risks which they are not in a position to assess*
  - Functional & interface vs build-to-print specification
  - Definition & ownership of specialized tooling
  - Use of performance incentives
- Single or multiple-sourcing
  - Leverage on security of supply and balanced returns in Member States
  - Need for additional production and QA follow-up
  - Intermediate supplies
- Engineering data management
  - Making sure everyone works on the same project
  - Maintaining technical memory in time
- Enforcing QA
  - Documents and procedures
  - Inspections and audits
  - Tests
- Managing the production ramp-up
  - Lead times and conditions for ramp-up
  - Just-in-time vs. production buffers
- Recovering from industrial difficulties

## Performance through shared incentives Specifying cryogenic plants for efficiency



- Include capital & operating costs over amortization period (*10 years*) in adjudication formula
  - Operating costs dominated by *electricity*
  - Include *externalities* in electricity costs (distribution and heat rejection)
  - Shared incentive in the form of *bonus/malus* on measured vs quoted consumption
- ⇒ *breach of "high efficiency = high investment" legend: for given (specified) output, a more efficient plant is not only cheaper to operate, but also smaller, resulting in lower investment (direct & indirect)*



## C.O.P. of cryogenic helium refrigerators

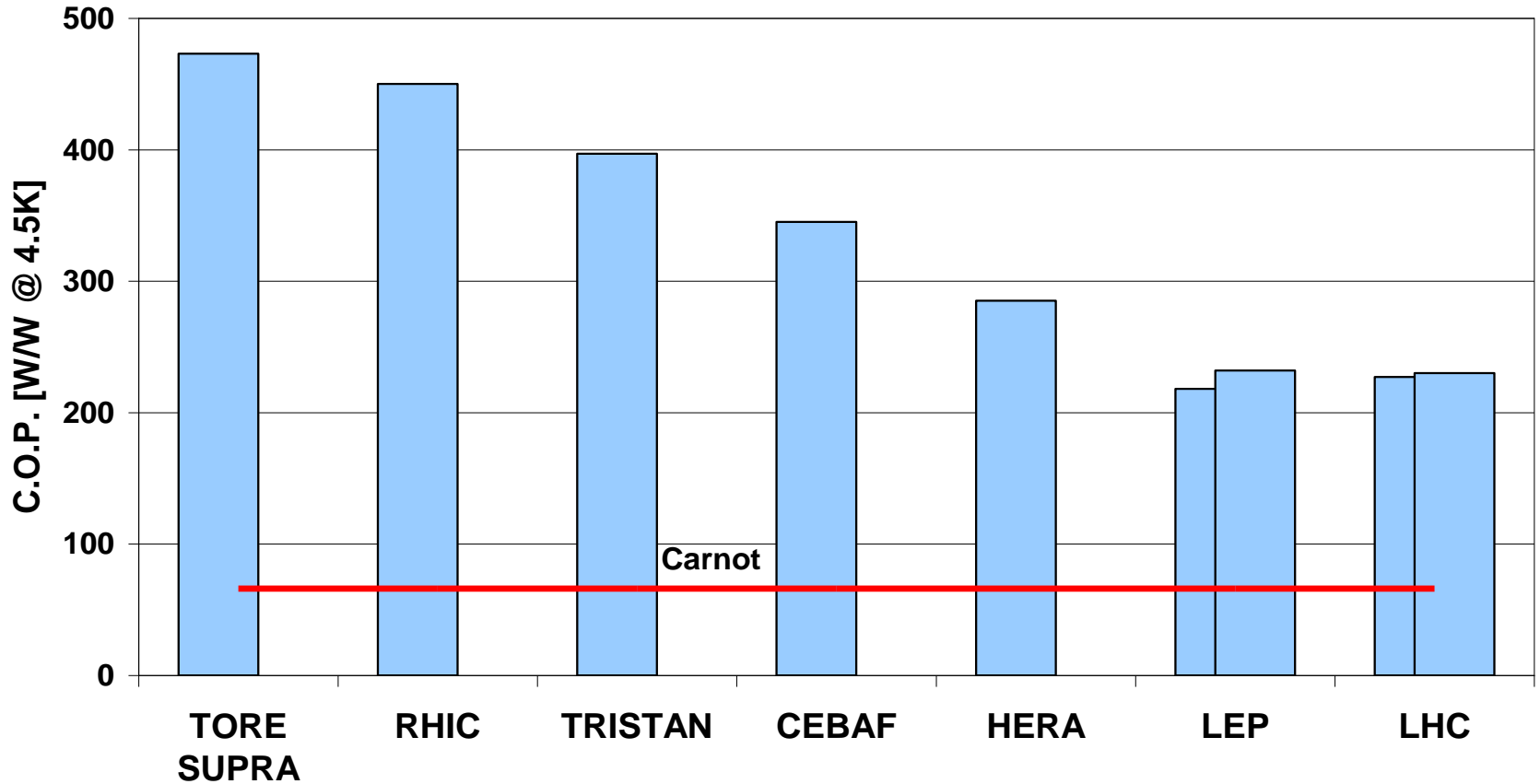

# Manufacturing of superconducting magnets



ACCEL, ALSTOM,  
JEUMONT, NOELL,  
ANSALDO

## Contracting and manufacturing

- Technical specification
  - Principle: *do not push to industry risks which they are not in a position to assess*
  - Functional & interface vs build-to-print specification
  - Definition & ownership of specialized tooling
  - Use of performance incentives
- **Single or multiple-sourcing**
  - Leverage on security of supply and balanced returns in Member States
  - Need for additional production follow-up
  - **Intermediate supplies require heavy logistics**
- Engineering data management
  - Making sure everyone works on the same project
  - Maintaining technical memory in time
- Enforcing QA
  - Documents and procedures
  - Inspections and audits
  - Tests
- Managing the production ramp-up
  - Lead times and conditions for ramp-up
  - Just-in-time vs. production buffers
- Recovering from industrial difficulties

Component	Nb Units	Quantity
Superconducting cables (for inner & outer layers)	9856	~ 6000 km
Polyimide tapes for cable and copper wedges insulation (two types)	-	55 t
Copper wedges (4 types)	~ 158000	330 t
Polyimide (in rolls) for the coil ground insulation	-	18 t
Head Spacers, Chips and Wedge-Tips*	90 sets	-
Coil Interlayer*	90 sets	-
Layer Jump Box and Filling Pieces*	90 sets	-
Cable Stabiliser*	90 sets	-
Quench Heaters*	720	-
Austenitic steel for collars	-	11200 t
Austenitic steel for nested laminations	-	1400 t
Collars (6 types)	~ 11.4 M	-
Low-carbon steel for half-yoke and insert laminations	-	~ 43000 t
Half yoke standard laminations & inserts	~ 11.6 M	~ 21600 t
End yoke laminations, austenitic/magnetic	770000/406560	-
Insulated cold bore tubes	2464	~ 38.6 km
Bus bars assemblies equipped with the spool cables	1232	~ 115 km
Shells for shrinking cylinders	2464	~ 2700 t
Spool pieces (sextupole and decapole/octupole corrector magnets)	3964	-
End covers	2464	240 t
Helium heat exchanger tubes	1232	~ 18.5 km
Interconnection bellows	6160	-
Instrumentation and wiring for the cold mass	1232 sets	~ 300 km
Protection diode stacks	1232	-
Line N tubes	1232	~ 18.5 km

For the 90 preseries only

## CERN-supplied components for the LHC dipoles

## Managing an integrated supply chain

### *Benefits*

- Technical homogeneity
- Quality assurance
- Economy of scale
- Safety of supply
- Balanced industrial return

### *Risks & drawbacks*

- Responsibility interface
- Additional workload
- JIT breakdown
- Transport, storage, logistics

# Production control of components drives quality of the finished magnets

Radius  $275 \pm 0.05$

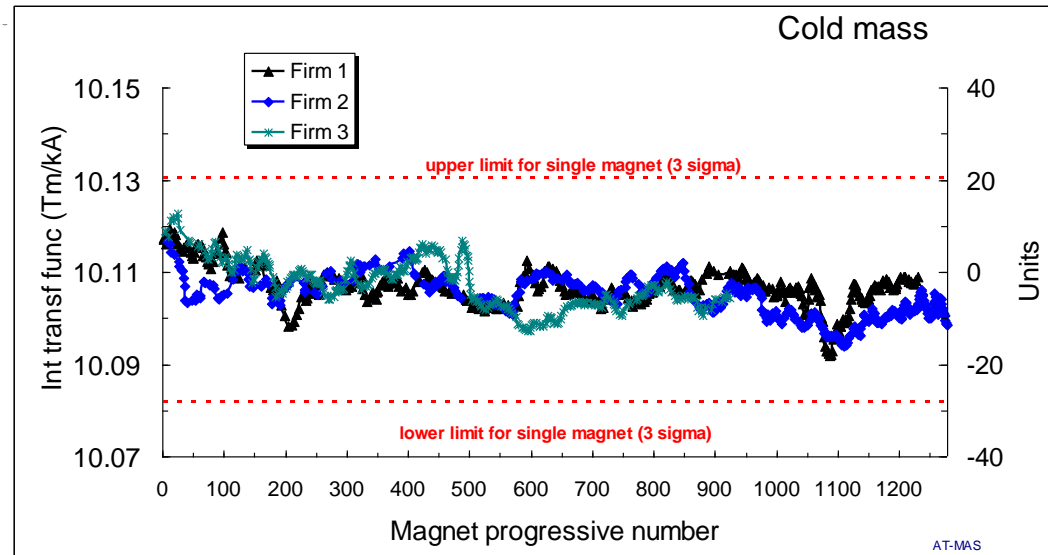
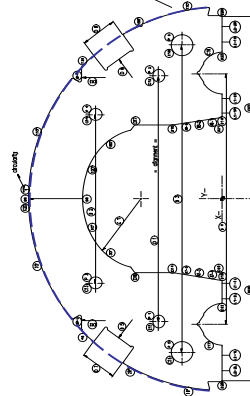
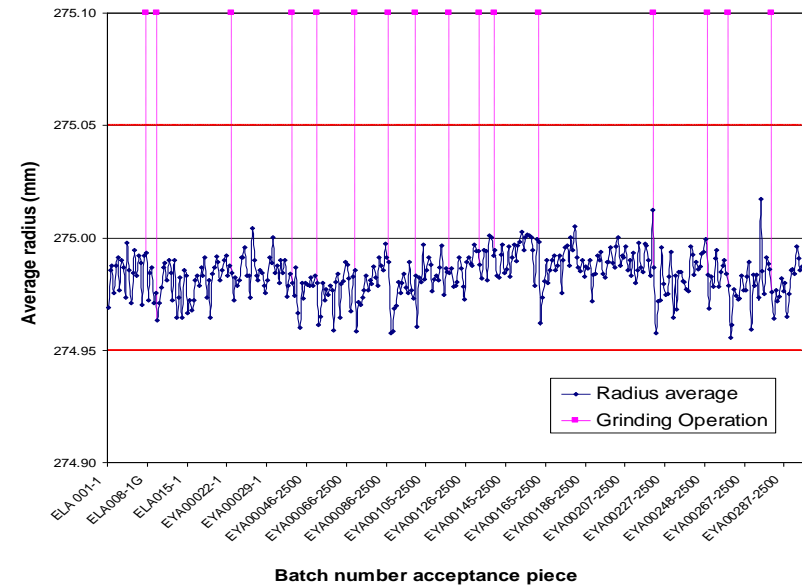

## Heavy logistics and transport

Installed in tunnel: **50 000 t**

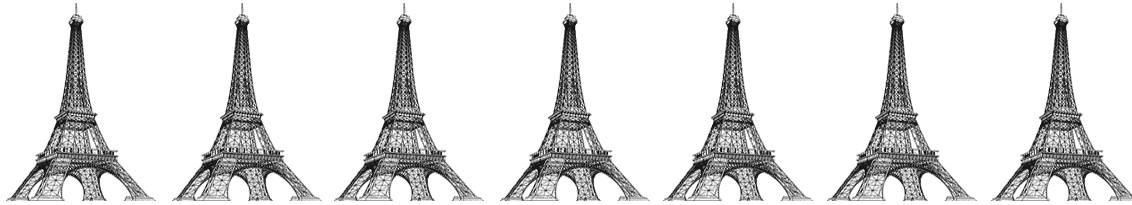

Transported across Europe: **~150 000 t**

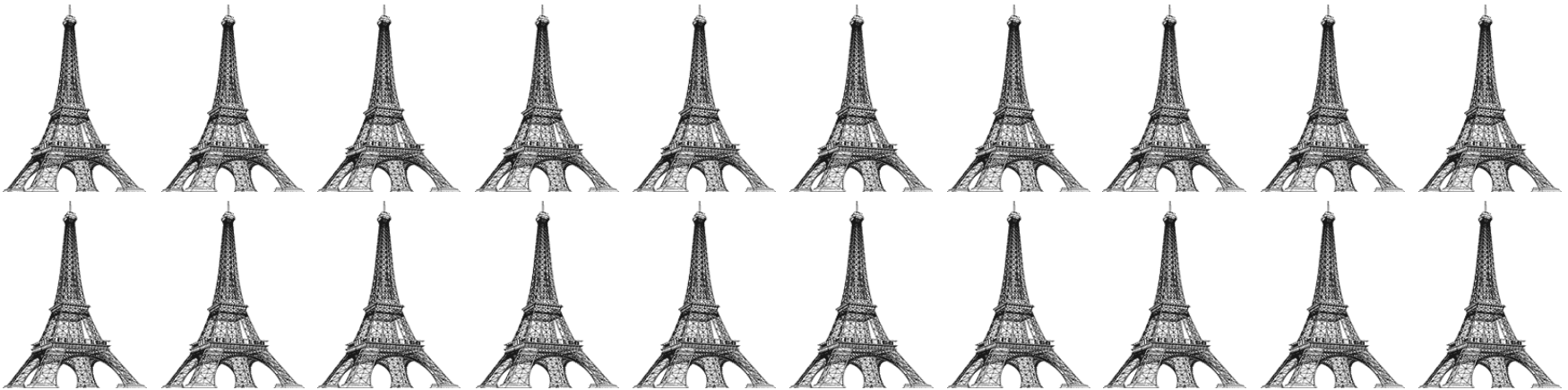

## Contracting and manufacturing

- Technical specification
  - Principle: *do not push to industry risks which they are not in a position to assess*
  - Functional & interface vs build-to-print specification
  - Definition & ownership of specialized tooling
  - Use of performance incentives
- Single or multiple-sourcing
  - Leverage on security of supply and balanced returns in Member States
  - Need for additional production and QA follow-up
  - Intermediate supplies
- **Engineering data management**
  - Making sure everyone works on the same project
  - Maintaining technical memory in time
- Enforcing QA
  - Documents and procedures
  - Inspections and audits
  - Tests
- Managing the production ramp-up
  - Lead times and conditions for ramp-up
  - Just-in-time vs. production buffers
- Recovering from industrial difficulties



# 90 main hi-tech industrial contracts

## Multiple production sites

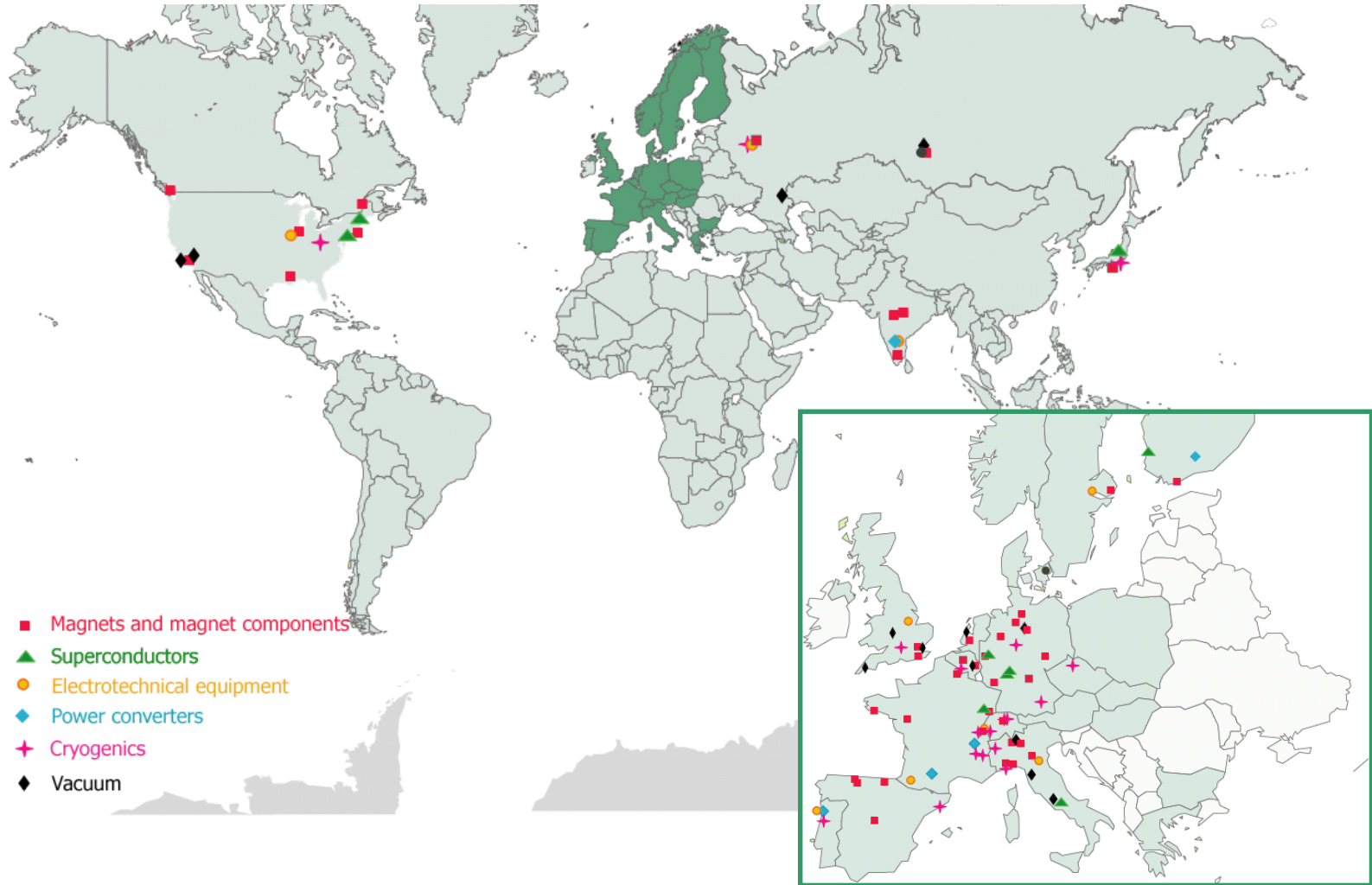

# Special contributions from Non-member States

Mostly in-kind, ~15% of the project value

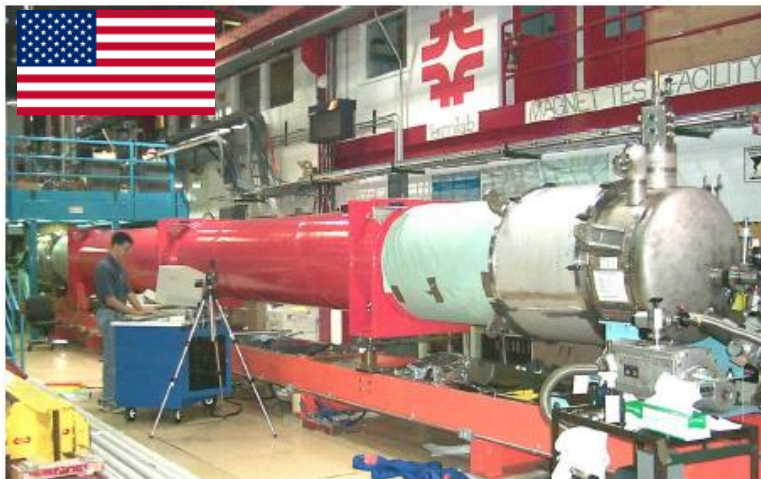
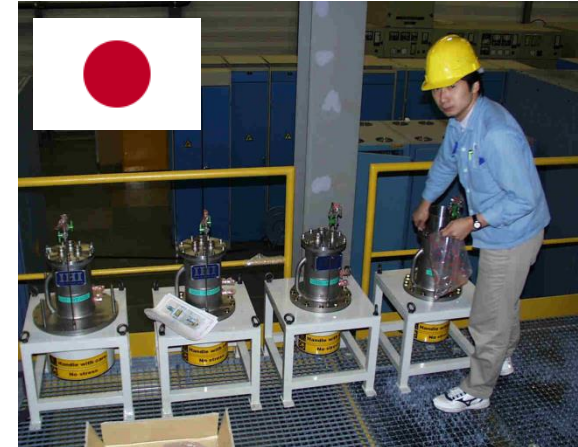
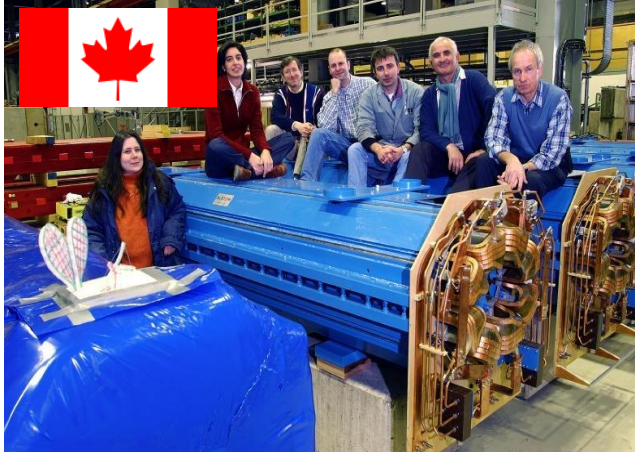

## Lifecycle longer than a professional career

- Preliminary conceptual studies 1984
- First magnet models 1988
- Start structured R&D program 1990
- Approval by CERN Council 1994
- Industrialization of series production 1996-1999
- DUP & start civil works 1998
- Adjudication of main procurement contracts 1998-2001
- Start installation in tunnel 2003
- Cryomagnet installation in tunnel 2005-2007
- Functional test of first sector 2007
- First commissioning with beam 2008
- Final commissioning 2009
- Operation for physics 2010-2035
- ... ?

# Engineering data management system

## Single data repository, access to documentation via WWW

The screenshot displays the EDMS Web Navigator interface in Microsoft Internet Explorer. The main window shows a hierarchical tree structure under the heading "LHC Hardware Baseline". The tree is expanded to show "Cryo Magnets in Common Arc Cryostats", which includes sub-items like "Cryo Dipoles in the Arcs and the Dispersion Suppressors", "Cold Mass Assembly", "Dipole Cryostat & Related Equipment", "Standard Arc Short Straight Sections", "Short Straight Sections in Dispersion Suppressors", "Other Arc Cryostats and Components", "Long Straight Sections", "Cryogenics", "Vacuum System", "DC Powering and Quench Protection", "Radiofrequency System", "Transfer Lines, Injections and Beam Dumping", "Other Machine Systems", "Civil Engineering Works and Infrastructure", "General Services", "Installation", and "LHC Specific Facilities".

Overlaid on this is a detailed view of a document titled "LHC Hardware Baseline" with the sub-heading "Drawing Information". The drawing shows a cross-section of a magnet assembly with various components labeled. A table titled "DIMENSIONS (mm)" is visible in the top right corner of the drawing area.

The table data is as follows:

NO	REF	VAL	UNIT	DEF
1	1	100	mm	
2	2	100	mm	
3	3	100	mm	
4	4	100	mm	
5	5	100	mm	
6	6	100	mm	
7	7	100	mm	
8	8	100	mm	
9	9	100	mm	
10	10	100	mm	

The interface also shows a search bar, navigation buttons (Back, Forward, Home), and a status bar at the bottom indicating the current page is "Page 1 of 1".

## Contracting and manufacturing

- Technical specification
  - Principle: *do not push to industry risks which they are not in a position to assess*
  - Functional & interface vs build-to-print specification
  - Definition & ownership of specialized tooling
  - Use of performance incentives
- Single or multiple-sourcing
  - Leverage on security of supply and balanced returns in Member States
  - Need for additional production and QA follow-up
  - Intermediate supplies
- Engineering data management
  - Making sure everyone works on the same project
  - Maintaining technical memory in time
- **Enforcing QA**
  - **Documents and procedures**
  - **Inspections and audits**
  - **Tests**
- Managing the production ramp-up
  - Lead times and conditions for ramp-up
  - Just-in-time vs. production buffers
- Recovering from industrial difficulties

# The Manufacturing & Test Folder (MTF), key to quality assurance in production

**CERN**  
CH-1211 Geneva 23  
Switzerland



LHC Project Document No.  
**LHC-PM-QA-309.00 rev 1.0**  
CERN Div./Group or Supplier/Contractor Document No.  
EDMS Document No.  
**103562**

Date: 1999-06-16

## Quality Assurance Procedure

### MANUFACTURING AND INSPECTION OF EQUIPMENT

#### Abstract

This document describes the procedures and responsibilities involved in the manufacturing, the assembly and the inspection and test of LHC systems, sub-systems, assemblies, sub-assemblies and parts.

It establishes a policy for the control of all stages of manufacturing and assembly, from raw material procurement until final inspection and test, and it defines responsibilities and procedures to verify that all specified requirements are met.

The policy and guidelines apply to all materials, parts and equipment manufactured and/or assembled by Contractors, collaborating Institutes and CERN Divisions or Groups, that are to be installed in the LHC.

**Prepared by :**

**P. Lienard**  
LHC/MMS  
Patrick.Lienard@cern.ch  
**M. Mottier**  
EST/ISS  
Marcel.Mottier@cern.ch

**Checked by :**

**LHC Quality Assurance Working Group**

**Approved by :**

**Paul Faugeras**  
Deputy to LHC Project Leader for Quality Assurance

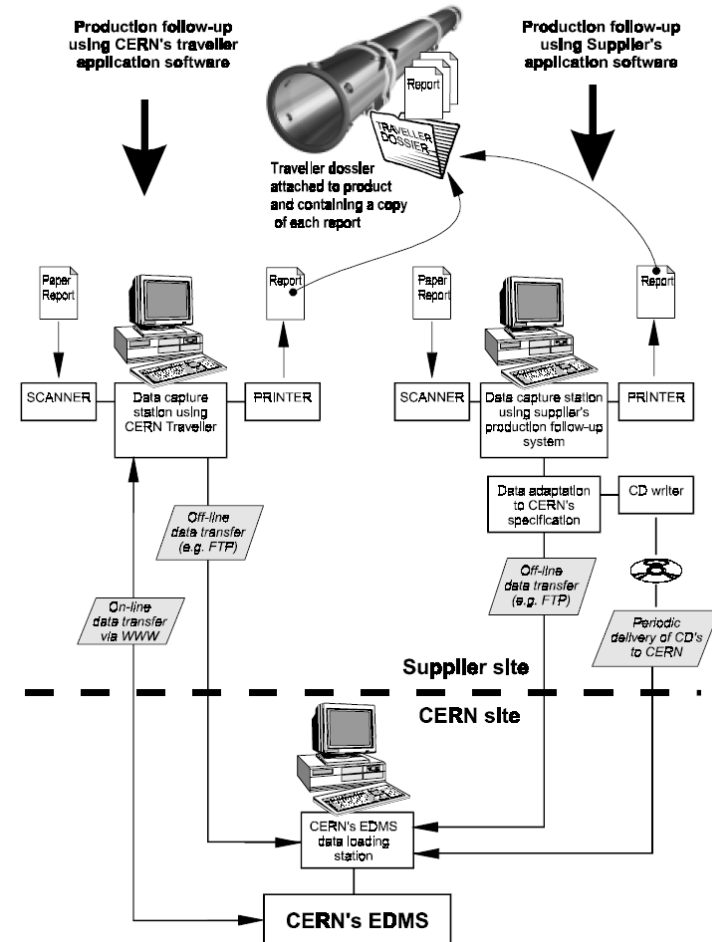

## Enforcing QA procedures Inspection

- Contract with inspection company (ISQ)
  - 20 resident inspectors
  - 6 itinerant inspectors
  - Initial training and periodic de-briefing at CERN
- Mandate of inspectors
  - Follow manufacturing at suppliers and on-site installation
  - Incoming reception of materials at manufacturer's
  - Attend tests according to Inspection & Test Plan and at random
  - Report and follow-up of non conformities
  - Facilitate CERN-Supplier interface
  - Prepare and/or supervise the preparation of Manufacturing & Test Folders at manufacturer's
  - Report to CERN contract engineers

# LHC components inspected in Europe



ISQ



## Electrical tests on main dipoles

- Basic principles
  - Intercept potential faults as early as possible in production chain
  - Decreasing harshness of tests along production chain
  - Ensure sufficient safety factor w.r. to operating conditions

Test	Layers and Poles	Collared Coil	Cold Mass
DC resistance at 1 A	x	x	x
Inductance at 10 Hz, 100 Hz and 1 kHz	x	x	x
DC resistance of the 8 quench heater circuits	-	x	x
Continuity of voltage taps circuits	-	-	x
Capacitance of the qh vs. dipoles and dipoles vs. ground	-	x	x
Oscillation period during a discharge test	120 V/turn on layers and 100 V/turn on the poles	100 V/turn on poles, dip. and magnet	25 V/turn
Insulation resistance of the copper wedges in the layers at 500 V	x	-	-
Insulation resistance @ 1 kV (@ 1.5 kV on the cold mass)	Between inner and outer layer / each pole	Poles to P. Poles, dip. vs. qh and dip. vs. ground	All to ground, qh to magnet Bus bars to ground
Resistance of the splice	Inner to outer layers @ 1 A	-	Pole to pole and dip. to dip. @ 20 A
Leakage current poles to ground	-	@ 6 kV	@ 5 kV
Leakage current	-	Poles to qh and upper to lower pole in dip. @ 3 kV	All to ground @ 5 kV Qh to magnet @ 3 kV
Discharge test @ 850 V, 2.5 kJ, on the quench heater circuits	-	x	-

# Early detection of manufacturing errors through magnetic measurements at room temperature



- 24 "moles", each carrying 3 radial rotating coils
- Fully automated measurement  $\sim 2$  h per magnet
- Data transfer from industry to CERN for analysis and clearance

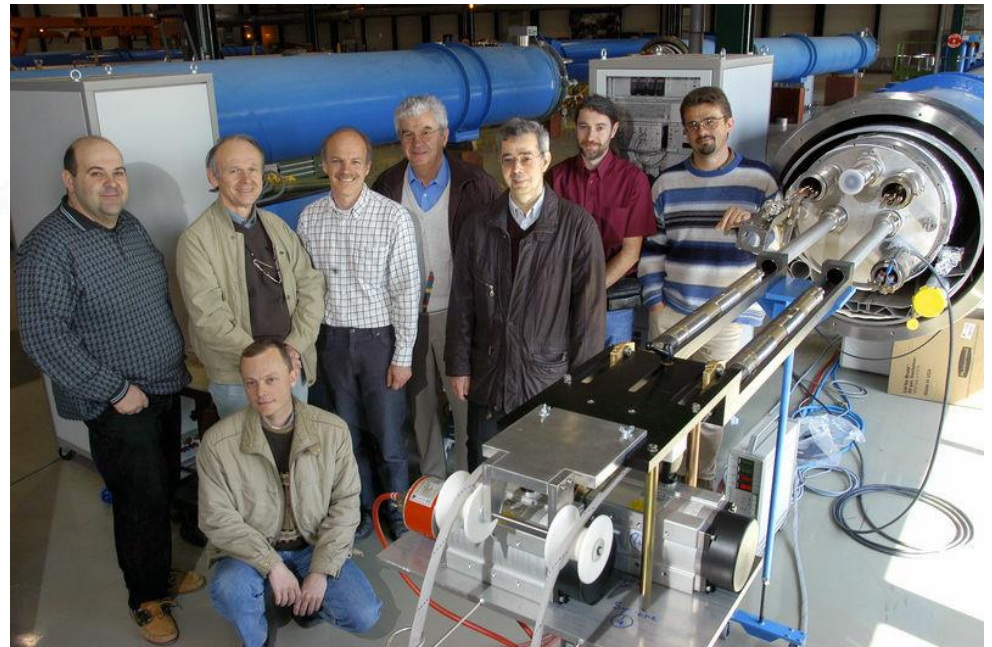
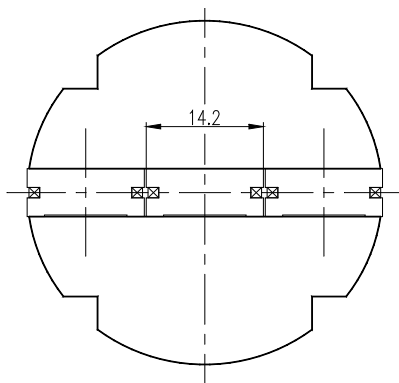

## Cold/warm correlations for field errors

**collared coil**

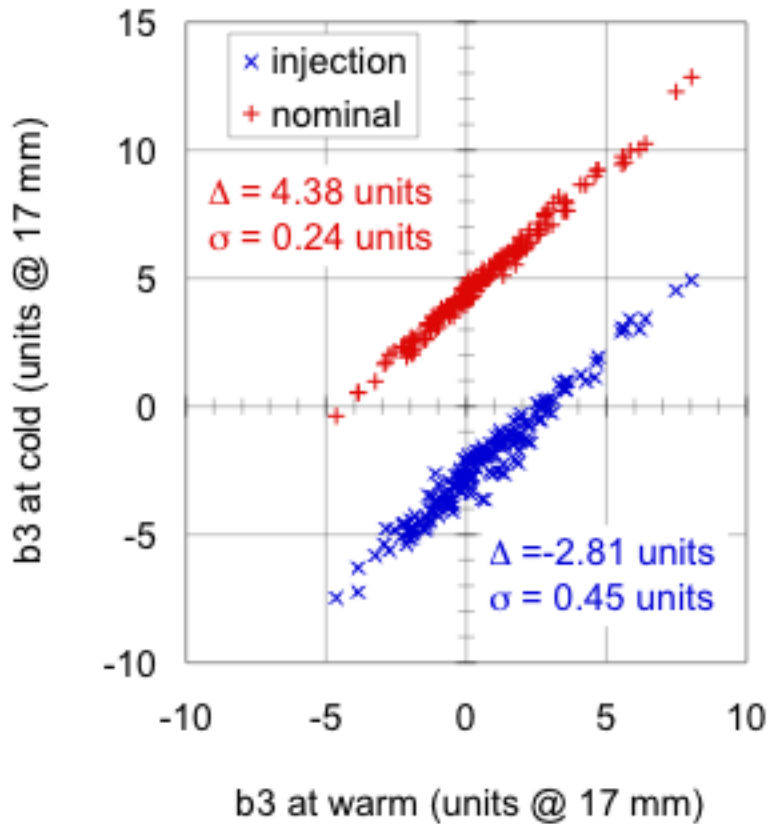

**cold mass**

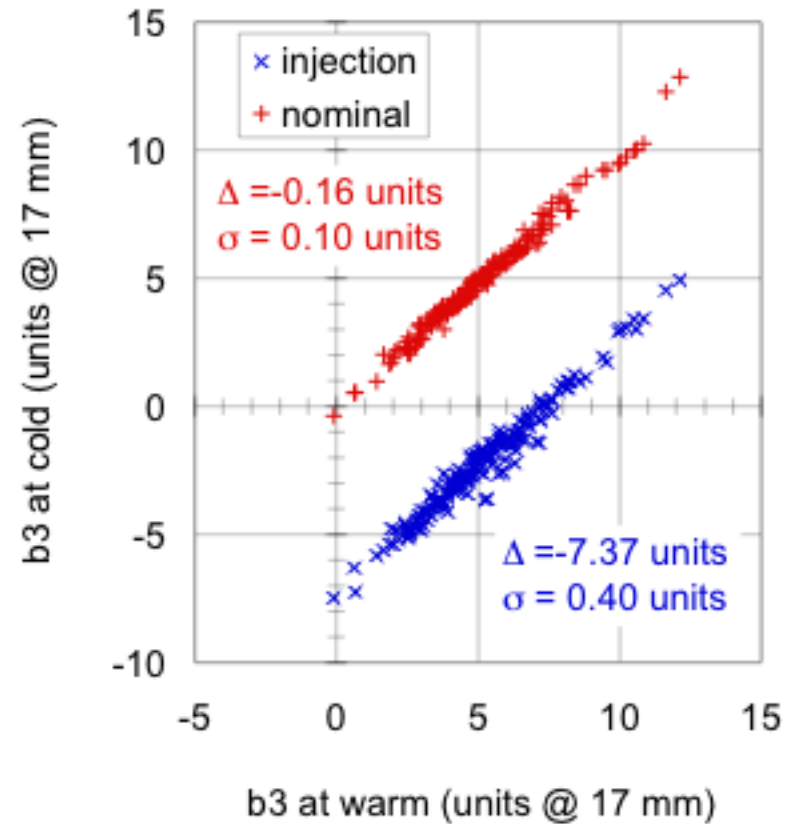

# Some defects found by room-temperature magnetic measurements

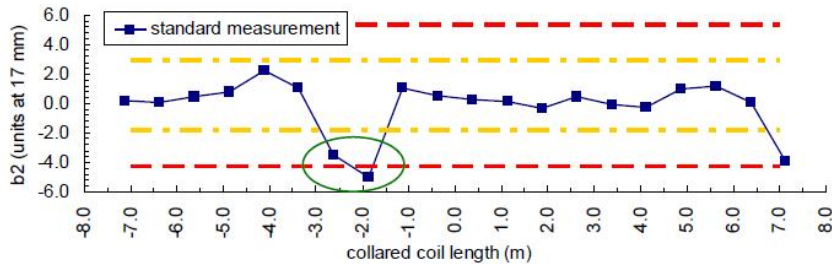

Fig. 2. Measurement of multipole  $b_2$  along the magnet axis with alarm limits at  $4\sigma$  and  $8\sigma$  (dashed lines) for a collared coil with missing pole shim.

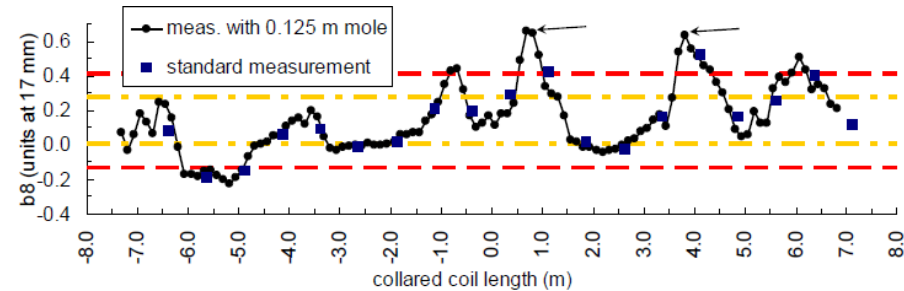

Fig. 8. Measurement of multipole  $b_8$  along the magnet axis with alarm limits at  $4\sigma$  and  $8\sigma$  (dashed lines) for a collared coil with curing problem.

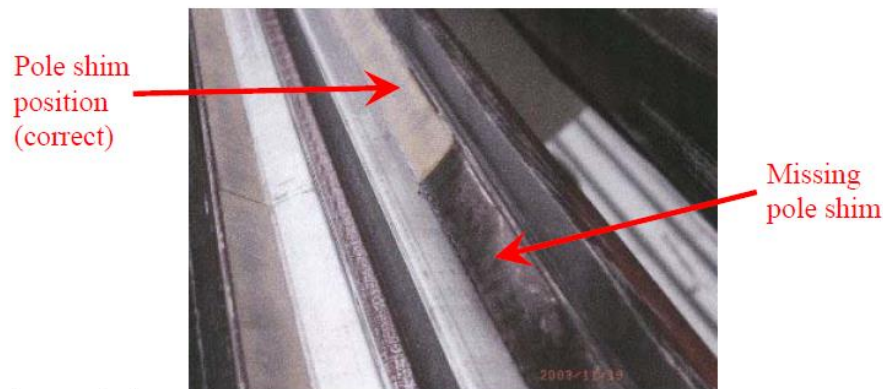

Fig. 3. Missing pole shim observed after de-collaring.

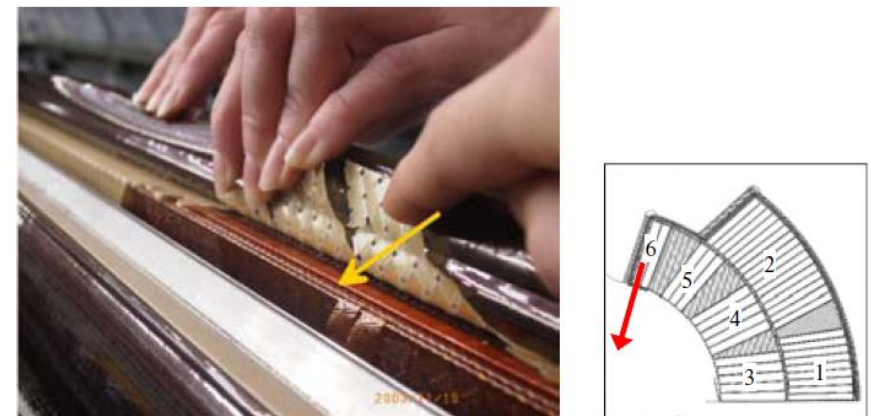

Fig. 9. Left: Movement of block 6 of the inner layer of the coil observed after de-collaring. Right: Illustration of the predicted defect and block numbering.

## Contracting and manufacturing

- Technical specification
  - Principle: *do not push to industry risks which they are not in a position to assess*
  - Functional & interface vs build-to-print specification
  - Definition & ownership of specialized tooling
  - Use of performance incentives
- Single or multiple-sourcing
  - Leverage on security of supply and balanced returns in Member States
  - Need for additional production and QA follow-up
  - Intermediate supplies
- Engineering data management
  - Making sure everyone works on the same project
  - Maintaining technical memory in time
- Enforcing QA
  - Documents and procedures
  - Inspections and audits
  - Tests
- **Managing the production ramp-up**
  - **Lead times and conditions for ramp-up**
  - **Just-in-time vs. production buffers**
- Recovering from industrial difficulties

# Timeline of LHC superconducting dipole magnets

## Early involvement of industry, well before series production

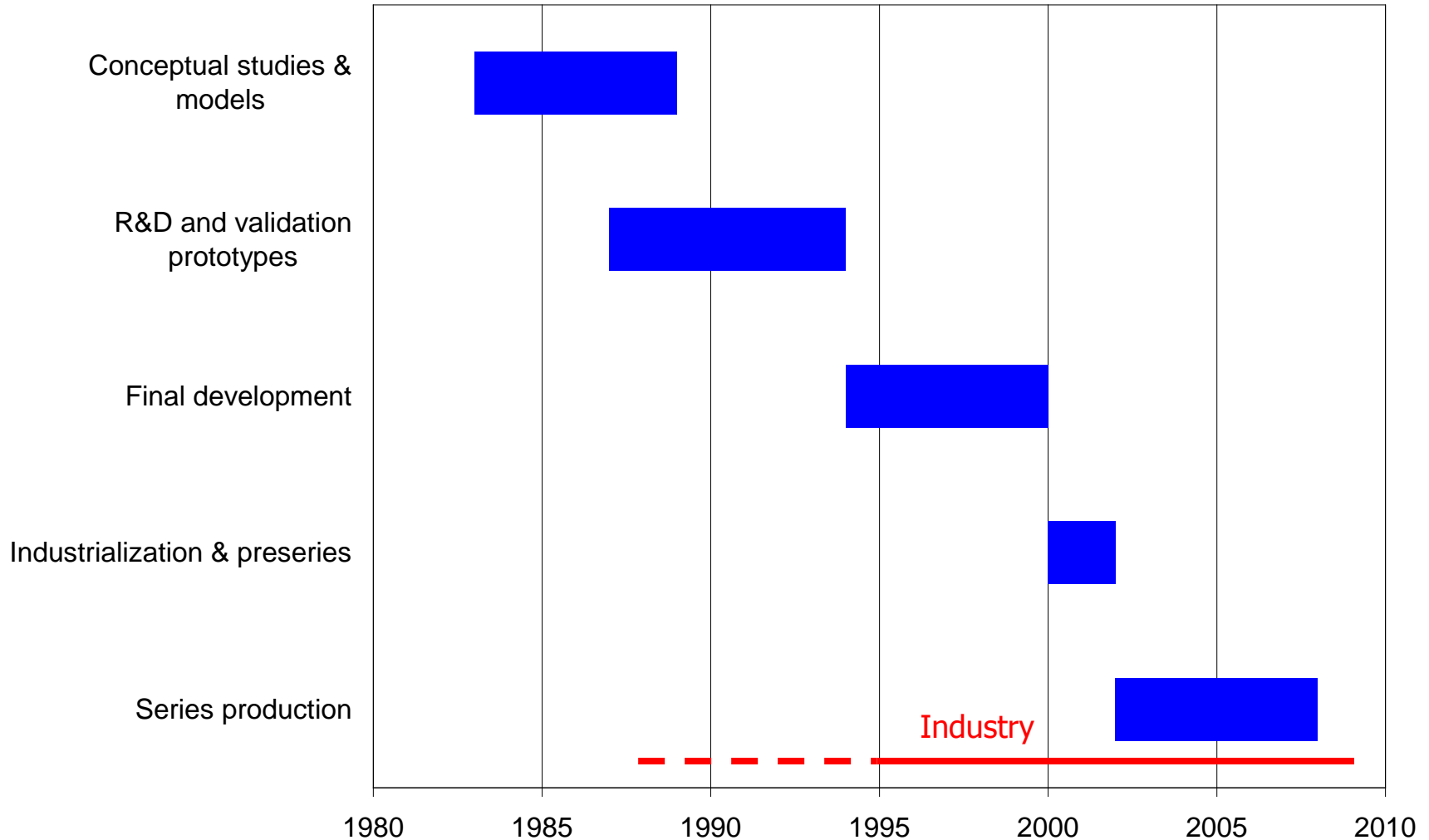

# Industrialization & production ramp-up LHC superconducting dipole magnets

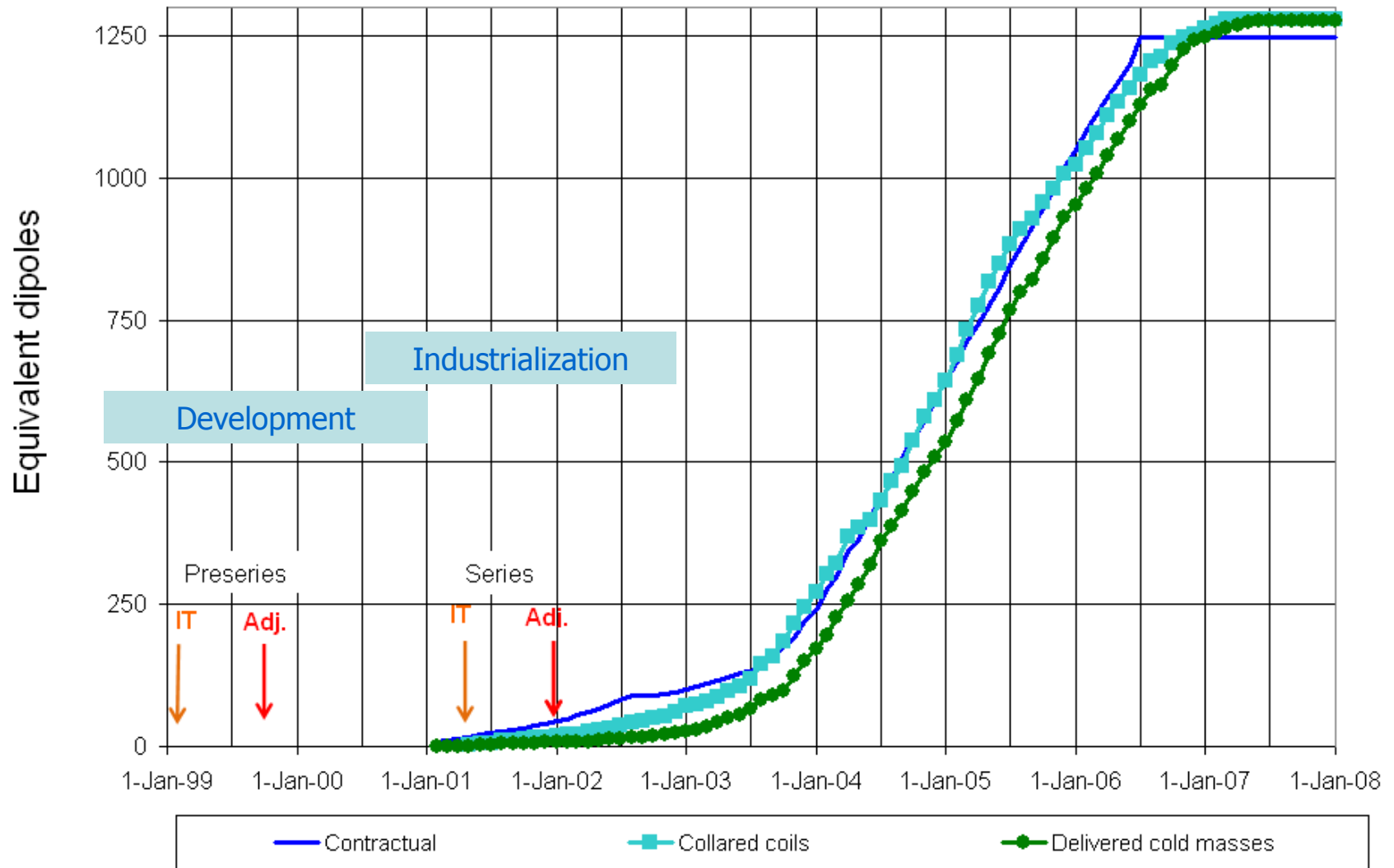

# Buffer storage vs just-in-time delivery

## Restores production flexibility, allows sorting, reduces dispersion

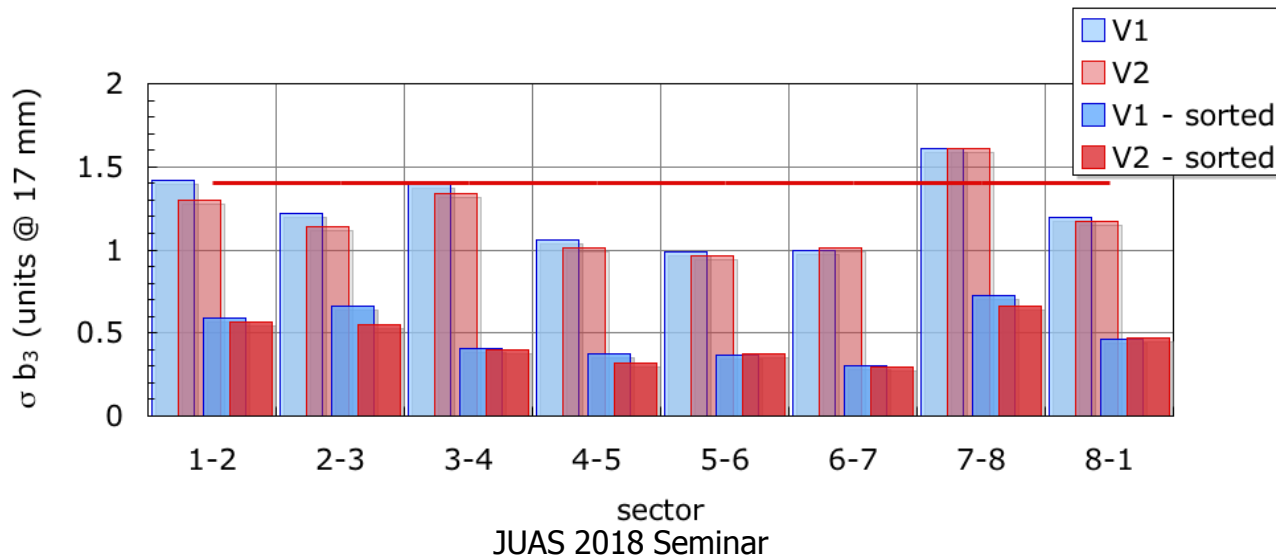
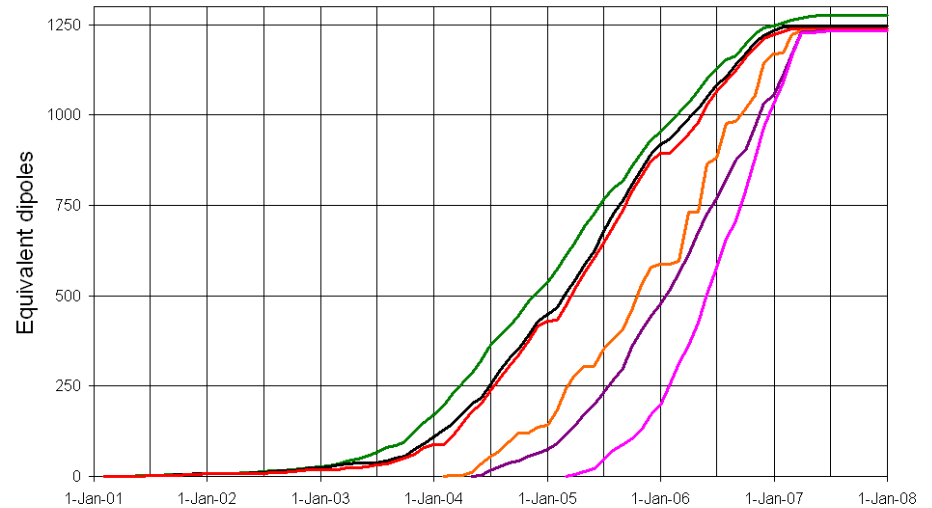



## Contracting and manufacturing

- Technical specification
  - Principle: *do not push to industry risks which they are not in a position to assess*
  - Functional & interface vs build-to-print specification
  - Definition & ownership of specialized tooling
  - Use of performance incentives
- Single or multiple-sourcing
  - Leverage on security of supply and balanced returns in Member States
  - Need for additional production and QA follow-up
  - Intermediate supplies
- Engineering data management
  - Making sure everyone works on the same project
  - Maintaining technical memory in time
- Enforcing QA
  - Documents and procedures
  - Inspections and audits
  - Tests
- Managing the production ramp-up
  - Lead times and conditions for ramp-up
  - Just-in-time vs. production buffers
- **Recovering from industrial difficulties**

# Recovering from industrial difficulties

## Internalization of SSS assembly after insolvency of contractor

- Recovery of specialized tooling from insolvent contractor
- Recovery of component supply contracts from subcontractors
- Installation of new assembly workshop at CERN
- Staffing by industrial support contract



# Recovering from industrial difficulties

## Repair & reinstallation by CERN of cryogenic ring line sectors

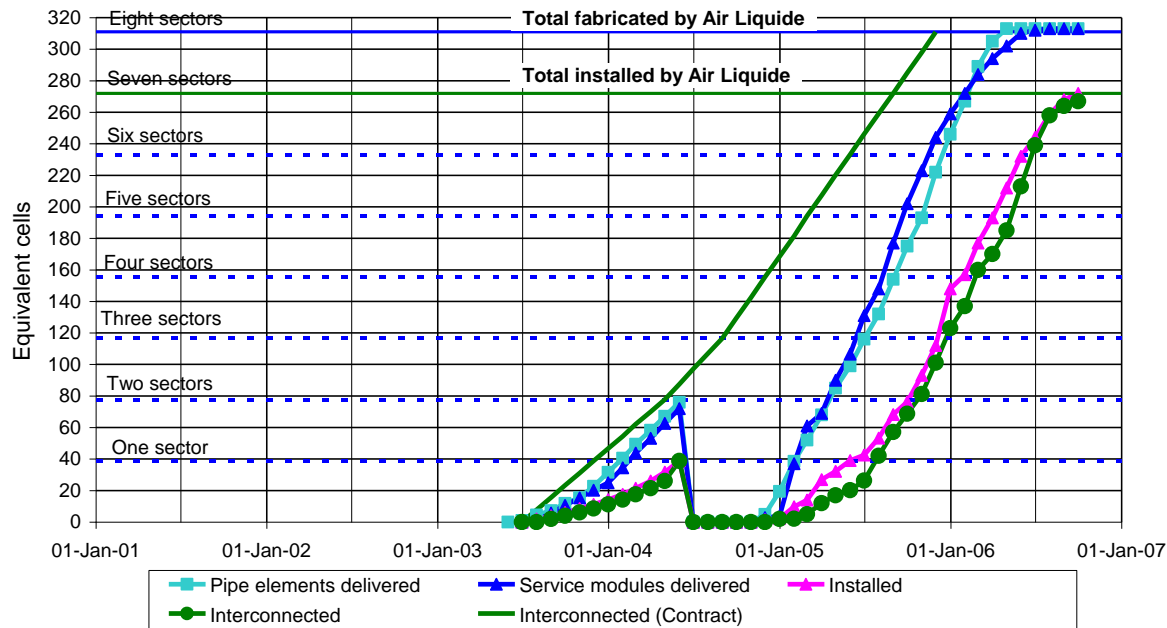
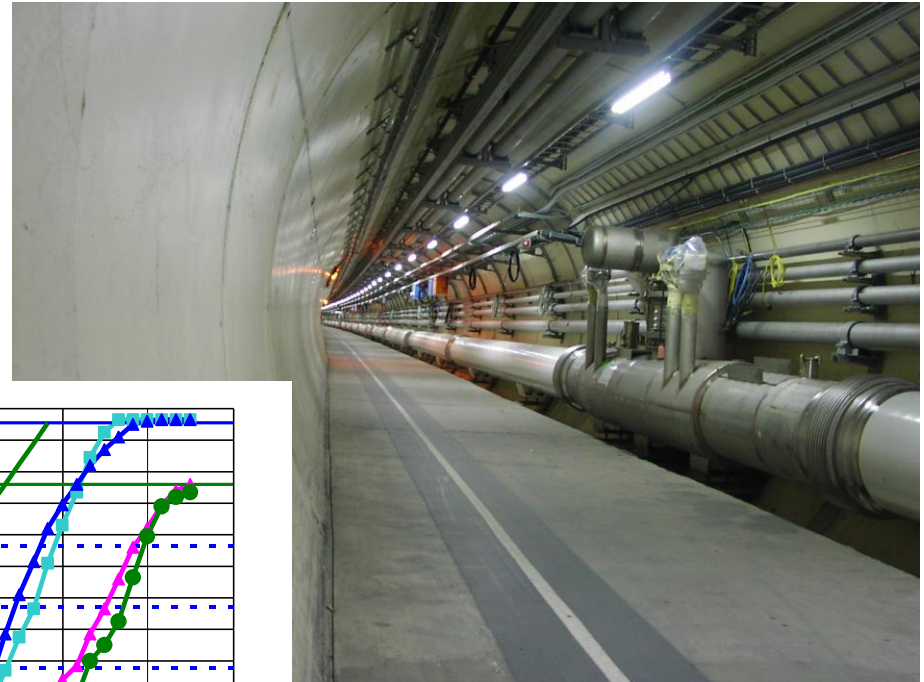
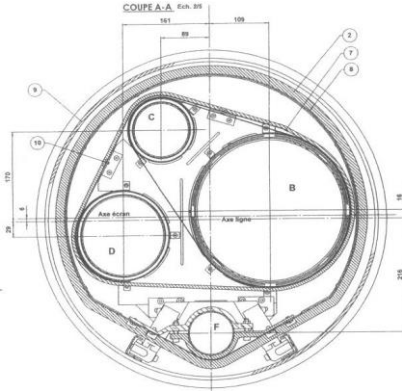

- Large scientific instruments such as particle accelerators demand massive investment of human and material resources and unprecedented level of organization, making them *industrial-size global projects in advanced technology*
- Managing *technological risk* requires striking a delicate balance between adoption of state-of-the-art solutions and introduction of emerging alternatives
- *Cooperation with industry* is essential from early stages of the project in order to achieve success within business constraints
  - Develop and maintain interest in a one-of, technically risky supply
  - Series production of innovative items at market prices
  - Competition with other products/markets
  - Quality and performance through shared incentives
- Completion of *product development and industrialization* is an absolute prerequisite for production ramp-up in industry
- Achieving *quality throughout the project* requires the establishment and enforcement of a comprehensive QAP
  - Configuration management, engineering data management
  - Manufacturing and test plan
  - Inspection
- Maintaining *sufficient resources in the home laboratory* is necessary to cope with
  - tasks outside the interest and capabilities of industry
  - unexpected technical or commercial difficulties
- Conversely, industrial competencies and production capacities developed for the LHC constitute a *comparative advantage* for the suppliers, who can later apply them to other large-scale technological projects

## Two useful references

