



# WP15.4: Doubling the Frascati INFN Beam Test Facility (BTF)

Bruno Buonomo<sup>1</sup>, Luca Foggetta<sup>1</sup>, Claudio Di Giulio<sup>1</sup>, Paolo Valente<sup>2</sup>



1 *INFN Laboratori Nazionali di Frascati*  
2 *INFN Sezione di Roma*

# BTF in the DAΦNE

*The BTF (Beam Test Facility) is part of the DAΦNE accelerator complex:*

*it is composed of a transfer line driven by a pulsed magnet allowing the diversion of electrons or positrons*

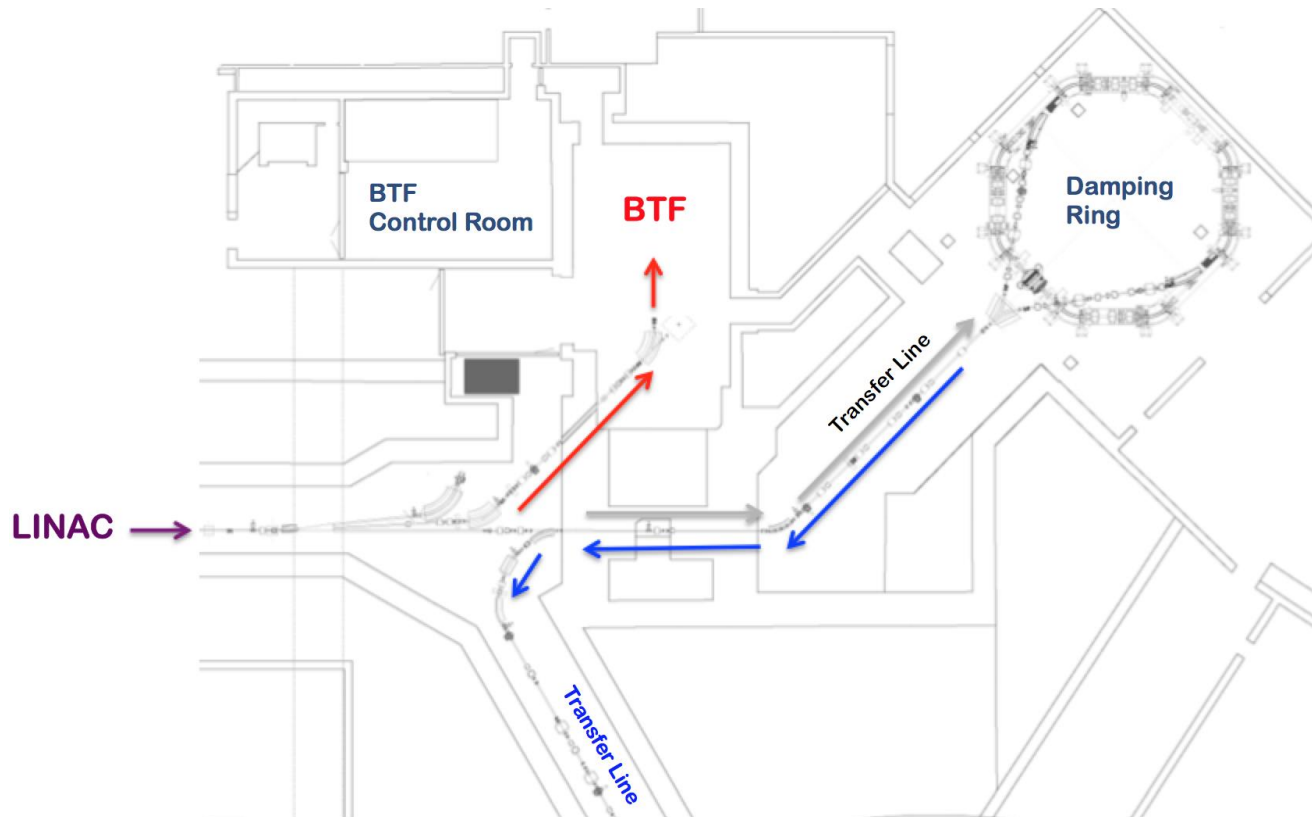

# LINAC

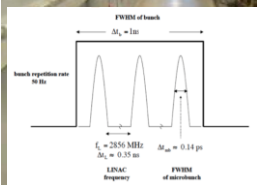
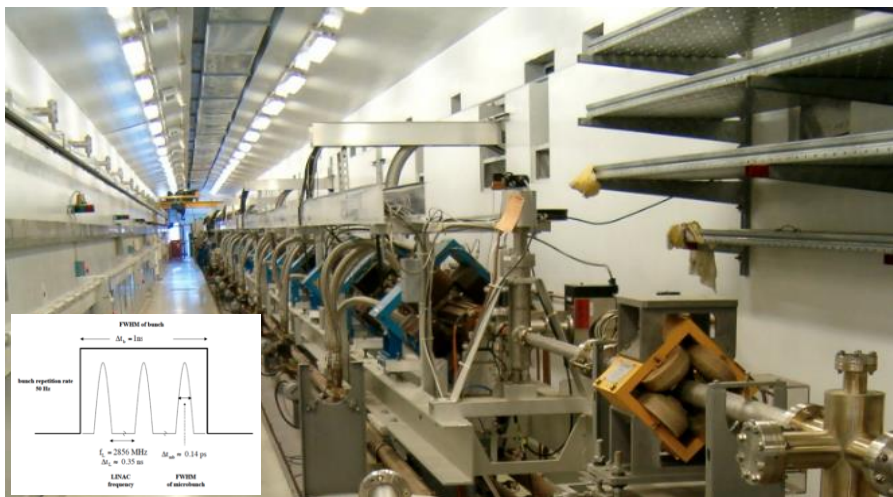

## TITAN Beta (Ca,USA) 1995

- S band LINear Accelerator ~60 m long
- Thermoionic gun, 4x45 MW klystrons
- SLED 15 waveguide  $2/3\pi$  SLAC type section 3m long.

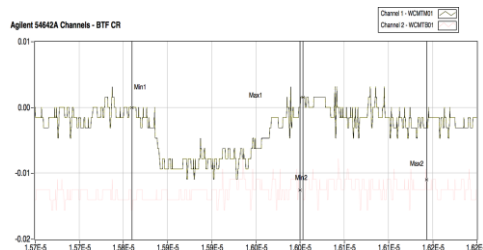
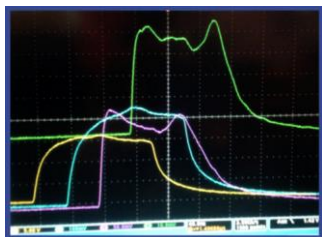

Upgrade pulse width: ~ 150 ns

	Design	Operational
Electron beam final energy	800 MeV	510 MeV
Positron beam final energy	550 MeV	510 MeV
RF frequency	2856 MHz	
Positron conversion energy	250 MeV	220 MeV
Beam pulse rep. rate	1 to 50 Hz	1 to 50 Hz
Beam macropulse length	10 nsec	1.4 to 40 nsec
Gun current	8 A	8 A
Beam spot on positron converter	1 mm	1 mm
norm. Emittance (mm. mrad)	1 (electron) 10 (positron)	< 1.5
rms Energy spread	0.5% (electron) 1.0% (positron)	0.5% (electron) 1.0% (positron)
electron current on positron converter	5 A	5.2 A
Max output electron current	>150 mA	500 mA
Max output positron current	36 mA	85 mA
Transport efficiency from capture section to linac end	90%	90%
Accelerating structure	SLAC-type, CG, $2\pi/3$	
RF source	4 x 45 MWp sledded klystrons TH2128C	

# How the BTF works:

The primary beam collide  $\approx 2x_0$ , Cu produce a secondary beam

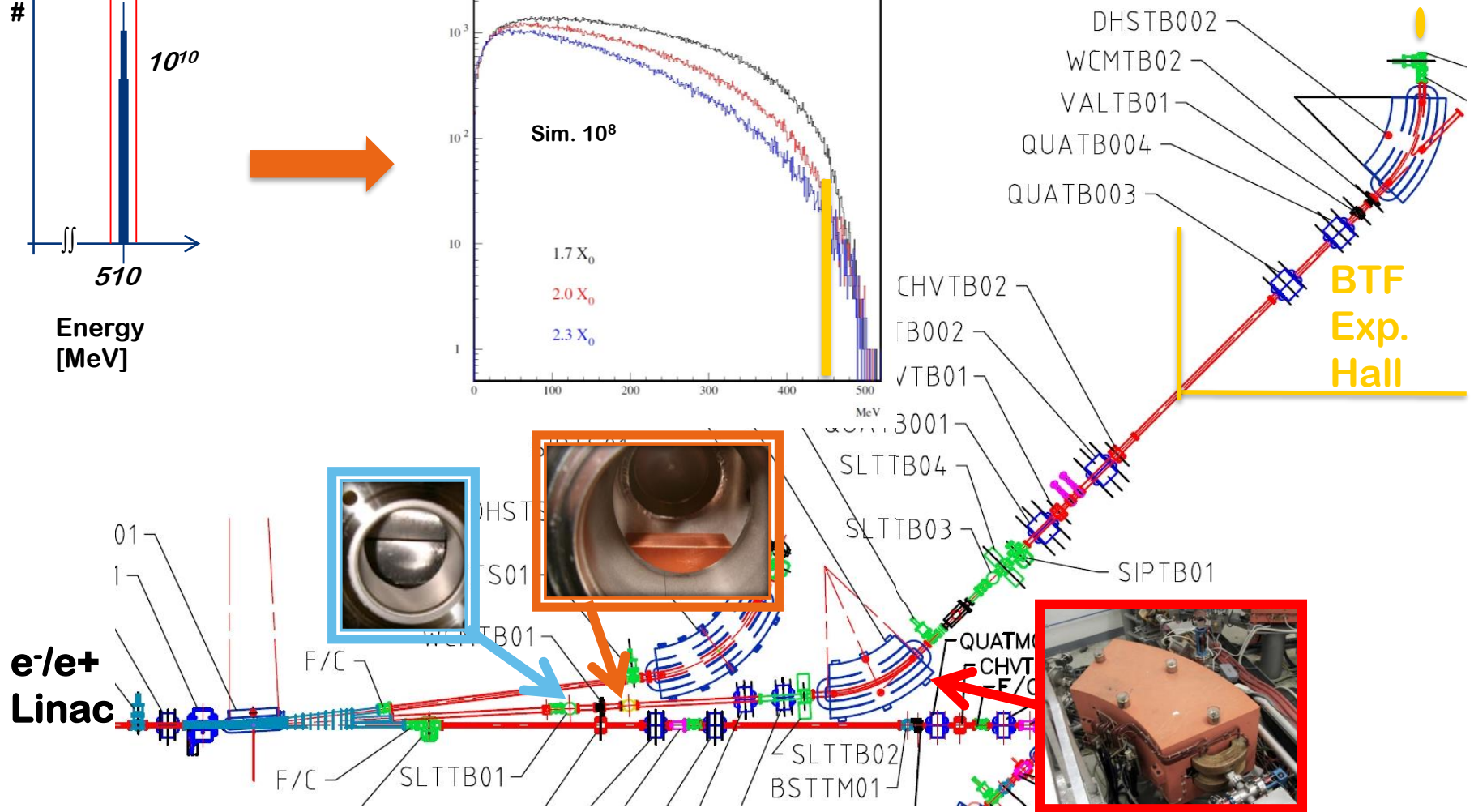
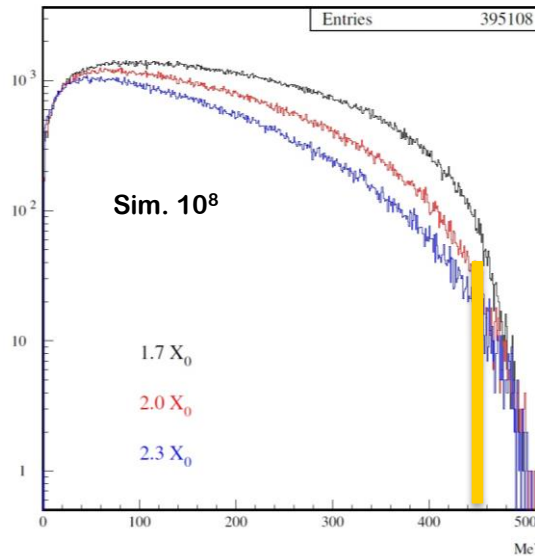
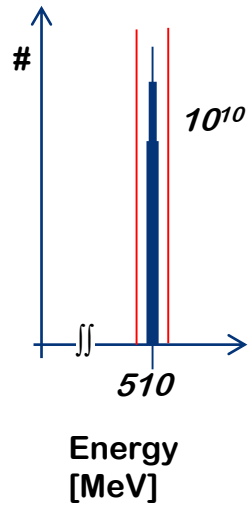

# The Beam-Test Facility



- The users in BTF are able to know in **real time** the beam parameter (type of particle, energy, intensity, dimension and position).
- They have the accelerator complex services available for their setup: power supply, network, gas, DAQ, Vacuum staff, cryogenic.
- Usually BTF works in parasitic way respect to DAΦNE collider.

Parametri	Parasitic		Dedicated	
	With Cu target	Without Cu target	With Cu target	Without Cu target
Particle	e <sup>+</sup> or e <sup>-</sup> (User)	e <sup>+</sup> or e <sup>-</sup> (Dafne status)	e <sup>+</sup> or e <sup>-</sup> (User)	
Energy (MeV)	25–500	510	25–700 (e <sup>-</sup> /e <sup>+</sup> )	250–730 (e <sup>-</sup> ) 250–530 (e <sup>+</sup> )
Energy Resolution	1% at 500 MeV	0.5%	0.5%	
Repetition rate (Hz)	Variable from 10 to 49 (DAFNE status)		1–49 (User)	
Pulse length (ns)	10		1.5–40 (150) (User)	
Intensity (particle/bunch)	1–10 <sup>5</sup> (Energy dependence)	10 <sup>7</sup> –1.5 10 <sup>10</sup>	1–10 <sup>5</sup> Energy dependence	10 <sup>3</sup> –3 10 <sup>10</sup>
Max # of partic.	3.125 10 <sup>10</sup> part./s			
Beam size(mm)	0.5–25 (y) × 0.6–55 (x)			
Divergence (mrad)	1–1.5			



# BTF: Low Intensity

## Single particle

- Primary beam attenuated by a **Copper target**
- Energy of Secondary from 500 up to 30MeV
- The multiplicity follow the Poisson distribution and user can select the mean value.
- Positron and electrons independent from the primary beam.

Energy spread measured by(LYSO Calorimeter)

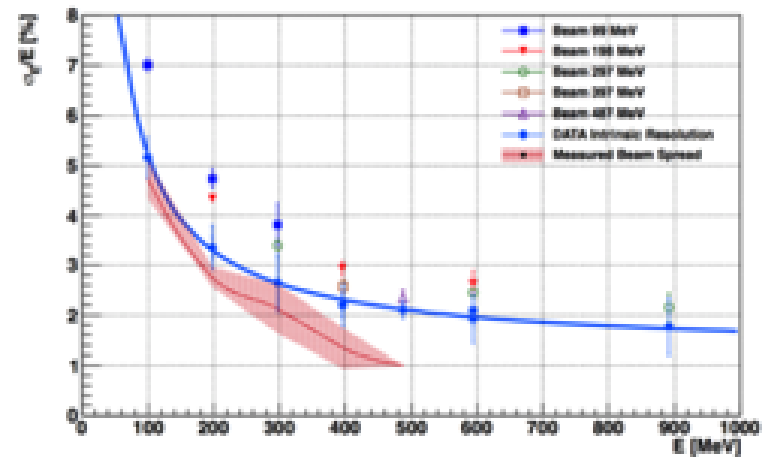

Best beam  
(07/03/2016):  
440x420 $\mu\text{m}^2$

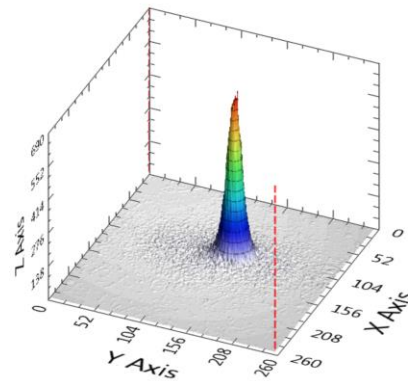
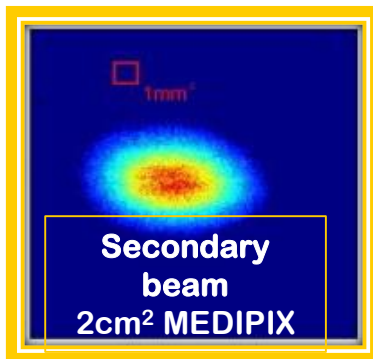

Setting@400MeV

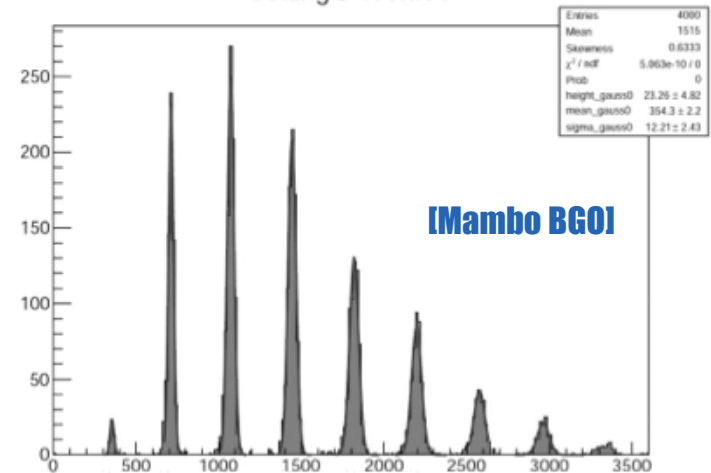

# Diagnostics and services

- **Diagnostic:**

- ICT
- Medipix/Fitpix
- Hodoscope
- Silicon Tracker
- Photon tag
- Neutron detectors
- Flags
- Cams
- GEM
- Calorimeters

- **Services:**

- 4 gas line
- Water, air, HV, network.
- Remote controlled table(step up to 100 $\mu$ m, weight up to 200 Kg)
- LNF mechanical support
- DAFNE operator support
- DAFNE technician support





# Why doubling the BTF:

We open 2 calls every year for experiments and tests beam and we need to reject about 50% of the requested beam time.

For the next years we want provide an hall for experiments that require irradiation test or long beam time, as for example the PADME experiment for the dark sector research.

And the new experimental hall where low intensity (up to  $10^6$  e<sup>-</sup>) test beam on R&D detector beam time will be available.

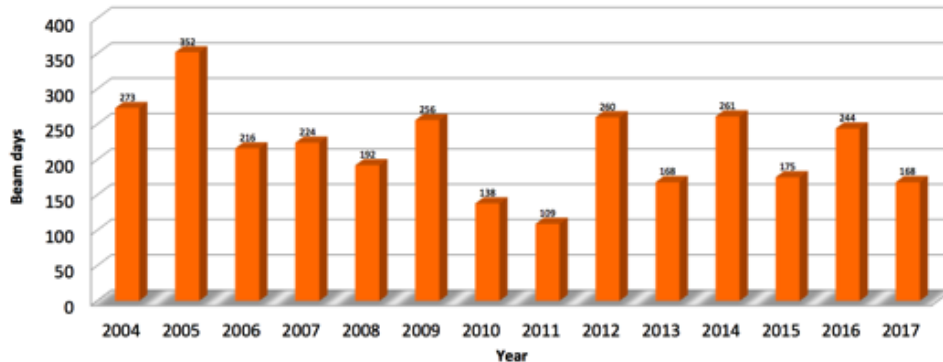

- ✗ Average of 200 beam days/year, 25-30 experimental groups, 150-200 users
- ✗ Undergoing a **major upgrade** in 2018:
  - ✗ Split beam-line for serving two experimental areas
  - ✗ Shielding of second hall
  - ✗ LINAC consolidation
  - ✗ New control room

# CDR in 2016

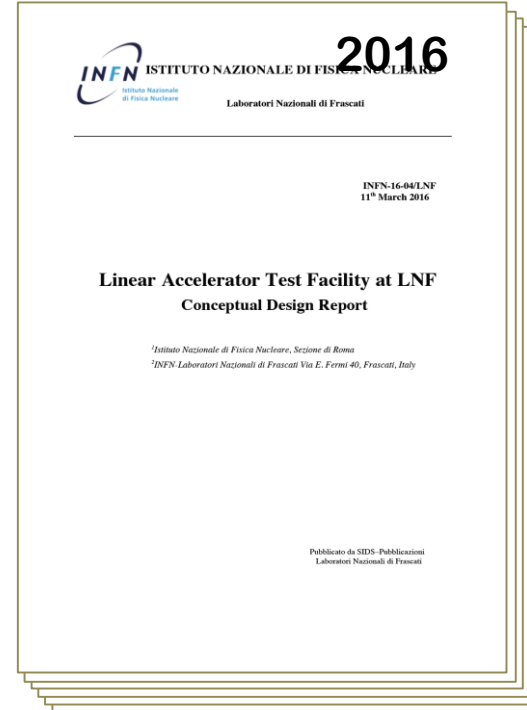
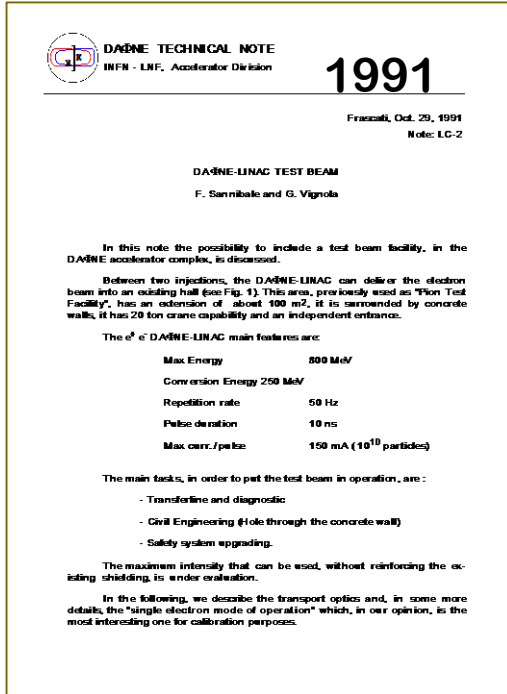

## The BTF staff and upgrade team

Paolo Valente – Roma

Bruno Buonomo, Claudio Di Giulio, Luca Foggetta, David Alesini,

Maurizio Belli, Simone Bini, Bruno Bolli, Sergio Cantarella, Riccardo Ceccareli, Alberto Cecchinelli, Oreste Cerafoli, Renato Clementi, Enrico Di Pasquale, Alessandro Drago, Adolfo Esposito, Oscar Frasciello, Andrea Ghigo, Simona Incremona, Franco Iungo, Stefano Lauciani, Valerio Lollo, Roberto Mascio, Stefano Martelli, Luigi Pellegrino, Graziano Piermarini, Luis Antonio Rossi, Lucia Sabbatini, Claudio Sanelli, Franco Sardone, Giancarlo Sensolini, Serena Strabioli, Ruggero Ricci, Ugo Rotundo, Alessandro Stecchi, Angelo Stella, Raffaele Zarlunga – LNF

# BTF doubling simulations

G4beamline

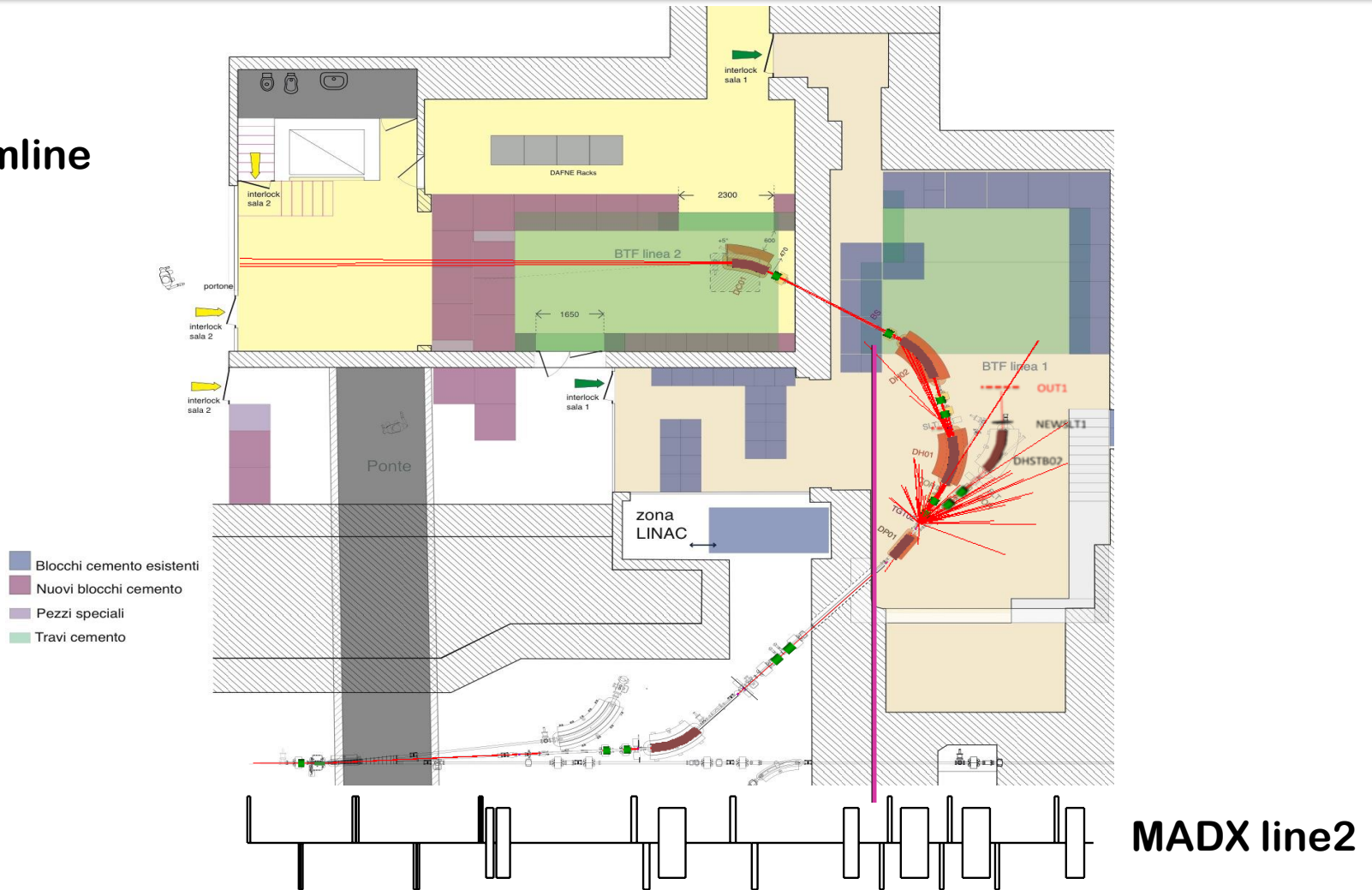

# BTF doubling simulations



## MADX

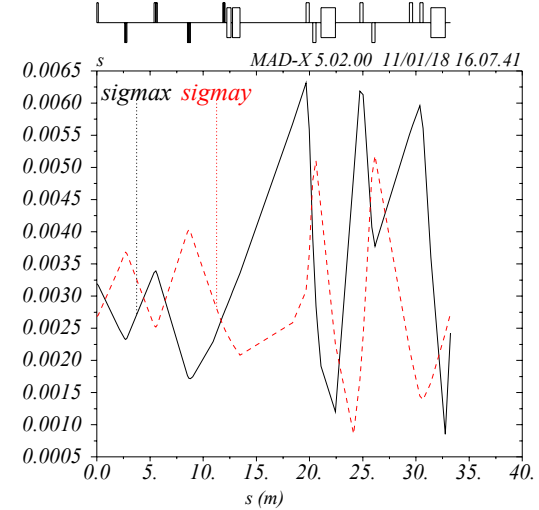
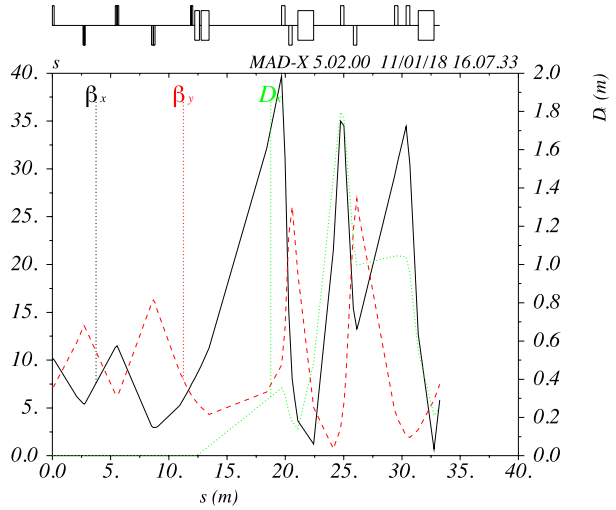

## LINE1

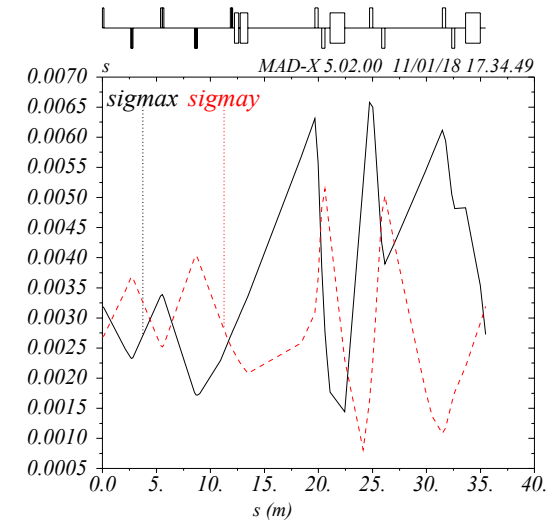
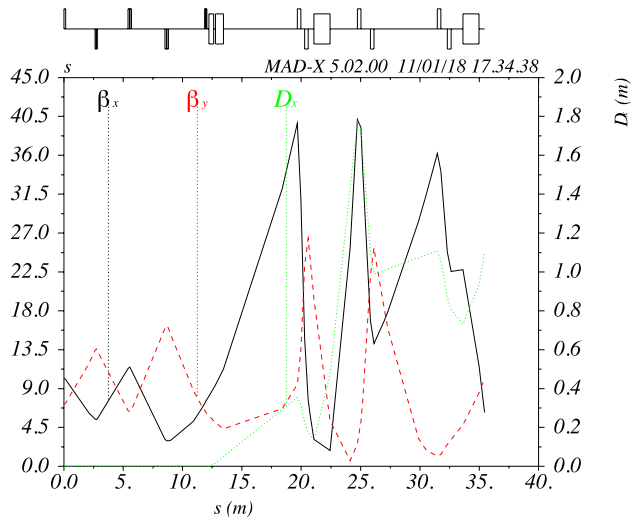

# BTF doubling simulations



## MADX

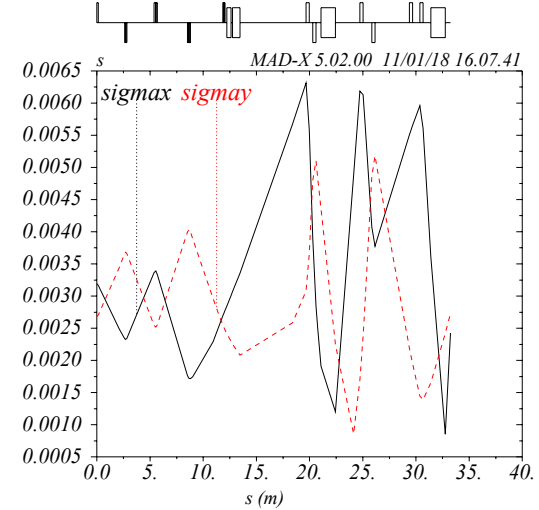
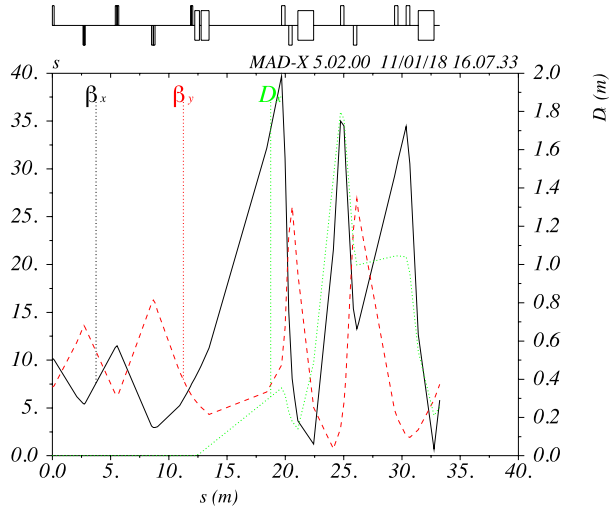

LINE  
OLD

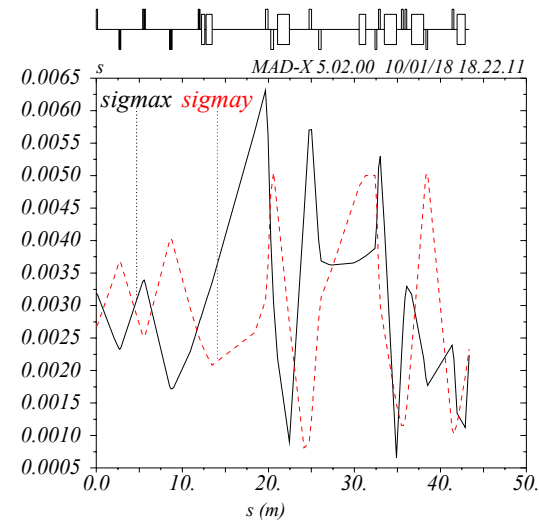
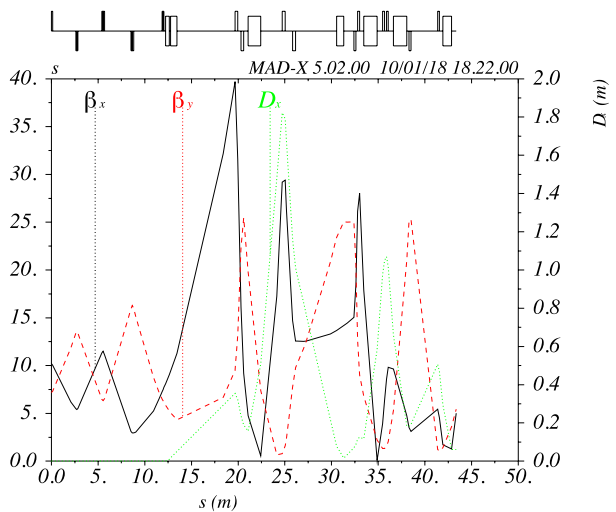

LINE2



# BTF doubling simulations

## Radio Protection Dossier:

- End of 2017: FISMELE Service start to request authorizations to National Institution and Government authority based on the engineering shielding final project.
- Additional diagnostic requested for neutrons and gamma monitoring.
- New search procedure and safety check implemented in the dossier.

Limit for free access area:  $0.1 \mu\text{Sv/h}$ ,  $<10^6/\text{s}$

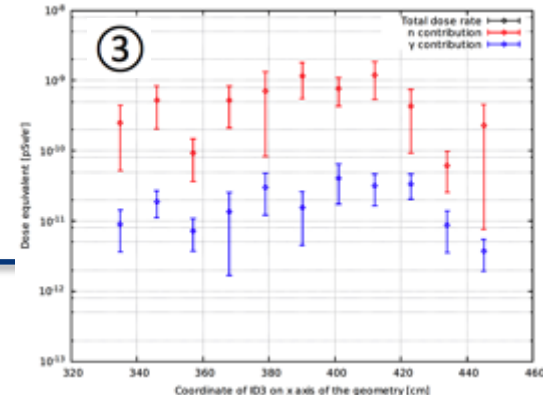
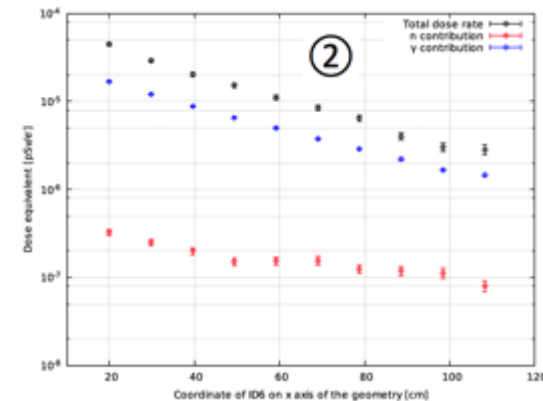
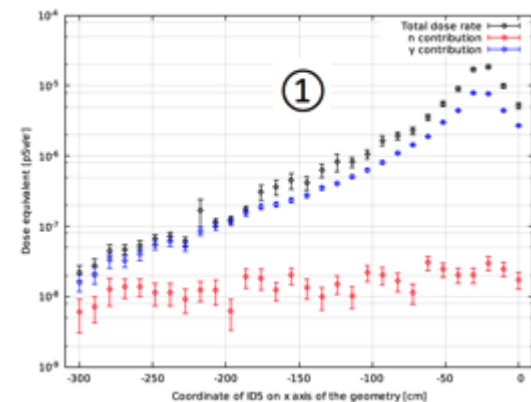
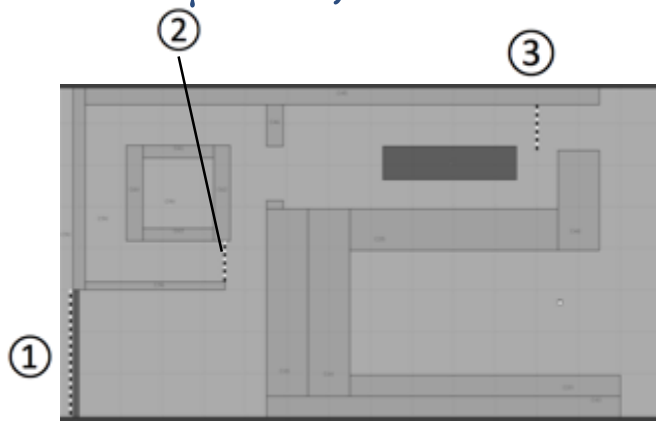
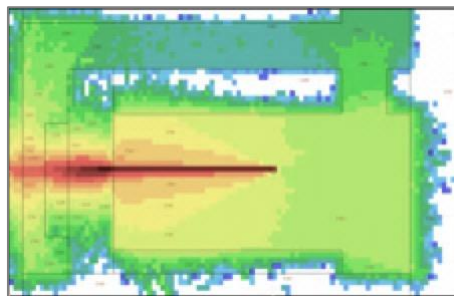

# BTF-2 final layout

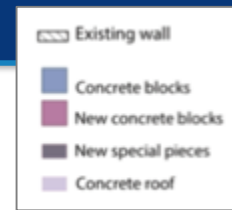

- ① Modified (and removable) staircase to get larger access space from the front of new hall
- ② Preserve DAΦNE racks in order to have no interference with SIDDHARTA-2 run
- ③ Enlarged (top) side access for better use of the area and at the same time improve protection of racks area
- ④ Additional labyrinth in place of sliding shielded door on the (bottom) side of new hall for simpler and faster civil engineering
- ⑤ Correctors added for better beam control
- ⑥ Secondary vacuum for new BTF lines, separated from LINAC primary vacuum for safer operation: added pump, modify interlock.

# Final layout: 3D





# New area

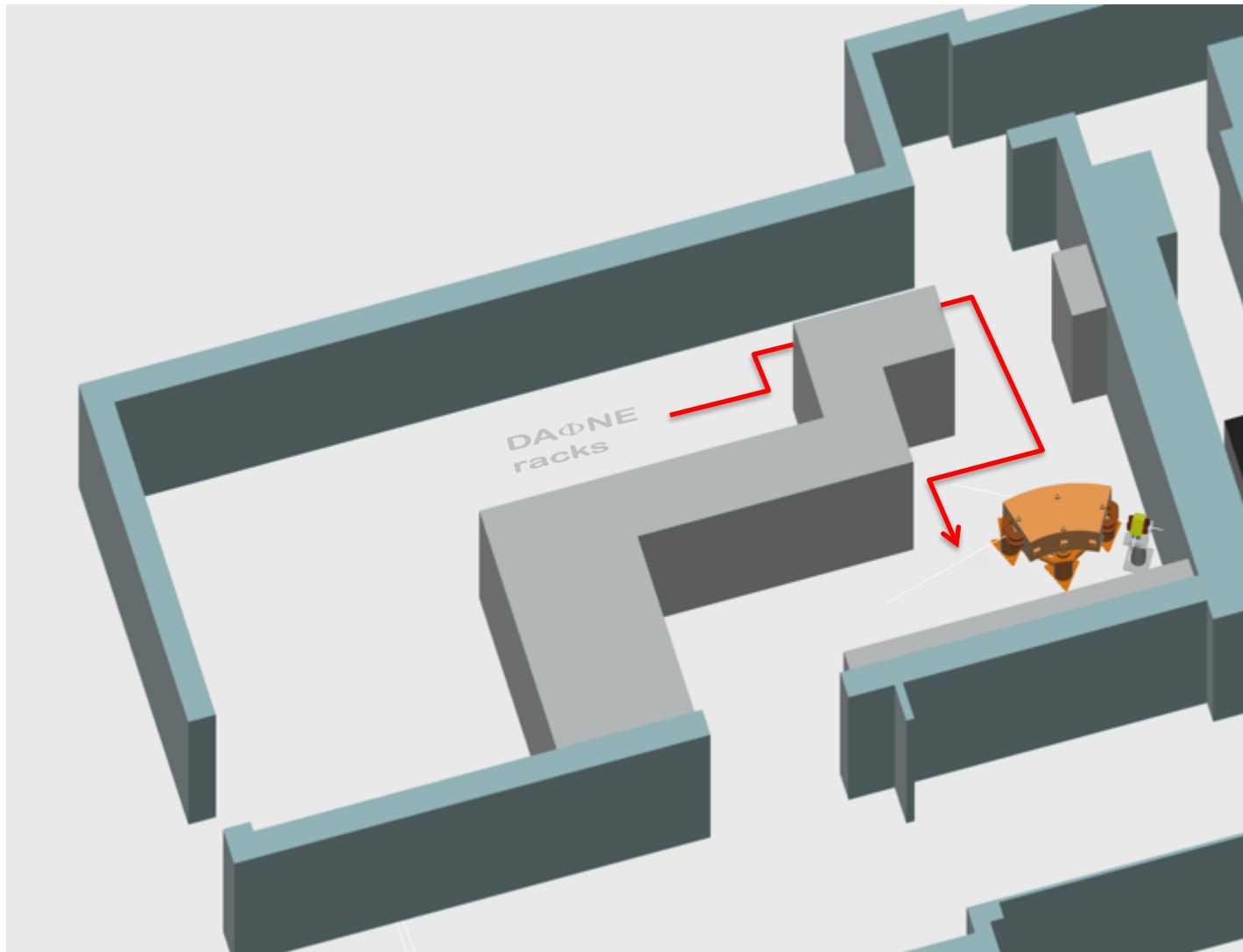

# Civil engineering and shielding (1/5)

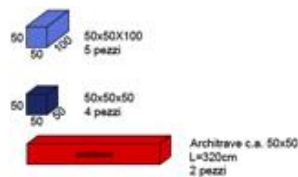
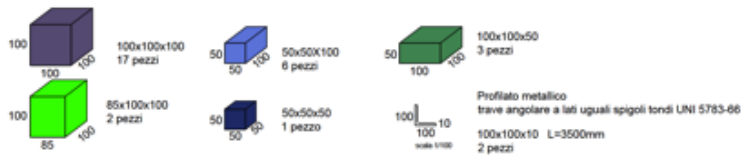
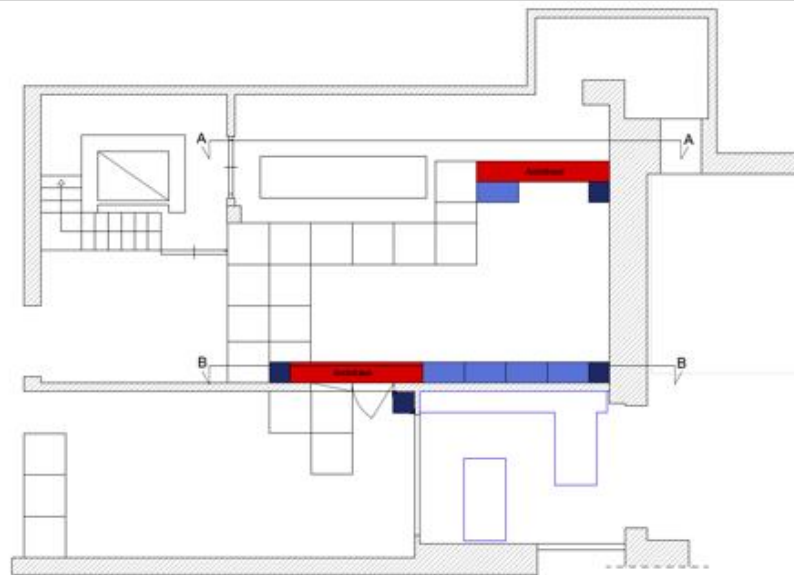
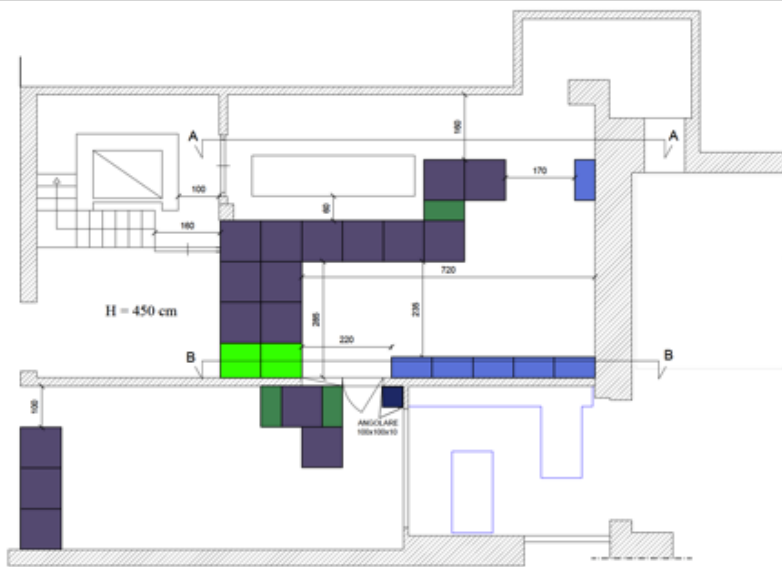

- Radio-protection paper-work **on-going**

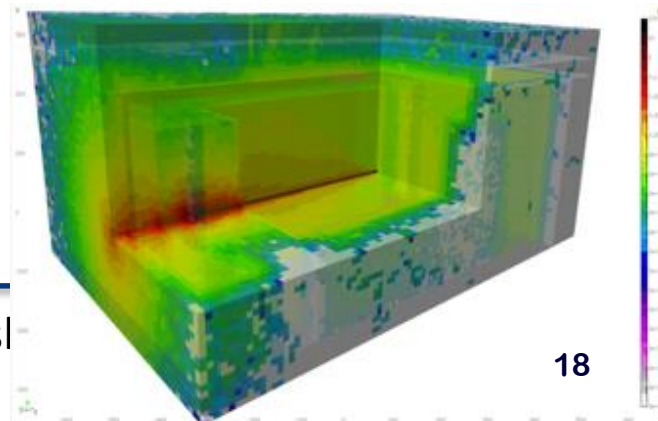

# Civil engineering and shielding (2/5)

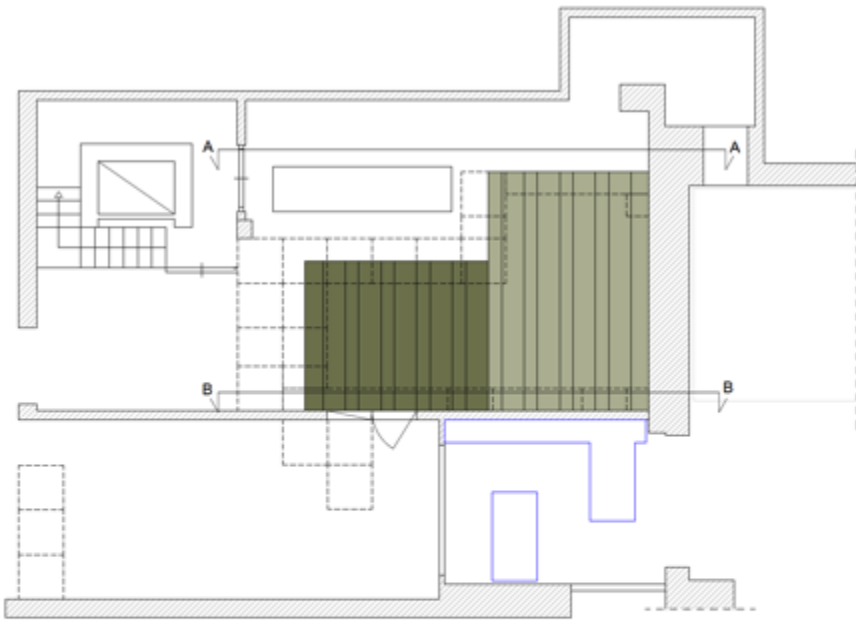

- Trave Tipo A1 L=335cm  
1 pezzo
- Trave Tipo A2 L=335cm  
9 pezzi
- Trave Tipo B2 L=535 cm  
1 pezzo
- Trave Tipo B1 L=535cm  
8 pezzi

- New magnet power supplies: three racks in room upstairs of the (old) control room, path for cables identified **without major intervention**
- Path for additional cooling piping and power cables **in preparation**
- Cooling and power plants modifications **in preparation**
- Final project done, tender **assigned**
- Road consolidation & first demolitions starting in **Dec. 2017**

Sampling



# Civil engineering and shielding (3/5)

Present situation



New layout



# Civil engineering and shielding (4/5)



Shielding blocks area: works finished Jan 2018.



# Civil engineering and shieldings (5/5)



2<sup>nd</sup> floor



1<sup>st</sup> floor

# New magnets

## 13 new magnets:

- Dipoles
- Quadrupoles
- Correctors

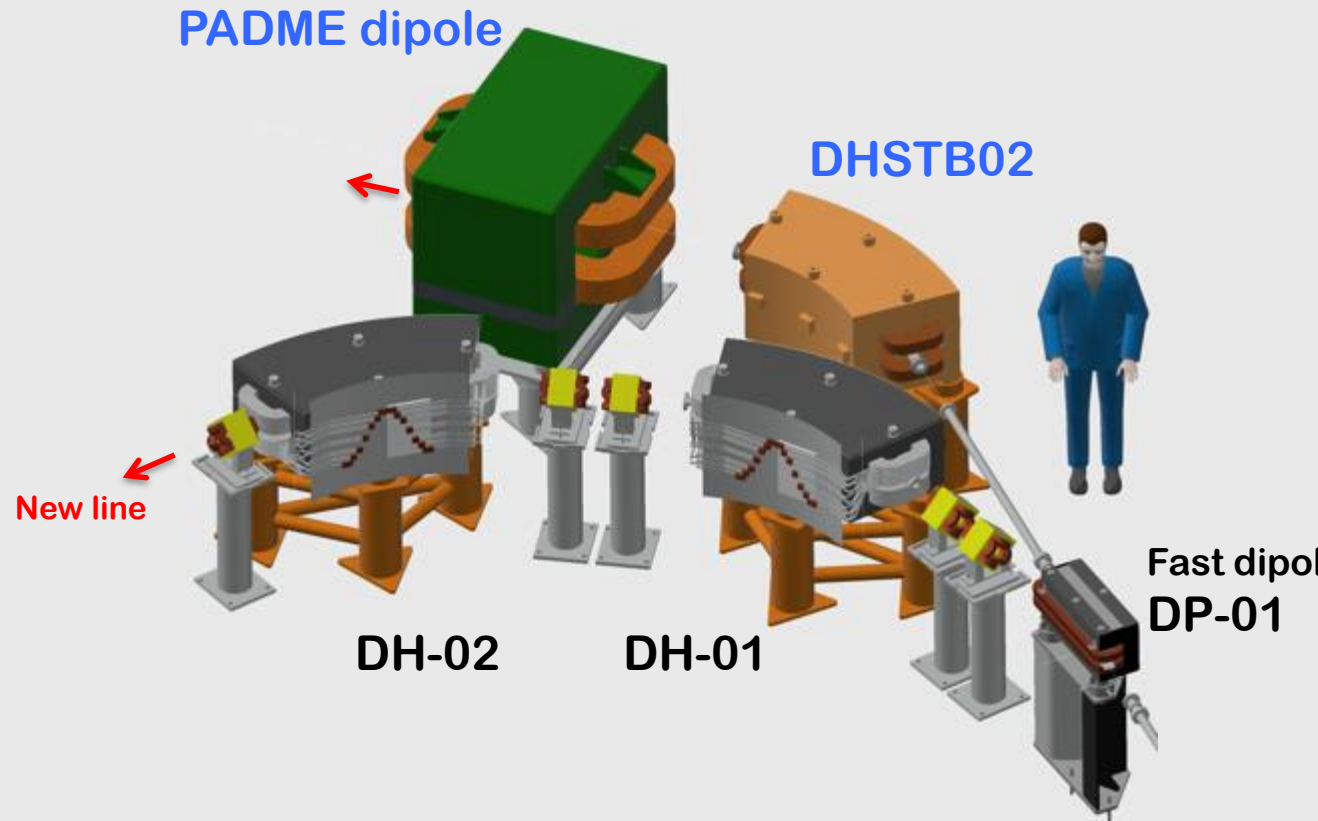

# Magnetic design

## Main constraints

- Fit inside the existing BTF hall for turning by  $135^\circ$  and thus use the former control room as second experimental area
- Split the bending into three dipoles in order to control the dispersion
- Take into account a possible energy upgrade of the LINAC up to 1 GeV: at least 920 MeV secondary beams
  - As a consequence, iron core dipoles working close to saturation

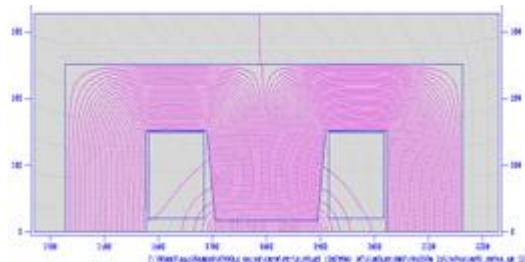
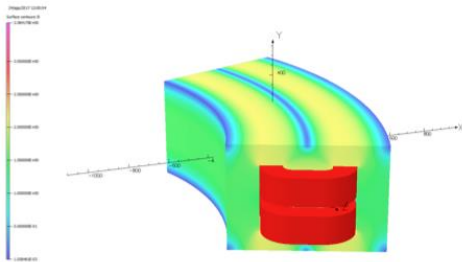

Opera

- Full iron, compact quadrupoles

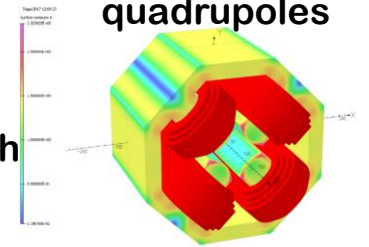

Opera

- Allow the use the parallel of the two lines as much as possible:
  - Be compatible with present DAΦNE operation without linking too much
  - Pulsed dipole for splitting sequence of LINAC pulses
    - Iron lamination dipole, making a relatively small angle ( $15^\circ$ )
    - As compact as possible

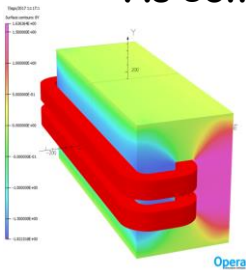

Opera

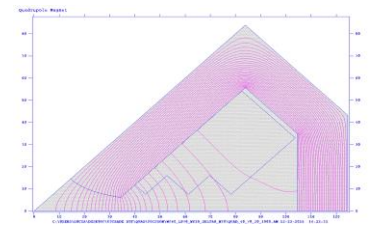
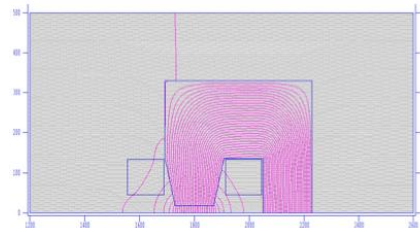



# Pulsed dipole

GENERAL DATA	
Beam energy (MeV)	1000
Curvature radius (m)	3
Gap (mm)	25
Pole width (mm)	110
Nominal flux density (T)	1,11
Bending angle (deg)	15
N per pole (turns)	36
Ampere-turns/pole	11052
Yoke Width (mm)	277
Yoke Height (mm)	359
Yoke Length (mm)	760
Overall Length (mm)	329
Overall Height (mm)	359
Overall Length (mm)	913
Good Field Region (mm)	±25
Field quality ( $\Delta B/B$ )	6,4E-03
Integrated Field quality ( $\Delta I B/I B$ )	2,3E-03
Total weight (kg)	516
ELECTRICAL INTERFACE	
Conductor dimension	7x7 $\varnothing 4$
Nominal Current (A)	316
Nominal Resistive Voltage (V)	113
Rtot ( $\Omega$ )	0,078
Nominal inductance (H)	0,029
Nominal Power (kVA)	35
Maximum Line Cable lenght (m)	20
Proposed cable cross section ( mm <sup>2</sup> )	95
Proposed Output PS Current (A)	330
Proposed Output PS Voltage (V)	130
Proposed Output PS Power (kVA)	42,9
WATER COOLING	
Number of pancakes per pole	3
Number of pancake circuits	6
Number of series circuits	2
$\Delta T$ water ( $^{\circ}C$ )	15
Maximum Water flow (m <sup>3</sup> /s)	0.117
Maximum Water velocity (m/s)	1,55
Maximum $\Delta P$ (bar)	2,94

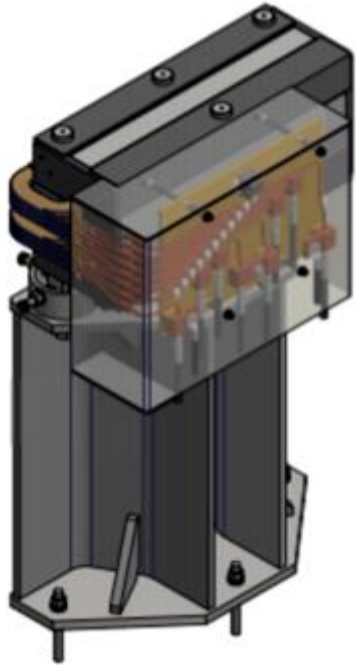

IRON				
V (mm3)	PACK FAC	d (kg/dm3)	Weight (kg)	
6,75E+07		0,96	7,85	509
COILS				
V (mm3)	FILL FAC	d (kg/dm3)	Weight (kg)	
9.46E+06		0,59	8,9	50

## Iron lamination dipole

- Magnetic and electro-thermal design, mechanical drawings **completed**
- Construction **started**
- Power supply specifications and tender **completed**; ramping+stabilization within **≈100 ms**

# DP-01 Timing

- 2 → 3 pulsed magnets
- 50 Hz rep. rate : 20 ms between LINAC pulses
- 1 second divided into two 25+25 pulses sequences
- 1 pulse driven to the spectrometer line for energy measurement (DHPTS01 on)
- During injections, at least 5 pulses go straight into the damping ring (all off)
- The remaining 25-1-n pulses (up to 19) are diverted to the BTF line (DHPTB101 on)
- Start **ramping** the new DP01 dipole at the beginning of the sequence; stabilizes in 100 ms;
- All pulses available for BTF (DHPTB101 on) will be driven to the BTF-2 line

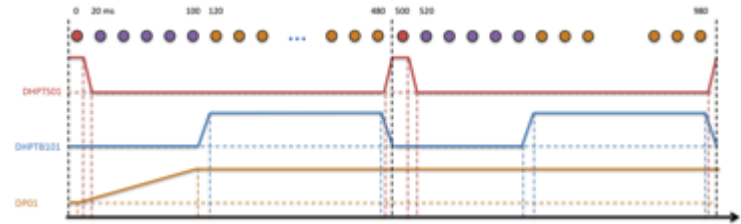
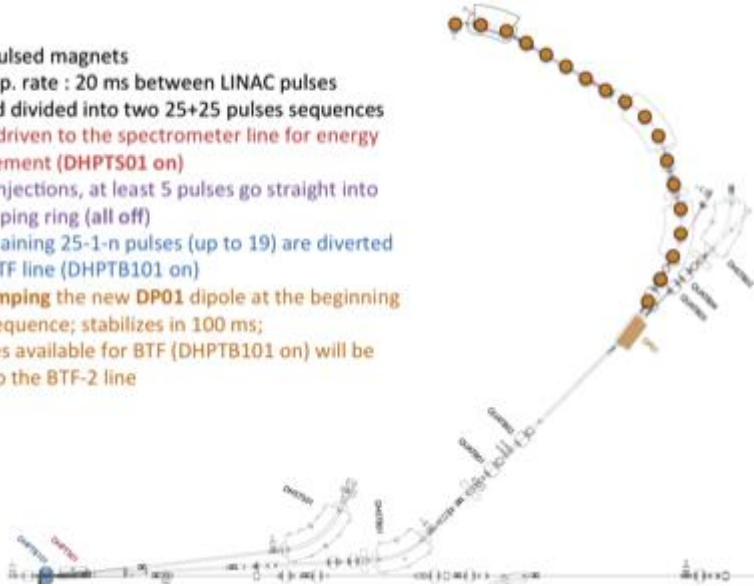

- 2 → 3 pulsed magnets
- 50 Hz rep. rate : 20 ms between LINAC pulses
- 1 second divided into two 25+25 pulses sequences
- 1 pulse driven to the spectrometer line for energy measurement (DHPTS01 on)
- During injections, at least 5 pulses go straight into the damping ring (all off)
- The remaining 25-1-n pulses (up to 19) are diverted to the BTF line (DHPTB101 on)
- Start **ramping** the new DP01 dipole at the beginning of the sequence; stabilizes in 100 ms;
- All pulses available for BTF (DHPTB101 on) will be driven to the BTF-2 line
- Start **ramping down** DP01 at the beginning of a (semi-)sequence; off in <100 ms
- All pulses available for BTF (DHPTB101 on) straight to the BTF-1 line

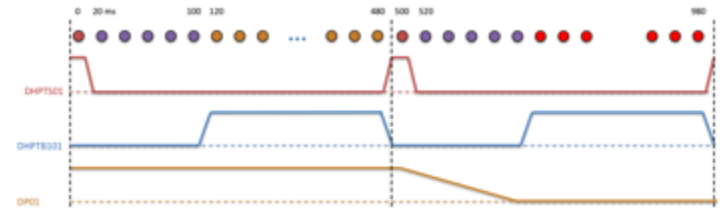
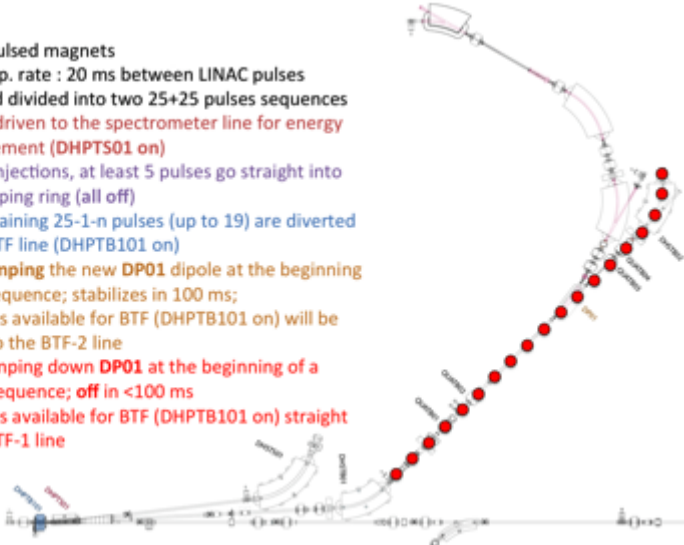

# Pulsed dipole detailed drawings

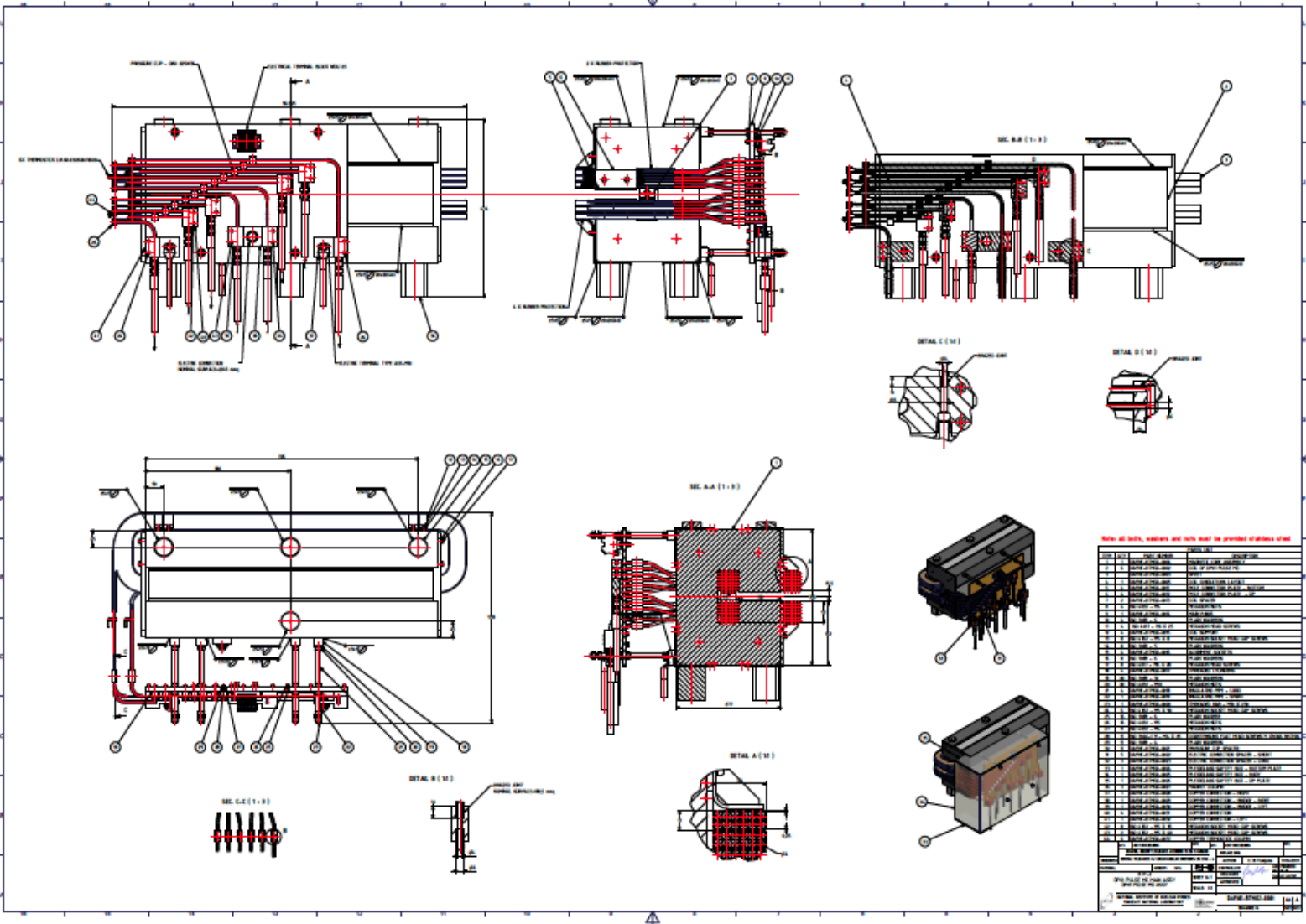

# Pulsed dipole construction

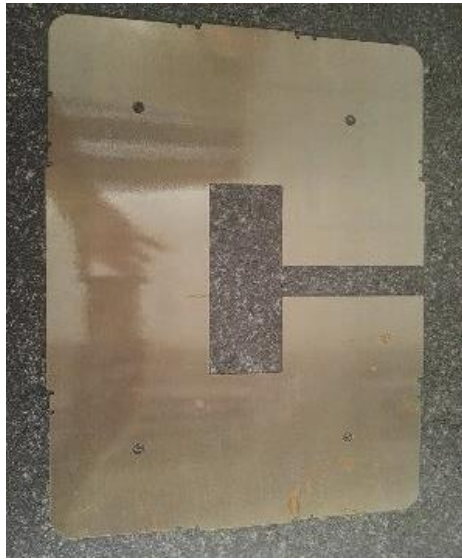

Laser cut

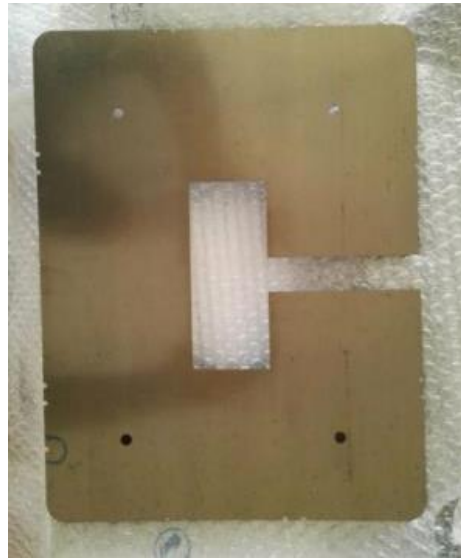

Electron Discharge Machining CMM shape measurement

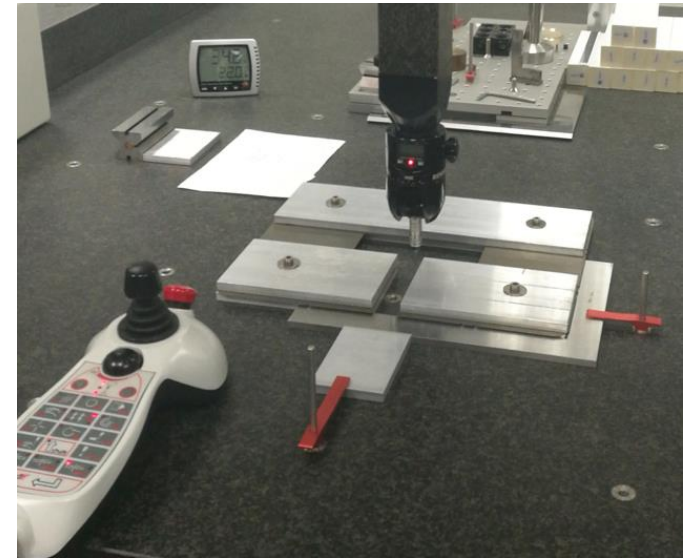

Under evaluation by the metrology service @ LNF

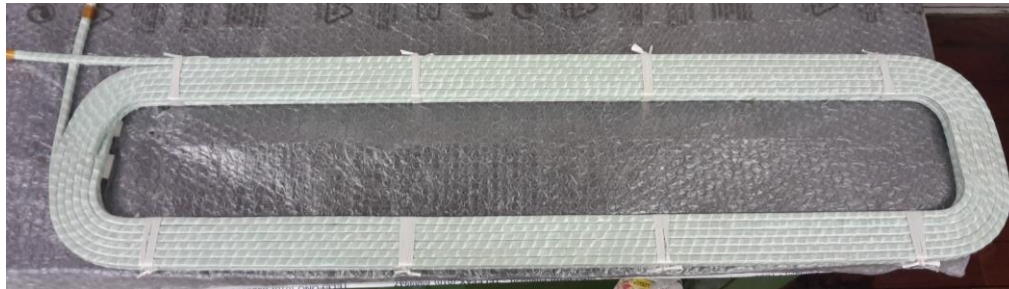

First coil



# New DC dipoles

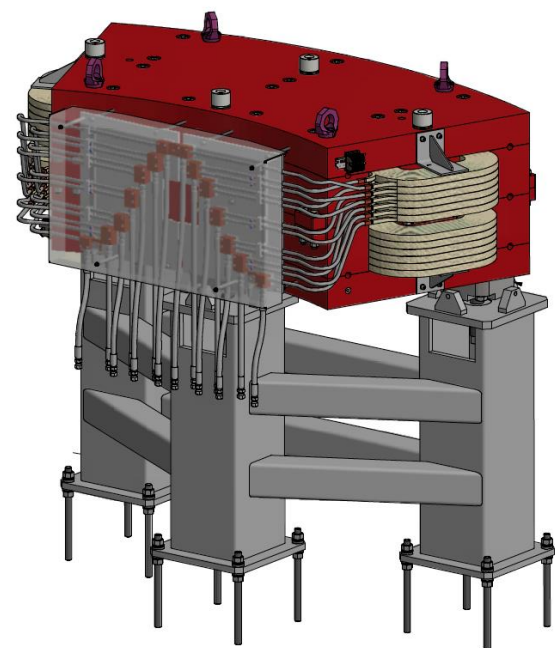

GENERAL DATA	
Beam energy (MeV)	921
Curvature radius (m)	1,8
Gap (mm)	35
Pole width at the gap (mm)	190
Pole width at the yoke (mm)	220
Nominal flux density (T)	1,7056
Bending angle (deg)	45,00
N per pole (turns)	120
Iron Width (mm)	735
Overall Width	780
Overall Height (mm)	503
Overall Length (mm)	1672
Good Field Region (mm)	±15
Field quality ( $\Delta B/B$ )	4,29E-04
Integrated Field quality ( $\Delta IB/IB$ )	3,78E-04
Total weight (kg)	4006
ELECTRICAL INTERFACE	
Conductor dimension	9.5x9.5 $\Phi$ 5.5
Nominal Current (A)	262
Nominal Resistive Voltage (V)	72
Rtot ( $\Omega$ )	0,276
Nominal inductance (H)	0,423
Nominal Voltage on magnet (V) with a 10 s raising time (V)	83
Nominal Power (kVA)	22
Maximum Line Cable length (m)	20
Proposed cable cross section (mm <sup>2</sup> )	95
Proposed Output PS Current (A)	280
Proposed Output PS Voltage (V)	95
Proposed Output PS Power (kVA)	26,6
WATER COOLING	
Number of pancake per pole	6
Number of Turn per pancake	(10 H 2 V)
$\Delta T$ water ( $^{\circ}C$ )	15
Maximum Water flow (m <sup>3</sup> /s)	3,44E-04
Maximum Water velocity (m/s)	1,21
Maximum $\Delta P$ (bar)	3,82

IRON			
V (mm3)	PACK FAC	d (kg/dm3)	Weight (kg)
3,99E+08	1	7,86	3140
COILS			
V (mm3)	FILL FAC	d (kg/dm3)	Weight (kg)
9,5E+07	0,599	8,9	506

## Iron core dipoles

- Magnetic and electro-thermal design, mechanical drawings **completed**
- Power supplies specifications and tender **completed**

# DC dipole detailed drawings

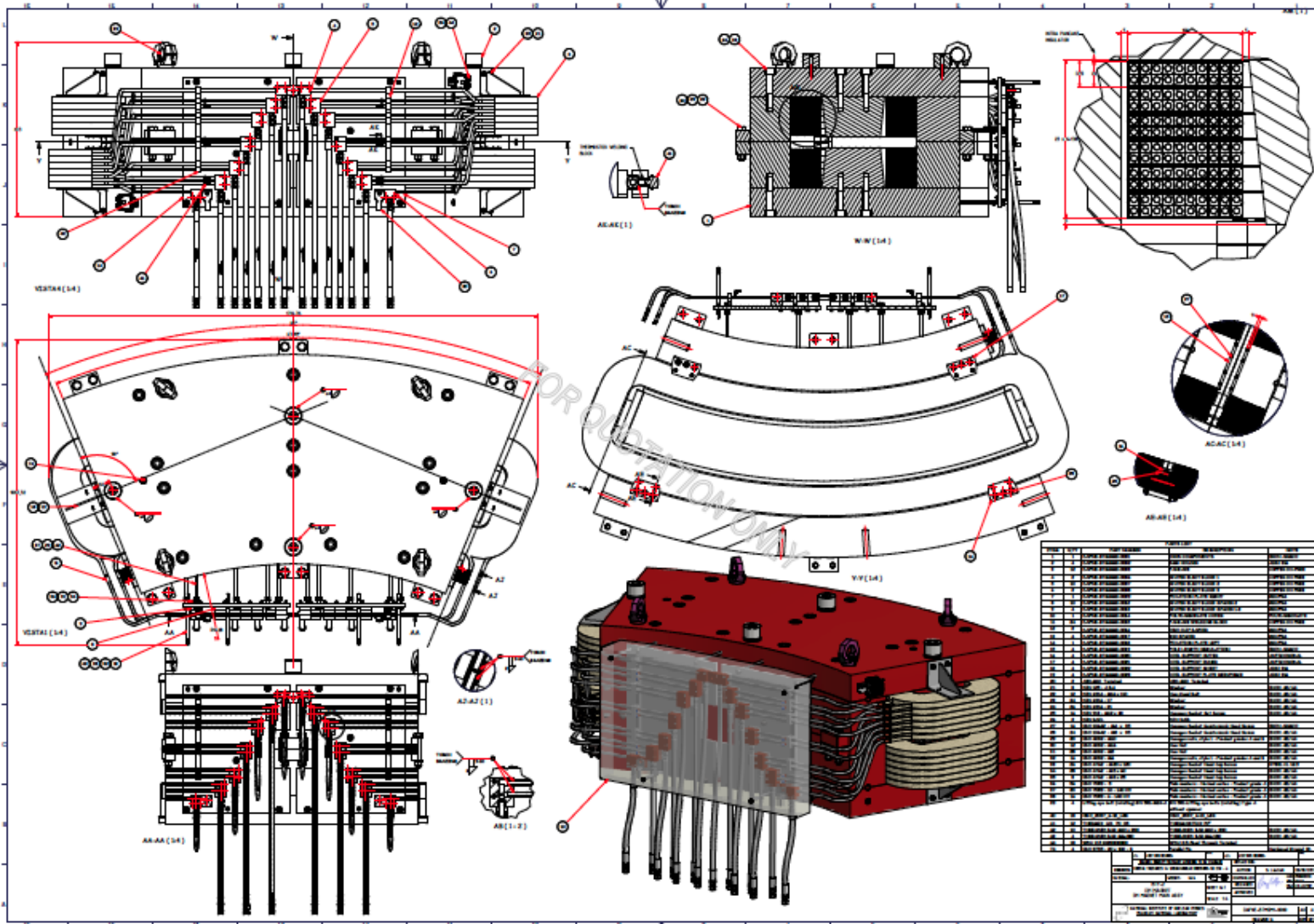

# New quadrupoles

	Unit	Value
<b>MAIN SPECIFICATION</b>		
Nominal Gradient	T/m	20
Bore	mm	45
Magnetic length	mm	200
Pole width	mm	45
Integrated quality (r=15mm)		$5 \cdot 10^{-3}$
<b>COIL DATA</b>		
Conductor dimensions	mm x mm	5x5 bore $\phi$ 3mm
Number of turns per pole		46
Water pressure drop	bar	3.5
<b>ELECTRICAL INTERFACE</b>		
Nominal Current	A	88
Magnet Resistance	m $\Omega$	110
Magnet Inductance	mH	22
Nominal Voltage	V	11
Power	KW	0.97

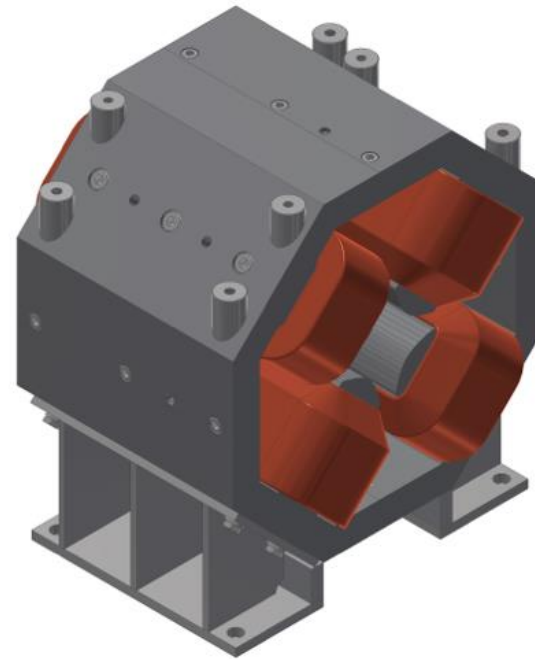

## Iron core quadrupoles

- Magnetic, electro-thermal, design **completed**
- **Detailed mechanical drawings almost completed**
- **Power supplies specifications and tender completed**

# BTF doubling status

- Internal Civil engineering and shielding March 2018.
- Pulsed dipole end of April 2018.
- New line September 2018
- Quadrupoles end of September 2018.
- Human resources: 1FTE up to Nov. 2018



# 15.4 MILESTONES

- **Additional beam line (M34)** (as discussed in November 2017)
- ✓ **Photon tagging upgrade (M70)**

# MS70 Photon tag

- The complete redesign of the BTF facility, including the installation of a second user beam-line, opened the possibility of re-engineering the photon tagging system with the objective of making it again available to the detector development community.
- The system has been re-engineered, the tagging modules configuration revised and the failing or missing readout electronics and PC revamped.
- All components have been installed and tested and are ready to be used in the new C-shaped magnet of the new BTF line.

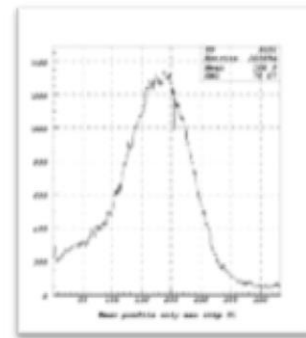
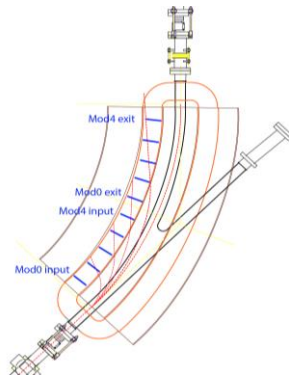
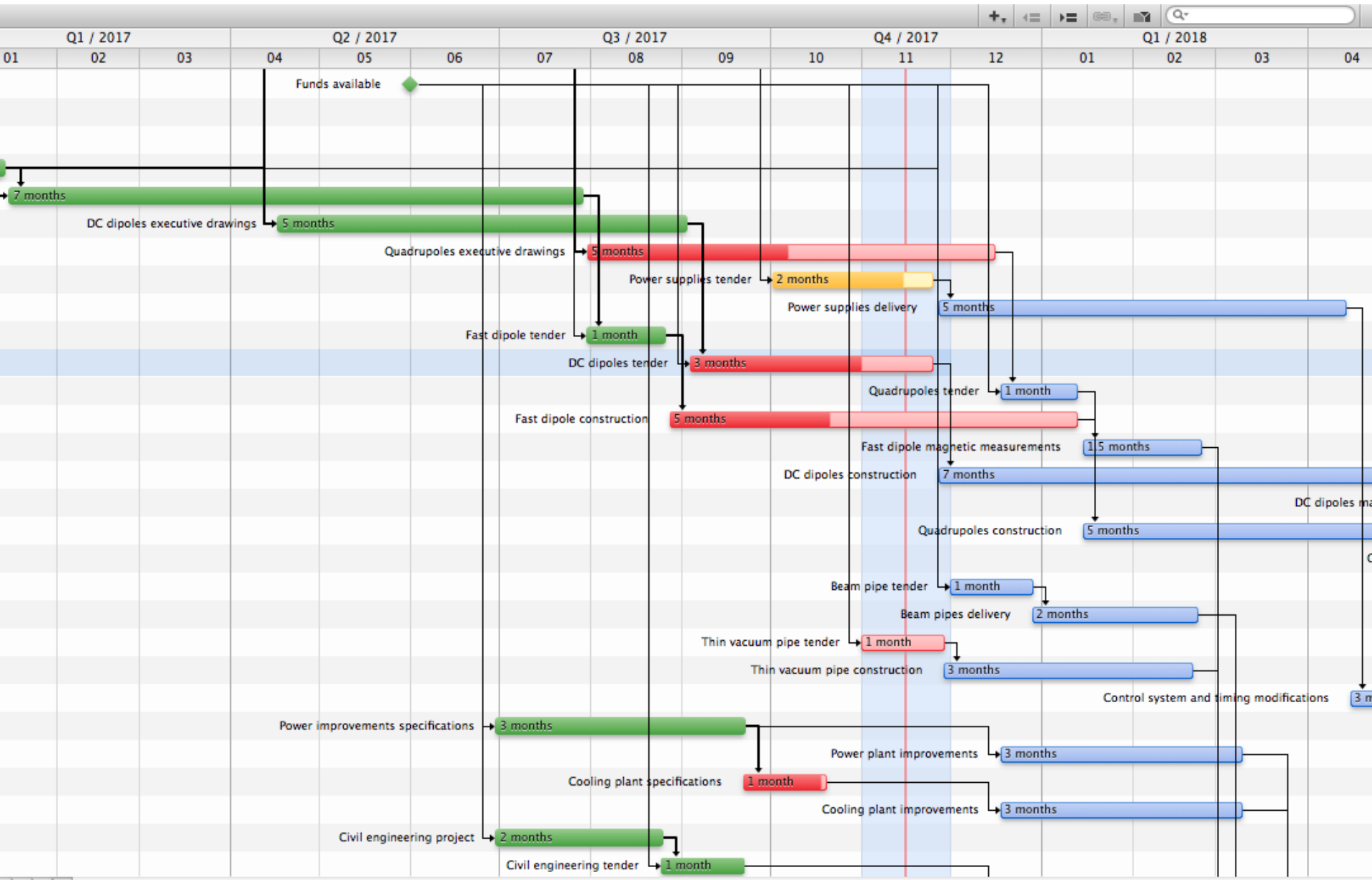
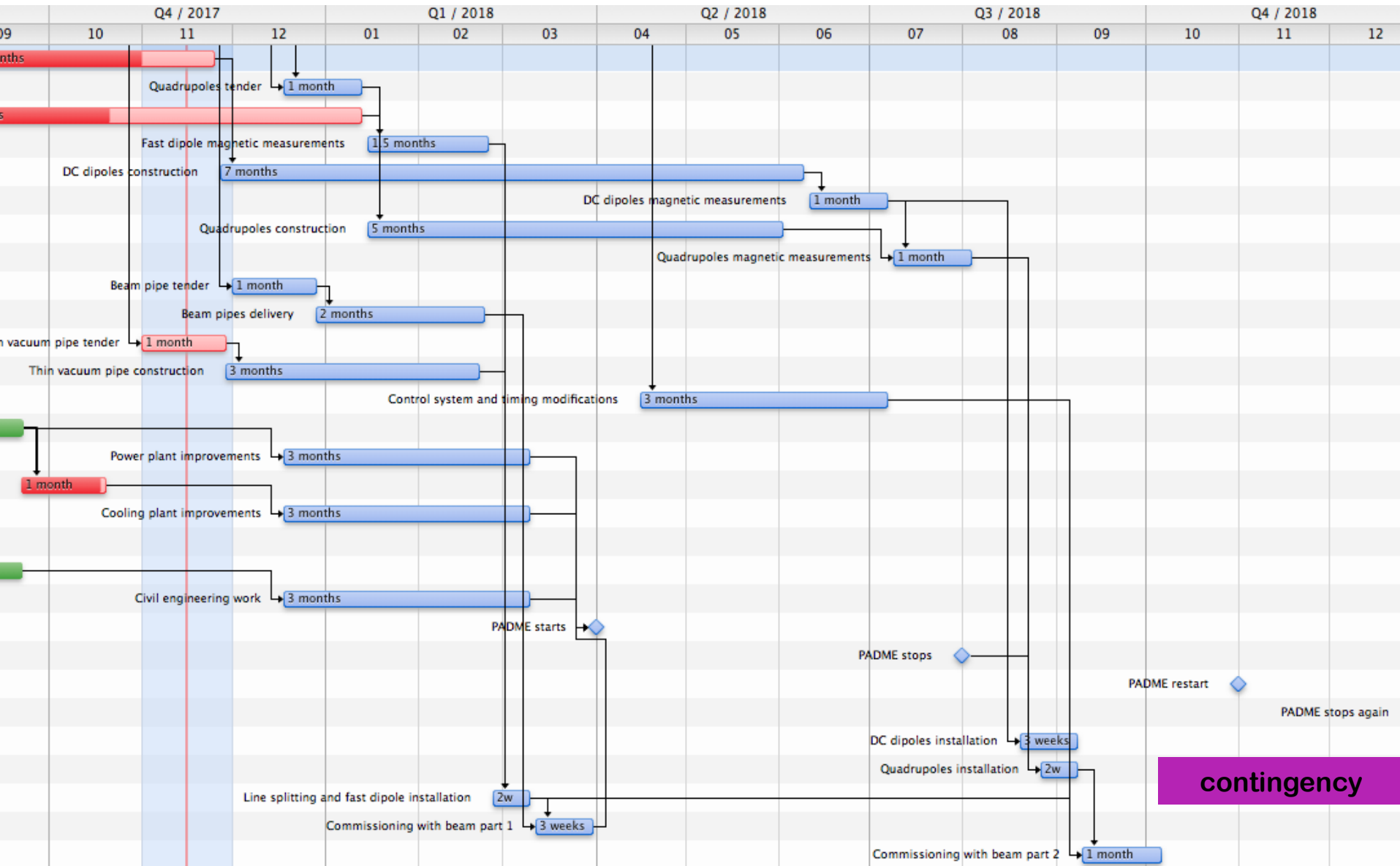

Figure 5: New VME board compact communication board, cabled to the tagging modules via flat cables, and the VME side of the SBS (Bit3) controller, installed in the BTF experimental area.

# New schedule (1/2)



# New schedule (2/2)



# Power, cooling & services

- Detailed estimate of additional electrical and thermal power
- **Technical solutions both for cooling and power identified**
  - New pumping and secondary circuit distribution for the BTF area
  - Revision and upgrade of power distribution for the area
- Detailed projects **assigned**



# Conclusions

- The doubling of BTF is ongoing.
- Beam reserved to PADME on line-1 from April to August
- Open call in second half of 2018 for last part of 2018/2019



# Timing

- DAFNE reference  $\emptyset_4$  for the injection systems
  - Conditioned  $\emptyset_4$  -> DELAYED LINAC SYS SIGNAL moves all the LINAC stuff together to match ACCUMULATOR phase)
    - DELAYED GUN SIGNAL -> LINAC SYS REFERENCE (once optimized, not moved for months)
    - BTF REFERENCE -> USER needs DELAYED LINAC SYS
- WE ARE WORKING in STATIC LINAC+BTF TRIGGERING SCHEME

Some Jitter contribution (see also AMY and UA9 experiences)

- LINAC SYS reference jitter (rms, 10ps, our best measure)
- LINAC GUN jitter (100ps)
- BTF STANFORD DDG535m single channel jitter (rms, 50ps + 0.01ppm of the channel delay) .

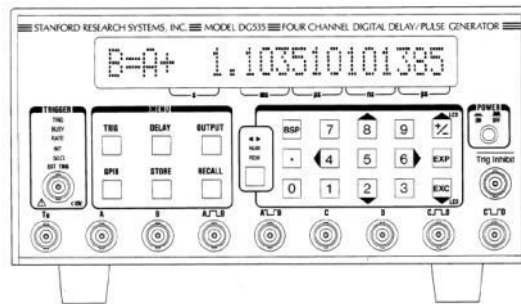



With  $1.1 \times 10^{11}$  n in the target:

- $8.8 \times 10^8$  n/cm<sup>2</sup>/s exiting from the target
- $1.87 \times 10^{10}$  γ/cm<sup>2</sup>/s exiting from the target

d (m)	$\times 10^{-7}$ n/cm <sup>2</sup> /pr
0.5	58
1	15
1.5	8

**At 1.5 m distance:**

Total neutron flux:  $8 \times 10^{-7}$  n/cm<sup>2</sup>/pr  $\pm 3\%$

Flux =  $4.5 \times 10^5$  n/cm<sup>2</sup>/s

Equivalent dose = 45 mSv/h

d (m)	$\times 10^{-5}$ γ/cm <sup>2</sup> /pr
0.5	63
1	5.7
1.5	1

**At 1.5 m distance**

Total photon flux =  $1 \times 10^6$  γ/cm<sup>2</sup>/s

# Neutron electro-production

Tungsten target

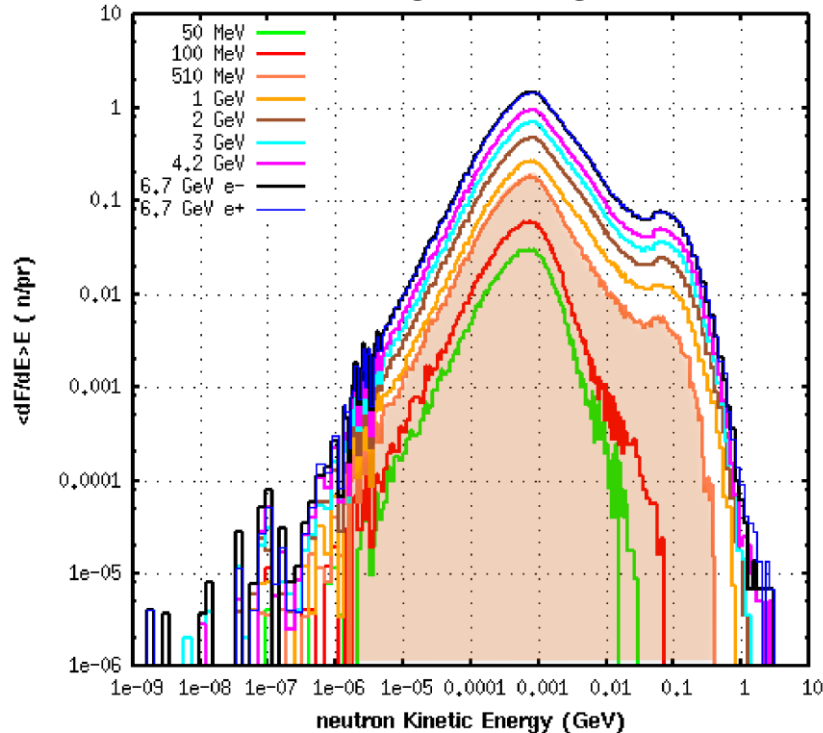

Evaporation peak + fast neutrons shoulder

- At full linac power:  $10^{13}$  e/s
  - to be compared e.g. with nELBE,  $N=6 \cdot 10^{15}$  e/s
- Swanson estimate
  - $9.3 \cdot 10^{10} Z^{(0.73 \pm 0.05)} \text{ n/s kW}^{-1}$
  - $2.15 \cdot 10^{12} \text{ n/s kW}^{-1}$  for Tungsten
- Optimizing the target configuration can (slightly) improve the yield:
  - n@BTF optimized target:  $2.75 \cdot 10^{12} \text{ n/s kW}^{-1}$
  - $0.218 \text{ n/pr}$  (over  $4\pi$  and all spectrum)

▪ In our case the main limitation will always be the intensity delivered onto the target

# PADME experiment

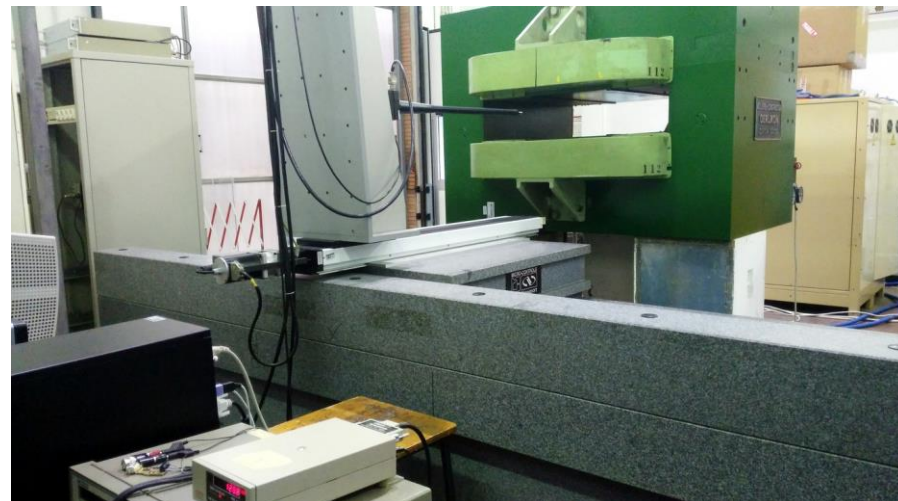
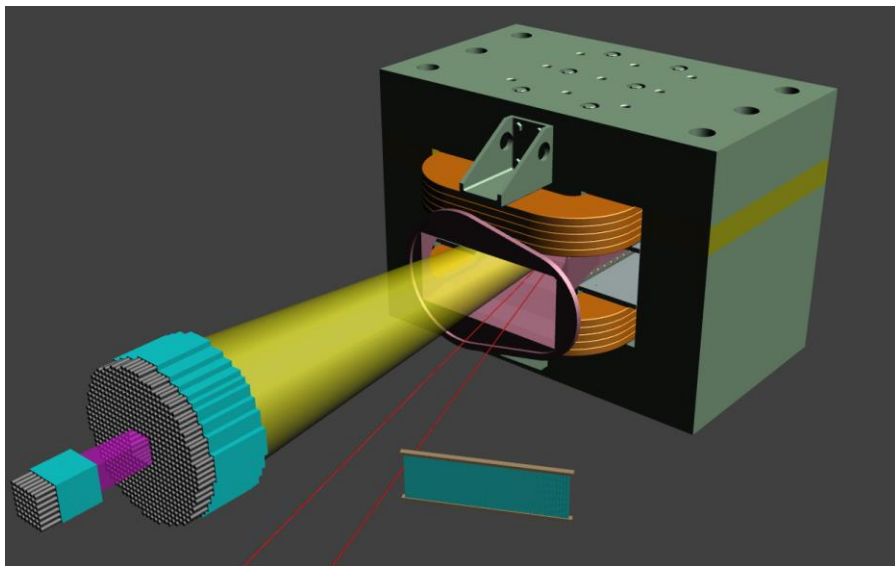

- CSN I full approval for 1,350 kEuro for 2016-2018
- Magnet from CERN (OK, being measured now)
- 500 BGO crystals from former L3 experiment
- Calorimeter construction starting in Spring 2016
- Active diamond target being developed in Lecce
- Scintillating bars positron veto being developed in Sofia
- Interest from Hungarian group
- Collaboration with Cornell starting this summer