

WAGASCI

SMRD Design & Installation

Integration Meeting - 2017/12/08

Side MRD Module

- ❖ **Two fully functional, independent modules**
- ❖ **Dimensions and Weight**
 - Dimensions ~H2.2 x W1.6 x 0.5 m
 - Weight ~9 tons
- ❖ **Composition**
 - 11 Steel plates
 - 30mm thick, 700 Kg each
 - 80 Scintillator bars with WLS Fiber
 - Section 7x200mm²
 - Length 1800mm
 - MPPC at both ends
 - Readout electronics at both ends

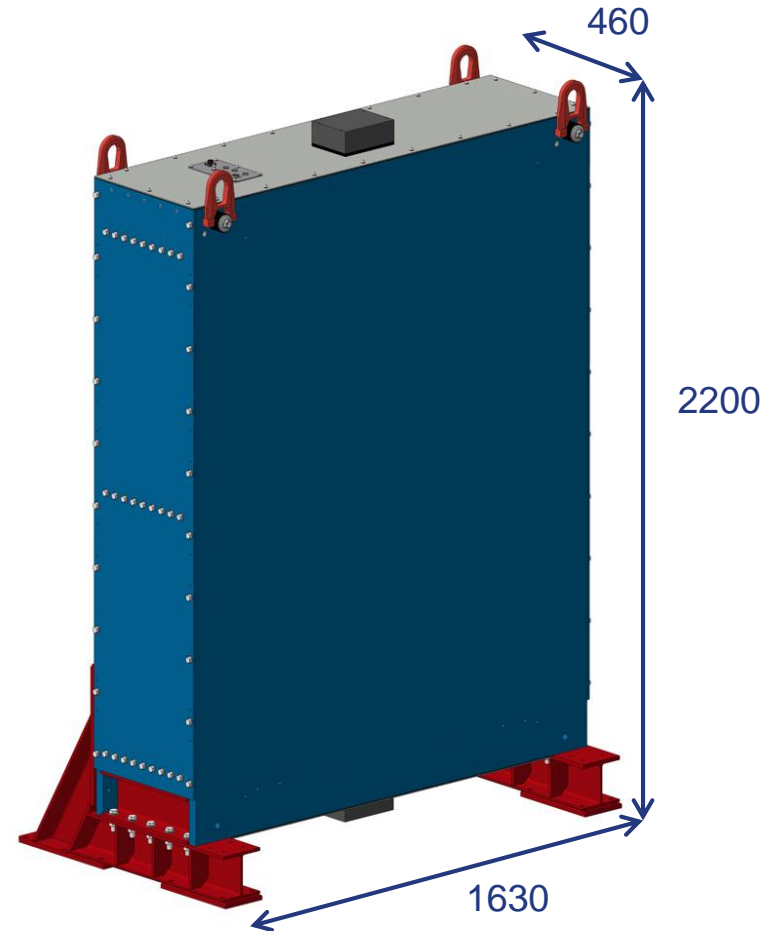

Integration - 1

- ❖ **All assembly tasks performed with Module in horizontal position**
 - Rotation jig attached to feet to rotate module into vertical position
- ❖ **Mechanical structure fully assembled before inserting the SciBars and mounting the electronics**
- ❖ **All the assembly work is done at Yokohama University**
 - Contractors for the heavy work, scientists and students for the rest

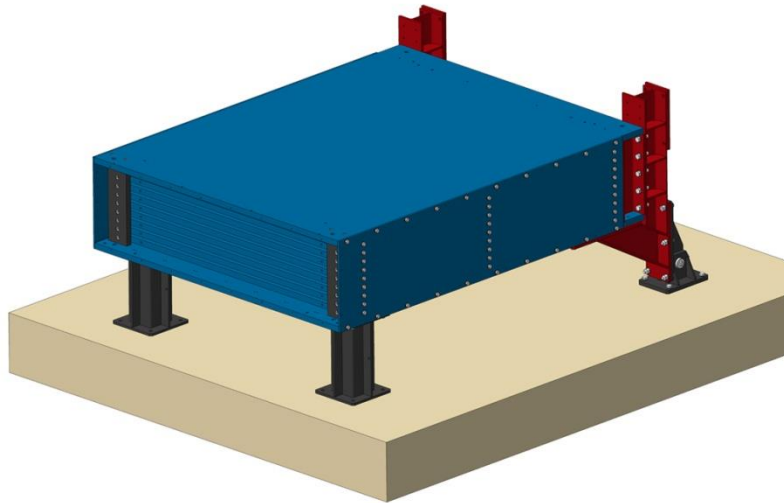

SMRD Assembled Mechanical Structure

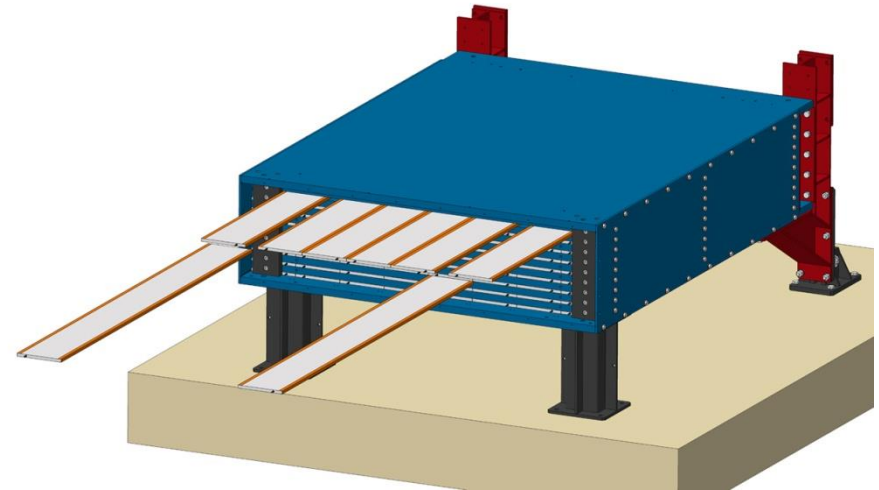

Inserting SciBars between Steel Plates

Integration - 2

- ❖ **MPPC Readout boards based on SPIROC Chip at both ends of SciBars – 3x ASU Boards**
- ❖ **Interface Boards with single HDMI link for data output**
- ❖ **Module sealed by 2 aluminum panels**
 - Patch panels with feedthrough connector for Power and Data links
 - Peltier Cooling Modules to keep temperature under control inside enclosure

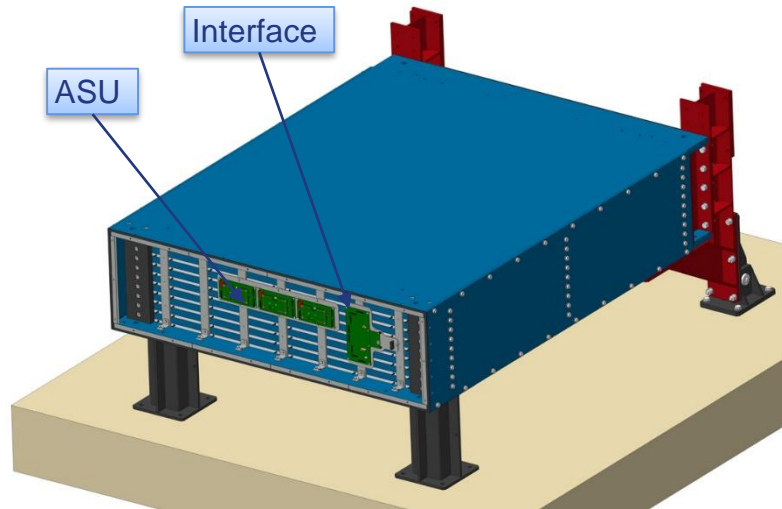

Mounting Electronics Readout Boards

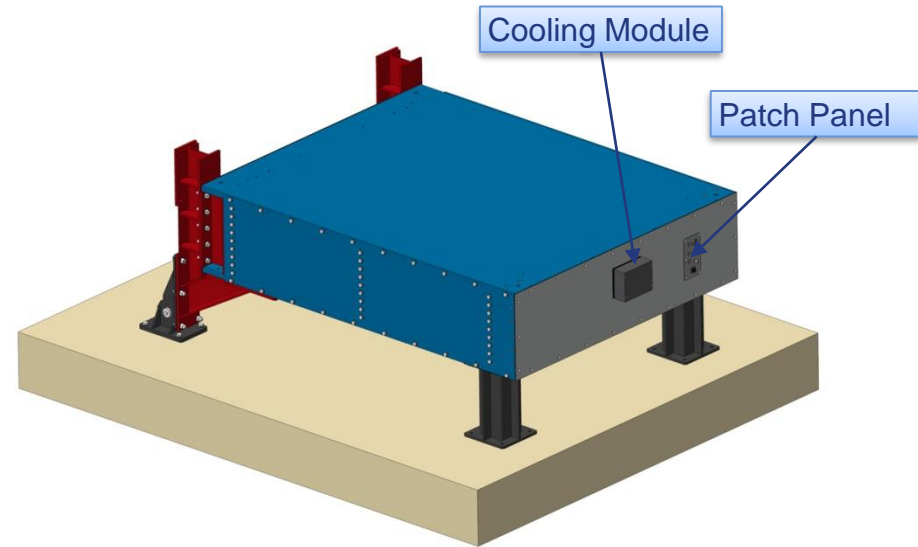

Sealing the Module – Ready for Testing

Installation

- ❖ **Seal anchor inserts in concrete floor at final location of modules**
 - Prepare drilling template
- ❖ **Transport modules on Flatbed truck from YNU to Tokai in horizontal position**
- ❖ **Unload in ND280 building with 10T crane and rotate to vertical configuration**
- ❖ **Move down pit to B2 floor**
- ❖ **Use hydraulic jacks and rollers to move the module to final position**
 - Use safety structure around module to prevent accidental tipping over when moving

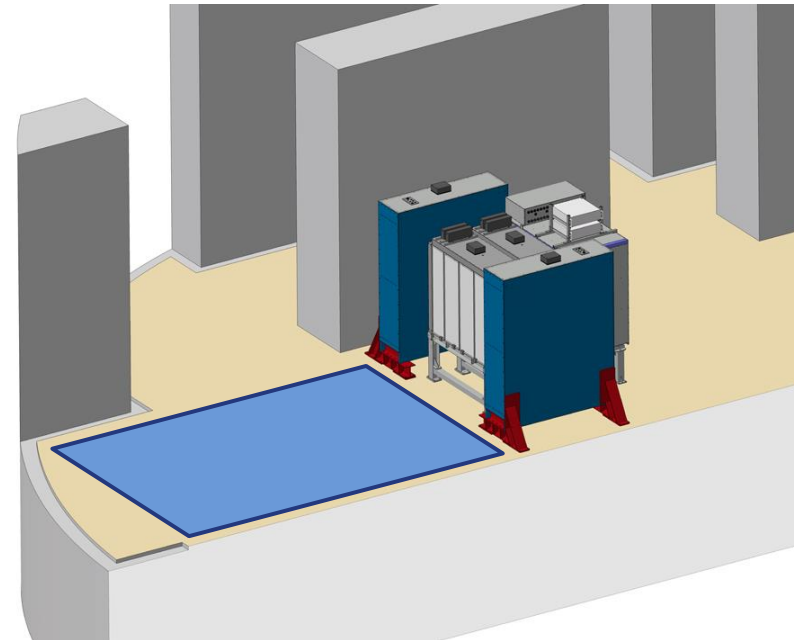

Installation - 2



- ❖ **Attach structure around module for stability when moving**
 - Commercial tubes with quick connections
 - Wheels
- ❖ **Weight of module is carried by rollers**

- ❖ **Use manual cable Puller to roll the module on B2 floor**



Installation - 2

- ❖ Changing direction requires to lift the Module with hydraulic jacks to rotate the rollers

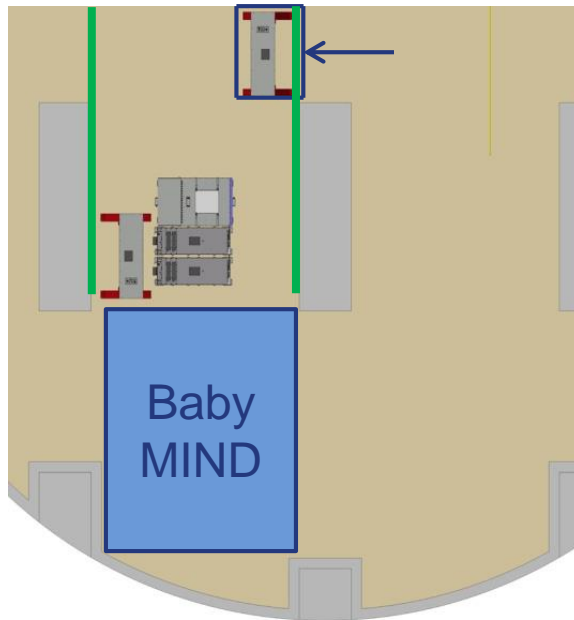

- ❖ Safety structure removed for final displacement
- ❖ Replaced by guide rails attached to concrete pillar
 - Simple H-Beam anchored to wall

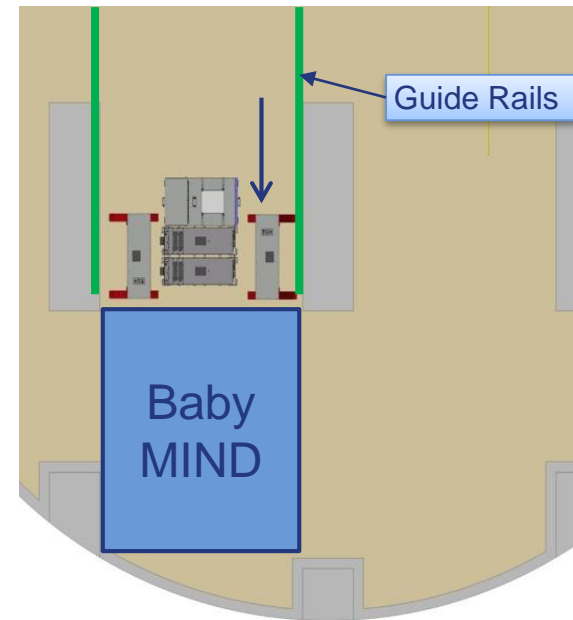

General Comments

- ❖ **Hydraulic Jacks and Rollers already extensively used to install and move INGRID Modules (similar weight and size)**
 - Contractors already have a lot of experience with them and know how to manage the difficulty
- ❖ **Floor is clean and smooth on B2 and air pads would have been a much better option but...**
 - Cost, no compressed air available in pit, schedule