

Beam Instrumentation & Diagnostics Part 1

CAS Introduction to Accelerator Physics

Constanța, 27th of September 2018

Peter Forck

Gesellschaft für Schwerionenforschung (GSI)

Beam Instrumentation: Functionality of devices & basic applications

Beam Diagnostics: Usage of devices for complex measurements

Diagnostics is the 'sensory organs' for the beam in the real environment.

(Referring to Volker Ziemann's lecture: 'Detecting imperfections to enable corrections')

Different demands lead to different installations:

- Quick, non-destructive measurements leading to a single number or simple plots
Used as a check for online information. Reliable technologies have to be used
Example: Current measurement by transformers
- Complex instruments for severe malfunctions, accelerator commissioning & development
The instrumentation might be destructive and complex
Example: Emittance determination, chromaticity measurement

General usage of beam instrumentation:

- Monitoring of beam parameters for operation, beam alignment & accelerator development
- Instruments for automatic, active beam control
Example: Closed orbit feedback at synchrotrons using position measurement by BPMs

Non-invasive (= 'non-intercepting' or 'non-destructive') methods are preferred:

- The beam is not influenced \Rightarrow the **same** beam can be measured at several locations
- The instrument is not destroyed due to high beam power

Outline of the Lectures



The ordering of the subjects is oriented by the beam quantities:

Part 1 of the lecture on electro-magnetic monitors:

- Current measurement
- Beam position monitors for bunched beams

Part 2 of the lecture on transverse and longitudinal diagnostics:

- Profile measurement
- Transverse emittance measure
- Measurement of longitudinal parameters

Lecture on Machin Protection System on Friday:

- Beam loss detection

Some instruments must be different for:

- Transfer lines with single pass \leftrightarrow synchrotrons with multi-pass
- Electrons are (nearly) always relativistic \leftrightarrow protons are at the beginning non-relativistic

Remark: Most instrumentation is installed outside of rf-cavities to prevent for signal disturbance

Typical Installation of a Beam Instrument

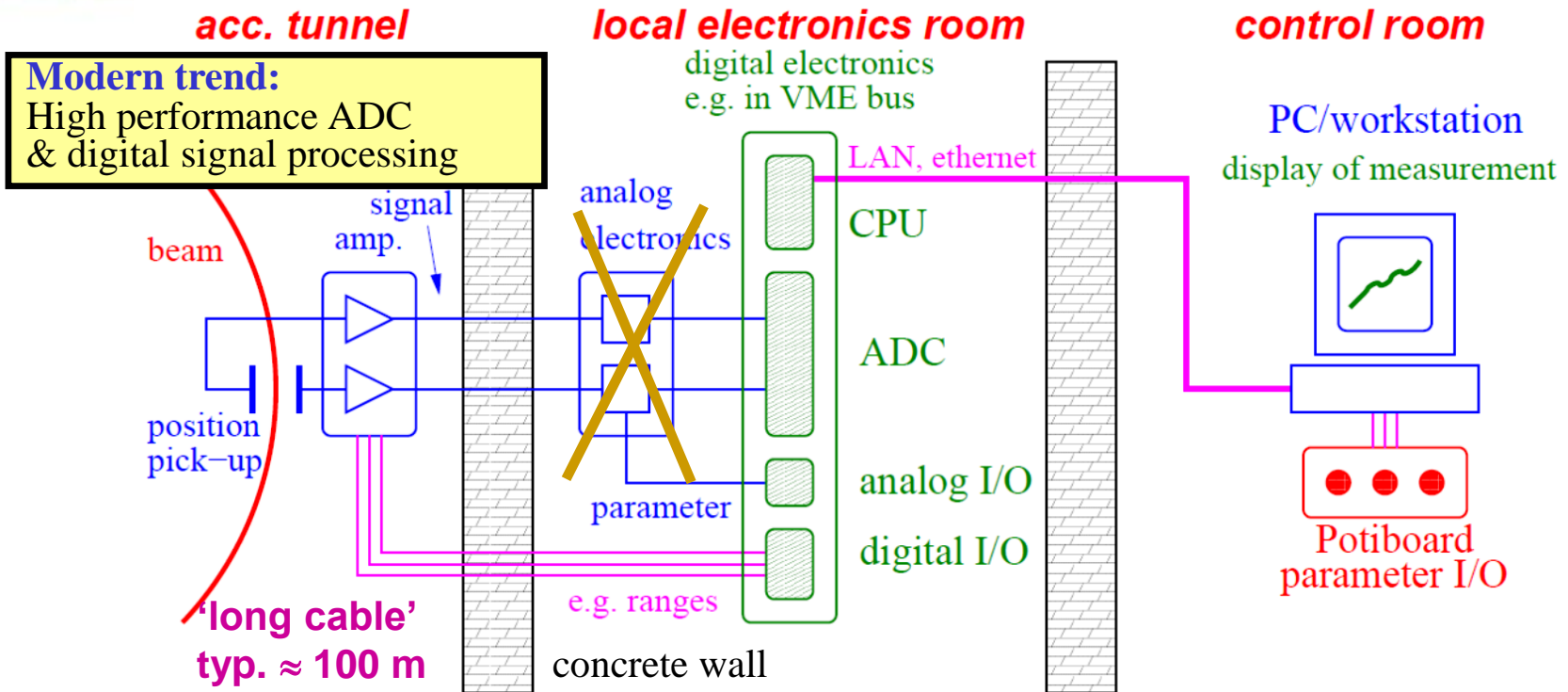

- accelerator tunnel:**
 - action of the beam to the detector
 - low noise pre-amplifier and first signal shaping
- local electronics room:**
 - analog treatment, partly combining other parameters
 - digitalization, data bus systems (GPIB, VME, cPCI, μ TCA...)
- control room:**
 - visualization and storage on PC farm
 - parameter setting of the beam and the instruments

Measurement of Beam Current

The beam current and its time structure the basic quantity of the beam.

- It is the first check of the accelerator functionality
- It has to be determined in an absolute manner
- Important for transmission measurement and to prevent for beam losses.

Different devices are used:

- **Transformers:** Measurement of the beam's **magnetic field**
 - Non-destructive
 - No dependence on beam type and energy
 - They have lower detection threshold.
- **Faraday cups:** Measurement of the beam's **electrical charges**

Magnetic field of the beam and the ideal Transformer

➤ Beam current of N_{part} charges with velocity β

$$I_{beam} = qe \cdot \frac{N_{part}}{t} = qe \cdot \beta c \cdot \frac{N_{part}}{l}$$

➤ cylindrical symmetry

→ only azimuthal component

$$\vec{B} = \mu_0 \frac{I_{beam}}{2\pi r} \cdot \vec{e}_\varphi$$

Example: $I = 1\mu\text{A}$, $r = 10\text{cm} \Rightarrow B_{beam} = 2\text{pT}$, earth $B_{earth} = 50\mu\text{T}$

Idea: Beam as primary winding and sense by sec. winding.

⇒ Loaded current transformer

$$I_1/I_2 = N_2/N_1 \Rightarrow I_{sec} = 1/N \cdot I_{beam}$$

➤ Inductance of a torus of μ_r

$$L = \frac{\mu_0 \mu_r}{2\pi} \cdot l N^2 \cdot \ln \frac{r_{out}}{r_{in}}$$

➤ Goal of torus: Large inductance L and guiding of field lines.

Definition: $U = L \cdot dI/dt$

magnetic field B

at radius r:

$$B \sim 1/r$$

$$\vec{B} \parallel \vec{e}_\varphi$$

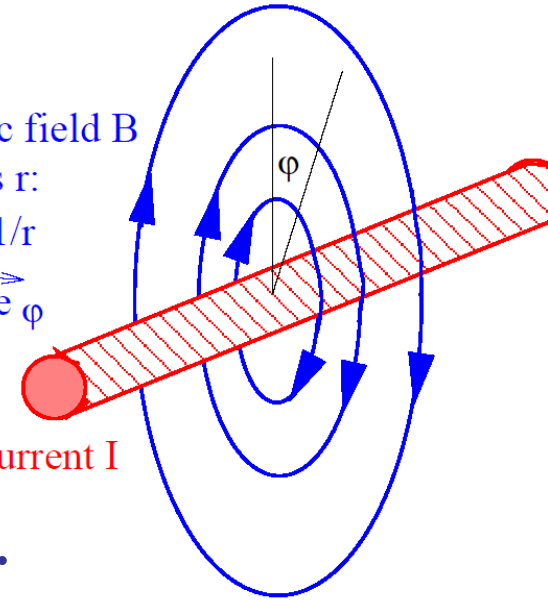

beam current I

Torus to guide the magnetic field

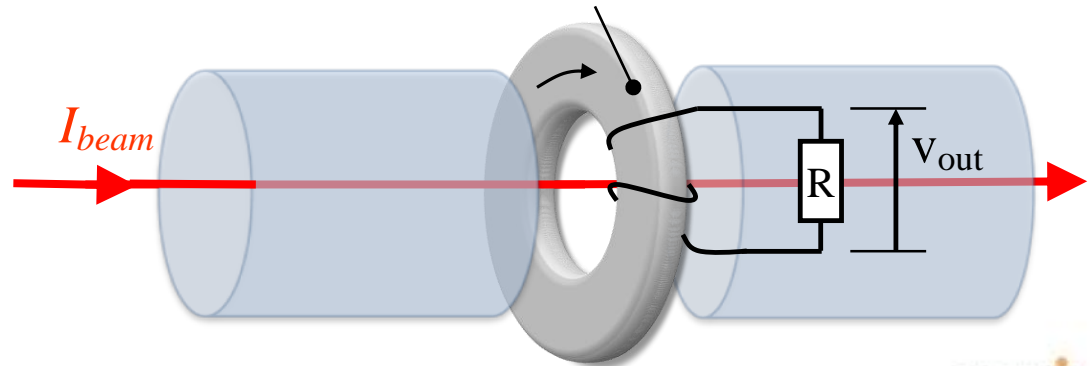

Fast Current Transformer FCT (or Passive Transformer)



Simplified electrical circuit of a passively loaded transformer:

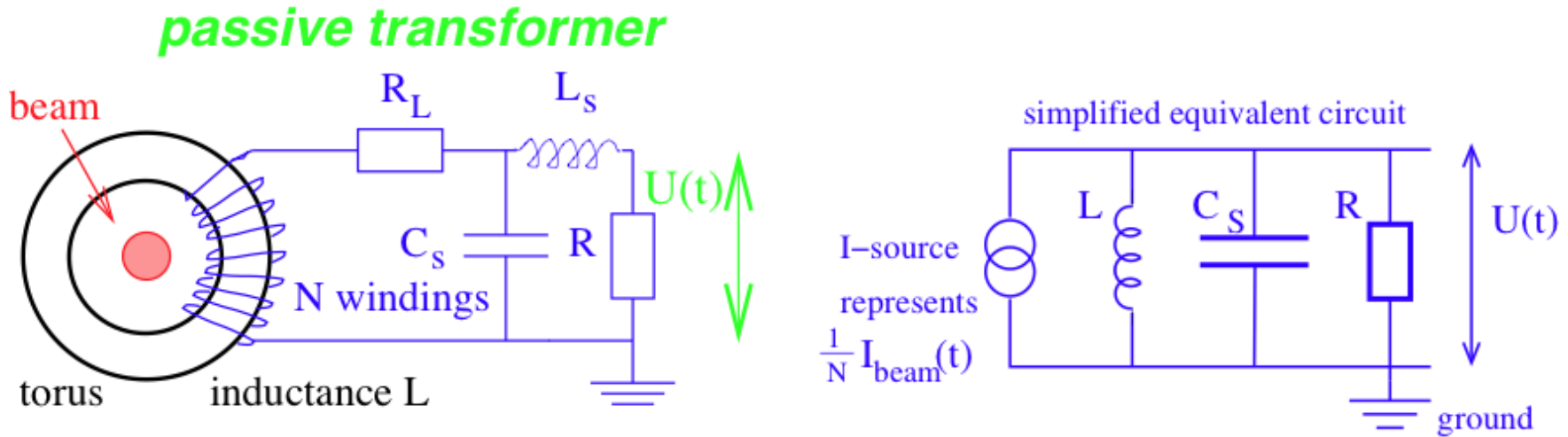

A voltage is measured: $U = R \cdot I_{sec} = R / N \cdot I_{beam} \equiv S \cdot I_{beam}$

with S sensitivity [V/A], equivalent to transfer function or transfer impedance Z

Equivalent circuit for analysis of sensitivity and bandwidth (without loss resistivity R_L)

Response of the Passive Transformer: Rise and Droop Time



Time domain description:

Droop time: $\tau_{droop} = 1/(2\pi f_{low}) = L/R$

Rise time: $\tau_{rise} = 1/(2\pi f_{high}) = 1/RC_S$ (ideal without cables)

Rise time: $\tau_{rise} = 1/(2\pi f_{high}) = \sqrt{L_S C_S}$ (with cables)

R_L : loss resistivity, R : for measuring.

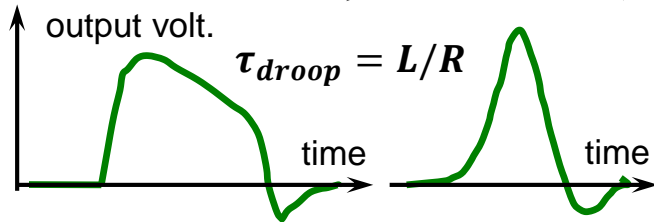
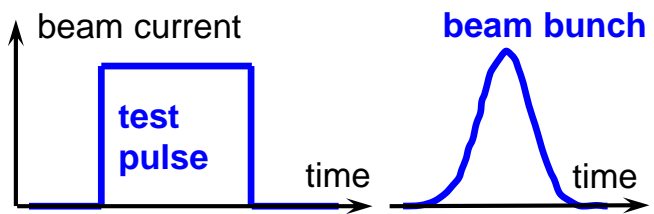
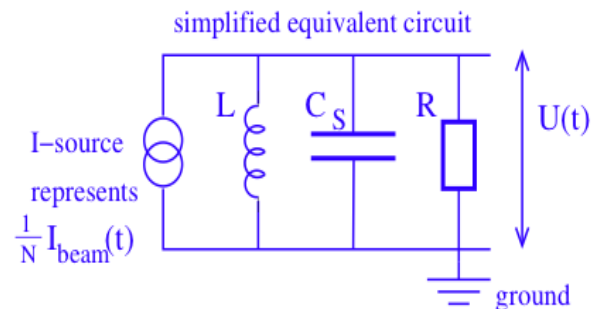

$$\tau_{rise} = \sqrt{L \cdot C_S}$$

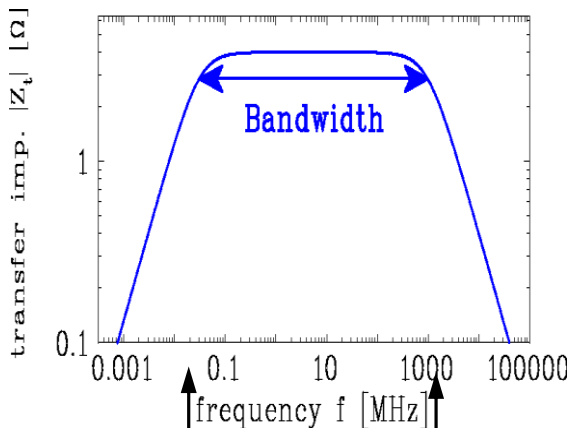

$$2\pi f_{low} = R/L$$

$$2\pi f_{high} = 1/RC_S$$

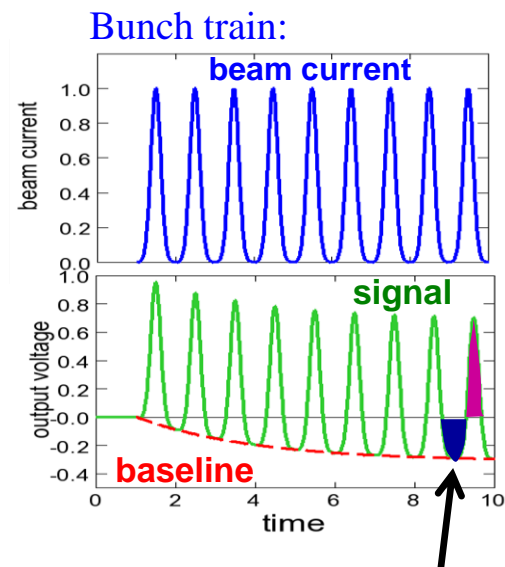

Baseline: $U_{base} \propto 1 - \exp(-t/\tau_{droop})$
 positive & negative areas are equal

Example for Fast Current Transformer

From
Company Bergoz



Ø 200 mm

For bunch beams e.g. during accel. in a synchrotron
typical bandwidth of $2 \text{ kHz} < f < 1 \text{ GHz}$

$\Leftrightarrow 10 \text{ ns} < t_{\text{bunch}} < 1 \text{ } \mu\text{s}$ is well suited

Example GSI type:

Inner / outer radius	70 / 90 mm
Permeability	$\mu_r \approx 10^5$ for $f < 100\text{kHz}$ $\mu_r \propto 1/f$ above
Windings	10
Sensitivity	4 V/A for $R = 50 \Omega$
Droop time $\tau_{\text{droop}} = L/R$	0.2 ms
Rise time $\tau_{\text{rise}} = \sqrt{L_S C_S}$	1 ns
Bandwidth	2 kHz ... 500 MHz

Example: U^{73+} from 11 MeV/u ($\beta = 15 \%$) to 350 MeV/u
within 300 ms (displayed every 0.15 ms)

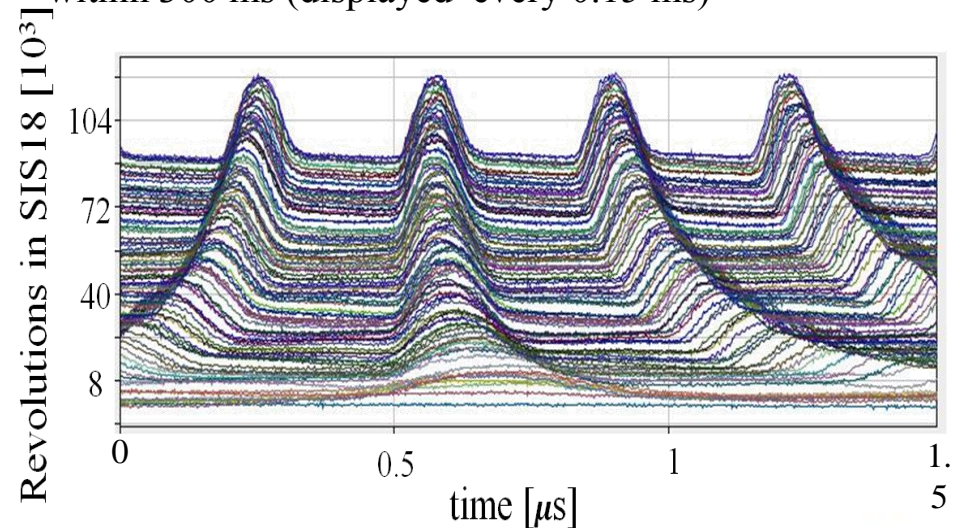
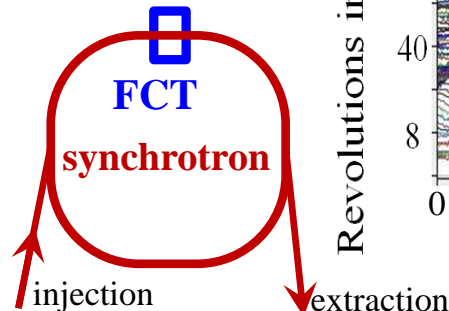
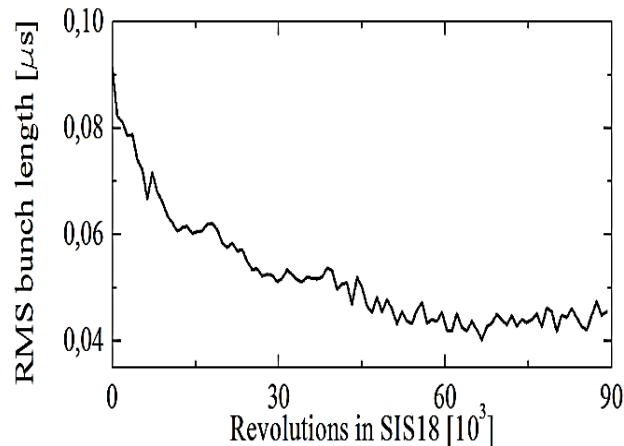

Example for Fast Current Transformer

For bunch beams e.g. transfer between synchrotrons
 typical bandwidth of $2 \text{ kHz} < f < 1 \text{ GHz}$
 $\Leftrightarrow 1 \text{ ns} < t_{\text{batch}} < 200 \mu\text{s}$ is well suited

Example GSI type:

Inner / outer radius	70 / 90 mm
Permeability	$\mu_r \approx 10^5$ for $f < 100\text{kHz}$ $\mu_r \propto 1/f$ above
Windings	10
Sensitivity	4 V/A for $R = 50 \Omega$
Droop time $\tau_{\text{droop}} = L/R$	0.2 ms
Rise time $\tau_{\text{rise}} = \sqrt{L_S C_S}$	1 ns
Bandwidth	2 kHz ... 500 MHz

Numerous application e.g.:

- Transmission optimization
- Bunch shape measurement
- Input for synchronization of 'beam phase'

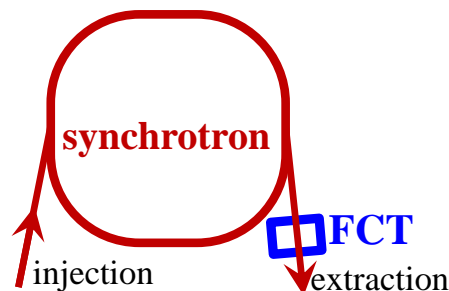

From
Company Bergoz



Fast extraction from GSI synchrotron:

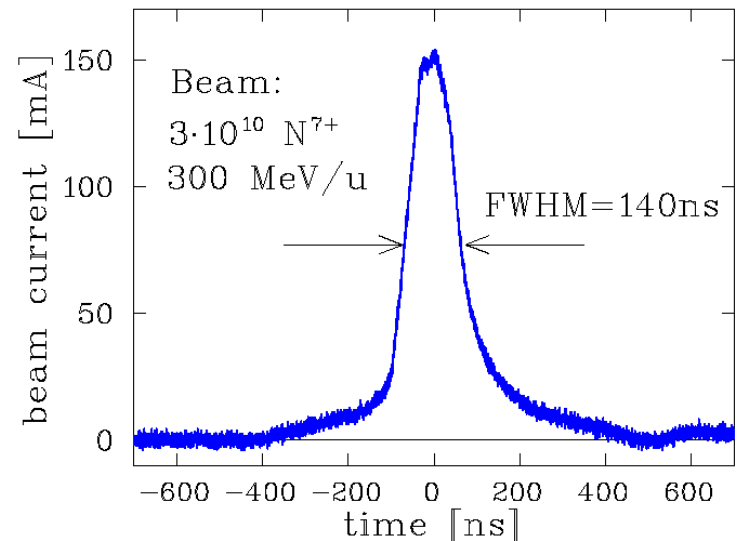

Shielding of a Transformer

Task of the shield:

- The image current of the walls have to be bypassed by a gap and a metal housing.
- This housing uses μ -metal and acts as a shield of external B-field
(remember: $I_{beam} = 1 \mu\text{A}$, $r = 10 \text{ cm} \Rightarrow B_{beam} = 2\text{pT}$, earth field $B_{earth} = 50 \mu\text{T}$)

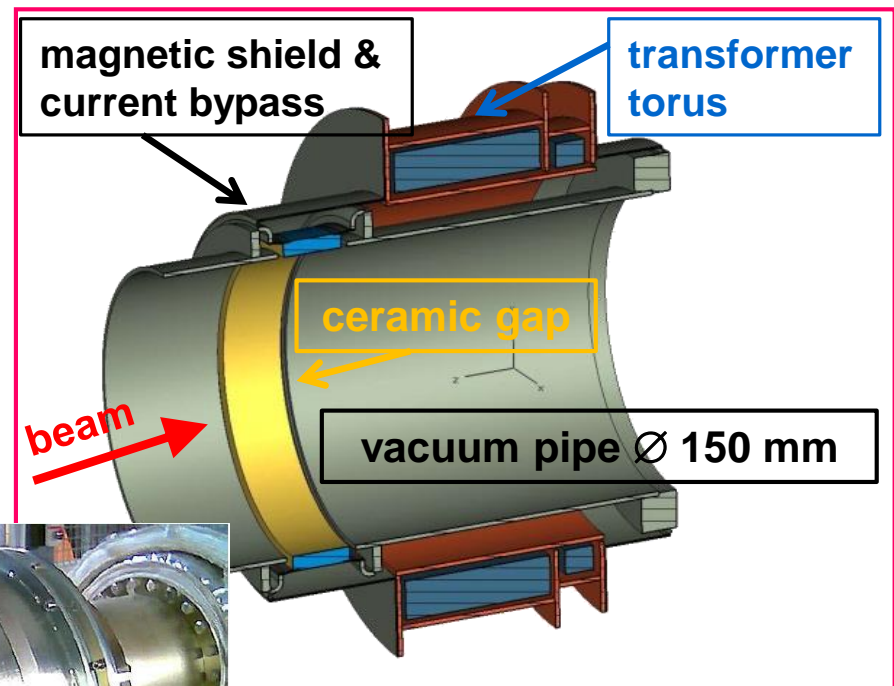
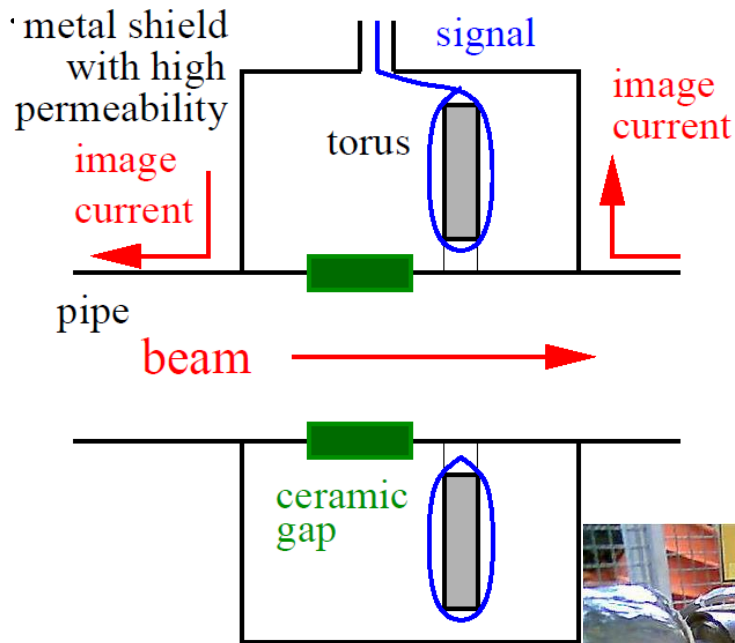

The dc Transformer

How to measure the DC current? The current transformer discussed sees only B-flux *changes*. The DC Current Transformer (DCCT) → look at the magnetic saturation of two torii.

- **Modulation** of the primary windings forces both torii into saturation twice per cycle
- **Sense windings** measure the modulation signal and cancel each other.
- But with the I_{beam} , the saturation is shifted and I_{sense} is not zero
- **Compensation current** adjustable until I_{sense} is zero once again

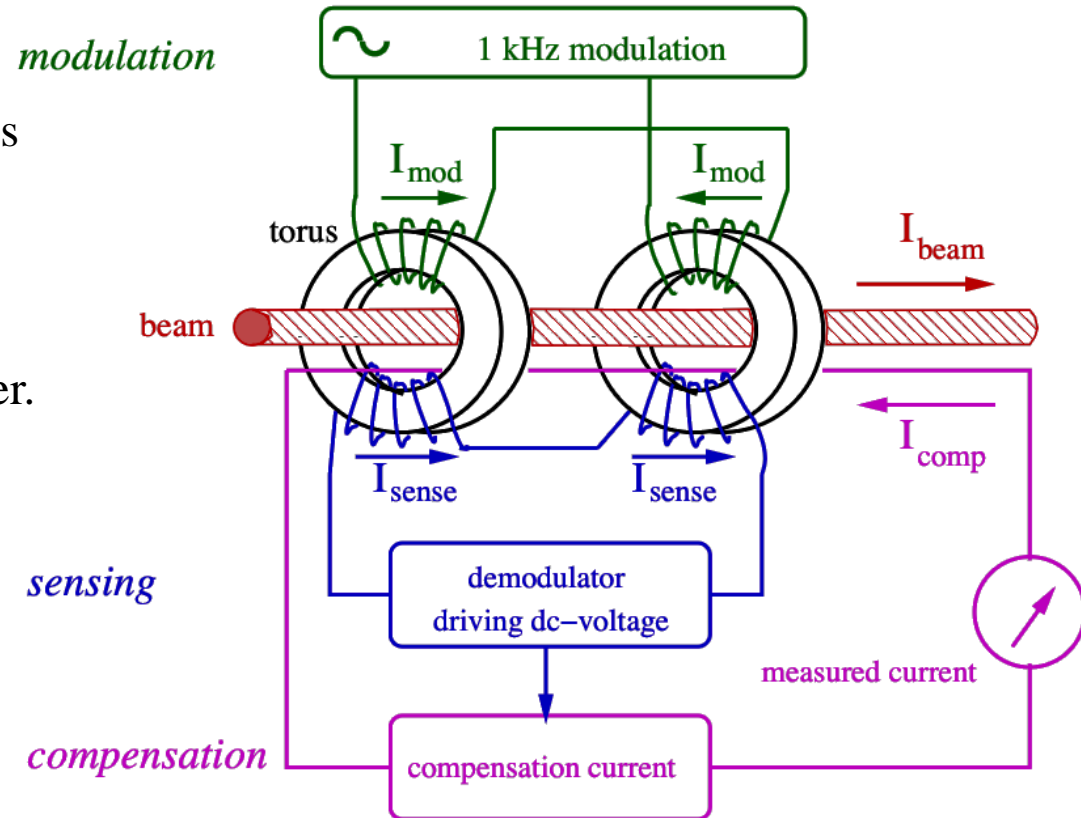

The dc Transformer

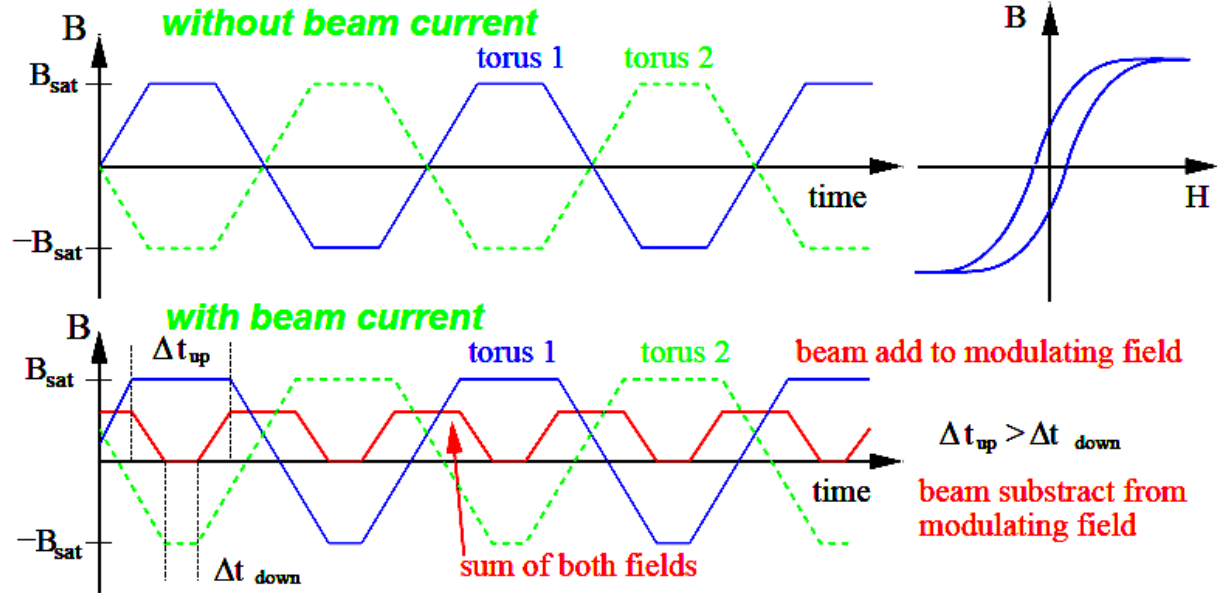

➤ **Modulation without beam:**

typically about 9 kHz to saturation → **no net flux**

➤ **Modulation with beam:**

saturation is reached at different times, → net flux

➤ **Net flux:** double frequency than modulation

➤ **Feedback:** Current fed to compensation winding

for larger sensitivity

➤ **Two magnetic cores:** Must be very similar.

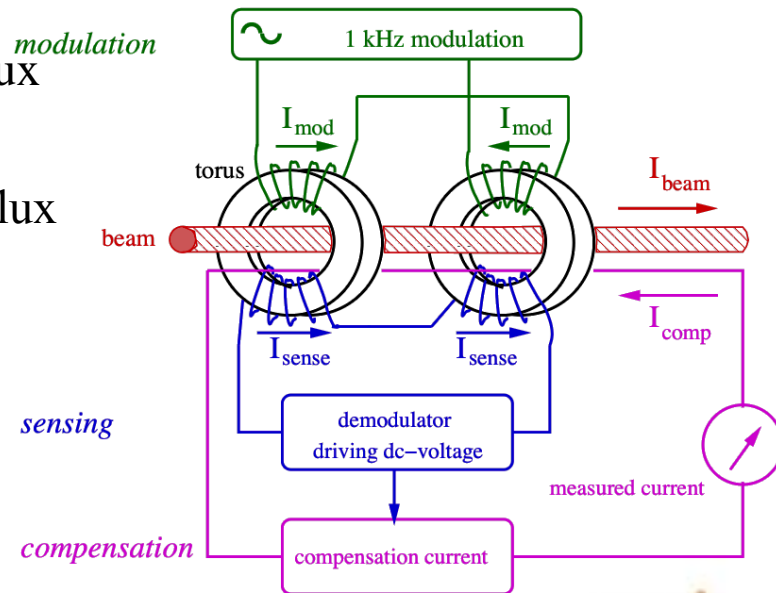

The dc Transformer Realization

Example: The DCCT at GSI synchrotron

Torus radii	$r_i = 135 \text{ mm}$ $r_o = 145 \text{ mm}$
Torus thickness	$d = 10 \text{ mm}$
Torus permeability	$\mu_r = 10^5$
Saturation inductance	$B_{\text{sat}} = 0.6 \text{ T}$
Number of windings	16 for modulation & sensing 12 for feedback
Resolution	$I_{\text{beam}}^{\text{min}} = 2 \text{ } \mu\text{A}$
Bandwidth	$\Delta f = \text{dc} \dots 20 \text{ kHz}$
Rise time constant	$\tau_{\text{rise}} = 10 \text{ } \mu\text{s}$
Temperature drift	$1.5 \text{ } \mu\text{A}/^\circ\text{C}$

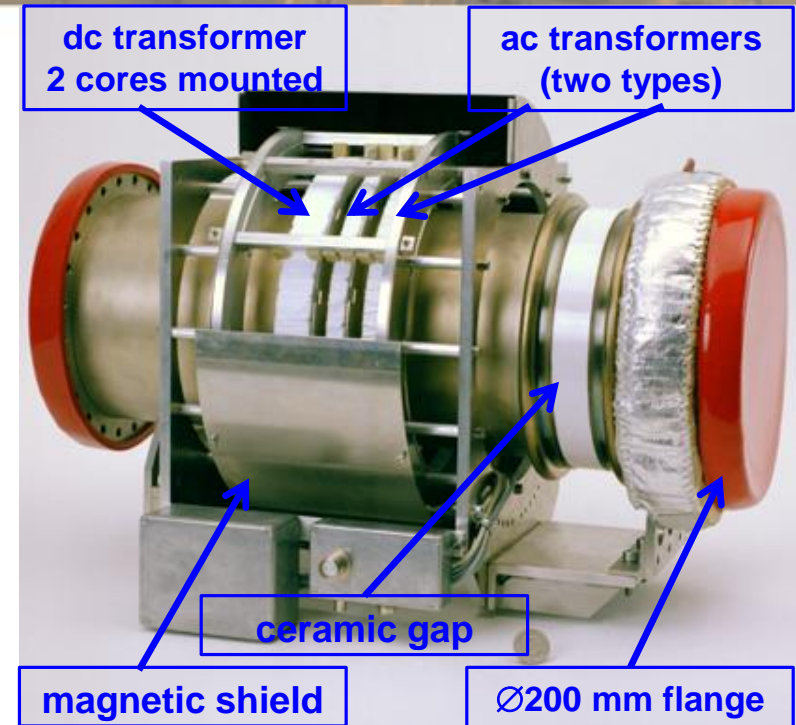

Measurement with a dc Transformer

Application for dc transformer:

⇒ Observation of beam behavior with typ. 20 μs time resolution → **the basic operation tool**

Example: The DCCT at GSI synchrotron:

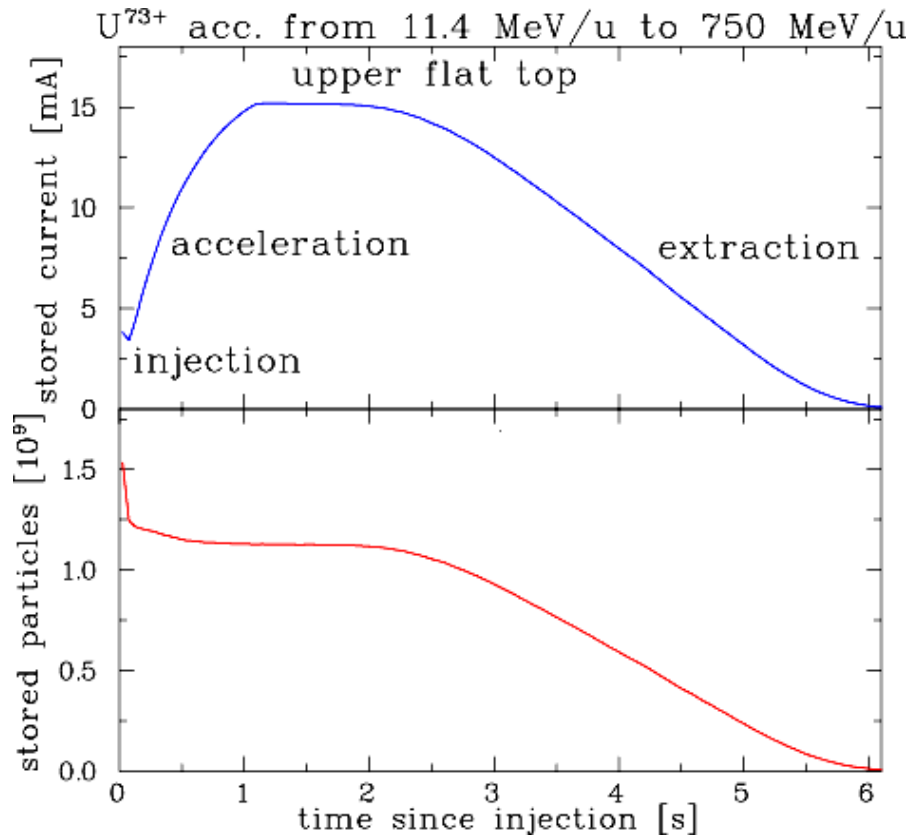

Important parameter:

Detection threshold: $\approx 1 \mu\text{A}$

(= resolution)

Bandwidth: $\Delta f = \text{dc to } 20 \text{ kHz}$

Rise-time: $t_{\text{rise}} = 20 \mu\text{s}$

Temperature drift: $1.5 \mu\text{A}/^\circ\text{C}$

⇒ compensation required.

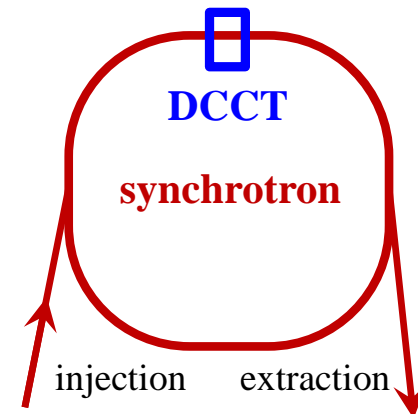

Measurement of Beam Current



➤ **Transformers:** Measurement of the beam's **magnetic field**

Non-destructive

No dependence on beam type and energy

They have lower detection threshold.

➤ **Faraday cups:** Measurement of the beam's **electrical charges**

They are destructive

For low energies only

Low currents can be determined.

Energy Loss of Protons & Ions

Bethe Bloch formula:
(simplest formulation)

$$-\frac{dE}{dx} = 4\pi N_A r_e m_e c^2 \cdot \frac{Z_t}{A_t} \rho_t \cdot \frac{Z_p^2}{\beta^2} \left(\ln \frac{2m_e c^2 \gamma^2 \beta^2}{I} - \beta^2 \right)$$

Semi-classical approach:

- Projectiles of mass M collide with free electrons of mass m
- If $M \gg m$ then the relative energy transfer is low
⇒ many collisions required many electrons participate
proportional to target electron density $n_e = \frac{Z_t}{A_t} \rho_t$

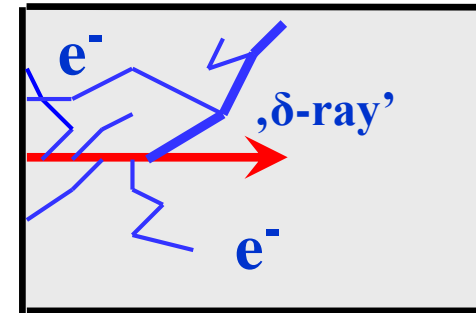

⇒ low straggling for the heavy projectile i.e. ‘straight trajectory’

- If projectile velocity $\beta \approx 1$ low relative energy change of projectile (γ is Lorentz factor)
- I is mean ionization potential including kinematic corrections $I \approx Z_t \cdot 10 \text{ eV}$ for most metals
- Strong dependence on projectile charge Z_p

Constants: N_A Avogadro number, r_e classical e^- radius, m_e electron mass, c velocity of light

Energy Loss of Protons & Ions in Copper

Bethe Bloch formula:
$$-\frac{dE}{dx} = 4\pi N_A r_e m_e c^2 \cdot \frac{Z_t}{A_t} \rho_t \cdot \frac{Z_p^2}{\beta^2} \left(\ln \frac{2m_e c^2 \gamma^2 \beta^2}{I} - \beta^2 \right)$$

Range:
$$R = \int_0^{E_{\max}} \left(\frac{dE}{dx} \right)^{-1} dE$$

with approx. scaling $R \propto E_{\max}^{1.75}$

Numerical calculation for **ions**

with semi-empirical model e.g. SRIM

Main modification $Z_p \rightarrow Z_p^{\text{eff}}(E_{\text{kin}})$

⇒ **Cups only for**

$E_{\text{kin}} < 100 \text{ MeV/u}$ due to $R < 10 \text{ mm}$

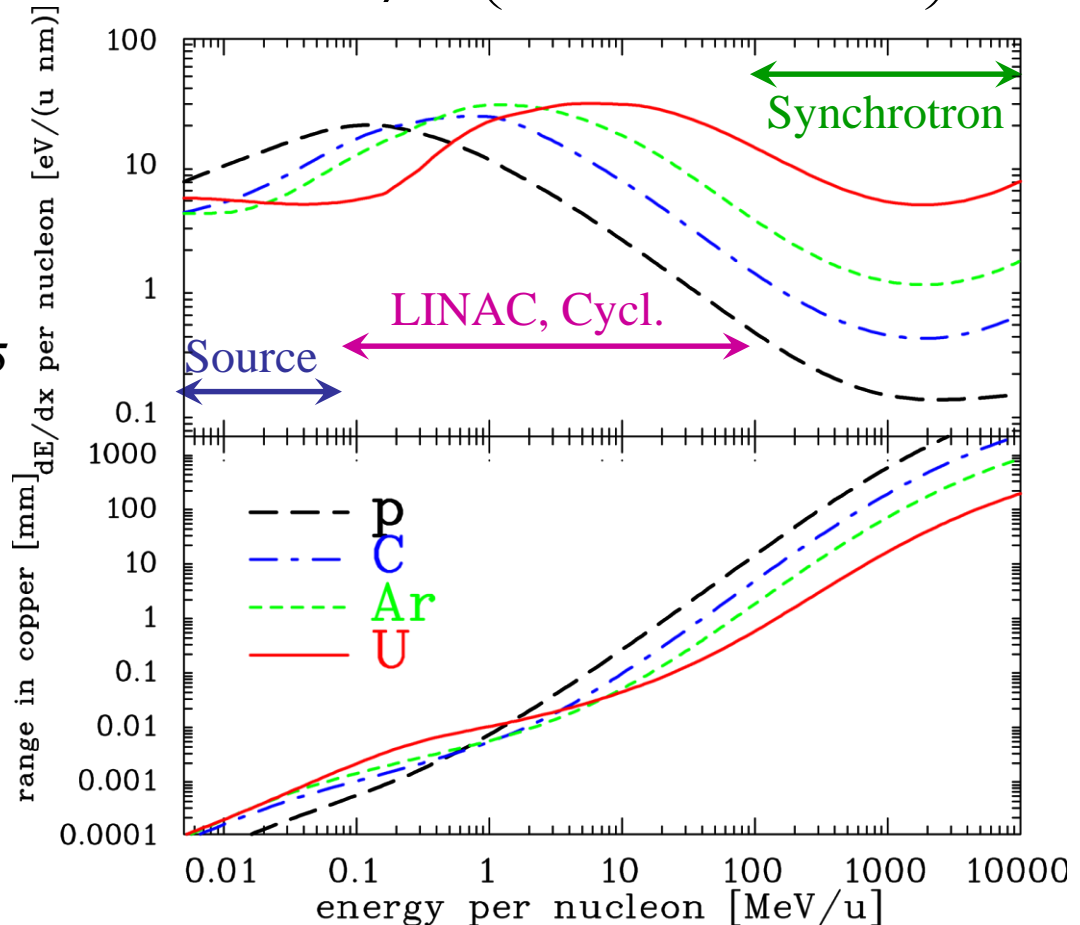

Secondary Electron Emission caused by Ion Impact

Energy loss of ions in metals close to a surface:

Closed collision with large energy transfer: \rightarrow fast e^- with $E_{kin} > 100$ eV

Distant collision with low energy transfer \rightarrow slow e^- with $E_{kin} \leq 10$ eV

\rightarrow 'diffusion' & scattering with other e^- : scattering length $L_s \approx 1 - 10$ nm

\rightarrow at surface ≈ 90 % probability for escape

Secondary **electron yield** and energy distribution comparable for all metals!

$\Rightarrow Y = const. * dE/dx$ (Sternglass formula)

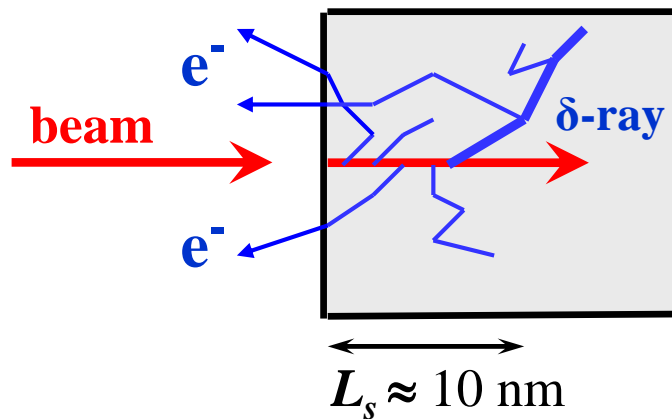

E.J. Sternglass, Phys. Rev. 108, 1 (1957)

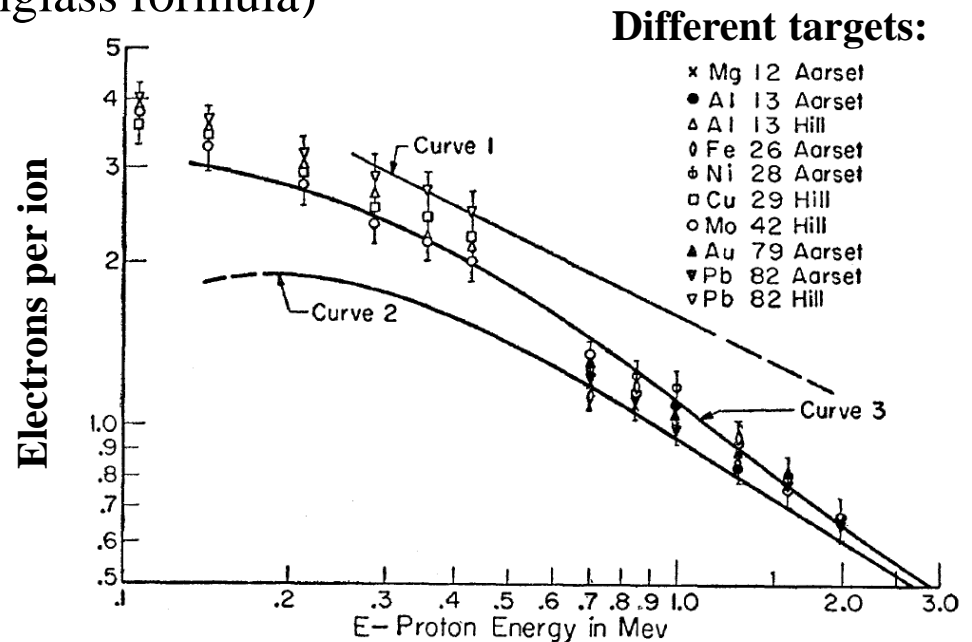

Faraday Cups for Beam Charge Measurement

The beam particles are collected inside a metal cup
 ⇒ The beam's charge are recorded as a function of time.

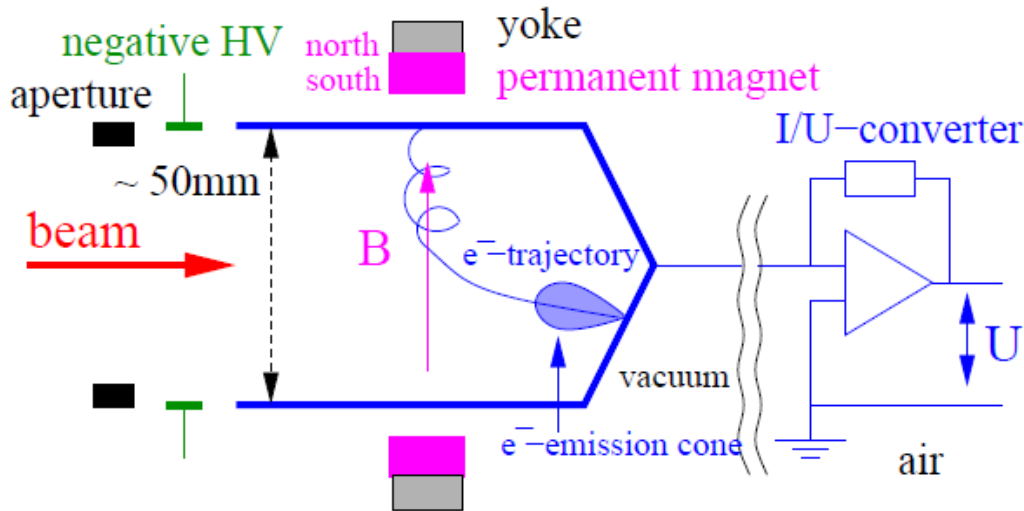

The cup is moved in the beam pass
 → destructive device

Currents down to 10 pA with bandwidth of 100 Hz!

To prevent for secondary electrons leaving the cup

Magnetic field:

The central field is $B \approx 10 \text{ mT} \Rightarrow r_c = \frac{mB}{e} \cdot v_{\perp} \approx 1 \text{ mm} .$

or **Electric field:** Potential barrier at the cup entrance $U \approx 1 \text{ kV}.$

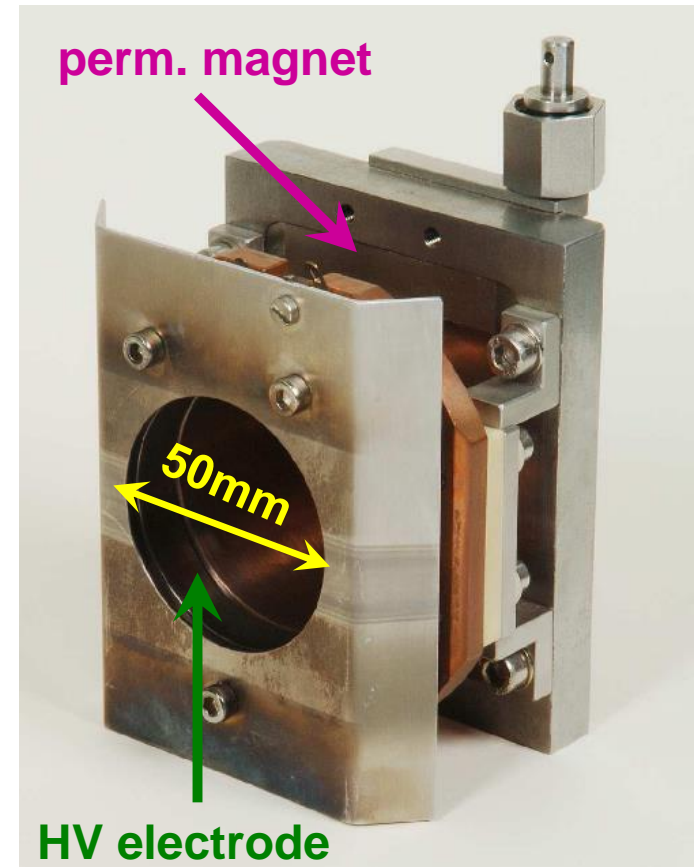

Realization of a Faraday Cup at GSI LINAC

The Cup is moved into the beam pass.

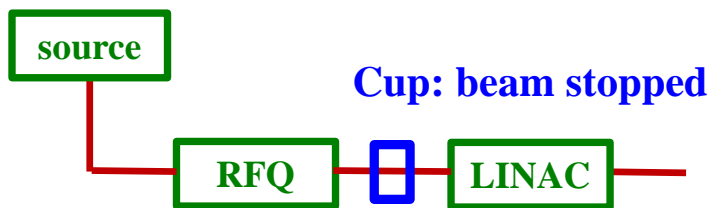
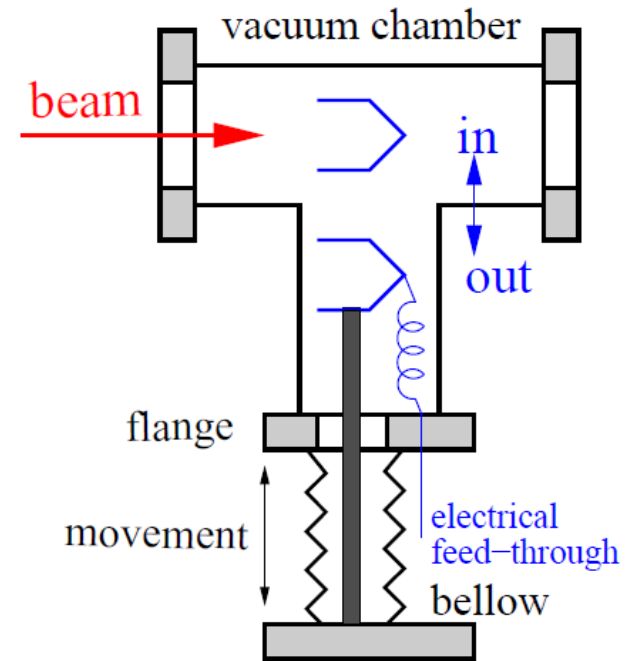
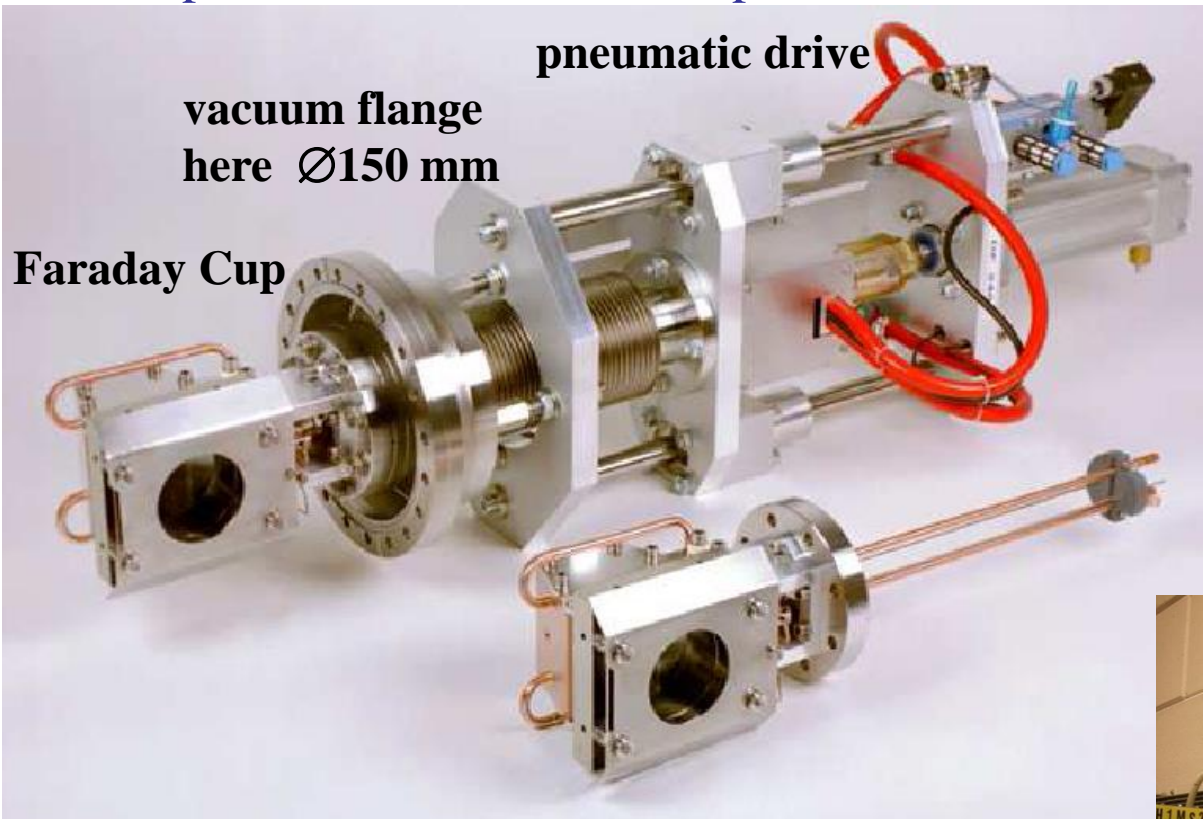

Summary for Current Measurement

Transformer: → measurement of the beam's magnetic field

- Magnetic field is guided by a high μ toroid
- **Types:** FCT → large bandwidth, $I_{min} \approx 30 \mu\text{A}$, BW = 10 kHz ... 500 MHz
 [ACT : $I_{min} \approx 0.3 \mu\text{A}$, BW = 10 Hz 1 MHz, used at proton LINACs]
 DCCT: two toroids + modulation, $I_{min} \approx 1 \mu\text{A}$, BW = dc ... 20 kHz
- non-destructive, used for all beams

Faraday cup: → measurement of beam's charge,

- low threshold by I/U-converter: $I_{beam} > 10 \text{ pA}$
- totally destructive, used for low energy beams only

Fast Transformer FCT

Active transformer ACT

DC transformer DCCT

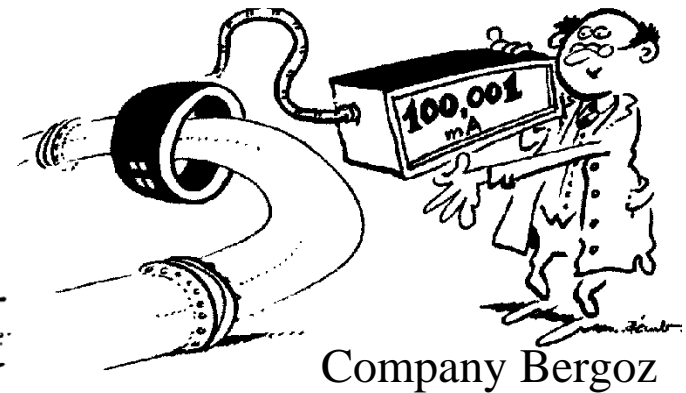
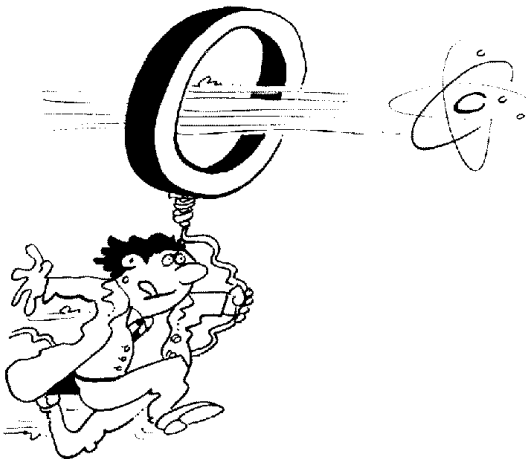

Company Bergoz

Outline:

- Signal generation → transfer impedance
- Capacitive *button* BPM for high frequencies
- Capacitive *linear-cut* BPM for low frequencies
- Electronics for position evaluation
- BPMs for measurement
- Summary

A Beam Position Monitor is a non-destructive device for bunched beams

1. It delivers information about the transverse center of the beam

- *Trajectory*: Position of an individual bunch within a transfer line or synchrotron
- *Closed orbit*: Central orbit averaged over a period much longer than a betatron oscillation
- *Single bunch position*: Determination of parameters like tune, chromaticity, β -function

Remarks: BPMs have a low cut-off frequency \Leftrightarrow . dc-beam behavior can't be monitored

The abbreviation **BPM** and pick-up **PU** are synonyms

Time Domain ↔ Frequency Domain

Time domain: Recording of a voltage as a function of time:

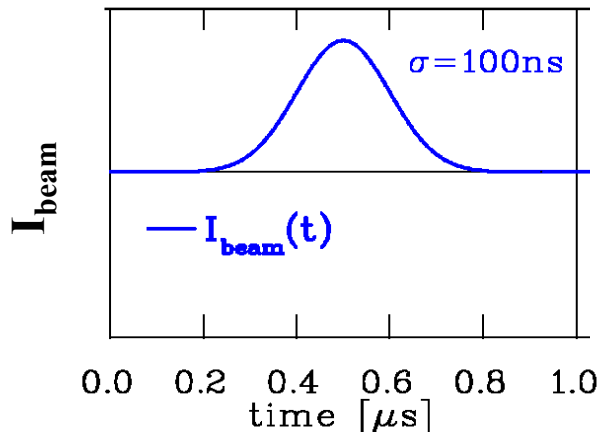

Instrument:
Oscilloscope



Fourier Transformation:

$$\tilde{f}(\omega) = \int_{-\infty}^{\infty} f(t) e^{-i\omega t} dt$$

Frequency domain: Displaying of a voltage as a function of frequency:

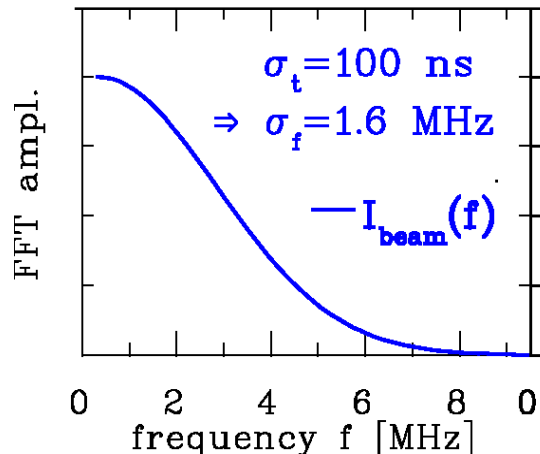

Instrument:
Spectrum Analyzer



Fourier Transformation

- Contains amplitude & phase
- The same information is differently displayed

Pick-Ups for bunched Beams

The image current at the beam pipe is monitored on a high frequency basis
i.e. the ac-part given by the bunched beam.

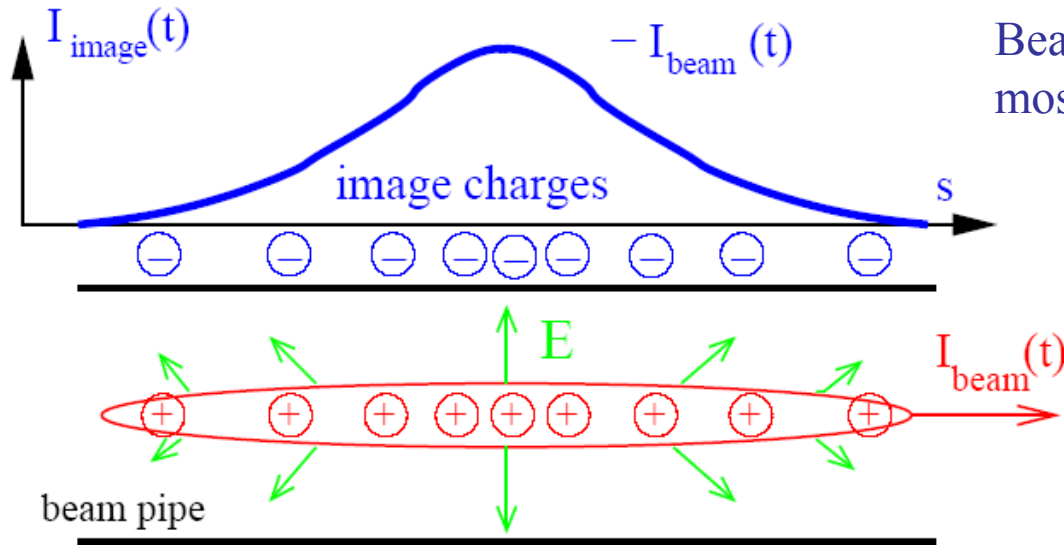

Beam Position Monitor **BPM** is the most frequently used instrument!

For relativistic velocities,
the electric field is transversal:
$$E_{\perp,lab}(t) = \gamma \cdot E_{\perp,rest}(t')$$

Principle of Signal Generation of a BPMs, centered Beam



The image current at the wall is monitored on a high frequency basis i.e. ac-part given by the bunched beam.

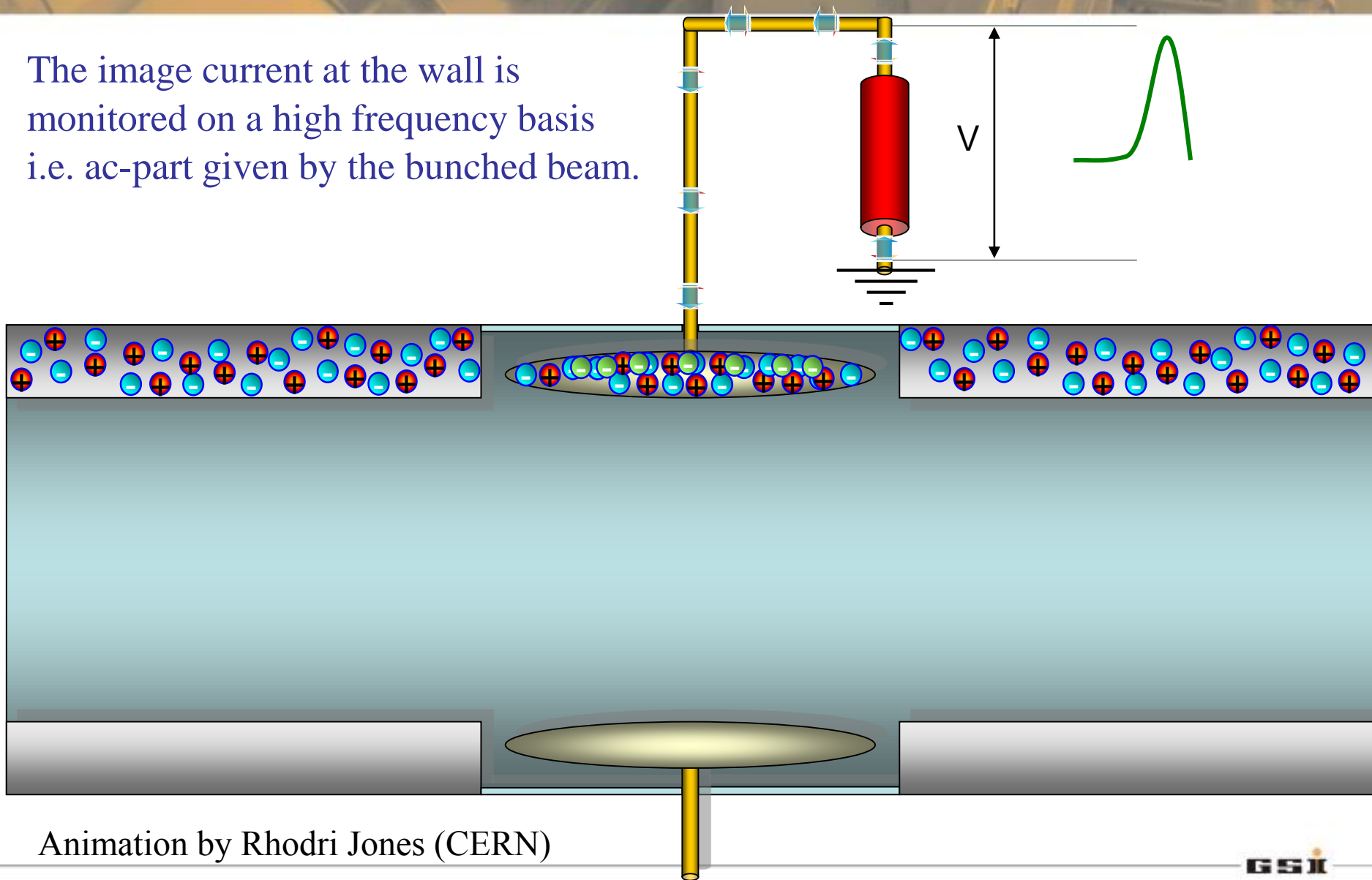

Animation by Rhodri Jones (CERN)

Model for Signal Treatment of capacitive BPMs

The wall current is monitored by a plate or ring inserted in the beam pipe:

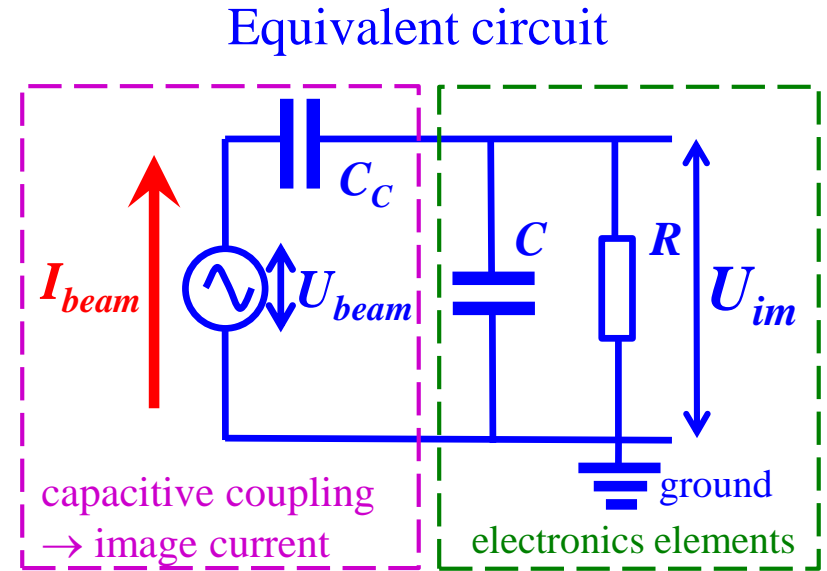
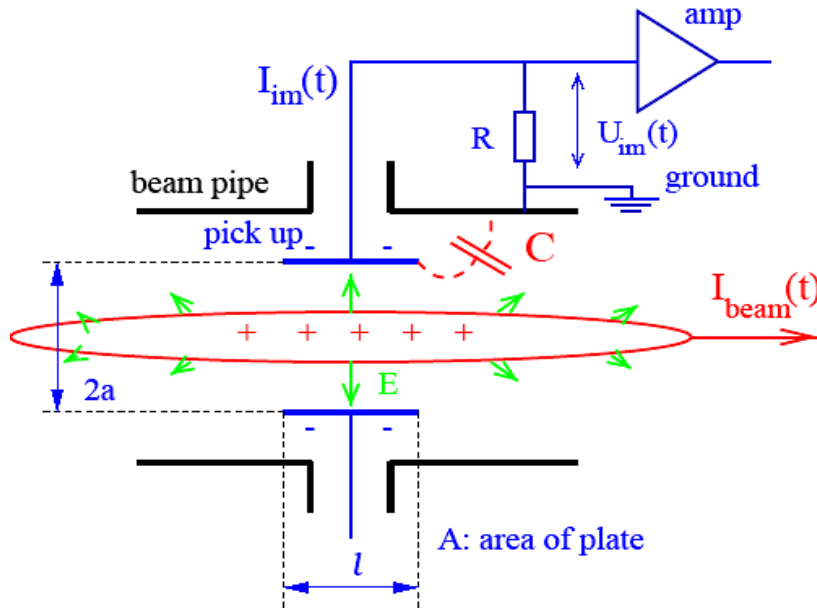

At a resistor R the voltage U_{im} from the image current is measured.

Goal: Connection from beam current to signal strength by transfer impedance $Z_t(\omega)$

in frequency domain: $U_{im}(\omega) = R \cdot I_{im}(\omega) = Z_t(\omega) \cdot I_{beam}(\omega)$

Result:
$$Z_t(\omega) = \frac{A}{2\pi a} \cdot \frac{1}{\beta c} \cdot \frac{1}{C} \cdot \frac{i\omega RC}{1+i\omega RC}$$

geometry
 stray capacitance
 frequency response

Example of Transfer Impedance for Proton Synchrotron

The high-pass characteristic for typical synchrotron BPM:

$$U_{im}(\omega) = Z_t(\omega) \cdot I_{beam}(\omega)$$

$$|Z_t| = \frac{A}{2\pi a} \cdot \frac{1}{\beta c} \cdot \frac{1}{C} \cdot \frac{\omega / \omega_{cut}}{\sqrt{1 + \omega^2 / \omega_{cut}^2}}$$

$$\varphi = \arctan(\omega_{cut} / \omega)$$

Parameter linear-cut BPM at proton synchr.:

$$C = 100 \text{ pF}, l = 10 \text{ cm}, \beta = 50\%$$

$$f_{cut} = \omega / 2\pi = (2\pi RC)^{-1}$$

$$\text{for } R = 50 \Omega \Rightarrow f_{cut} = 32 \text{ MHz}$$

$$\text{for } R = 1 \text{ M}\Omega \Rightarrow f_{cut} = 1.6 \text{ kHz}$$

Large signal strength for long bunches → **high impedance**

Smooth signal transmission important for short bunches → **50 Ω**

Remark: For $\omega \rightarrow 0$ it is $Z_t \rightarrow 0$ i.e. **no** signal is transferred from dc-beams e.g.

- de-bunched beam inside a synchrotron
- for slow extraction through a transfer line

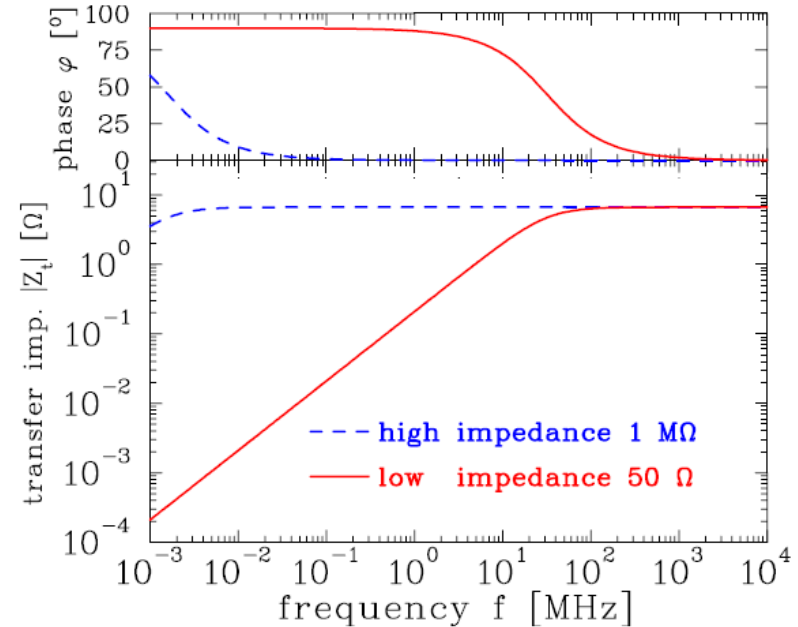

Calculation of Signal Shape (here single Bunch)

The transfer impedance is used in frequency domain! The following is performed:

1. **Start:** Time domain Gaussian function $I_{beam}(t)$ having a width of σ_t

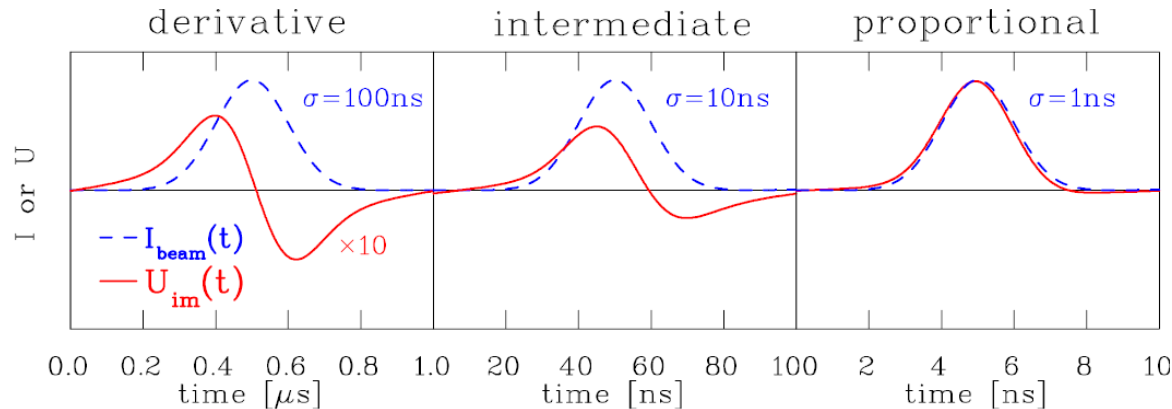

Fourier
trans.

inverse
Fourier
trans.

2. FFT of $I_{beam}(t)$ leads to the frequency domain Gaussian $I_{beam}(f)$ with $\sigma_f = (2\pi\sigma_t)^{-1}$

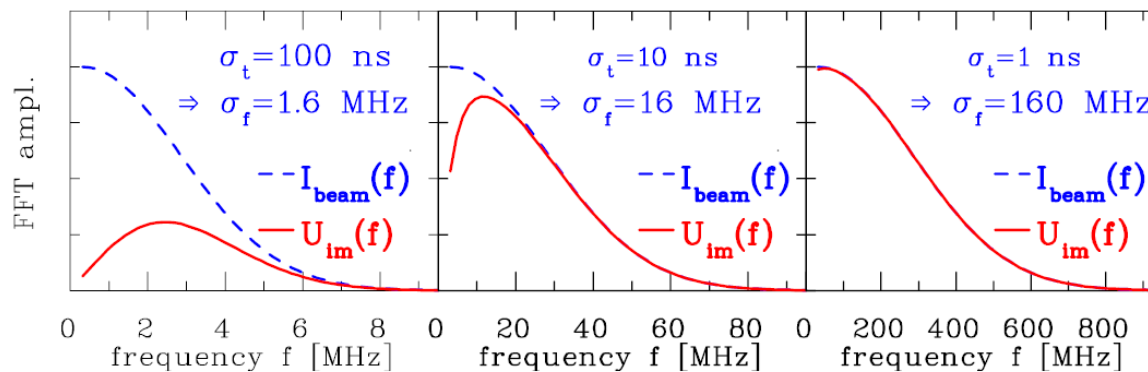

3. **Multiplication** with $Z_t(f)$ with $f_{cut} = 32\text{ MHz}$ leads to $U_{im}(f) = Z_t(f) \cdot I_{beam}(f)$

4. **Inverse FFT** leads to $U_{im}(t)$

Calculation of Signal Shape: repetitive Bunch in a Synchrotron



Synchrotron filled with 8 bunches accelerated with $f_{acc}=1$ MHz
BPM terminated with $R=1$ M $\Omega \Rightarrow f_{acc} \gg f_{cut}$:

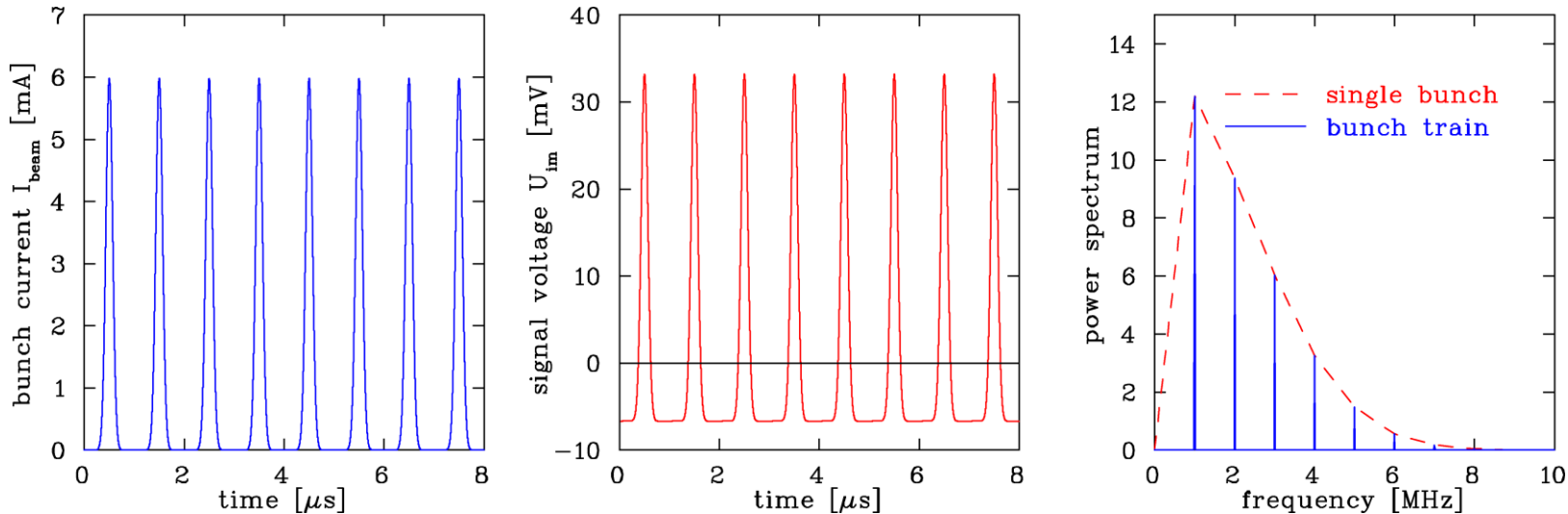

Parameter: $R=1$ M $\Omega \Rightarrow f_{cut}=2$ kHz, $Z_t=5$ Ω , all buckets filled

$C=100$ pF, $l=10$ cm, $\beta=50\%$, $\sigma_t=100$ ns $\Rightarrow \sigma_l=15$ m

- Fourier spectrum is composed of lines separated by acceleration f_{rf}
- Envelope given by single bunch Fourier transformation
- Baseline shift due to ac-coupling

Remark: 1 MHz $< f_{rf} < 10$ MHz \Rightarrow Bandwidth ≈ 100 MHz $= 10 \cdot f_{rf}$ for broadband observation

Calculation of Signal Shape: repetitive Bunch in a Synchrotron



Synchrotron filled with 8 bunches accelerated with $f_{acc}=1$ MHz
BPM terminated with $R=50 \Omega \Rightarrow f_{acc} \ll f_{cut}$:

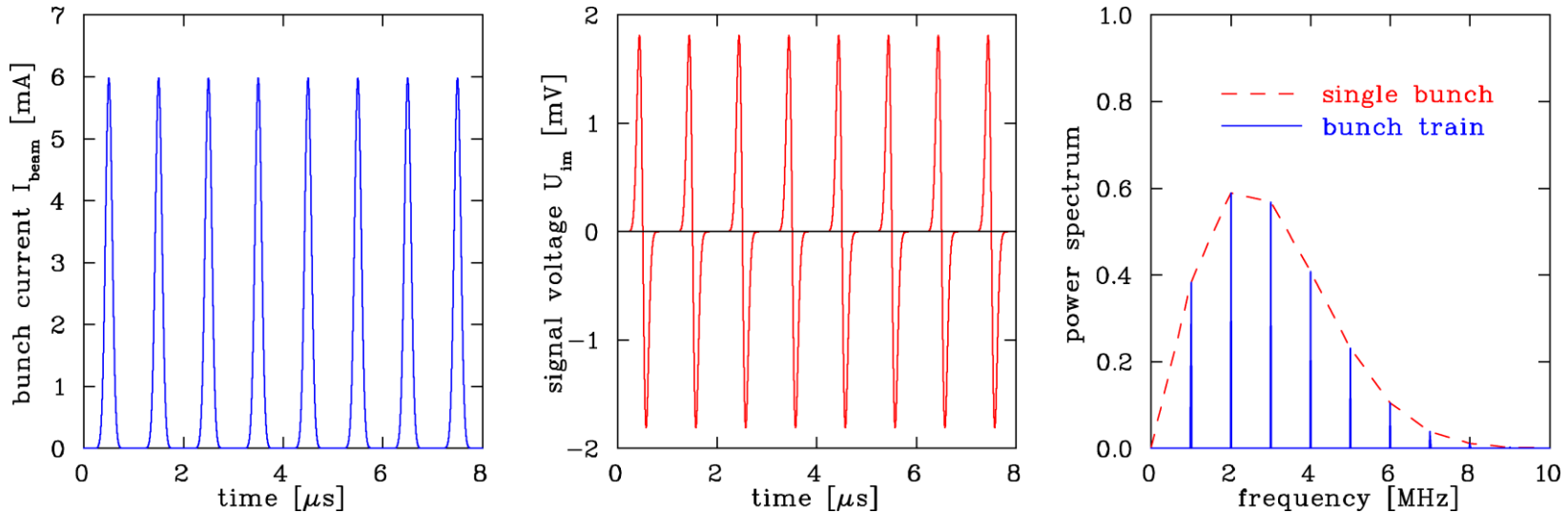

Parameter: $R=50 \Omega \Rightarrow f_{cut}=32$ MHz, all buckets filled

$C=100$ pF, $l=10$ cm, $\beta=50\%$, $\sigma_t=100$ ns $\Rightarrow \sigma_l=15$ m

- Fourier spectrum is concentrated at acceleration harmonics with single bunch spectrum as an envelope.
- Bandwidth up to typically $10 \cdot f_{acc}$

Calculation of Signal Shape: Bunch Train with empty Buckets



Synchrotron during filling: Empty buckets, $R=50 \Omega$:

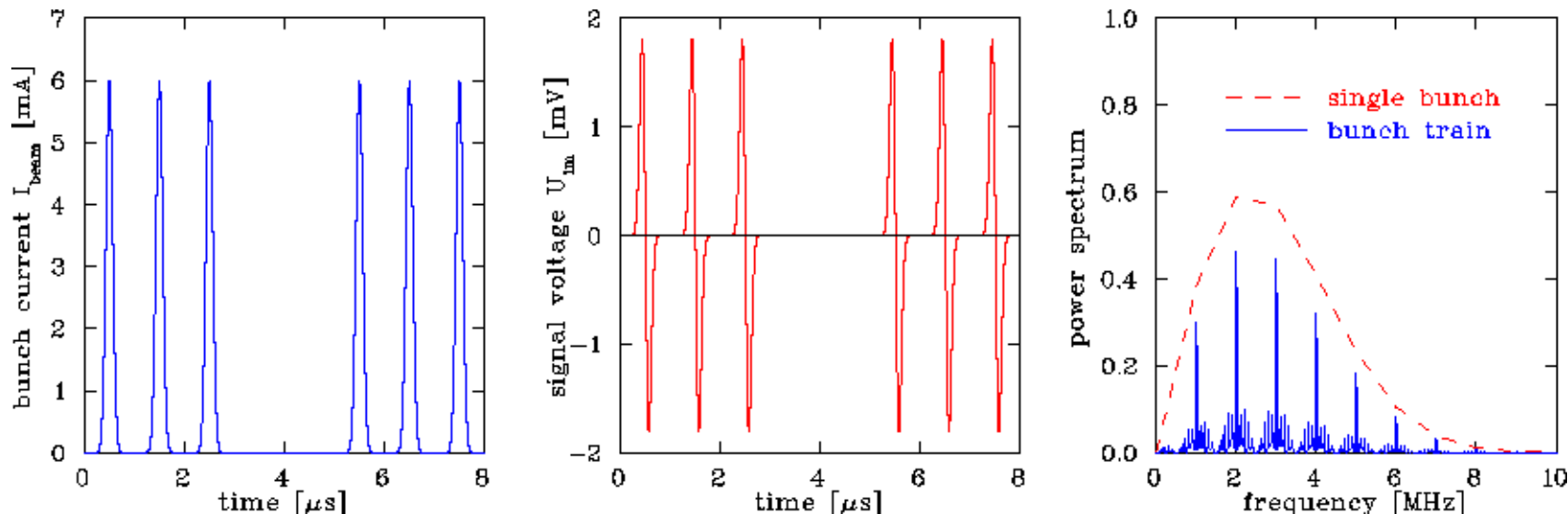

Parameter: $R=50 \Omega \Rightarrow f_{\text{cut}}=32 \text{ MHz}$, 2 empty buckets

$C=100\text{pF}$, $l=10\text{cm}$, $\beta=50\%$, $\sigma_t=100 \text{ ns} \Rightarrow \sigma_l=15\text{m}$

➤ Fourier spectrum is more complex, harmonics are broader due to sidebands

Calculation of Signal Shape: Filtering of Harmonics



Effect of filters, here bandpass:

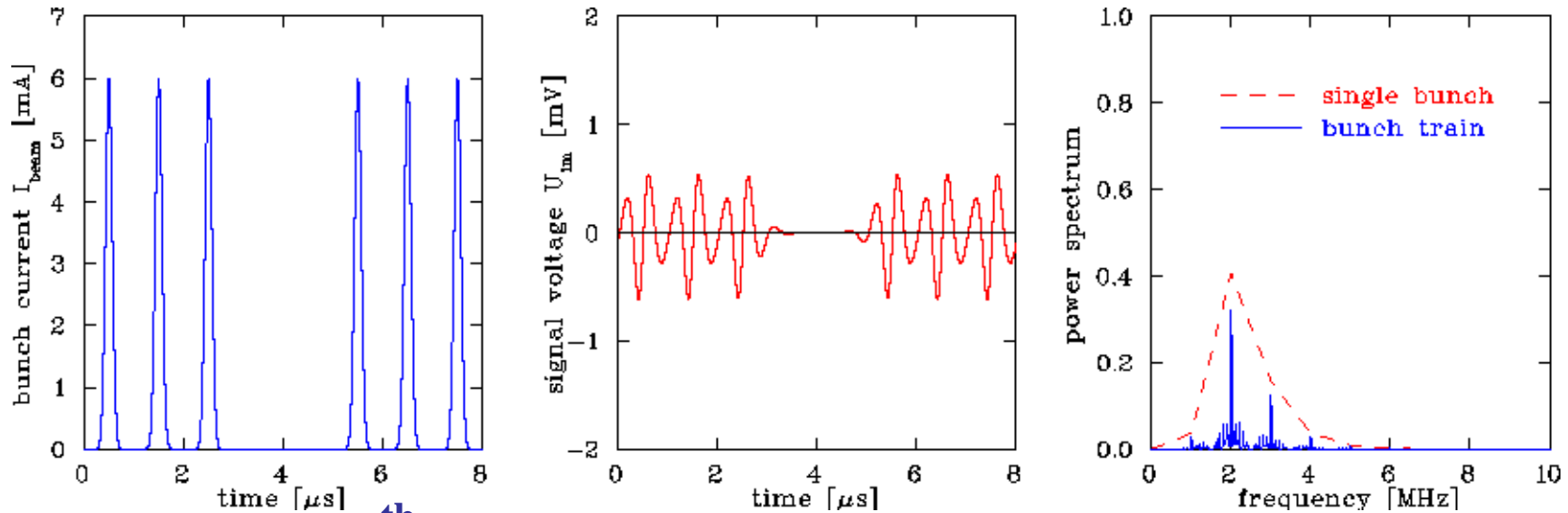

Parameter: $R=50 \Omega$, 4th order Butterworth filter at $f_{cut}=2 \text{ MHz}$

$C=100\text{pF}$, $l=10\text{cm}$, $\beta=50\%$, $\sigma=100 \text{ ns}$

- Ringing due to sharp cutoff
- Other filter types more appropriate

$$\begin{aligned}
 & n^{\text{th}} \text{ order Butterworth filter, math. simple, but } \mathbf{not} \text{ well suited:} \\
 & |H_{low}| = \frac{1}{\sqrt{1 + (\omega / \omega_{cut})^{2n}}} \quad \text{and} \quad |H_{high}| = \frac{(\omega / \omega_{cut})^n}{\sqrt{1 + (\omega / \omega_{cut})^{2n}}} \\
 & H_{filter} = H_{high} \cdot H_{low}
 \end{aligned}$$

Generally: $Z_{tot}(\omega) = H_{cable}(\omega) \cdot H_{filter}(\omega) \cdot H_{amp}(\omega) \cdot \dots \cdot Z_t(\omega)$

Remark: For numerical calculations, time domain filters (FIR and IIR) are more appropriate

Principle of Signal Generation of a BPMs: off-center Beam



The image current at the wall is monitored on a high frequency basis i.e. ac-part given by the bunched beam.

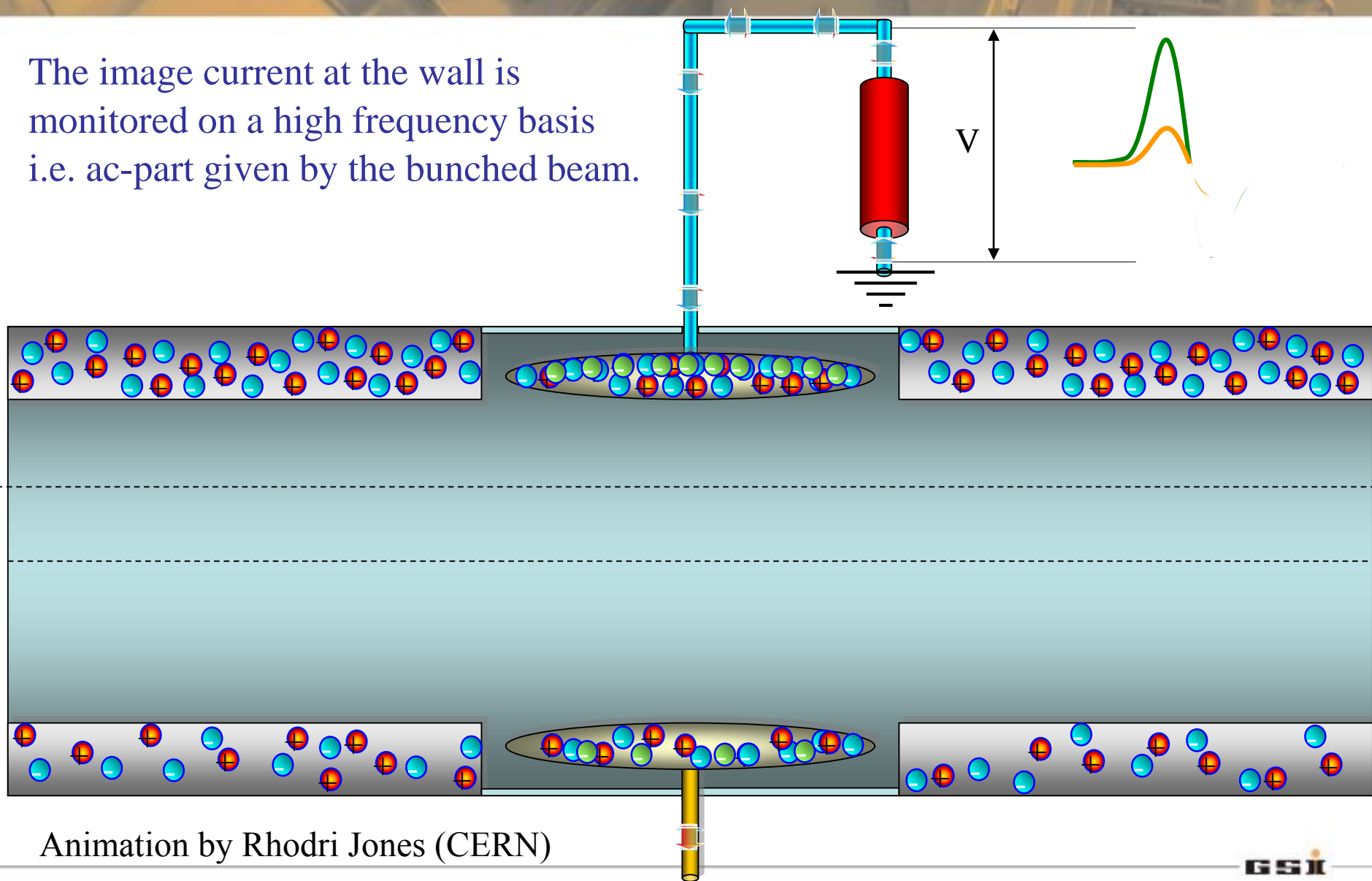

Animation by Rhodri Jones (CERN)

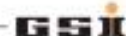

Principle of Position Determination by a BPM

The difference voltage between plates gives the beam's center-of-mass
 → **most frequent application**

‘Proximity’ effect leads to different voltages at the plates:

$$y = \frac{1}{S_y(\omega)} \cdot \frac{U_{up} - U_{down}}{U_{up} + U_{down}} + \delta_y(\omega)$$

$$\equiv \frac{1}{S_y} \cdot \frac{\Delta U_y}{\Sigma U_y} + \delta_y$$

$$x = \frac{1}{S_x(\omega)} \cdot \frac{U_{right} - U_{left}}{U_{right} + U_{left}} + \delta_x(\omega)$$

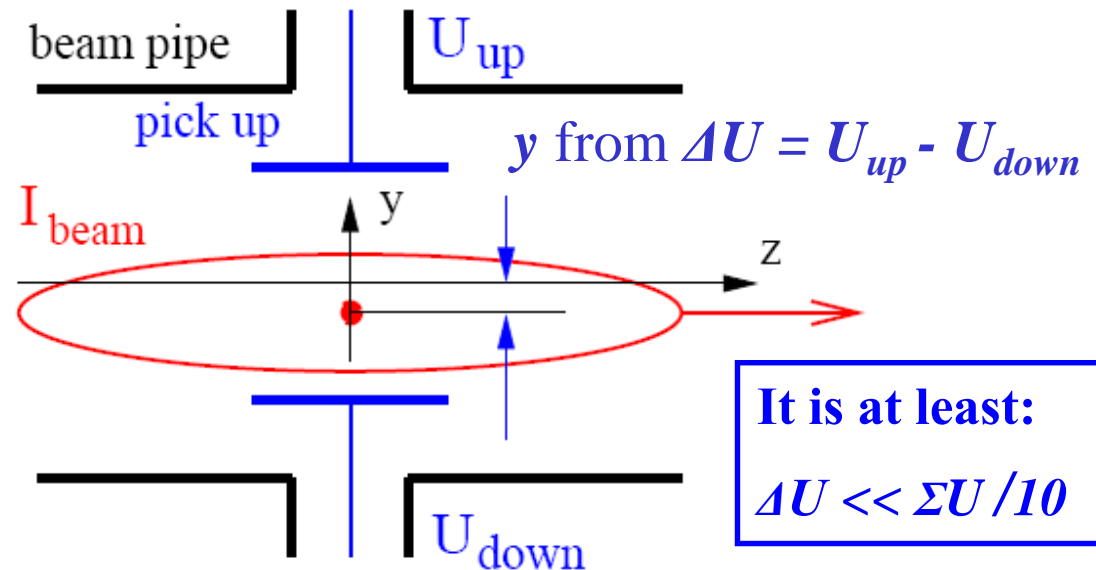

$S(\omega, x)$ is called **position sensitivity**, sometimes the inverse is used $k(\omega, x) = 1/S(\omega, x)$

S is a geometry dependent, non-linear function, which have to be optimized

Units: $S = [\%/mm]$ and sometimes $S = [dB/mm]$ or $k = [mm]$.

Typical desired position resolution: $\Delta x \approx 0.3 \dots 0.1 \cdot \sigma_x$ of beam width

The Artist View of a BPM

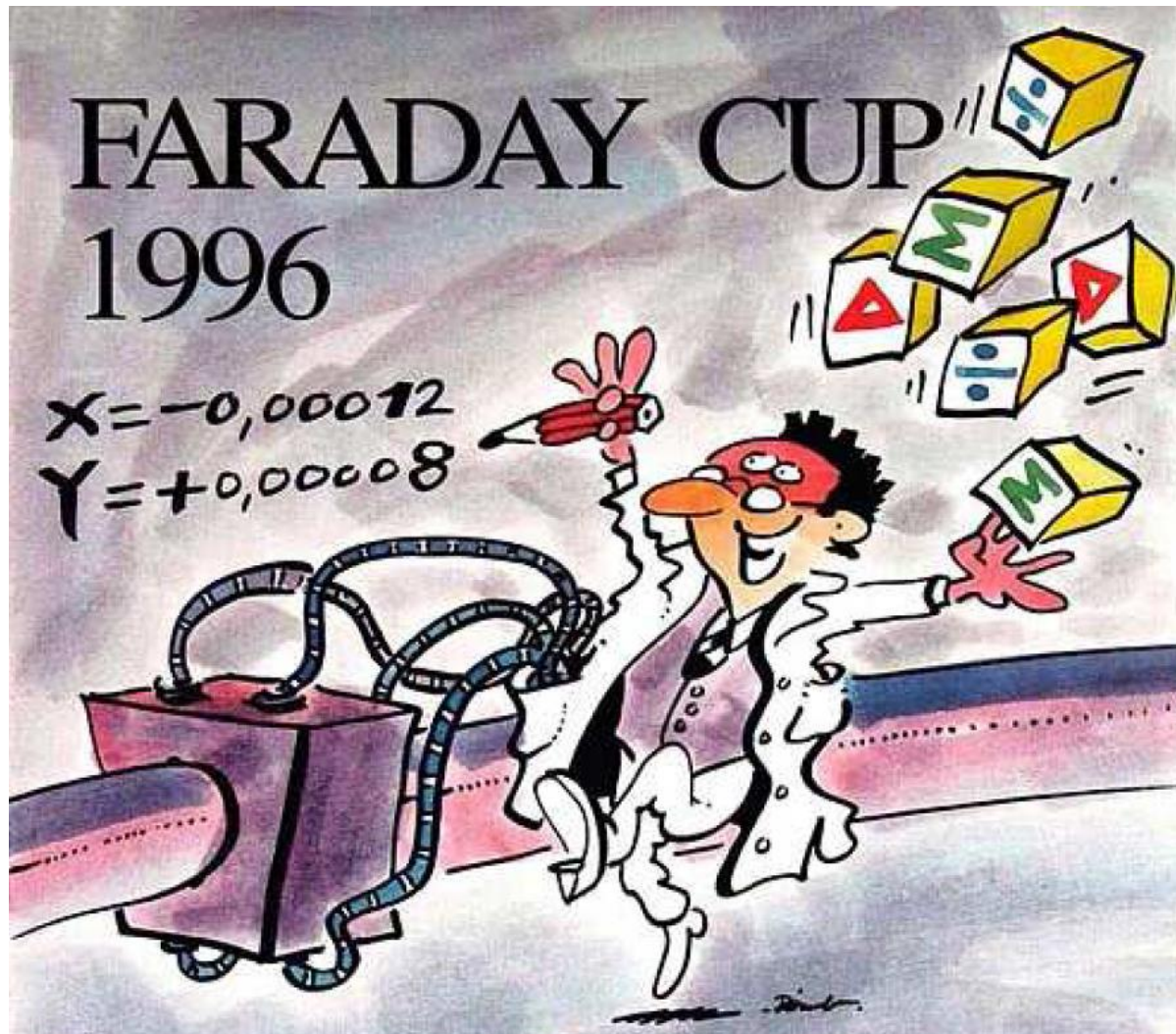

Outline:

- Signal generation → transfer impedance
- Capacitive *button* BPM for high frequencies
used at most proton LINACs and electron accelerators
- Capacitive *linear-cut* BPM for low frequencies
- Electronics for position evaluation
- BPMs for measurement of closed orbit, tune and further lattice functions
- Summary

2-dim Model for a Button BPM

‘Proximity effect’: larger signal for closer plate

Ideal 2-dim model: Cylindrical pipe → image current density via ‘image charge method’ for ‘pencil’ beam:

$$j_{im}(\phi) = \frac{I_{beam}}{2\pi a} \cdot \left(\frac{a^2 - r^2}{a^2 + r^2 - 2ar \cdot \cos(\phi - \theta)} \right)$$

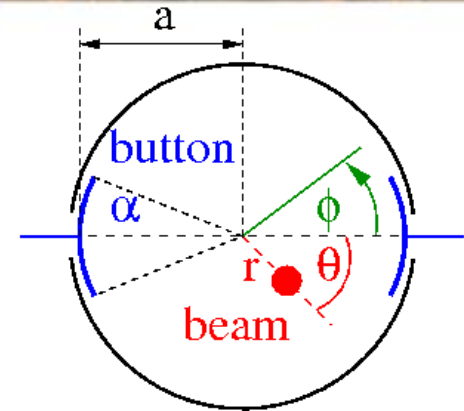
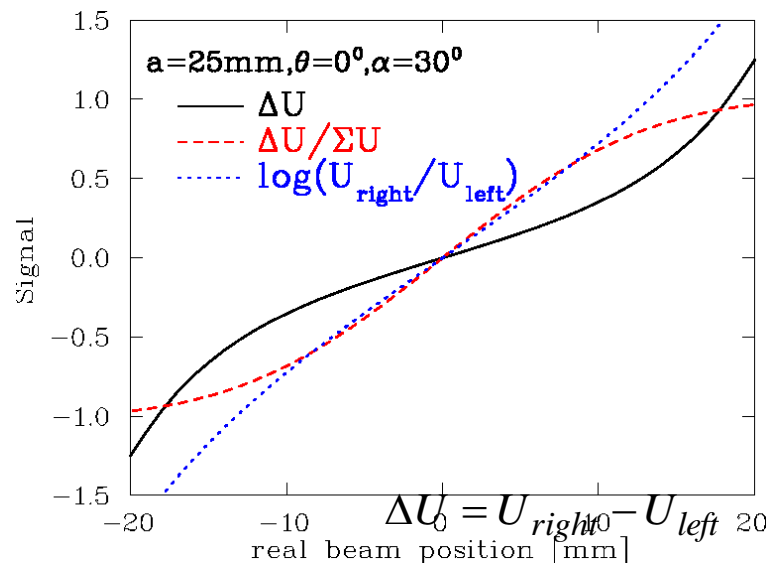
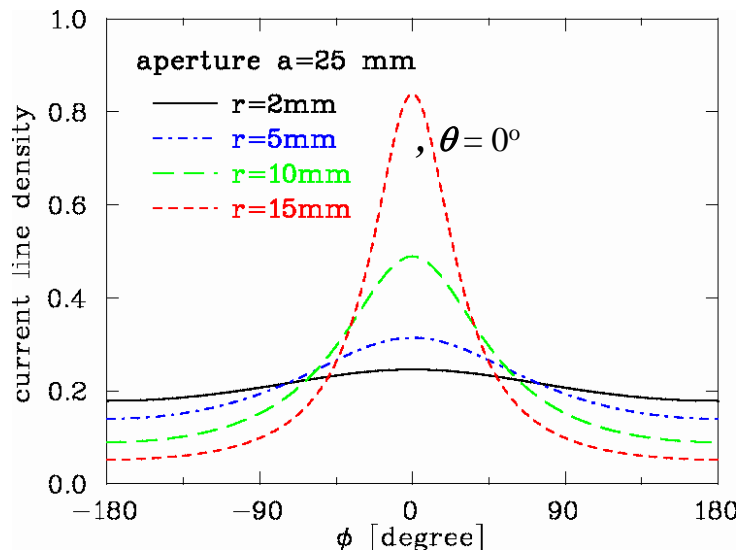

Image current: Integration of finite BPM size: $I_{im} = a \cdot \int_{-\alpha/2}^{\alpha/2} j_{im}(\phi) d\phi$



2-dim Model for a Button BPM

Ideal 2-dim model: Non-linear behavior and hor-vert coupling:

Sensitivity S is converts signal to position $x = \frac{1}{S} \cdot \frac{\Delta U}{\Sigma U}$

with S [%/mm] or [dB/mm]

i.e. S is the derivative of the curve $S_x = \frac{\partial(\frac{\Delta U}{\Sigma U})}{\partial x}$, here $S_x = S_x(x, y)$ i.e. non-linear.

For this example: center part $S=7.4\%/mm \Leftrightarrow k=1/S=14mm$

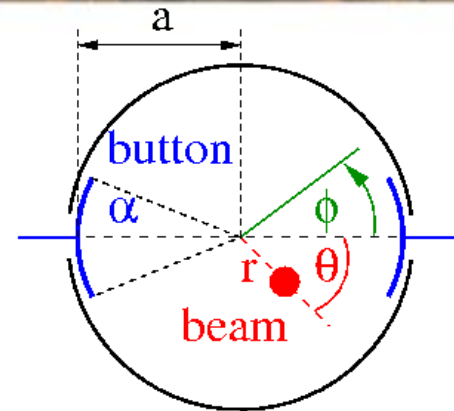

Horizontal plane

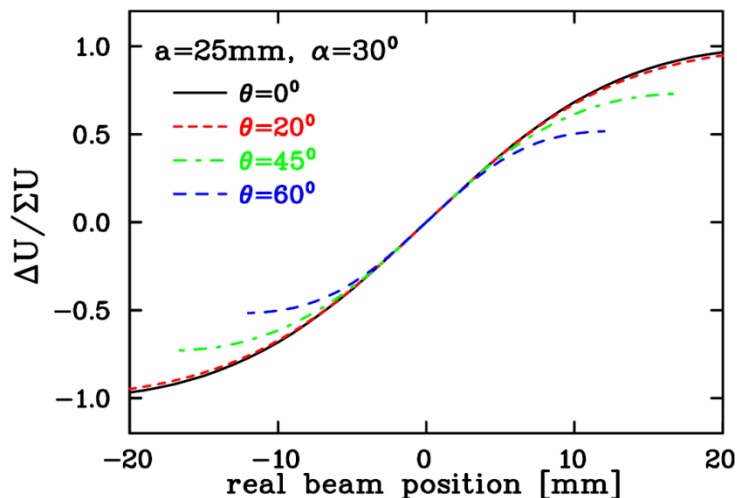

Position Map

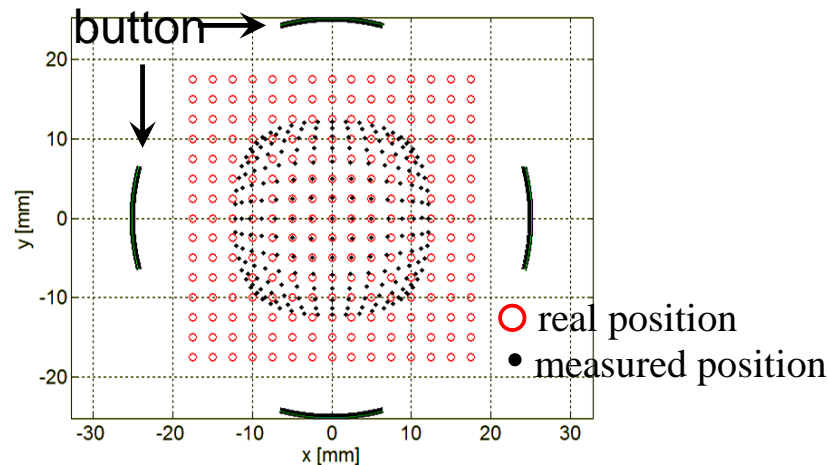

Estimation of finite Beam Size Effect for Button BPM



Ideal 2-dim model:

Due to the non-linearity, the beam size enters in the position reading.

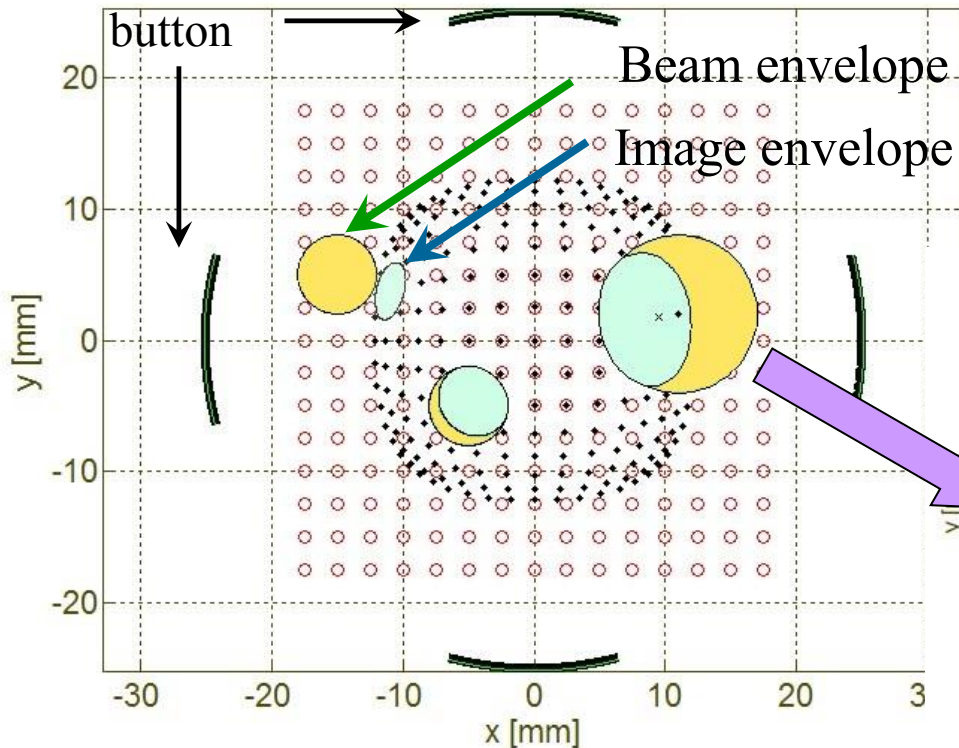

Finite beam size:

- Calculation of signal response at different location
 - 'Averaging' of image position
- ⇒ **Cannot be corrected !**

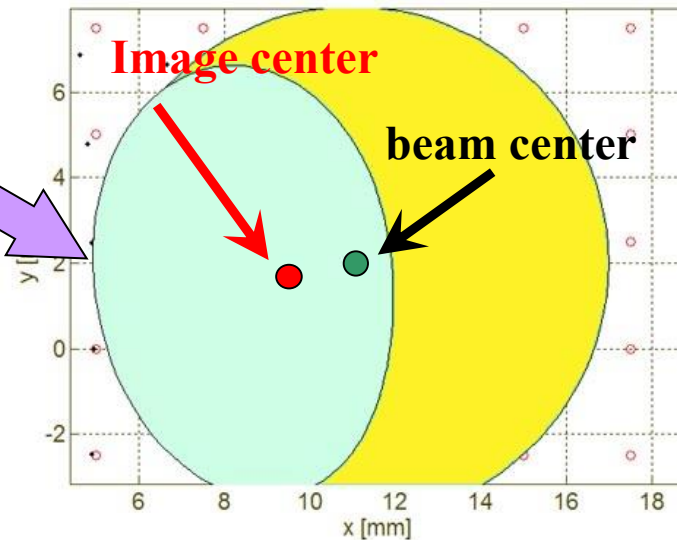

Remark: For most LINACs: Linearity is less important, because beam has to be centered
Position correction as feed-forward for next macro-pulse.

Button BPM Realization

LINACs, e⁻-synchrotrons: $100 \text{ MHz} < f_{rf} < 3 \text{ GHz} \rightarrow$ bunch length \approx BPM length

$\rightarrow 50 \Omega$ signal path to prevent reflections

Example: LHC-type inside cryostat:

$\varnothing 24 \text{ mm}$, half aperture $a=25 \text{ mm}$, $C=8 \text{ pF}$

$\Rightarrow f_{cut}=400 \text{ MHz}$, $Z_t = 1.3 \Omega$ above f_{cut}

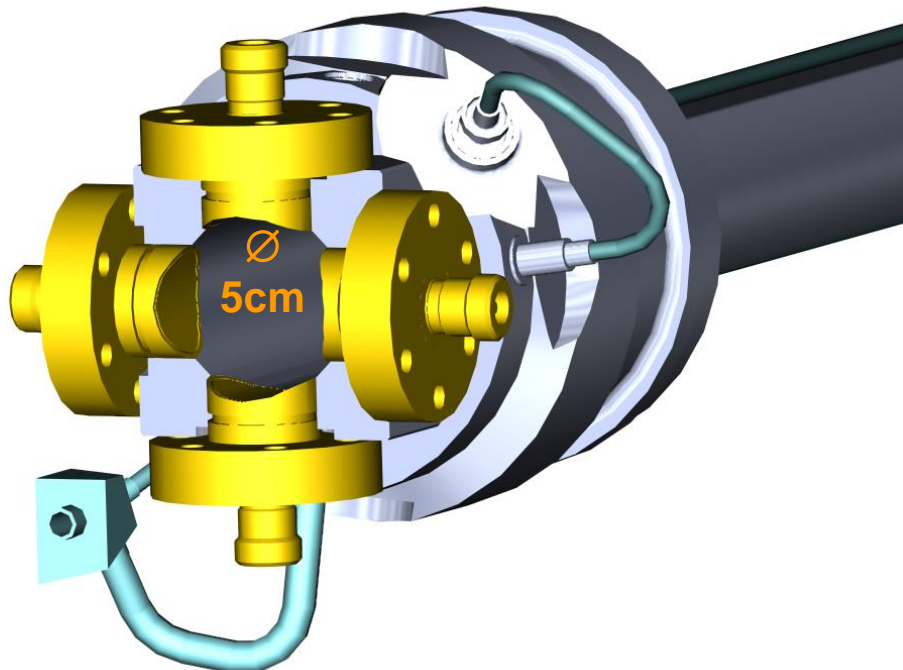

Courtesy C. Boccard (CERN)

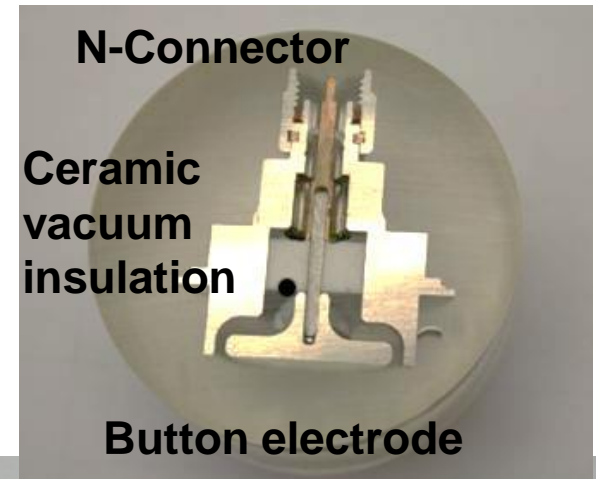

$\varnothing 24 \text{ mm}$



Button BPM at Synchrotron Light Sources

Due to synchrotron radiation, the button insulation might be destroyed
 ⇒ buttons only in vertical plane possible ⇒ increased non-linearity

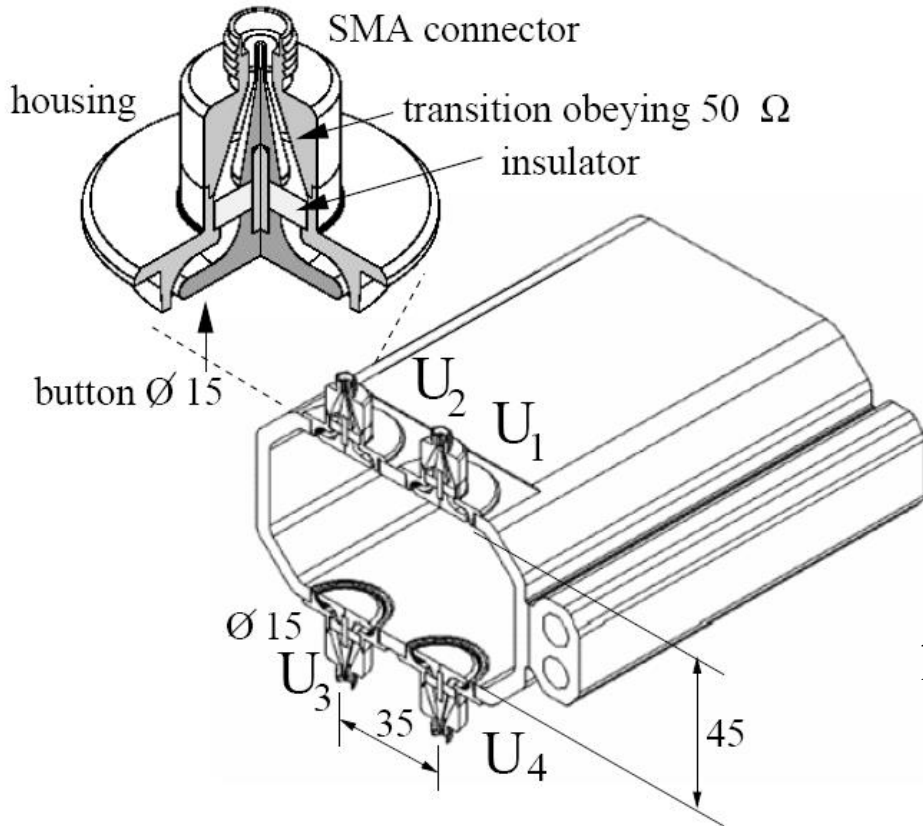

PEP-realization: N. Kurita et al., PAC 1995

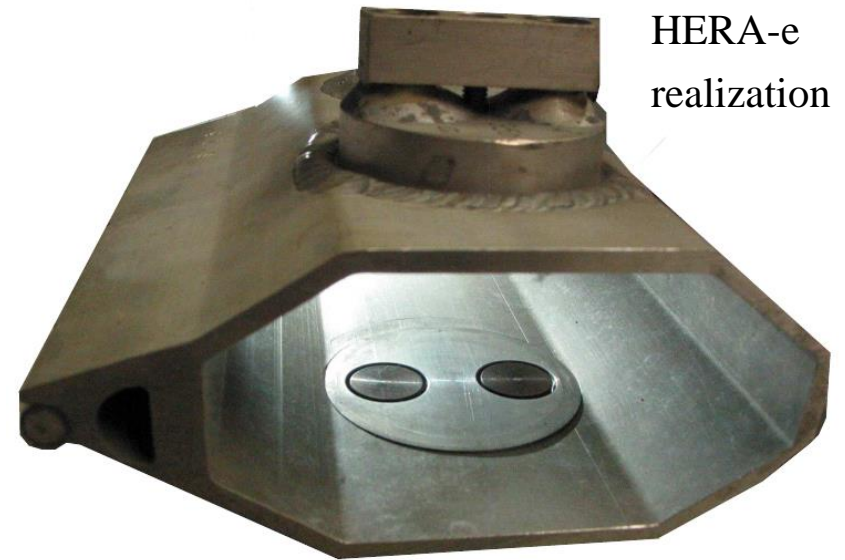

HERA-e realization

$$\text{horizontal: } x = \frac{1}{S_x} \cdot \frac{(U_1 + U_4) - (U_2 + U_3)}{U_1 + U_2 + U_3 + U_4}$$

$$\text{vertical: } y = \frac{1}{S_y} \cdot \frac{(U_1 + U_2) - (U_3 + U_4)}{U_1 + U_2 + U_3 + U_4}$$

Simulations for Button BPM at Synchrotron Light Sources

Example: Simulation for ALBA light source for 72 x 28 mm² chamber

Optimization: horizontal distance and size of buttons

from A.A. Nosych et al., IBIC'14

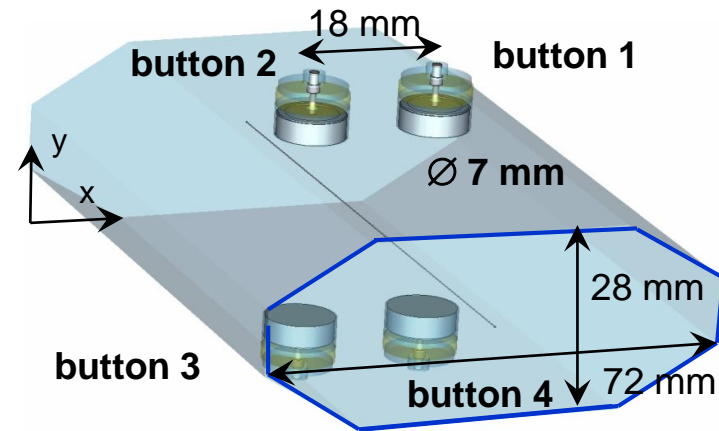
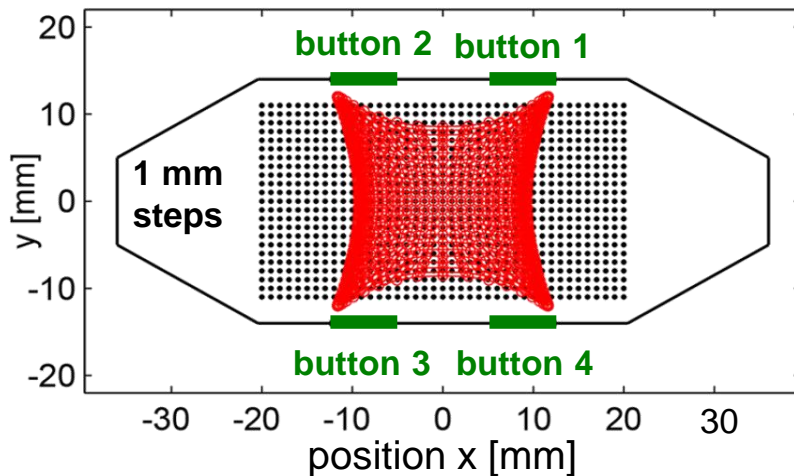
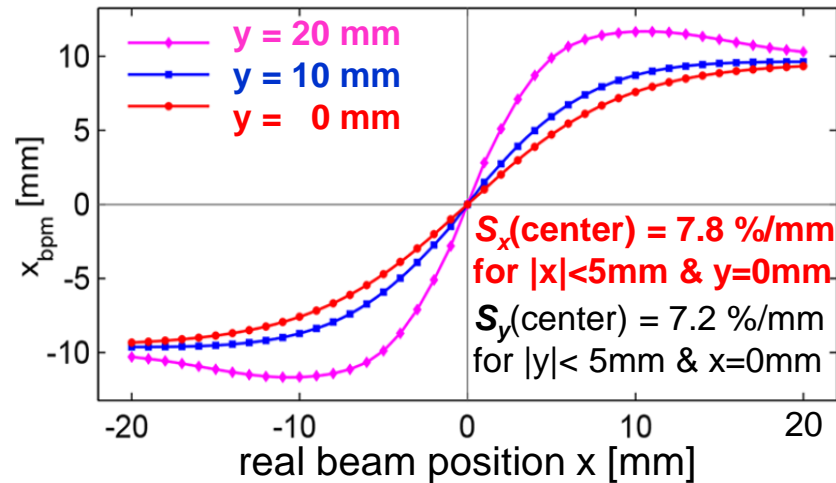
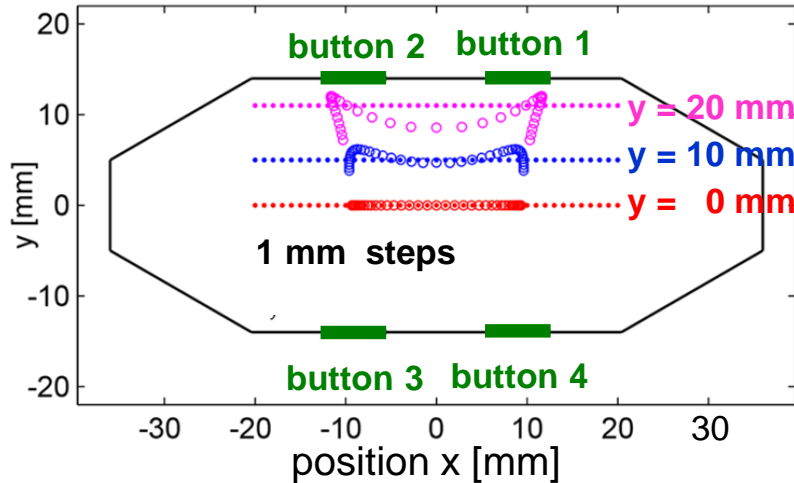

Result: non-linearity and xy -coupling occur in dependence of button size and position

Outline:

- Signal generation → transfer impedance
- Capacitive *button* BPM for high frequencies
used at most proton LINACs and electron accelerators
- Capacitive *linear-cut* BPM for low frequencies
used at most proton synchrotrons due to linear position reading
- Electronics for position evaluation
- BPMs for measurement of closed orbit, tune and further lattice functions
- Summary

Linear-cut BPM for Proton Synchrotrons

Frequency range: $1 \text{ MHz} < f_{rf} < 100 \text{ MHz} \Rightarrow \text{bunch-length} \gg \text{BPM length}$.

Signal is proportional to actual plate length:

$$l_{\text{right}} = (a + x) \cdot \tan \alpha, \quad l_{\text{left}} = (a - x) \cdot \tan \alpha$$

$$\Rightarrow x = a \cdot \frac{l_{\text{right}} - l_{\text{left}}}{l_{\text{right}} + l_{\text{left}}}$$

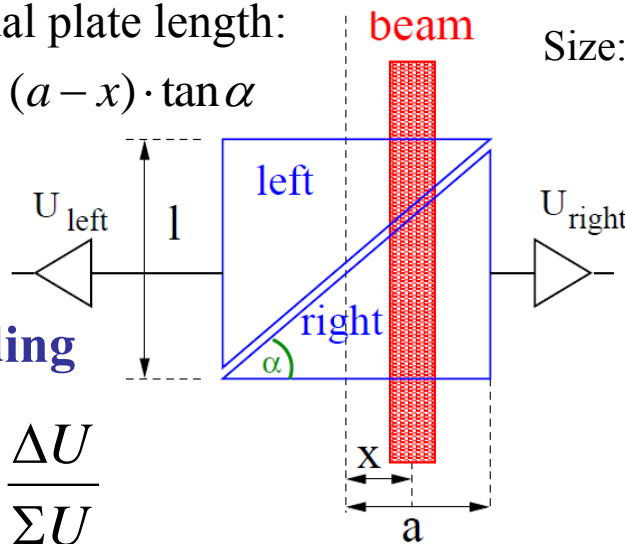

Size: 200x70 mm²

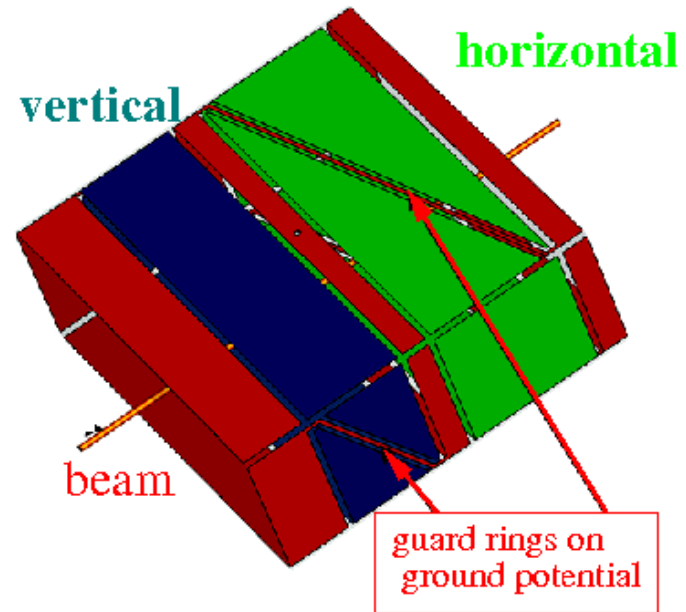

In ideal case: linear reading

$$x = a \cdot \frac{U_{\text{right}} - U_{\text{left}}}{U_{\text{right}} + U_{\text{left}}} \equiv a \cdot \frac{\Delta U}{\Sigma U}$$

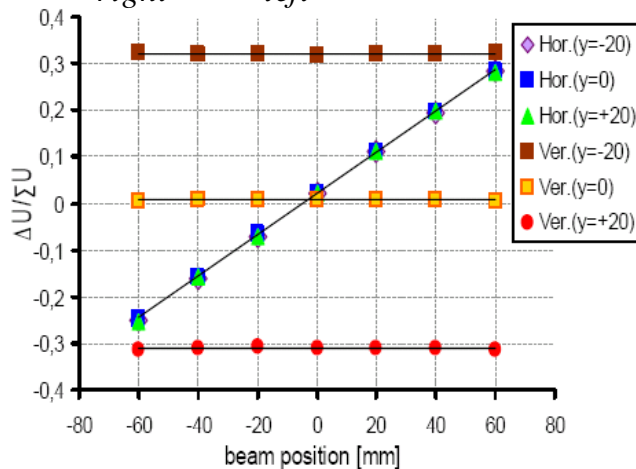

Linear-cut BPM:

Advantage: Linear, i.e. constant position sensitivity S
 \Leftrightarrow no beam size dependence

Disadvantage: Large size, complex mechanics
 high capacitance

Technical Realization of a linear-cut BPM

Technical realization at HIT synchrotron of 46 m length for 7 MeV/u \rightarrow 440 MeV/u
BPM clearance: 180x70 mm², standard beam pipe diameter: 200 mm.

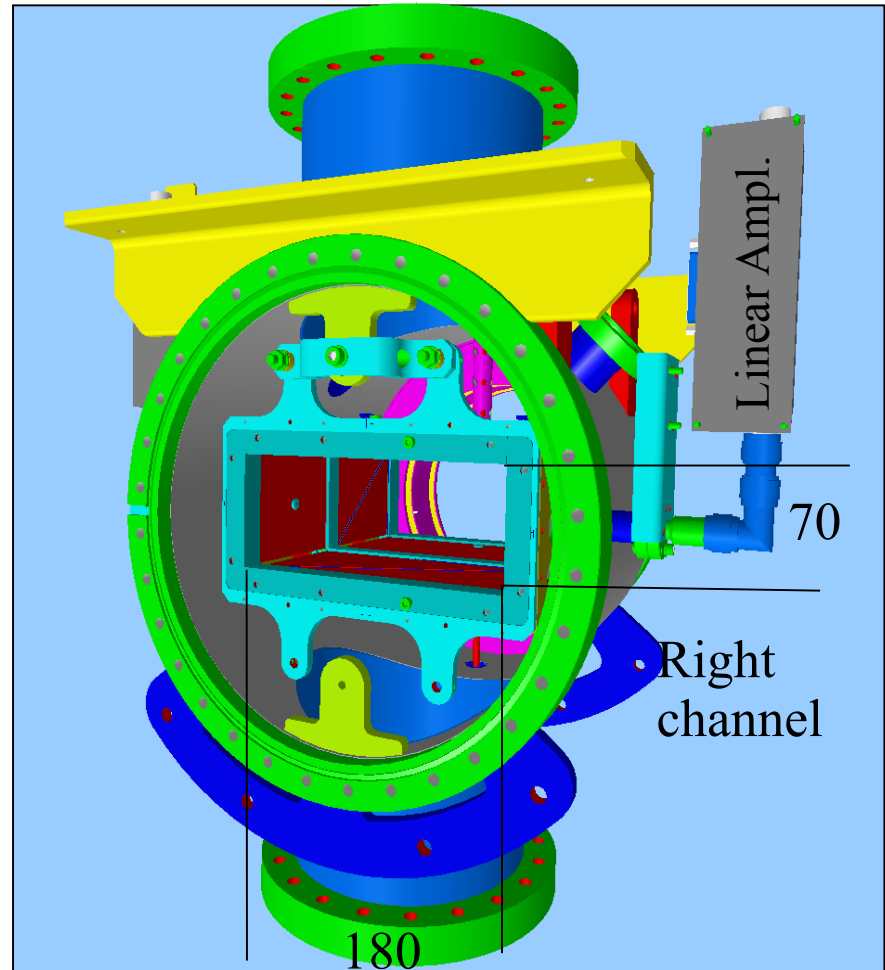
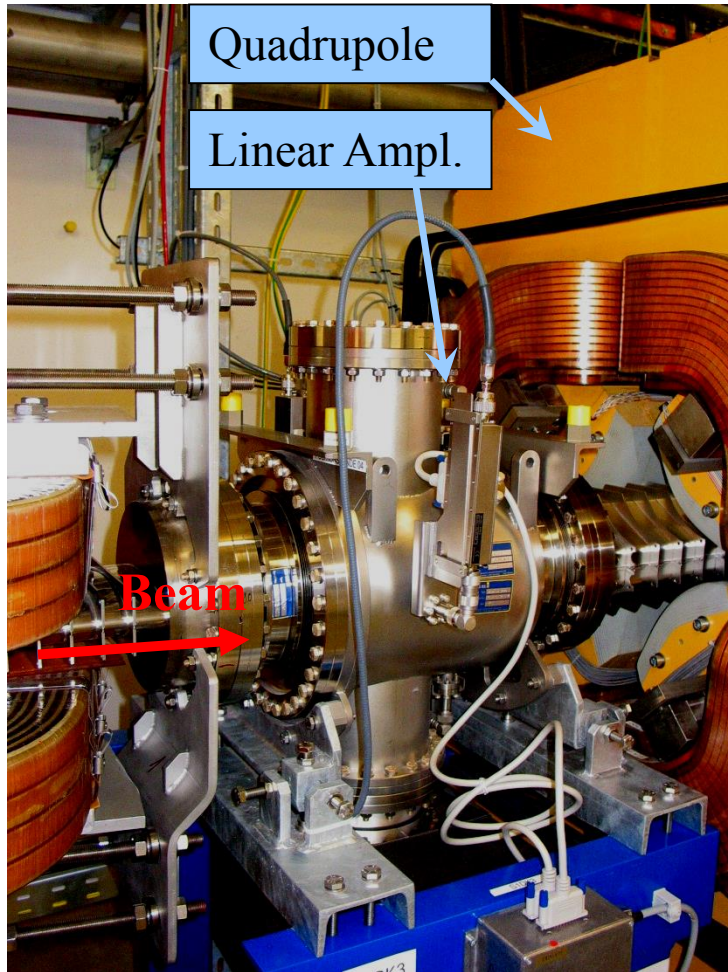

Technical Realization of a linear-cut BPM

Technical realization at HIT synchrotron of 46 m length for 7 MeV/u \rightarrow 440 MeV/u
BPM clearance: 180x70 mm², standard beam pipe diameter: 200 mm.

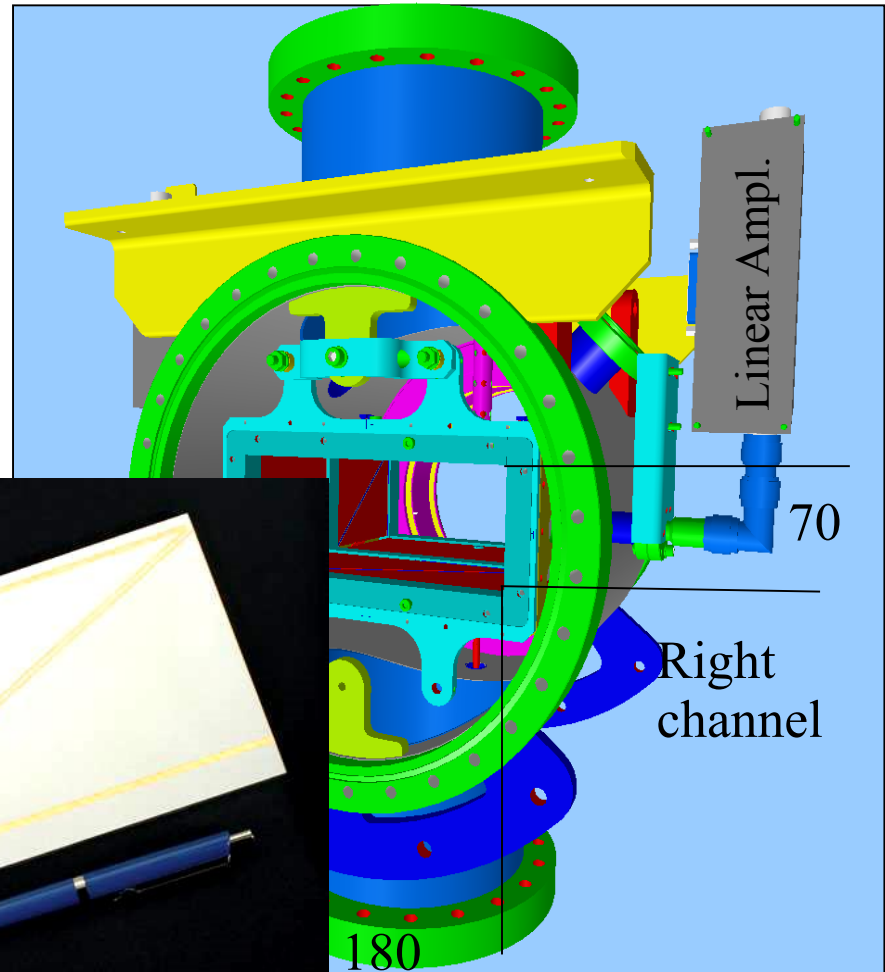
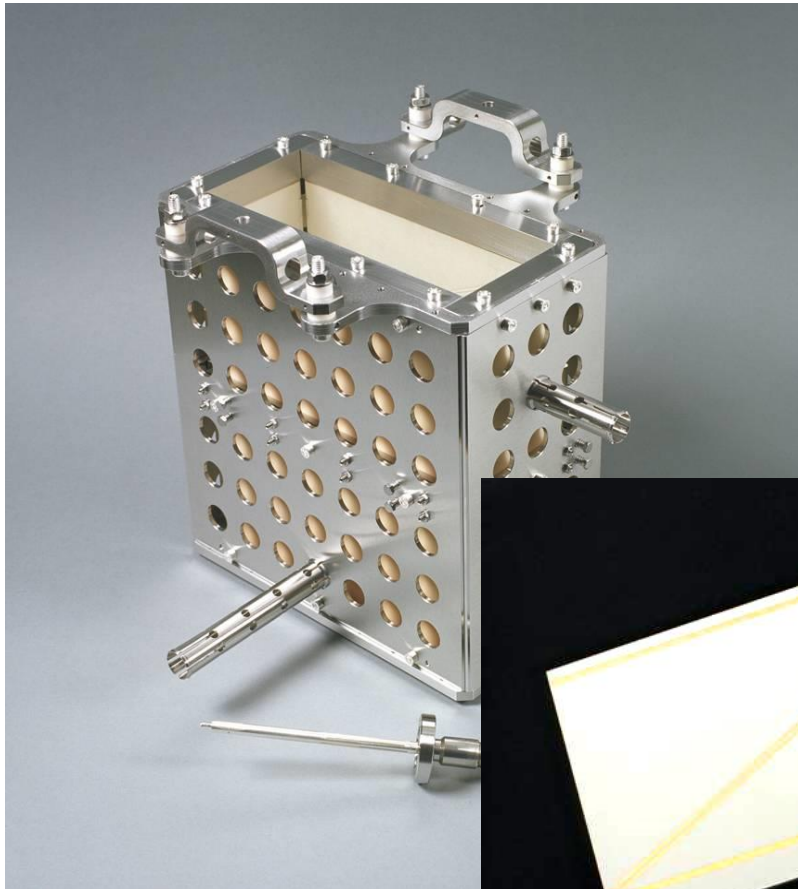

Comparison linear-cut and Button BPM

	Linear-cut BPM	Button BPM
Precaution	Bunches longer than BPM	Bunch length comparable to BPM
BPM length (typical)	10 to 20 cm length per plane	∅1 to 5 cm per button
Shape	Rectangular or cut cylinder	Orthogonal or planar orientation
Bandwidth (typical)	0.1 to 100 MHz	100 MHz to 5 GHz
Coupling	1 MΩ or ≈1 kΩ (transformer)	50 Ω
Cutoff frequency (typical)	0.01... 10 MHz (C=30...100pF)	0.3... 1 GHz (C=2...10pF)
Linearity	Very good, no x-y coupling	Non-linear, x-y coupling
Sensitivity	Good, care: plate cross talk	Good, care: signal matching
Usage	At proton synchrotrons, $f_{rf} < 10$ MHz	All electron acc., proton Linacs, $f_{rf} > 100$ MHz

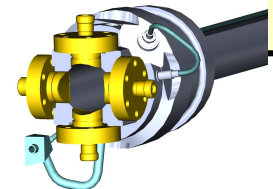
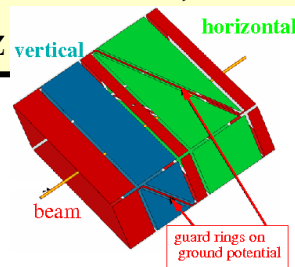

Remark: Other types are also some time used: e.g. wall current monitors, inductive antenna, BPMs with external resonator, cavity BPM, slotted wave-guides for stochastic cooling etc.

Outline:

- **Signal generation → transfer impedance**
- **Capacitive *button* BPM for high frequencies**
used at most proton LINACs and electron accelerators
- **Capacitive *linear-cut* BPM for low frequencies**
used at most proton synchrotrons due to linear position reading
- **Electronics for position evaluation**
analog signal conditioning to achieve small signal processing
- **BPMs for measurement of closed orbit, tune and further lattice functions**
- **Summary**

Broadband Signal Processing

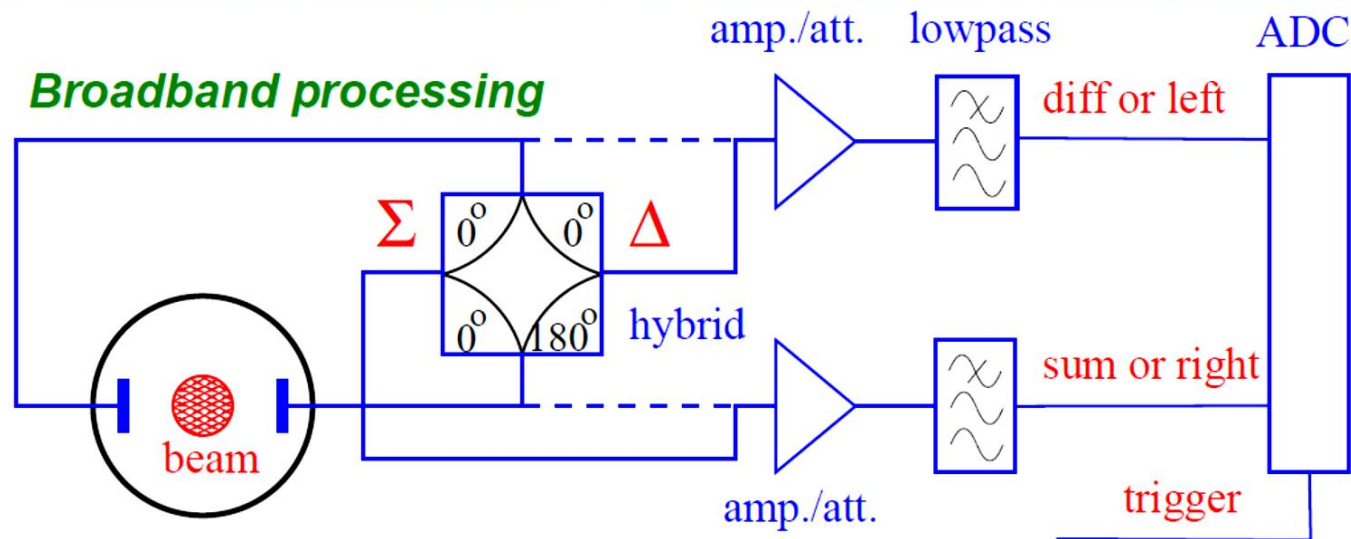

- Hybrid or transformer close to beam pipe for analog ΔU & ΣU generation or U_{left} & U_{right}
- Attenuator/amplifier
- Filter to get the wanted harmonics and to suppress stray signals
- ADC: digitalization \rightarrow followed by calculation of $\Delta U / \Sigma U$

Advantage: Bunch-by-bunch observation possible, versatile post-processing possible

Disadvantage: Resolution down to $\approx 100 \mu\text{m}$ for shoe box type, i.e. $\approx 0.1\%$ of aperture, resolution is worse than narrowband processing, see below

Challenge: Precise analog electronics with very low drift of amplification etc.

General: Noise Consideration

1. Signal voltage given by: $U_{im}(f) = Z_t(f) \cdot I_{beam}(f)$
2. Position information from voltage difference: $x = 1/S \cdot \Delta U / \Sigma U$
3. Thermal noise voltage given by: $U_{noise}(R, \Delta f) = \sqrt{4k_B \cdot T \cdot R \cdot \Delta f}$

1 Signal-to-noise $\Delta U_{im}/U_{noise}$ is influenced by:

- Input signal amplitude
 - Thermal noise from amplifiers etc.
 - Bandwidth Δf
- ⇒ Restriction of frequency width
as the power is concentrated at harm. nf_{rf}

Example: GSI-LINAC with $f_{rf}=36$ MHz

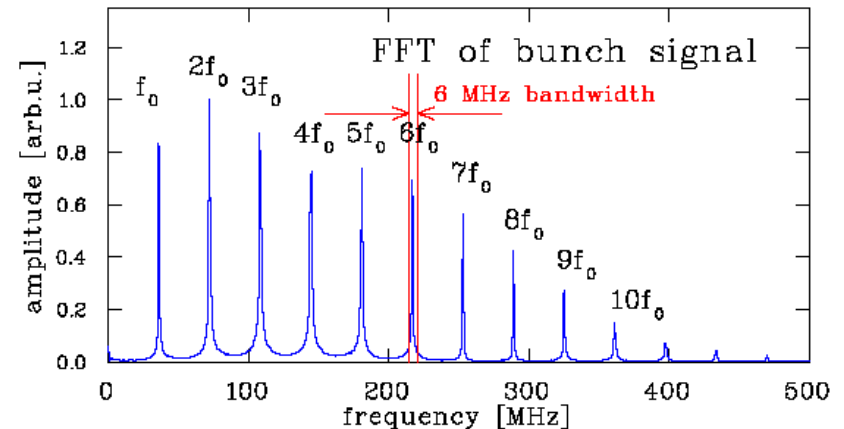
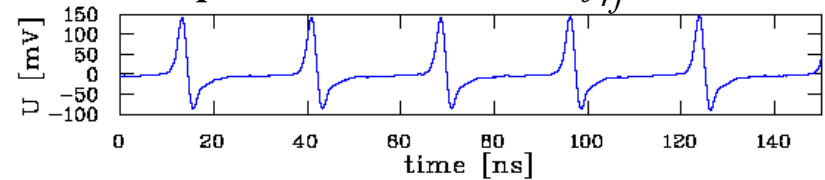

Narrowband Processing for improved Signal-to-Noise

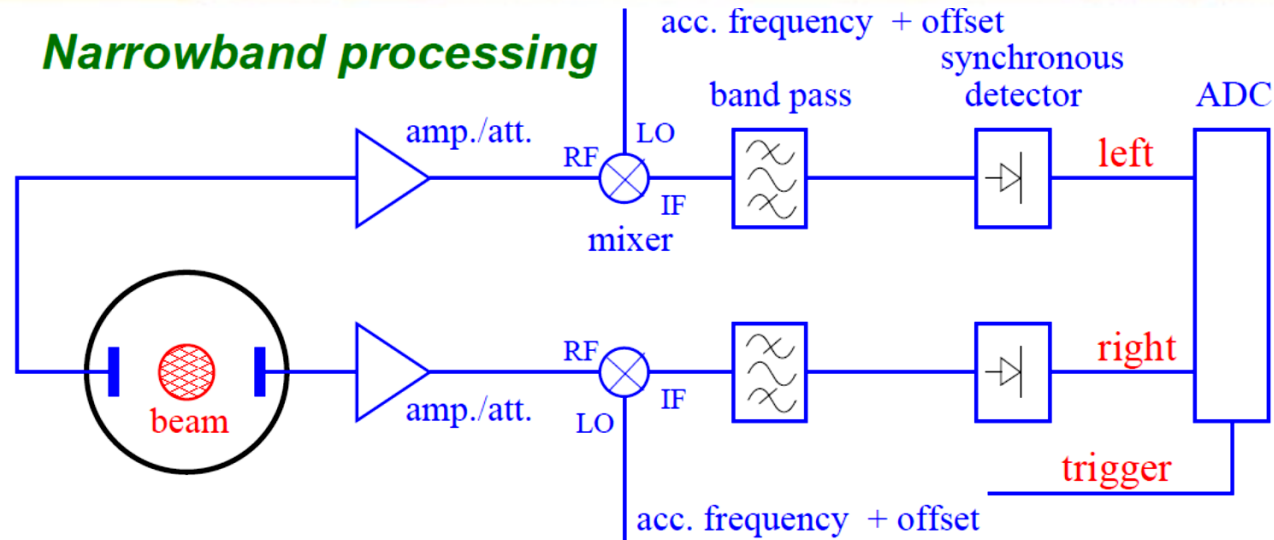

Narrowband processing equals heterodyne receiver (e.g. AM-radio or spectrum analyzer)

- Attenuator/amplifier
- Mixing with accelerating frequency $f_{rf} \Rightarrow$ signal with difference frequency
- Bandpass filter of the mixed signal (e.g at 10.7 MHz)
- Rectifier: synchronous detector
- ADC: digitalization \rightarrow followed calculation of $\Delta U / \Sigma U$

} Digital
correspondence:
I/Q demodulation

Advantage: spatial resolution about 100 time better than broadband processing

Disadvantage: No turn-by-turn diagnosis, due to mixing = 'long averaging time'

Comparison: Filtered Signal ↔ Single Turn



Example: GSI Synchr.: U^{73+} , $E_{inj}=11.5$ MeV/u \rightarrow 250 MeV/u within 0.5 s, 10^9 ions

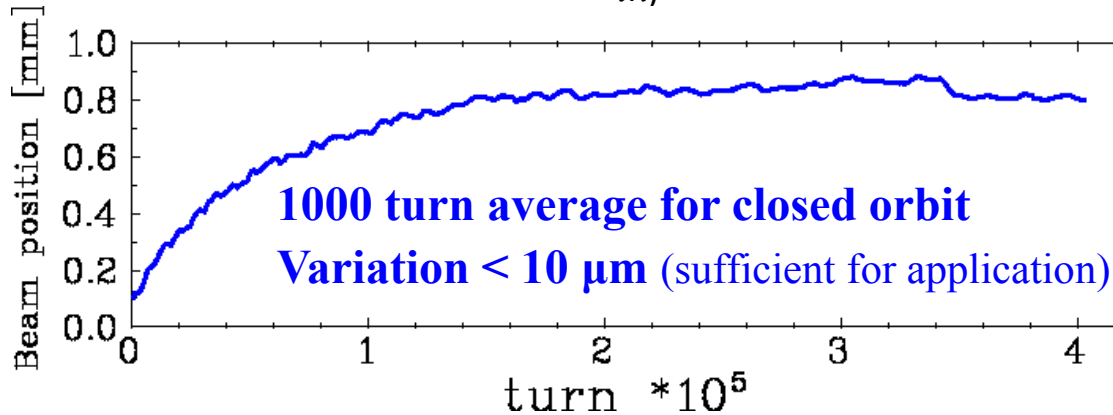

- Position resolution $< 30 \mu\text{m}$ (BPM diameter $d=180$ mm)
- average over 1000 turns corresponding to ≈ 1 ms or ≈ 1 kHz bandwidth

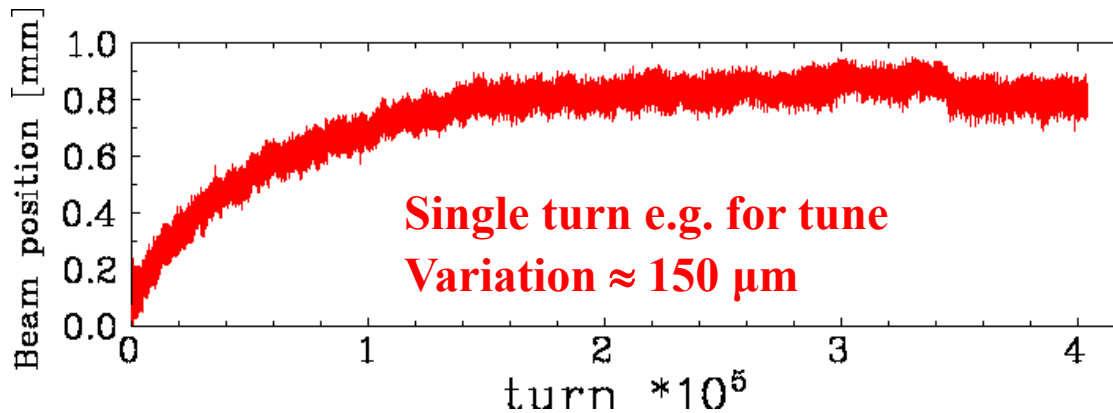

- Turn-by-turn data have much larger variation

However: not only noise contributes but additionally **beam movement** by betatron oscillation
 \Rightarrow broadband processing i.e. turn-by-turn readout for tune determination.

Analog versus Digital Signal Processing

Modern instrumentation uses **digital** techniques with extended functionality.

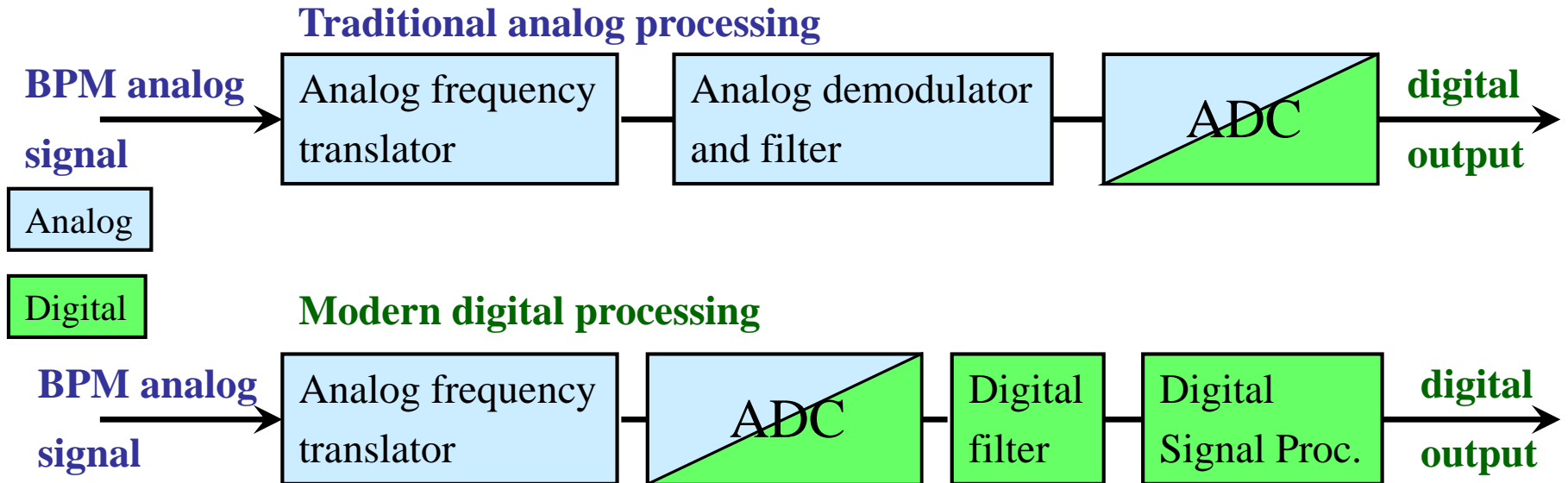

Digital receiver as modern successor of super heterodyne receiver

- Basic functionality is preserved but implementation is very different
- Digital transition just after the amplifier & filter or mixing unit
- Signal conditioning (filter, decimation, averaging) on FPGA

Advantage of DSP: Versatile operation, flexible adoption without hardware modification

Disadvantage of DSP: non, good engineering skill requires for development, expensive

Comparison of BPM Readout Electronics (simplified)



Type	Usage	Precaution	Advantage	Disadvantage
Broadband	p-sychr.	Long bunches	Bunch structure signal Post-processing possible Required for transfer lines with few bunches	Resolution limited by noise
Narrowband	all sychr.	Stable beams >100 rf-periods	High resolution	No turn-by-turn Complex electronics
Digital Signal Processing	all	ADC sample typ. 250 MS/s	Very flexible & versatile High resolution Trendsetting technology for future demands	Basically non! Limited time resolution by ADC → under-sampling Man-power intensive

Outline:

- Signal generation → transfer impedance
- Capacitive *button* BPM for high frequencies
used at most proton LINACs and electron accelerators
- Capacitive *linear-cut* BPM for low frequencies
used at most proton synchrotrons due to linear position reading
- Electronics for position evaluation
analog signal conditioning to achieve small signal processing
- **BPMs for measurement of closed orbit, tune and further lattice functions**
frequent application of BPMs
- **Summary**

Trajectory Measurement with BPMs

Trajectory:

The position delivered by an **individual bunch** within a transfer line or a synchrotron.

Main task: Control of matching (center and angle), first-turn diagnostics

Example: LHC injection 10/09/08 i.e. first day of operation !

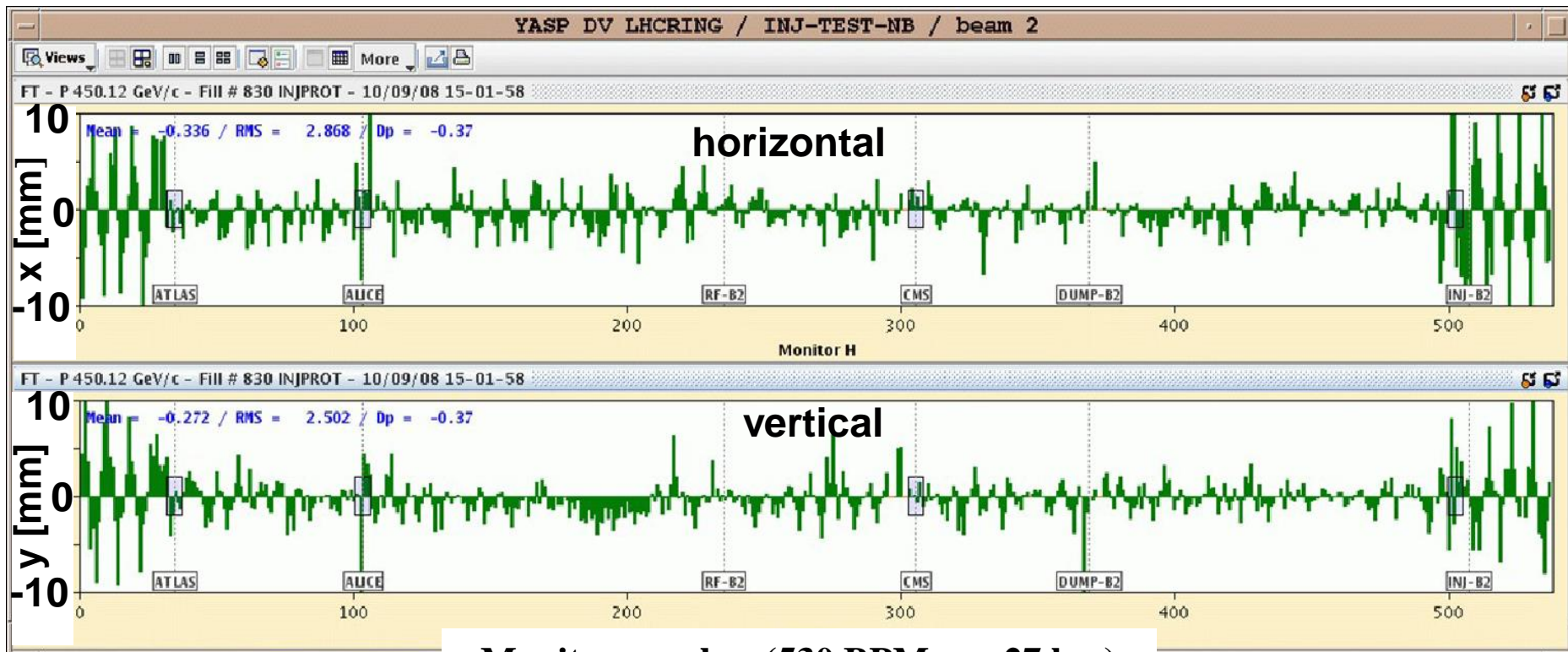

Monitor number (530 BPMs on 27 km)

From R. Jones (CERN)

Tune values: $Q_h = 64.3$, $Q_v = 59.3$

Close Orbit Measurement with BPMs

Single bunch position averaged over 1000 bunches → closed orbit with ms time steps.

It differs from ideal orbit by misalignments of the beam or components.

Example: GSI-synchrotron at two BPM locations, 1000 turn average during acceleration:

Closed orbit:

Beam position averaged over many turns (i.e. betatron oscillations).
The result is the basic tool for alignment & stabilization

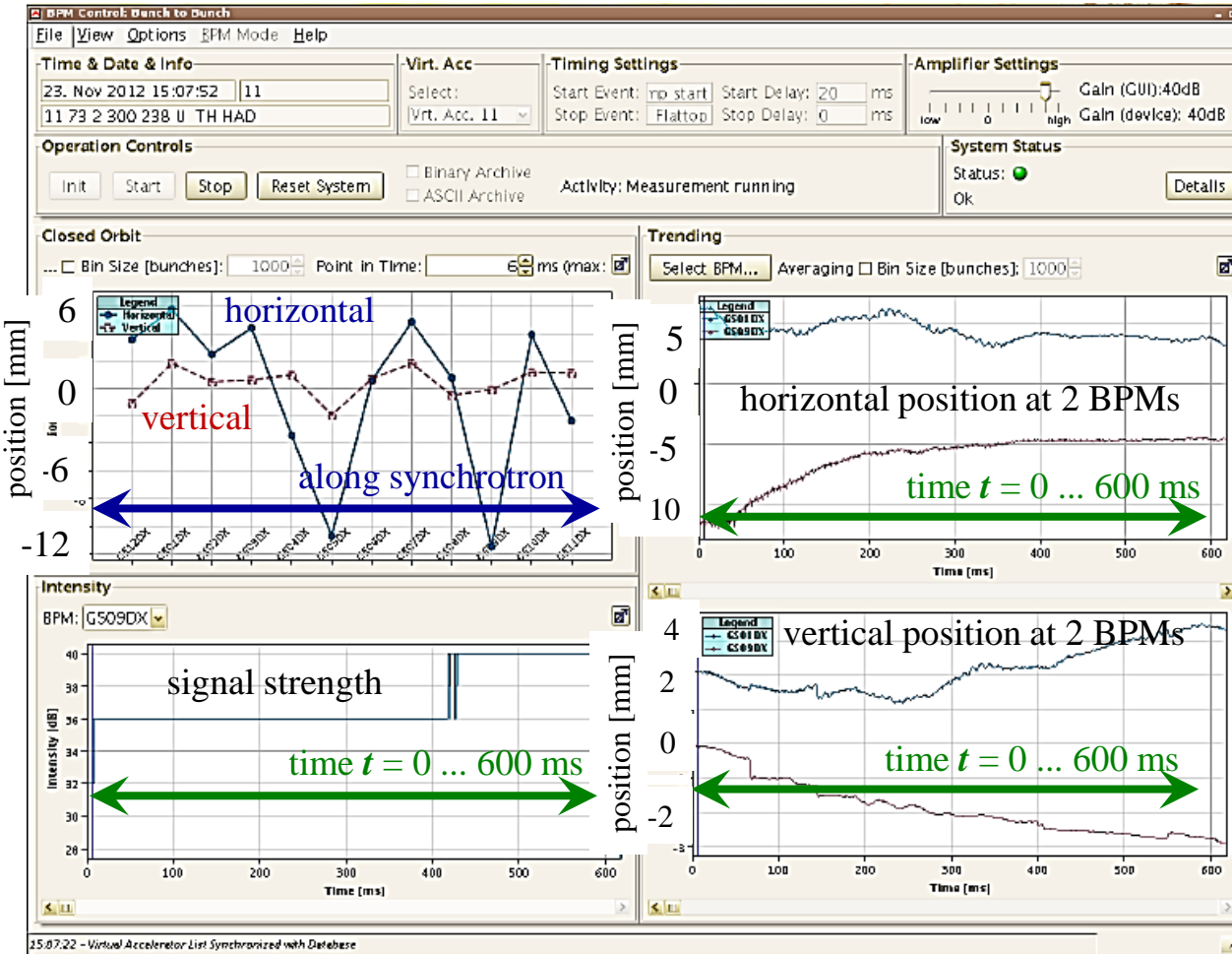

Closed Orbit Feedback: Typical Noise Sources

Beam movement:

Short term (min to 10 ms):

- Traffic
- Machine (crane) movements
- Water & vacuum pumps
- 50 Hz main power net

Medium term (day to min):

- Movement of chambers due to heating by radiation
- Day-night variation
- tide, moon cycle

Lang term (> days):

- Ground settlement
- Seasons, temperature variation

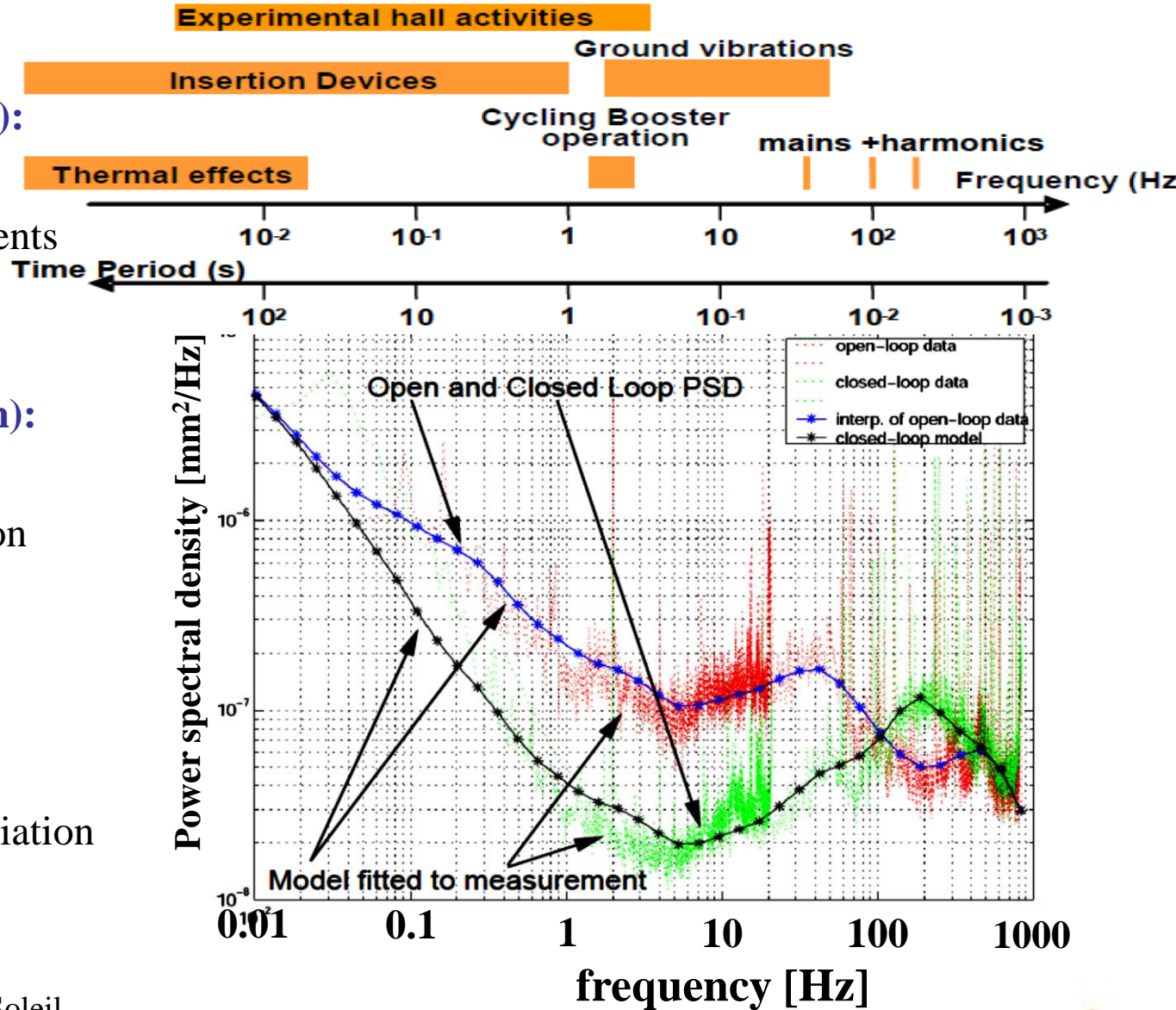

From M. Böge, PSI, N. Hubert, Soleil

Close Orbit Feedback: BPMs and magnetic Corrector Hardware



Orbit feedback: Synchrotron light source → spatial stability of light beam

Example from SLS-Synchrotron at Villigen, Swiss:

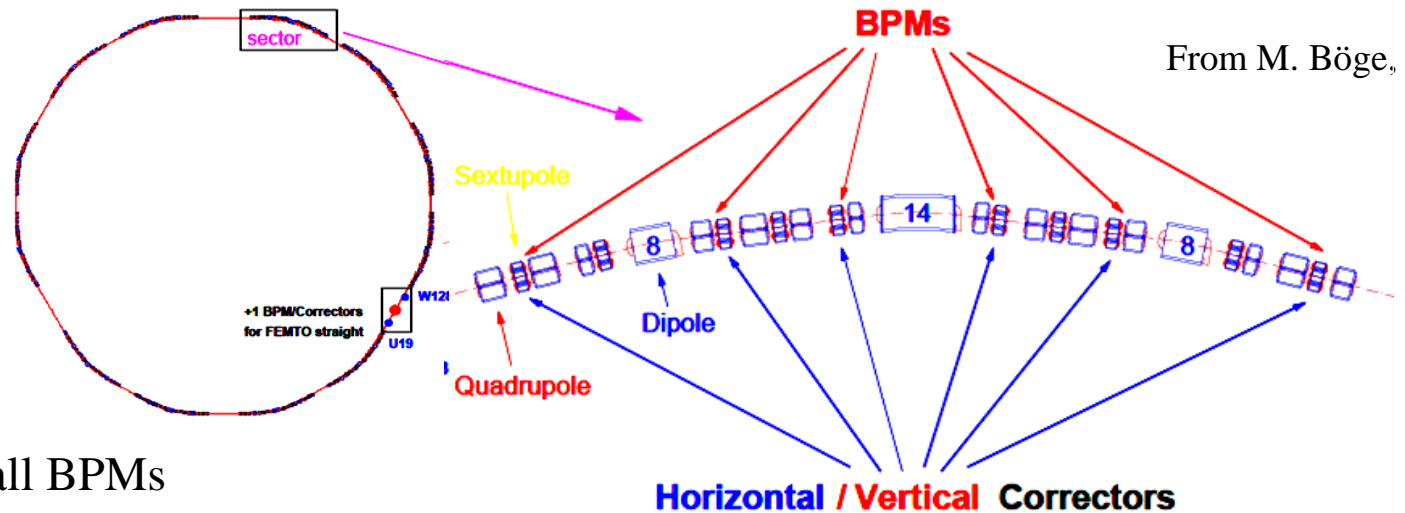

From M. Böge, PSI

Procedure:

1. Position from all BPMs
 2. Calculation of corrector setting via Orbit Response Matrix (→ V. Ziemann)
 3. Digital feedback loop
- ⇒ regulation time down to 10 ms
- ⇒ Role of thumb: ≈ 4 BPMs per betatron wavelength

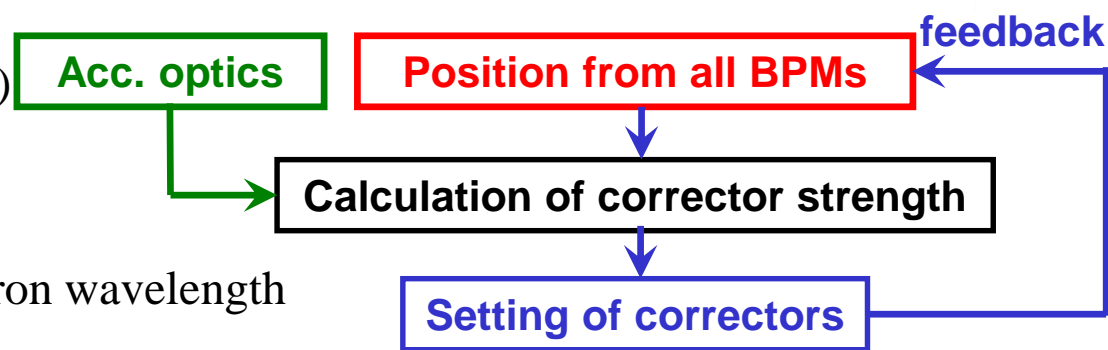

Uncorrected orbit: typ. $\langle \alpha^2 \rangle_{rms} \approx 1$ mm

Corrected orbit: $\langle \alpha^2 \rangle_{rms} \approx 1$ μ m up to 100 Hz bandwidth!

Tune Measurement: General Considerations



Coherent excitations are required for the detection by a BPM

Beam particle's *in-coherent* motion \Rightarrow center-of-mass stays constant

Excitation of **all** particles by rf \Rightarrow *coherent* motion

\Rightarrow center-of-mass variation turn-by-turn i.e. center acts as **one** macro-particle

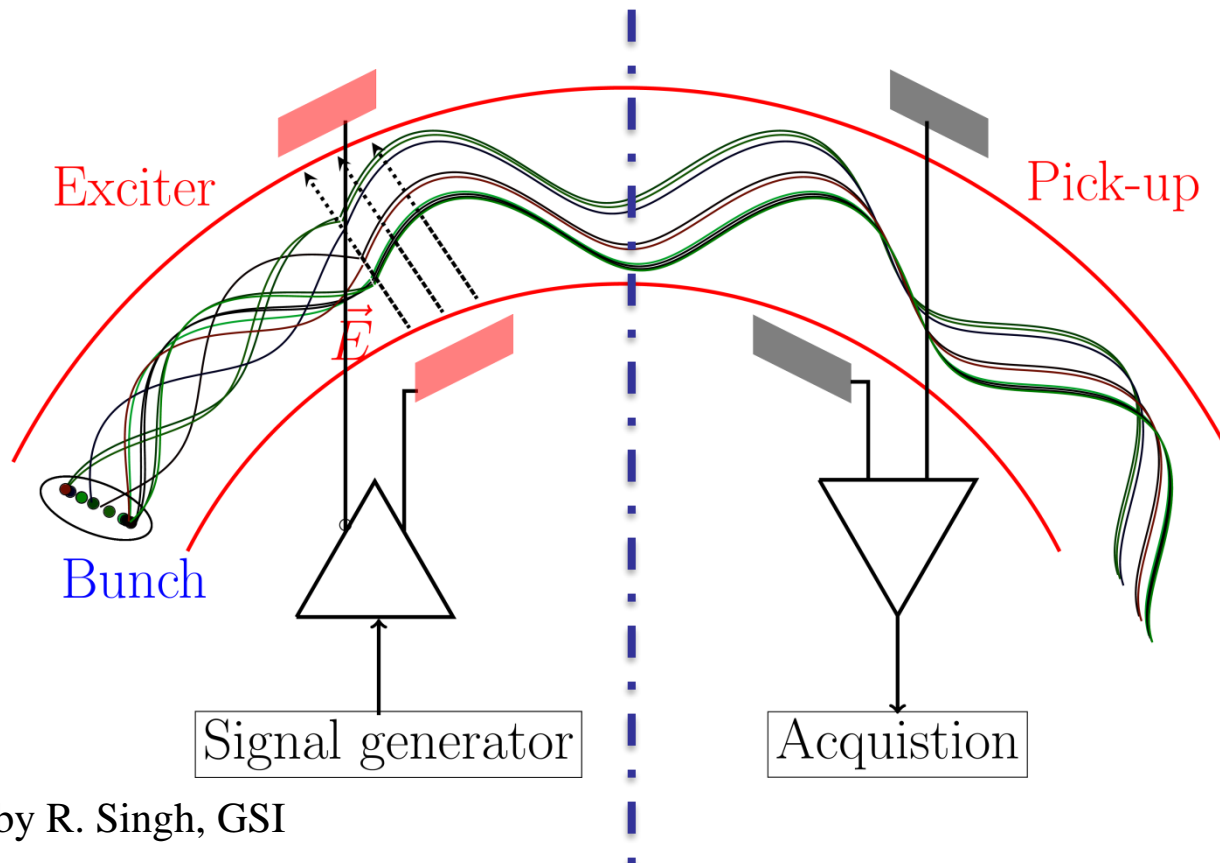

Graphics by R. Singh, GSI

Tune Measurement: The Kick-Method in Time Domain

The beam is excited to coherent betatron oscillation
 → the beam position measured each revolution ('turn-by-turn')
 → Fourier Trans. gives the non-integer tune q .
 Short kick compared to revolution.

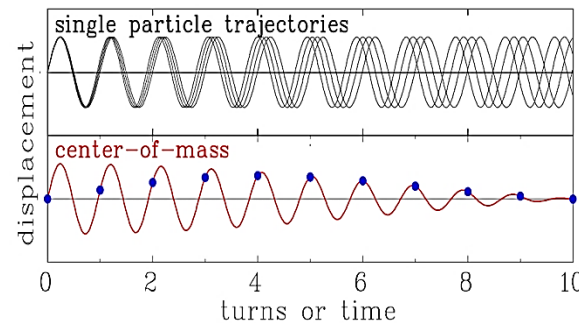
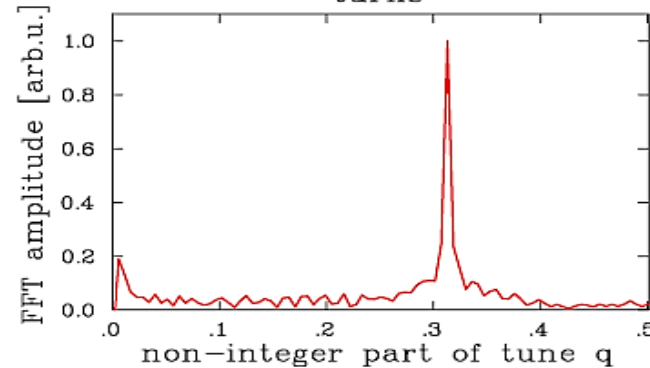
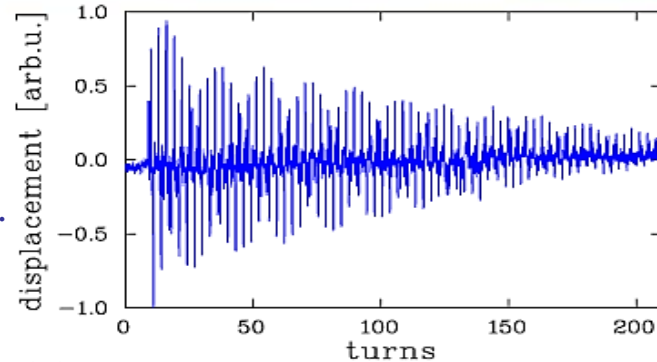
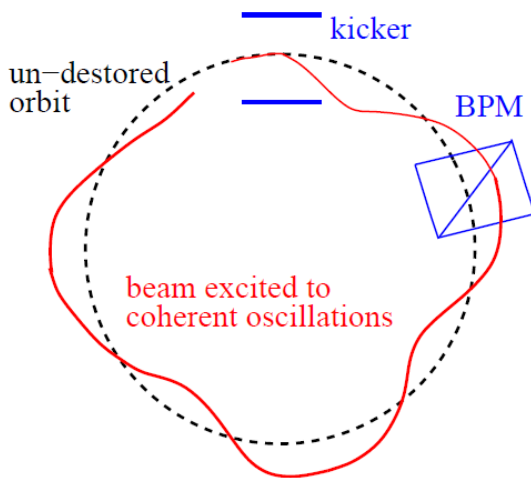

Decay is caused by de-phasing, **not** by decreasing single particle amplitude.

The de-coherence time limits the **resolution**:

N non-zero samples
 ⇒ General limit of discrete FFT: $\Delta q > \frac{1}{2N}$

Here: $N = 200$ turn ⇒ $\Delta q > 0.003$
 (tune spreads can be $\Delta q \approx 0.001!$)

Tune Measurement: Gentle Excitation with Wideband Noise

Instead of a sine wave, noise with adequate bandwidth can be applied

→ beam picks out its resonance frequency: *Example:* Vertical tune within 4096 turn duration ≈ 15 ms at GSI synchrotron 11 → 300 MeV/u in 0.7 s

- broadband excitation with white noise of ≈ 10 kHz bandwidth
- turn-by-turn position measurement
- Fourier transformation of the recorded data
- ⇒ Continues monitoring with low disturbance

vertical tune at fixed time ≈ 15 ms

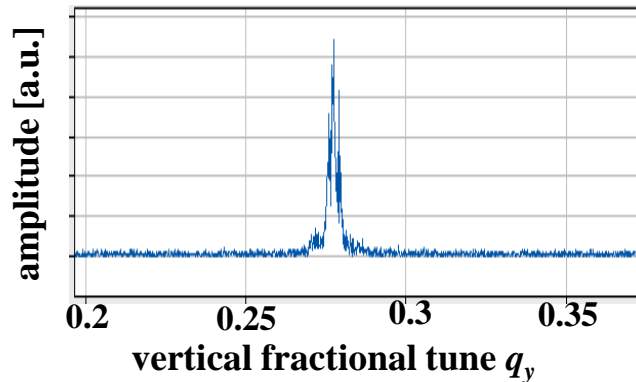

Advantage:

Fast scan with good time resolution

vertical tune versus time

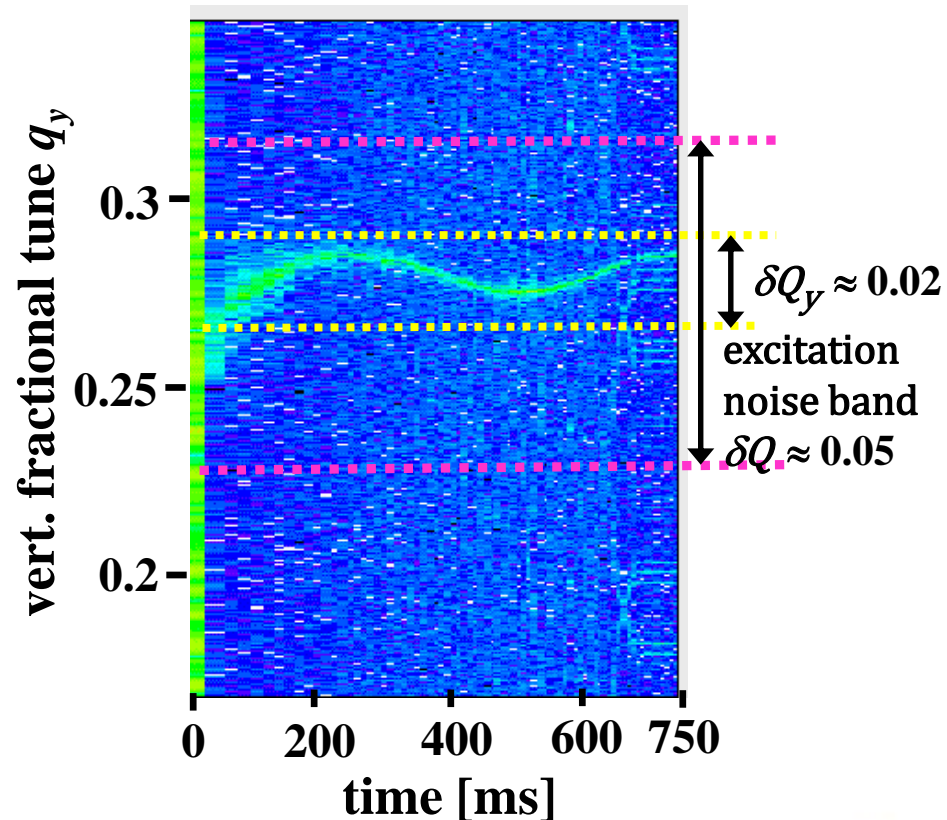

Chromaticity Measurement from Closed Orbit Data

Chromaticity ξ : Change of tune for off-momentum particle $\frac{\Delta Q}{Q} = \xi \cdot \frac{\Delta p}{p}$

Two step measurement procedure:

1. Change of momentum p by detuned rf-frequency $\frac{\Delta p}{p} = \eta^{-1} \cdot \frac{\Delta f_{acc}}{f_{acc}}$
2. Excitation of coherent betatron oscillations and tune measurement

(kick-method, BTF, noise excitation):

Plot of $\Delta Q/Q$ as a function of $\Delta p/p$

\Rightarrow slope is dispersion ξ .

Example: Measurement at LEP:

momentum shift $\Delta p/p$ [%]

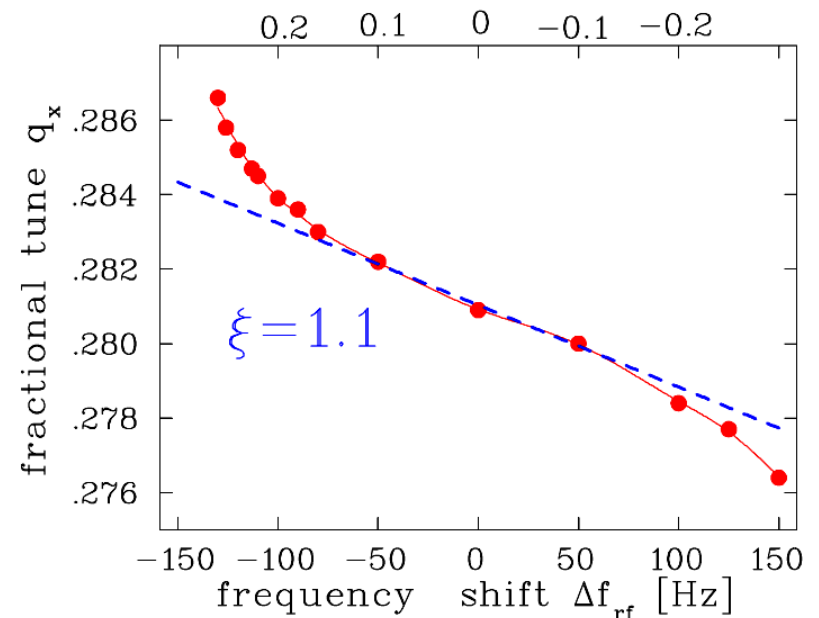

From M Minty, F. Zimmermann,
Measurement and Control of charged Particle Beam,
Springer Verlag 2003

β -Function Measurement from Bunch-by-Bunch BPM Data



Excitation of **coherent** betatron oscillations:

→ Time-dependent position reading results the phase advance between BPMs

The phase advance is:

$$\Delta\mu = \mu_i - \mu_0$$

β -function from

$$\Delta\mu = \int_{s_0}^{s_i} \frac{ds}{\beta(s)}$$

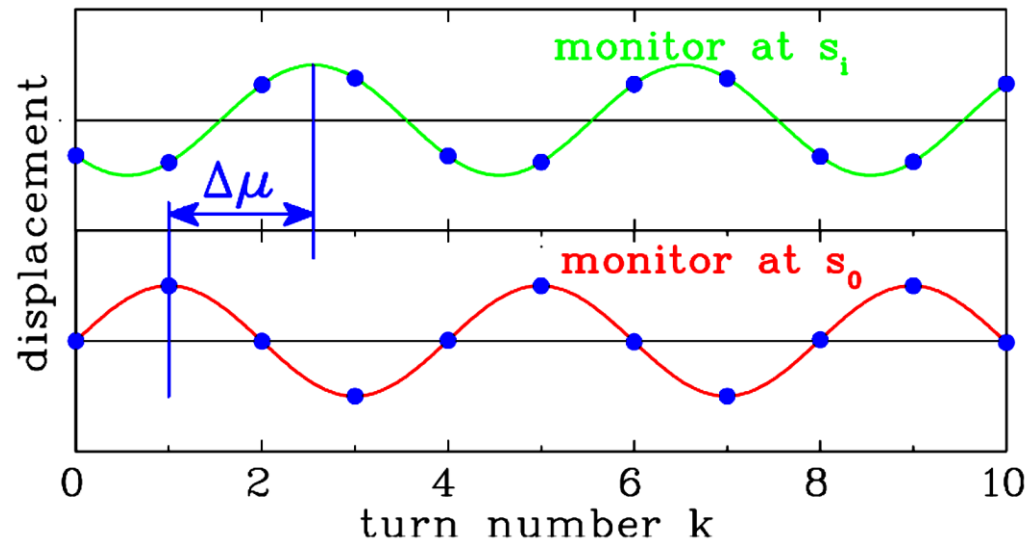

'Beta-beating' from Bunch-by-Bunch BPM Data

Example: 'Beta-beating' at BPM $\Delta\beta = \beta_{meas} - \beta_{model}$ with measured β_{meas} & calculated β_{model} for each BPM at BNL for RHIC (proton-proton or ions circular collider with 3.8 km length)

Result concerning 'beta-beating':

- Model doesn't fit reality completely
e.g. caused by misalignments
- Corrections executed
- Increase of the luminosity

Remark:

Measurement accuracy depends on

- BPM accuracy
- Numerical evaluation method

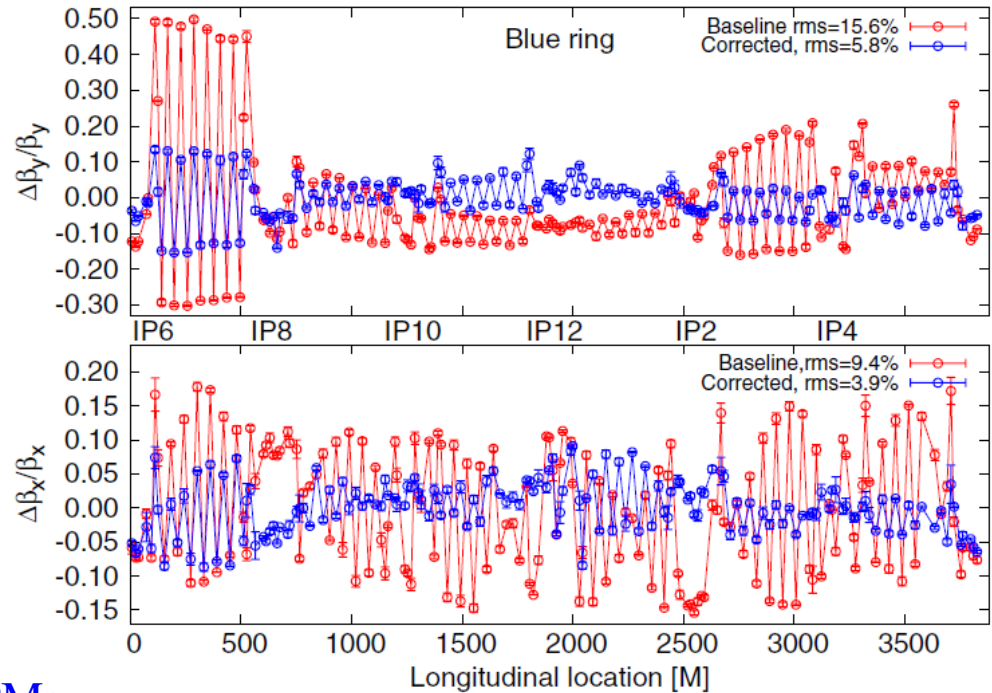

Determination of β -function with 3 BPMs:

$$\beta_{meas}(BPM_1) = \beta_{model}(BPM_1) \cdot \frac{\cot[\mu_{meas}(1 \rightarrow 2)] - \cot[(\mu_{meas}(1 \rightarrow 3))]}{\cot[\mu_{model}(1 \rightarrow 2)] - \cot[\mu_{model}(1 \rightarrow 3)]}$$

See e.g.: R. Tomas et al., Phys. Rev. Acc. Beams **20**, 054801 (2017)
A. Wegscheider et al., Phys. Rev. Acc. Beams **20**, 111002 (2017)

From X. Shen et al.,
Phys. Rev. Acc. Beams **16**, 111001 (2013)

Dispersion Measurement from Closed Orbit Data

Dispersion $D(s_i)$: Change of momentum p by detuned rf-cavity $\frac{\Delta p}{p} = \eta^{-1} \cdot \frac{\Delta f_{acc}}{f_{acc}}$

→ Position reading at one location $x_i = D(s_i) \cdot \frac{\Delta p}{p}$; η : frequency slip factor

→ Result from plot of x_i as a function of $\Delta p/p \Rightarrow$ slope is local dispersion $D(s_i)$

Example: Dispersion measurement $D(s)$ at BPMs at CERN SPS

Theory-experiment correspondence after correction of

- BPM calibration
- quadrupole calibration

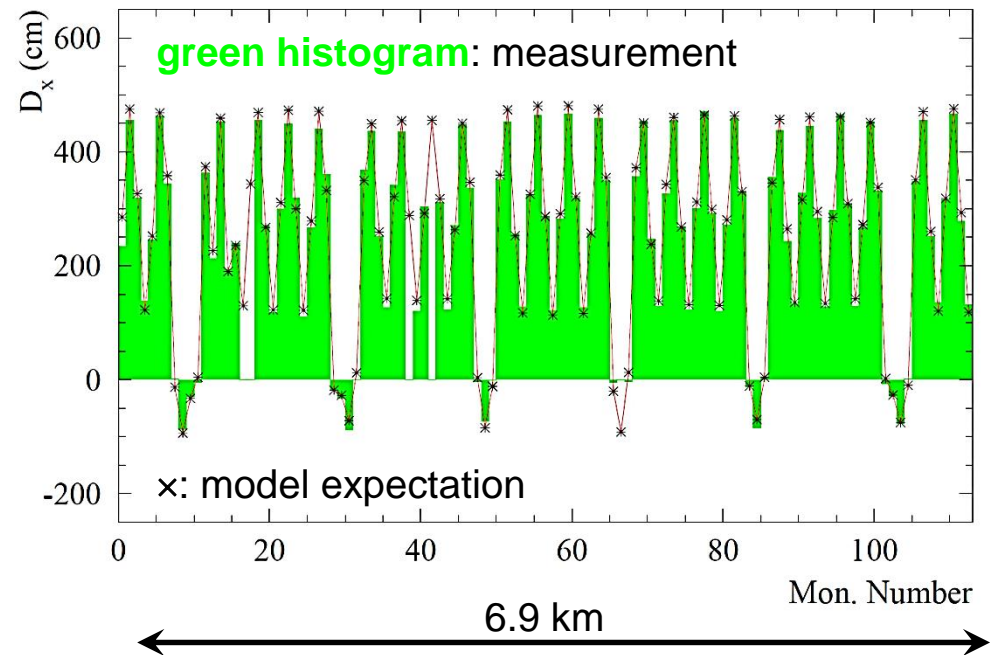

From J. Wenninger: CAS on BD, CERN-2009-005 & J. Wenninger CERN-AB-2004-009

Summary Pick-Ups for bunched Beams



The electric field is monitored for bunched beams using rf-technologies ('frequency domain'). Beside transformers they are the most often used instruments!

Differentiated or proportional signal: rf-bandwidth \leftrightarrow beam parameters

Proton synchrotron: 1 to 100 MHz, mostly 1 M Ω \rightarrow proportional shape

LINAC, e⁻-synchrotron: 0.1 to 3 GHz, 50 Ω \rightarrow differentiated shape

Important quantity: transfer impedance $Z_t(\omega, \beta)$.

Types of capacitive pick-ups:

Linear-cut (p-synch.), button (p-LINAC, e⁻-LINAC and synch.)

Position reading: difference signal of four pick-up plates (BPM):

- Non-intercepting reading of center-of-mass \rightarrow online measurement and control
 - Synchrotron: slow reading* \rightarrow closed orbit, *fast bunch-by-bunch* \rightarrow trajectory
- *Synchrotron:* Excitation of *coherent* betatron oscillations \Rightarrow tune $q, \xi, \beta(s), D(s)$...

Remark: BPMs have high pass characteristic \Rightarrow no signal for dc-beams

Thank you for your attention!