

TEACHER IN RESIDENCE

TEACHER IN RESIDENCE

Oder: Susy am CERN – und es gibt Sie doch! ;-)

KAPITEL 1: WIE ALLES BEGANN...

German Teachers Programme

 6 Sep 2009, 17:00 → 11 Sep 2009, 12:00 Europe/Zurich

 6-2-024 - BE Auditorium Meyrin (CERN)

 Mick Storr (CERN) , Sascha Marc Schmeling (CERN)

Description Kontakte:

Sascha Schmeling
Konrad Jende
Rolf Landua

MONDAY, 7 SEPTEMBER

09:00 → 10:00 Einführung

09:00 **Begrüßung und Einführung in das Programm**

Speaker: Dr Sascha Marc Schmeling (CERN)

09:05 **Begrüßung durch den Generaldirektor des CERN**

Speaker: Rolf Heuer (CERN)

KAPITEL 1: WIE ALLES BEGANN...

The screenshot shows a web browser window with the following content:

- Browser Tabs:** "Neuer Tab" and "German Teachers Programme (X +)".
- Address Bar:** "https://indico.cern.ch/event/161525/"
- Page Title:** "German Teachers Programme"
- Event Details:** "7-12 October 2012", "CERN", "Europe/Zurich timezone".
- Search Bar:** "Search..."
- Navigation Menu:**
 - Overview
 - Timetable
 - Registration
 - Support (highlighted)
- Contact:** "gtp-admin@cern.ch"
- Main Text:**

Das dritte deutsche Lehrerprogramm 2012 findet vom 7. Oktober bis zum 12. Oktober statt.

Dieser Workshop wird organisiert in Kooperation mit dem „Netzwerk Teilchenwelt“ – einem Netzwerk von Wissenschaftlern, Jugendlichen und Lehrkräften zur Vermittlung von Teilchenphysik an Schulen, Schülerlaboren und anderen Bildungseinrichtungen. Für aktive Mitglieder besteht die Möglichkeit der Vollfinanzierung des Workshops als Teil des Qualifizierungsprogramms von Netzwerk Teilchenwelt. In diesem Fall erfolgt die Registrierung auf [dieser Seite](#).

Falls Sie Interesse an einer Mitarbeit im deutschlandweit aktiven Netzwerk oder Fragen hierzu haben informieren Sie sich bitte auf www.teilchenwelt.de oder wenden Sie sich direkt an die Projektkoordination des Netzwerks Teilchenwelt: mail@teilchenwelt.de, Tel. +49-351-463-33769.

Für allgemeine Informationen zum Programm und den Archiven der letzten Lehrerfortbildungsprogramme inklusive den Vorträgen, folgen Sie bitte diesem [Link](#). Eine weitere deutschsprachige Lehrerfortbildung 2012 findet im Oktober statt.
- Taskbar:** Shows various application icons and system tray information: "23:38 19.07.2018".

KAPITEL 2: VON BAYERN ÜBER DRESDEN ANS CERN



Fakultät Mathematik und Naturwissenschaften

In der **Fachrichtung Physik** der **TU Dresden, Institut für Kern- und Teilchenphysik** und am **CERN in Genf** ist ab **01.03.2017** eine Stelle als

wiss. Mitarbeiter/in als Project Associate

im FSP-Pilotprojekt „Spitzenforschung, Erkenntnisvermittlung und Nachwuchsgewinnung aus einer Hand“

(bei Vorliegen der persönlichen Voraussetzungen E 13 TV-L)

mit 90% der regelmäßigen wöchentlichen Arbeitszeit, davon 45% fremdfinanziert, befristet bis 31.03.2018 (Beschäftigungsdauer gem. WissZeitVG) mit Dienstort am CERN, Genf (Schweiz) zu besetzen. Um eine längere Einarbeitungszeit zu ermöglichen, kann die Stelle ggf. bereits ab 01.02.2017 besetzt werden.

Das Pilotprojekt der vier Forschungsschwerpunkte (FSPs) am LHC (ALICE, ATLAS, CMS und LHCb) soll die FSP-übergreifende Zusammenarbeit in den Gebieten Öffentlichkeitsarbeit, LHC-Kommunikation und Erkenntnisvermittlung an Jugendliche und Studierende in Deutschland deutlich intensivieren. Junge Menschen sollen frühzeitig mit den Forschungsthemen der experimentellen Teilchenphysik in Kontakt kommen. So sollen Interesse für die Wissenschaft gefördert und neuer Nachwuchs für Grundlagenforschung an Großgeräten gewonnen werden.

Das Pilotprojekt baut auf den bereits existierenden Strukturen von „Netzwerk Teilchenwelt“ auf. Das bundesweite "Netzwerk Teilchenwelt" bringt junge Menschen und Lehrkräfte in Kontakt mit hochaktueller Forschung am Europäischen Laboratorium für Teilchenphysik (CERN). Jugendliche und Lehrkräfte erhalten die Möglichkeit, auf den Gebieten der Teilchenphysik und Astroteilchenphysik eigene nachhaltige und authentische Erfahrungen mit realen experimentellen Daten aus der aktuellen Forschung zu machen. Das Programm von Netzwerk Teilchenwelt umfasst eine Vertiefungsstufe, bei der Jugendliche Vor-Ort Erfahrungen am CERN sammeln sollen. Eine ausführliche Beschreibung des Projekts findet sich unter www.teilchenwelt.de.

KAPITEL 2: VON BAYERN ÜBER DRESDEN ANS CERN



KAPITEL 2: VON BAYERN ÜBER DRESDEN ANS CERN

Werdenfels-Gymnasium • Postfach 19 64 • 82467 Garmisch-Partenkirchen

Über die Schulleitung

An das Bayerische Staatsministerium
für Bildung und Kultus, Wissenschaft und Kunst

Salvatorstr. 2
80327 München

Garmisch-Partenkirchen, 16.01.17

Sehr geehrte Damen und Herren,

die TU Dresden hat, gemeinsam mit dem CERN in Genf, zum 01.03.2017 eine Stelle für einen wissenschaftlichen Mitarbeiter im FSP-Pilotprojekt „Spitzenforschung, Erkenntnisvermittlung und Nachwuchsgewinnung aus einer Hand“ ausgeschrieben (siehe Anhang). Die Stelle ist befristet bis zum 31.03.2018. Nachdem ich, mit Einverständnis meiner Schulleitung, mich erfolgreich für diese Stelle beworben habe, liegt mir nun das Stellenangebot vor.

Gerne würde ich die Chance, dieses Projekt mitzugestalten aber auch meine eigenen Kompetenzen erweitern zu können, wahrnehmen. Daher bitte ich darum, mich für diesen Zeitraum für diese Stelle abzuordnen oder mich zu beurlauben.

Vielen Dank im Voraus für Ihre Mühen,

mit freundlichen Grüßen,

KAPITEL 2: VON BAYERN ÜBER DRESDEN ANS CERN



NETZWERK
TEILCHENWELT QUARKS, ELEKTRONEN & CO.



DAS PROJEKT | AKTUELLES | MITMACHEN | ANGEBOTE | STANDORTE | MATERIAL | FORUM |

Sie sind hier: Angebote > CERN-Workshops



CERN-Workshops

Links zum Artikel

- ▶ Termine, Infos und Anmeldung zu den Workshops
- ▶ CERN German Teachers Programme

Artikel zum Thema

- ▶ Informationen für (angehende) Lehrkräfte
- ▶ Informationen für Jugendliche

Nachrichten zum Thema

- ▶ 03.06.2018 Jugendliche forschen am CERN - Jetzt bewerben für Projektwochen

KAPITEL 3: PJAS FÜR NTW AM CERN



KAPITEL 3: PJAS FÜR NTW AM CERN

- Jugendworkshops:



KAPITEL 3: PJAS FÜR NTW AM CERN

- Projektwochen

Netzwerk Teilchenwelt: German high-school students at CERN

by Susanne Duhrkoop

UPDATES

[Introducing gender-inclusive teaching](#)

26 Jun 2018

[more >](#)

UPCOMING SCHOOLS

[HASCO Summer School 2018](#)

HASCO Summer School, from 22 Jul 2018 to 27 Jul 2018 – University of Göttingen

[Winter School: Topics on Gravitículas](#)

Theoretical Schools, from 23 Jul 2018 to 28 Jul 2018 – Other Institutes

[46th SLAC Summer Institute](#)

SLAC Summer Institute, from 30 Jul 2018 to 11 Aug 2018 – SLAC

Posted by [Iva Raynova](#) on 27 Oct 2017. Last updated 27 Oct 2017, 21.18.

This content is archived on the [CERN Document Server](#)



Matteo Kumar, Jan Eckerlein, Tim Hebenstreit, Elisabeth Walter and Sophie Li during their two-week project at CERN. (Image: Susanne Duhrkoop/CERN)

KAPITEL 3: PJAS FÜR NTW AM CERN

- Teachers Summer School

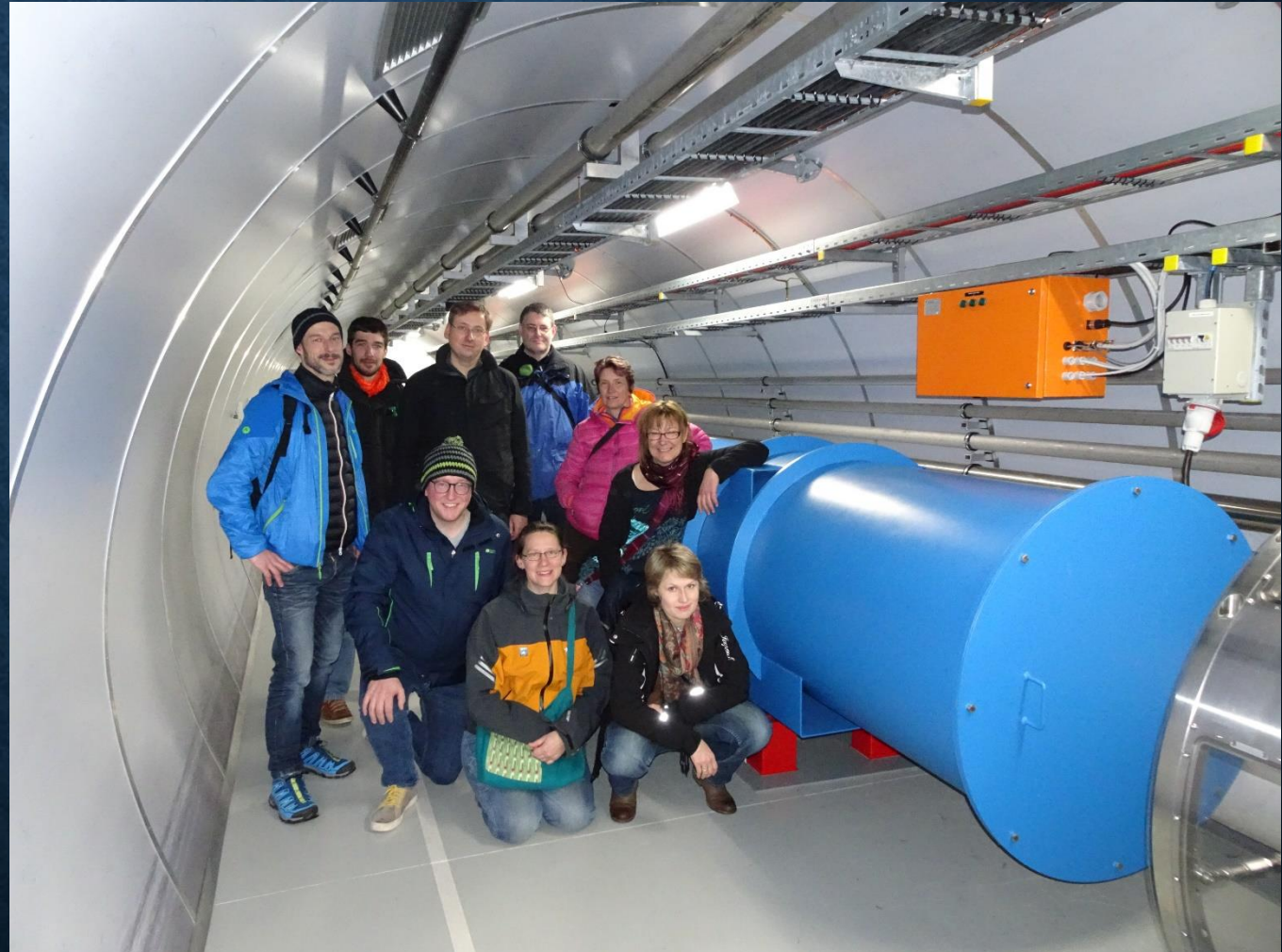

S'Cool LAB

There is always a way to do it better... find it!

If you can't explain it simply, you don't understand it well enough.



WHAT IS S'COOL LAB?

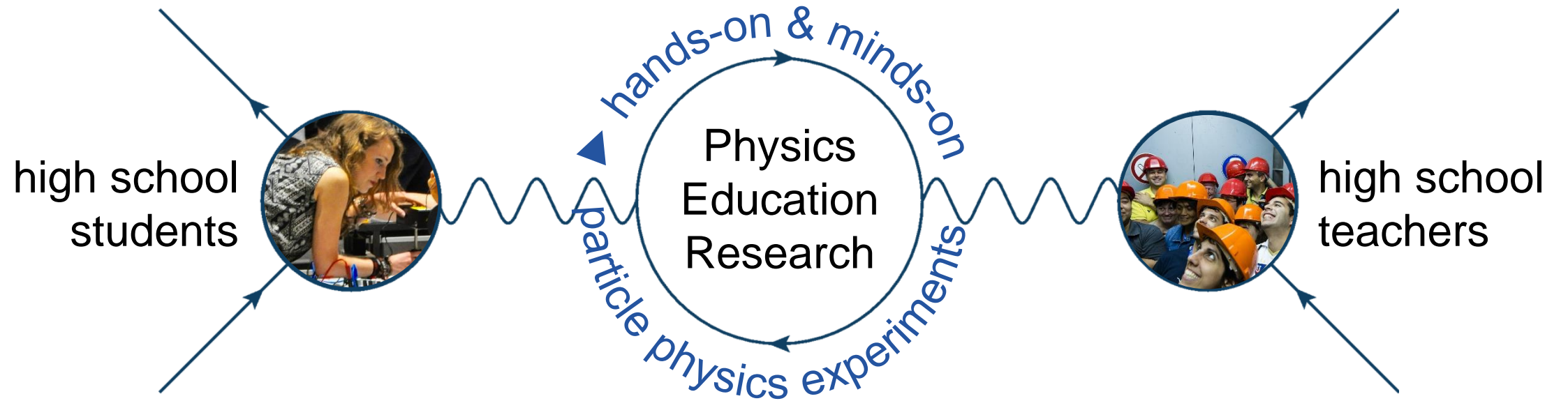

KAPITEL 4: TEACHER IN RESIDENCE



S'Cool LAB

There is always a way to do it
better... find it!

If you can't explain it simply,
you don't understand it well enough.



EXPERIMENTS: HIGH-TECH VS. LOW-COST

In S'Cool LAB: high-tech

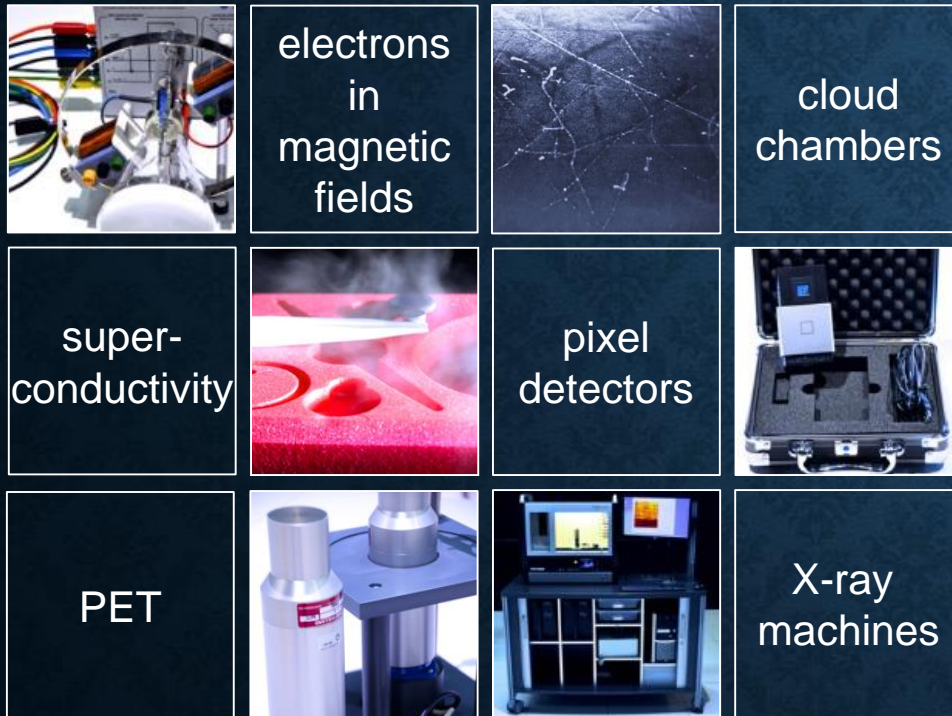

For the classroom: low-cost

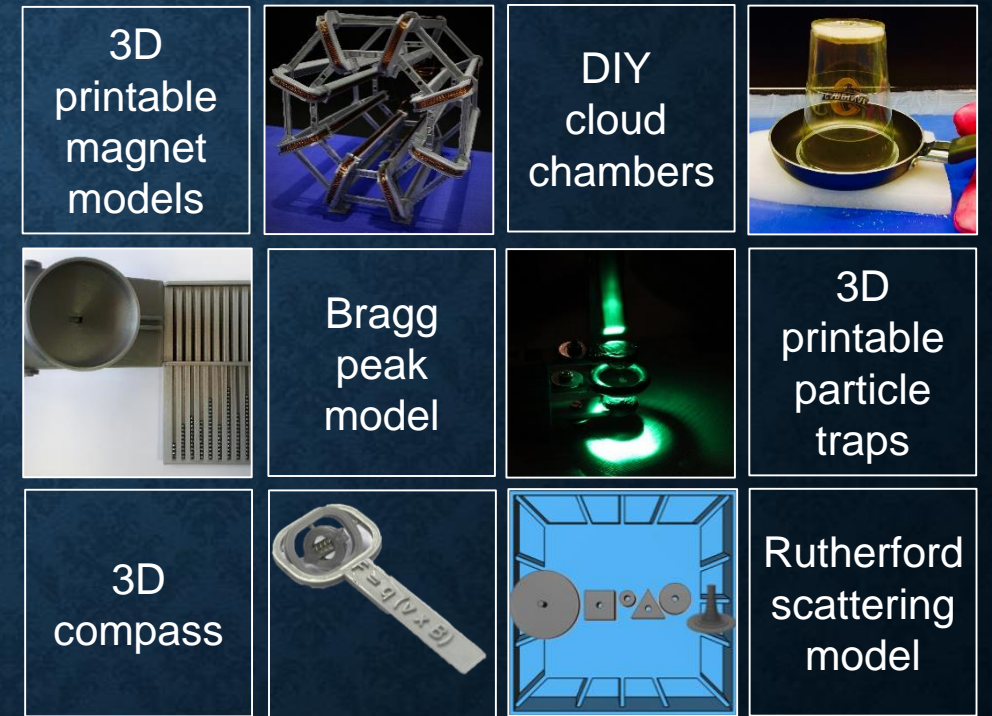

... and many more to come



Teacher in Residence!

DATABASE

	A	B	C	D	E	F	G	H	I	J	K	L	M
	Resource Name	Topic	Type	Language	Age	Supervision Necessary	Required Materials	Website	Author	Description	3D printable	Worth Investigating? (number out of 10)	
1	Cloud Chamber Do-it-yourself manual	Cloud Chamber	Hands on Activity	English	16+	Yes	Dry ice, isopropanol	http://ippog.org/sites/ippog.web.cern.ch/files/SC	Julia Woithe	Instructions for building a cloud chamber from scratch.			
2	International Masterclass	Data Handling	Event - computer based	English	15-19	Yes	Computers, video conferencing, scientists, tutors	http://physicsmasterclasses.org/		Students from a particular area gather and investigate data from the LHC			
3	Be a physicist/dans the skin	Scientific Method	Hands on Activity	English	9-12 years old	yes	Boxes and objects to investigate and test	http://ippog.org/sites/ippog.web.cern.ch/files/livretanglaisfinal.pdf	Saindrine Saison-Marsollier	Students perform an investigation to determine the unknown objects hidden			
4	CMS HEP Tutorial	Data Handling	Computer Activity	English	Under graduates	No	Computer	http://ippog.org/resources/2012/cms-hep-tutorial	Christian Sander and Alexander Schmidt	Students learn programming to handle data from CMS			
5	Mass Calc: Z	Data		English	15-18			Link broken	K cecire	A resource which helps			
6	The Particle Adventure		Computer Activity	English +12 other languages	15-18	No	Computer	http://particleadventure.org/	LBNL	An excellent introduction to particle physics. Note the website itself only contains			
7	Quark-tzee	Standard Model	Game	English	15+	No	Dice, stickers	http://ippog.org/sites/ippog.web.cern.ch/files/j	Helio Takai	A dice game similar to Yahtzee. Students create			
8	The Quark Card Game	Standard Model	Game	English	15+	No	Quark Cards	http://ippog.org/resources/2011/quark-card-	Helio Takai	A modified version of poker. Players are given a hand of 5			
9	Quark Card Dealer	Standard Model	Game	English	12+	No	Cards (Available at website)	https://www.jicfus.jp/en/promotion/pr/quark-					
10	QCD the game	Standard Model	Game	English	15+	No	Cards (can be viewed)	https://tktournament.co		A variety of card games that			
11	The world of particles and their interactions	Standard Model	Game and Activity	English	6-12 years old	Yes	Generic Quark cards	http://creations-project.eu/resources/toolkits/demonstrators-templates/particle-	Dr Maria Pavlidou and Professor Cristina Lazeroni (University of	A game and an activity for primary school children. The game is similar to go fish, but with the standard model. The			
12	Quarkle	Standard Model	Game	English	12+	No	Quarkle Cards (can be bought for \$15 at the	https://www.thegamecraft.com/games/quarkle	Andrew (andrew.huntress	A Quark based game that allows students to become			

PAUL TRAP

What we worked on:

- Refined Trap Design
- Student Worksheets
- Teacher Guidelines and Solutions
- Construction Manual
- Paper



TRAP DESIGN

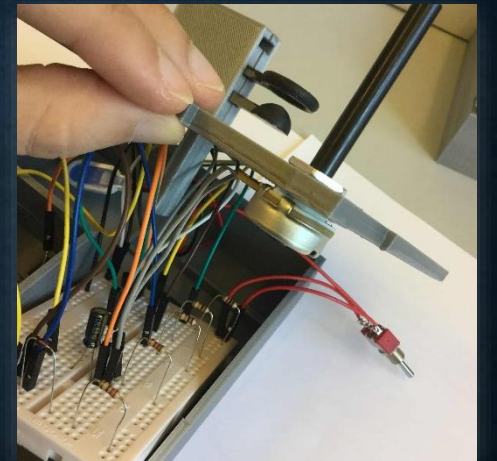
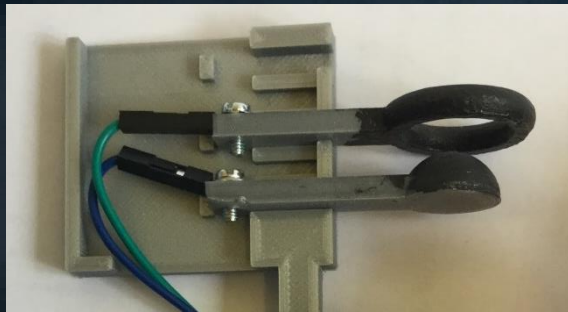
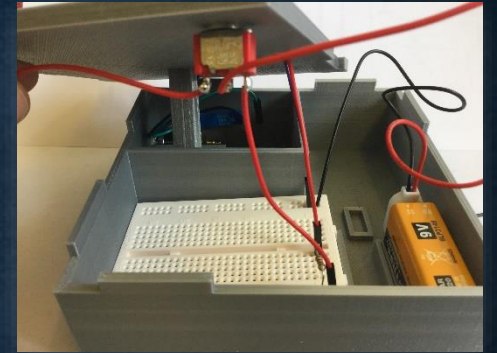
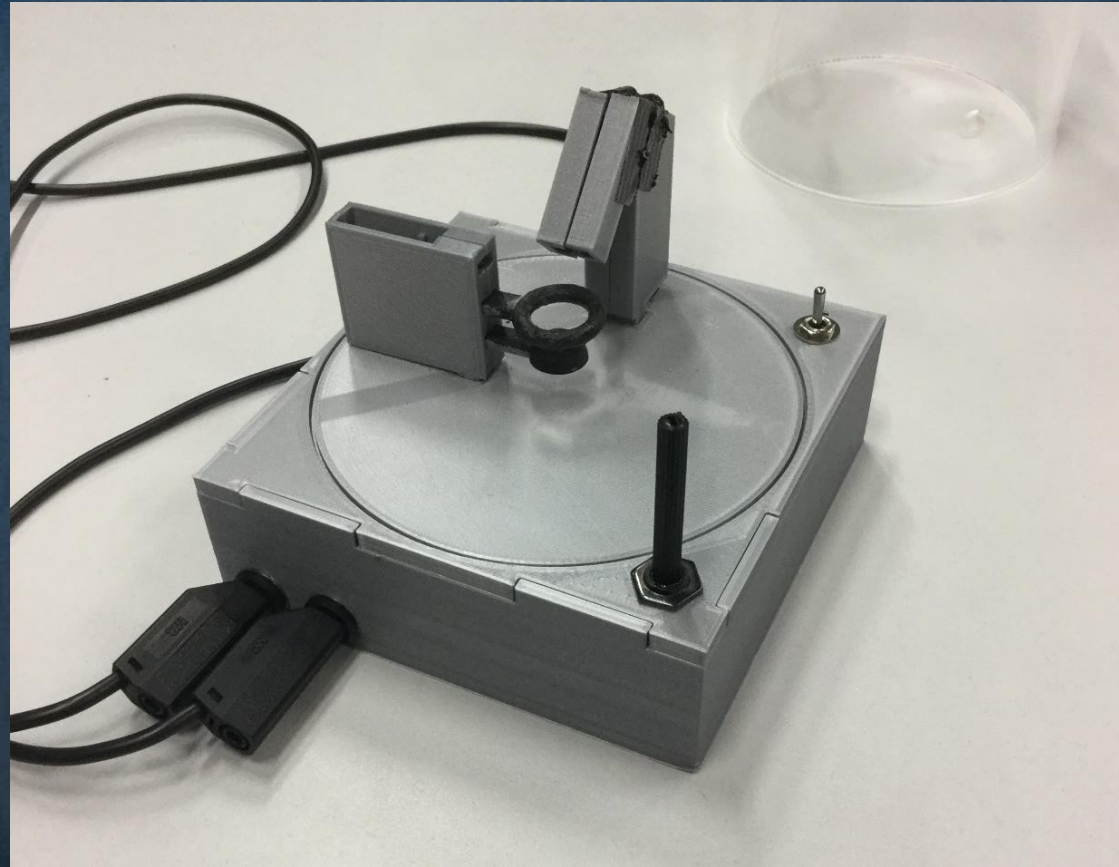
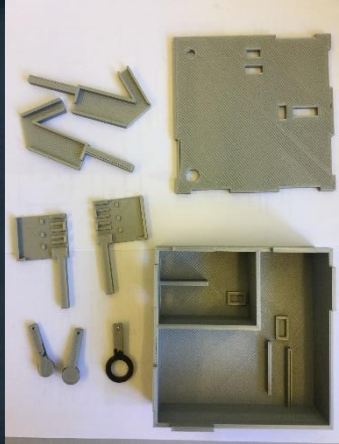

STUDENT WORKSHEETS

S'Cool LAB

For the following experiment, we'll concentrate on the area around the electrodes. This is why we'll use a sketch of the electrodes only, instead of a sketch with the cabling.

Before:

Now:

Draw the electric field lines into the sketches of the electrodes of the usual trap and the one you are going to use. Compare the pictures and conclude on what that means for the construction of the trap. We are going to use the colours to show the momentary charge of the electrodes. (**Remember**, as we use AC voltage the charge will continuously change.)

Trap with upper and lower electrode

Trap with lower electrode only

9

S'Cool LAB

Experiment 1: Trapping the spores
You will now start trapping and see how the spores behave in the trap.

Prediction:
Imagine you place some spores in the centre of the ring electrode. How do you expect them to behave?
Think about how they will be arranged (shape) and where they will be (position).

Decide for one of the shapes **a, b, c, or d** (which are shown bigger than in reality below), and mark the expected **position** of this shape in the sketch of the cross section below.

a)
All at one point

b)
rectangular configuration

c)
diamond-shaped configuration

d)
circular configuration

Example:

Student 1

Student 2

Student 3

Student 4

10

TEACHER GUIDELINES AND SOLUTIONS



For the following experiment, we'll concentrate on the area around the electrodes. This is why we'll use a sketch of the electrodes only, instead of a sketch with the cabling.

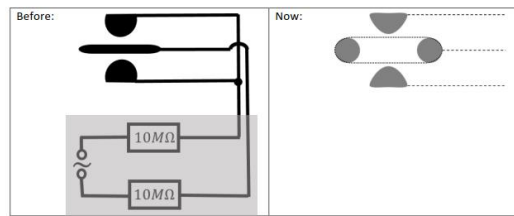

Draw the electric field lines into the sketches of the electrodes of the usual trap and the one you are going to use. Compare the pictures and conclude on what that means for the construction of the trap. We are going to use the colours to show the momentary charge of the electrodes. (Remember, as we use AC voltage the charge will continuously change.)

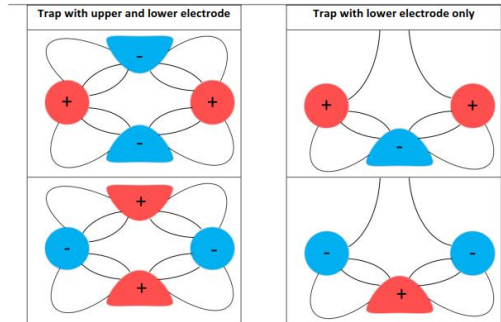

In the inner part, between the electrodes, the shape of electric field does not change significantly when the upper electrode is removed. That's why removing the upper electrode has almost any effect on the experiment.



Appendix:

Further information, you might want to discuss with your students, before performing the workshop

What we will do today:

- You are going to be an antimatter researcher today. Your task is to learn how to trap particles with a quadrupole ion trap.
- Your "particles" today will not be elementary particles like electrons, but very big particle systems, so called lycopodium spores (show container, show picture). Lycopodium spores look like a fine powder; it consists of very small spores (or seeds). Because of friction, these spores are electrically charged.

What is antimatter?

- Ask students first what they think.
- Every particle has a corresponding antiparticle – a very important symmetry in the Standard Model of particle physics. Most of their properties are identical, for example, they have the same mass. However, their electric charge is opposite.
- One example is the positron, which is the antiparticle of the electron. The positron has a positive electric charge.
- If a particle meets its antiparticle they annihilate, they are converted, for example, into two photons. The process can be reversed: if there is enough energy, a particle-antiparticle pair can be produced.
- Question: How would you make an anti-hydrogen atom? (take antiproton, add positron)

Why is antimatter research interesting?

- We know that during the Big Bang equal amounts of matter and antimatter particles have been produced (charge conservation law). Today, we only see matter around us, the antimatter has disappeared.
- We need to study antimatter, to find out if there are maybe small differences between particle and antiparticles that could explain, why we live in a "matter world". Or maybe there is an antimatter world somewhere far away in the universe?

What kind of antimatter experiments are we doing at CERN?

- One of the many experiments is called GBAR.
- It will try to answer a very simple – but exiting question: Imagine you drop a matter apple on our matter Earth. Everyone agrees, that it will fall down. Now, imagine you drop an antimatter apple on an antimatter Earth. What will happen? Everyone agrees, that the same physics rules would apply, so the apple would fall down. (In fact, if we had a switch that could turn all the matter into antimatter, we wouldn't notice any difference).
- Now the exiting question: If you drop an antimatter apple on our matter Earth, will it fall UP or DOWN? Who thinks it would fall upwards? Who thinks downwards? Who thinks it wouldn't move at all?
- Most physicist believe, it would fall down, but we have never done this experiment!
- Because an antimatter apple is a very complex system, at CERN we use the most simple particle system: an antihydrogen atom
- GBAR will therefore first trap antihydrogen and then do a freefall experiment with it.
 - Question: Why do you we need to trap the antihydrogen atoms first?

CONSTRUCTION MANUAL

3. Required Materials

The Table 3.1 below presents all the required materials to build the quadrupole ion trap. Note that the components highlighted in blue are sufficient if you do not intend to build the blinking circuit.

Description	Picture	Price	Online Shop	Stock Number
2 x Resistor (10 M Ω)		8 €		2960572
Multi Contact 4mm Banana plug sockets		6 € for 2 pieces		404-200
1 x Toggle Switch On-Off-On*		25 € for 5 pieces		448-0753
Male to Male Leads (9 required) Male to Female Leads (6 required)		5 € for packs of 10 (20 € total)		791-6463 791-6454
Electric Paint (Bare Conductive)		20 € for 50 ml	RS Components http://www.rs-components.com	835-2693
Breadboard		18 €	*Note any on-off switch will work for the non-strobing circuit however an on-off-on switch is required for flasher circuit.	102-9147
Capacitors 1 x 1 μ F 1 x 10 μ F		Come in packs of 4 for 2 € (4E)		374-910 0571256
Diode		Packs of 10 for 5 €		251-3025
2 x NPN Transistor		Packs of 10 for 3 €		739-0442
Resistors 1 x 100 Ω 2 x 10 Ω 1 x 8.2 k Ω 1 x 10 k Ω		Come in packs of 10 for 3 € (total 12 €)		707-8063 707-8827 707-8902 707-8300
10 k Ω Potentiometer		3 €		468-8705
Battery Strap (Clip)		5 for 4 €		489-021
9V Battery		8 €		841-7002 (or 386-9997)
2 x High power LED		0.12 € per piece	Reichelt Elektronik https://www.reichelt.de	LED 3-6000L GN

Table 3.1) List of required materials

Three M2.5x7 (ISO metric screw thread), and three M2.5 Washer are also required.

To build the trap you will also need a paintbrush, scissors, duct tape, screwdrivers and soldering equipment.

Construct the LED circuit following the circuit diagram and/or breadboard schematic.

Attach male to female leads to the LED's before placing on the breadboard.

The diagrams were created using the Fritzing software.

For help identifying resistors please see Section 10: Appendix A – Resistor Bands.

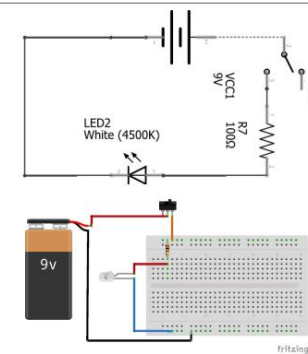

Place the circuit inside the base.

To complete the circuit insert the LED holder and attach the LEDs. Seen final instruction in section 4.2 Strobing Circuit

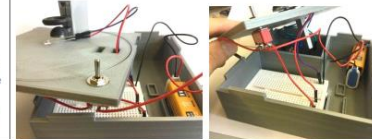

4.2. Strobing Circuit

A good extension of the quadrupole ion trap is to observe the charged particles under a strobing light. This section contains instructions for building an 'astable multivibrator', a circuit that causes an LED to turn on and off multiple times per second. This astable multivibrator contains a switch to switch between strobing and continuous LED's and a potentiometer to change the frequency of strobing. The frequency should range between 30Hz and 70Hz.

Description	Picture
Attach leads to the potentiometer. To do this cut a male-to-male (grey in diagrams below) lead in half and strip the ends. Then solder one lead to the middle pin of the potentiometer and solder the second lead to either of the side pins.	

PAPER

Template of Hardware Metaper

For submission to the *Journal of Open Hardware*

(1) Overview

Title

3D-printable model of a particle trap: development and use in the physics classroom

Paper authors

1. McGinness, Lachlan;
2. Dührkoop, Susanne;
3. Jansky, Alexandra;
4. Keller, Oliver;
5. Lorenz, Ankatrin;
6. Schmeling, Sascha;
7. Wendt, Klaus;
8. Woithe, Julia;

Paper author roles and affiliations

1. CERN, European Organization for Nuclear Research, Geneva, Switzerland and Physics Education Centre, Australian National University
2. CERN, European Organization for Nuclear Research, Geneva, Switzerland
3. CERN, European Organization for Nuclear Research, Geneva, Switzerland and Austrian Educational Competence Centre Physics, University of Vienna, Austria
4. CERN, European Organization for Nuclear Research, Geneva, Switzerland
5. Albert Ludwig University of Freiburg, Germany
6. CERN, European Organization for Nuclear Research, Geneva, Switzerland
7. Johannes Gutenberg University, Mainz, Germany
8. CERN, European Organization for Nuclear Research, Geneva, Switzerland

Abstract

Quadrupole ion traps are modern and versatile research tools used in mass spectrometers, in atomic frequency and time standards, in trapped ion quantum computing research, and for trapping anti-hydrogen ions at CERN. Despite their educational potential, quadrupole ion traps are seldom introduced into the physics classroom not least because commercial quadrupole ion traps appropriate for classroom use are expensive and difficult to set up. We present an open hardware 3D-printable quadrupole ion trap suitable for the classroom, which is capable of trapping lycopodium spores.

The quadrupole ion trap operates using a 3 kV 50 Hz alternating current power supply and uses an astable multivibrator circuit including high luminosity LEDs to illuminate the spores, using the stroboscopic effect to exhibit their movement.

The trap can be used in teaching laboratories to enhance high school and university students' understanding of electric fields and their applications.

Metadata Overview

Design files & accompanying documents: DOI 10.5281/zenodo.1251787

Link: <https://zenodo.org/record/1251787#.Wzxt9lzaUk>

Target group: secondary school students, undergraduate students, and their teachers

Skills required: Desktop 3D printing - easy; Point to Point breadboard construction - easy

Replication: For example, a master's thesis on DIY construction of quadrupole ion traps is available in German [3]. Commercial versions of the project can be purchased at Newtonian Labs and LD Didactic [8, 13]. Future versions of designs may be found at DOI

10.5281/zenodo.1251786

See section "Build Details" for more detail.

Keywords

Physics Education; Quadrupole Ion Trap; Paul Trap; Particle Trap.

Introduction

3D printing and 'making' in an educational context has become more prevalent and 3D printers are becoming more widespread in schools and universities throughout Europe, America and Australia [7, 10, 12]. There is also increasing focus on modern physics and particle physics in high school curricula [1, 2, 5]. However, particle physics can be an abstract topic as there are a limited number of hands-on experiments that students can perform.

One type of a 'hands-on' experiment that students can perform is the construction of particle traps such as the quadrupole ion trap. Wolfgang Paul and Hans George Dehmelt developed

PAUL TRAP

Everything is available online at:

<https://zenodo.org/record/1251787#.Wz9bHNIzaUk>

PARTICLE IDENTITIES

Online Game where you can determine what type of particle fits your personality best:

cern.ch/go/fh9J



INTRODUCING SEMICONDUCTORS TO HIGH SCHOOL STUDENTS

WG2 S'Cool LAB 2

Ani Torres, Eirini Siotou, Erkan Akar, Mieke Geussens,
Nteta Nfon

Supervisor : Susanne Duehrkoop



HST S`COOL LAB WORKING GROUP 2

SEMICONDUCTORS AT CERN

- Experience how Semiconductors can be introduced at school
- Use hands-on low cost experiments to discover different functional circuits
- Create your own model for school, explaining the use of semiconductors at CERN

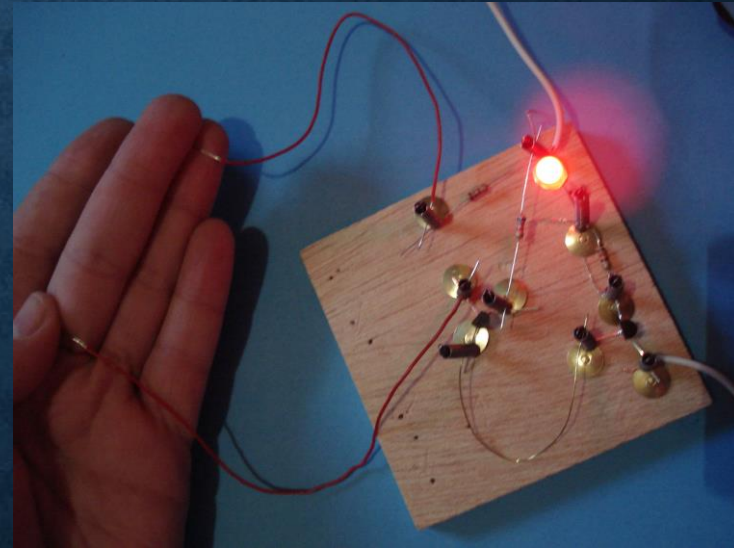
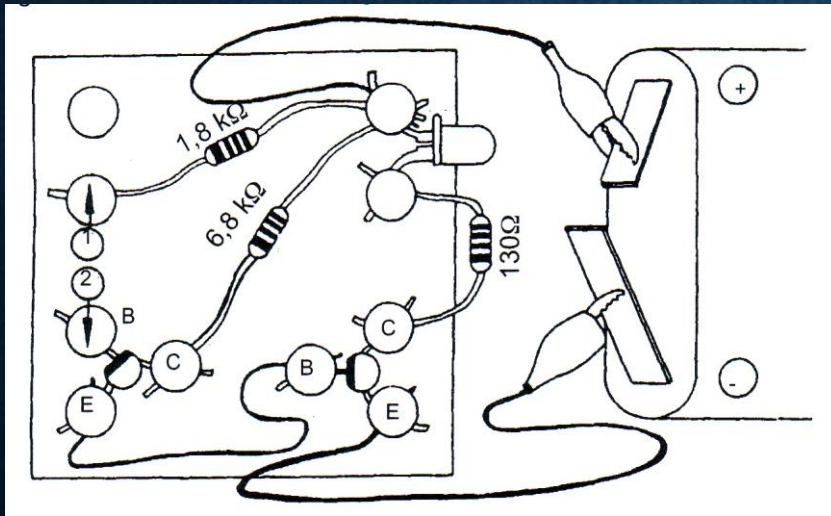

Sensor switch

AIM : GO FROM ZERO KNOWLEDGE TO BUILD LOW COST PARTICLE DETECTORS USING SEMICONDUCTORS

Radiation detector

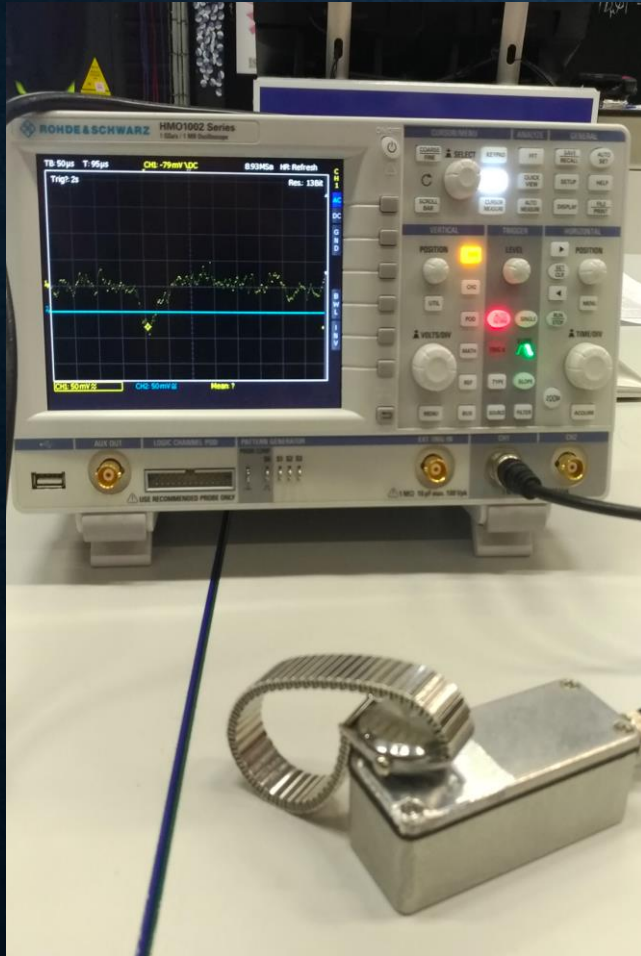

Light sensor

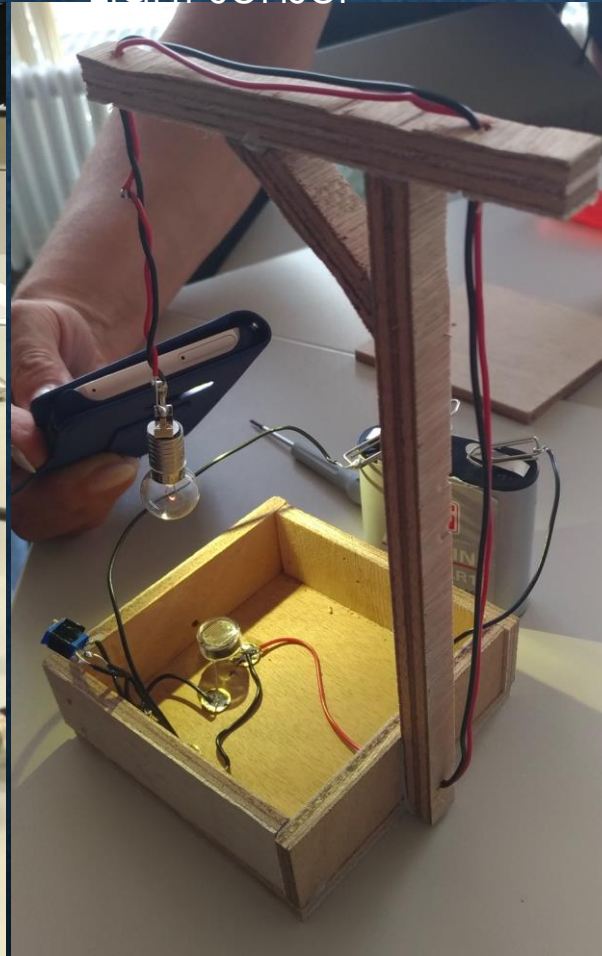

Home made Geiger Müller

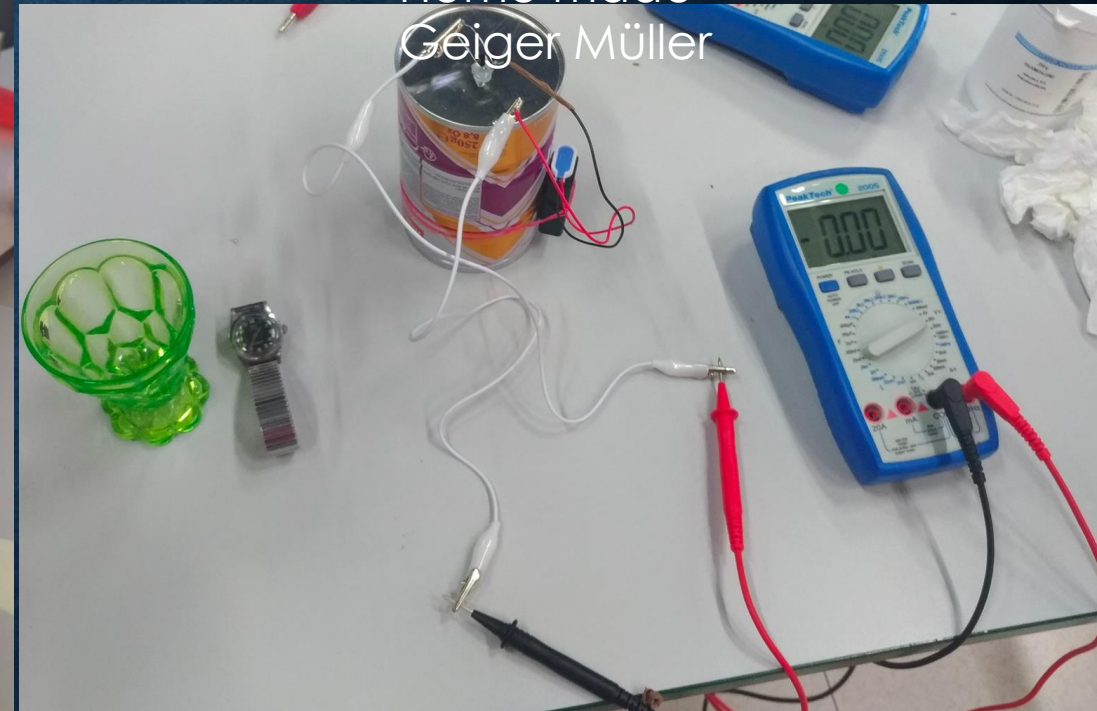

KAPITEL 4: TEACHER IN RESIDENCE

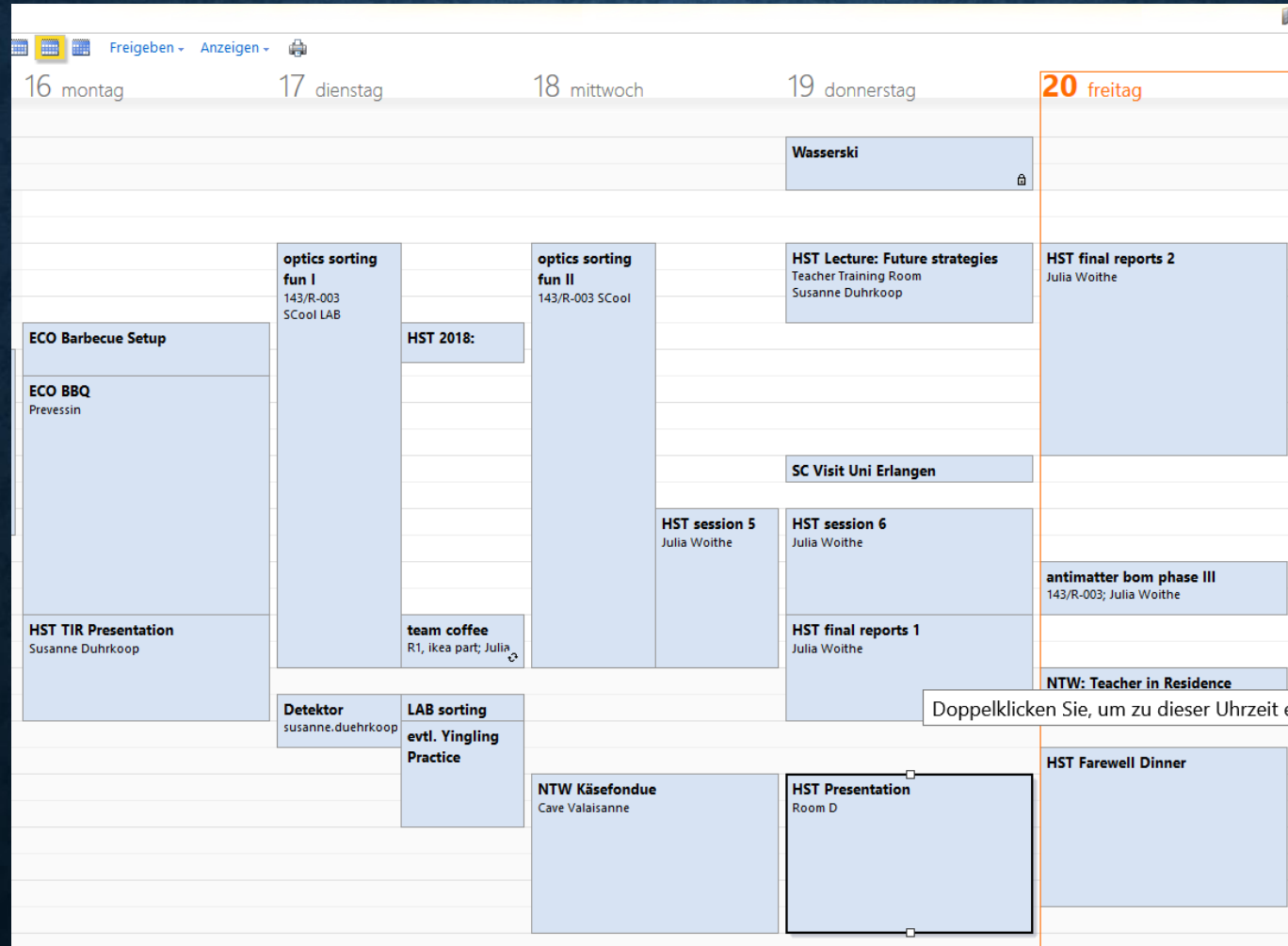

KAPITEL 5: EIN LEBEN NACH DEM CERN

