



Possible further simplification of the matching section

R. De Maria, D. Gamba

Thanks to G. Arduini, R. Calaga, F. Cerutti, S. Fartoukh, P. Fessia, F. Galan, M. Giovannozzi, L. Medina, H. Prin, E. Todesco, R. Tomas.

HL-LHC Baseline Orbit corrector layout

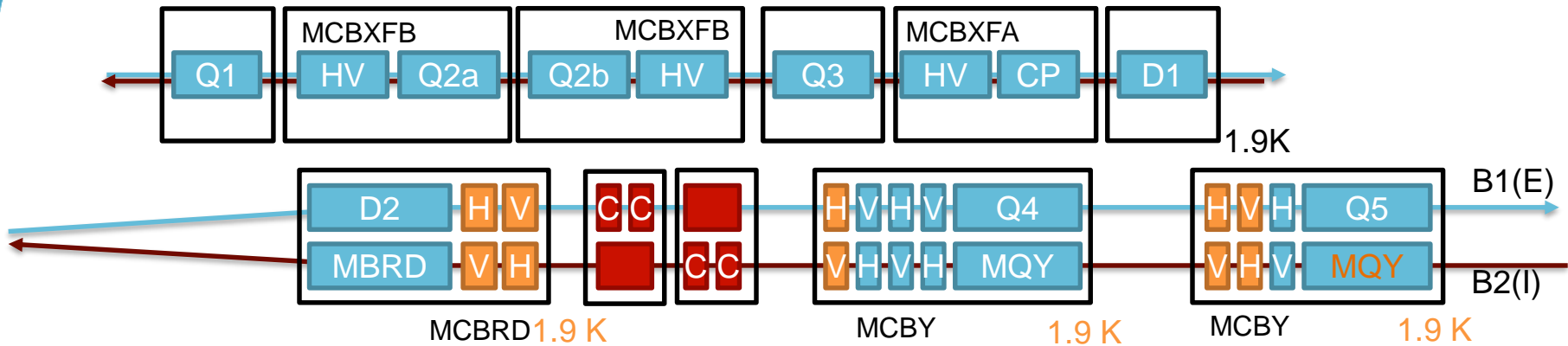

HL-LHC baseline designed to:

- Provide HV crossing plane in both Point 1, 5: compatible with flip of crossing plane and potential installation of 2 additional crab cavities.
- Control orbit at the crab cavities in the HV planes independently from the IP.
- Adjust the IP position limiting the realignment of HW components (crab cavities only).
- Correct quadrupole misalignments and dipole tilt and transfer function errors based on LHC experience.
- **Need flexible bellows in between crab cavities not yet in baseline.**

To reduce the number of correctors we need to change the design criteria.

HL-LHC Option 1 Orbit corrector layout

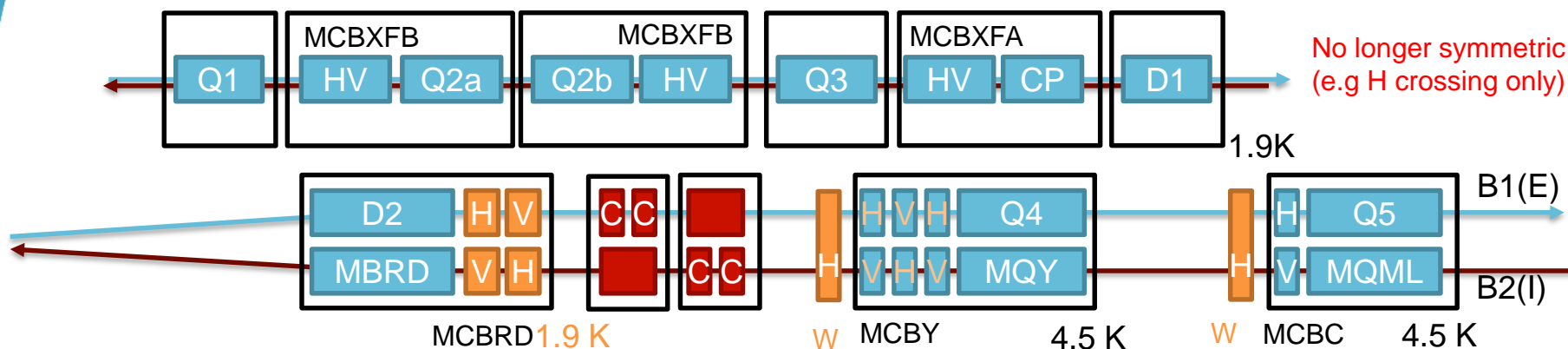

HL-LHC Option 1 designed to :

- **Freeze** HV crossing plane in both Point 1, 5: **not** compatible with flip of crossing plane and potential installation of 2 additional crab cavities
- Control orbit at the crab cavities in the **crossing planes only** independently of the IP
- Adjust the IP position limiting the realignment of HW components (crab cavities only).
- Correct quadrupole misalignments and dipole tilt and transfer function errors based on LHC experience.
- **Need flexible bellows in between crab cavities not yet in baseline.**

Layout changes with respect to the baseline:

- Q4: removing 1 corrector, reusing existing cold mass (needs rotation), no need of 1.9 K, **additional warm corrector (1.3 Tm in plane of crossing)**.
- Q5: removing 2 correctors, reusing existing Q5 cold mass **additional warm corrector (0.9 Tm in plane of crossing)**, no need of 1.9 K

HL-LHC Option 2 Orbit corrector layout

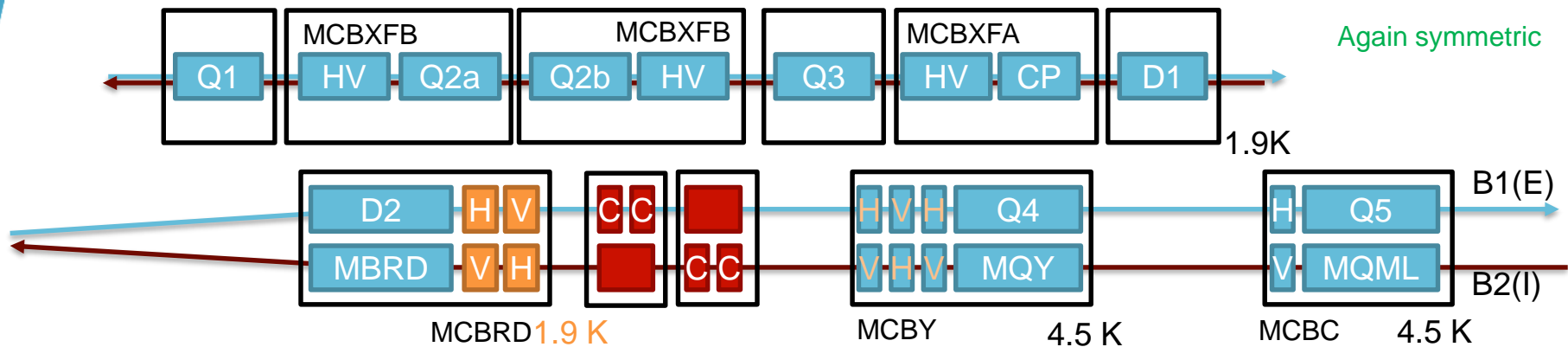

HL-LHC Option 2 designed to:

- Implement full remote alignment system usable with safe beams.
- Provide HV crossing plane in both Point 1, 5: compatible with flip of crossing plane and potential installation of 2 additional crab cavities.
- Control position of the crab cavities w.r.t beam **using remote alignment system.**
- Adjust the IP position **using remote alignment system and small fraction of orbit correctors.**
- **No need of flexible bellows in the crab cavities (thanks to crossing closed in D2, IP offset with alignment).**
- Correct quadrupole misalignments and dipole tilt and transfer function errors based on LHC experience (**potential improvement using full remote alignment system with safe beam.**)

Changes with respect to the baseline

- Q4: removing 1 corrector, reusing existing cold mass (needs rotation), no need of 1.9 K.
- Q5: removing 2 correctors, reusing existing Q5 cold mass, no need of 19 K.
- Full deployment of remote alignment system to be used with safe beam.

Orbit baseline corrector budget

Right Point 5, H crossing, 2σ strength for errors

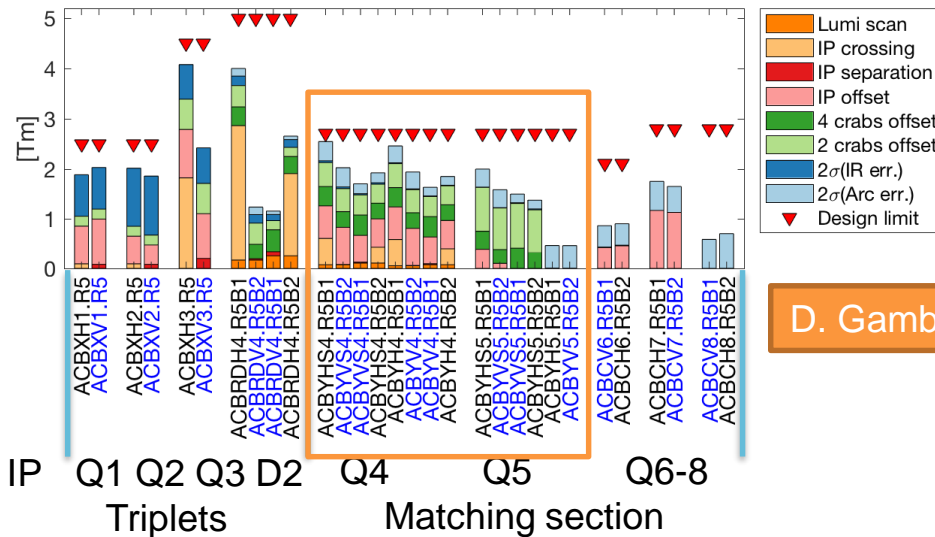

For the Left and Point 1 symmetries applies:

- Left B1 -> Right B2,
- Left B2 -> Right B1
- H Point 5 -> V Point 1

Knobs (Horizontal and Vertical):

- **IP crossing** ($\pm 250 \mu\text{rad}$), **separation** ($\pm 0.75 \text{ mm}$), **offset:** ($\pm 2.0 \text{ mm}$)
- **Luminosity** scan (individual beam IP shift of $\pm 100 \mu\text{m}$)
- beam alignment in the crab cavities: 2 cavities (offset, separation ± 0.5 different beam both planes), 4 cavities (offset same beam $\pm 0.25 \text{ mm}$ both planes).

Machine errors (**uniformly distributed, uncorrelated**):

- **0.5 mm max** transverse displacement of quadrupoles at the IT (**IR. err.**)
- **0.5 mm max** transverse displacement of quadrupoles in the arc (**Arc. err.**).
- **10 mm max** longitudinal displacement, **0.5 mrad max** roll, **0.2% max** field error for D1 and D2 (**IR err.**) and in the arcs (**Arc err.**).

Orbit baseline corrector budget

Right Point 5, H crossing, 2σ strength for errors

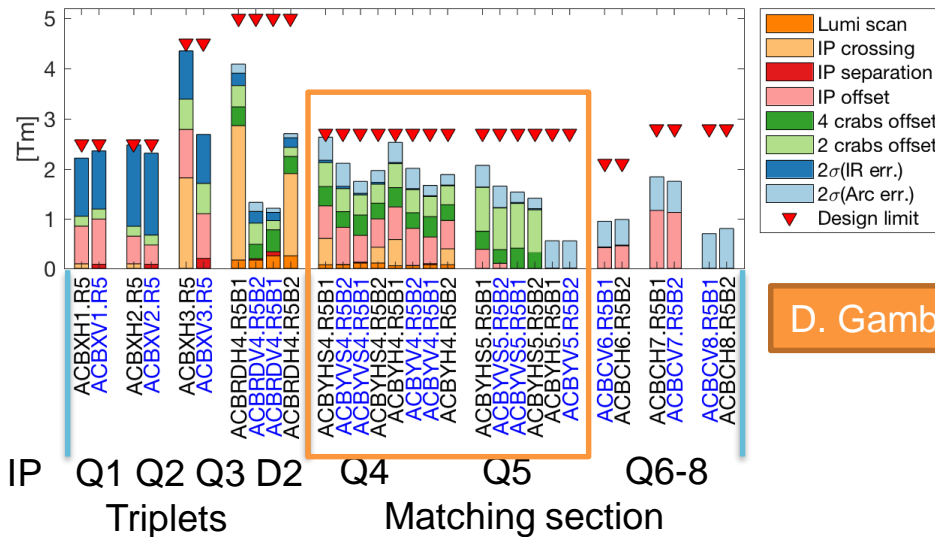

D. Gamba

For the Left and Point 1 symmetries applies:

- Left B1 -> Right B2,
- Left B2 -> Right B1
- H Point 5 -> V Point 1

Knobs (Horizontal and Vertical):

- **IP crossing** ($\pm 250 \mu\text{rad}$), **separation** ($\pm 0.75 \text{ mm}$), **offset**: ($\pm 2.0 \text{ mm}$)
- **Luminosity** scan (individual beam IP shift of $\pm 100 \mu\text{m}$)
- beam alignment in the crab cavities: 2 cavities (offset, separation ± 0.5 different beam both planes), 4 cavities (offset same beam $\pm 0.25 \text{ mm}$ both planes).

Machine errors (**uniformly distributed, uncorrelated**):

- **0.7 mm max** transverse displacement of quadrupoles at the IT (**IR. err.**)
- **0.6 mm max** transverse displacement of quadrupoles in the arc (**Arc. err.**).
- **10 mm max** longitudinal displacement, **0.5 mrad max** roll, **0.2% max** field error for D1 and D2 (**IR err.**) and in the arcs (**Arc err.**).

Orbit Option 1 corrector budget

Right Point 5, H crossing, 2σ strength for errors

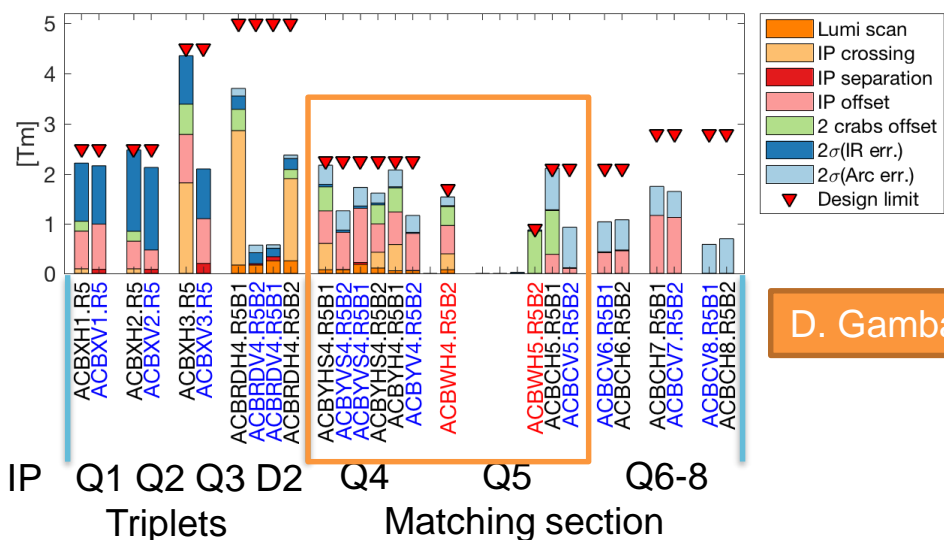

D. Gamba

For the Left and Point 1 symmetries applies:

- Left B1 -> Right B2,
- Left B2 -> Right B1
- H Point 5 -> V Point 1

Knobs (Horizontal and Vertical):

- IP **H crossing** ($\pm 250 \mu\text{rad}$), **V separation** ($\pm 0.75 \text{ mm}$), **offset**: ($\pm 2.0 \text{ mm}$)
- **Luminosity** scan (individual beam IP shift of $\pm 100 \mu\text{m}$)
- beam alignment in the crab cavities: 2 cavities (offset, separation ± 0.5 different beam **crossing plane only**)

Machine errors (**uniformly distributed, uncorrelated**):

- **0.7 mm max** transverse displacement of quadrupoles at the IT (**IR. err.**)
- **0.5 mm max** transverse displacement of quadrupoles in the arc (**Arc. err.**).
- **10 mm max** longitudinal displacement, **0.5 mrad max** roll, **0.2% max** field error for D1 and D2 (**IR err.**) and in the arcs (**Arc err.**).

Orbit Option 2 corrector budget

Right Point 5, H crossing, 2σ strength for errors

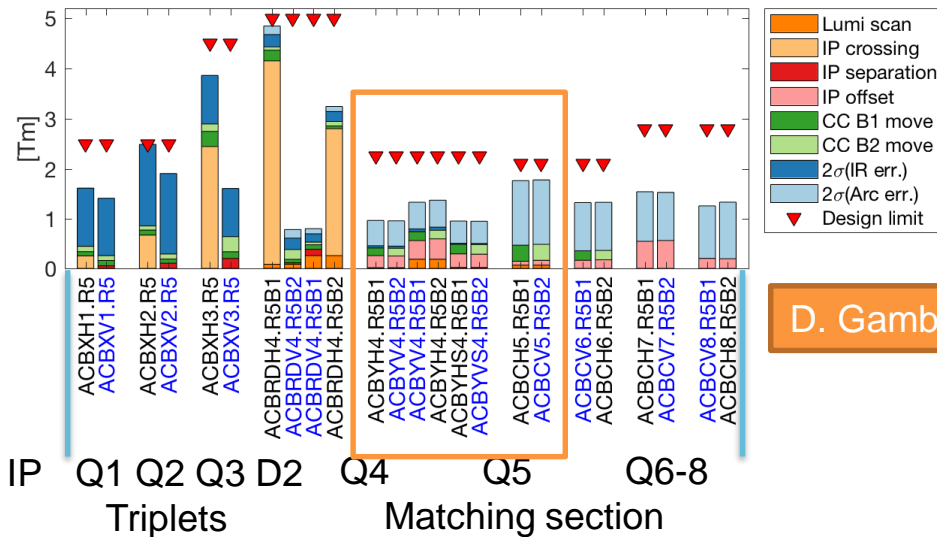

D. Gamba

For the Left and Point 1 symmetries applies:

- Left B1 -> Right B2,
- Left B2 -> Right B1
- H Point 5 -> V Point 1

Knobs (Horizontal and Vertical):

- **IP crossing** ($\pm 250 \mu\text{rad}$), **separation** ($\pm 0.75 \text{ mm}$), **offset** ($\pm 2.0 \text{ mm}$) using remote alignment capabilities, **crossing angle fully closed in D2 no crab flexible bellows.**
- **Luminosity** scan (individual beam IP shift of $\pm 100 \mu\text{m}$)
- **Limited** beam alignment in the crab cavities: 2 cavities (individual orbit adjust $\pm 0.5 \text{ mm}$ beam both planes) (**knob up to Q6**) to complement remote alignment.

Machine errors (**uniformly distributed, uncorrelated**):

- **0.7 mm max** transverse displacement of quadrupoles at the IT (**IR. err.**)
- **0.9 mm max** transverse displacement of quadrupoles in the arc (**Arc. err.**).
- **10 mm max** longitudinal displacement, **0.5 mrad max** roll, **0.2% max** field error for D1 and D2 (**IR err.**) and in the arcs (**Arc err.**).

Alignment scenarios

- LHC design: one realignment per YTS better than 0.5 mm (LHC PR 1007 Note).
- LHC experience: one realignment per LS (resulting in IP CMS off by 1.5 mm) due to no tilt monitoring and time consuming procedures.
- HL-LHC design baseline: one realignment per YTS better than 0.5 mm with full monitoring and quick and clean procedure.
- HL-LHC design Option 2: one realignment per YTS and possibility to realign during a TS (2.5 mm stroke) with fine tuning during commissioning time (resolution 0.1 mm).

Still needed for Option 2:

- Full alignment of vacuum equipment in between TAXN and D2
- Allocate budget for cabling
- Demonstrate feasibility of flexible wave guides for crab cavities
- Proof of principle demonstration in a machine (e.g. SPS or LHC)

To be checked with Survey Team

Alignment of Crab Cavity

- Crab cavity RF individual center will be aligned better than 0.5 mm (3σ) (M. Sozin)
- Tolerance beam with respect to RF center of ± 1.0 mm in the crossing plane (R. Calaga). Therefore ± 0.5 residual orbit margin.
- Keep operational crab cavity 0.5 mm in the crossing plane.

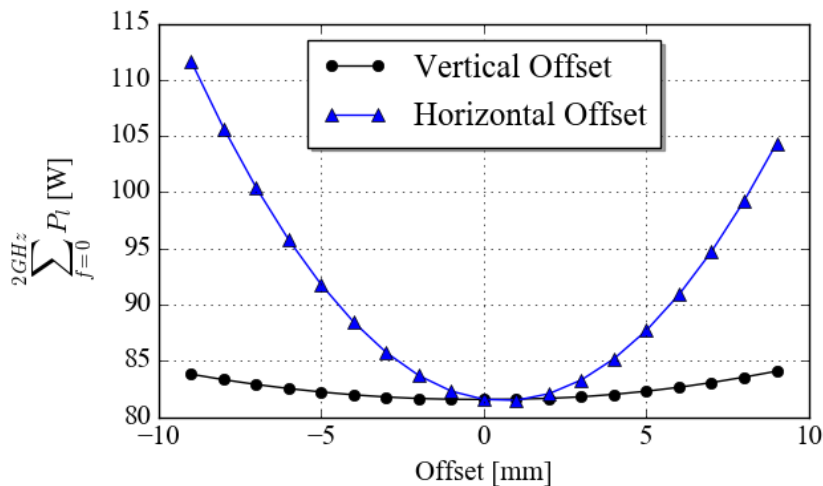

HOM only, no main mode
R. Calaga 12/1/2018

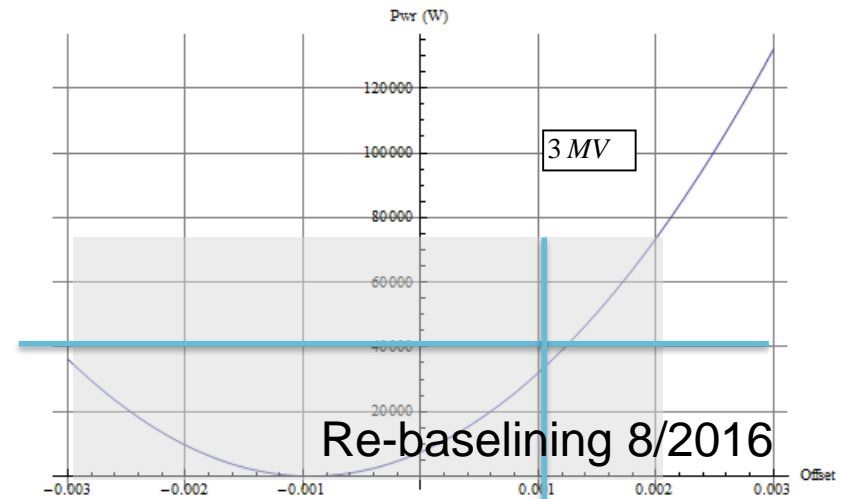

P. Baudrenghien
21/3/2014

1 mm

Is there any emittance growth due to HOM?

IP shift with remote alignment

Alignment needed before the run and after possible request of IP shift from the experiment.

1. Baseline knob: move the cavities (large shift, large shear), aperture loss, orbit corrector strength loss, needs flexible bellows in between crab cavities (cost, space, impedance)

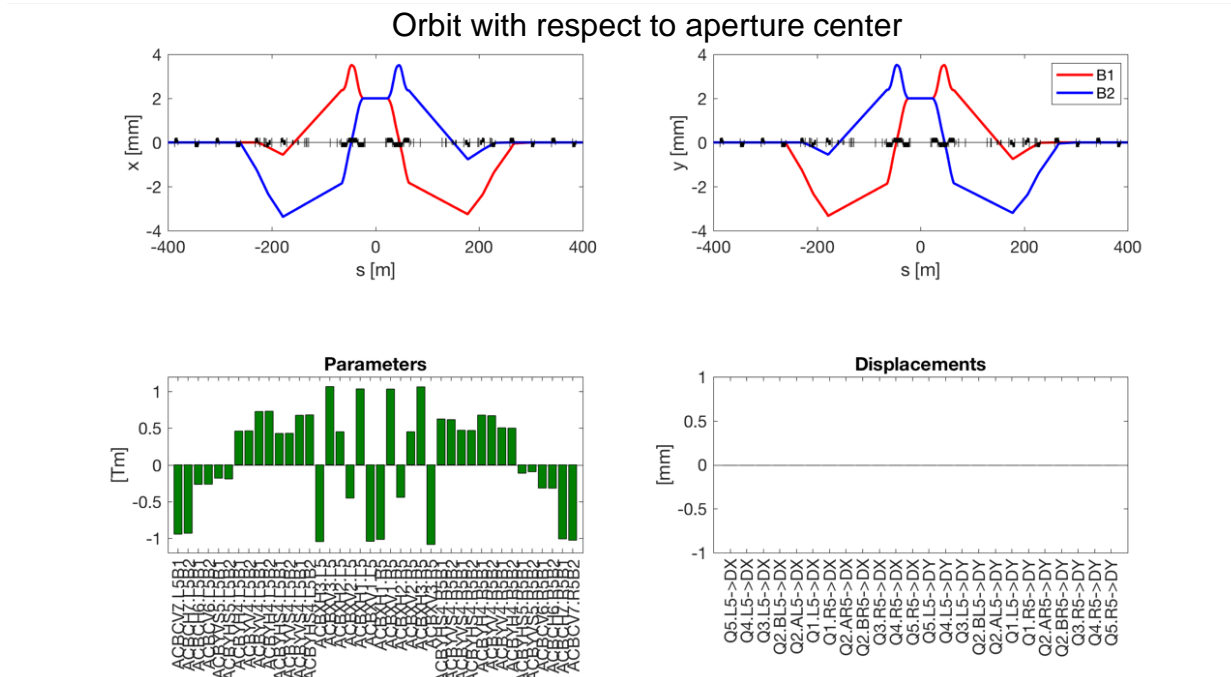

Similar to what is done in LHC for CMS and Alice

IP shift with remote alignment

Alignment needed before the run and after possible request of IP shift from the experiment.

1. Baseline knob: move the cavities (large shift, large shear), aperture loss, orbit corrector strength loss, needs flexible bellows in between crab cavities (cost, space, impedance)
2. Option 2: Long re-alignment: move everything. no shear, no aperture loss in Q1-Q4, very limited orbit corrector usage.

Orbit with respect to aperture center

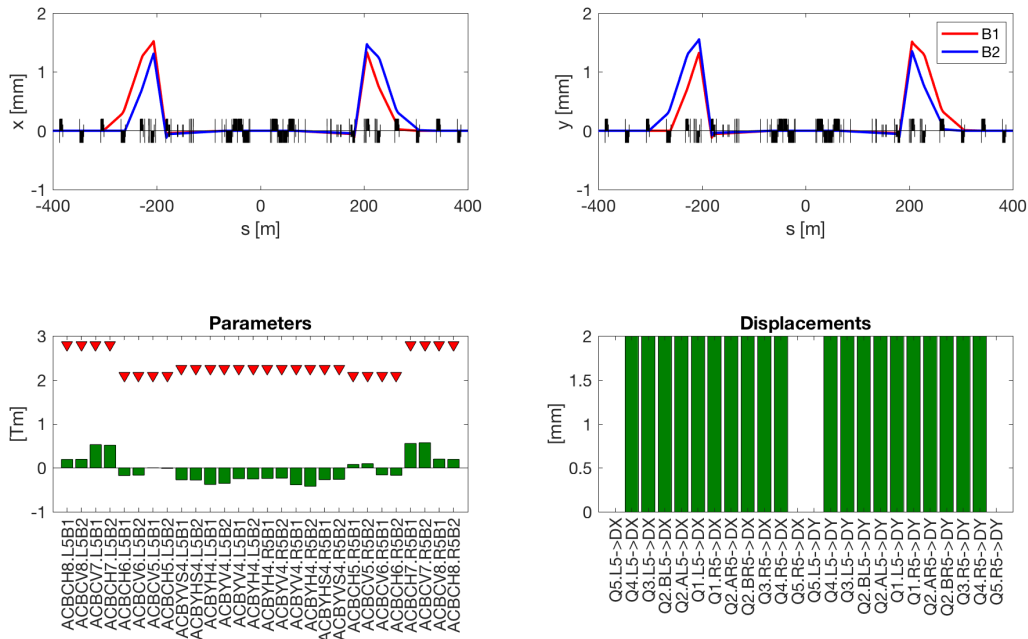

No loss of aperture from Q1 to Q4

IP shift with remote alignment

Alignment needed before the run and after possible request of IP shift from the experiment.

1. Baseline knob: move the cavities (large shift, large shear), aperture loss, orbit corrector strength loss, needs flexible bellows in between crab cavities (cost, space, impedance)
2. Option 2: Long re-alignment: move everything. no shear, no aperture loss in Q1-Q4, very limited orbit corrector usage.
3. Option 2: Short re-alignment: move only triplets, some shear (0.4 mm) to be allocated in the bellows, some aperture loss in Q1-Q3 and Q5-Q6.

Orbit with respect to aperture center

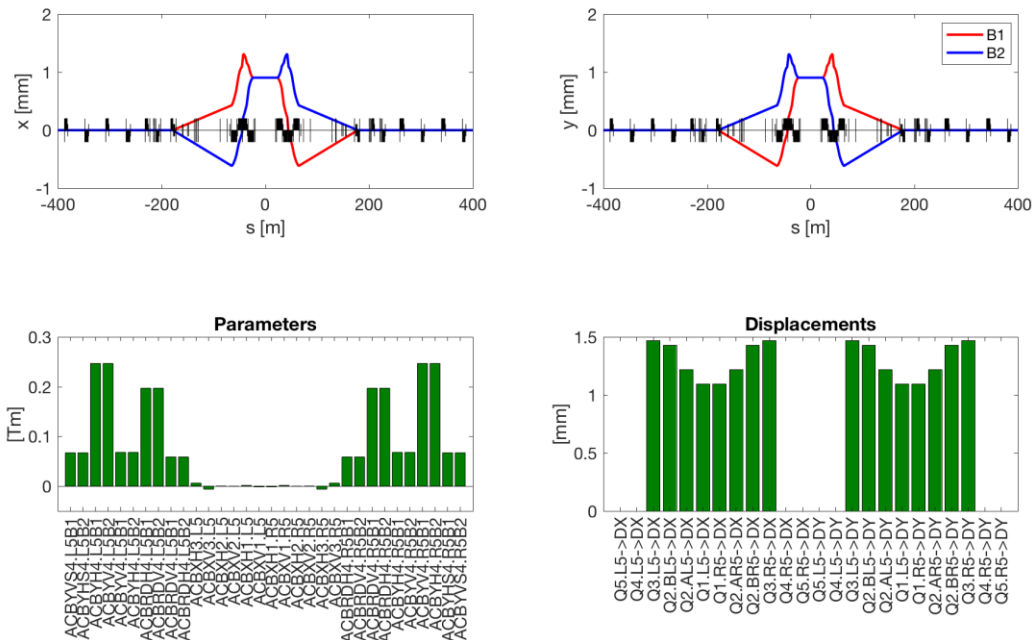

Apertures

	Base	Opt. 1	Opt. 2 ¹	Base	Opt. 1	Opt. 2
	Round $\beta^*=15$ cm			Flat $\beta^*=7.5$ cm		
TAXS	16.3	16.3	16.3/16.3	14.0	14.0	14.0/14.0
Triplets	12.0	12.0	12.6/13.1	11.8	11.8	12.3/12.7
TAXN	15.4	15.4	17.1/17.3	12.4	12.4	13.7/13.9
D2	15.5	15.5	18.3/18.6	12.9	12.9	14.6/14.7
Q4	14.5	14.5	18.3/18.3	10.4	10.4	13.0/13.0
Q5	24.8	17.3	20.7/18.7	17.6	12.4	14.6/14.3
Q6	25.5	26.8	27.9/25.9	18.0	18.0	19.8/19.3

Requirements
 $>12 \sigma$ with TCT and phase $<30^\circ$
 $> 14.6 \sigma$ with TCT and any phase
 $>18 \sigma$ without TCT

R. Bruce et al.
 ATS Note

Option 2 with short IP offset brings:

- round: less stringent MKD-TCT phase advance or further β^* reduction,
- recover full flat optics potential² lost with last re-baselining.

¹short offset/long IP offset correction

²virt. lumi: +26% or 50% with or without CC L. Medina, 7th annual meeting.

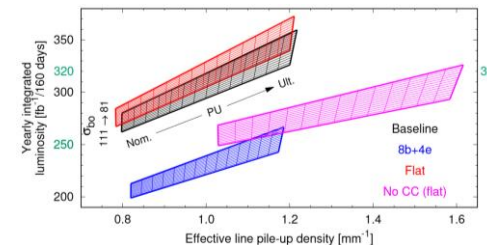

Additional benefits of remote alignment system

- Reduction of the residual orbit after transverse misalignment correction from 2 mm (present assumption) to 0.1 mm [1]
- Aperture benefits in between 0.5σ to 2σ depending on the element.

Need to prove that a procedure exists to know the correct displacement to apply to the quadrupoles to reduce residual orbit and orbit corrector strength.

Most of the ingredient already tested:

- [1] L. van Riesen-Haupt, et al., “K-Modulation Developments via Simultaneous Beam Based Alignment in the LHC”, IPAC17, TUPVA042.
- [2] R. Tomás, et al., “Ballistic optics”, LMC meeting – May 10, 2017.
- [3] M. Hostettler, et al., “Impact of the Crossing Angle on Luminosity Asymmetries at the LHC in 2016 Proton Physics Operation” IPAC17, TUPVA005.

Unfortunately test with beam is not possible unless re-alignment capabilities restored in the LHC (e.g. tilt monitoring).

Open issues

Warm correctors

- New designs for 70 mm aperture
- Need to check space for power converter (~600A)
- Very long and bulky (could help with radiation though)

Reduced aperture in Q5

- Check energy deposition

Increased temperature in Q4 – Q5

- Check integration for QRL

To be checked with Integration and Energy Deposition Working Packages

Summary

	Baseline	Option 1	Option 2
Full HV symmetry	Yes	No	Yes
Build new MCBY	Yes	No	No
Reuse Q4/5 cold mass	No	Yes	Yes
Add warm corrector	No	Yes	No
Aperture bottlenecks	Triplet/Q4	Triplet/Q4	Triplet
Alignment with beam	No	No	Yes
β^* reach	Same	Same	Improved
Crab flexible bellows	Yes	Yes	No
Transverse residual misalign.	0.7/0.6	0.7/0.5	0.7/0.9 or better
Additional radiation in Q5	No	tbc	tbc
TCT.6 mandatory	No	Yes	Yes

Back-up

Orbit correctors: LHC Experience

Orbit correctors near the experiments are needed to:

- Correct the orbit from quadrupole misalignment and transfer function errors
- Implement crossing angle and separation bumps
- Implement IP adjustment for luminosity optimization

Left Point 5: Typical physics fill

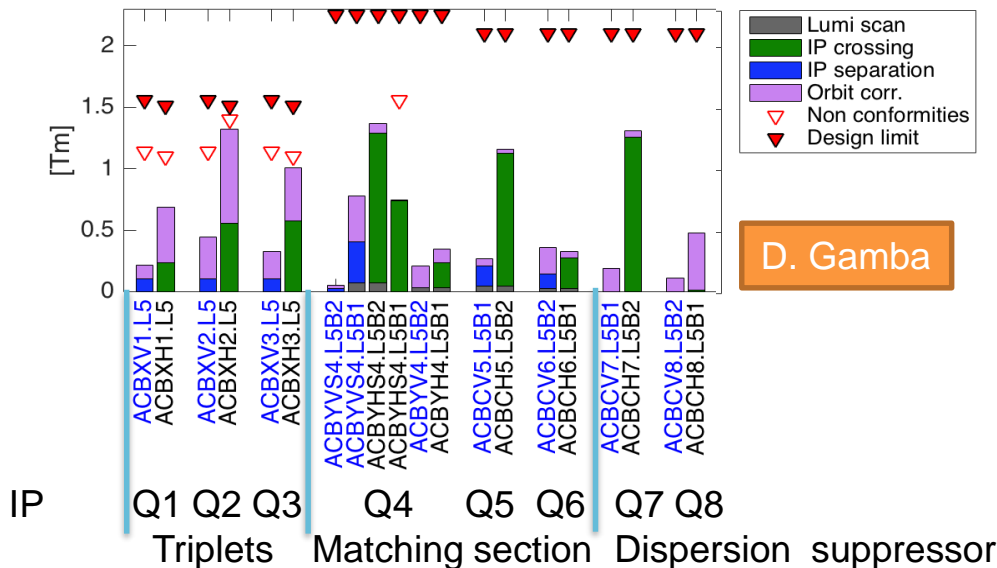

D. Gamba

Available strength of the orbit correctors in the LHC:

- Can correct for the worst case scenarios for the expected imperfections
- Gives margins to be used for non-conformities

Present LHC experience shows:

- 2σ of a uniform distribution of expected imperfections reproduces the present average usage of the correctors
- Outliers at the strength limit are anyway present due to non-conformities

When available margins used for unanticipated needs (e.g. 2mm shift in IP2, Totem bump, requested shift in IP5)

IP and CC alignment in HLLHC V1.3

The HL-LHC orbit correctors have the budget to provide ± 2 mm offset of the beam in IP1/5 in both planes.

Crab cavities need to be realigned for any change of the average crossing angle and IP position to keep beam loading power below the allowed power. No other re-alignment is needed.

If triplets can be realigned following the IP position, there is a gain in β^* reach and in the required radial displacement of the bellows.

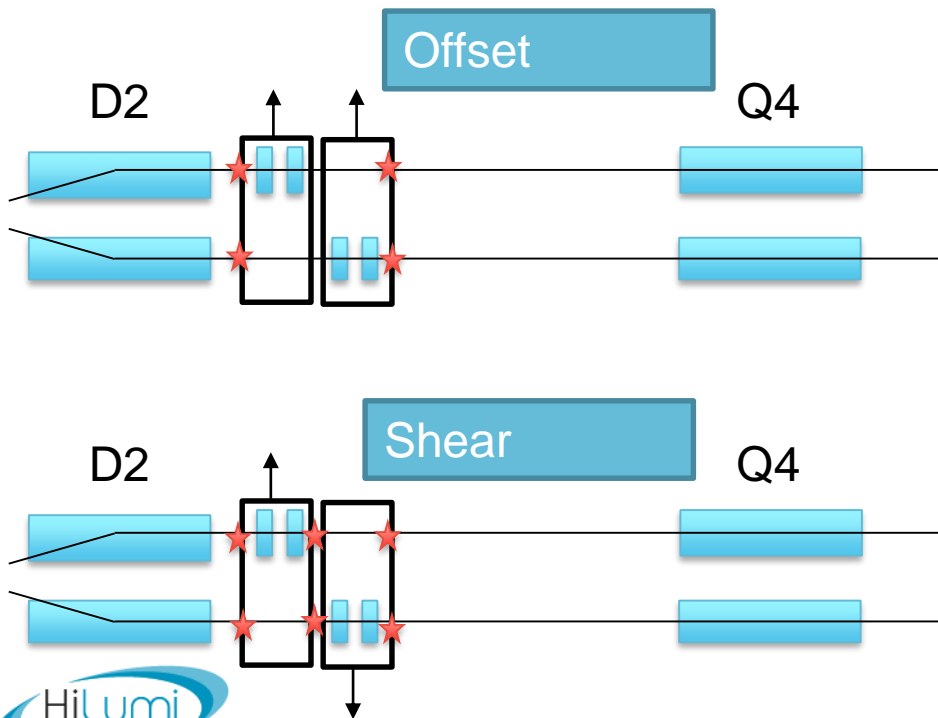

Specification	Offset [mm]	Shear [mm]
Crossing angle	0.3	1.65
IP offset	2.2	2.4
Total	2.5	4.05

Nominal crossing bump

Baseline closed in MCBY.4 (acby.4=0.2 acbrd, $\pm 295 \mu\text{rad}$)

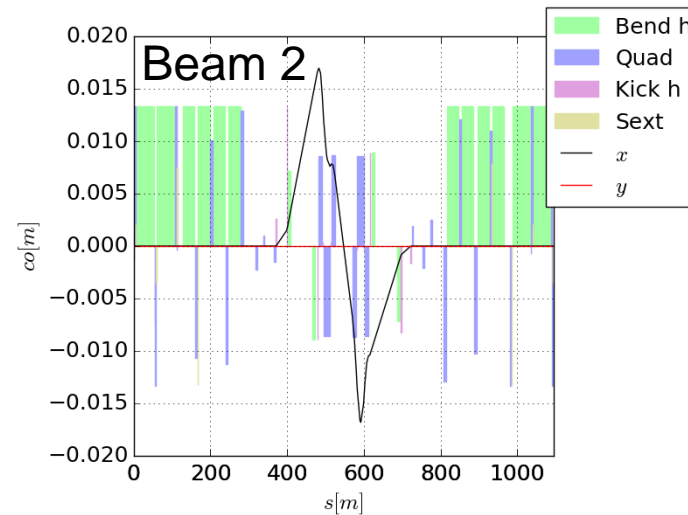
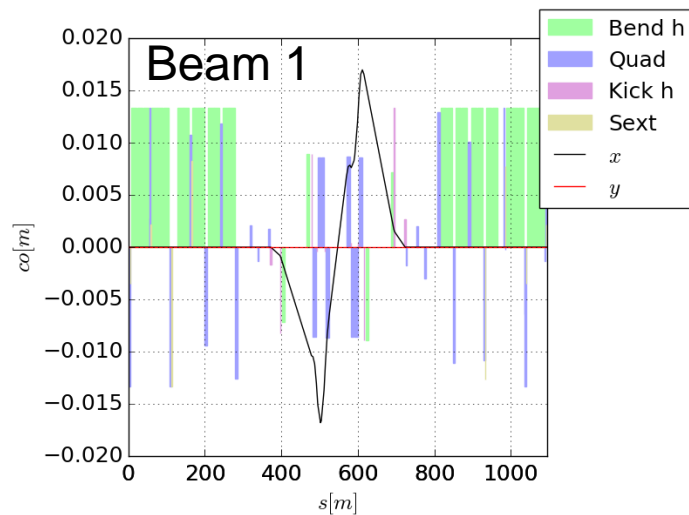

Impact on crab cavity alignment

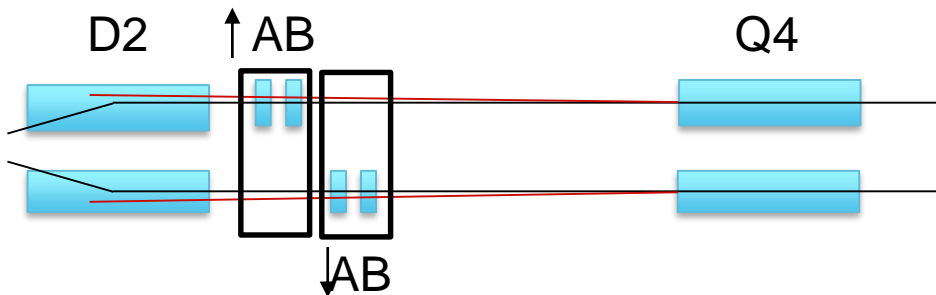

Crossing angle:

$x, y: \pm 1.15 \text{ mm}$ (Beam 1L)

$x, y: \pm(-0.5) \text{ mm}$ (Beam 2)

For cryomodules:

- average offset 0.3 mm
- shear 1.65 mm

Orbit knobs - offset

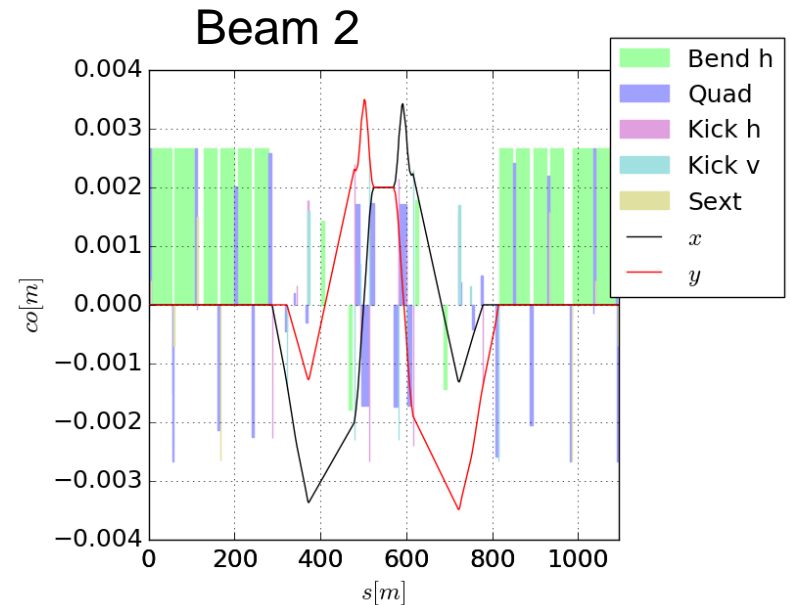
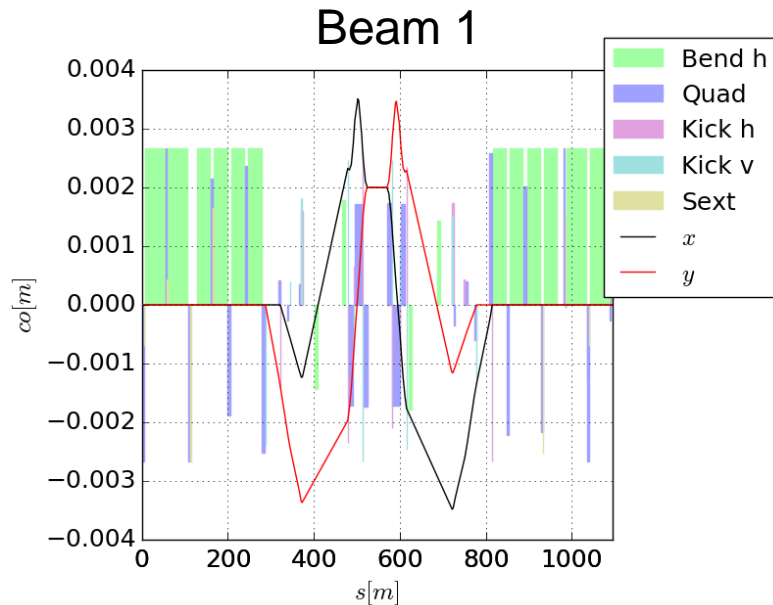

IP Offset knob: $x, y = \pm 2$ mm same for the two beams to accommodate alignment needs of the experiments with machine realignment, besides crab cavities.

IP offset:

$x, y: \pm 3.4$ mm (Beam 1, CD),
 $x, y: \pm 1$ mm (Beam 2, CD),

For cryomodules:

- avg. offset 2.2 mm
- shear 2.4 mm

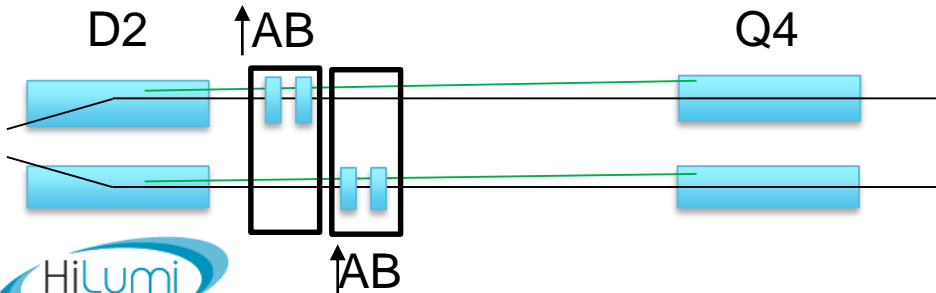

Beam alignment at the CC in HLLHC V1.3

The HL-LHC orbit correctors have the budget to provide a shift of the orbit at crab cavities, independently from the IP, in both planes for :

- ± 0.5 mm average position of Beam 1 and Beam 2
- ± 0.5 mm change of Beam 1 - Beam 2 separation
- ± 0.25 mm change of slope of Beam 1 and Beam 2, independently, useful for 4 cavities per beam, side, point scenarios

This is needed to absorb alignment imperfections in between two realignment campaigns.

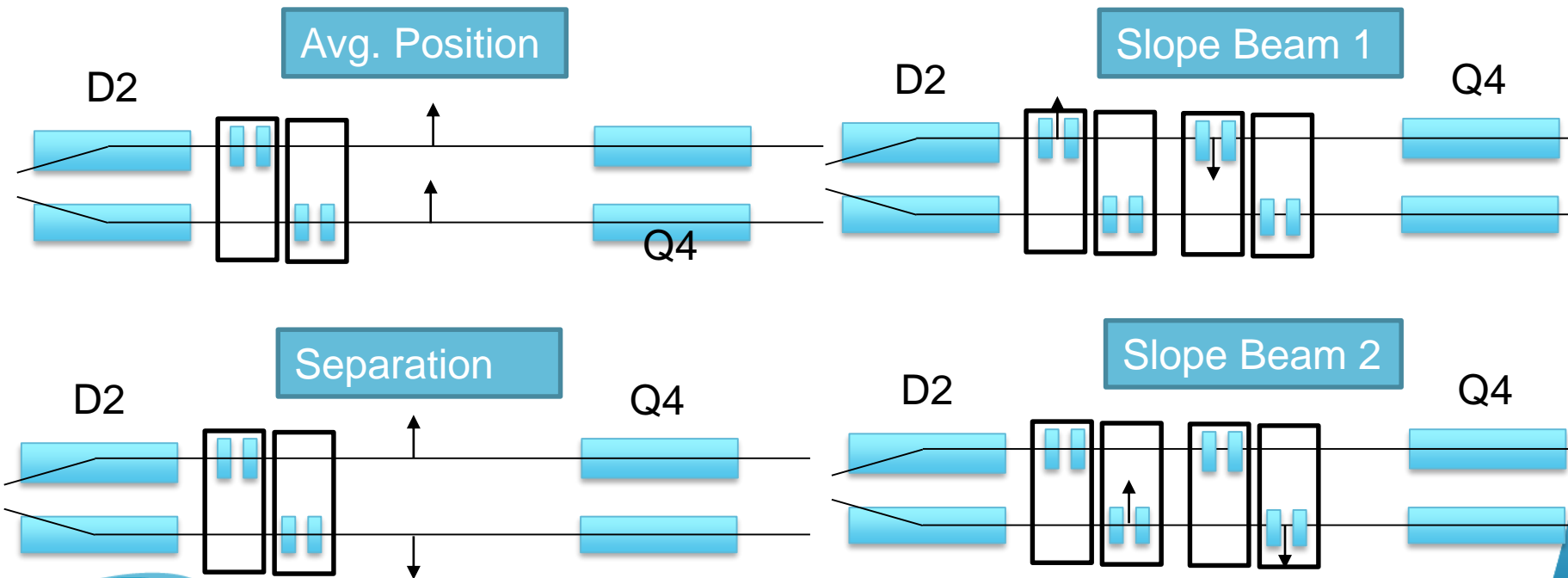

Baseline

Residual orbit (0.7 and 0.6 mm DX/DY...)

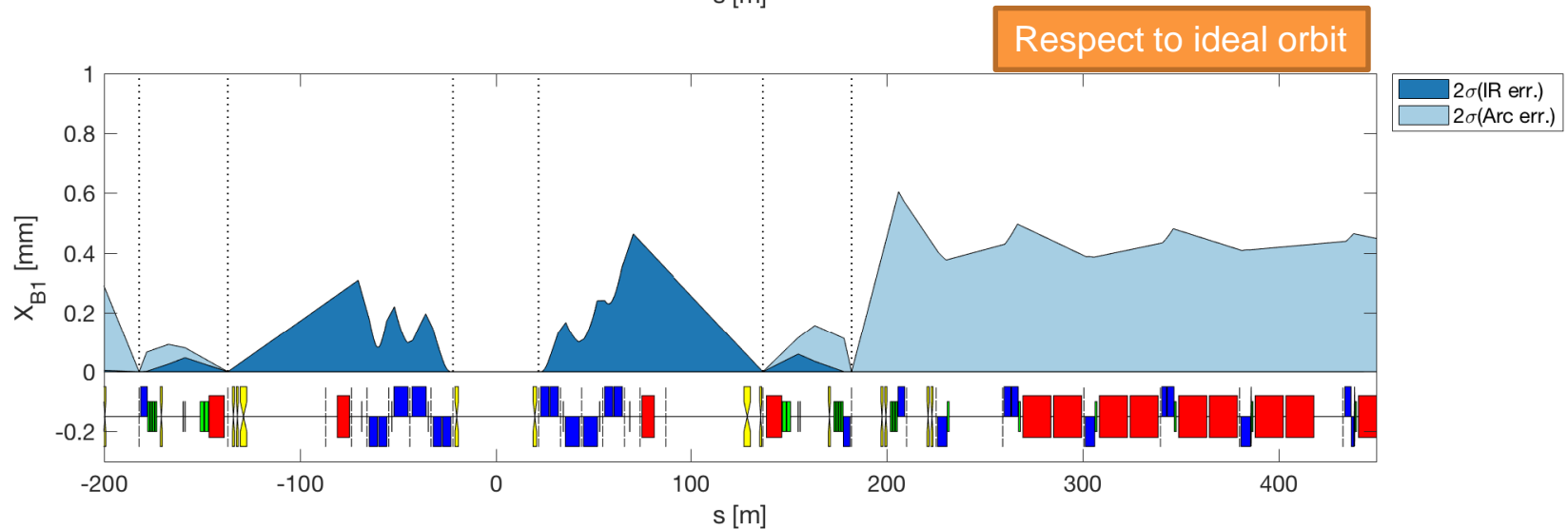
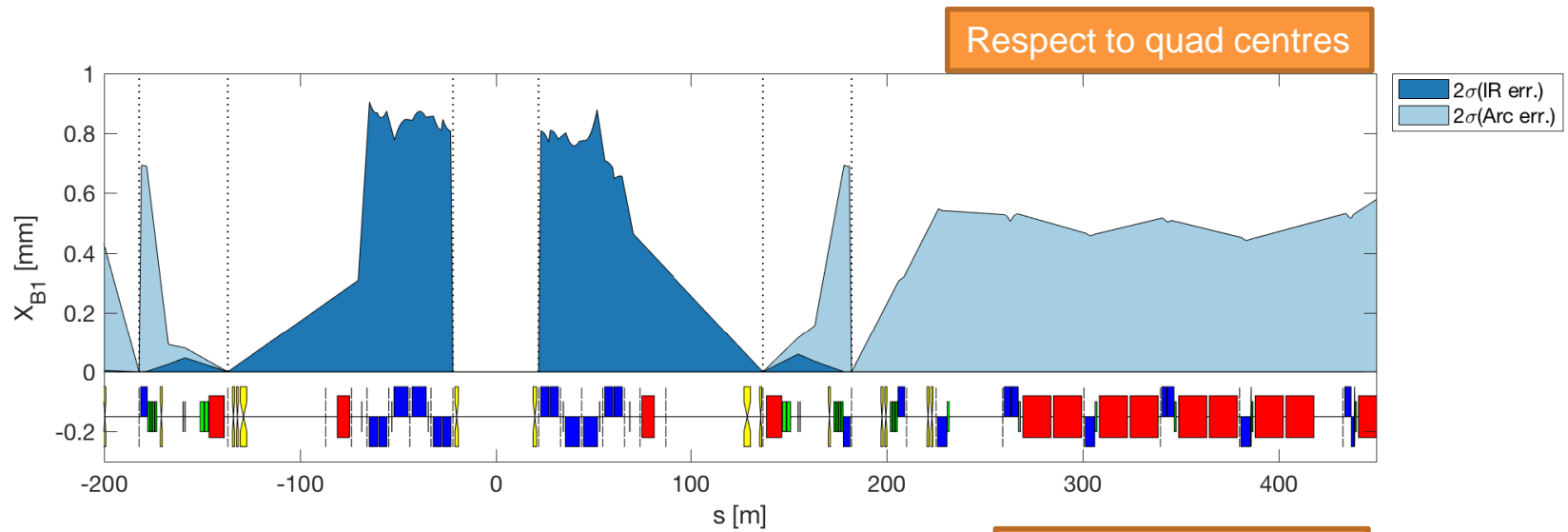

Residual orbit (respect to ideal orbit) [mm]

Element	IR err. [2*std]	Arc err. [2*std]	Lumi scan. [±0.1 mm]	Cros. [±250 μrad]	Sep. [±0.75 mm]	IP Off. [±2 mm]	4 crabs offset	2 crabs offset
TAXS X Y [mm]	0	0	0.1	4.99	0.75	2	0	0.04
MQXFA.[AB]1 X Y [mm]	0.14	0	0.12	9.34	0.91	2.43	0	0.05
MQXFB.[AB]2 X Y [mm]	0.24	0	0.16	14.28	1.2	3.52	0	0.23
MQXFA.[AB]3 X Y [mm]	0.35	0	0.1	14.43	0.82	2.73	0	0.49
MBXF X Y [mm]	0.43	0	0.03	12.96	0.47	2.23	0	0.5
TAXN X Y [mm]	0.06	0	0.14	4.31	0.16	2.91	0	0.88
MBRD X Y [mm]	0.06	0	0.19	2.59	0.1	3.18	0	1.01
MCBRD X Y [mm]	0.08	0.02	0.2	1.25	0.06	3.26	0.04	1.05
MCBY[HV].[AB]?4 X Y [mm]	0.01	0.2	0.02	0.07	0	3.66	0.47	1.05
MQY.4 X Y [mm]	0	0.11	0	0	0	3.52	0.45	0.97
TCLMB.5 X Y [mm]	0.01	0.52	0	0	0	2.97	0.07	0.19
MCBY[HV].[AB]?5 X Y [mm]	0.01	0.63	0	0	0	2.91	0.02	0.09
MQY.5 X Y [mm]	0.01	0.61	0	0	0	2.76	0	0.06
TCLMC.6 X Y [mm]	0	0.53	0	0	0	1.86	0	0.06
MCBC[HV].6 X Y [mm]	0.01	0.55	0	0	0	1.46	0	0.06
MQML.6 X Y [mm]	0	0.54	0	0	0	1.68	0	0.06
MCBC[HV].7 X Y [mm]	0	0.51	0	0	0	0	0	0.09
MQM.[AB]7 X Y [mm]	0	0.5	0	0	0	0.35	0	0.09
MCBC[HV].8 X Y [mm]	0	0.62	0	0	0	0	0	0.24
MQML.8 X Y [mm]	0	0.6	0	0	0	0	0	0.25
MCBC[HV].9 X Y [mm]	0	0.49	0	0	0	0	0	0.27
MQMC.9 X Y [mm]	0	0.45	0	0	0	0	0	0.28
MQM.9 X Y [mm]	0	0.48	0	0	0	0	0	0.28
MCB[HV].10 X Y [mm]	0	0.63	0	0	0	0	0	0.09
MQML.10 X Y [mm]	0	0.61	0	0	0	0	0	0.1

To check

Residual orbit (respect to quad center) [mm]

Element	IR err. [2*std]	Arc err. [2*std]	Lumi scan. [±0.1 mm]	Cros. [±250 μrad]	Sep. [±0.75 mm]	IP Off. [±2 mm]	4 crabs offset	2 crabs offset
TAXS X Y [mm]	0	0	0.1	4.99	0.75	2	0	0.04
MQXFA.[AB]1 X Y [mm]	0.86	0	0.12	9.34	0.91	2.43	0	0.05
MQXFB.[AB]2 X Y [mm]	0.88	0	0.16	14.28	1.2	3.52	0	0.23
MQXFA.[AB]3 X Y [mm]	0.91	0	0.1	14.43	0.82	2.73	0	0.49
MBXF X Y [mm]	0.43	0	0.03	12.96	0.47	2.23	0	0.5
TAXN X Y [mm]	0.06	0	0.14	4.31	0.16	2.91	0	0.88
MBRD X Y [mm]	0.06	0	0.19	2.59	0.1	3.18	0	1.01
MCBRD X Y [mm]	0.08	0.02	0.2	1.25	0.06	3.26	0.04	1.05
MCBY[HV].[AB]?4 X Y [mm]	0.01	0.2	0.02	0.07	0	3.66	0.47	1.05
MQY.4 X Y [mm]	0	0.69	0	0	0	3.52	0.45	0.97
TCLMB.5 X Y [mm]	0.01	0.52	0	0	0	2.97	0.07	0.19
MCBY[HV].[AB]?5 X Y [mm]	0.01	0.63	0	0	0	2.91	0.02	0.09
MQY.5 X Y [mm]	0.01	0.58	0	0	0	2.76	0	0.06
TCLMC.6 X Y [mm]	0	0.53	0	0	0	1.86	0	0.06
MCBC[HV].6 X Y [mm]	0.01	0.55	0	0	0	1.46	0	0.06
MQML.6 X Y [mm]	0	0.57	0	0	0	1.68	0	0.06
MCBC[HV].7 X Y [mm]	0	0.51	0	0	0	0	0	0.09
MQM.[AB]7 X Y [mm]	0	0.56	0	0	0	0.35	0	0.09
MCBC[HV].8 X Y [mm]	0	0.62	0	0	0	0	0	0.24
MQML.8 X Y [mm]	0	0.47	0	0	0	0	0	0.25
MCBC[HV].9 X Y [mm]	0	0.49	0	0	0	0	0	0.27
MQMC.9 X Y [mm]	0	0.6	0	0	0	0	0	0.28
MQM.9 X Y [mm]	0	0.56	0	0	0	0	0	0.28
MCB[HV].10 X Y [mm]	0	0.63	0	0	0	0	0	0.09
MQML.10 X Y [mm]	0	0.45	0	0	0	0	0	0.1

To check

Knobs

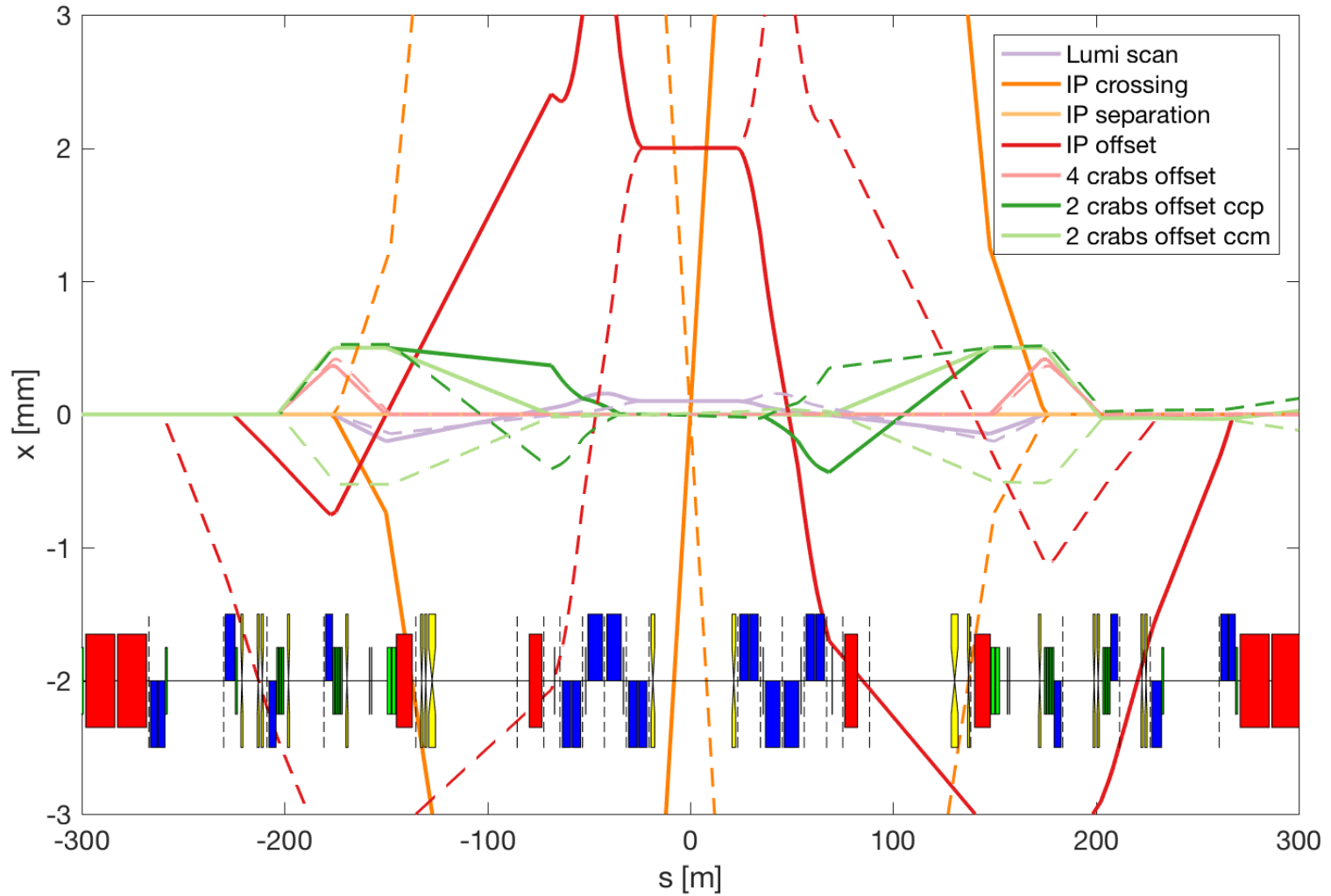

Knobs 1B (H orbit)

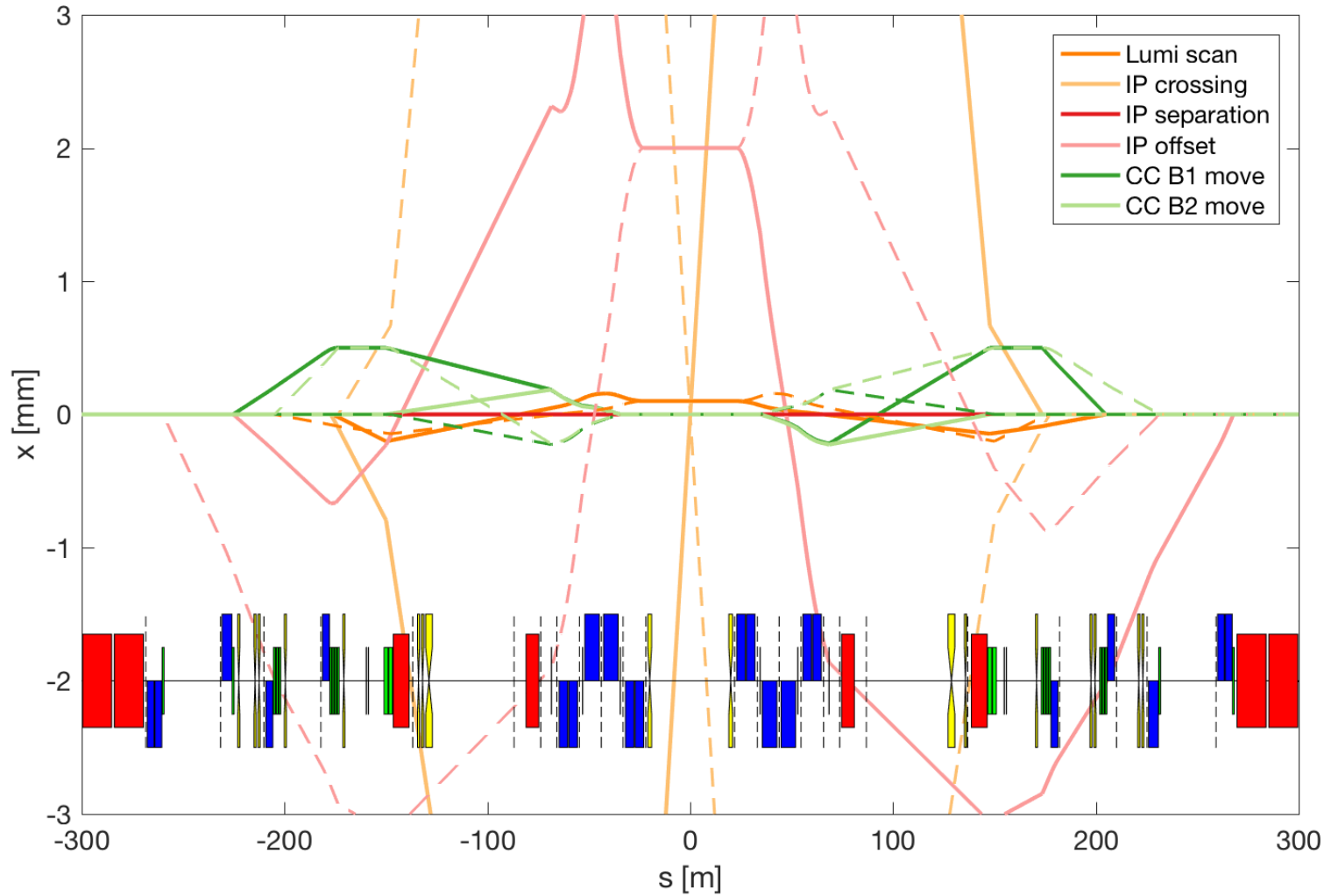

Knobs 1B (V orbit)

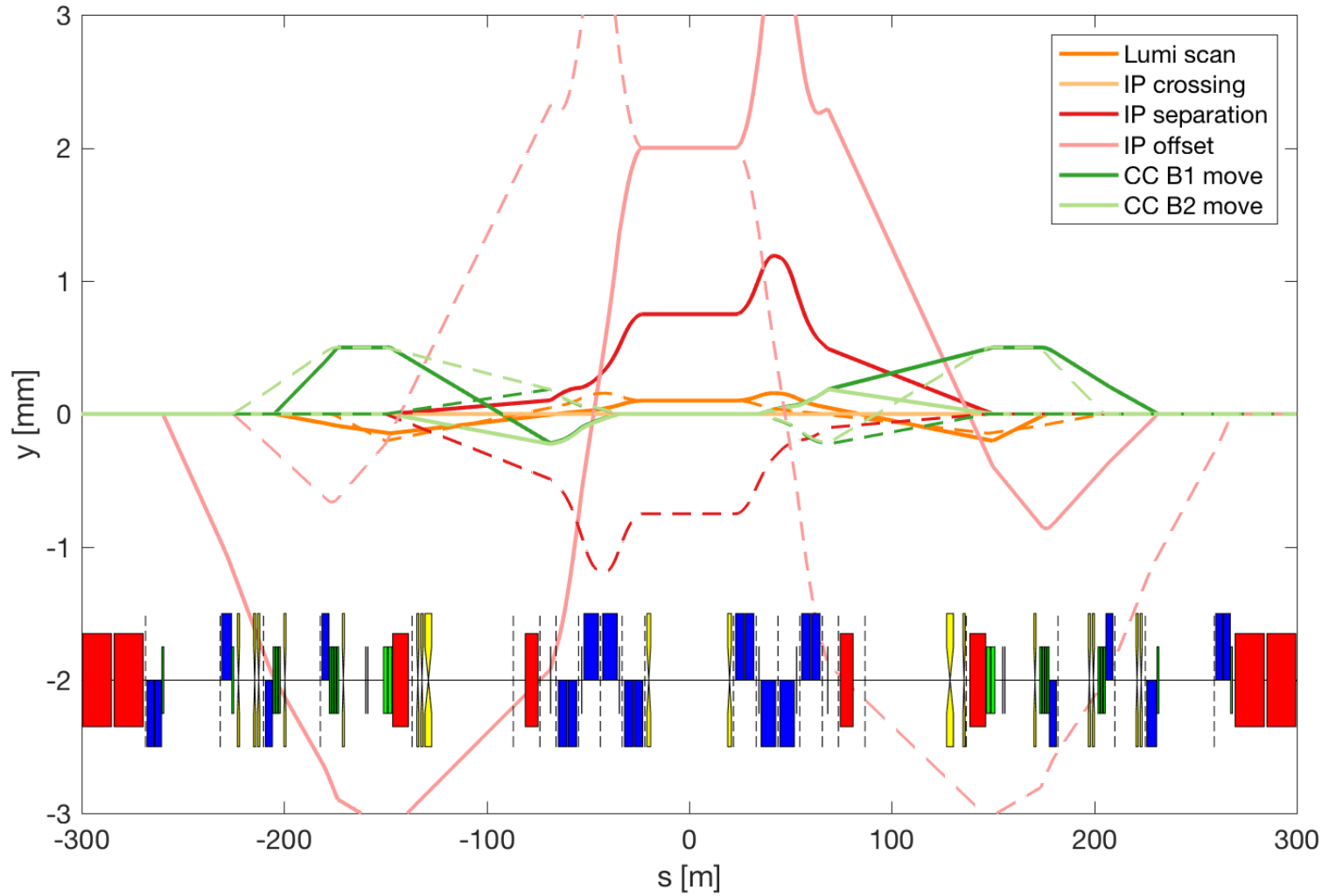

Option 1b
Like 1 with reduce crab knobs

Orbit Option 1b corrector budget

No W corr.

Right Point 5, H crossing, 2σ strength for errors

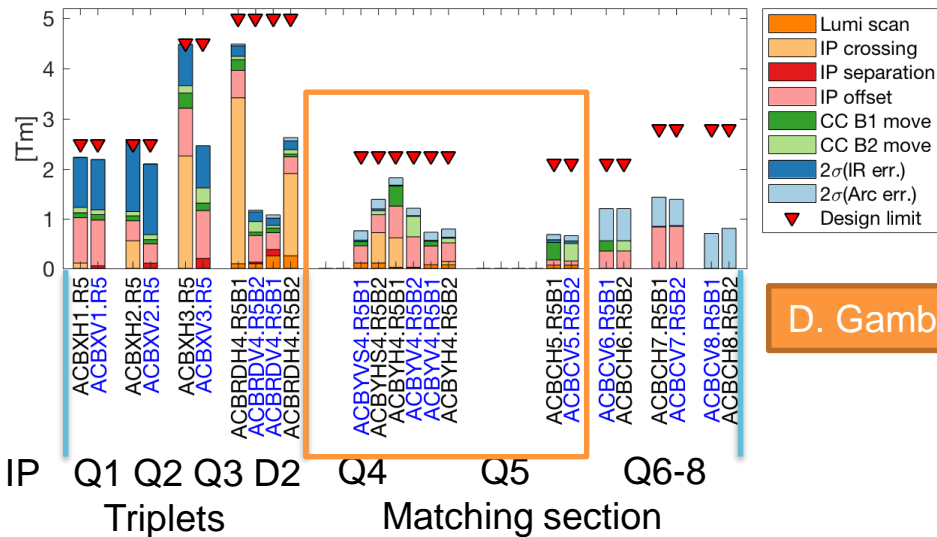

D. Gamba

For the Left and Point 1 symmetries applies:

- Left B1 -> Right B2,
- Left B2 -> Right B1
- H Point 5-> V Point 1

Knobs (Horizontal and Vertical):

- **IP crossing** ($\pm 250 \mu\text{rad}$), **separation** ($\pm 0.75 \text{ mm}$), **offset**: ($\pm 2.0 \text{ mm}$)
- **Luminosity** scan (individual beam IP shift of $\pm 100 \mu\text{m}$)
- **Limited** beam alignment in the crab cavities: 2 cavities (orbit adjust ± 0.5 different beam both planes) (**knob up to Q6**)

Machine errors (**uniformly distributed, uncorrelated**):

- **0.58 mm max** transverse displacement of quadrupoles at the IT (**IR. err.**)
- **0.6 mm max** transverse displacement of quadrupoles in the arc (**Arc. err.**).
- **10 mm max** longitudinal displacement, **0.5 mrad max** roll, **0.2% max** field error for D1 and D2 (**IR err.**) and in the arcs (**Arc err.**).

Residual orbit (0.6 mm DX/DY...)

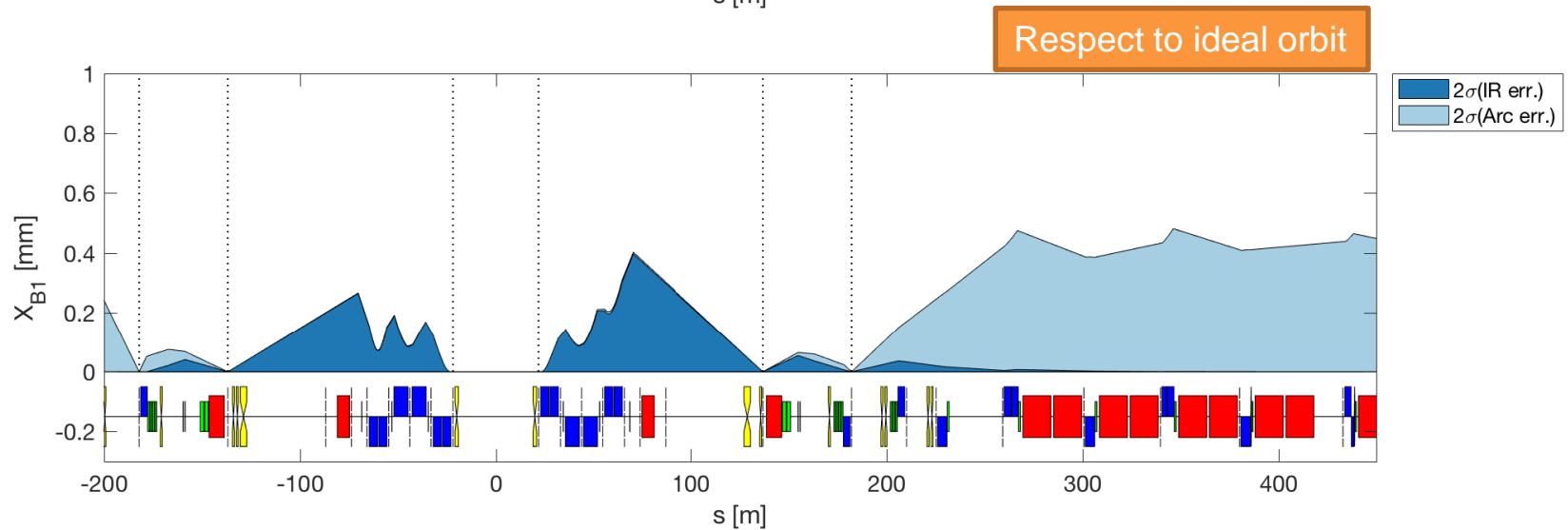
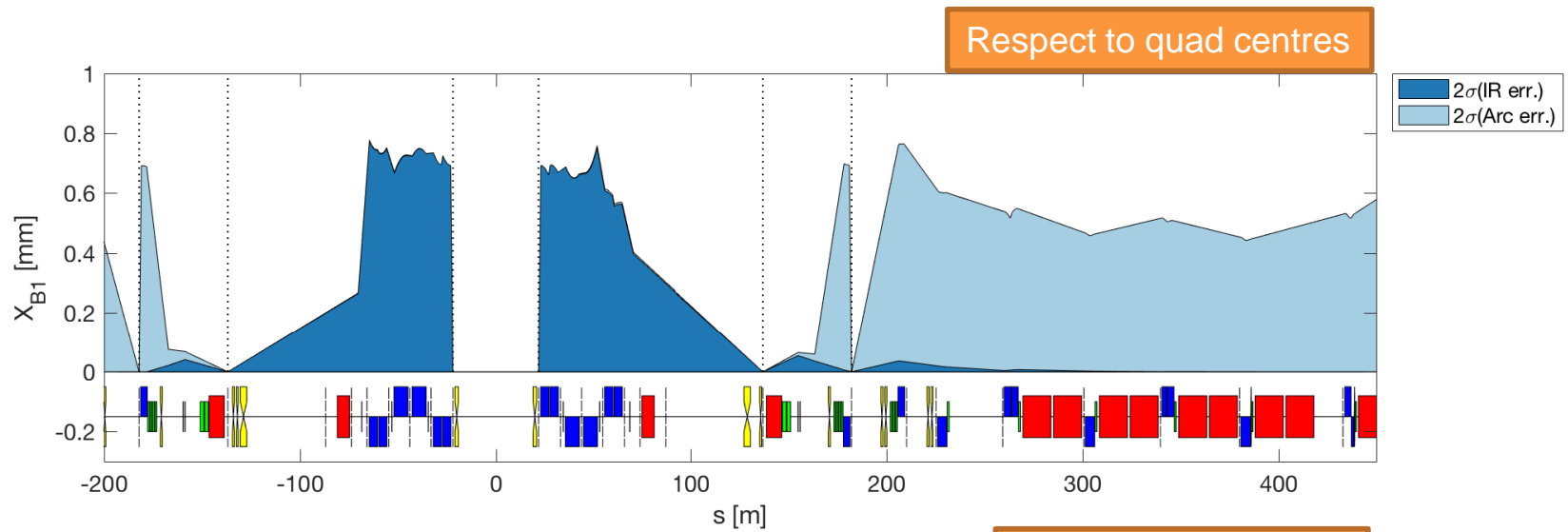

Residual orbit (respect to ideal orbit) [mm]

Element	IR err. [2*std]	Arc err. [2*std]	Lumi scan. [±0.1 mm]	Cros. [±250 μrad]	Sep. [±0.75 mm]	IP Off. [±2 mm]	CC B1 adjust [±0.5 mm]	CC B2 adjust [±0.5 mm]
TAXS X Y [mm]	0	0	0.1	4.99	0.75	2	0	0
MQXFA.[AB]1 X Y [mm]	0.12	0	0.12	9.34	0.91	2.43	0	0
MQXFB.[AB]2 X Y [mm]	0.21	0.01	0.16	14.2	1.19	3.47	0.1	0.1
MQXFA.[AB]3 X Y [mm]	0.3	0.01	0.1	14.31	0.8	2.67	0.21	0.21
MBXF X Y [mm]	0.37	0.01	0.03	12.85	0.45	2.11	0.23	0.23
TAXN X Y [mm]	0.05	0	0.14	3.85	0.13	2.85	0.42	0.42
MBRD X Y [mm]	0.06	0	0.19	2.06	0.06	3.12	0.48	0.48
MCBRD X Y [mm]	0.07	0	0.2	1.02	0.01	3.15	0.5	0.5
MCBY[HV].[AB]?4 X Y [mm]	0.01	0.08	0.09	0.1	0	2.93	0.5	0.5
MQY.4 X Y [mm]	0.01	0.05	0.08	0	0	2.75	0.48	0.48
TCLMB.5 X Y [mm]	0.03	0.24	0.02	0	0	2.14	0.28	0.28
MCBY[HV].[AB]?5 X Y [mm]	0.04	0.31	0.01	0	0	2.08	0.25	0.25
MQY.5 X Y [mm]	0.04	0.36	0	0	0	1.98	0.22	0.22
TCLMC.6 X Y [mm]	0.02	0.54	0	0	0	1.35	0.07	0.07
MCBC[HV].6 X Y [mm]	0.02	0.59	0	0	0	1.18	0	0
MQML.6 X Y [mm]	0.02	0.57	0	0	0	1.22	0.04	0.04
MCBC[HV].7 X Y [mm]	0.01	0.48	0	0	0	0	0	0
MQM.[AB]7 X Y [mm]	0.01	0.47	0	0	0	0.25	0	0
MCBC[HV].8 X Y [mm]	0	0.62	0	0	0	0	0	0
MQML.8 X Y [mm]	0	0.6	0	0	0	0	0	0
MCBC[HV].9 X Y [mm]	0	0.49	0	0	0	0	0	0
MQMC.9 X Y [mm]	0	0.45	0	0	0	0	0	0
MQM.9 X Y [mm]	0	0.48	0	0	0	0	0	0
MCB[HV].10 X Y [mm]	0	0.63	0	0	0	0	0	0
MQML.10 X Y [mm]	0	0.61	0	0	0	0	0	0

Residual orbit (respect to quad center) [mm]

Element	IR err. [2*std]	Arc err. [2*std]	Lumi scan. [±0.1 mm]	Cros. [±250 μrad]	Sep. [±0.75 mm]	IP Off. [±2 mm]	CC B1 adjust [±0.5 mm]	CC B2 adjust [±0.5 mm]
TAXS X Y [mm]	0	0	0.1	4.99	0.75	2	0	0
MQXFA.[AB]1 X Y [mm]	0.74	0	0.12	9.34	0.91	2.43	0	0
MQXFB.[AB]2 X Y [mm]	0.75	0.01	0.16	14.2	1.19	3.47	0.1	0.1
MQXFA.[AB]3 X Y [mm]	0.78	0.01	0.1	14.31	0.8	2.67	0.21	0.21
MBXF X Y [mm]	0.37	0.01	0.03	12.85	0.45	2.11	0.23	0.23
TAXN X Y [mm]	0.05	0	0.14	3.85	0.13	2.85	0.42	0.42
MBRD X Y [mm]	0.06	0	0.19	2.06	0.06	3.12	0.48	0.48
MCBRD X Y [mm]	0.07	0	0.2	1.02	0.01	3.15	0.5	0.5
MCBY[HV].[AB]?4 X Y [mm]	0.01	0.08	0.09	0.1	0	2.93	0.5	0.5
MQY.4 X Y [mm]	0.01	0.69	0.08	0	0	2.75	0.48	0.48
TCLMB.5 X Y [mm]	0.03	0.24	0.02	0	0	2.14	0.28	0.28
MCBY[HV].[AB]?5 X Y [mm]	0.04	0.31	0.01	0	0	2.08	0.25	0.25
MQY.5 X Y [mm]	0.04	0.73	0	0	0	1.98	0.22	0.22
TCLMC.6 X Y [mm]	0.02	0.54	0	0	0	1.35	0.07	0.07
MCBC[HV].6 X Y [mm]	0.02	0.59	0	0	0	1.18	0	0
MQML.6 X Y [mm]	0.02	0.63	0	0	0	1.22	0.04	0.04
MCBC[HV].7 X Y [mm]	0.01	0.48	0	0	0	0	0	0
MQM.[AB]7 X Y [mm]	0.01	0.56	0	0	0	0.25	0	0
MCBC[HV].8 X Y [mm]	0	0.62	0	0	0	0	0	0
MQML.8 X Y [mm]	0	0.46	0	0	0	0	0	0
MCBC[HV].9 X Y [mm]	0	0.49	0	0	0	0	0	0
MQMC.9 X Y [mm]	0	0.6	0	0	0	0	0	0
MQM.9 X Y [mm]	0	0.56	0	0	0	0	0	0
MCB[HV].10 X Y [mm]	0	0.63	0	0	0	0	0	0
MQML.10 X Y [mm]	0	0.45	0	0	0	0	0	0

Knobs (H orbit)

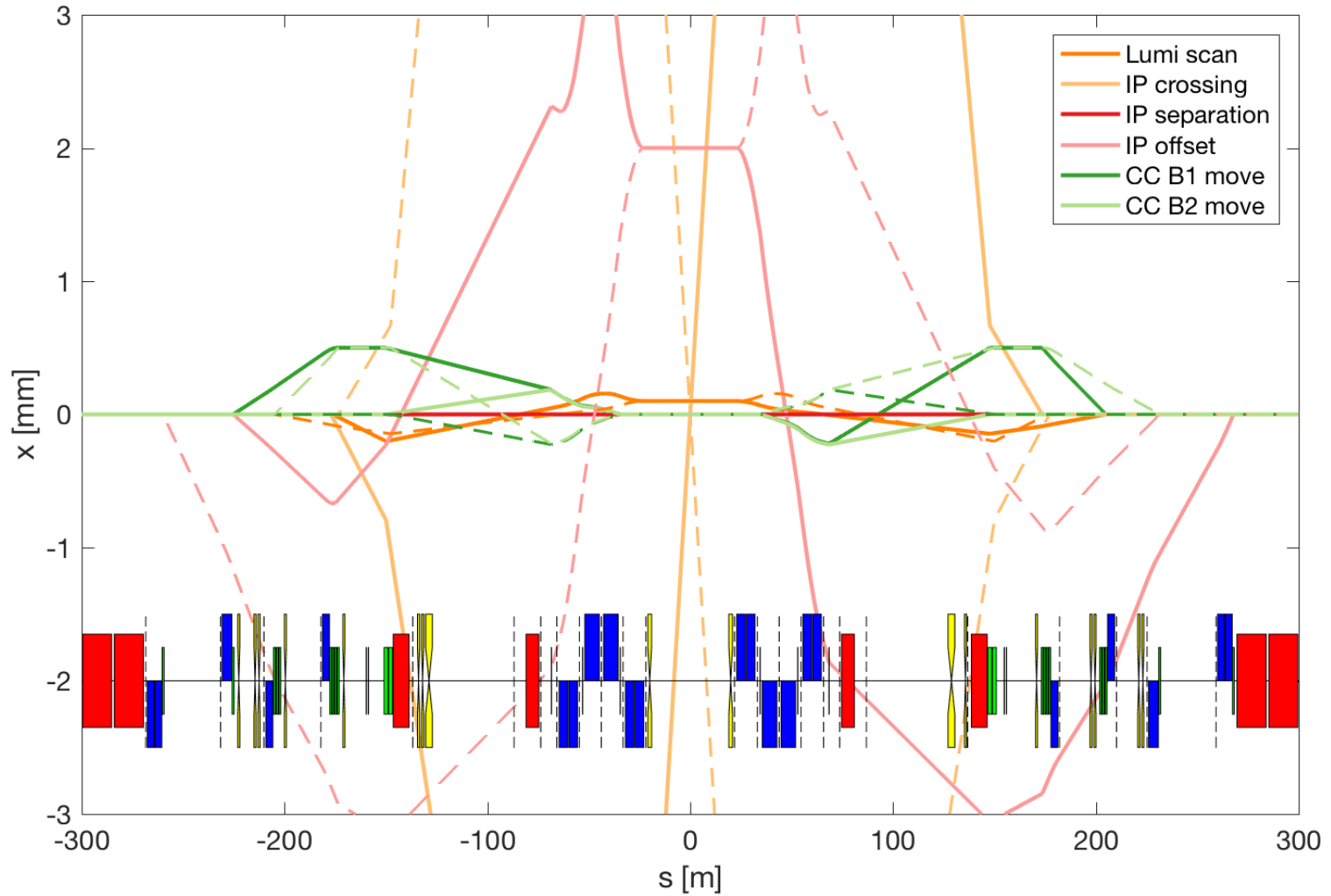

Knobs (V orbit)

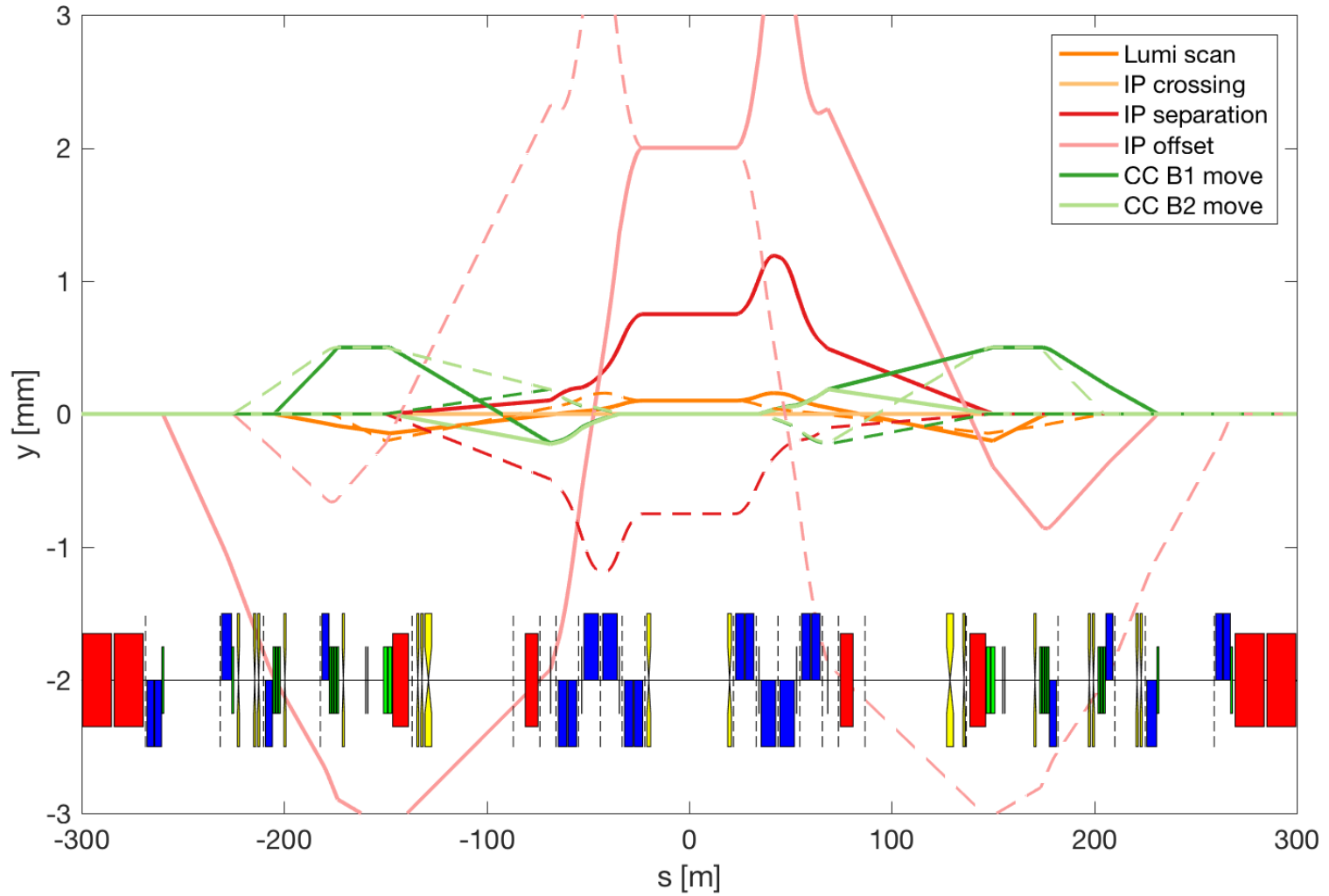

Option 2a (offset knob does not use Q4)

Orbit Option 2a corrector budget

Right Point 5, H crossing, 2σ strength for errors

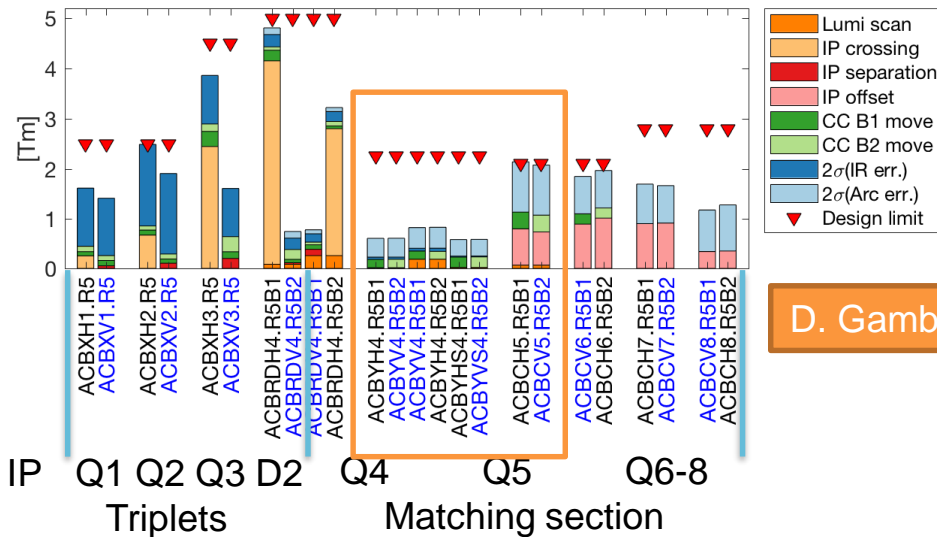

D. Gamba

For the Left and Point 1 symmetries applies:

- Left B1 -> Right B2,
- Left B2 -> Right B1
- H Point 5-> V Point 1

Knobs (Horizontal and Vertical):

- **IP crossing** ($\pm 250 \mu\text{rad}$), **separation** ($\pm 0.75 \text{ mm}$), **offset** ($\pm 2.0 \text{ mm}$) using remote alignment capabilities.
- **Luminosity** scan (individual beam IP shift of $\pm 100 \mu\text{m}$)
- **Limited** beam alignment in the crab cavities: 2 cavities (orbit adjust ± 0.5 different beam both planes) (**knob up to Q6**)

Machine errors (**uniformly distributed, uncorrelated**):

- **0.7 mm max** transverse displacement of quadrupoles at the IT (**IR. err.**)
- **0.7 mm max** transverse displacement of quadrupoles in the arc (**Arc. err.**).
- **10 mm max** longitudinal displacement, **0.5 mrad max** roll, **0.2% max** field error for D1 and D2 (**IR err.**) and in the arcs (**Arc err.**).

Residual orbit 2a (0.7 mm DX/DY...)

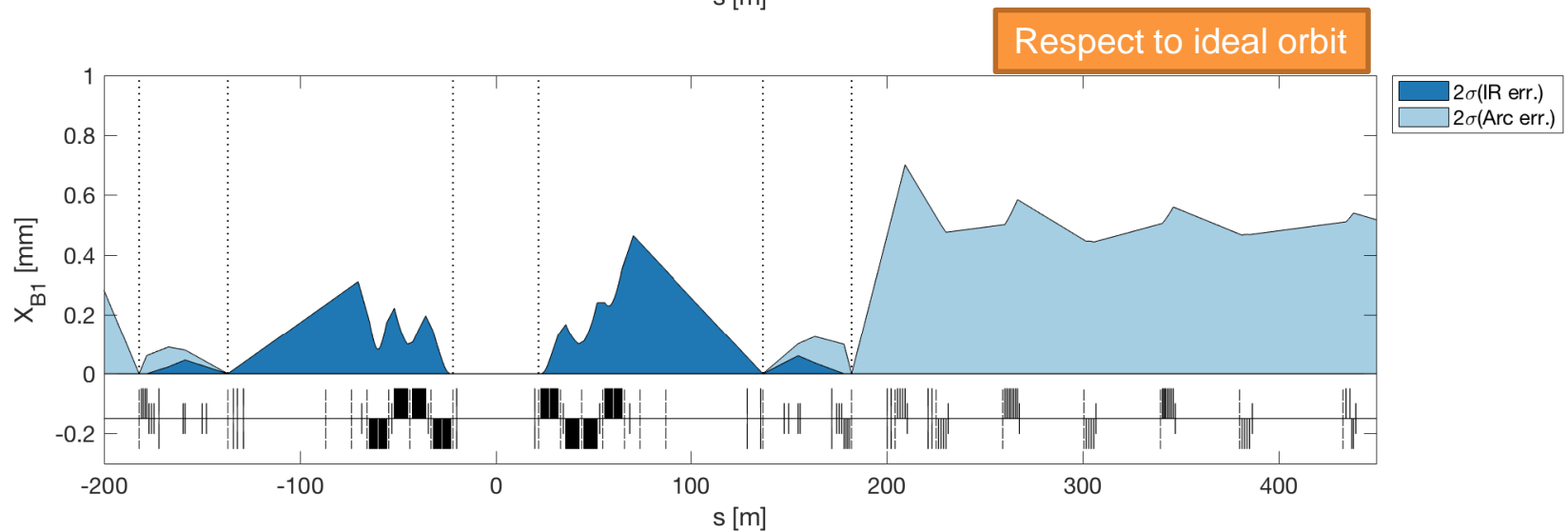
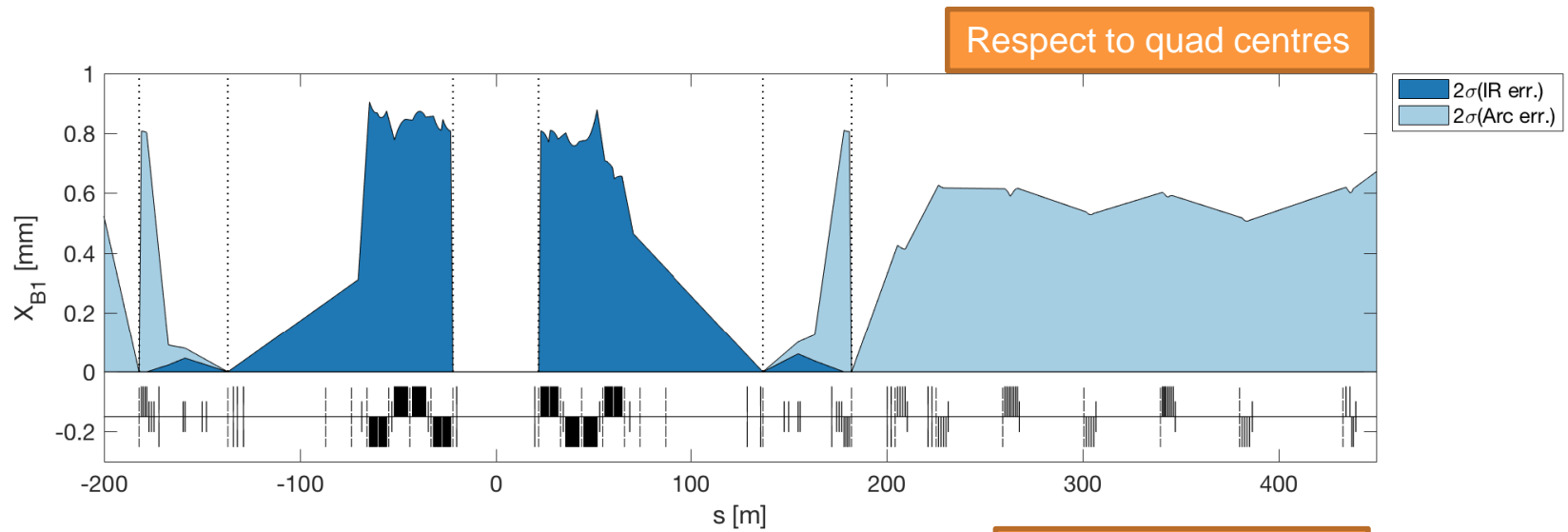

Residual orbit 2 (respect to ideal orbit) [mm]

Element	IR err. [2*std]	Arc err. [2*std]	Lumi scan. [±0.1 mm]	Cros. [±250 μrad]	Sep. [±0.75 mm]	IP Off. [±2 mm] ***	CC B1 adjust [±0.5 mm]	CC B2 adjust [±0.5 mm]
TAXS X Y [mm]	0	0	0.1	4.99	0.75	2	0	0
MQXFA.[AB]1 X Y [mm]	0.14	0	0.12	9.34	0.91	2	0	0
MQXFB.[AB]2 X Y [mm]	0.24	0	0.16	14.14	1.19	2	0.1	0.1
MQXFA.[AB]3 X Y [mm]	0.35	0	0.1	14.12	0.8	2	0.21	0.21
MBXF X Y [mm]	0.43	0	0.03	12.63	0.45	2	0.23	0.23
TAXN X Y [mm]	0.06	0	0.14	3.3	0.13	2	0.42	0.42
MBRD X Y [mm]	0.07	0	0.19	1.45	0.06	2	0.48	0.48
MCBRD X Y [mm]	0.08	0.02	0.2	0.25	0.01	2	0.5	0.5
MCBY[HV].[AB]?4 X Y [mm]	0.01	0.2	0.1	0	0	2	0.5	0.5
MQY.4 X Y [mm]	0	0.13	0.09	0	0	2	0.48	0.48
TCLMC.5 X Y [mm]	0	0.65	0.02	0	0	2	0.25	0.25
MCBC[HV].5 X Y [mm]	0	0.74	0	0	0	2.04	0.21	0.21
MQML.5 X Y [mm]	0	0.73	0.01	0	0	2.02	0.22	0.22
TCLMC.6 X Y [mm]	0	0.63	0	0	0	2.19	0.07	0.07
MCBC[HV].6 X Y [mm]	0	0.68	0	0	0	2.23	0	0
MQML.6 X Y [mm]	0	0.67	0	0	0	2.24	0.04	0.04
MCBC[HV].7 X Y [mm]	0	0.6	0	0	0	0.68	0	0
MQM.[AB]7 X Y [mm]	0	0.59	0	0	0	0.76	0	0
MCBC[HV].8 X Y [mm]	0	0.72	0	0	0	0	0	0
MQML.8 X Y [mm]	0	0.7	0	0	0	0.07	0	0
MCBC[HV].9 X Y [mm]	0	0.57	0	0	0	0	0	0
MQMC.9 X Y [mm]	0	0.52	0	0	0	0	0	0
MQM.9 X Y [mm]	0	0.56	0	0	0	0	0	0
MCB[HV].10 X Y [mm]	0	0.74	0	0	0	0	0	0
MQML.10 X Y [mm]	0	0.71	0	0	0	0	0	0

*** It requires to translate Q1-Q4 of 2 mm in the direction of the required offset.

Residual orbit 2 (respect to quad center) [mm]

Element	IR err. [2*std]	Arc err. [2*std]	Lumi scan. [±0.1 mm]	Cros. [±250 μrad]	Sep. [±0.75 mm]	IP Off. [±2 mm] ***	CC B1 adjust [±0.5 mm]	CC B2 adjust [±0.5 mm]
TAXS X Y [mm]	0	0	0.1	4.99	0.75	2	0	0
MQXFA.[AB]1 X Y [mm]	0.86	0	0.12	9.34	0.91	0	0	0
MQXFB.[AB]2 X Y [mm]	0.88	0	0.16	14.14	1.19	0	0.1	0.1
MQXFA.[AB]3 X Y [mm]	0.91	0	0.1	14.12	0.8	0	0.21	0.21
MBXF X Y [mm]	0.43	0	0.03	12.63	0.45	0	0.23	0.23
TAXN X Y [mm]	0.06	0	0.14	3.3	0.13	0	0.42	0.42
MBRD X Y [mm]	0.07	0	0.19	1.45	0.06	0	0.48	0.48
MCBRD X Y [mm]	0.08	0.02	0.2	0.25	0.01	0	0.5	0.5
MCBY[HV].[AB]?4 X Y [mm]	0.01	0.2	0.1	0	0	0	0.5	0.5
MQY.4 X Y [mm]	0	0.81	0.09	0	0	0	0.48	0.48
TCLMC.5 X Y [mm]	0	0.65	0.02	0	0	2	0.25	0.25
MCBC[HV].5 X Y [mm]	0	0.74	0	0	0	2.04	0.21	0.21
MQML.5 X Y [mm]	0	0.69	0.01	0	0	2.02	0.22	0.22
TCLMC.6 X Y [mm]	0	0.63	0	0	0	2.19	0.07	0.07
MCBC[HV].6 X Y [mm]	0	0.68	0	0	0	2.23	0	0
MQML.6 X Y [mm]	0	0.66	0	0	0	2.24	0.04	0.04
MCBC[HV].7 X Y [mm]	0	0.6	0	0	0	0.68	0	0
MQM.[AB]7 X Y [mm]	0	0.65	0	0	0	0.76	0	0
MCBC[HV].8 X Y [mm]	0	0.72	0	0	0	0	0	0
MQML.8 X Y [mm]	0	0.54	0	0	0	0.07	0	0
MCBC[HV].9 X Y [mm]	0	0.57	0	0	0	0	0	0
MQMC.9 X Y [mm]	0	0.7	0	0	0	0	0	0
MQM.9 X Y [mm]	0	0.65	0	0	0	0	0	0
MCB[HV].10 X Y [mm]	0	0.74	0	0	0	0	0	0
MQML.10 X Y [mm]	0	0.52	0	0	0	0	0	0

*** It requires to translate Q1-Q4 of 2 mm in the direction of the required offset.

Knobs 2 (H orbit)

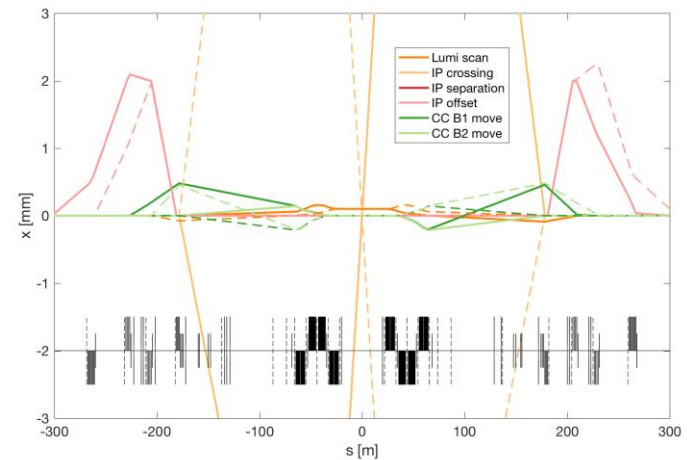
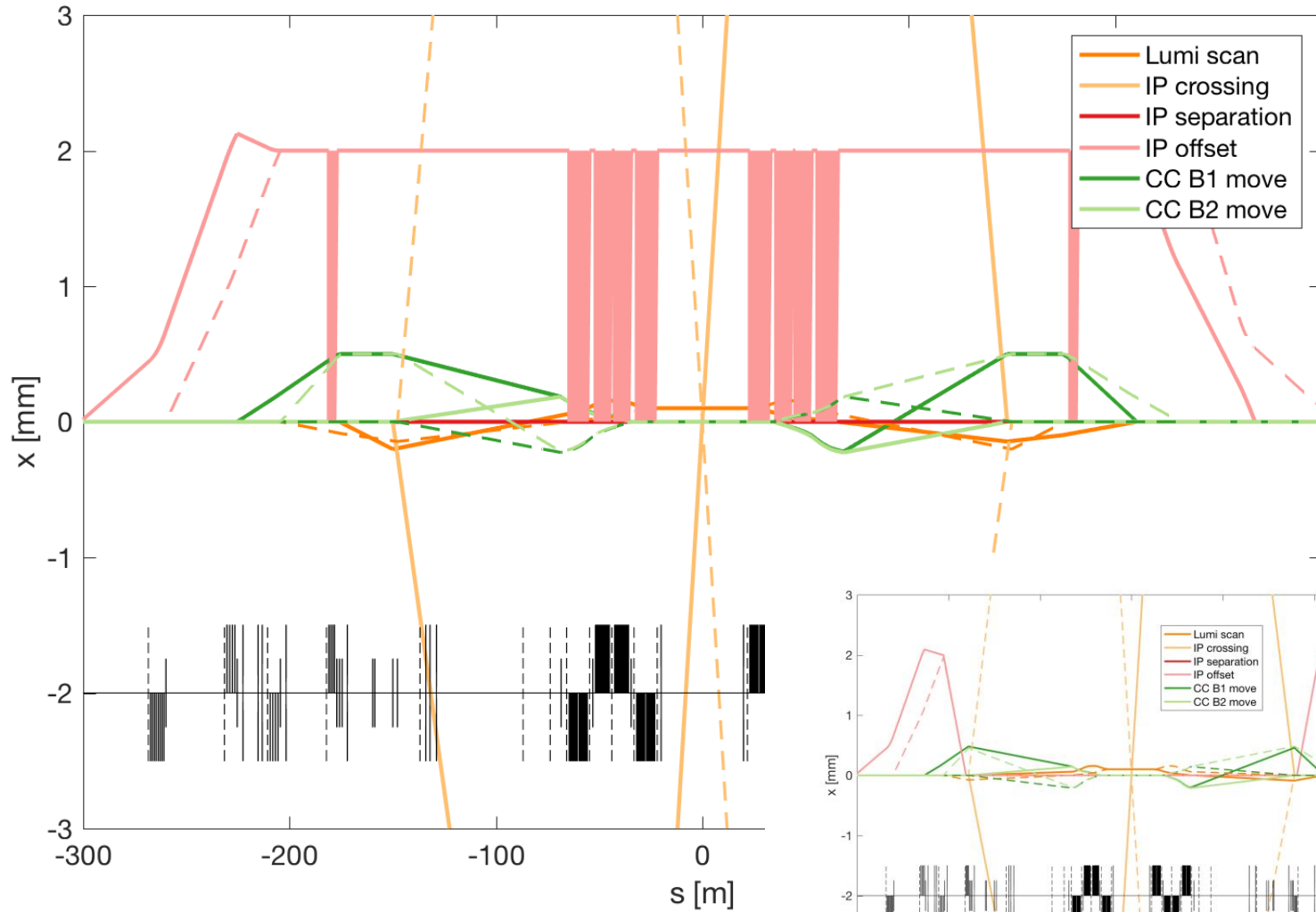

Knobs 2 (V orbit)

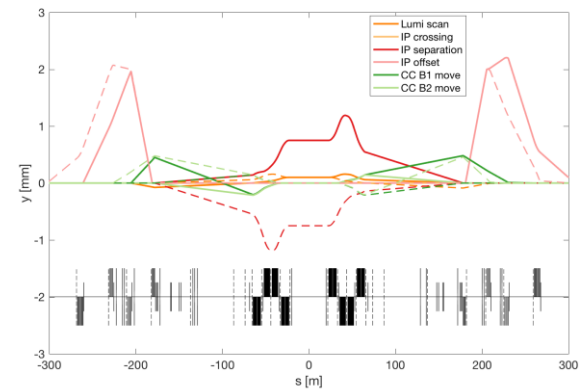
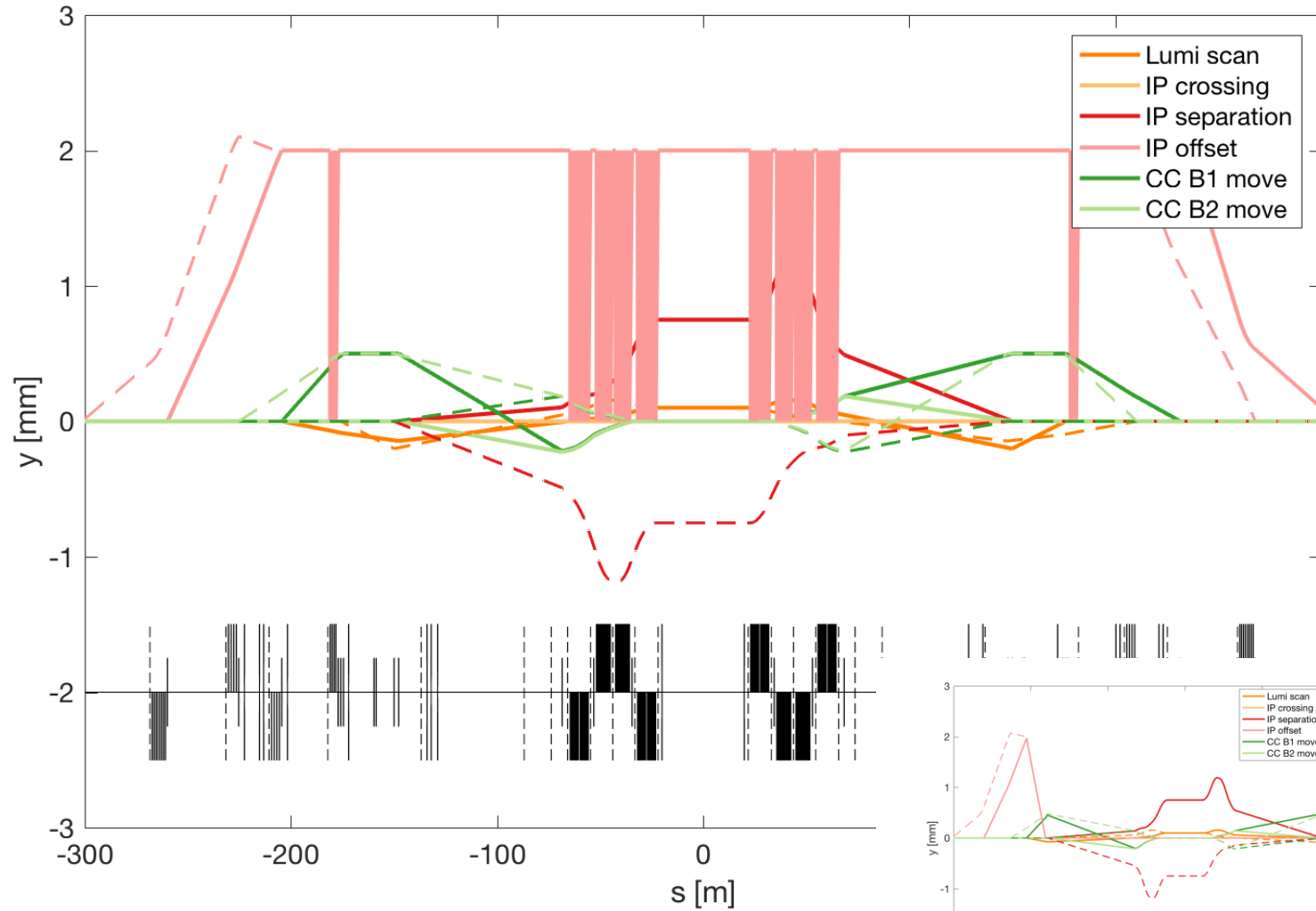

Offset knob -- 2

Respect to quad centre

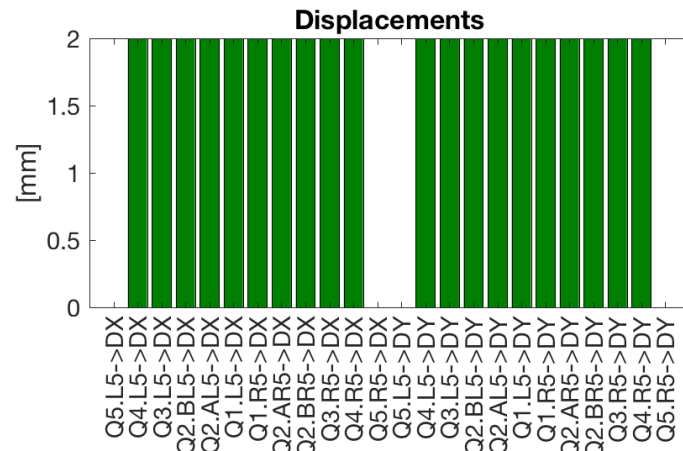
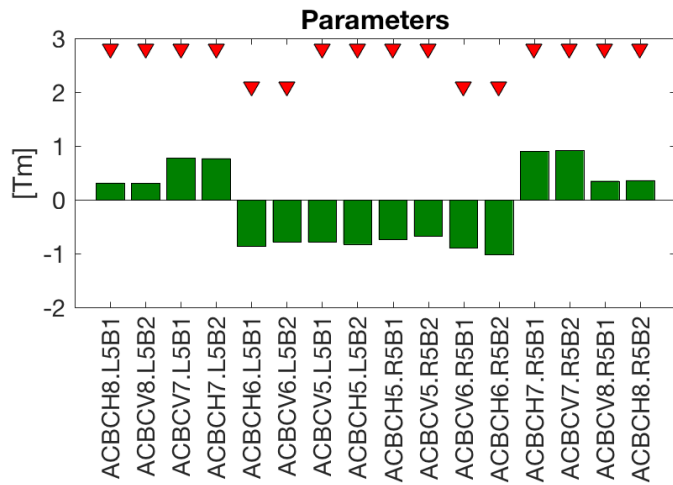
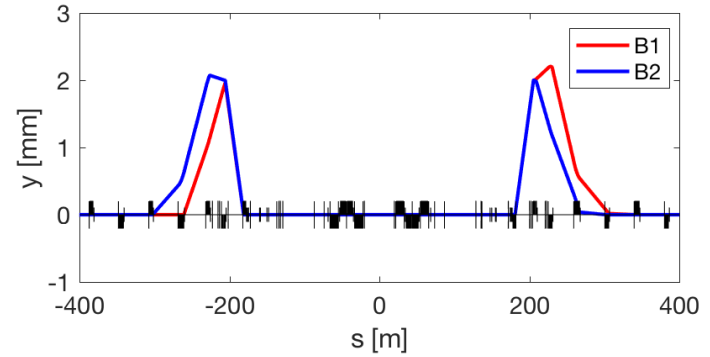
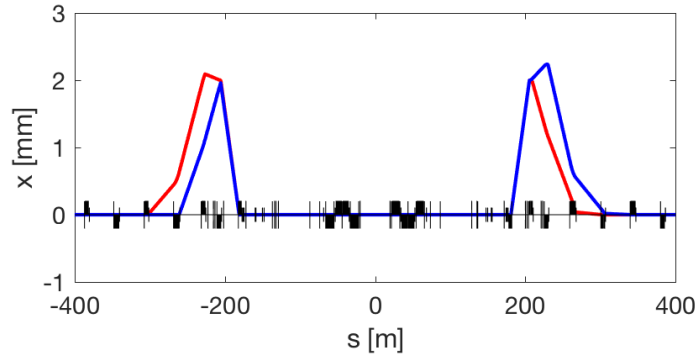

Option 2b (proposed one)

Offset knob – 2b

Respect to quad centre

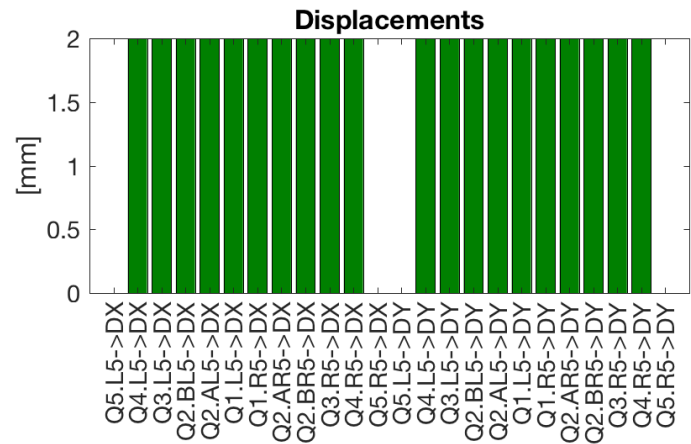
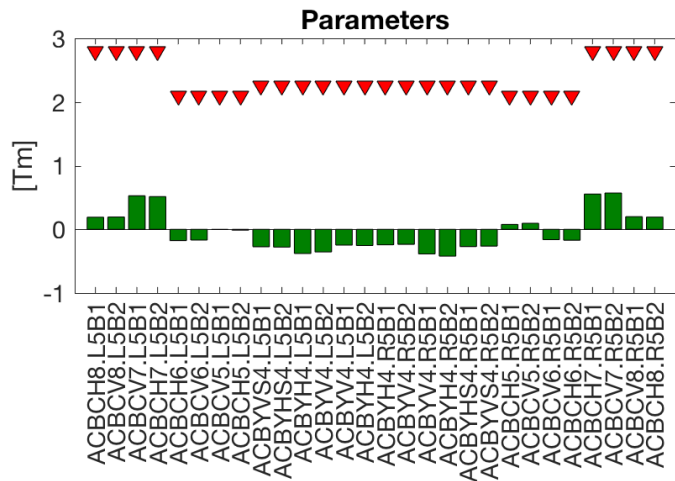
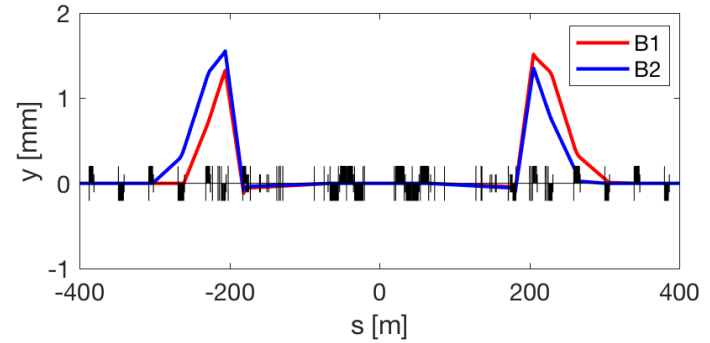
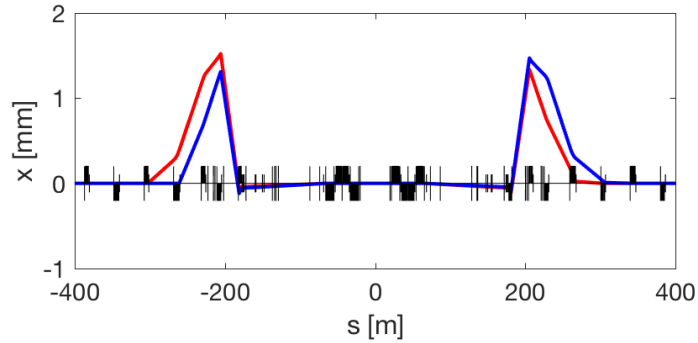

Orbit Option 2b corrector budget

Right Point 5, H crossing, 2σ strength for errors

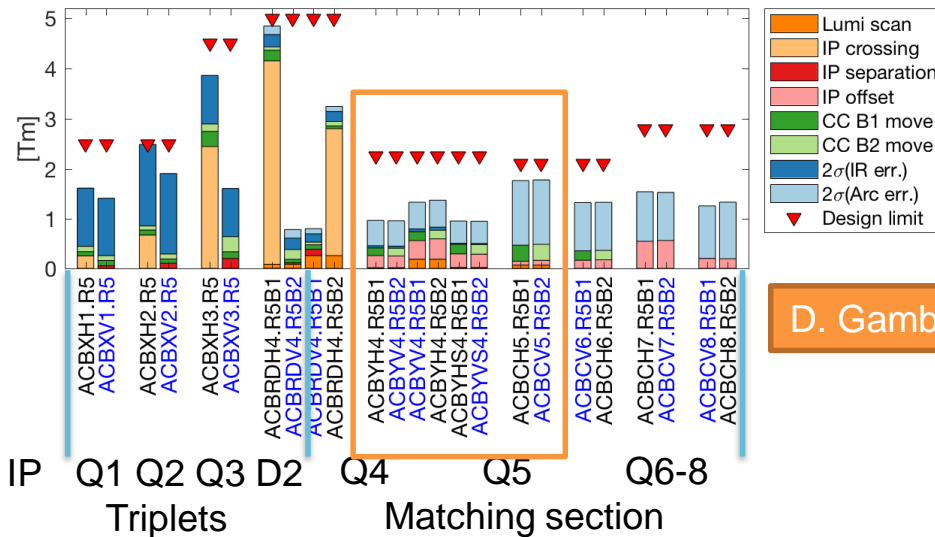

D. Gamba

For the Left and Point 1 symmetries applies:

- Left B1 -> Right B2,
- Left B2 -> Right B1
- H Point 5-> V Point 1

Knobs (Horizontal and Vertical):

- **IP crossing** ($\pm 250 \mu\text{rad}$), **separation** ($\pm 0.75 \text{ mm}$), **offset** ($\pm 2.0 \text{ mm}$) using remote alignment capabilities.
- **Luminosity** scan (individual beam IP shift of $\pm 100 \mu\text{m}$)
- **Limited** beam alignment in the crab cavities: 2 cavities (orbit adjust ± 0.5 different beam both planes) (**knob up to Q6**)

Machine errors (**uniformly distributed, uncorrelated**):

- **0.7 mm max** transverse displacement of quadrupoles at the IT (**IR. err.**)
- **0.9 mm max** transverse displacement of quadrupoles in the arc (**Arc. err.**).
- **10 mm max** longitudinal displacement, **0.5 mrad max** roll, **0.2% max** field error for D1 and D2 (**IR err.**) and in the arcs (**Arc err.**).

Residual orbit 2b (0.7, 0.9 mm DX/DY...)

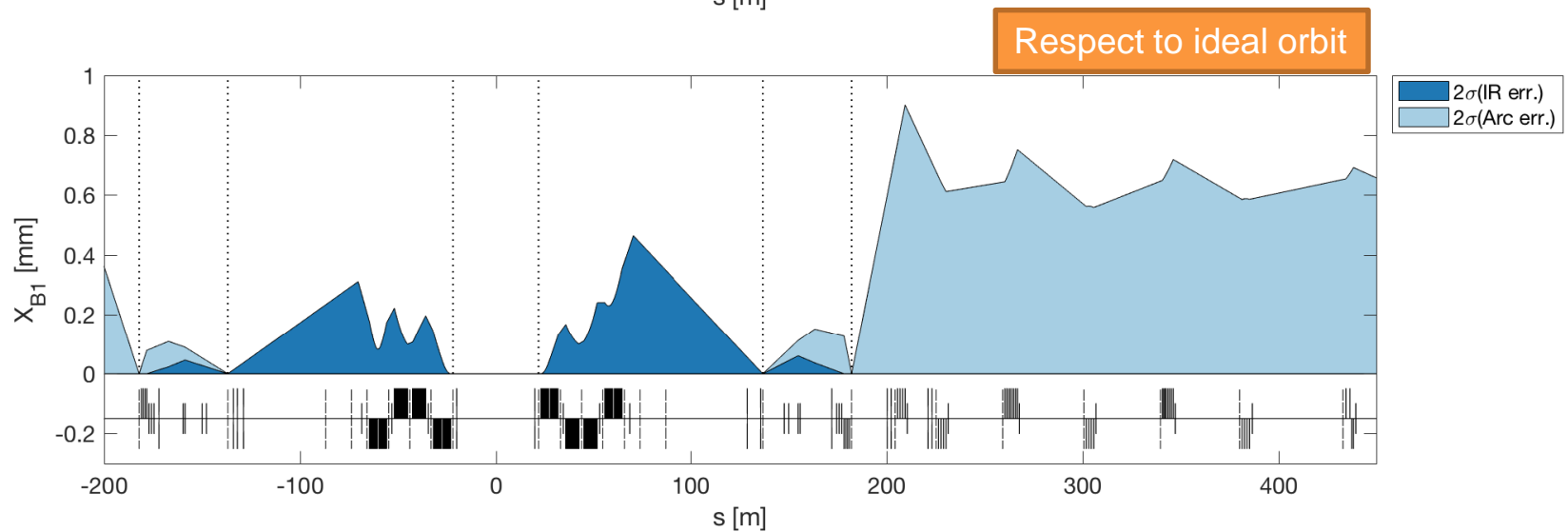
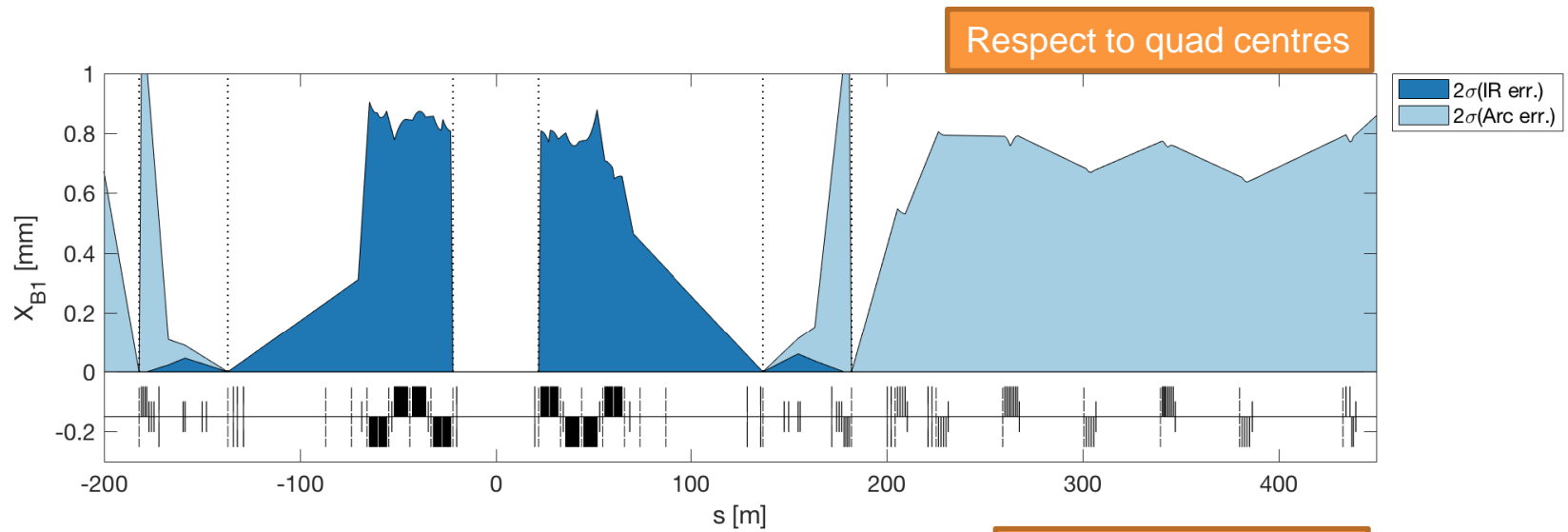

Residual orbit 2b (respect to ideal orbit) [mm]

Element	IR err. [2*std]	Arc err. [2*std]	Lumi scan. [±0.1 mm]	Cros. [±250 μrad]	Sep. [±0.75 mm]	IP Off. [±2 mm] ***	CC B1 adjust [±0.5 mm]	CC B2 adjust [±0.5 mm]
TAXS X Y [mm]	0	0	0.1	4.99	0.75	2	0	0
MQXFA.[AB]1 X Y [mm]	0.14	0	0.12	9.34	0.91	2	0	0
MQXFB.[AB]2 X Y [mm]	0.24	0	0.16	14.14	1.19	2	0.1	0.1
MQXFA.[AB]3 X Y [mm]	0.35	0	0.1	14.12	0.8	2	0.21	0.21
MBXF X Y [mm]	0.43	0	0.03	12.63	0.45	2	0.23	0.23
TAXN X Y [mm]	0.06	0	0.14	3.3	0.13	2	0.42	0.42
MBRD X Y [mm]	0.07	0	0.19	1.45	0.06	2	0.48	0.48
MCBRD X Y [mm]	0.08	0.02	0.2	0.25	0.01	2	0.5	0.5
MCBY[HV].[AB]?4 X Y [mm]	0.01	0.25	0.1	0	0	2	0.5	0.5
MQY.4 X Y [mm]	0	0.17	0.09	0	0	0.12	0.48	0.48
TCLMC.5 X Y [mm]	0	0.84	0.02	0	0	1.61	0.25	0.25
MCBC[HV].5 X Y [mm]	0	0.95	0	0	0	1.57	0.21	0.21
MQML.5 X Y [mm]	0	0.93	0.01	0	0	1.55	0.22	0.22
TCLMC.6 X Y [mm]	0	0.82	0	0	0	1.37	0.07	0.07
MCBC[HV].6 X Y [mm]	0	0.88	0	0	0	1.34	0	0
MQML.6 X Y [mm]	0	0.86	0	0	0	1.32	0.04	0.04
MCBC[HV].7 X Y [mm]	0	0.77	0	0	0	0.42	0	0
MQM.[AB]7 X Y [mm]	0	0.75	0	0	0	0.42	0	0
MCBC[HV].8 X Y [mm]	0	0.93	0	0	0	0	0	0
MQML.8 X Y [mm]	0	0.9	0	0	0	0.04	0	0
MCBC[HV].9 X Y [mm]	0	0.73	0	0	0	0	0	0
MQMC.9 X Y [mm]	0	0.67	0	0	0	0	0	0
MQM.9 X Y [mm]	0	0.72	0	0	0	0	0	0
MCB[HV].10 X Y [mm]	0	0.94	0	0	0	0	0	0
MQML.10 X Y [mm]	0	0.91	0	0	0	0	0	0

*** It requires to translate Q1-Q4 of 2 mm in the direction of the required offset.

Residual orbit 2b (respect to quad center) [mm]

Element	IR err. [2*std]	Arc err. [2*std]	Lumi scan. [±0.1 mm]	Cros. [±250 μrad]	Sep. [±0.75 mm]	IP Off. [±2 mm] ***	CC B1 adjust [±0.5 mm]	CC B2 adjust [±0.5 mm]
TAXS X Y [mm]	0	0	0.1	4.99	0.75	2	0	0
MQXFA.[AB]1 X Y [mm]	0.86	0	0.12	9.34	0.91	0	0	0
MQXFB.[AB]2 X Y [mm]	0.88	0	0.16	14.14	1.19	0	0.1	0.1
MQXFA.[AB]3 X Y [mm]	0.91	0	0.1	14.12	0.8	0	0.21	0.21
MBXF X Y [mm]	0.43	0	0.03	12.63	0.45	0	0.23	0.23
TAXN X Y [mm]	0.06	0	0.14	3.3	0.13	0	0.42	0.42
MBRD X Y [mm]	0.07	0	0.19	1.45	0.06	0	0.48	0.48
MCBRD X Y [mm]	0.08	0.02	0.2	0.25	0.01	0	0.5	0.5
MCBY[HV].[AB]?4 X Y [mm]	0.01	0.25	0.1	0	0	0	0.5	0.5
MQY.4 X Y [mm]	0	1.04	0.09	0	0	0.12	0.48	0.48
TCLMC.5 X Y [mm]	0	0.84	0.02	0	0	1.61	0.25	0.25
MCBC[HV].5 X Y [mm]	0	0.95	0	0	0	1.57	0.21	0.21
MQML.5 X Y [mm]	0	0.89	0.01	0	0	1.55	0.22	0.22
TCLMC.6 X Y [mm]	0	0.82	0	0	0	1.37	0.07	0.07
MCBC[HV].6 X Y [mm]	0	0.88	0	0	0	1.34	0	0
MQML.6 X Y [mm]	0	0.85	0	0	0	1.32	0.04	0.04
MCBC[HV].7 X Y [mm]	0	0.77	0	0	0	0.42	0	0
MQM.[AB]7 X Y [mm]	0	0.84	0	0	0	0.42	0	0
MCBC[HV].8 X Y [mm]	0	0.93	0	0	0	0	0	0
MQML.8 X Y [mm]	0	0.68	0	0	0	0.04	0	0
MCBC[HV].9 X Y [mm]	0	0.73	0	0	0	0	0	0
MQMC.9 X Y [mm]	0	0.9	0	0	0	0	0	0
MQM.9 X Y [mm]	0	0.84	0	0	0	0	0	0
MCB[HV].10 X Y [mm]	0	0.94	0	0	0	0	0	0
MQML.10 X Y [mm]	0	0.65	0	0	0	0	0	0

*** It requires to translate Q1-Q4 of 2 mm in the direction of the required offset.

Option 2

(proposed one with short offset)

Offset knob (short) – 2c

Respect to quad centre

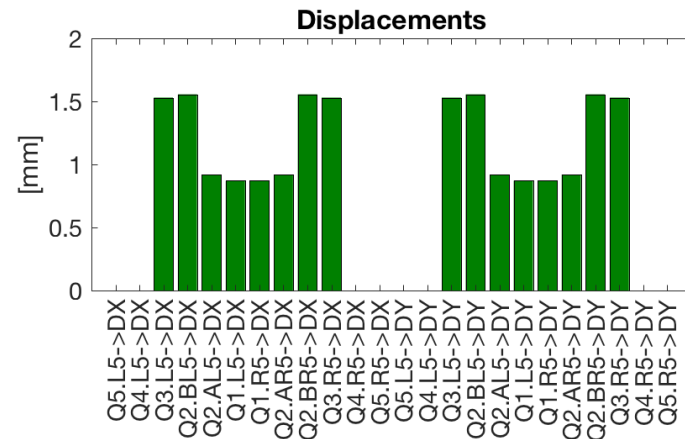
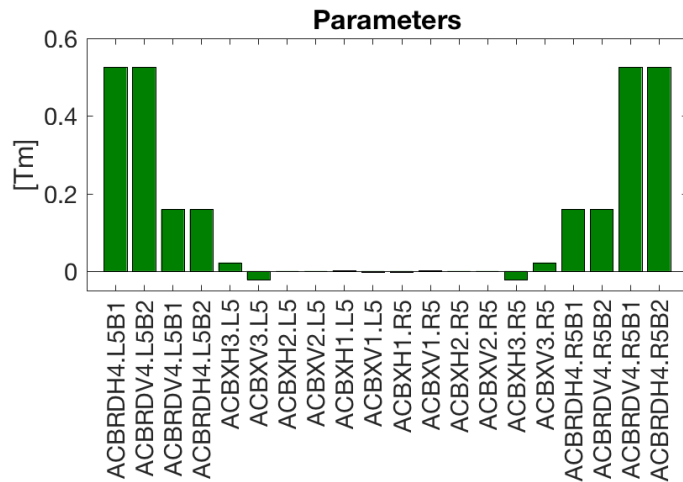
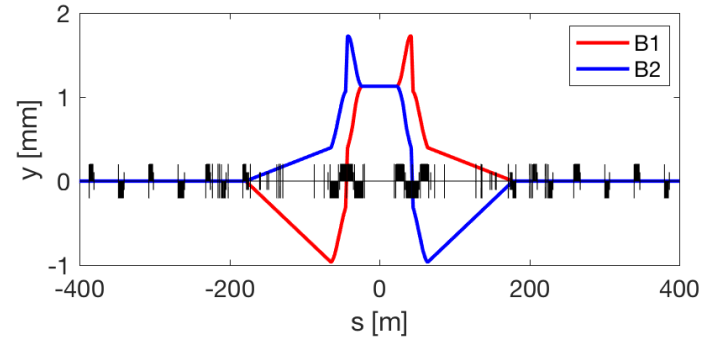
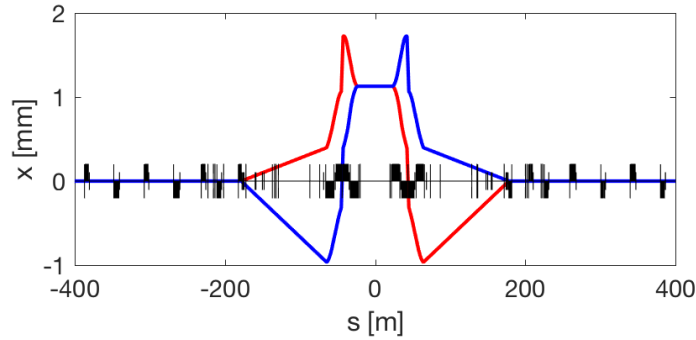

Orbit Option 2c corrector budget

Right Point 5, H crossing, 2σ strength for errors

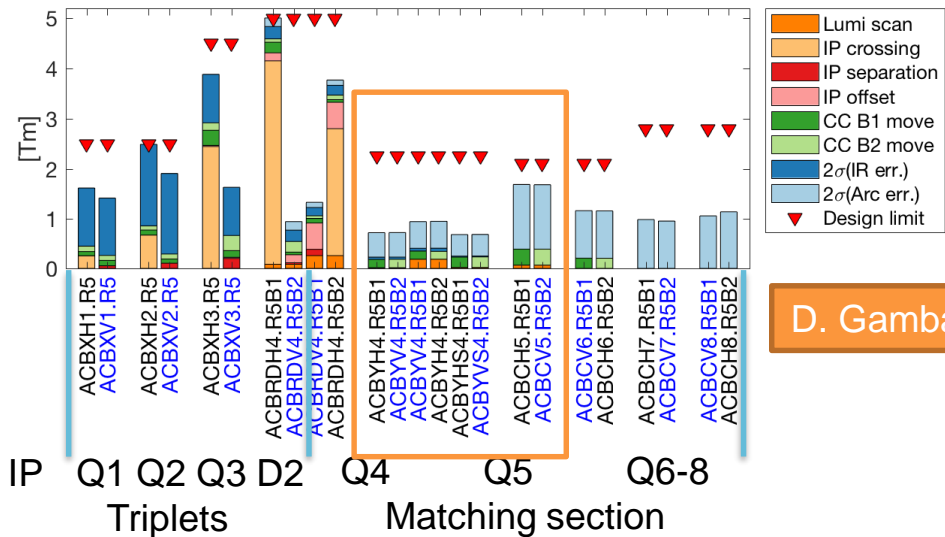

For the Left and Point 1 symmetries applies:

- Left B1 -> Right B2,
- Left B2 -> Right B1
- H Point 5-> V Point 1

Knobs (Horizontal and Vertical):

- **IP crossing** ($\pm 250 \mu\text{rad}$), **separation** ($\pm 0.75 \text{ mm}$), **offset** ($\pm 2.0 \text{ mm}$) using remote alignment capabilities.
- **Luminosity** scan (individual beam IP shift of $\pm 100 \mu\text{m}$)
- **Limited** beam alignment in the crab cavities: 2 cavities (orbit adjust ± 0.5 different beam both planes) (**knob up to Q6**)

Machine errors (**uniformly distributed, uncorrelated**):

- **0.7 mm max** transverse displacement of quadrupoles at the IT (**IR. err.**)
- **0.9 mm max** transverse displacement of quadrupoles in the arc (**Arc. err.**).
- **10 mm max** longitudinal displacement, **0.5 mrad max** roll, **0.2% max** field error for D1 and D2 (**IR err.**) and in the arcs (**Arc err.**).

Residual orbit 2c (0.7, 0.9 mm DX/DY...)

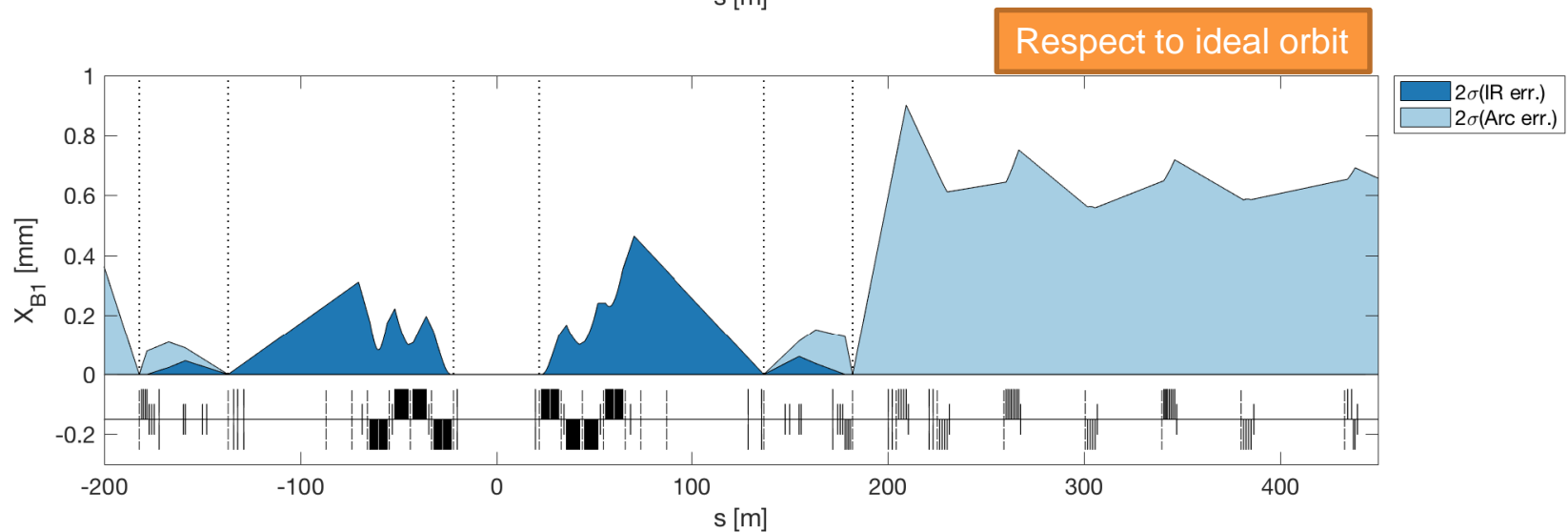
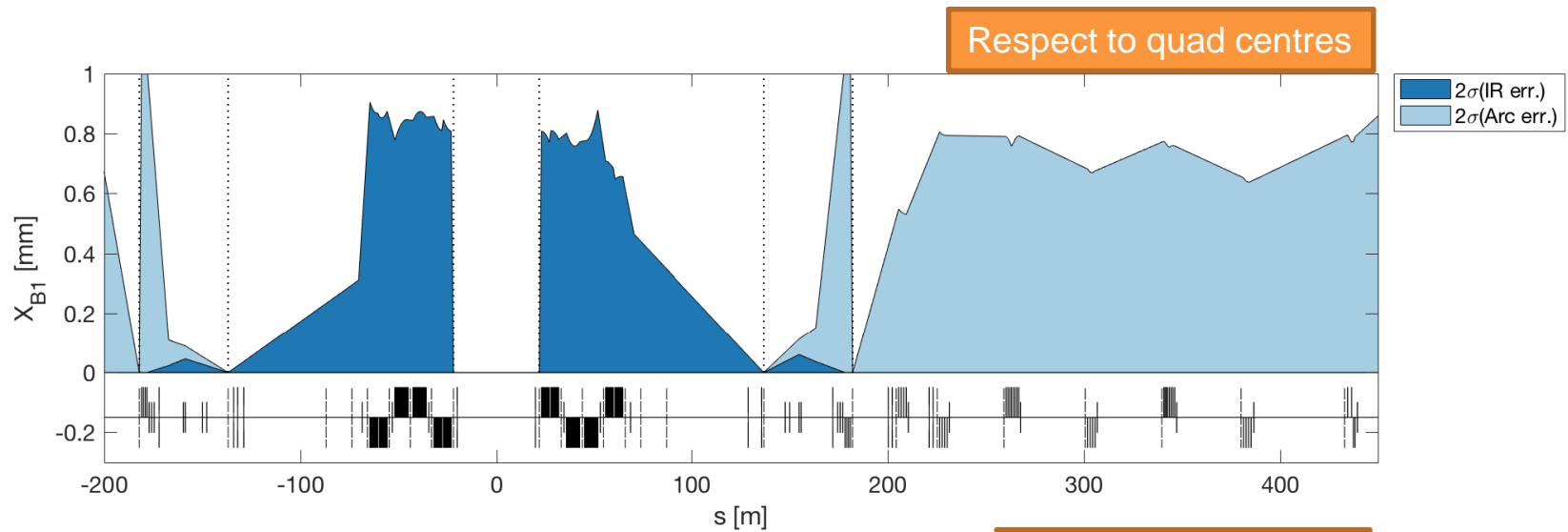

Residual orbit 2c (respect to ideal orbit) [mm]

Element	IR err. [2*std]	Arc err. [2*std]	Lumi scan. [±0.1 mm]	Cros. [±250 μrad]	Sep. [±0.75 mm]	IP Off. [±2 mm] ***	CC B1 adjust [±0.5 mm]	CC B2 adjust [±0.5 mm]
TAXS X Y [mm]	0	0	0.1	4.99	0.75	2	0	0
MQXFA.[AB]1 X Y [mm]	0.14	0	0.12	9.34	0.91	2.27	0	0
MQXFB.[AB]2 X Y [mm]	0.24	0	0.16	14.14	1.19	2.62	0.1	0.1
MQXFA.[AB]3 X Y [mm]	0.35	0	0.1	14.12	0.8	2.46	0.21	0.21
MBXF X Y [mm]	0.43	0	0.03	12.63	0.45	1.00	0.23	0.23
TAXN X Y [mm]	0.06	0	0.14	3.3	0.13	0.48	0.42	0.42
MBRD X Y [mm]	0.07	0	0.19	1.45	0.06	0.24	0.48	0.48
MCBRD X Y [mm]	0.08	0.02	0.2	0.25	0.01	0.05	0.5	0.5
MCBY[HV].[AB]?4 X Y [mm]	0.01	0.25	0.1	0	0	0	0.5	0.5
MQY.4 X Y [mm]	0	0.17	0.09	0	0	0	0.48	0.48
TCLMC.5 X Y [mm]	0	0.84	0.02	0	0	0	0.25	0.25
MCBC[HV].5 X Y [mm]	0	0.95	0	0	0	0	0.21	0.21
MQML.5 X Y [mm]	0	0.93	0.01	0	0	0	0.22	0.22
TCLMC.6 X Y [mm]	0	0.82	0	0	0	0	0.07	0.07
MCBC[HV].6 X Y [mm]	0	0.88	0	0	0	0	0	0
MQML.6 X Y [mm]	0	0.86	0	0	0	0	0.04	0.04
MCBC[HV].7 X Y [mm]	0	0.77	0	0	0	0	0	0
MQM.[AB]7 X Y [mm]	0	0.75	0	0	0	0	0	0
MCBC[HV].8 X Y [mm]	0	0.93	0	0	0	0	0	0
MQML.8 X Y [mm]	0	0.9	0	0	0	0	0	0
MCBC[HV].9 X Y [mm]	0	0.73	0	0	0	0	0	0
MQMC.9 X Y [mm]	0	0.67	0	0	0	0	0	0
MQM.9 X Y [mm]	0	0.72	0	0	0	0	0	0
MCB[HV].10 X Y [mm]	0	0.94	0	0	0	0	0	0
MQML.10 X Y [mm]	0	0.91	0	0	0	0	0	0

*** It requires to translate Q1-Q4 of 2 mm in the direction of the required offset.

Residual orbit 2c (respect to quad center) [mm]

Element	IR err. [2*std]	Arc err. [2*std]	Lumi scan. [±0.1 mm]	Cros. [±250 μrad]	Sep. [±0.75 mm]	IP Off. [±2 mm] ***	CC B1 adjust [±0.5 mm]	CC B2 adjust [±0.5 mm]
TAXS X Y [mm]	0	0	0.1	4.99	0.75	2	0	0
MQXFA.[AB]1 X Y [mm]	0.86	0	0.12	9.34	0.91	1.37	0	0
MQXFB.[AB]2 X Y [mm]	0.88	0	0.16	14.14	1.19	1.72	0.1	0.1
MQXFA.[AB]3 X Y [mm]	0.91	0	0.1	14.12	0.8	0.96	0.21	0.21
MBXF X Y [mm]	0.43	0	0.03	12.63	0.45	0.68	0.23	0.23
TAXN X Y [mm]	0.06	0	0.14	3.3	0.13	0.48	0.42	0.42
MBRD X Y [mm]	0.07	0	0.19	1.45	0.06	0.24	0.48	0.48
MCBRD X Y [mm]	0.08	0.02	0.2	0.25	0.01	0.05	0.5	0.5
MCBY[HV].[AB]?4 X Y [mm]	0.01	0.25	0.1	0	0	0	0.5	0.5
MQY.4 X Y [mm]	0	1.04	0.09	0	0	0	0.48	0.48
TCLMC.5 X Y [mm]	0	0.84	0.02	0	0	0	0.25	0.25
MCBC[HV].5 X Y [mm]	0	0.95	0	0	0	0	0.21	0.21
MQML.5 X Y [mm]	0	0.89	0.01	0	0	0	0.22	0.22
TCLMC.6 X Y [mm]	0	0.82	0	0	0	0	0.07	0.07
MCBC[HV].6 X Y [mm]	0	0.88	0	0	0	0	0	0
MQML.6 X Y [mm]	0	0.85	0	0	0	0	0.04	0.04
MCBC[HV].7 X Y [mm]	0	0.77	0	0	0	0	0	0
MQM.[AB]7 X Y [mm]	0	0.84	0	0	0	0	0	0
MCBC[HV].8 X Y [mm]	0	0.93	0	0	0	0	0	0
MQML.8 X Y [mm]	0	0.68	0	0	0	0	0	0
MCBC[HV].9 X Y [mm]	0	0.73	0	0	0	0	0	0
MQMC.9 X Y [mm]	0	0.9	0	0	0	0	0	0
MQM.9 X Y [mm]	0	0.84	0	0	0	0	0	0
MCB[HV].10 X Y [mm]	0	0.94	0	0	0	0	0	0
MQML.10 X Y [mm]	0	0.65	0	0	0	0	0	0

*** It requires to translate Q1-Q4 of 2 mm in the direction of the required offset.

Knobs B

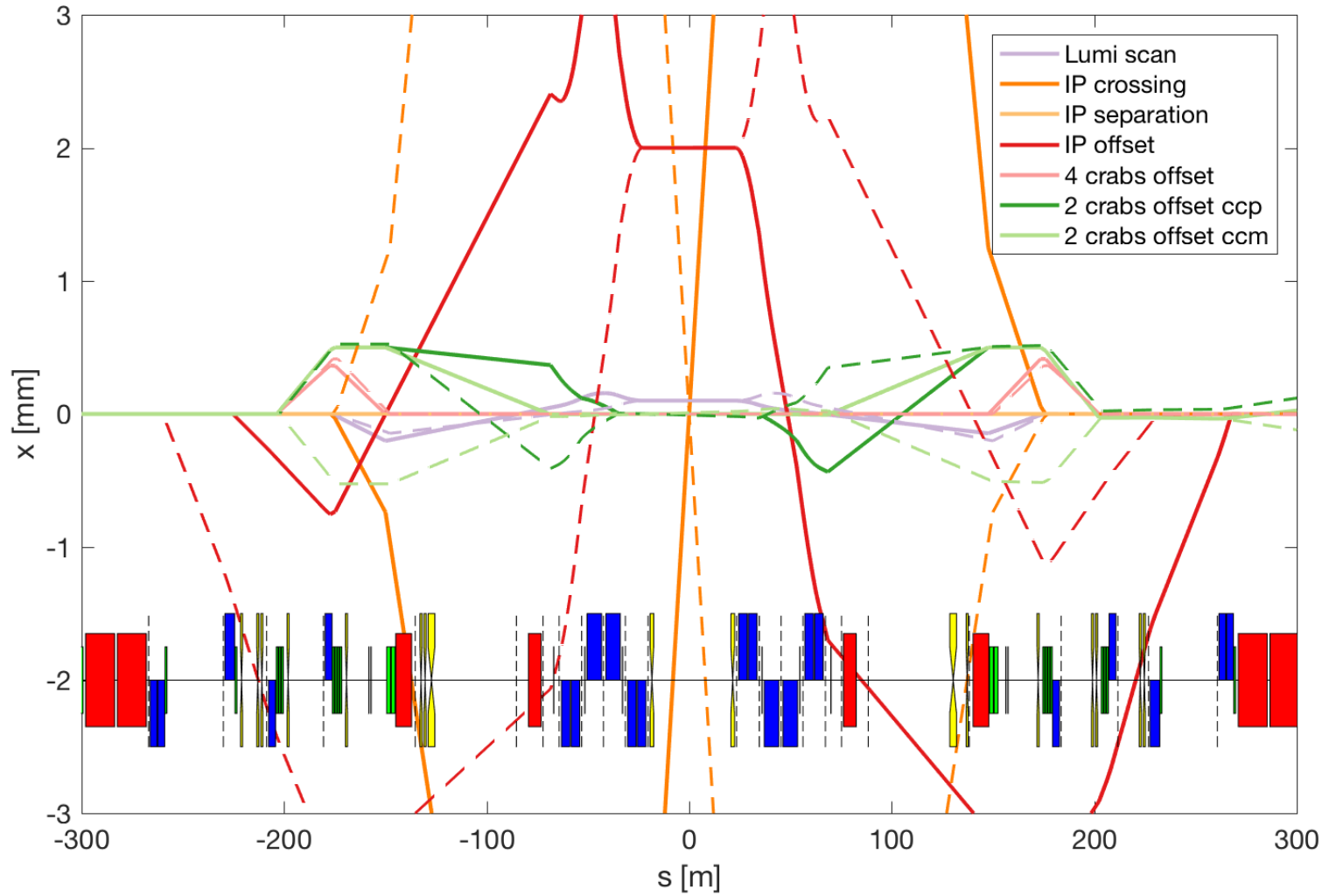

Option 1B

HL-LHC Option 1b Orbit corrector layout

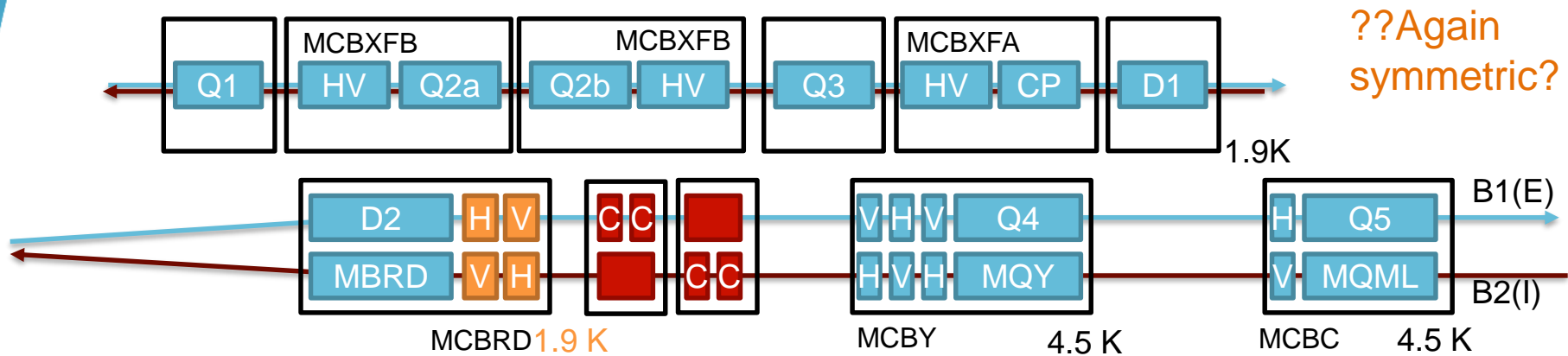

HL-LHC baseline designed to:

- Correct quadrupole misalignments and dipole tilt and transfer function errors based on LHC experience.
- **Not** compatible with potential installation of 2 additional crab cavities.
- **Reduced** control orbit at the crab cavities.
- Adjust the IP position limiting the realignment of HW components (crab cavities only).

Layout changes with respect to the baseline:

- Q4: removing 1 corrector, reusing existing cold mass, no need of 1.9 K
- Q5: removing 2 correctors, reusing existing Q5 cold mass.

Orbit Option 1b corrector budget

No W corr.

Right Point 5, H crossing, 2σ strength for errors

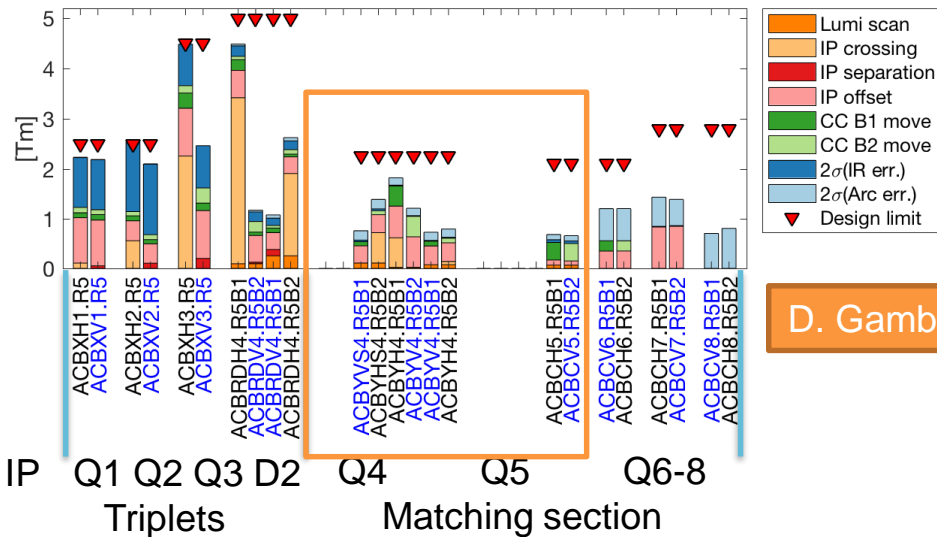

D. Gamba

For the Left and Point 1 symmetries applies:

- Left B1 -> Right B2,
- Left B2 -> Right B1
- H Point 5-> V Point 1

Knobs (Horizontal and Vertical):

- **IP crossing** ($\pm 250 \mu\text{rad}$), **separation** ($\pm 0.75 \text{ mm}$), **offset**: ($\pm 2.0 \text{ mm}$)
- **Luminosity** scan (individual beam IP shift of $\pm 100 \mu\text{m}$)
- **Limited** beam alignment in the crab cavities: 2 cavities (orbit adjust ± 0.5 different beam both planes) (**knob up to Q6**)

Machine errors (**uniformly distributed, uncorrelated**):

- **0.58 mm max** transverse displacement of quadrupoles at the IT (**IR. err.**)
- **0.6 mm max** transverse displacement of quadrupoles in the arc (**Arc. err.**).
- **10 mm max** longitudinal displacement, **0.5 mrad max** roll, **0.2% max** field error for D1 and D2 (**IR err.**) and in the arcs (**Arc err.**).

Residual orbit 1b (0.6 mm DX/DY...)

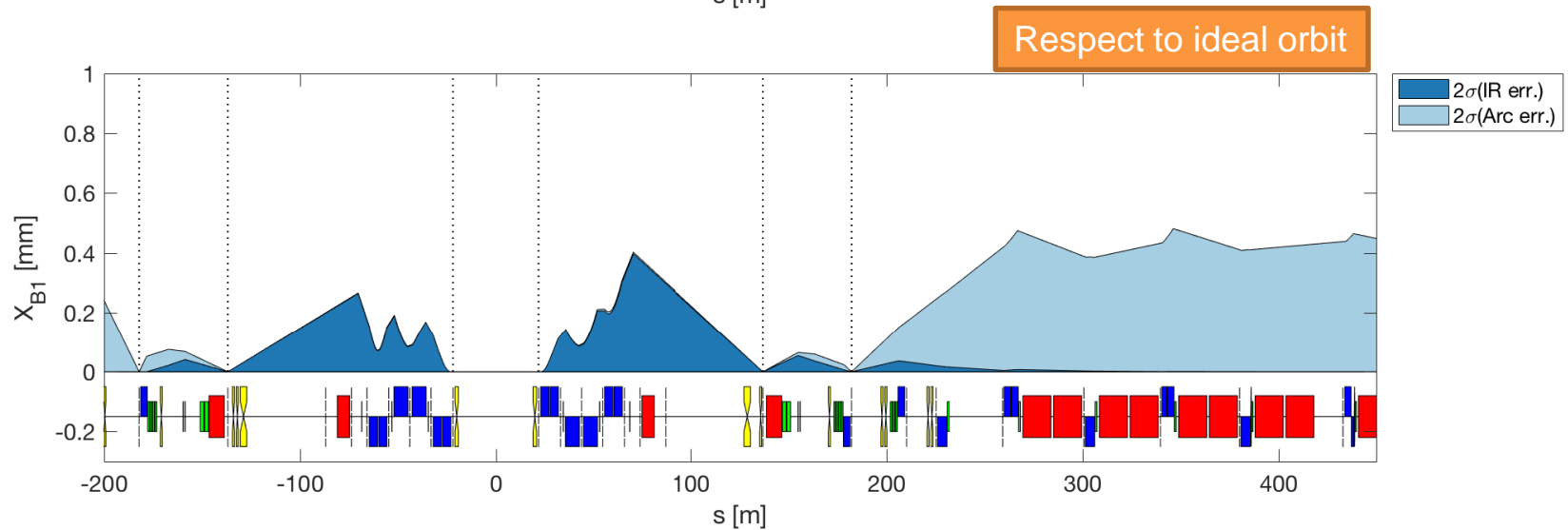
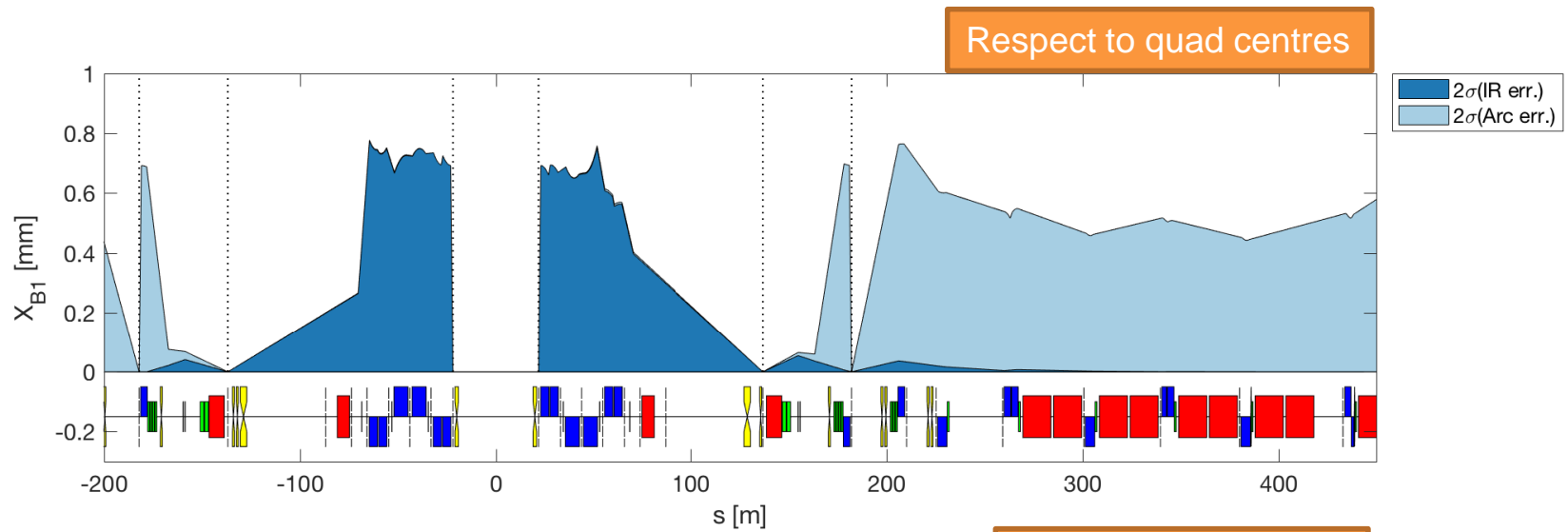

Assumptions (errors)

- *For the time being we consider each aperture as independent.*
- Errors defined **w.r.t. ideal machine** (MAD-X), and the **magnetic center** of each single aperture.
- Errors are assumed to be represent the **worst case within two alignment campaigns**.
- All errors are given as \pm maximum value, assuming square distributions
 - (i.e. if ± 0.5 mm, then r.m.s. = $0.5/\sqrt{3}$ = 0.29 mm)
- Alignment error for all type of **quadrupoles**:
 - ± 0.5 mm transverse (DX/DY), ± 10 mm (should probably be better => ± 3 mm?) longitudinal (DS), ± 1 mrad roll (DPSI), [± 0.002 relative strength error]
 - pitch and yaw are assumed to be 0 (i.e. their effect is assumed to be “included” in the ± 0.5 mm transverse error).
- Alignment error for all type of **dipoles**:
 - ± 10 mm (should probably be better => ± 3 mm?) longitudinal (DS), ± 0.5 mrad roll (DPSI), [± 0.002 relative strength error]
 - transverse alignment, pitch and yaw should not have major impact, so they are assumed to be zero.
- Alignment error for **crab cavities** (with respect to the RF center):
 - The assumption being used by AWG is to have all cavities aligned within to **0.5 mm (3 sigma)**.
- Alignment error for instrumentation and other equipment (e.g. valves):
 - Assumption is that the standard alignment will be good enough not to affect aperture (better than ± 2 mm(?))
- ± 2.5 mm transverse adjustments on cold machine and under vacuum possible (with or without remote control) (minutes of AWG meeting #1 – [EDMS1856717](#))
- ± 10 mm general adjustment capabilities of supports (112 WP2 meeting – Mateusz [presentation](#))

Survey-fiducialization tolerances

	Ground motion			Fiducialization		
	r [mm]	h [mm]	v [mm]	r [mm]	h [mm]	v [mm]
TAXS (*)	2.0	0	0	0	0.5	0.5
Triplets	0.6	0	0	0	1.0	1.0
BPMs	0	0	0	2.5	0	0
TAXN (*)	0.84	0.36	0	0	1.0	1.0
D1	0.6	0.36	0	0	1.0	1.0
D2/Q4/Q5	0.84	0.36	0	0	0.9	0.6

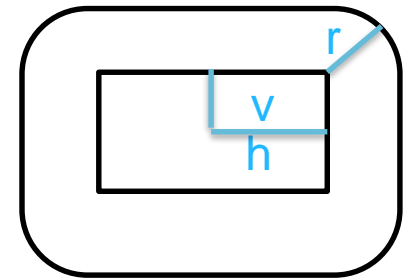

Value derived from J. Jeanneret, LHC rep 1007 but to be validated by survey, WP3, WP8 teams.

Values for experimental beam pipe under discussions

Still shape tolerances needs to be subtracted from the available aperture.

Vacuum shapes (minimum inner diameter)

	Shape	Design [mm]	With mech. tol. [mm]	Sep [mm]
TAXS	Circle	tbd	60	n/a
Q1	Octagon	99.7(hv), 99.7(45°)	94.94(hv), 94.94(45°)	n/a
Q2-D1	Octagon	119.7(hv), 110.7(45°)	115.3(hv), 106.3(45°)	n/a
TAXN	Circle	tbd	85	158-148
D2	Octagon	86(hv), 77(45°)	83(hv), 74(45°)	188
Q4-Q5	Rectellipse	61.4(r), 51.8(g)	57.8(r), 48(g)	194
Q6	Rectellipse	48.5(r), 38.9(g)	45.1(r), 35.3(g)	194

IR1/5	Left	Right
Q4	HV	VH
Q5	HV	VH
Q6	HV	VH

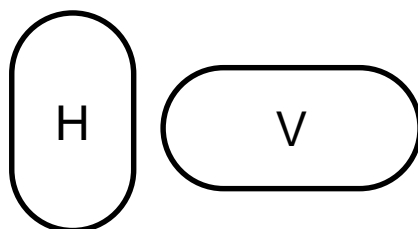

C. Garion, 30/11/2015
LHC-VSS-ES-0002 rev1.2, 2004

Aperture Margins: Round 15 cm, 12.5σ

	Bare	Mech	Beam	Crab	Offset
TAXS	24.0	21.4	17.3	17.3	15.1
MQXFA.[AB]1	21.2	19.4	16.4	16.4	15.1
MQXF[AB].[23]	15.5	14.4	12.2	12.0	11.0
MBXF	16.9	16.0	13.6	13.5	12.7
TAXN	22.3	20.9	17.7	17.2	15.5
MBRD	26.7	23.7	19.9	19.0	16.4
MCBRD	29.2	26.3	22.1	21.2	18.3
TCLMB.4	24.9	23.3	19.0	18.0	14.7
MCBY[HV].[AB]?4	26.2	24.1	19.6	18.6	15.1
MQY.4	29.2	26.6	21.7	20.7	17.1
TCLMB.5	36.3	34.3	28.7	28.5	25.2
MCBY[HV].[AB]?5	37.5	35.3	29.4	29.4	26.2
MQY.5	39.4	37.1	31.0	31.0	27.9
TCLMC.6	37.0	34.4	28.1	28.1	25.6
MCBC[HV].6	38.2	35.9	29.4	29.4	27.2
MQML.6	38.6	35.8	29.3	29.3	27.1

$$\theta_c = \pm 295 \mu\text{rad};$$
$$d_{\text{sep}} = \pm 0.75 \text{ mm};$$

needs phase $\leq 30^\circ$ and slightly reduced margins

Aperture in σ at $2.5 \mu\text{m}/\gamma$ at 7 TeV

Aperture Margins: Round 15 cm , 10 σ

	Bare	Mech	Beam	Crab	Offset
TAXS	25.3	22.7	18.5	18.5	16.2
MQXFA.[AB]1	22.4	20.7	17.5	17.5	16.3
MQXF[AB].[23]	16.8	15.7	13.3	13.2	12.1
MBXF	18.2	17.3	14.7	14.6	13.8
TAXN	22.9	21.6	18.3	17.8	16.1
MBRD	27.1	24.1	20.2	19.3	16.8
MCBRD	29.5	26.5	22.4	21.4	18.6
TCLMB.4	25.0	23.4	19.0	18.1	14.8
MCBY[HV].[AB]?4	26.2	24.1	19.7	18.7	15.1
MQY.4	29.2	26.6	21.7	20.7	17.1
TCLMB.5	36.3	34.3	28.7	28.5	25.2
MCBY[HV].[AB]?5	37.6	35.3	29.4	29.4	26.2
MQY.5	39.4	37.1	31.0	31.0	27.9
TCLMC.6	37.0	34.4	28.1	28.1	25.6
MCBC[HV].6	38.2	35.9	29.4	29.4	27.2
MQML.6	38.6	35.9	29.3	29.3	27.1

$$\theta_c = \pm 235 \text{ } \mu\text{rad};$$
$$d_{\text{sep}} = \pm 0.75 \text{ mm};$$

needs phase $\leq 40^\circ$

Aperture in σ at 2.5 $\mu\text{m}/\gamma$ at 7 TeV

Aperture Margins: Round 20 cm, 12.5 σ

	Bare	Mech	Beam	Crab	Offset
TAXS	28.7	25.7	20.9	20.9	18.3
MQXFA.[AB]1	25.4	23.4	19.9	19.9	18.4
MQXF[AB].[23]	18.9	17.6	15.0	14.8	13.6
MBXF	20.5	19.5	16.6	16.5	15.6
TAXN	26.2	24.7	20.9	20.4	18.4
MBRD	31.1	27.7	23.3	22.3	19.3
MCBRD	34.0	30.6	25.8	24.7	21.4
TCLMB.4	28.9	26.9	22.0	20.9	17.1
MCBY[HV].[AB]?4	30.3	27.9	22.7	21.6	17.5
MQY.4	33.7	30.8	25.1	24.0	19.8
TCLMB.5	41.9	39.6	33.1	32.9	29.2
MCBY[HV].[AB]?5	43.4	40.7	34.0	34.0	30.3
MQY.5	45.5	42.9	35.8	35.8	32.3
TCLMC.6	42.7	39.6	32.4	32.4	29.5
MCBC[HV].6	44.0	41.4	34.0	34.0	31.4
MQML.6	44.5	41.4	33.8	33.8	31.3

$$\theta_c = \pm 255 \mu\text{rad};$$
$$d_{\text{sep}} = \pm 0.75 \text{ mm};$$

needs phase $\leq 55^\circ$

Aperture in σ at 2.5 $\mu\text{m}/\gamma$ at 7 TeV

Aperture Margins: Round 20 cm, 10 σ

	Bare	Mech	Beam	Crab	Offset
TAXS	29.9	26.9	22.0	22.0	19.3
MQXFA.[AB]1	26.6	24.6	21.0	21.0	19.5
MQXF[AB].[23]	20.1	18.9	16.1	16.0	14.7
MBXF	21.7	20.7	17.7	17.6	16.7
TAXN	26.9	25.4	21.5	21.0	19.0
MBRD	31.5	28.1	23.6	22.6	19.6
MCBRD	34.2	30.8	26.0	24.9	21.6
TCLMB.4	29.0	27.0	22.1	21.0	17.2
MCBY[HV].[AB]?4	30.3	27.9	22.8	21.6	17.5
MQY.4	33.7	30.8	25.1	24.0	19.8
TCLMB.5	41.9	39.6	33.1	32.9	29.2
MCBY[HV].[AB]?5	43.4	40.8	34.0	34.0	30.3
MQY.5	45.5	42.9	35.8	35.8	32.3
TCLMC.6	42.7	39.6	32.4	32.4	29.5
MCBC[HV].6	44.0	41.4	34.0	34.0	31.4
MQML.6	44.5	41.4	33.8	33.8	31.3

$$\theta_c = \pm 205 \text{ } \mu\text{rad};$$
$$d_{\text{sep}} = \pm 0.75 \text{ mm};$$

Ok for any phase

Aperture in σ at 2.5 $\mu\text{m}/\gamma$ at 7 TeV

Aperture Margins: Flat 15/40 cm

	Bare	Mech	Beam	Crab	Offset
TAXS	29.8	27.1	22.5	22.5	20.1
MQXFA.[AB]1	27.4	25.7	22.1	22.1	20.8
MQXF[AB].[23]	21.8	20.8	17.9	17.8	16.7
MBXF	23.1	22.2	19.2	19.1	18.3
TAXN	25.5	24.2	20.7	20.2	18.4
MBRD	29.3	26.8	22.8	22.2	20.2
MCBRD	31.9	29.5	25.2	24.5	22.3
TCLMB.4	25.4	23.7	19.3	18.4	15.1
MCBY[HV].[AB]?4	26.4	24.4	19.8	18.8	15.3
MQY.4	29.3	26.7	21.8	20.8	17.1
TCLMB.5	36.4	34.3	28.7	28.5	25.4
MCBY[HV].[AB]?5	37.6	35.4	29.6	29.5	26.3
MQY.5	39.4	37.2	31.1	31.1	28.1
TCLMC.6	37.2	34.5	28.2	28.2	25.6
MCBC[HV].6	38.5	36.1	29.5	29.5	27.8
MQML.6	38.6	35.9	29.3	29.3	27.1

$$\theta_c = \pm 210 \text{ } \mu\text{rad};$$
$$d_{\text{sep}} = \pm 0.75 \text{ mm};$$

Ok any phase

Aperture in σ at $2.5 \text{ } \mu\text{m}/\gamma$ at 7 TeV

Aperture Margins: Flat 10/40 cm

	Bare	Mech	Beam	Crab	Offset
TAXS	23.9	21.7	17.9	17.9	15.9
MQXFA.[AB]1	21.9	20.6	17.6	17.6	16.6
MQXF[AB].[23]	17.4	16.6	14.3	14.2	13.3
MBXF	18.0	17.3	14.8	14.7	14.1
TAXN	20.8	19.7	16.8	16.4	15.0
MBRD	22.3	20.3	17.2	16.7	15.1
MCBRD	24.5	22.2	18.8	18.3	16.5
TCLMB.4	20.7	19.3	15.7	14.9	12.2
MCBY[HV].[AB]?4	21.6	19.9	16.1	15.3	12.4
MQY.4	23.9	21.8	17.7	16.9	13.9
TCLMB.5	29.7	28.0	23.4	23.2	20.7
MCBY[HV].[AB]?5	30.7	28.9	24.1	24.0	21.5
MQY.5	32.2	30.4	25.4	25.4	22.9
TCLMC.6	30.4	28.2	23.0	23.0	20.9
MCBC[HV].6	31.5	29.5	24.1	24.1	22.7
MQML.6	31.6	29.3	23.9	23.9	22.1

$$\theta_c = \pm 210 \text{ } \mu\text{rad};$$
$$d_{\text{sep}} = \pm 0.75 \text{ mm};$$

Needs phase $< 40^\circ$

Aperture in σ at $2.5 \text{ } \mu\text{m}/\gamma$ at 7 TeV

Aperture Margins: Flat 10/40 cm

	Bare	Mech	Beam	Crab	Offset
TAXS	23.9	21.7	17.9	17.9	15.9
MQXFA.[AB]1	21.9	20.6	17.6	17.6	16.6
MQXF[AB].[23]	17.4	16.6	14.3	14.2	13.3
MBXF	18.0	17.3	14.8	14.7	14.1
TAXN	20.8	19.7	16.8	16.4	15.0
MBRD	22.3	20.3	17.2	16.7	15.1
MCBRD	24.5	22.2	18.8	18.3	16.5
TCLMB.4	20.7	19.3	15.7	14.9	12.2
MCBY[HV].[AB]?4	21.6	19.9	16.1	15.3	12.4
MQY.4	23.9	21.8	17.7	16.9	13.9
TCLMC.5	23.2	21.5	17.5	17.3	14.7
MCBC[HV]. 5	24.0	22.0	17.9	17.8	15.2
MQML.5	25.1	23.2	18.8	18.8	16.3
TCLMC.6	30.4	28.2	23.0	23.0	20.9
MCBC[HV].6	31.5	29.5	24.1	24.1	22.7
MQML.6	31.6	29.3	23.9	23.9	22.1

$$\theta_c = \pm 210 \text{ } \mu\text{rad};$$
$$d_{\text{sep}} = \pm 0.75 \text{ mm};$$

Needs phase $< 40^\circ$

If Q5 is replaced by MQML
TCT.6 strictly needed and
no big gain with MQYY anymore

Aperture in σ at $2.5 \text{ } \mu\text{m}/\gamma$ at 7 TeV

Aperture Margins: Round 15 cm, 10.5 σ

	Bare	Mech	Beam	Crab	Offset
TAXS	25.1	22.6	18.5	18.5	16.3
MQXFA.[AB]1	22.1	20.5	17.4	17.4	16.2
MQXF[AB].[23]	16.5	15.5	13.2	13.1	12.0
MBXF	17.2	16.3	13.9	13.7	12.9
TAXN	22.9	21.6	18.4	17.9	16.2
MBRD	25.6	22.7	19.0	18.1	15.5
MCBRD	26.9	24.0	20.1	19.1	16.3
TCLMB.4	25.3	23.0	18.8	17.9	14.5
MCBY[HV].[AB]?4	26.6	24.3	19.9	18.8	15.3
MQY.4	29.0	26.8	22.0	21.0	17.3
TCLMB.5	36.1	33.9	28.3	28.2	24.8
MCBY[HV].[AB]?5	37.3	35.2	29.4	29.3	26.2
MQY.5	39.2	37.1	31.0	31.0	27.9
TCLMC.6	36.6	34.2	28.0	28.0	25.5
MCBC[HV].6	37.7	35.5	29.0	29.0	26.4
MQML.6	38.1	35.4	29.0	29.0	26.8

$\theta_c = \pm 250 \mu\text{rad}$;
 $d_{\text{sep}} = \pm 0.0 \text{ mm}$;

Aperture in σ at 2.5 $\mu\text{m}/\gamma$ at 7 TeV

Aperture Margins: Flat 18/7.5 cm, 11.3 σ

	Bare	Mech	Beam	Crab	Offset
TAXS	21.0	19.1	15.8	15.8	14.0
MQXFA.[AB]1	19.4	18.2	15.7	15.7	14.8
MQXF[AB].[23]	15.4	14.7	12.7	12.6	11.8
MBXF	15.7	15.0	13.0	12.8	12.3
TAXN	18.1	17.1	14.6	14.3	13.0
MBRD	19.4	17.6	15.0	14.5	13.0
MCBRD	21.3	19.3	16.4	15.9	14.1
TCLMB.4	18.0	16.4	13.4	12.7	10.4
MCBY[HV].[AB]?4	19.0	17.3	14.1	13.4	10.9
MQY.4	20.5	19.0	15.5	14.8	12.2
TCLMB.5	25.5	24.0	20.0	19.9	17.7
MCBY[HV].[AB]?5	26.4	24.9	20.8	20.7	18.5
MQY.5	27.7	26.3	21.9	21.9	19.8
TCLMC.6	26.0	24.3	19.8	19.8	18.0
MCBC[HV].6	26.9	25.2	20.6	20.6	18.8
MQML.6	27.0	25.1	20.5	20.5	19.0

$\theta_c = \pm 240 \mu\text{rad}$;
 $d_{\text{sep}} = \pm 0.0 \text{ mm}$;

Aperture in σ at 2.5 $\mu\text{m}/\gamma$ at 7 TeV

Aperture Margins: Flat 30/7.5 cm, 14.5 σ

	Bare	Mech	Beam	Crab	Offset
TAXS	21.1	19.2	15.9	15.9	14.2
MQXFA.[AB]1	19.4	18.2	15.7	15.7	14.8
MQXF[AB].[23]	15.5	14.7	12.7	12.6	11.8
MBXF	15.7	15.0	13.0	12.9	12.3
TAXN	18.1	17.1	14.6	14.3	13.1
MBRD	19.4	17.6	15.0	14.5	13.2
MCBRD	21.3	19.3	16.4	15.9	14.4
TCLMB.4	18.0	16.5	13.4	12.7	10.4
MCBY[HV].[AB]?4	19.0	17.3	14.1	13.4	10.9
MQY.4	20.6	19.0	15.5	14.8	12.2
TCLMB.5	25.6	24.0	20.0	19.9	17.7
MCBY[HV].[AB]?5	26.4	24.9	20.8	20.7	18.5
MQY.5	27.8	26.3	21.9	21.9	19.8
TCLMC.6	26.0	24.3	19.9	19.9	18.0
MCBC[HV].6	26.9	25.2	20.6	20.6	18.8
MQML.6	27.0	25.1	20.5	20.5	19.0

$\theta_c = \pm 245 \mu\text{rad}$;

$d_{\text{sep}} = \pm 0.0 \text{ mm}$;

Aperture in σ at 2.5 $\mu\text{m}/\gamma$ at 7 TeV

Aperture Margins: Round 15 cm, 10.5 σ

	Bare	Mech	Beam	Crab	Offset
TAXS	25.1	22.6	18.5	18.5	16.3
MQXFA.[AB]1	22.1	20.5	17.4	17.4	16.2
MQXF[AB].[23]	16.5	15.5	13.2	13.1	12.0
MBXF	17.2	16.3	13.9	13.7	12.9
TAXN	22.9	21.6	18.4	17.9	16.2
MBRD	25.6	22.7	19.0	18.1	15.5
MCBRD	26.9	24.0	20.1	19.1	16.3
TCLMB.4	25.3	23.0	18.8	17.9	14.5
MCBY[HV].[AB]?4	26.6	24.3	19.9	18.8	15.3
MQY.4	29.0	26.8	22.0	21.0	17.3
TCLMB.5	36.1	33.9	28.3	28.2	24.8
MCBY[HV].[AB]?5	37.3	35.2	29.4	29.3	26.2
MQY.5	39.2	37.1	31.0	31.0	27.9
TCLMC.6	36.6	34.2	28.0	28.0	25.5
MCBC[HV].6	37.7	35.5	29.0	29.0	26.4
MQML.6	38.1	35.4	29.0	29.0	26.8

$\theta_c = \pm 250 \mu\text{rad}$;
 $d_{\text{sep}} = \pm 0.0 \text{ mm}$;

Aperture in σ at 2.5 $\mu\text{m}/\gamma$ at 7 TeV