

Power Coupling

David Alesini

(LNF, INFN, Frascati, Italy)

CAS, Ebeltoft, Denmark, June 8th to 17th 2010

Outline

Basic concepts

coaxial/waveguide couplers
magnetic/electric coupling
coupling coefficient

Couplers for Standing Wave Normal Conducting Cavities

Couplers for Traveling Wave Structures

Couplers for Superconducting cavities

A lot of material (pictures, photos, drawings) has been taken from papers and presentations reported in the final references.

I would like to thank all authors for their help and contribution.

Introduction: what is a coupler

Power couplers transmit the power generated by the source to the cavity with a proper rate of energy. They are passive impedance matching networks designed to efficiently transfer power from an RF power source to a beam-loaded cavity operating under ultra-high vacuum conditions.

Two types of couplers can be used: **waveguide** type and **coaxial** type. Both have some advantages and disadvantages in terms of design, power handling capacity and tunability.

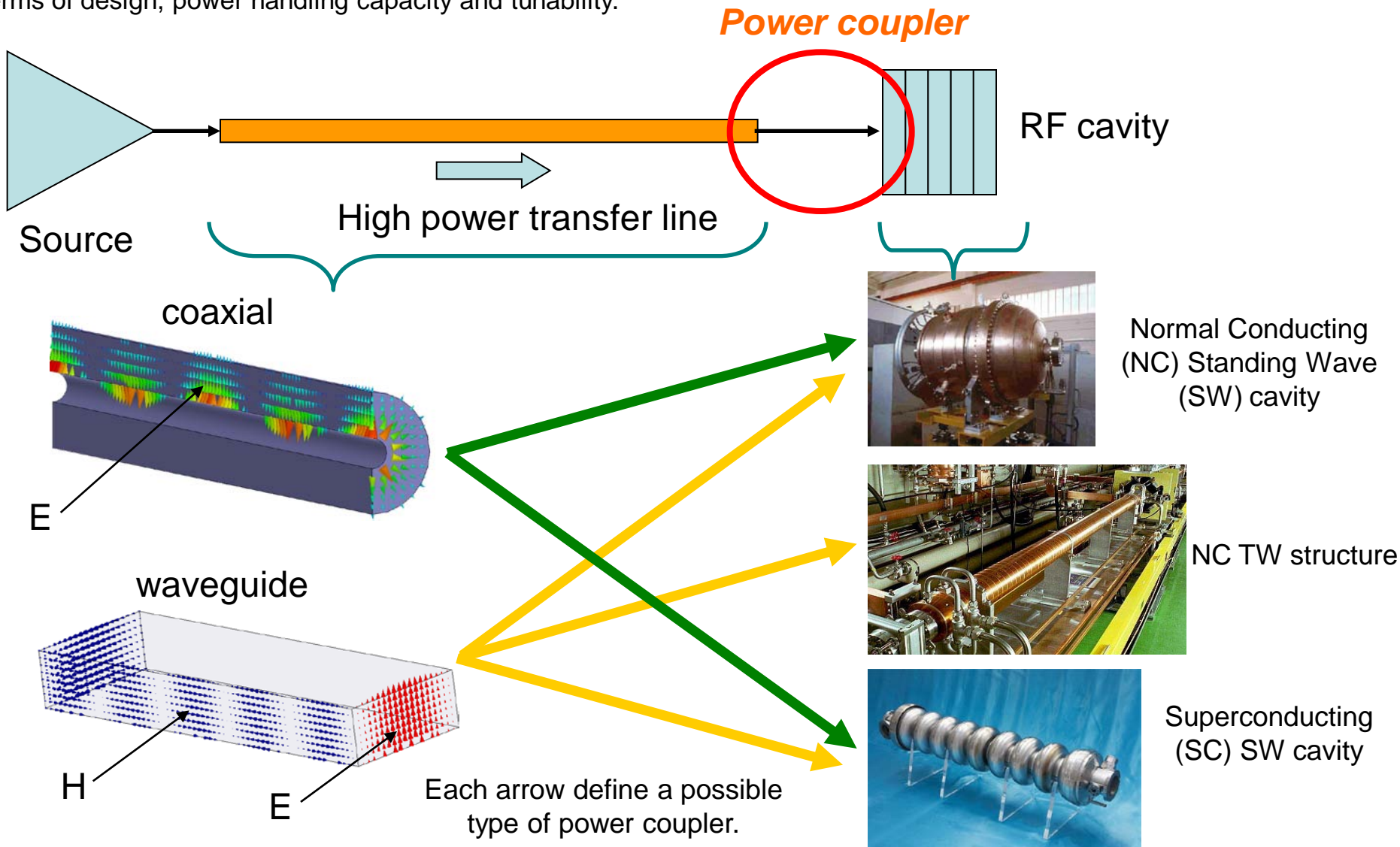

Introduction: important aspects in coupler design

- 1) In recent years the RF design of the couplers has been enormously aided by **computer codes** (such as HFSS, MAFIA, CST microwave studio). These codes allow complete modeling of the field distribution of the coupler/cavity minimizing the cut-and-try design technique used at origin.
- 2) As transmission lines, coaxial or waveguide, are usually filled with gas, couplers have to incorporate **vacuum barriers (RF windows)**.
- 3) For **superconducting cavities** an input coupler must serve as a **low-heat-leak thermal transition** between the room temperature environment outside and the cryogenic temperature (from 2 to 4.5 K). Thermal intercepts and/or active cooling in the coupler design might be necessary.
- 4) The coupler introduces an **asymmetry** in the electromagnetic field distribution which can deteriorate the beam quality. Special measures, such as using double couplers or compensating stubs, may be required.
- 5) Input couplers should be designed taking into consideration **pulsed heating** and **multipacting** phenomena.

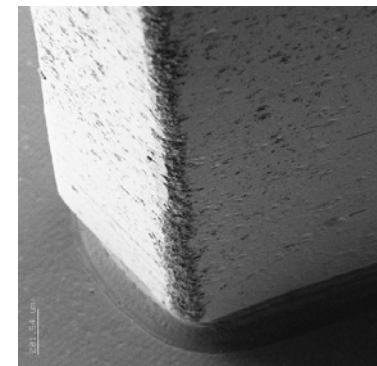
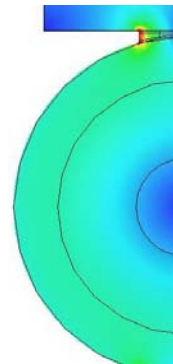
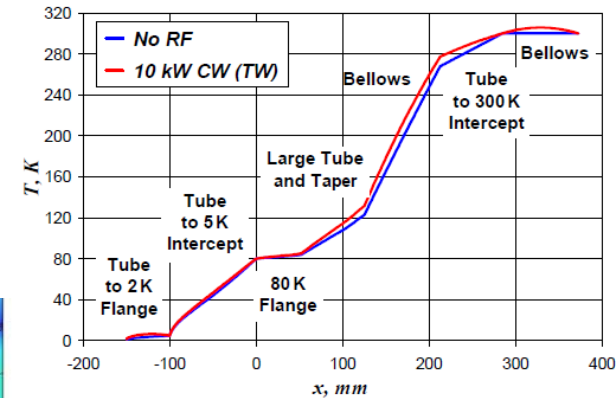
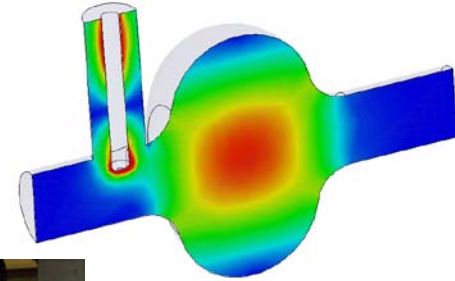

Magnetic coupling: slots on waveguides

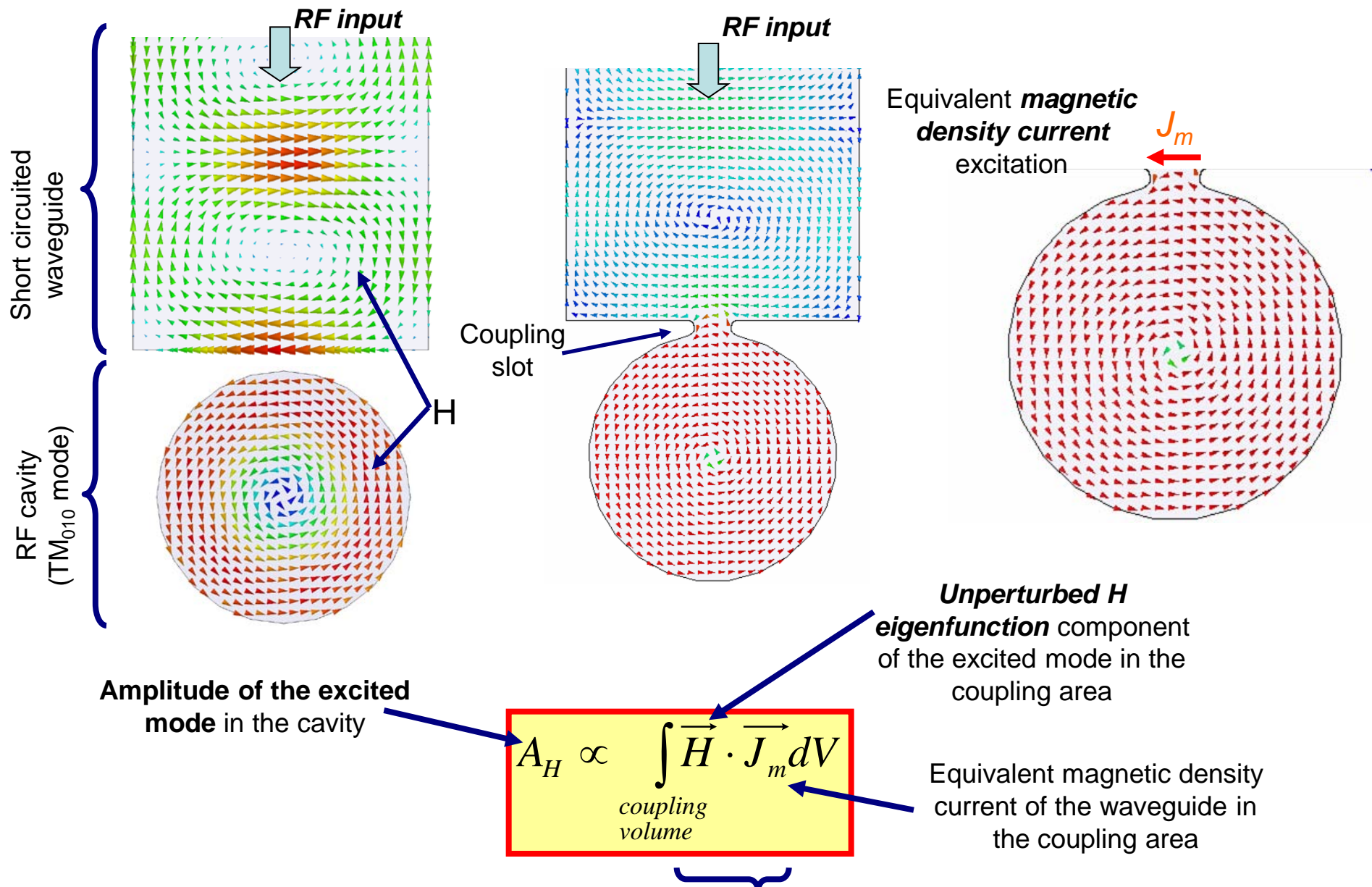

Both H and J_m should be different from zero and non orthogonal in order to have excitation of the mode

Magnetic coupling: longitudinal slots on waveguides

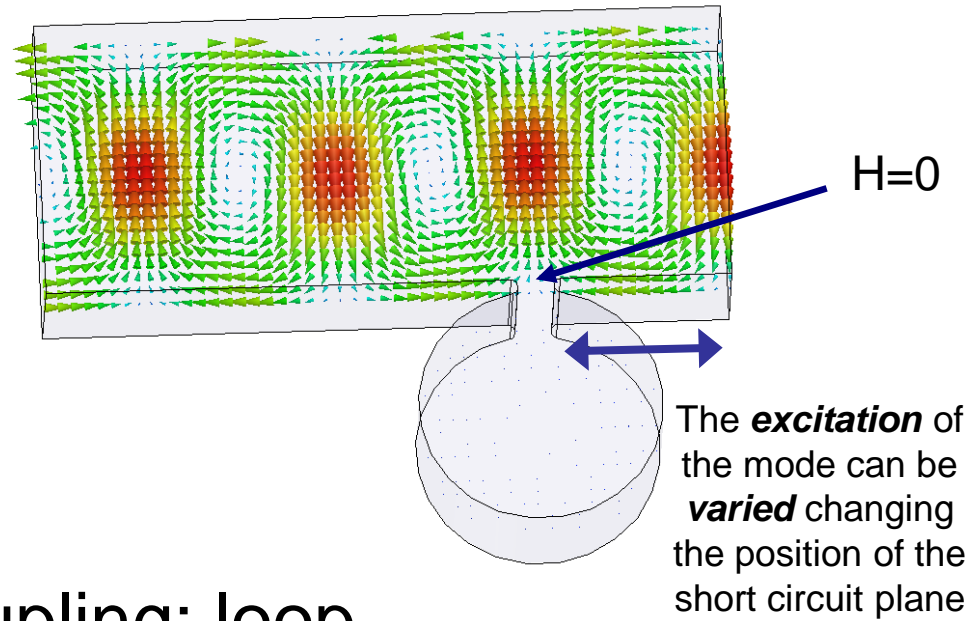
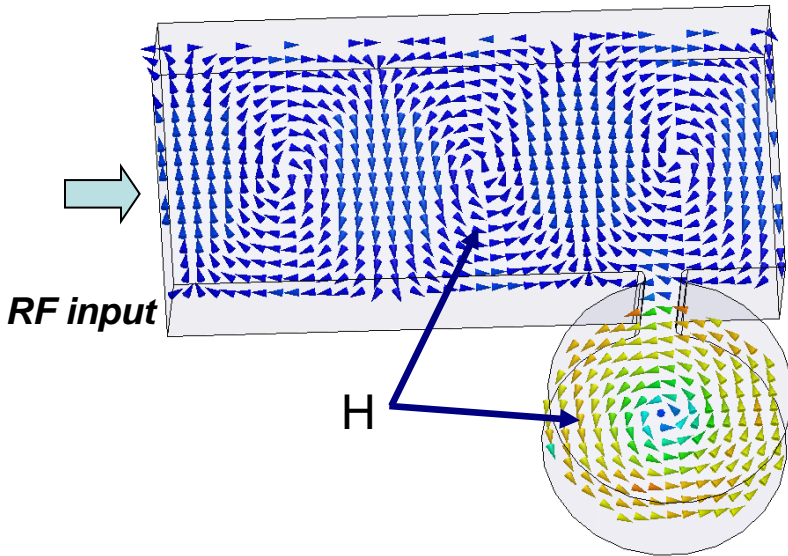

Magnetic coupling: loop

RF input

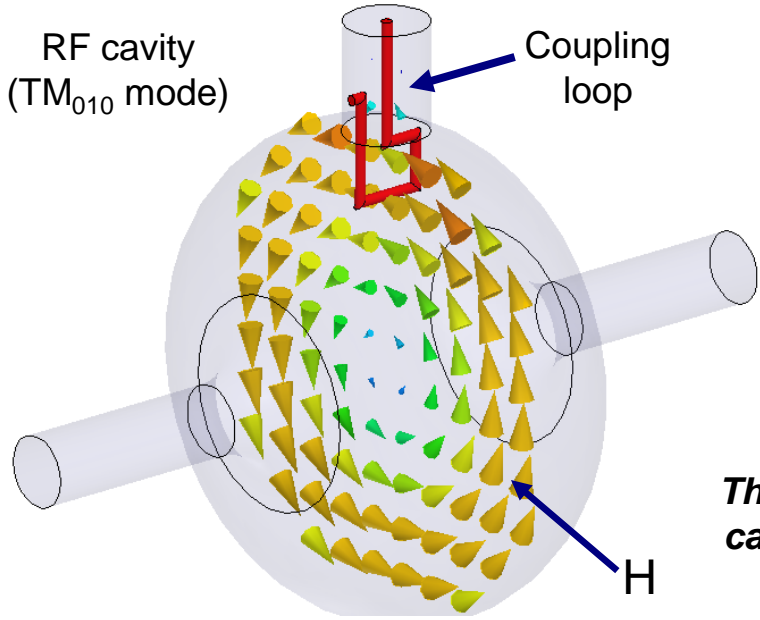

$$A_H \propto \int_{\text{coupling volume}} \vec{H} \cdot \vec{J}_m dV$$

The excitation of the mode can be varied changing the orientation of the loop

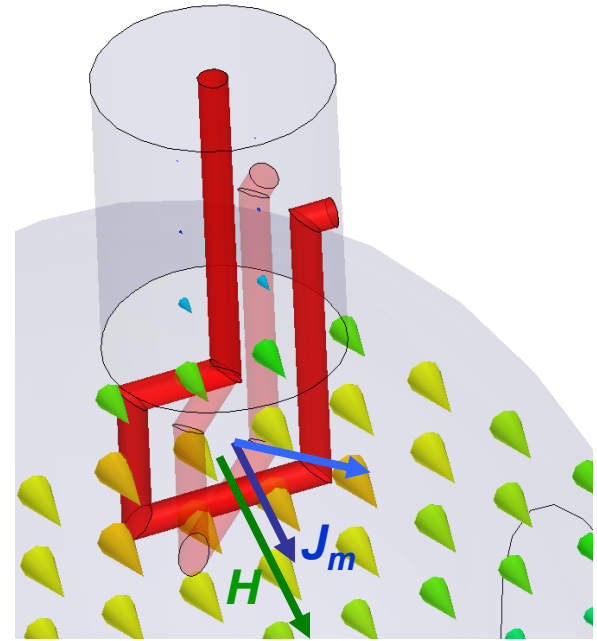

Electric coupling: antenna

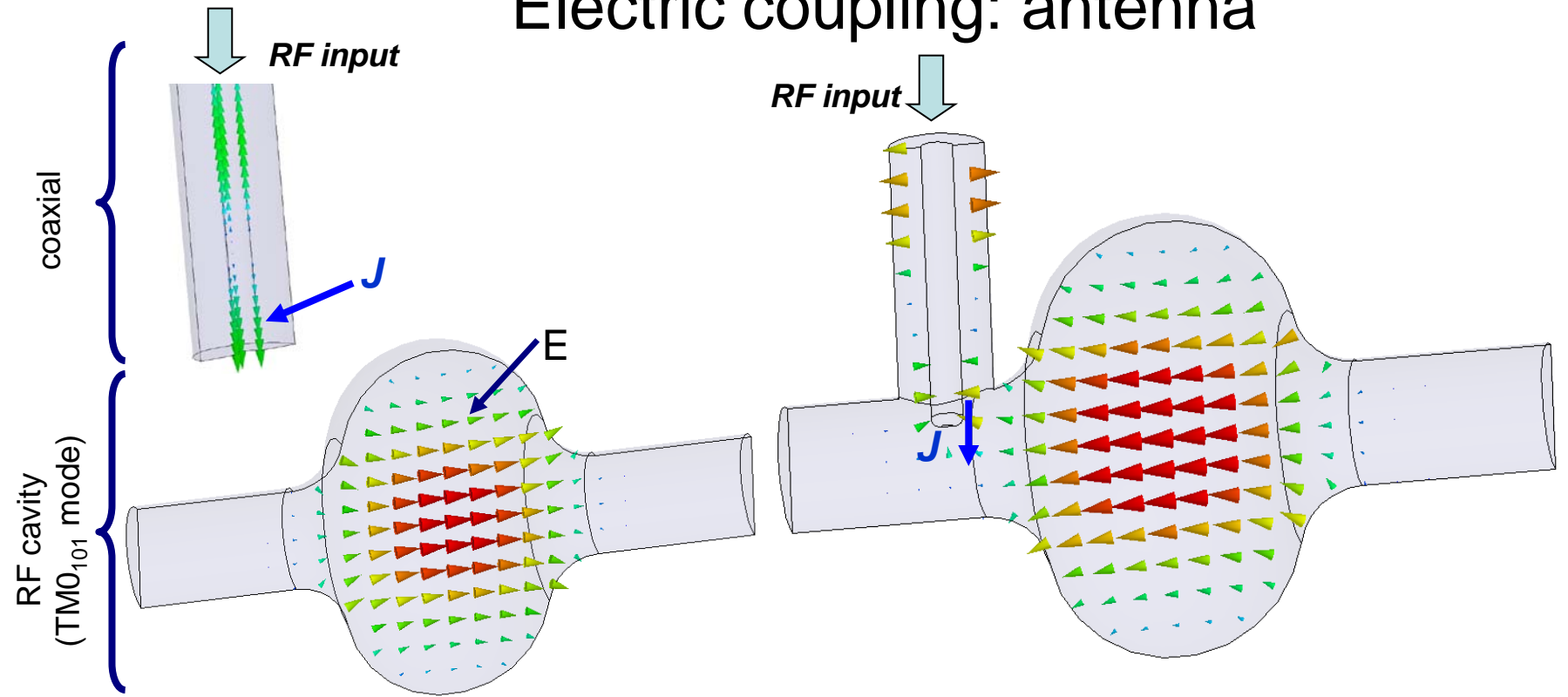

Amplitude of the excited mode in the cavity

$$A_E \propto \int_{\text{coupling volume}} \vec{E} \cdot \vec{J} dV$$

Unperturbed E eigenfunction component of the excited mode in the coupling area

Equivalent electric density current of the waveguide in the coupling area

Both E and J should be different from zero and non-orthogonal in order to have excitation of the mode

Circuit model coupler-SW cavity: coupling coefficient

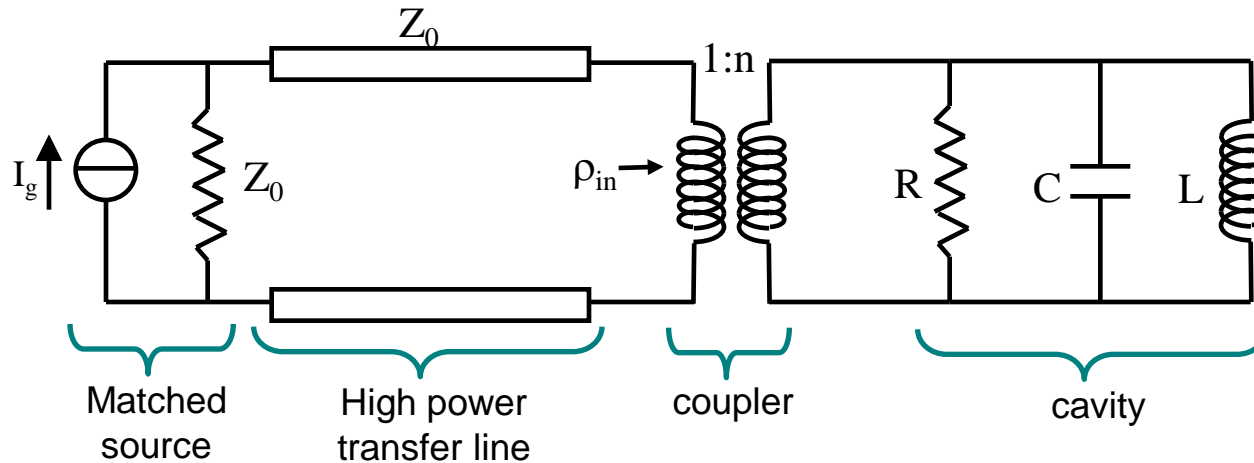

Resonant frequency of the cavity $f_{res} = \frac{1}{2\pi\sqrt{LC}}$ ($\omega_{res} = 2\pi f_{res}$)

Average dissipated power in the cavity P_{cav}

Average dissipated power in the source load P_{ext}

Coupling coefficient

$$\beta = \frac{P_{ext}}{P_{cav}} = \frac{R}{n^2 Z_0}$$

$$\rho_{in} = \frac{\beta - 1 + jQ_0\delta}{\beta + 1 + jQ_0\delta}$$

Unloaded quality factor

$$Q_0 = \frac{\omega_{res} W_{cav}}{P_{cav}}$$

External quality factor

$$Q_E = \frac{\omega_{res} W_{cav}}{P_{ext}}$$

Loaded quality factor

$$Q_L = \frac{\omega_{res} W_{cav}}{\underbrace{P_{cav} + P_{ext}}_{P_{tot}}} = \frac{Q_0}{1 + \beta}$$

The coupling fixes the reflection coefficient at input port, the resonance bandwidth and the ratio between the power dissipated into the cavity and external load.

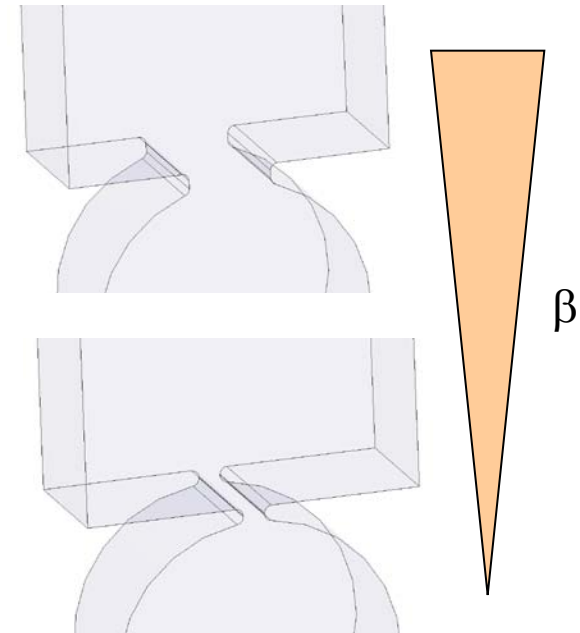

Coupling coefficient

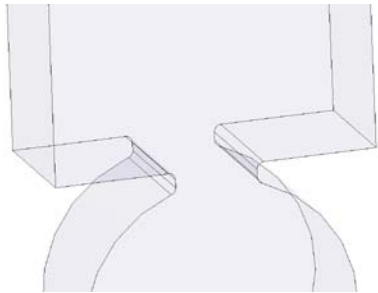

$\beta > 1$ over coupling

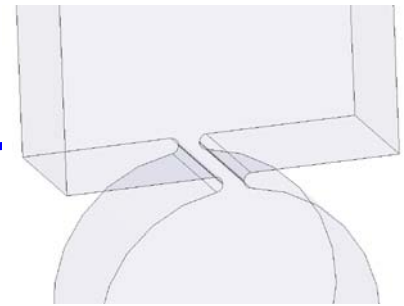
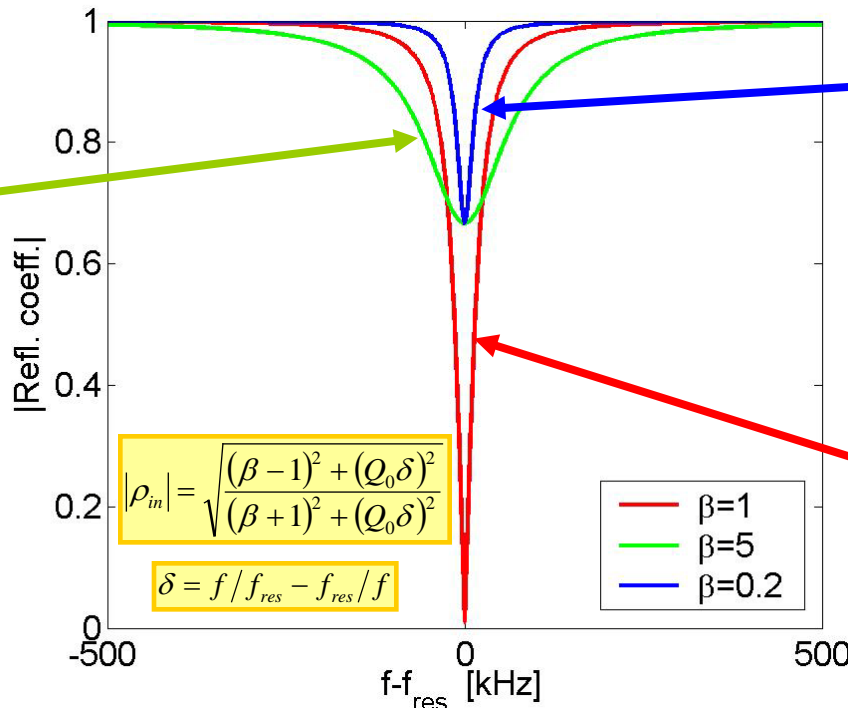

$\beta < 1$ under coupling

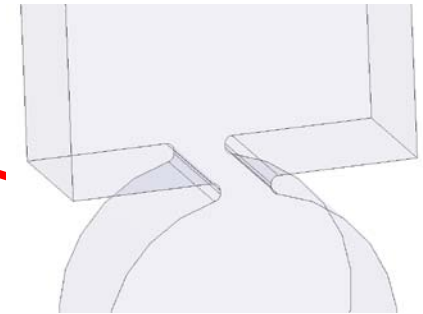

$\beta=1$ critical coupling

The choice of the coupling depends on the cavity operational condition with beam.

slot

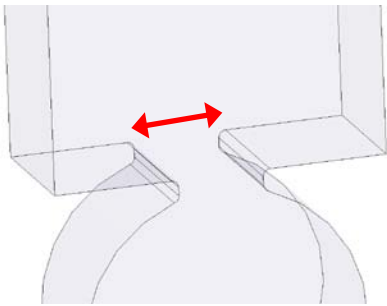

Longitudinal slot

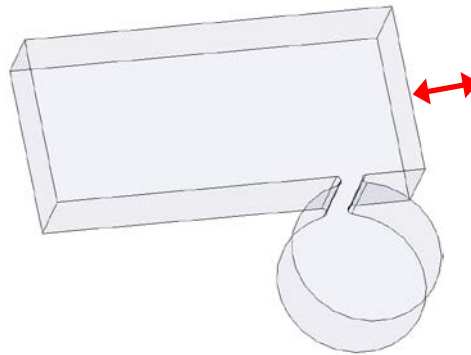

antenna

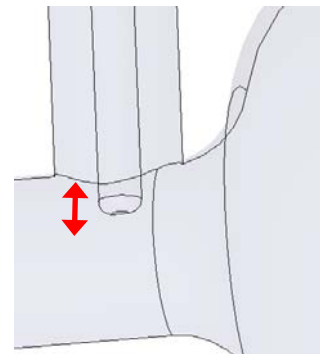

loop

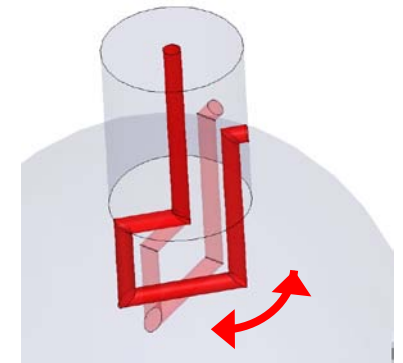

The coupling is fixed once we have constructed the cavity

It is possible to **change the coupling** changing the position of the short circuit plane, the antenna penetration or the loop orientation

Design/calculation of coupling coefficient

In the design of a coupler (by, as example, an electromagnetic code) it is important to calculate and tune the coupling coefficient. To calculate it is enough to:

- 1) **establish if we are under-coupled or over-coupled.** To do this it is sufficient to look at the reflection coefficient at the coupler input port (as a function of frequency) in the **complex plane**. Out of resonance the reflection coefficient has an absolute value equal to 1 and, therefore, it stay on a circle with radius equal to 1. At resonance it describes a circle towards the origin of the complex plane. It is easy to demonstrate that, if the circle include the origin of the complex plane we are over-coupled, if not we are under-coupled. If the circle cross the origin we are in critical coupling.
- 2) Once we have established if we are over- or under-coupled, **we can calculate the coupling by the formulae:**

$$\beta = \frac{1 + |\rho_{in}|}{1 - |\rho_{in}|} \quad (\text{overcoupled})$$

$$\beta = \frac{1 - |\rho_{in}|}{1 + |\rho_{in}|} \quad (\text{undercoupled})$$

$\beta < 1$ under coupling

$\beta > 1$ over coupling

$\beta = 1$ critical coupling

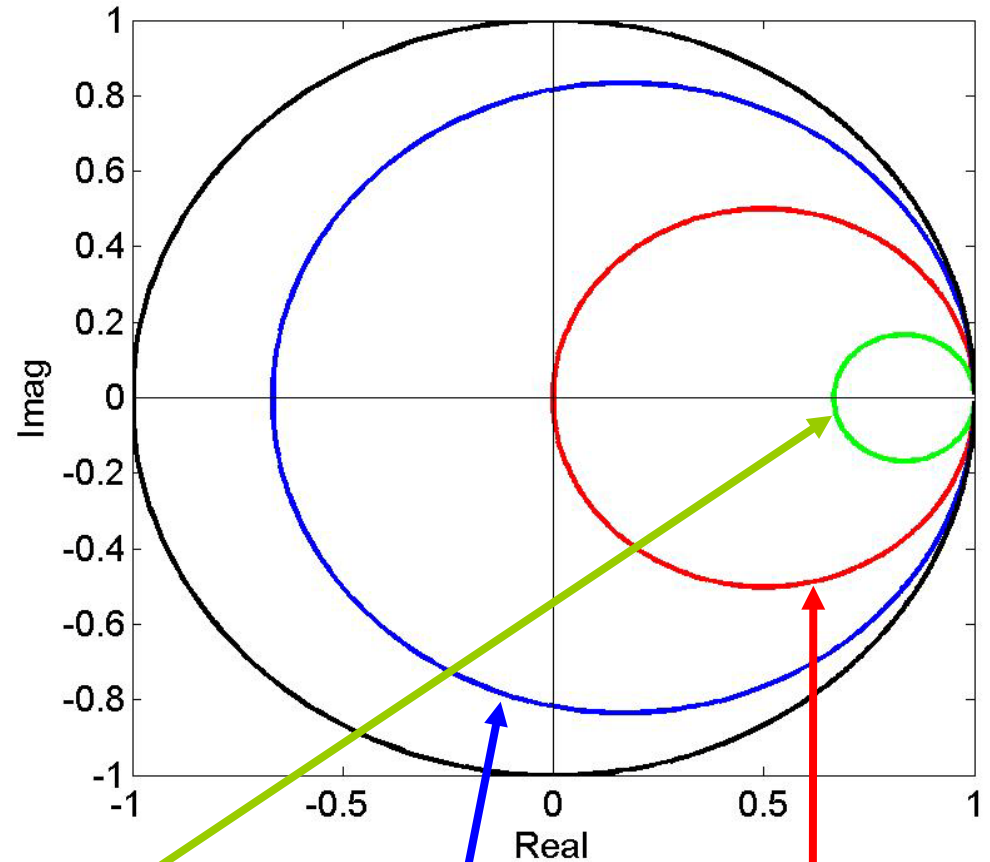

Where $|\rho_{in}|$ is the absolute value of the reflection coefficient at resonance

Waveguide couplers for NC SW cavities: RF guns

Normal Conducting **RF guns** are the **first stage of acceleration** of e^- in the LINACs for FEL. They are, in general, 2-3 cell SW accelerating structures operating on the π mode at frequencies of the order of few GHz. Required coupling coefficients β are between 1 and 2. Because of the high accelerating gradient (~ 50 - 100 MV/m), high input power (~ 10 MW) operation and fixed coupling, the structure are fed directly by waveguides and the **coupler is realized by one slot in the waveguide**.

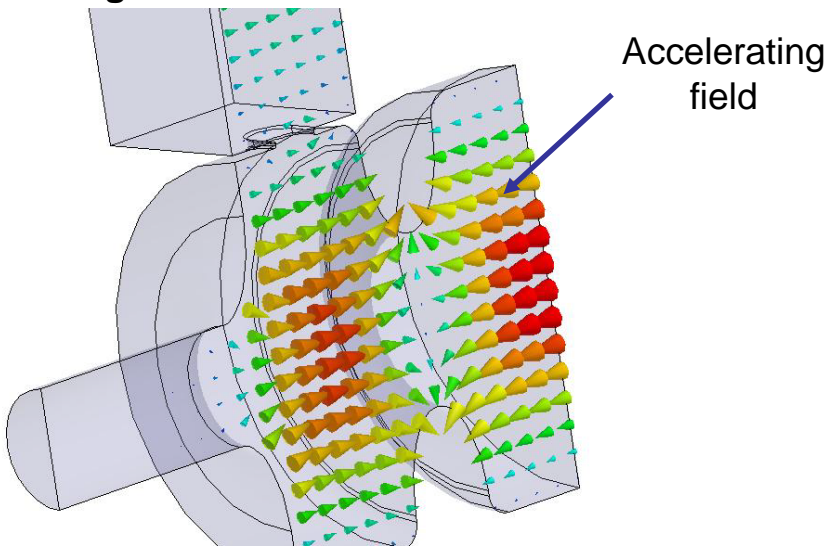

FIELD DISTORTION

Because of the relatively low energy of the electron beam (few MeV) the accelerating field has to have an excellent uniformity to preserve the beam quality. "Standard" coupling slots introduce a distortion in the field distribution and a **dipole and quadrupole component of the field** can appear strongly affecting the beam dynamics.

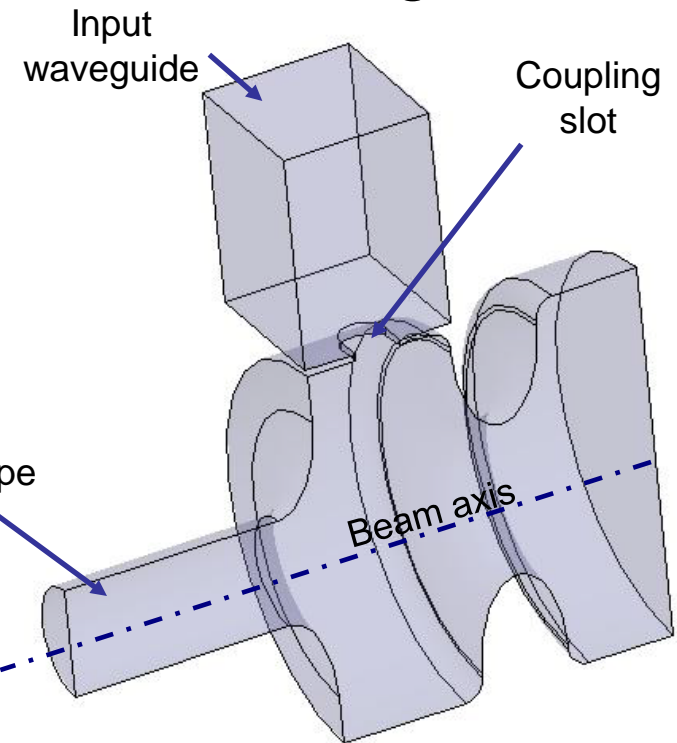

H field amplitude distribution

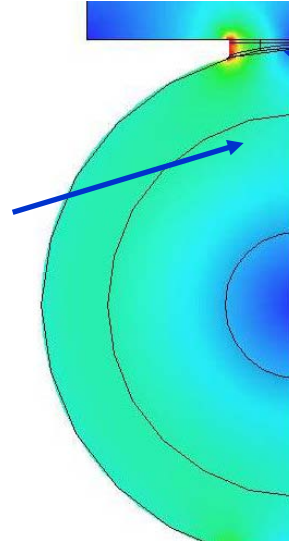

HIGH DISSIPATION IN THE SLOT

In the **slot region** there is an **high dissipation due to the high surface density currents** related to the high magnetic field. The high losses can create hot spots in the coupling region damaging of the coupler itself.

Compensation of the field distortions

DIPOLE COMPONENT

Ideal cavity

Beam axis

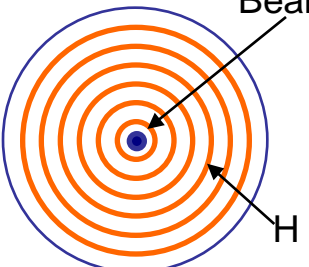

Cavity with coupler

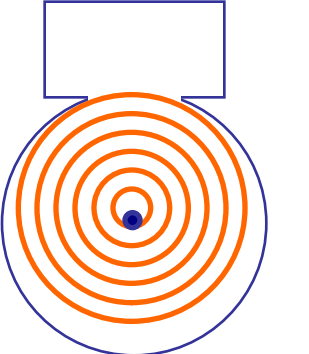

Compensating slot

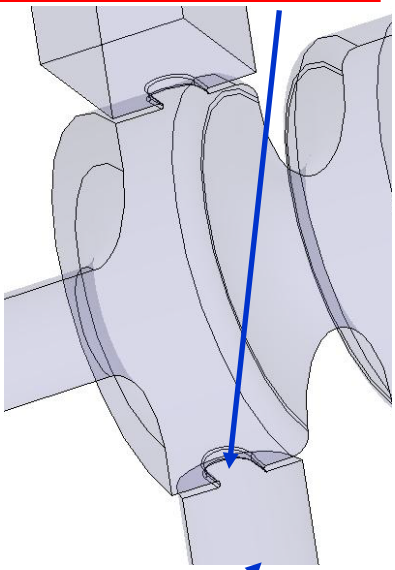

Used for pumping

Dual feed

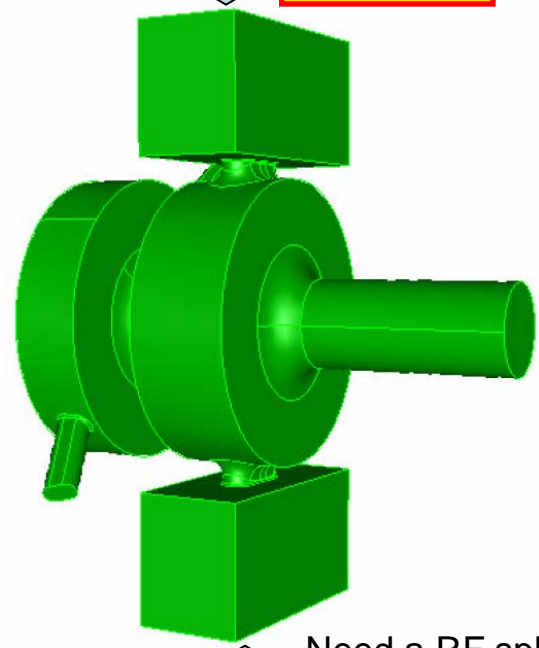

Need a RF splitter

QUADROPOLE COMPONENT

Racetrack profile

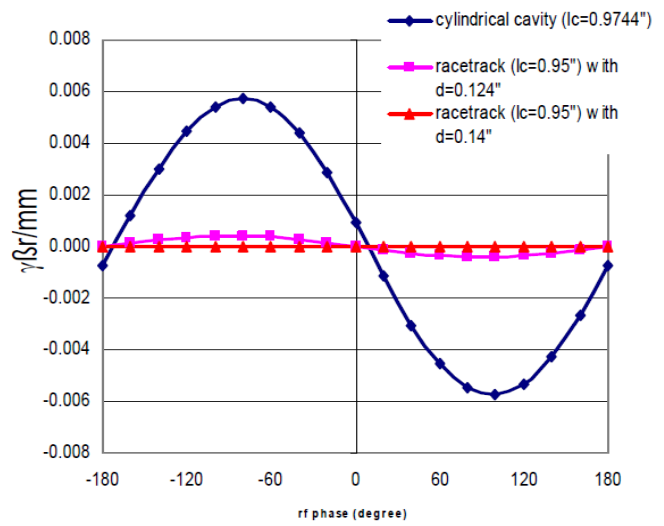
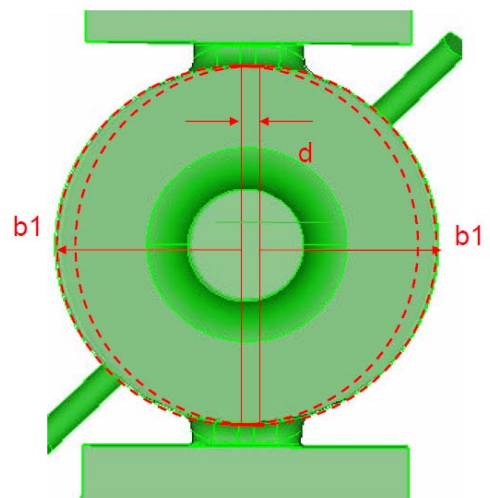
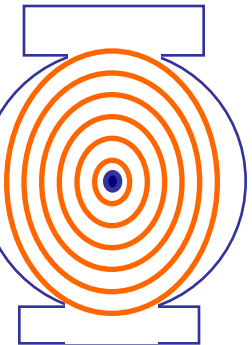

Pulsed heating in couplers

RF power enters the structure through the slots. The **rf surface currents flow along the edges of the slots** and, therefore, this edge, is a place where **local rf currents are significantly amplified**. The pulse temperature rise ΔT (*D.P. Pritzkau*) is given by:

If this pulsed heating exceed ~ 100 C one can have serious damages of the coupler itself.

Magnetic field
(calculated by e.m. codes)

$$\Delta T = \frac{|H_{\parallel}|^2 \sqrt{t}}{\sigma \delta \sqrt{\pi \rho' c_{\epsilon} k}}$$

$|H_{\parallel}|^2$: Magnetic field (calculated by e.m. codes)
 \sqrt{t} : RF pulse length
 σ : electrical conductivity
 δ : skin depth
 ρ' : material density
 c_{ϵ} : specific heat
 k : thermal conductivity

Reduction of the pulsed heating

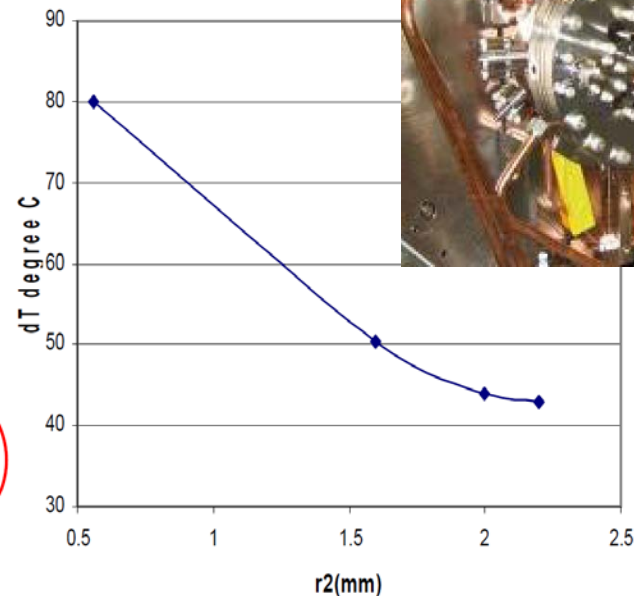
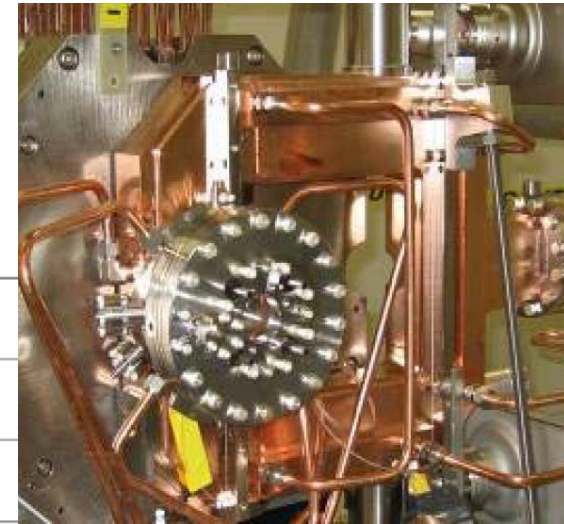
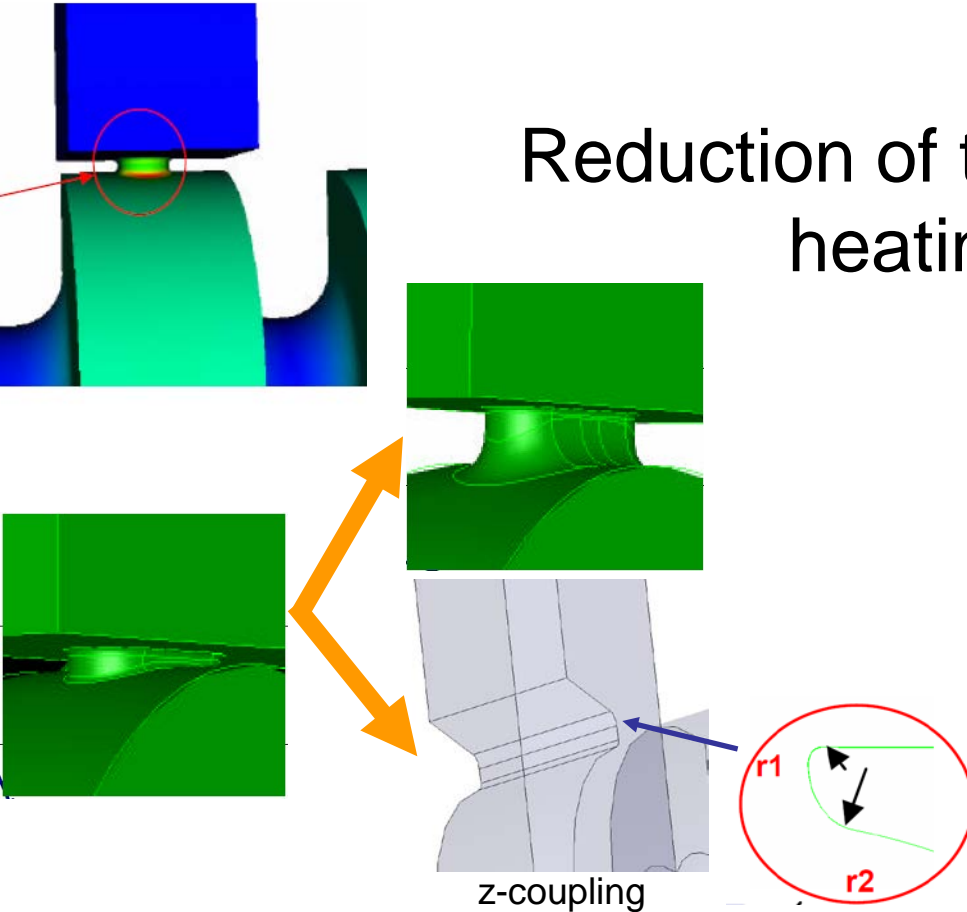

LCLS gun
 $f_{RF} = 2.856$ GHz
 $t = 3$ μ s
 $E_{acc} = 120$ MV/m
 Symmetric
 z-coupling

Coaxial power couplers for RF guns

In order to avoid emittance growth due to field asymmetries introduced by the coupler an alternative **idea is to use a coaxial input coupler** that couples to the cavity on the cavity axis (*F.B. Kiewiet, K. Flottmann,...*).

Asymmetric mode configurations are strongly suppressed since the symmetry of the cavity is not disturbed.

Dipole modes which can be generated at the Door-knob transition are in addition damped in the coaxial line.

This scheme also reduces the pulsed heating in the coupler region.

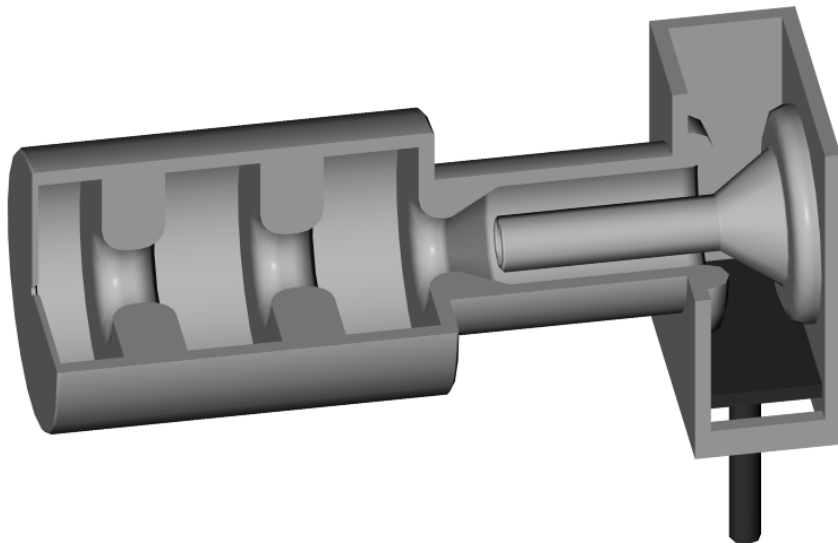
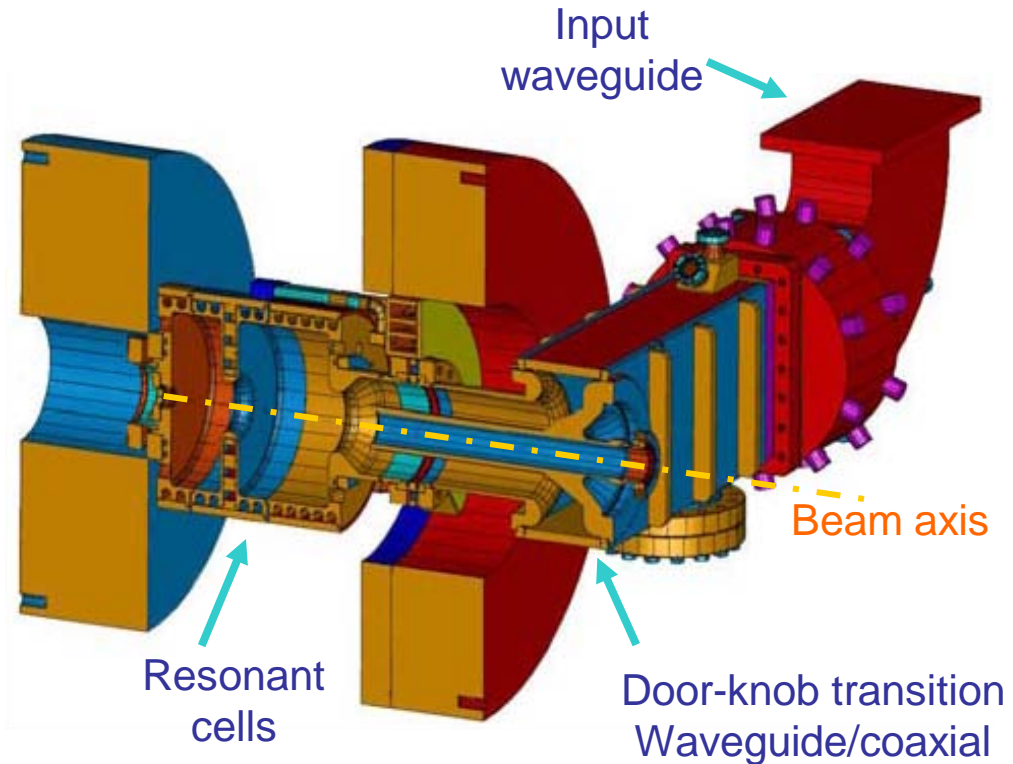

The guns of the Free Electron Laser in Hamburg (**FLASH**) and the Photoinjector Test Facility at DESY in Zeuthen (**PITZ**) are based on this principle.

RF parameters of the gun cavity

Input power	4.5 MW
Resonance frequency	1.3 GHz
Q value	21 500
Max. gradient on the cathode	50 MV/m
Max. energy gain for a particle starting with $\beta = 0$ on the cathode	5.6 MeV

Coaxial-loop couplers for SW NC cavities: DAΦNE cavity

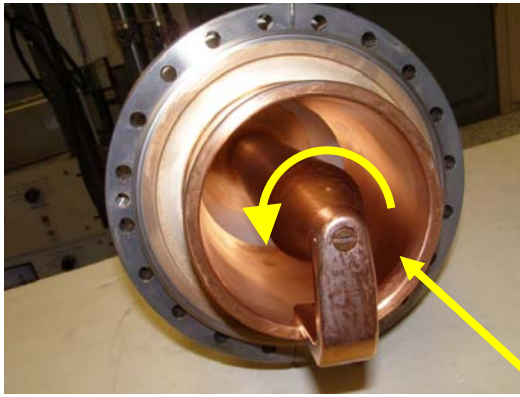

Max input power (CW)	100 kW
Frequency	368 MHz
Coupling β	0-10

The loop can be rotated changing the coupling from 0 to 10

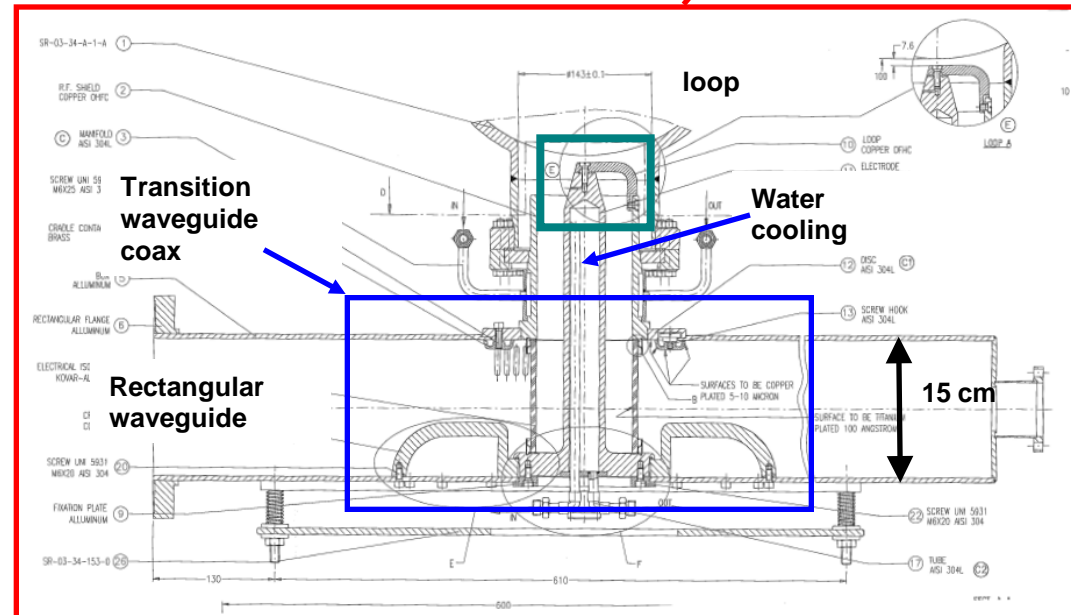
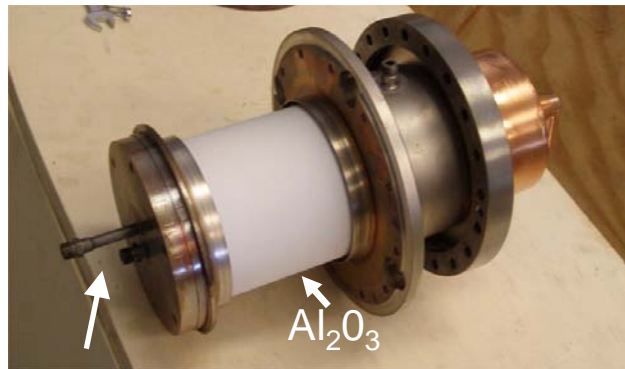
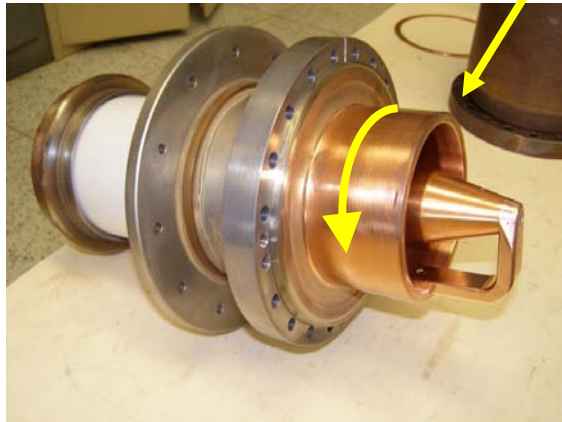
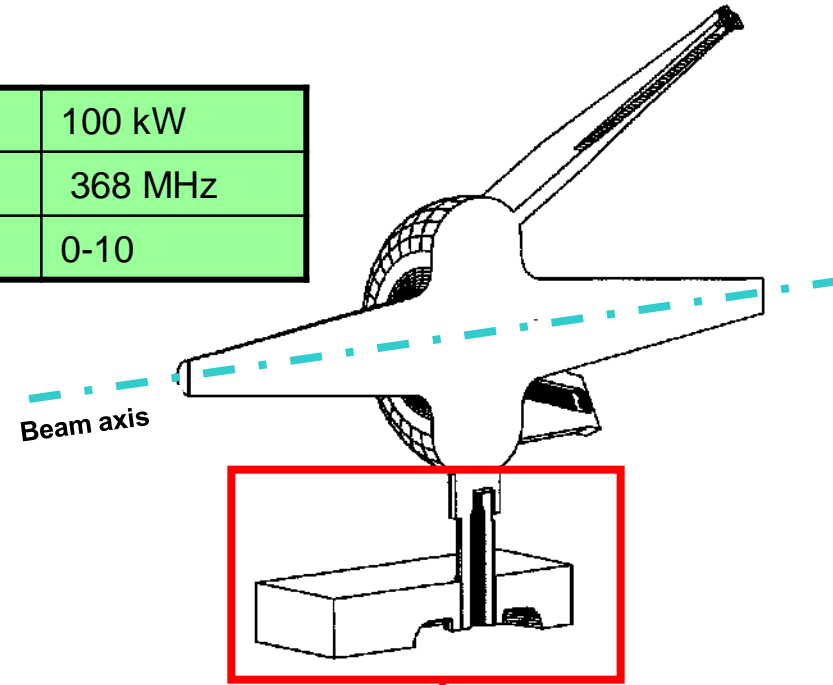

Couplers for Traveling Wave structures

Traveling wave structures are **normal conducting structures** used for electron acceleration. They have an input coupler, many accelerating cells (~80), and an output coupler.

Because of the high gradient (~20-40 MV/m) and high input power (~100 MW) **the structures are fed by waveguides**.

The coupler is realized, in this case, by a **slot in the waveguide** and the radius of the first accelerating cell (R_c) together with the slot aperture (w) are tuned to not have reflections at the waveguide input port. This coupler match the TE_{11} mode of the waveguide with the traveling wave mode (TM_{01} -like).

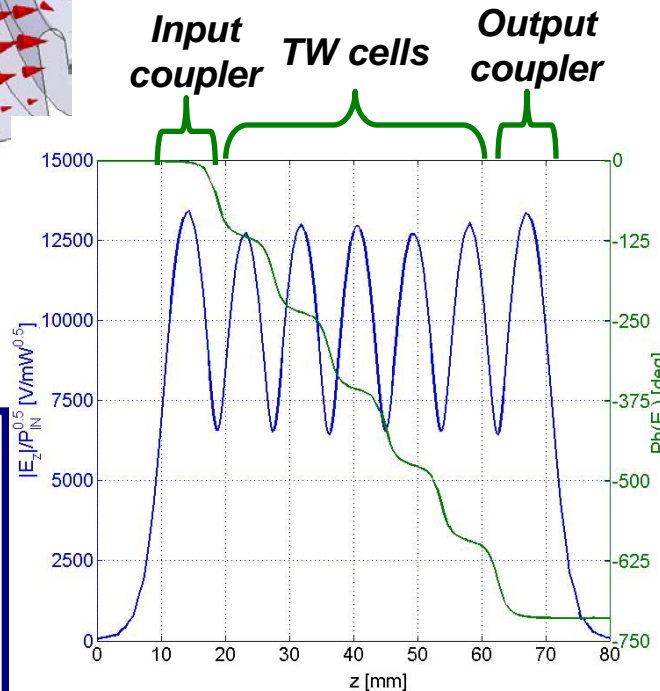
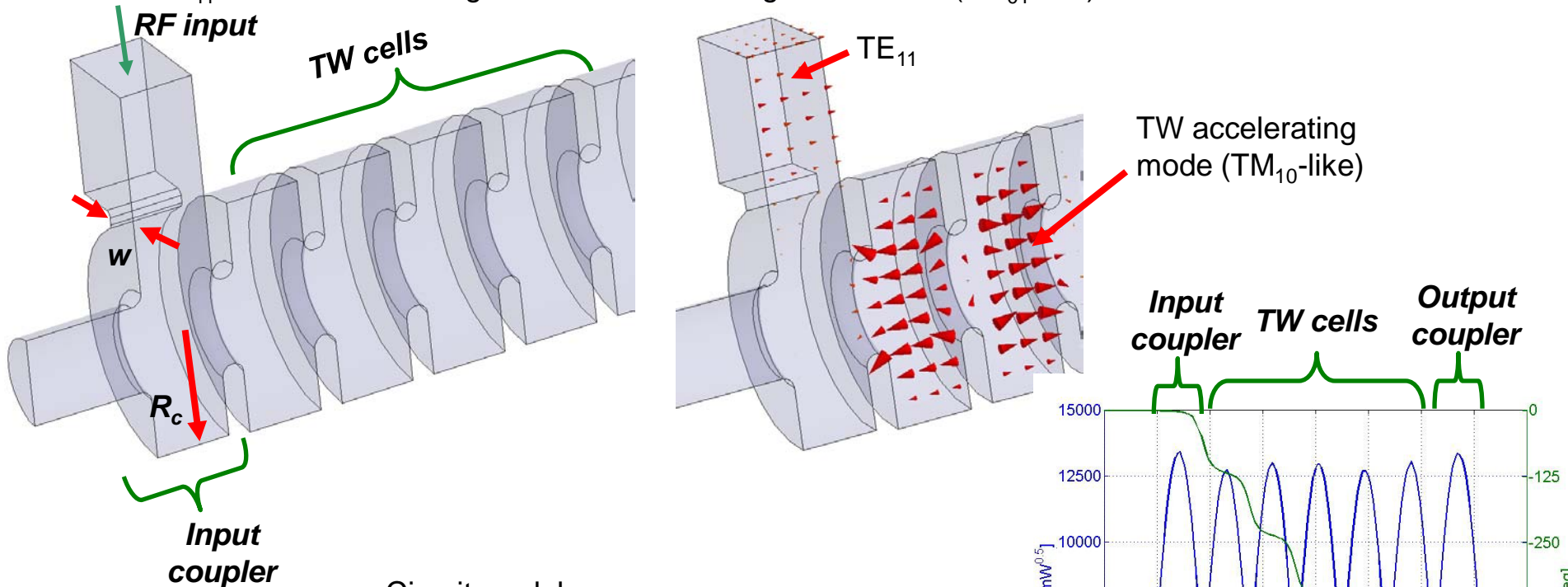

Circuit model

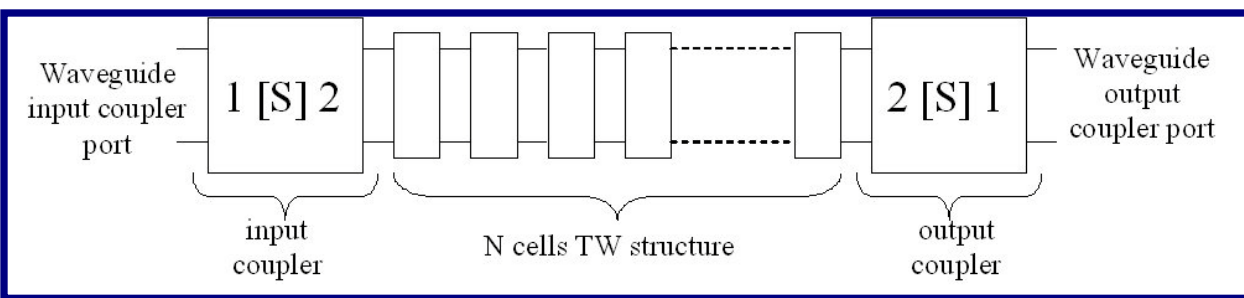

Field distortions introduced by the couplers in the coupler cell

In general the slots are large

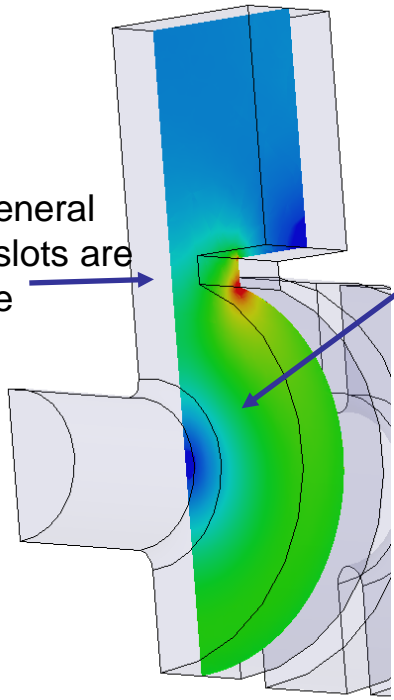

distortion in the field distribution: **dipole** and quadrupole components.

Compensation of the dipole field

There are several techniques to compensate the dipole component.

Transverse offset of the coupler
(does not give a total compensation of the the dipole kick)

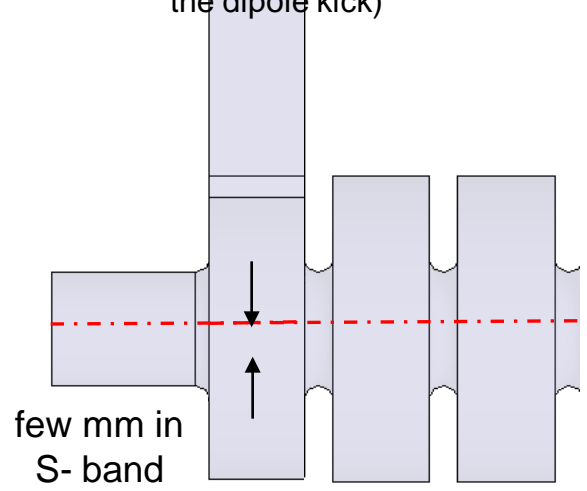

Dual feed
(it needs a splitter)

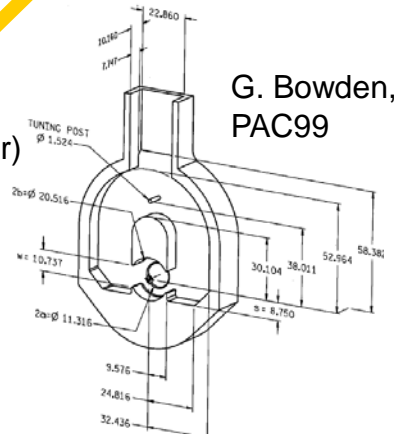
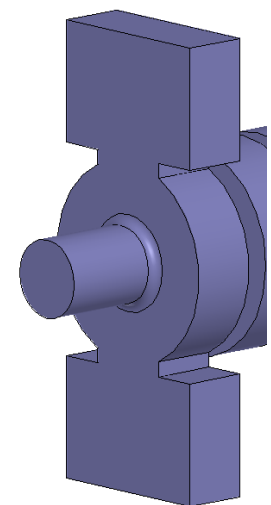

G. Bowden, PAC99

J-type coupler
(C. Suzuki, PAC 97)

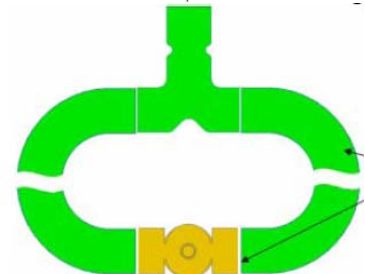
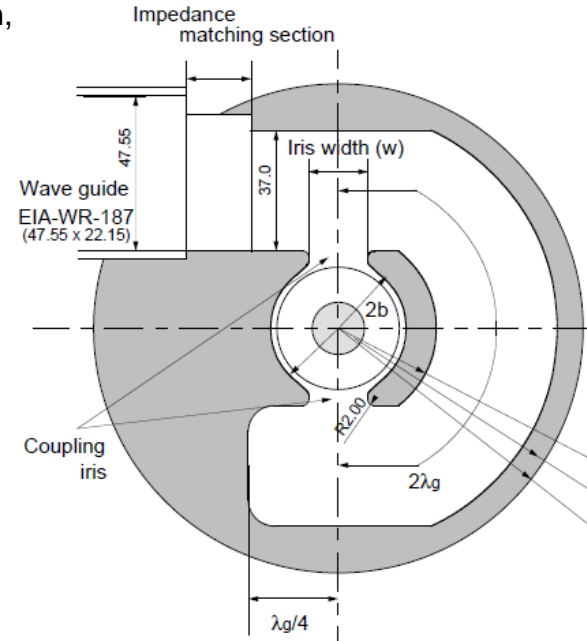

Couplers for high power-high gradient applications

In TW (or SW) **high gradient LINAC** (typically C/X-Band structures for linear collider) the magnetic field in the coupler region can reach very high values. This give a local pulsed heating (with $\Delta T > 100^\circ\text{C}$) that **can feed breakdown phenomena in the coupler itself**.

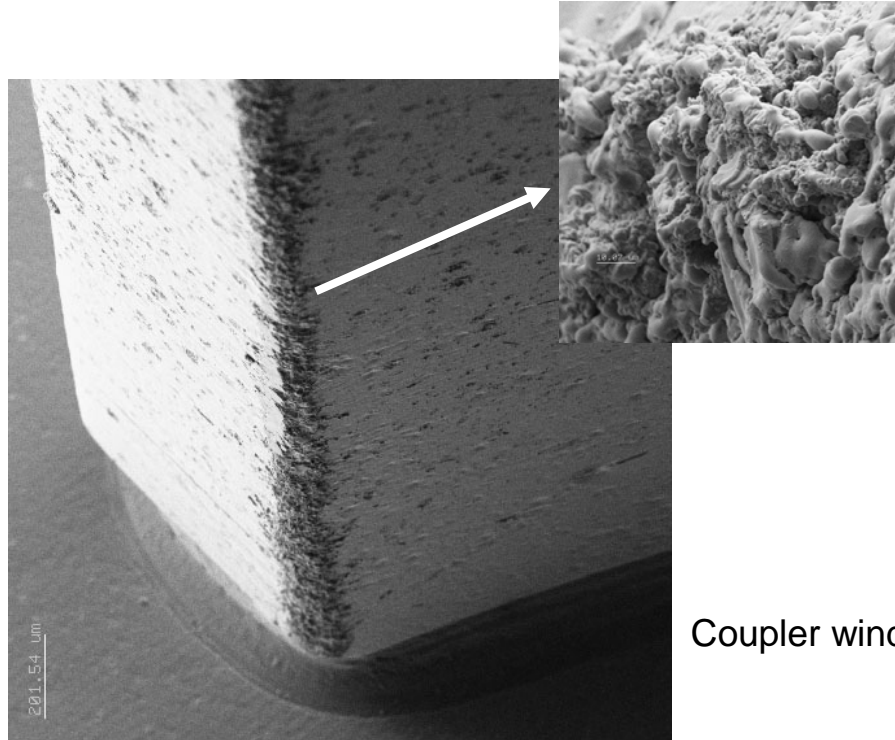
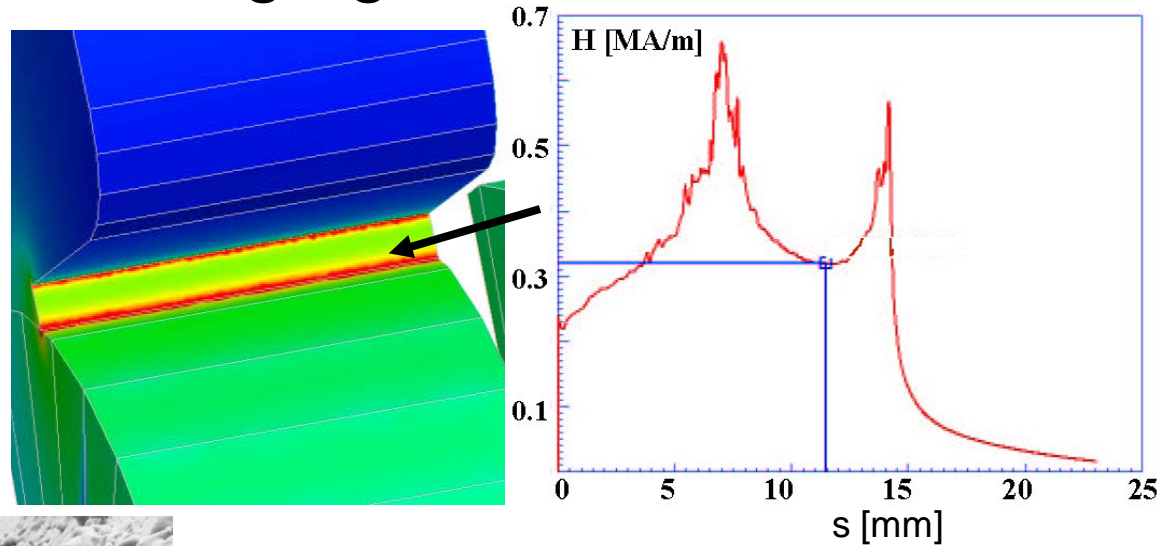

Coupler window

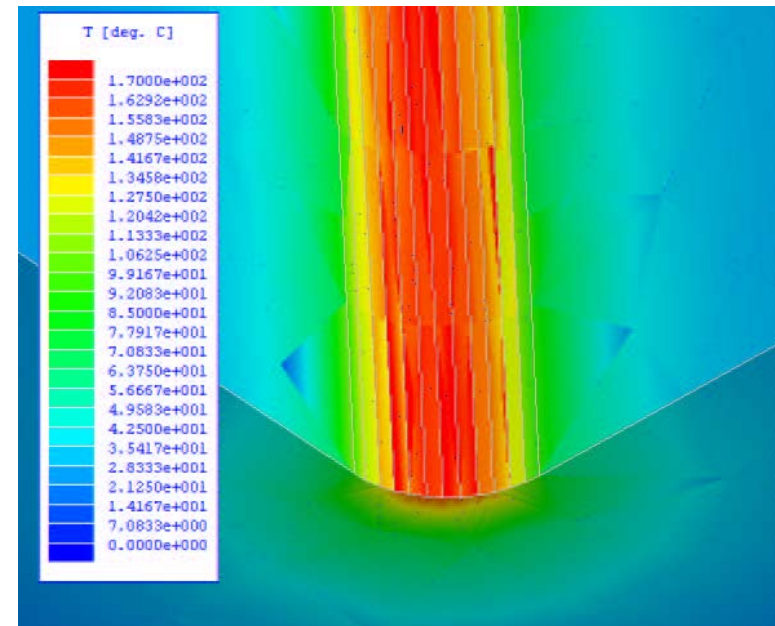

Surface temperature distribution
(400 ns pulse, 82.5 MW, maximum
temperature 166°C)

(courtesy V. Dolgashev)

Low field couplers for high gradient applications

Rounded couplers

The magnetic field can be reduced **increasing the radius of the coupling slot.**

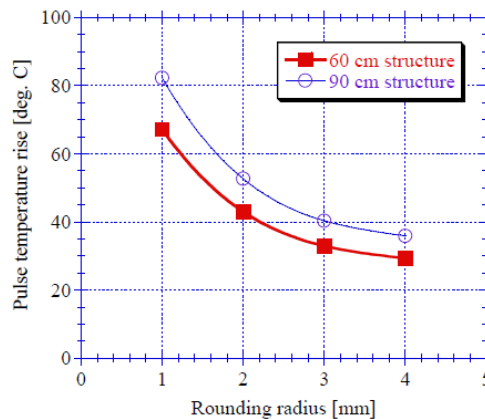
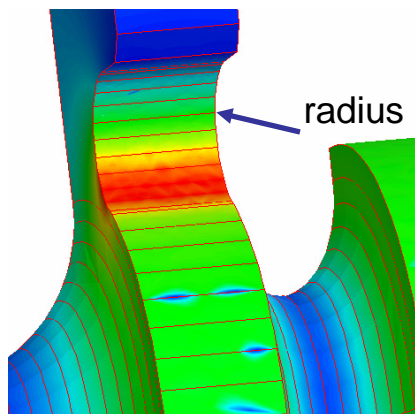

Mode-launcher coupler

The coupler is divided in two parts:

-the first one is a **mode converter** TE_{11} (rectangular) to TM_{01} (circular)

-the second one is a **matching coupler** between the TM_{01} mode of the circular waveguide and the TM_{01} -like accelerating mode

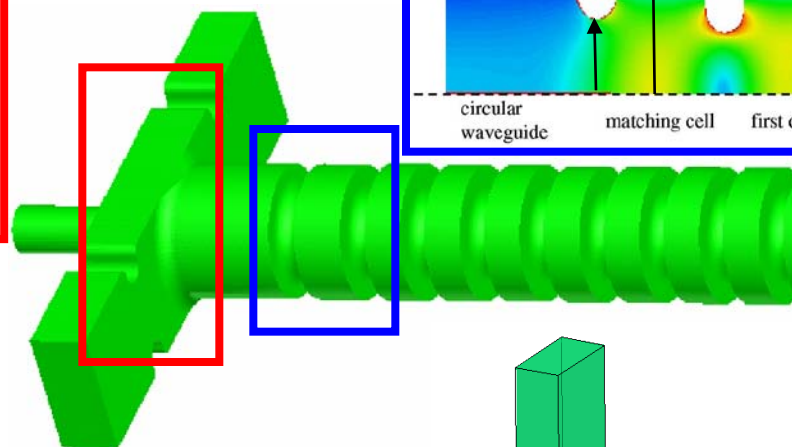
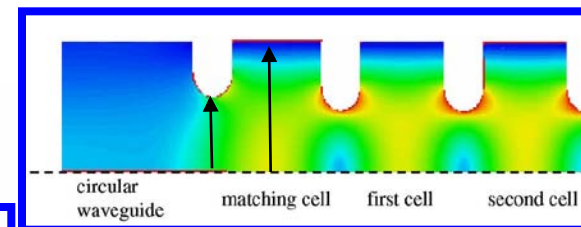
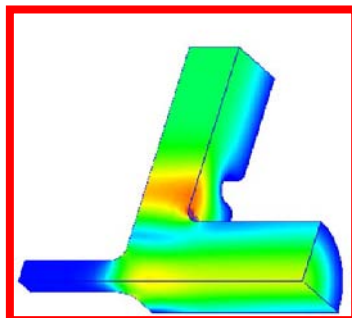

Waveguide coupler

Similar to the mode-launcher coupler but the mode converter and the matching cell are **compacted** in a single cell. In this case the integration of a splitter in a compact geometry is easier because of the dimensions of the coupler itself (C. Nantista, et al., PRST-AB, 2004)

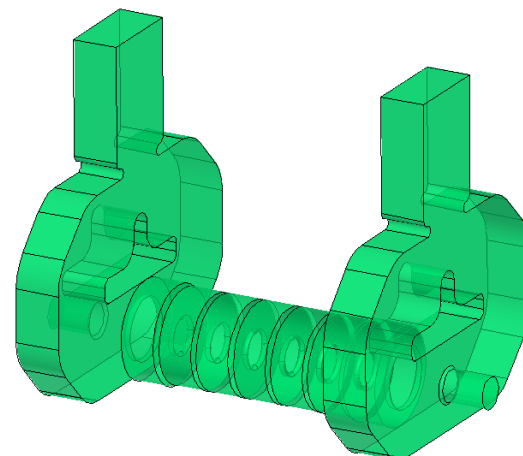
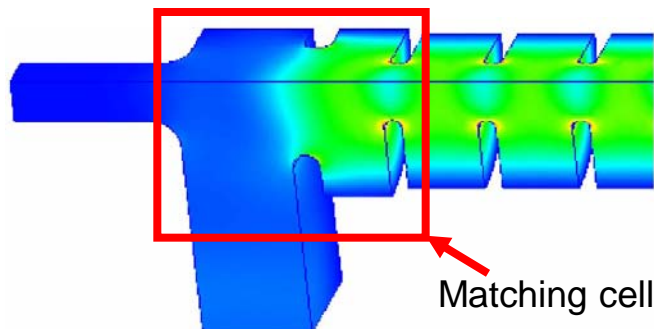

Couplers for superconducting cavities

Superconducting cavities \Rightarrow extremely low surface resistance (about $10 \text{ n}\Omega$ at 2 K).

Quality factors of normal conducting cavities are 10^4 - $10^5 \Rightarrow$ for sc cavities they may exceed 10^{10} ; only a tiny fraction of the incident rf power is dissipated in the cavity walls, most of it is either transferred to the beam or reflected into a load.

Belows for Q_{EXT} tunability. For many accelerators it is necessary to tune the coupling changing the penetration of the antenna in the pipe.

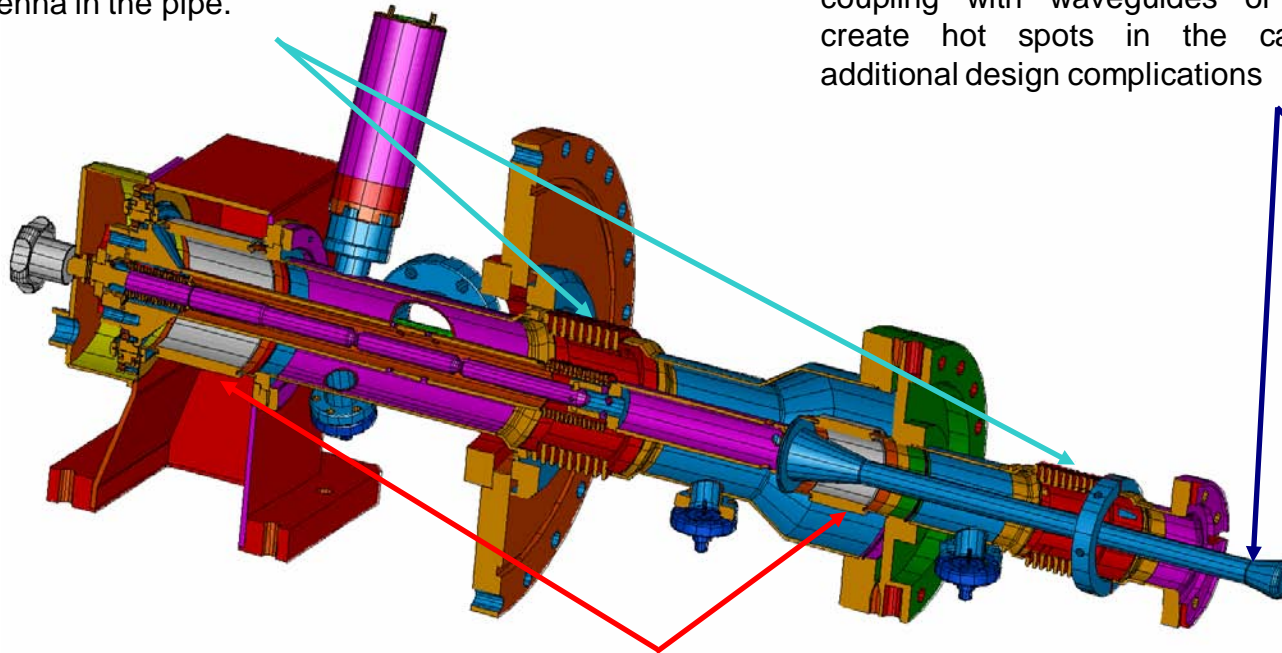

Coaxial-type electric couplers have the widest applications, because magnetic coupling with waveguides or loops can create hot spots in the cavities with additional design complications

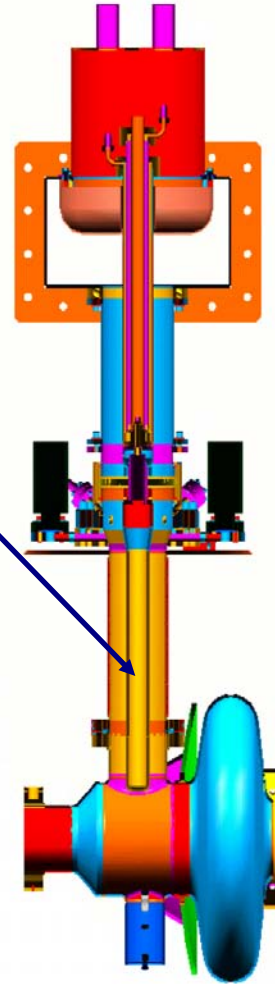

Vacuum barriers (windows). They prevent contamination of the SC structure. Obviously these barrier are necessary also in normal conducting accelerators but the demand on the quality of the vacuum and reliability of the windows are less stringent. The failure of a window in superconducting accelerator can necessitate very costly and lengthy in repair. They are made, in general, in Al_2O_3 . Ceramic material have a high Secondary Emission Yield (SEY) that stimulates the multipacting activity. Ti-coating can reduce this phenomena. To reduce the risk of contamination two RF windows, warm and cold, are advisable.

Thermal barrier: The RF power must be fed into the cold superconducting cavity and in the coupler we cross the boundary between the room temperature and the low-temperature environment (usually 2 - 4.5 K).

Example of couplers for superconducting cavities: TESLA

As an example of superconducting cavities we consider the TESLA Test Facility (TTF) cavities. The TTF cavity is a 9-cell standing wave structure of about 1 m length whose lowest TM mode resonates at 1300 MHz. The cavity is made from solid niobium and is cooled by superfluid helium at 2 K.

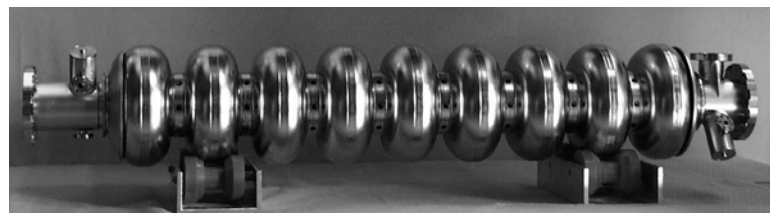

Each 9-cell cavity is equipped with its own titanium helium tank, a tuning system driven by a stepping motor, a coaxial rf power coupler capable of transmitting more than 200 kW, a pickup probe, and two higher-order mode (HOM) couplers.

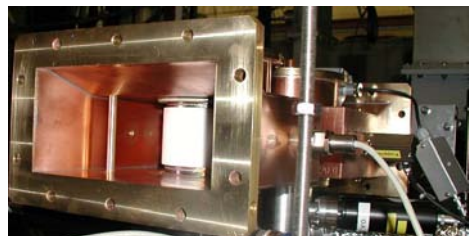

waveguide to coax transition

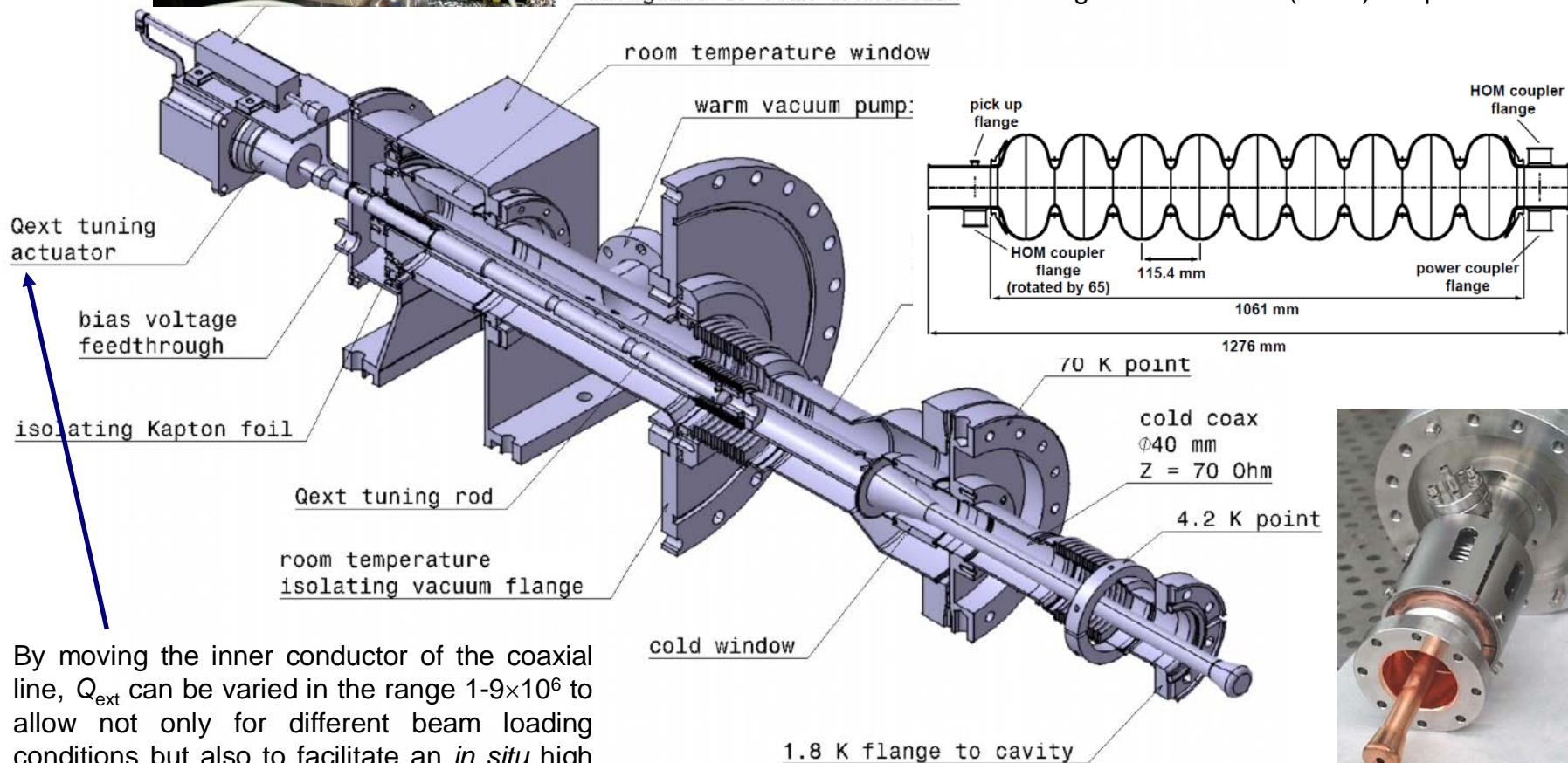

By moving the inner conductor of the coaxial line, Q_{ext} can be varied in the range $1-9 \times 10^6$ to allow not only for different beam loading conditions but also to facilitate an *in situ* high power processing of the cavities.

Other aspects of couplers for superconducting cavities

Q_{ext} tuning

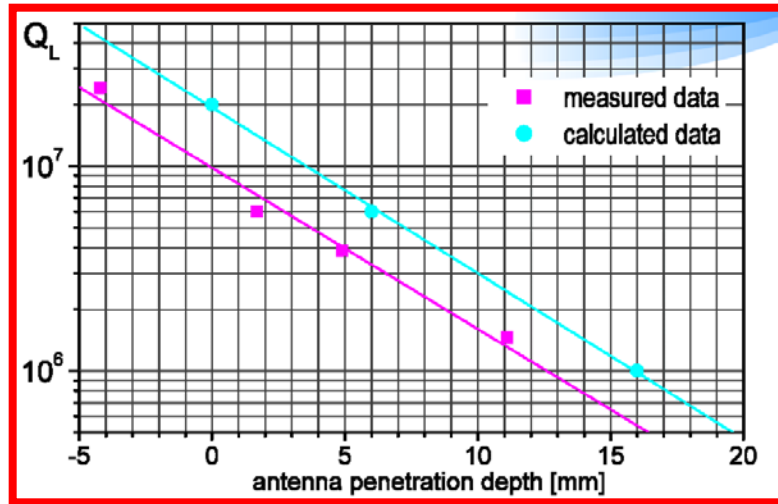

CW couplers

For CW couplers the high requirements in average power are demanding for the design of a cooling system. Usually the central antenna and the bellows can be water, gas or air cooled. Attention must also be paid to the thermal characteristics of the gaskets if the flange region proves to be a "hot zone". For certain materials (like Aluminium for example) it is possible to have vacuum leaks starting from ~ 150 degrees. In this case copper gaskets are recommended.

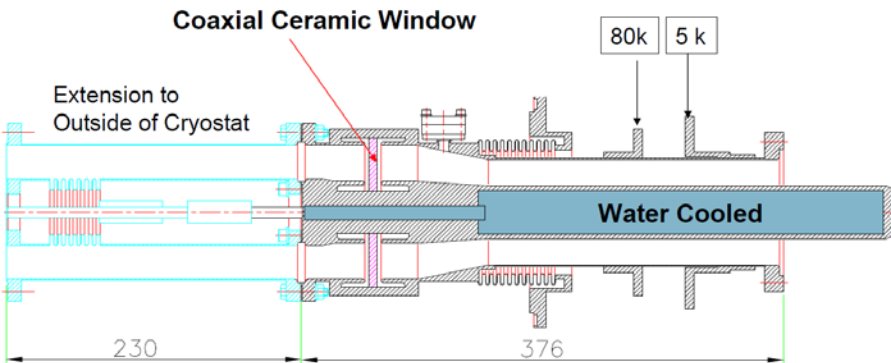

Ceramic Windows geometries

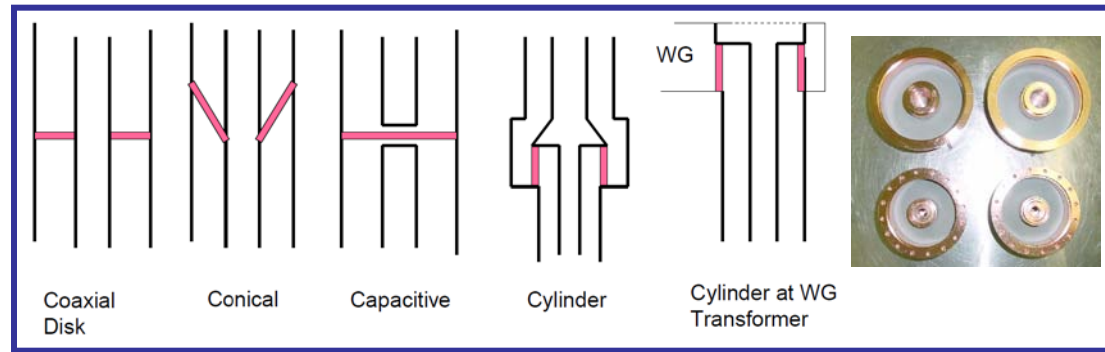

Beam dynamics

Another important parameter associated with the particle beam in the coupler design is the transverse kick.

The coupler insertion being asymmetric with respect to the cavity axis, a dipolar electric field component appears to have the effect of a beam kick in the transverse plane. This can be evaluated by integrating the equation of motion taking into account the simulated electromagnetic field on the beam axis. The remedy is to compensate this effect by alternating the coupler insertion on both sides of the beam propagation axis and, in the design phase, reducing the ratio between the coupler and the cavity diameter.

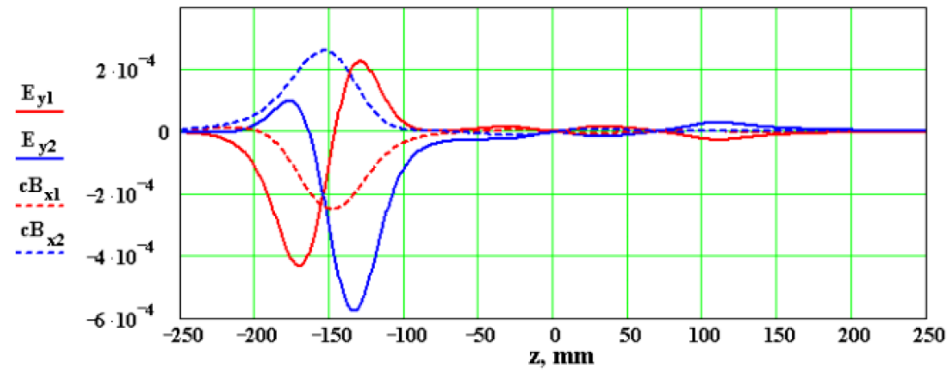

Multipacting in High Power Couplers

Multipacting is a phenomenon of **resonant electron multiplication**. **Electrons are emitted** from the walls because of the presence of high electric field. At a specific level of input power (field) the electrons can be accelerated, can hit another wall (or the same wall) and force the emission of more electrons (if the Secondary Emission Yield-SEY is bigger than 1). Therefore a **large number of electrons can build up an electron avalanche**, leading to remarkable **power losses and heating of the walls**, so that it becomes impossible to increase the cavity fields by rising the incident power.

Multipacting electrons can strongly affect the electromagnetic design since the low order power thresholds must be carefully assessed to avoid sparks and coupler damage already during the conditioning process at some specific levels of input power.

The **multipactor threshold** varies following a $(f D)^4$ or a $Z D^4$ laws where f is the frequency, Z is the coaxial impedance D external diameter of the coaxial coupler. This formulae can also help in designing the coupler.

Multipacting is strongly enhanced in couplers by the presence of the **ceramic windows** that usually present a **high SEY** and of **bellows with very high field zones**.

Shifting of the resonant condition can be achieved by applying a **bias voltage on the central antenna in the coaxial couplers**. In the **waveguide** option the same effect is obtained by applying a **magnetic field**.

Concerning the ceramic emission, a **coating** (of some tenths of nm) with a low SEY material (usually Ti or TiN) is mandatory.

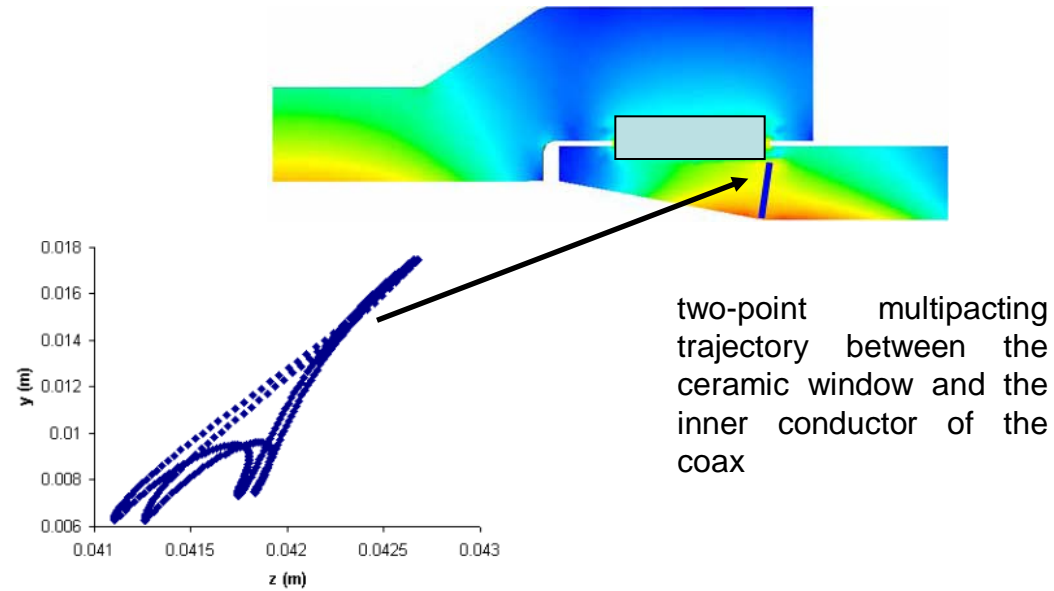

Example of coupler for superconducting structures (CW)

CW input couplers

Facility	Frequency	Coupler type	RF window	Q_{ext}	Max. power
LEP2 / SOLEIL	352 MHz	Coax fixed	Cylindrical	$2 \times 10^6 / 1 \times 10^5$	Test: 565 kW 380 kW Oper: 150 kW
LHC	400 MHz	Coax variable (60 mm stroke)	Cylindrical	2×10^4 to 3.5×10^5	Test: 500 kW 300 kW
HERA	500 MHz	Coax fixed	Cylindrical	1.3×10^5	Test: 300 kW Oper: 65 kW
CESR (Beam test)	500 MHz	WG fixed	WG, 3 disks	2×10^5	Test: 250 kW 125 kW Oper: 155 kW
CESR / 3rd generation light sources	500 MHz	WG fixed	WG disk	2×10^5 nominal	Test: 450 kW Oper: 300 kW 360 kW
TRISTAN / KEKB / BEPC-II	509 MHz	Coax fixed	Disk, coax	$1 \times 10^6 /$ $7 \times 10^4 / 1.7 \times 10^5$	Test: 800 kW 300 kW Oper: 400 kW
APT	700 MHz	Coax variable (± 5 mm stroke)	Disk, coax	2×10^5 to 6×10^5	Test: 1 MW 850 kW
Cornell ERL injector	1300 MHz	Coax variable (15 mm stroke)	Cylindrical (cold and warm)	9×10^4 to 8×10^5	Test: 61 kW
JLAB FEL	1500 MHz	WG fixed	WG planar	2×10^6	Test: 50 kW Oper: 35 kW

Example of coupler for superconducting structures (Pulsed)

Pulsed input couplers

Facility	Frequency	Coupler type	RF window	Q_{ext}	Max. power	Pulse length & rep. rate
SNS	805 MHz	Coax fixed	Disk, coax	7×10^5	Test: 2 MW Oper: 550 kW	1.3 msec, 60 Hz 1.3 msec, 60 Hz
J-PARC	972 MHz	Coax fixed	Disk, coax	5×10^5	Test: 2.2 MW 370 kW	0.6 msec, 25 Hz 3.0 msec, 25 Hz
FLASH	1300 MHz	Coax variable (FNAL)	Conical (cold), WG planar (warm)	1×10^6 to 1×10^7	Test: 250 kW Oper: 250 kW	1.3 msec, 10 Hz 1.3 msec, 10 Hz
FLASH	1300 MHz	Coax variable (TTF-II)	Cylindrical (cold), WG planar (warm)	1×10^6 to 1×10^7	Test: 1 MW Oper: 250 kW	1.3 msec, 10 Hz 1.3 msec, 10 Hz
FLASH / XFEL/ ILC	1300 MHz	Coax variable (TTF-III)	Cylindrical (cold and warm)	1×10^6 to 1×10^7	Test: 1.5 MW 1 MW Oper: 250 kW	1.3 msec, 2 Hz 1.3 msec, 10 Hz 1.3 msec, 10 Hz
KEK STF	1300 MHz	Coax fixed (baseline ILC cavity)	Disks, coax (cold and warm)	2×10^6	Test: 1.9 MW 1 MW	10 μ sec, 5 Hz 1.5 msec, 5 Hz
KEK STF	1300 MHz	Coax fixed (low loss ILC cavity)	Disk (cold), cylindrical (warm)	2×10^6	Test: 2 MW 1 MW	1.5 msec, 3 Hz 1.5 msec, 5 Hz

Summary waveguide/coaxial couplers

Parameter	Waveguide	Coaxial	Notes
<i>Dimensions</i>	larger	Smaller	At low frequencies the coaxial are preferred
<i>Power handling capacity</i>	Higher	Lower	At high frequency and for high gradient/power structures the waveguide couplers are preferred
<i>Attenuation</i>	lower	higher	
<i>Vacuum/ pumping speed</i>	better	worst	
<i>Variable coupling</i>	Difficult to realize	Easy to make it	
<i>Cooling</i>	better	worst (inner)	

Design techniques for input couplers of TW structure (1/2)

Coupler design is performed using **3D electromagnetic codes**.

The coupler cell dimensions have to be designed in order to minimize the reflected power at the waveguide input/output ports.

Technique 1

Since, with e.m codes, it is not possible to consider an infinite number of TW cells, to design the single couplers we have to consider a **TW structure with input and output couplers and a few cells**. In this case it is possible to design the couplers by changing their dimensions minimizing the reflection coefficient at the waveguide input port and verifying that also the phase advance per cell in the TW structure is constant and equal to the nominal one. This procedure is, in general, very time consuming.

Technique 2

It is based on the following theorem:

$$S_{11} = 0 \Leftrightarrow \frac{\Gamma_s(n+2)}{\Gamma_s(n+1)} = \frac{\Gamma_s(n+1)}{\Gamma_s(n)} = e^{-j2\phi} \quad (\text{with } |\Gamma_s(n)| = 1)$$

S_{11} is the first element of the coupler scattering matrix

$\Gamma_s(n)$ is the reflection coefficient at the coupler waveguide when the structure is short circuited (n is the position of the short circuited cell)

$-\phi$ is the phase advance per cell in the TW structure

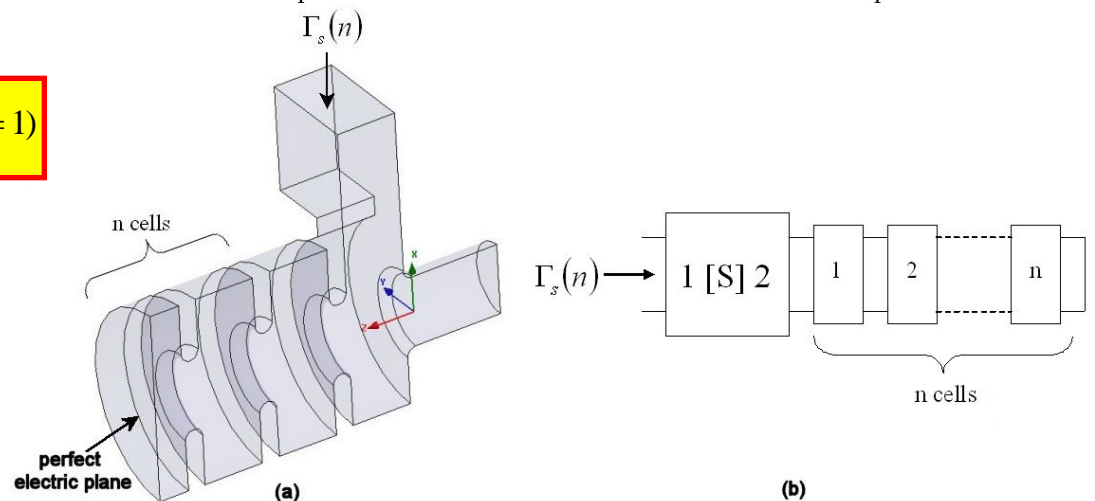
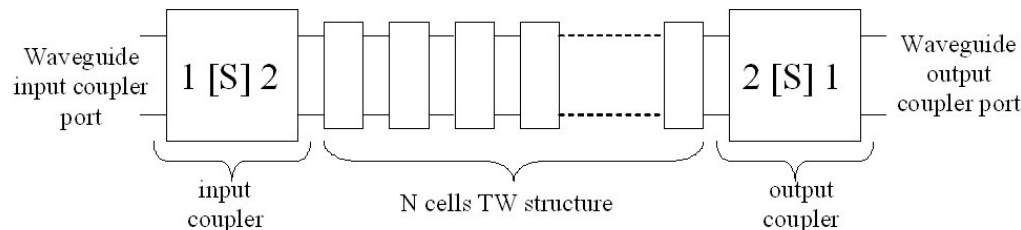
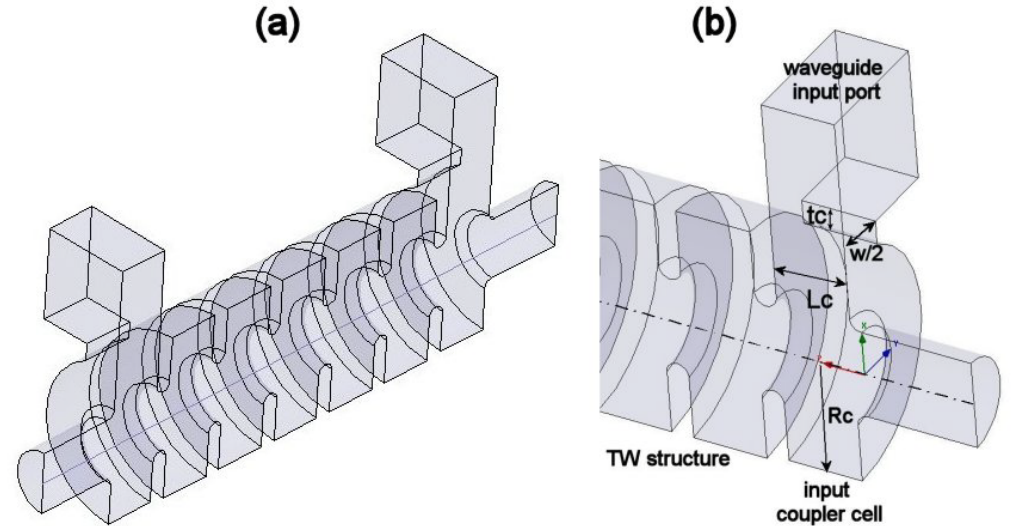

Design techniques for input couplers of TW structure (2/2)

If we consider the three cases to $n=0$, $n=1$ and $n=2$, the $|S_{11}|$ is given by:

$$|S_{11}| \cong \frac{1}{2(\sin \phi)^2} \sqrt{\frac{(\mathcal{G}_{21} + \mathcal{G}_{10})^2}{4(\cos \phi)^2} + \mathcal{G}_{10}^2 - \mathcal{G}_{10}(\mathcal{G}_{21} + \mathcal{G}_{10})}$$

where:

$$\mathcal{G}_{10} = \frac{\angle \left[\frac{\Gamma_s(1)}{\Gamma_s(0)} \right]}{2} + \phi$$

$$\mathcal{G}_{21} = \frac{\angle \left[\frac{\Gamma_s(2)}{\Gamma_s(1)} \right]}{2} + \phi$$

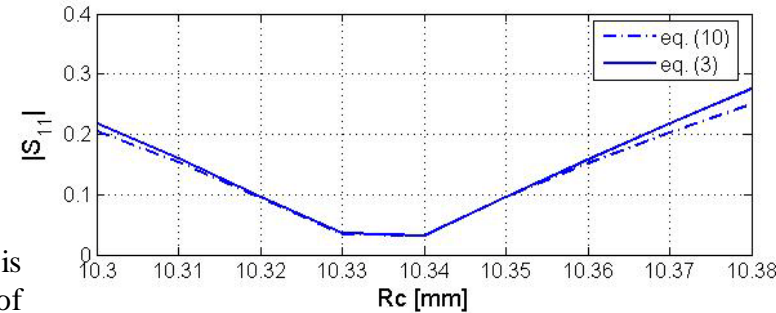
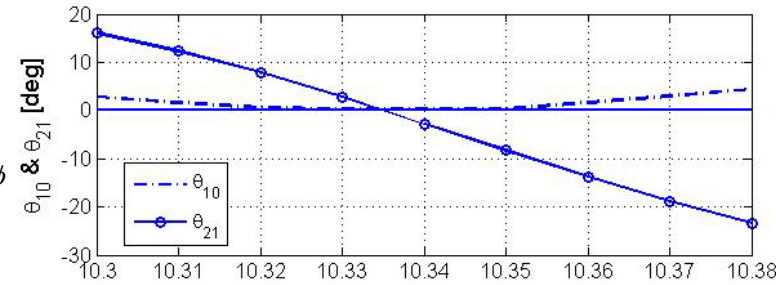
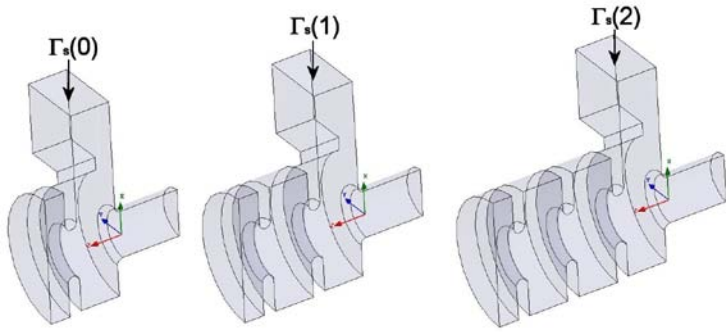

Reflection coefficient at the coupler waveguide as a function of frequency in the case of a 7 cell structure

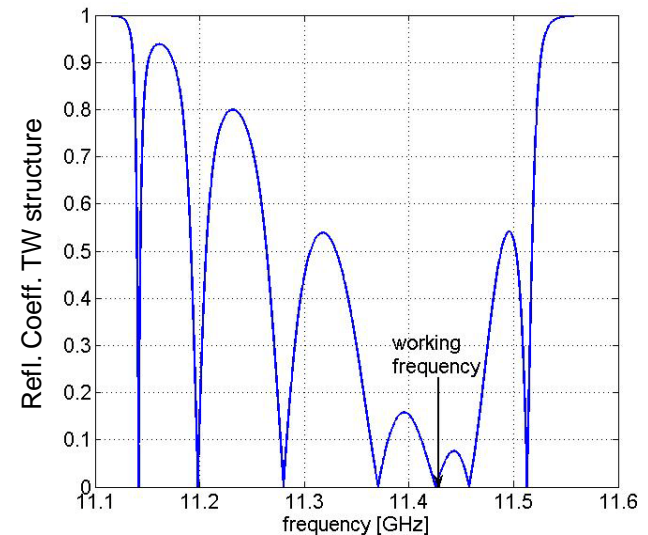

Calculated amplitude of the S_{11} element of the coupler scattering matrix as a function of frequency

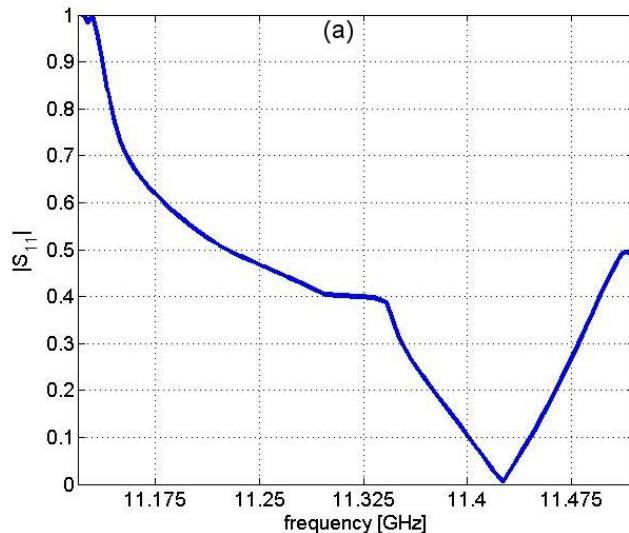

To tune the coupler it is enough to vary only two of the input coupler dimensions (two parameters) until the residual $|S_{11}|$ value is within the specified range. By simulations it is possible to show that the most sensitive parameters are w and Rc while the length Lc and the thickness tc can be kept fixed.

HFSS Examples

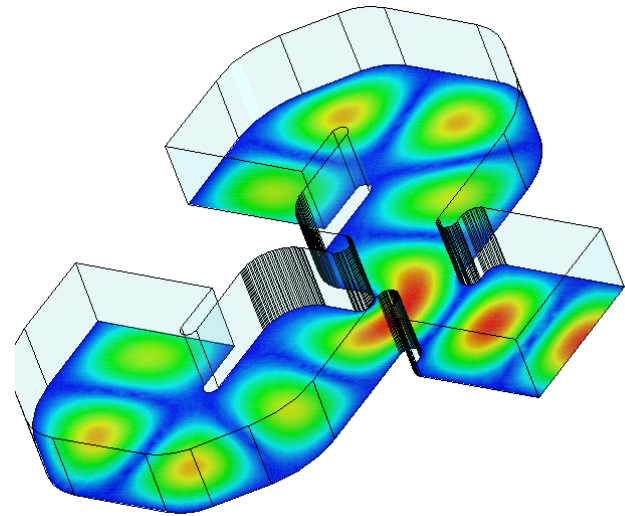
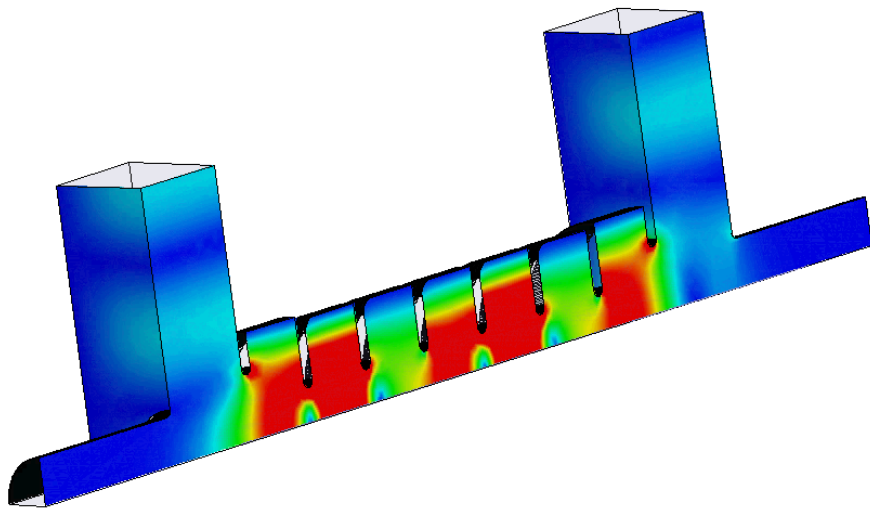

Splitter for symmetric feed

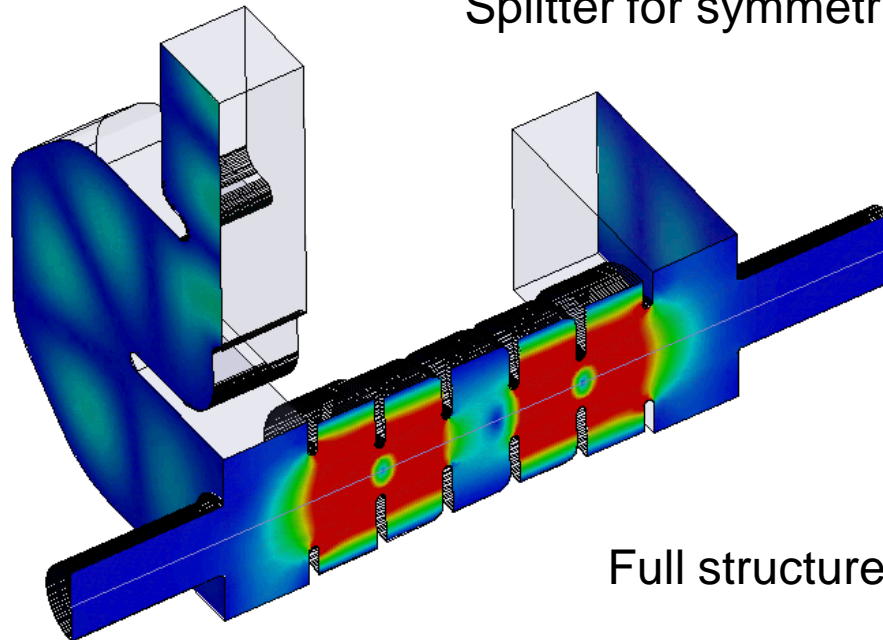

Full structure

Design techniques for input couplers of NC SW structures

In this case one has to design the **coupling slot in order to obtain the desired coupling coefficient without modifying the accelerating field distribution and the resonant frequency of the structure.**

The insertion of the waveguide input coupler, in fact, **detune the coupler cell** because it increases its volume.

This **gives a shift of the resonant frequency** of the working mode and detune of the field flatness with respect to the structure without input coupler.

To retune the coupler one has to tune (reduce) the radius of the cell itself. It is not possible to evaluate the coupling coefficient before the retuning of the coupling cell since it depends on the field level into the structure.

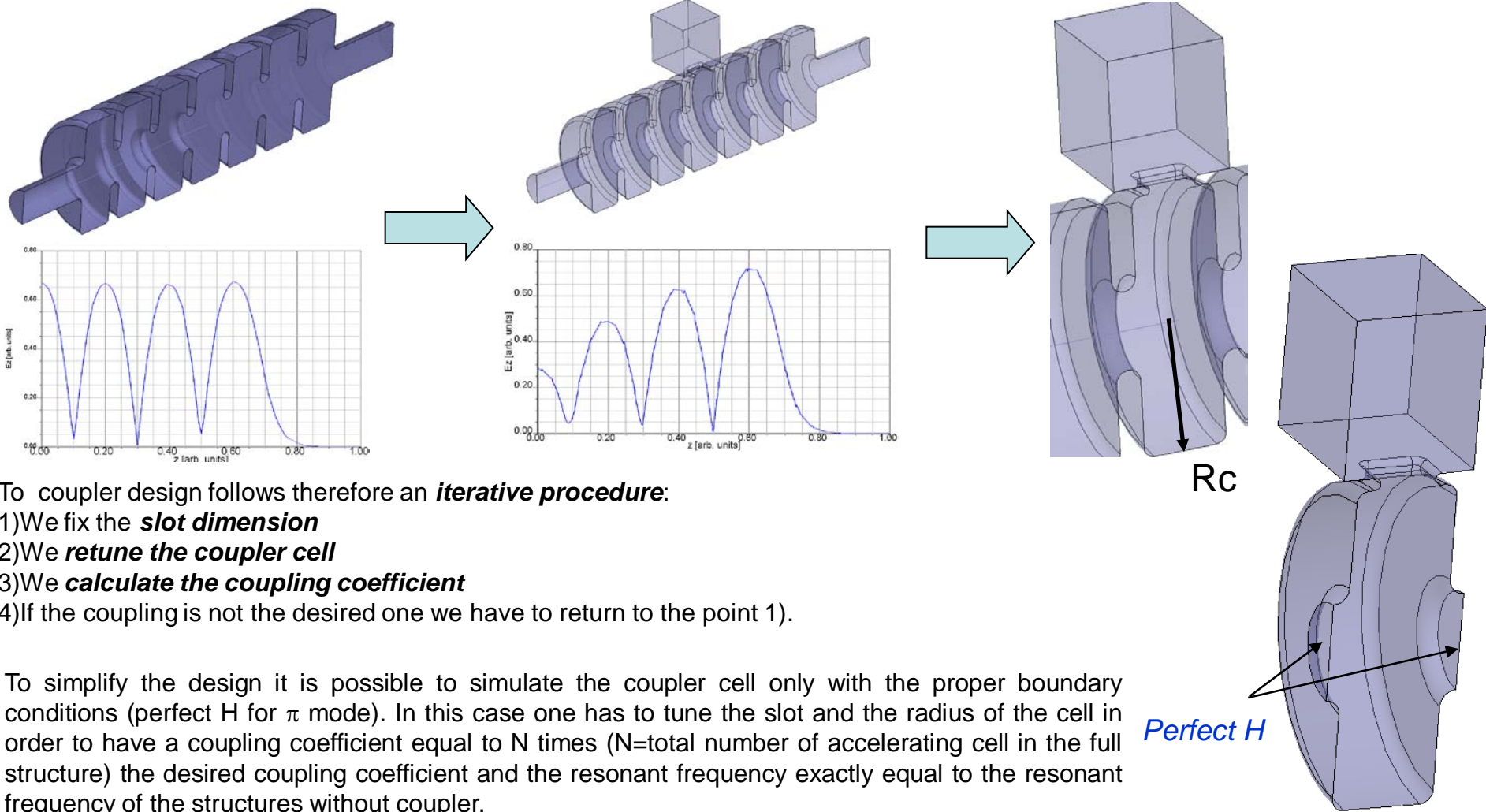

To coupler design follows therefore an **iterative procedure**:

- 1) We fix the **slot dimension**
- 2) We **retune the coupler cell**
- 3) We **calculate the coupling coefficient**
- 4) If the coupling is not the desired one we have to return to the point 1).

To simplify the design it is possible to simulate the coupler cell only with the proper boundary conditions (perfect H for π mode). In this case one has to tune the slot and the radius of the cell in order to have a coupling coefficient equal to N times (N=total number of accelerating cell in the full structure) the desired coupling coefficient and the resonant frequency exactly equal to the resonant frequency of the structures without coupler.

Some References

- C. Suzuki, et al., INPUT COUPLER DESIGN FOR C-BAND ACCELERATING STRUCTURE, PAC 97
- D. Alesini et al., Design of couplers for traveling wave RF structures using 3D electromagnetic codes in the frequency domain, Nuclear Instruments and Methods in Physics Research A 580 (2007)
- N. M. Kroll et al., APPLICATIONS OF TIME DOMAIN SIMULATION TO COUPLER DESIGN FOR PERIODIC STRUCTURES, XX International Linac Conference, Monterey, California
- S. Zheng, A QUANTITATIVE METHOD OF COUPLER CAVITY TUNING AND SIMULATION, Proceedings of the 2001 Particle Accelerator Conference, Chicago.
- V. A. Dolgashev, RF pulsed heating of accelerating structure couplers, presentation, ISG meeting, SLAC, 24 June 02; STUDY OF EFFECT OF HIGH RF MAGNETIC FIELDS ON MULTI-MEGAWATT RF-BREAKDOWN, 2003 HFSS Users Workshop, Los Angeles, California, February 20-21, 2003
- V.A. Dolgashev, HIGH MAGNETIC FIELDS IN COUPLERS OF X-BAND ACCELERATING STRUCTURES, Proceedings of the 2003 Particle Accelerator Conference
- G. Bowden et al., A COMPACT RF POWER COUPLER FOR THE NLC LINAC, Proceedings of the 1999 Particle Accelerator Conference, New York, 1999
- C. Nantista et al., Low-field accelerator structure couplers and design techniques, PHYSICAL REVIEW SPECIAL TOPICS - ACCELERATORS AND BEAMS, VOLUME 7, 072001 (2004).
- Z. Li et al., COUPLER DESIGN FOR THE LCLS INJECTOR S-BAND STRUCTURES, Proceedings of 2005 Particle Accelerator Conference, Knoxville, Tennessee
- S. Doebert et al., COUPLER STUDIES FOR CLIC ACCELERATING STRUCTURES, Proceedings of EPAC 2002, Paris, France
- Jang-Hui Han and Klaus Flottmann, HALF CELL LENGTH OPTIMIZATION OF PHOTOCATHODE RF GUN, Proceedings of ERL07, Daresbury, UK
- X.J. Wang, Design Studies For The LCLS 120 Hz RF Gun, BNL - 67922 Informal Report, December 2000
- F.B. KIEWIET et al., A DC/RF GUN FOR GENERATING ULTRA-SHORT HIGH-BRIGHTNESS ELECTRON BUNCHES, Proceedings of EPAC 2000, Vienna, Austria
- K. Flottmann et al., RF gun design for the TESLA VUV Free Electron Laser, Nuclear Instruments and Methods in Physics Research A 393 (1997) 93-95
- L. Xiao, DUAL FEED RF GUN DESIGN FOR THE LCLS, Proceedings of 2005 Particle Accelerator Conference, Knoxville, Tennessee
- D. H. Dowell et al., RESULTS OF THE SLAC LCLS GUN HIGH-POWER RF TESTS, Proceedings of PAC07, Albuquerque, New Mexico, USA
- A. Variola, HIGH POWER COUPLERS FOR LINEAR ACCELERATORS, Proceedings of LINAC 2006, Knoxville, Tennessee USA
- I.E. Campisi, "State of the Art Power Couplers for Superconducting RF Cavities", EPAC'02, Paris, France, June 2002.
- S. Belomestnykh, "Review of High Power CW Couplers for Superconducting Cavities", Workshop on High-Power Couplers for Superconducting Accelerators, Jefferson Laboratory, Newport Virginia, USA October 2002
- F. Krawczyk, "Interface Issues Between Superconducting Cavities and Power Couplers". LAUR-02-6870, Workshop on High Power Couplers, Newport News, VA, USA
- G. Devanz, Physical Review Special Topics - Accelerators and Beams, Vol.4, 012001 (2001)
- N.P. Sobenin et al. "Thermal Calculations of Input Coupler for Cornell ERL Injector Cavities", EPAC'04, Lucerne, Switzerland, July 2002.
- H. Matsumoto. "High Power Coupler Issues in Normal Conducting and Superconducting Accelerator Application", PAC 1999, New York, USA, March 1999.
- J. Lorkiewicz et al, "Surface TiN Coating of TESLA Couplers as an Antimultipactor Remedy", 10th Int. Workshop on RF Superconductivity, Tsukuba, Japan, September 6-12, 2001
- T. Abe et al. "Development of RF coupler with a Coaxial Line TiN Coated against Multipactoring", PAC'05, Knoxville, Tennessee, USA, May 2005.
- H. Jenhani, "Developments in Conditioning Procedures for the TTF-III Power Couplers", EPAC'06, Edinburgh, UK, June 2006.
- B. Buckley et al. "Emittance Dilution due to Transverse Coupler Kicks in the Cornell ERL". Cornell ERL - 06-02, Cornell, USA, June 2006.
- M. Krassilnikov et al. "Impact of the RF-GUN Power Coupler on Beam Dynamics", EPAC'02, Paris, France, June 2002.
- R. Cee et al. "Beam Dynamics Simulations for the Pitz RF-GUN", EPAC'02, Paris, France, June 2002.
- S. Prat, "Power Couplers for the XFEL, Industrialisation Process", CARE/ELAN Document 2006-003.

Thank you for your attention