



# HL-LHC Vacuum components procurement needs

G. Riddone on behalf of the WP12

6<sup>th</sup> February 2018

# Content

- Introduction to HL-LHC project and Plan
- Cryogenic Temperature sectors of the LSSs
- Room Temperature sectors of the LSSs
- Controls and vacuum design for high irradiation environment
- Summary

# Introduction to HL-LHC project and Plan

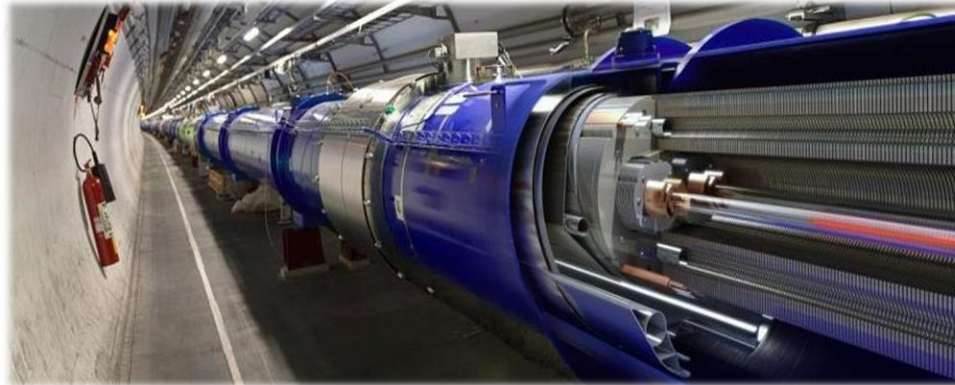

- CERN : 120 km of vacuum vessels, of which 100 km in LHC alone
  - 4x 23 km of LHC are cold (1.9 or 4.5 K): 2 beam pipes + 2 insulation volumes (magnets + QRL)
  - 2x 4 km of LHC are at Room Temperature (RT) : 1 or 2 beam pipes + no insulation
- The HL-LHC vacuum system is made of:
  - Cryogenic Temperature vacuum
  - Room Temperature vacuum



Systems under **TE-VSC group** responsibility

# VSC - Vacuum, Surface and Coatings group

Design, construction, installation and operation of the HL-LHC vacuum system

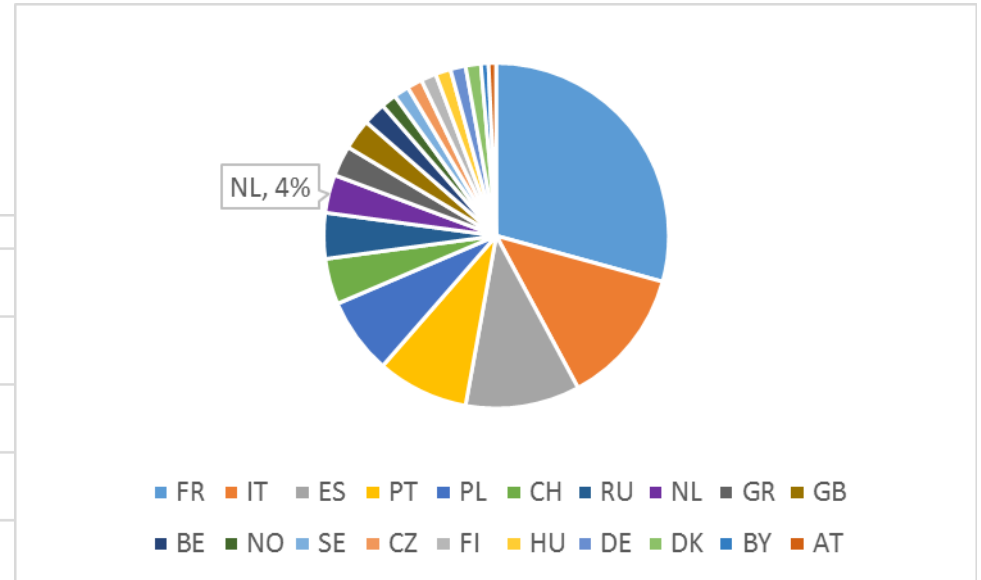
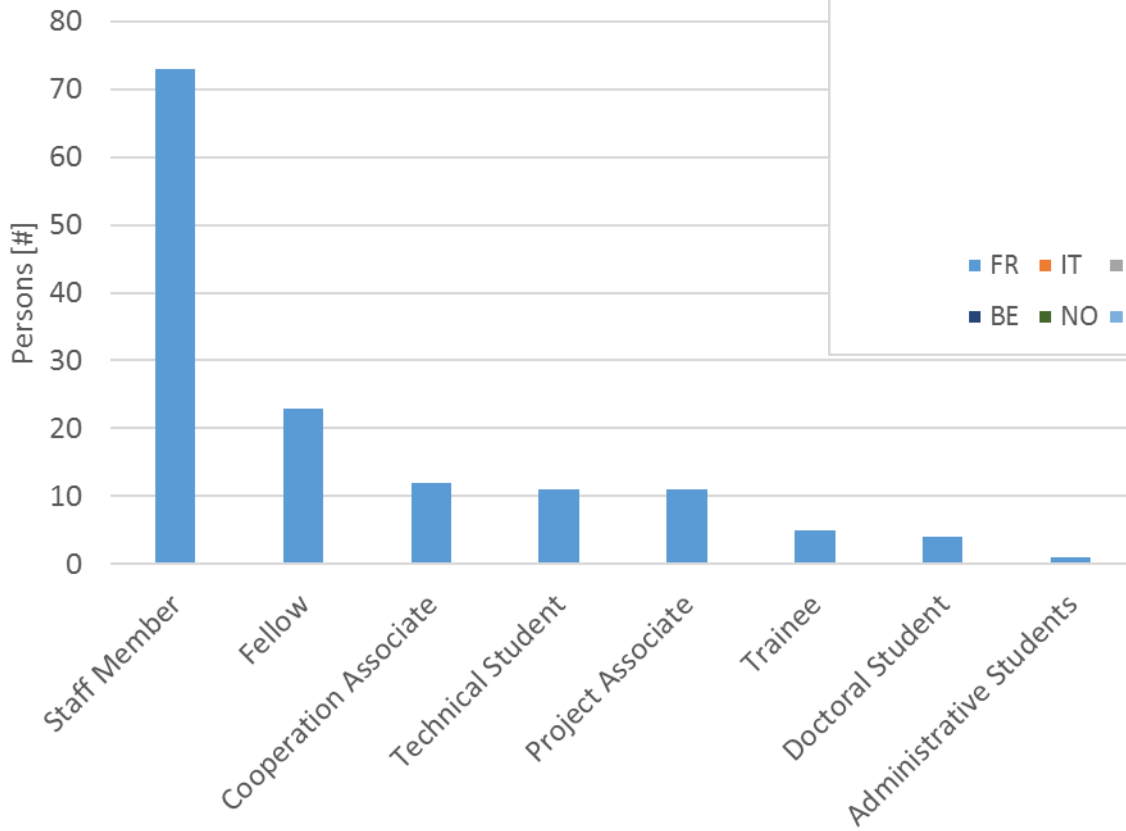

Several collaborators from different countries and institutes

# LHC HL-LHC plan

- HL-LHC will need modifications / upgrades on significant portions (>1.2 km) of LHC vacuum., e.g. new beam screens (shielded, non-shielded) and new layout
- Many components need to be designed, procured and installed during two long shut-down periods (LS2 and LS3):
  - LS2 : 2019 – 2020, preparation is NOW
  - LS3 : 2024 – mid 2026, major activities

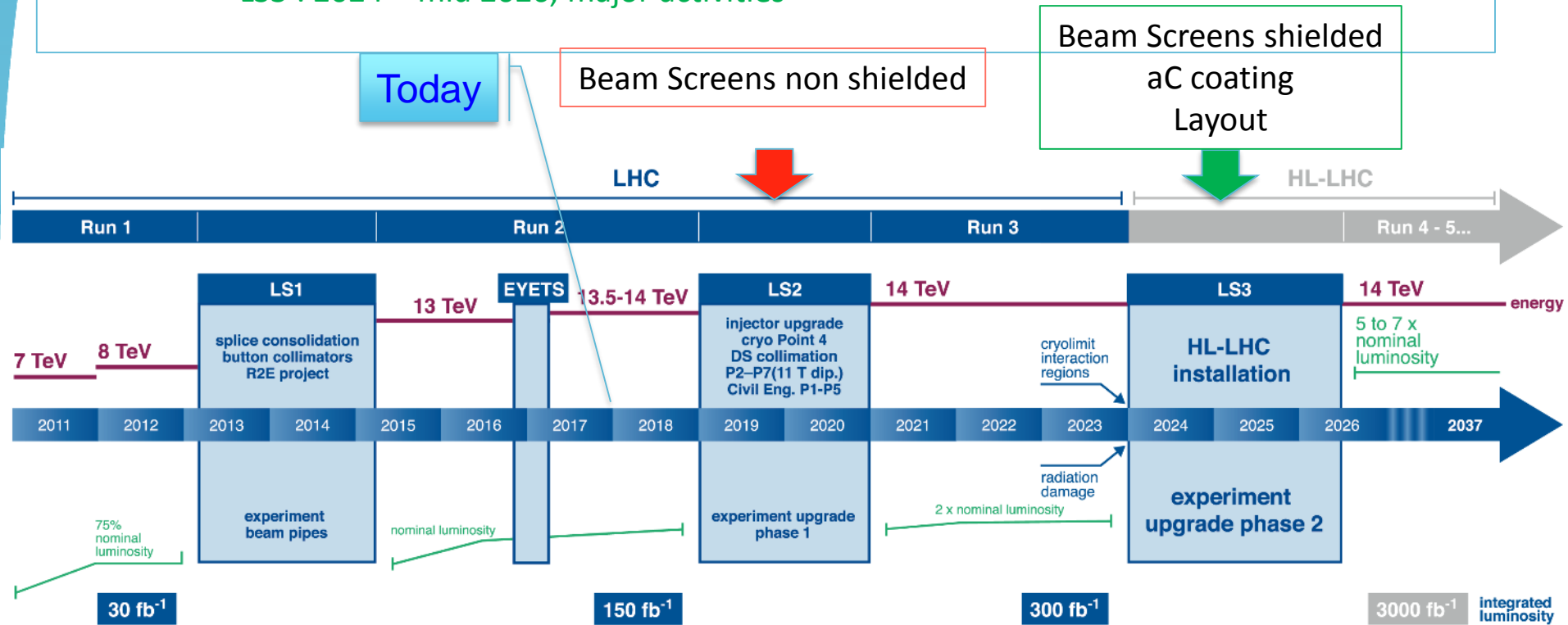

# Content

- Introduction to HL-LHC project and Plan
- Cryogenic Temperature sectors of the LSSs
  - New beam screens (BS) 

LS2	LS3
-----	-----
  - New vacuum interconnections 

LS2	LS3
-----	-----
- Room Temperature sectors of the LSSs
- Controls & vacuum design for high irradiation environment
- Summary

# New beam screens

## Design is under finalisation

- Cu colaminated, perforated P506 beam screen
- Different shapes and several apertures
- Tungsten alloy shielding
- Stainless steel cooling tubes
- Cu thermal links
- Amorphous-Carbon (a-C) coating (100 nm)

## LS2 (2019-2020):

- consolidation and production of the beam screens in LSS2 and LSS8:

## LS3 (2024-2026):

- new beam screens in LSS1 and LSS5 and in-situ coating

## Assembly of the beam screen

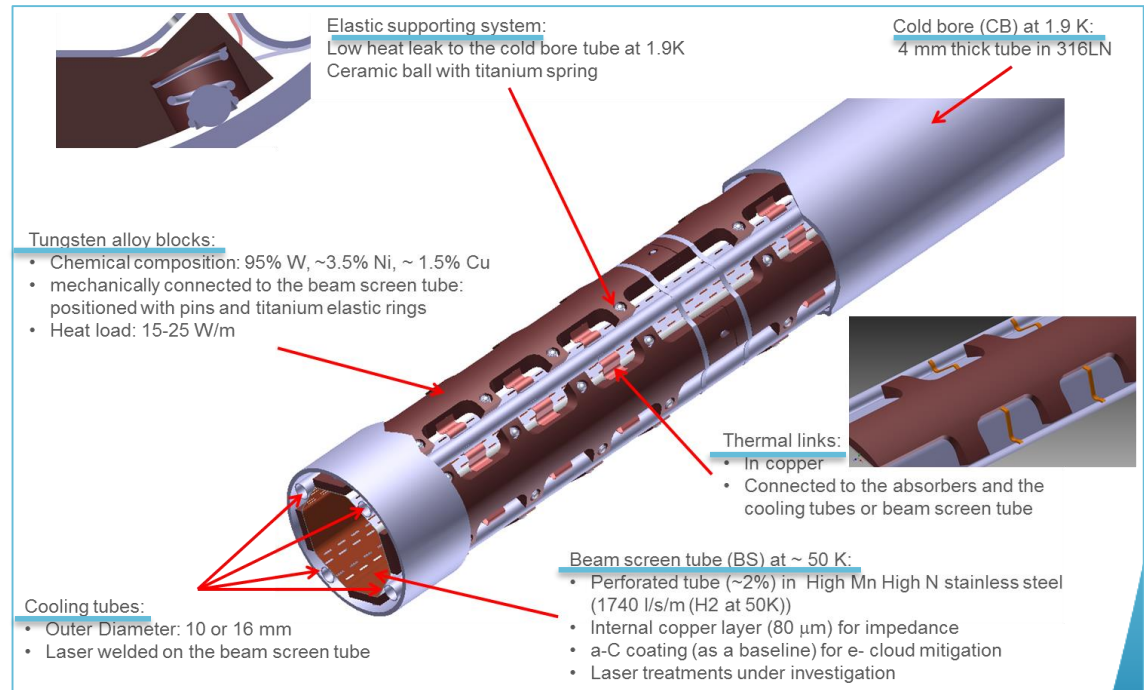
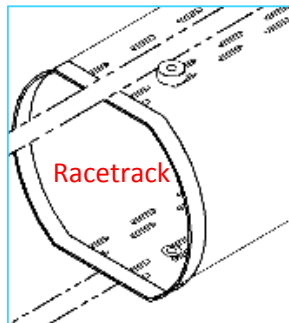
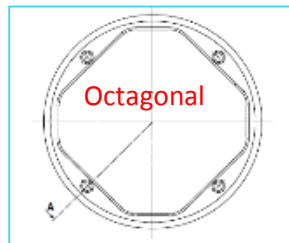

# Beam screens with shielding



Beam screen prototype for cryogenic test

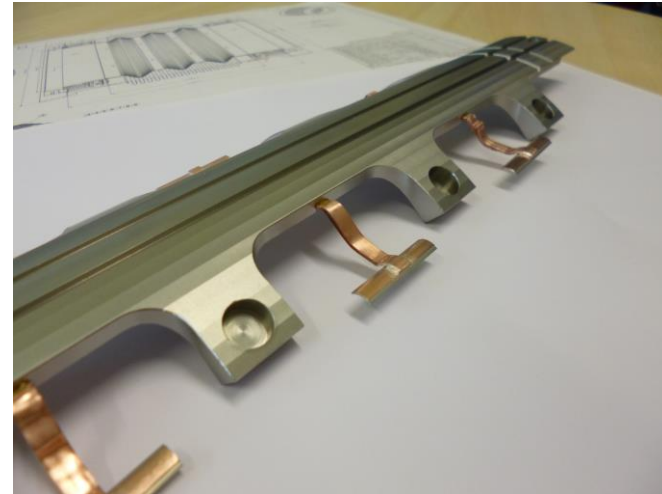

Tungsten absorber prototype with copper thermal links



Beam screen finishing parts



Copper thermal links

# Beam pipe interconnects

- Similar or different diameter or shape (aperture matching)
- Dedicated **Plug-in Modules** to assure RF screening and low impedance: Cu plated stainless steel
- **Cold-Warm Transition** for connections at different temperature

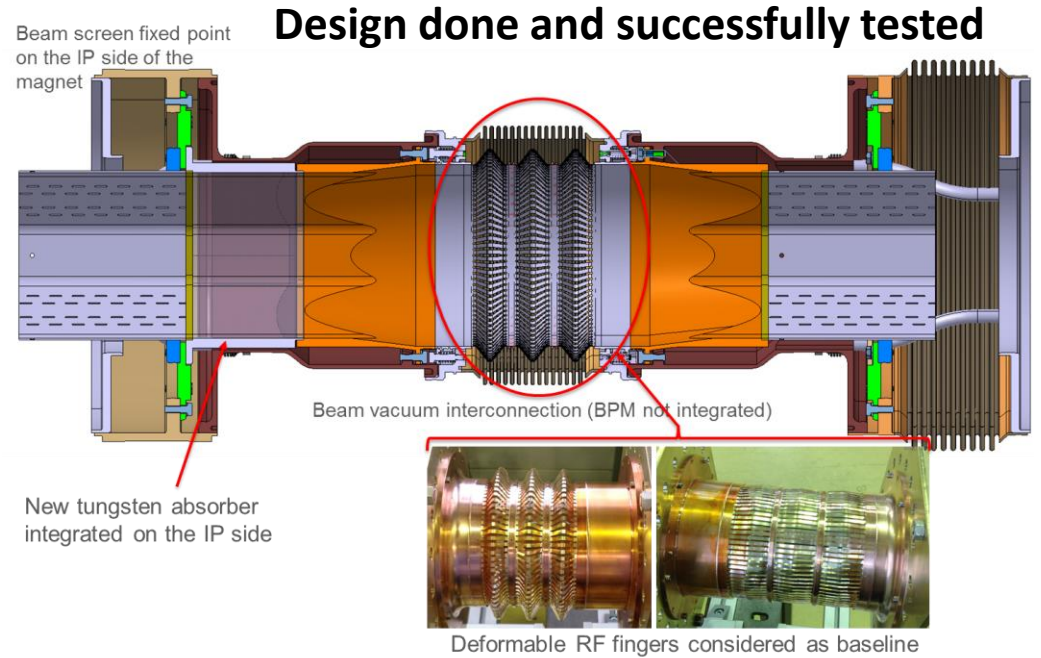

A typical LHC interconnection

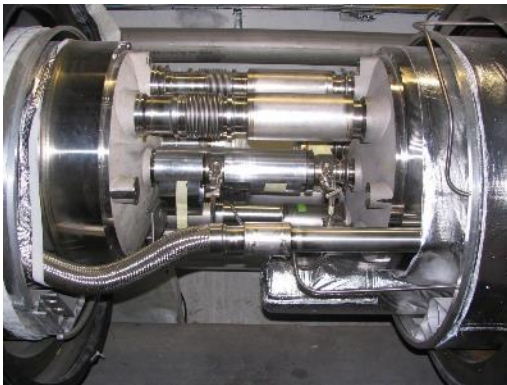

CW transition

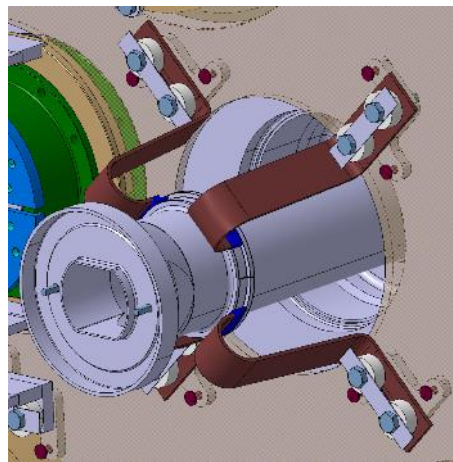

About **50** new interconnections are needed

- 20 @ LS2
- 30 @ LS3

About **60** CW transitions are needed

- 20 @ LS2
- 40 @ LS3

# Content

- Introduction to HL-LHC project and Plan
- Cryogenic Temperature sectors of the LSSs
- Room Temperature sectors of the LSSs LS2 LS3
- Controls & vacuum design for high irradiation environment
- Summary

# Room temperature vacuum system

- ~ 6 km length
- Bake-able vacuum system
- Relies on TiZrV getter film pumping after activation at ~ 200°C

Item in LSS	Length (m)
SAM @ cryo T	~ 1 365
LSS @ RT baked	~ 1 000
LSS @ RT with baked NEG	~ 4 800
Total length under vacuum	7 227

## “Combined” sector in both side of each experiment

Both beams circulates in the same beam pipe



## “Twin” sector

Beams circulate in different beam pipes



# Layout modifications

## Long Straight Section 8

Installation of a mask (TANB) to protect the D2 cold mass.

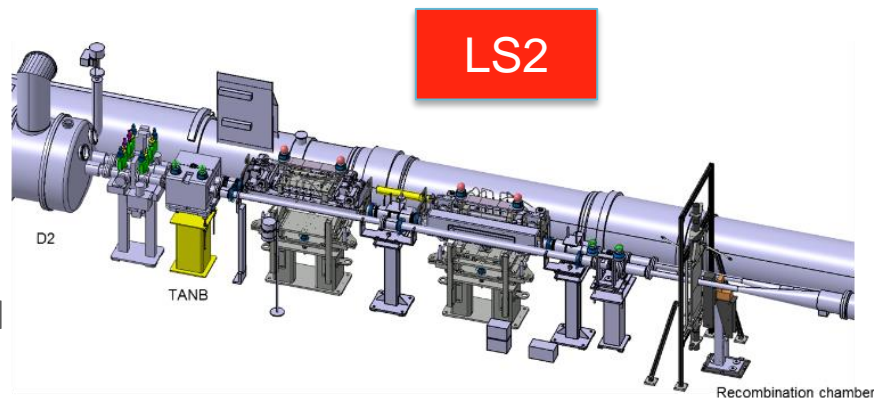

## Long Straight Section 1&5 (1 km) will be completely new

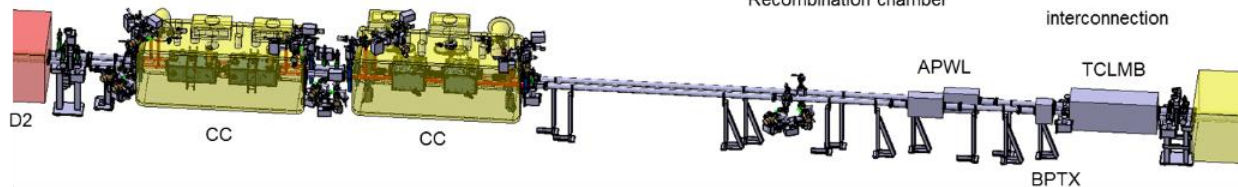
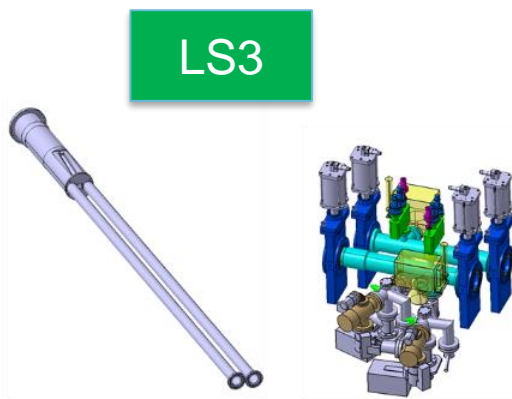
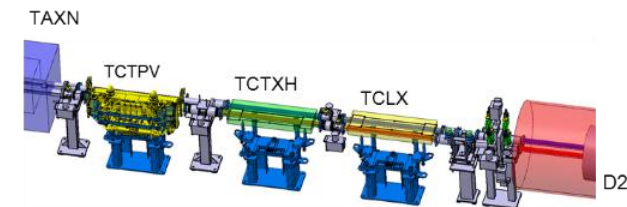

### Main needs

- raw material (Cu OFE, stainless steel, Al 6000 series, Ti,..)
- vacuum chambers
- supports for remote alignment,
- warm modules,
- bellows
- flexible hoses
- gaskets
- UHV flanges,
- bake-out equipment,...

## Warm modules

- Modular system:  $\sim 1800$  in the LHC ring
- Bellow shielding to optimize beam impedance
- RF bridge with several shapes (circular/elliptical)
- Ag coated CuBe fingers
- Rh coated insert
- Allow thermal expansion during bakeout ( $\pm 20$  mm stroke)
- Can accommodate instrumentation ports



## Vacuum chambers

- Cu, Stainless steel Cu plated
- Circular, elliptical, transitions
- Specific chambers e.g. Y chamber
- Various ID diameters: 80, 91, 212.7, 250 mm
- NEG coated at CERN
- Including chamber supports



# Bake-out System

Mobile and permanent system



Collars



Thermocouples



Bake-out jackets

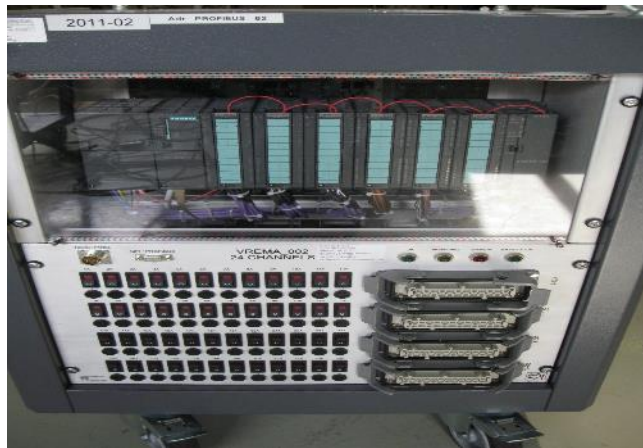





Bake-out racks

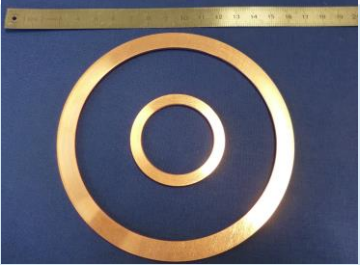

Heating tapes

# Gaskets for vacuums systems

Gasket type		Status	Remark
Copper CF gasket		Blanket contract	NL company
Diamond aluminium gasket		Blanket contract	NL company
Metallic seal		New suppliers sought	
Elastomeric O'Rings		New formulation for high irradiation dose applications being characterized at CERN	New suppliers to identify for series

# Quantities for cryo and RT sector components

Component	LS2	LS3	Total
Shielded Beam Screen		40	40
Non-shielded Beam Screen	30	15	45
Vacuum bellows	25	211	236
Vacuum chamber	15	65	80
Vacuum supports	30	130	160
Vacuum bakeout jackets	20	180	200
Vacuum flanges	80	600	680
Sector valves	8	52	60
Vacuum gauges		56	56
Vacuum seals	50	250	300
Vacuum pumps	10	40	50
Vacuum collars	30	120	150
Vacuum valves	10	50	60

# Content

- Introduction to HL-LHC project and Plan
- Cryogenic Temperature sectors of the LSSs
- Room Temperature sectors of the LSSs
- Controls & vacuum design for high irradiation environment
- Summary

LS2

LS3

# Controls

- Specific components and materials for radioactive environment
- PCB production and components assembling
- Mounting, cabling and test of different types of crates
- Specific cables: radiation hard, High Voltage, coax/triax cables and connectors

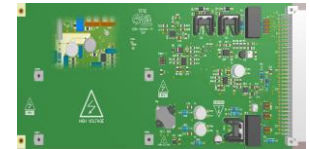
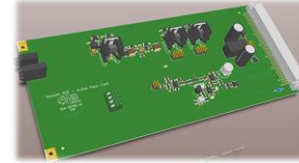
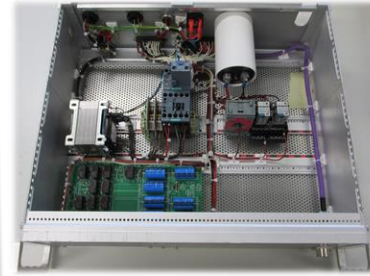
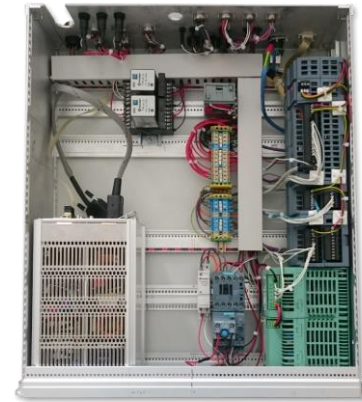

## Preliminary estimation for HL-LHC

Component	Quantity
Sputter Ion Pump controller	60
Sector Valve controller	60
Interlock	60
Penning/Pirani gauge (LSS) controller	70
Penning/Pirani/Piezo gauge (ARC) contr.	850
Mini-racks (ARC)	130
Fixed Pumping group controller	10
Euro crates	300
PLCs	150
Long cables and connectors	280

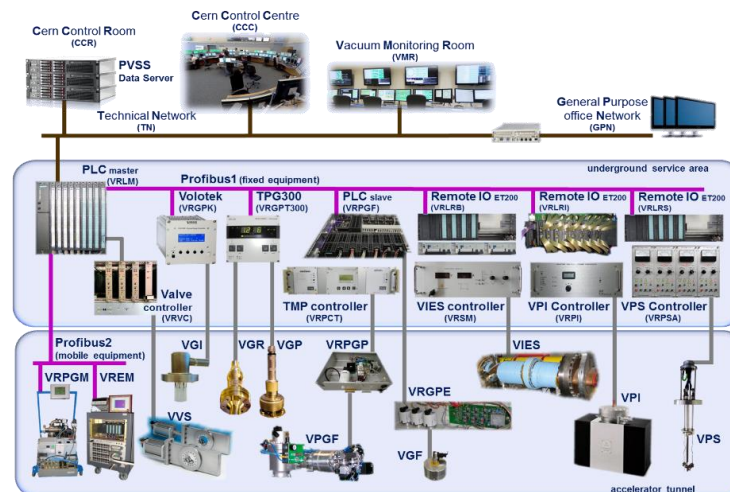
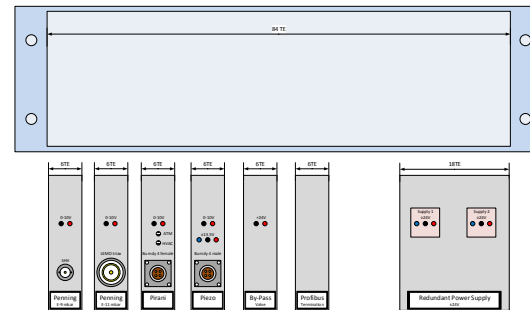

# Vacuum design for high irradiation environment

The level of radioactivity from activated materials will require new tools for remote manipulation, enhanced reality, supervision (minimize the radiation doses for people, during interventions)

Vacuum modules: robot for the bellows compression to remove the collimator

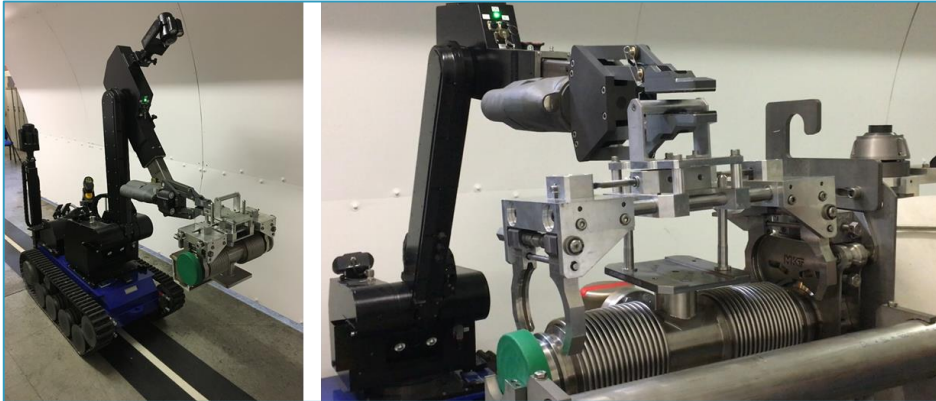

Dummy valve prototype for VAX area



New UHV connectors based on Shape Memory Alloys for high demanding areas



LS3



# Summary

## ■ Ongoing studies

- design of beam screens, interconnects, cold warm transitions, vacuum layout

## ■ Cryogenic temperature vacuum system

- Design and procurement underway
- Prototyping started



Shielded beam screen:

- Full scale prototype – Q2/2019
- Interconnect
- CW Transition prototype: Q2 2018

## ■ Room temperature vacuum system

- Design initiated
- Procurement to start by Q2/2018-2019



Finalisation of layout: mid 2018

## ■ Will need

- UHV vacuum components
- Assembly and installation of interconnections and vacuum modules
- Components and devices for remote interventions
- Electronics & controllers



Cold bore machining from 2018



First beam screen tube Q1/2019



2018-2023

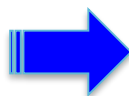

**HL Make or Buy WP12 Brochure**

<https://edms.cern.ch/document/1748379/1.1>



***Thanks for your attention***