



**PS/SPS users' meeting
CERN
25 October 2018**

TORCH – modification of T9 concrete floor

Thierry Gys for TORCH

Modified concrete floor of T9 – overall view



Modified concrete floor of T9 – detailed view



Modified concrete floor of T9 – detailed view (cont'd)



Acknowledgements

- !!!! Many thanks to all people involved !!!!

Spare slides

Oct/Nov 2018 PS/T9 beam tests for TORCH

schedule issue date: 25-Sep-2018

Version: 2.3.5

Mon	Tue	Wed	Thu	Fri	Sat	Sun	Mon	Tue	Wed	Thu	Fri	Sat	Sun	Mon	Tue	Wed	Thu				
22	23	24	25	26	27	28	29	30	31	1	2	3	4	5	6	7	8				
Oct	Oct	Oct	Oct	Oct	Oct	Oct	Oct	Oct	Oct	Nov	Nov	Nov	Nov	Nov	Nov	Nov	Nov				
43							44							45				46			
EA-Irrad																					
LHCb TORCH																					
ALICE TOF-MRPC																					
CLOUD																					
nTOF																					

Personnel assignments for TORCH (circled in red):
 - EA-Irrad: T. Gys (Oct 22-31), R. Garcia Alia (Nov 12-15)
 - LHCb TORCH: T. Gys (Oct 22-31), R. Garcia Alia (Nov 12-15)
 - ALICE TOF-MRPC: F. Guber (Oct 22-31), C. Williams (Nov 1-11), J. Kirkby (Nov 12-15)

- TORCH main and only user
 - Mon 22nd Oct – Mon 12th Nov 2018: 21 days
 - Last beam time before LS2

Former TORCH layout with “mini-TORCH” quartz radiator and optics

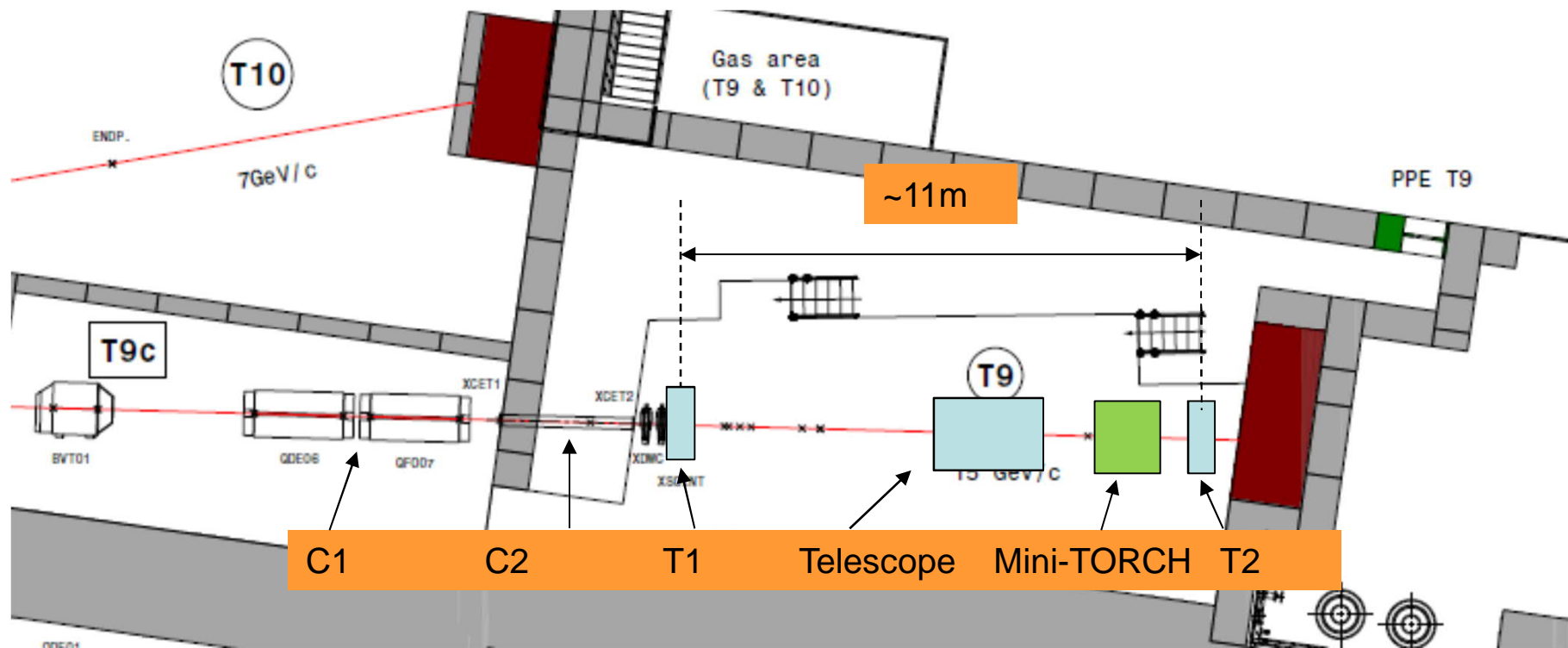

Former TORCH layout with “mini-TORCH” quartz radiator and optics – photograph

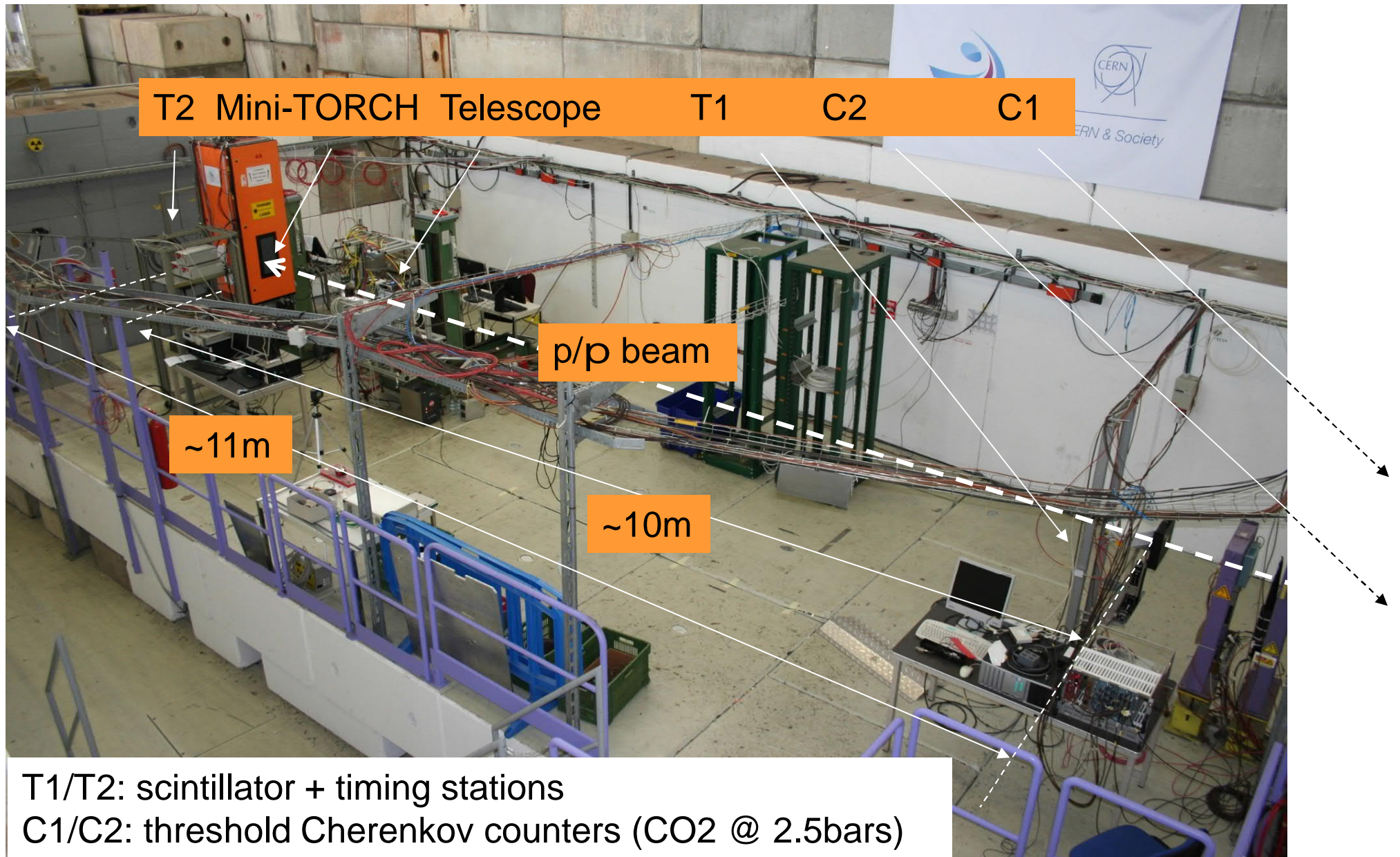

New TORCH layout with full module quartz radiator and optics

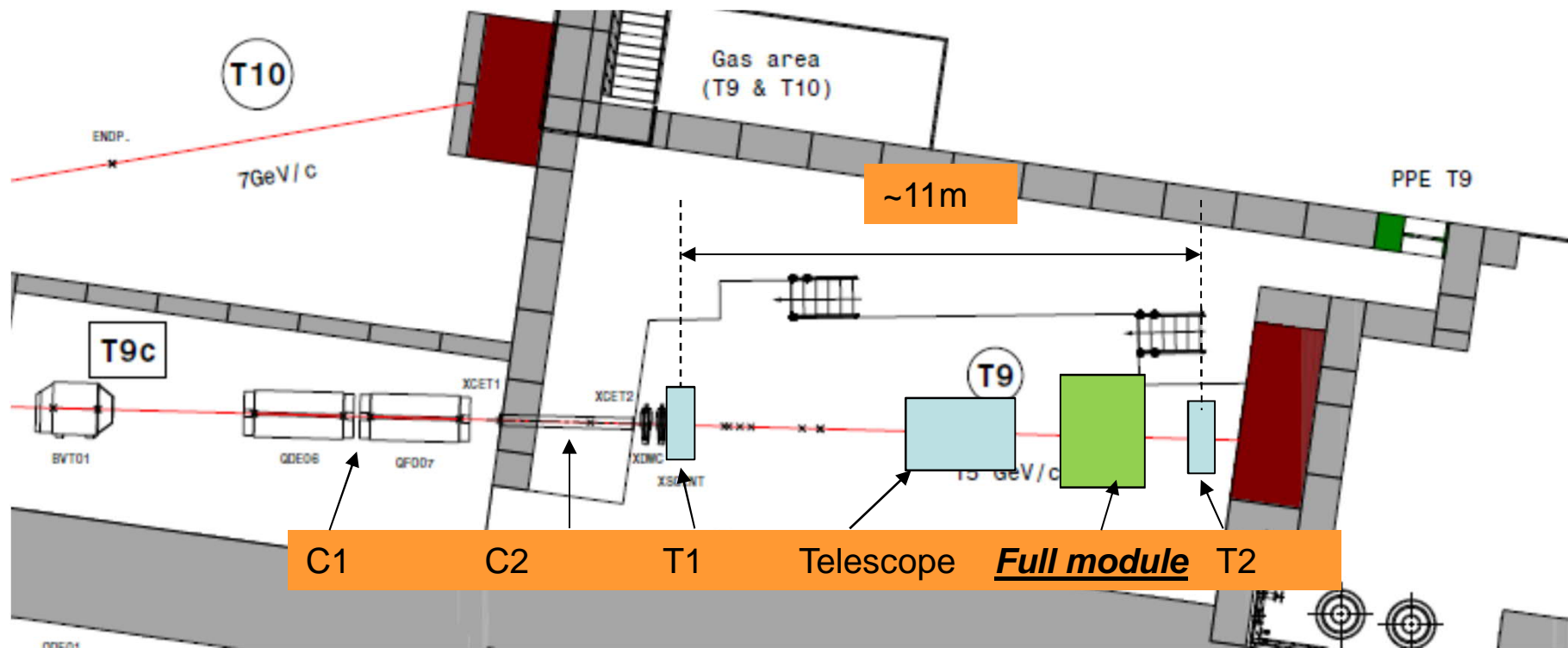

Full module height and position vs beam height – existing concrete floor

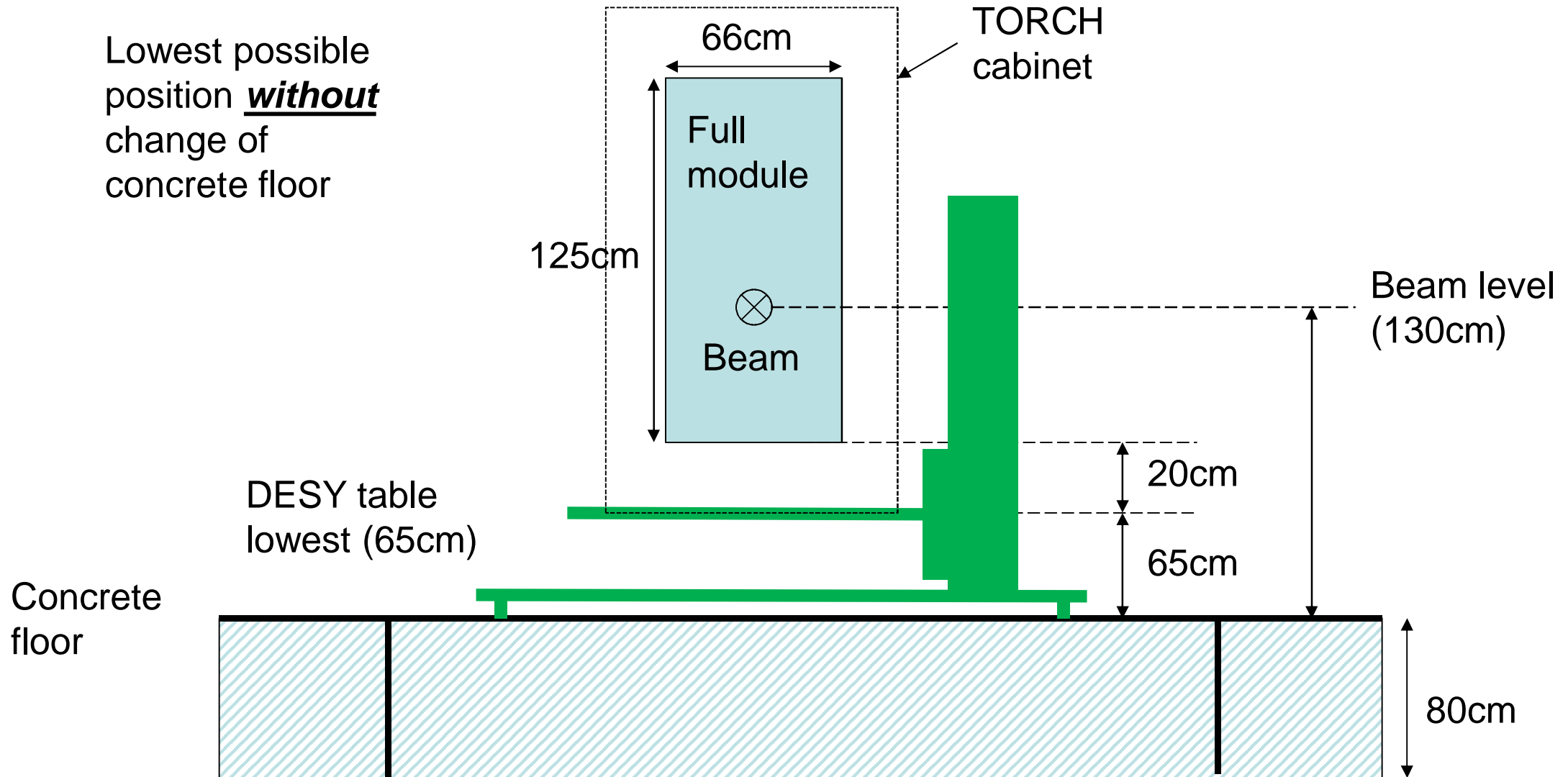

Full module height and position vs beam height – modified concrete floor

Lowest possible position with change of concrete floor

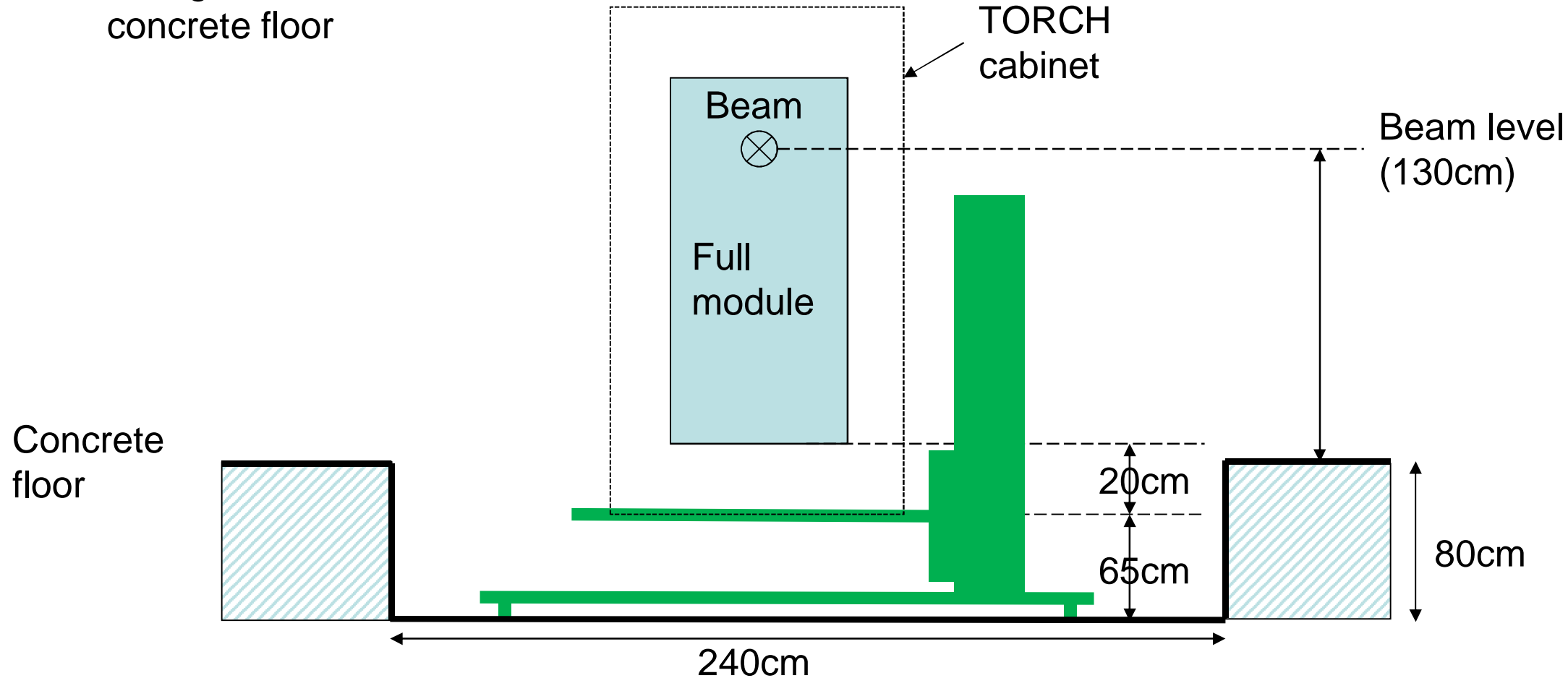

Modified concrete floor – TORCH request

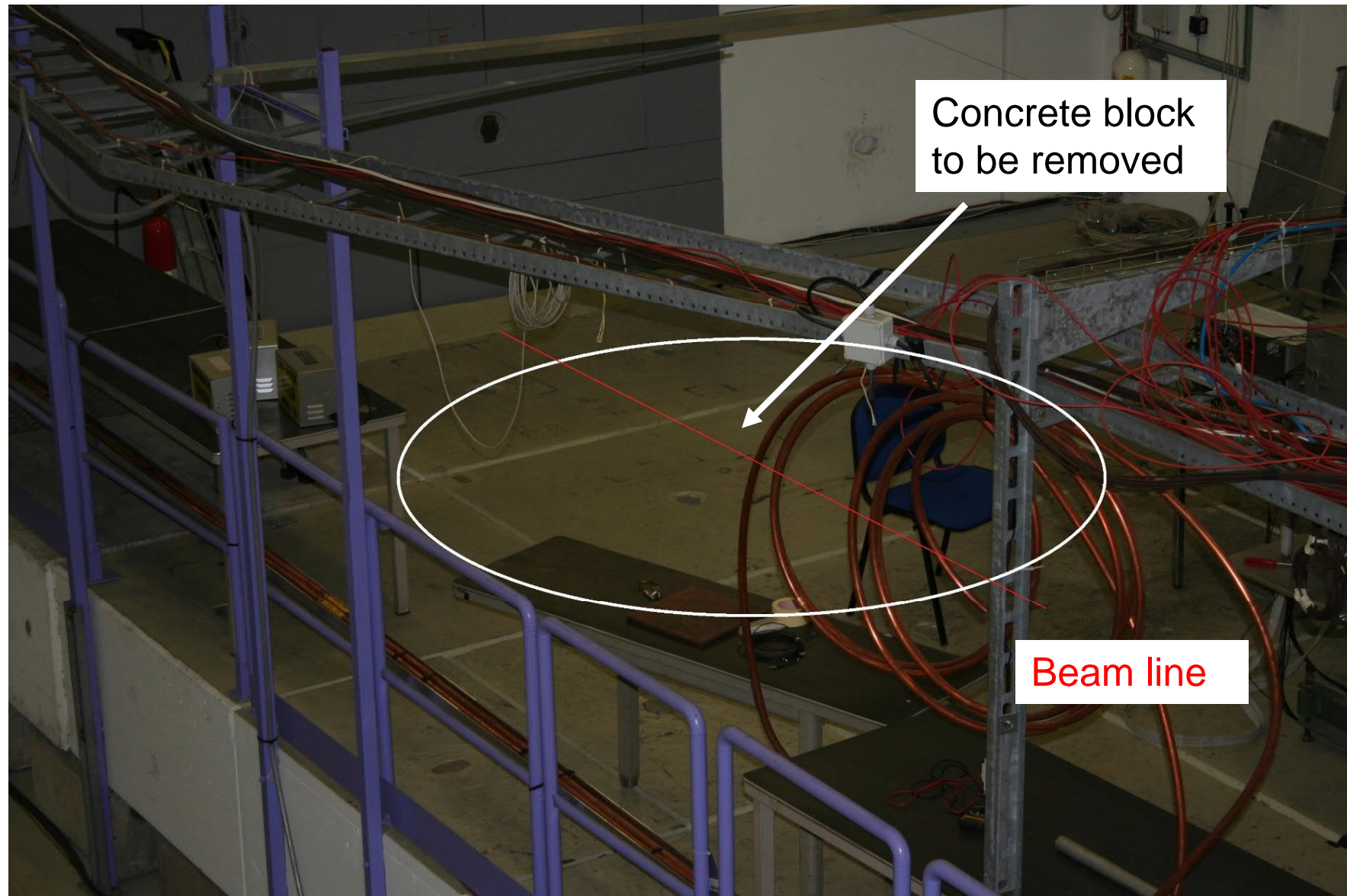

Various

- Details to be discussed
 - DESY table footprint vs concrete block footprint
 - Craning and handling
 - Safety
 - ...