

The GBAR experiment

Measuring free fall of antimatter

László Liskay

CEA, IRFU, University Paris-Saclay, France

for the GBAR collaboration



Outline

- Measuring the acceleration of the free fall of antimatter
- Creating antihydrogen ion
- Antiprotons: ELENA and decelerator
- Positron source and trap(s)
- Cooling antihydrogen ions
- Status and outlook

The GBAR (Gravitational Behaviour of Antihydrogen at Rest) experiment at CERN

- Aim: direct observation of the gravitational free fall of antihydrogen (three experiments at CERN/AD: AEGIS, GBAR and ALPHA-g)
 - test of the weak equivalence principle
- Requires very cold antihydrogen (10 μK)
 - cooling is not possible when using neutral atoms
- Distinctive idea: cool down positively charged antihydrogen ion, then photodetach the extra positron

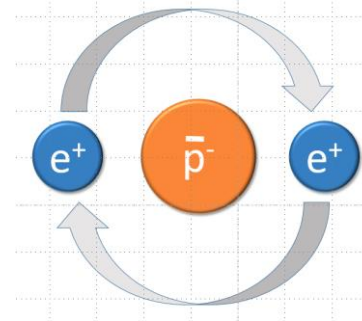
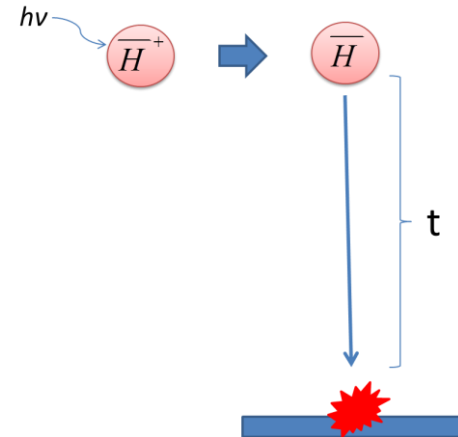

Goal

$$\frac{Dg}{g} \leq 1\%$$

J. Walz and T. Hänsch, General Relativity and Gravitation 36, 561 (2004).

P. Pérez and A. Rosowsky, Nucl. Inst. Meth. A 532 (2004) 523-532.



Anti-ion creation in a positronium target cloud

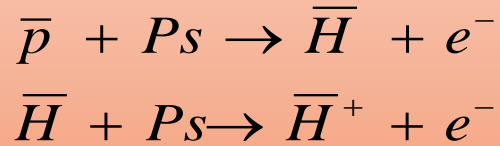

- Two reactions, high cloud density is essential

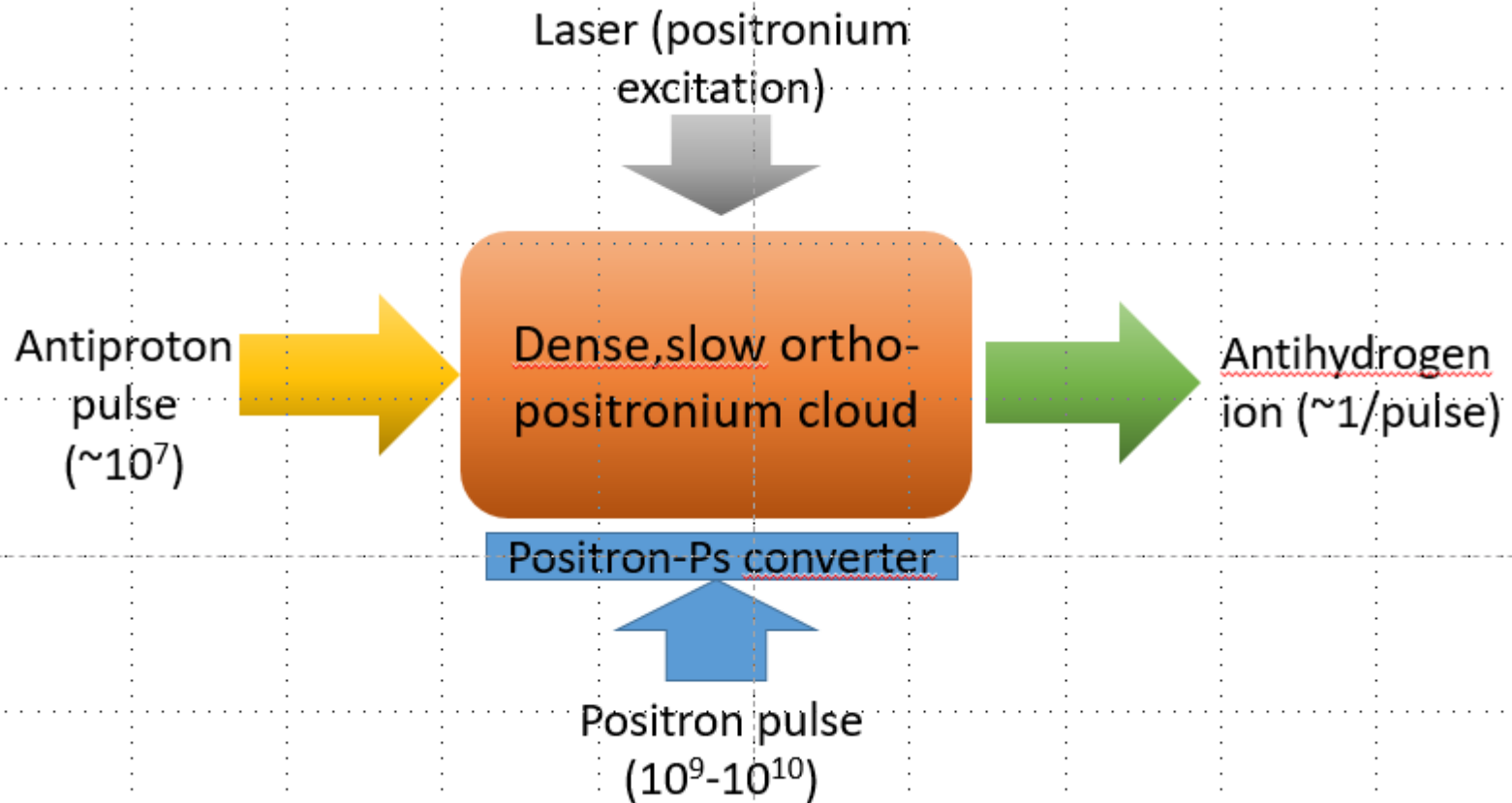

Cross section using excited positronium

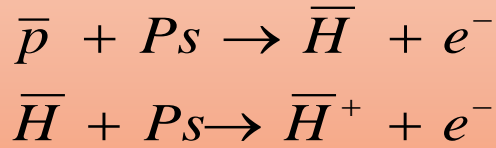

First reaction

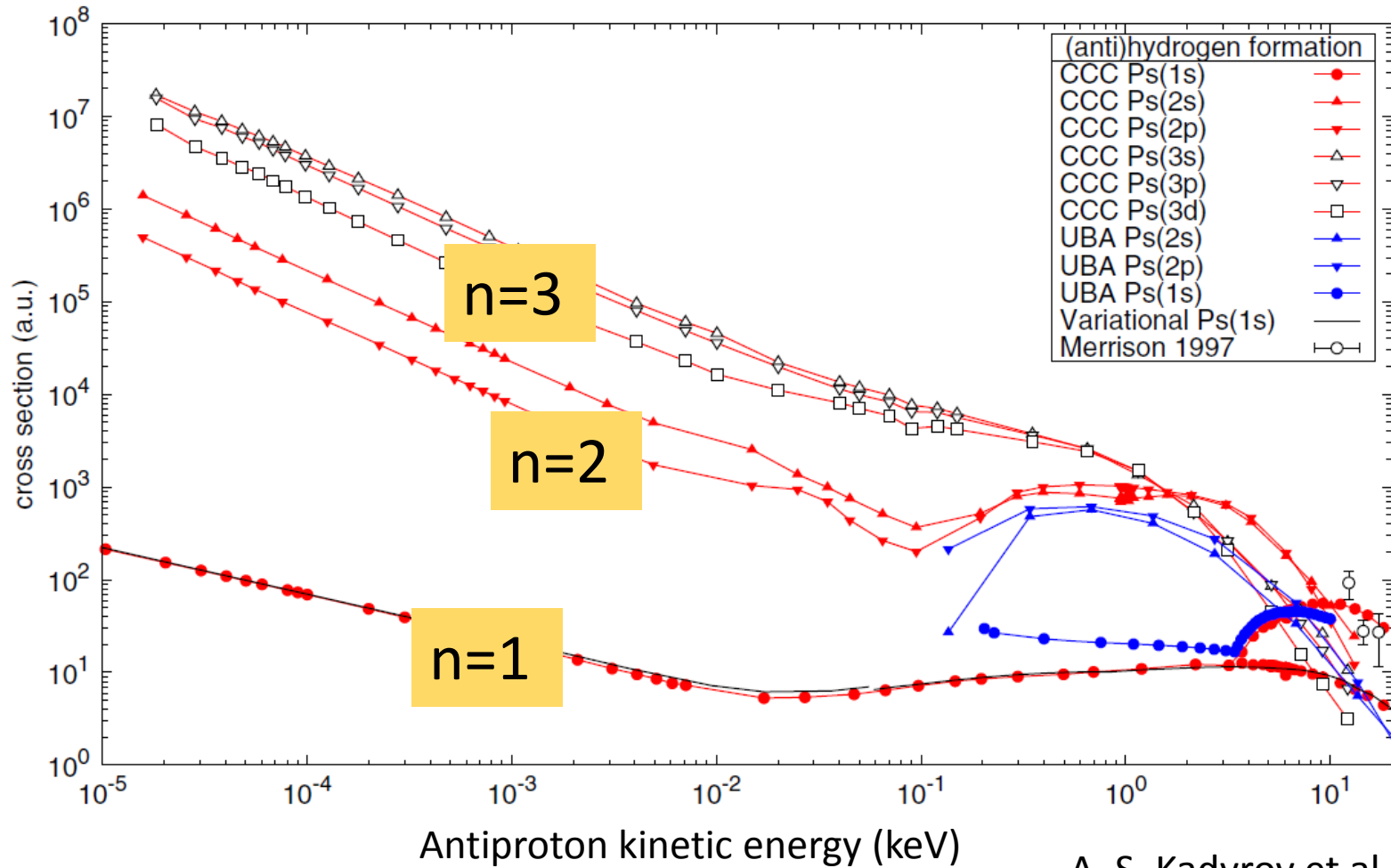

Detection of free fall

Measure time-of-flight until annihilation (free fall)

- Start signal: photodetachment laser
- Stop signal: annihilation
on the chamber wall (Micromegas trackers + scintillation detectors)

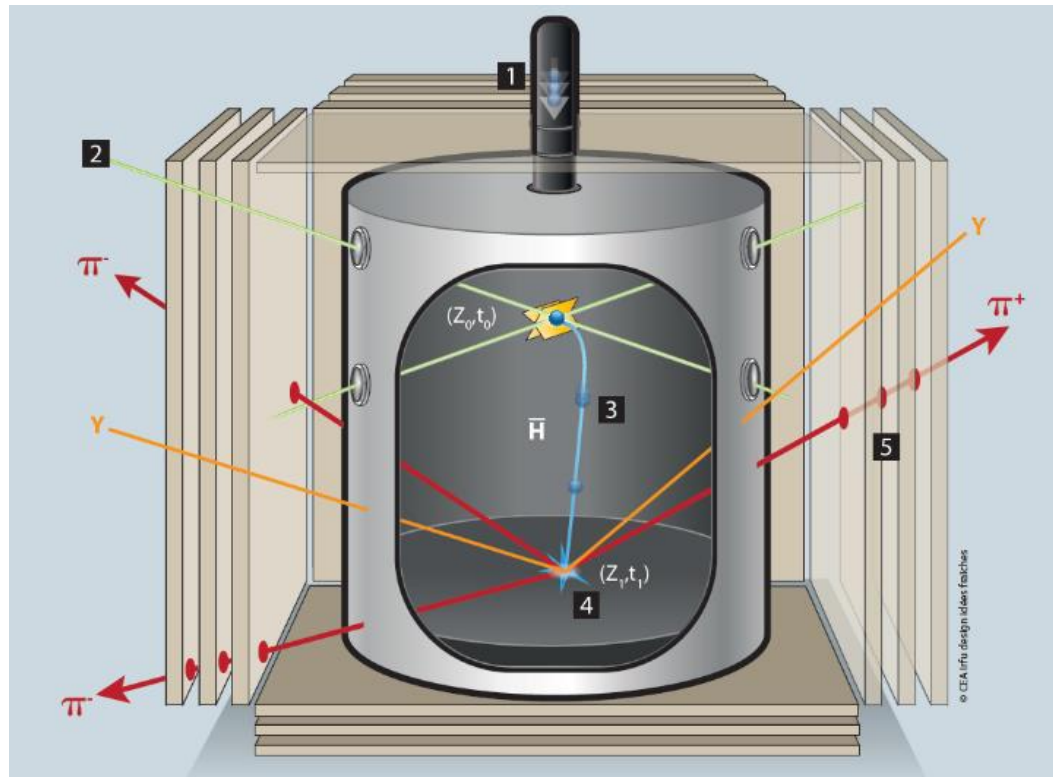

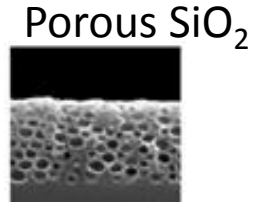
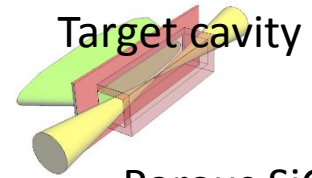
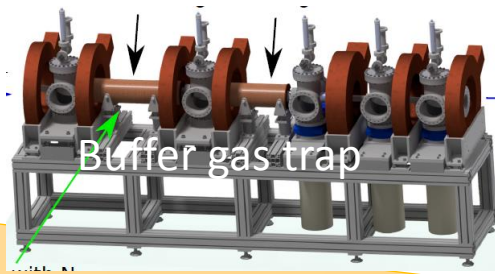
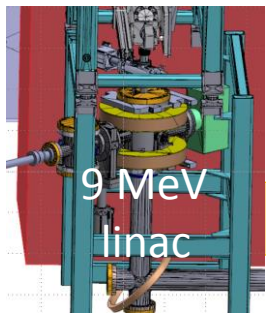

Ps (~ 50 meV)
+ pbar (\sim keV)
reaction

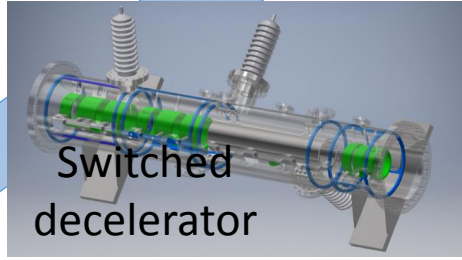

100 keV
Cycle: 108 s

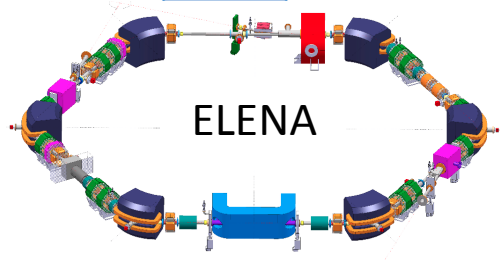

(100 keV antiproton)

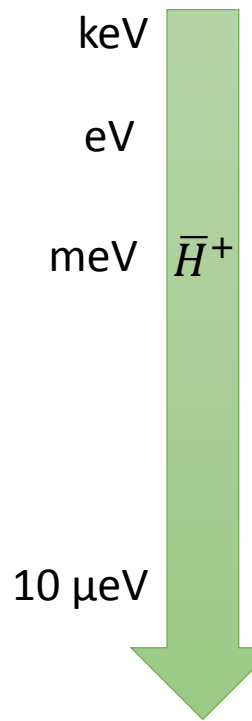

Capture trap

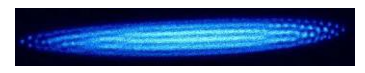

Doppler sympathetic cooling (Paul trap)



Raman sideband cooling

Photodetachment + free fall

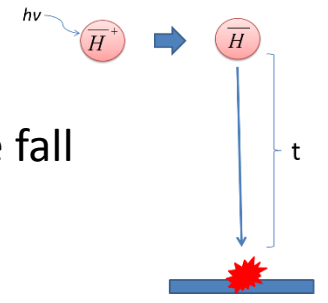

Antiprotons: CERN AD / ELENA

AD (Antiproton Decelerator): 5.3 MeV
(experiments: AEGIS, ALPHA, ASACUSA, ATRAP, BASE)



New ELENA facility: 100 keV antiprotons
(GBAR is the first user)

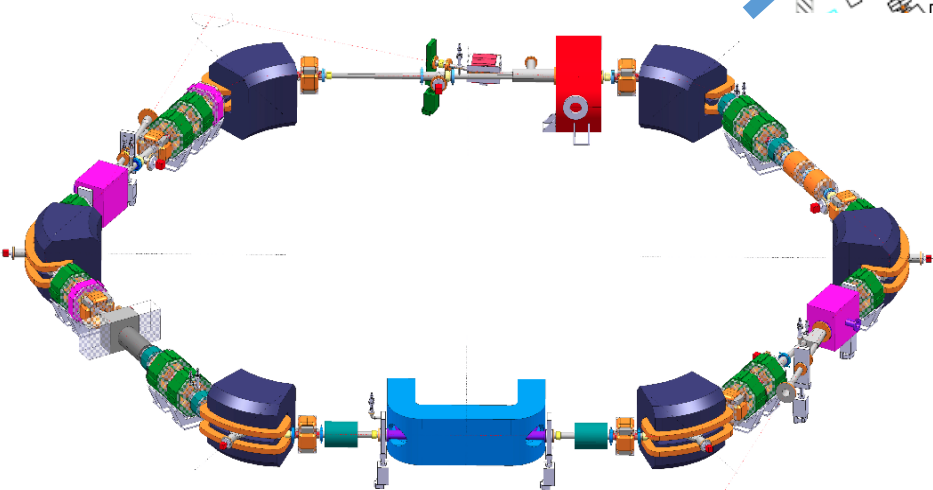
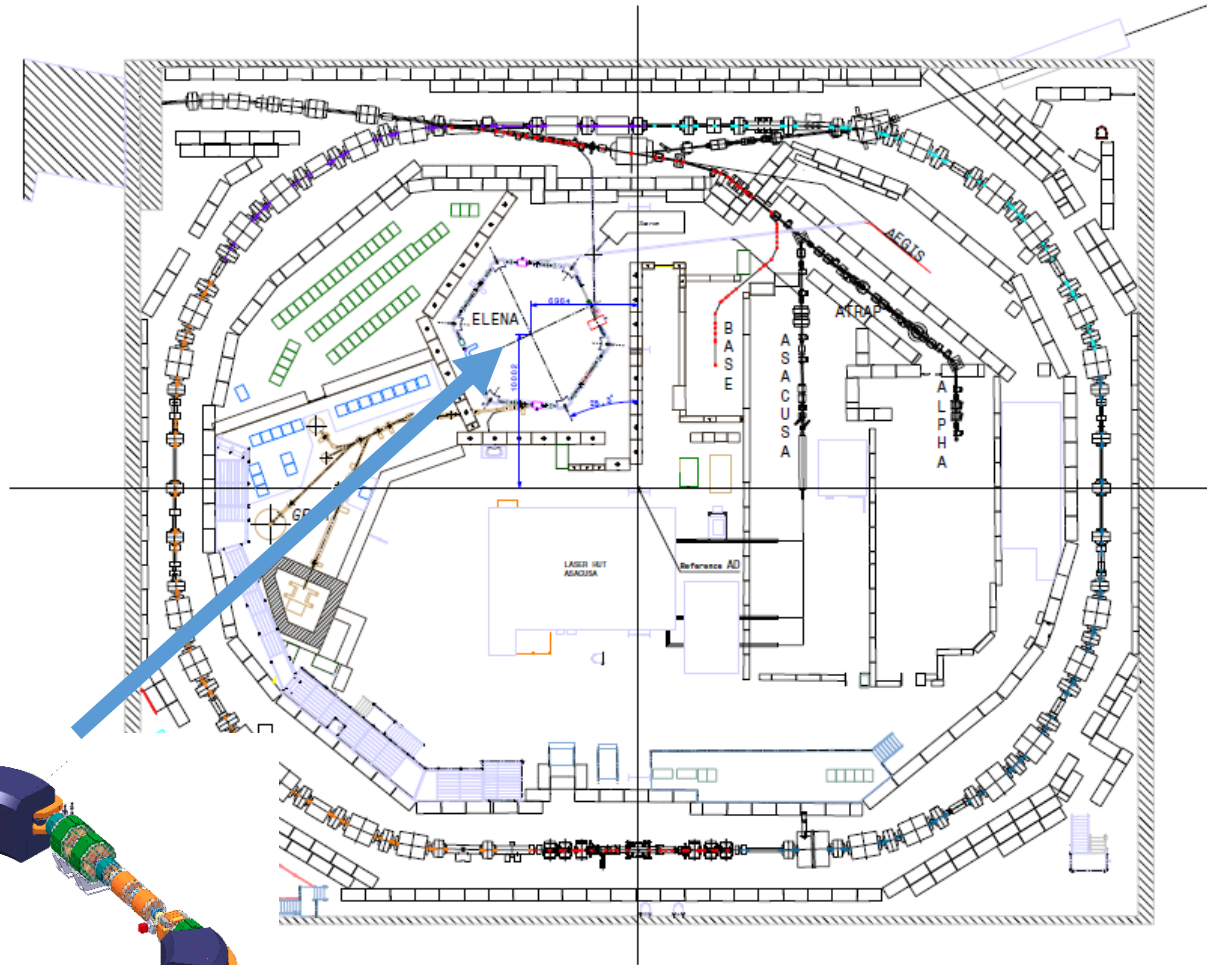

Status: beam for GBAR but still not completely commissioned

Antiproton deceleration after ELENA

100 keV \bar{p} pulse
300 ns (1.3 m)
 4π mm mrad

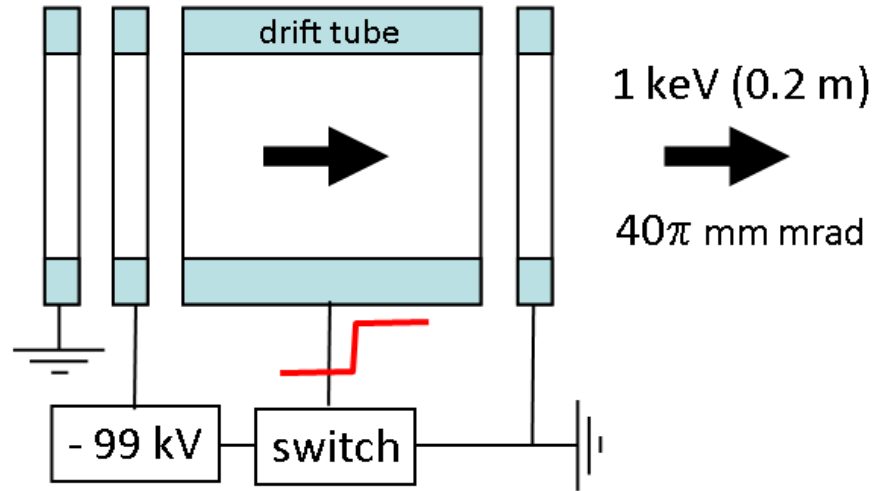

- Antiprotons at ~ 1 -10 keV energy
- Switched decelerator

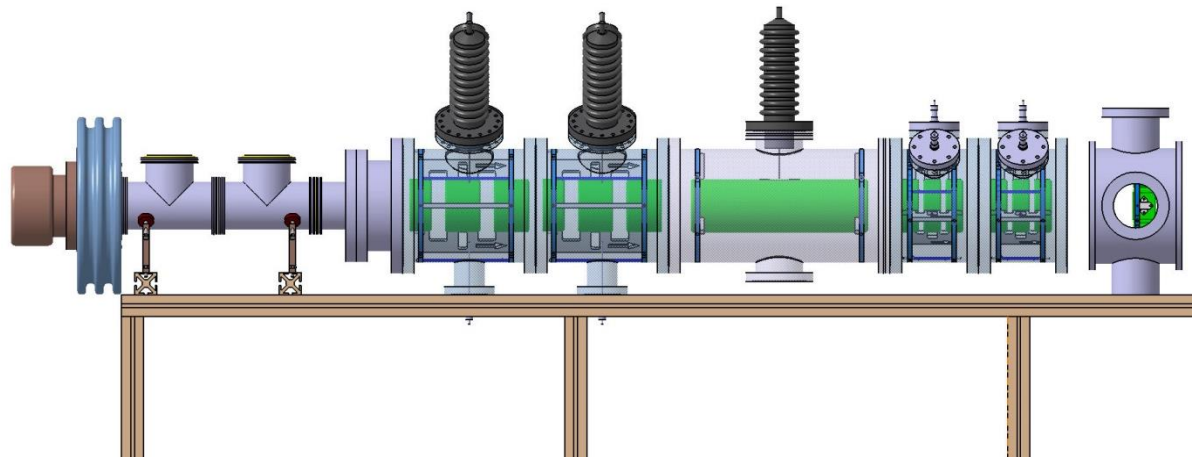

Choice of the positron source

- Low energy (~ 50 eV, ~ 1 -2 eV FWHM, ~ 10 mm diameter in ~ 8 mT guiding magnetic field)
- High intensity
- Can be installed in the experimental zone of GBAR (size, radiation protection)

Most often used

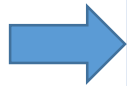

	+	-
Na-22 isotope	Commercially available	Intensity is limited ($\sim 10^7$ positrons/s)
Other isotope	High intensity possible	Short living isotopes, access to accelerator or reactor is needed
Reactor	High intensity possible (10^9 e ⁺ /s in Munich)	Expensive, fixed, limited access
Accelerator	Can be compact, high intensity is possible	Large biological shield

Choice: small, compact, water cooled (RT) linac

Some linac-based slow positron sources from the 1980's

LLNL
100 MeV
>10⁹ e+/s

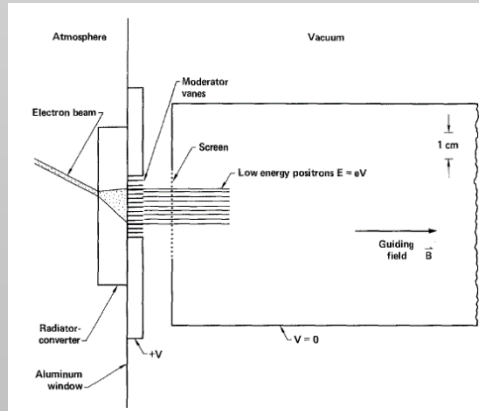

Tokyo
25 MeV, 1μs, 100 Hz,
150 mA peak
2x10⁶ e+/s

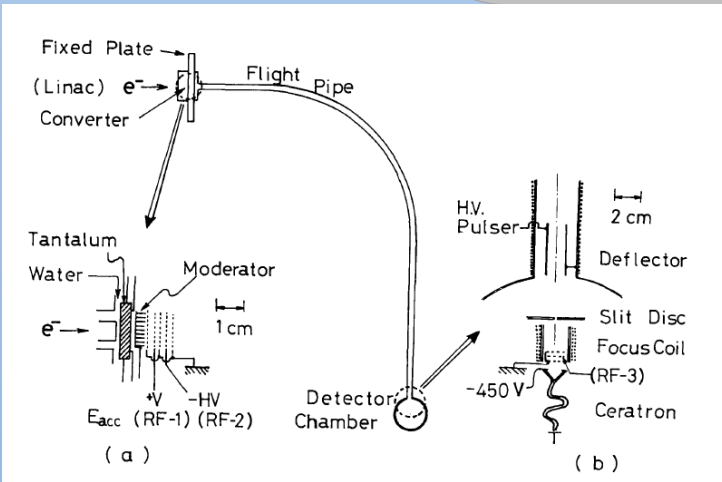

Giessen
35 MeV 100μA
avg.
1.5x10⁷ e+/s

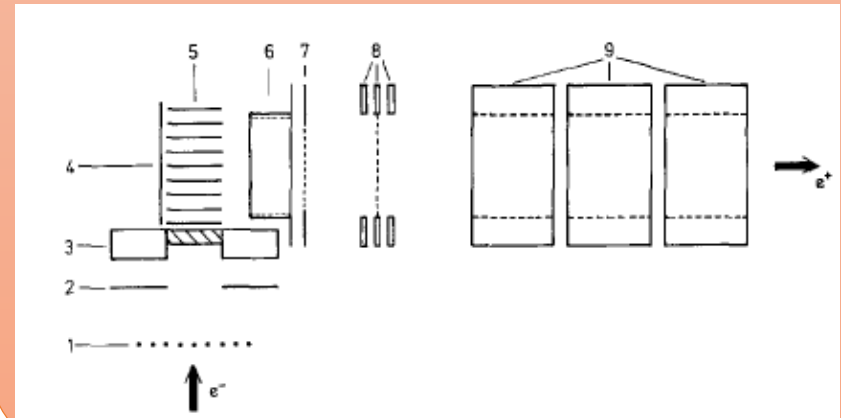

Positron generation using a 9 MeV linac

- Low electron energy
- No persistent activation (although some short-lived radioisotopes are produced)
- Compact, quick access to the target zone
- Simple target geometry, optimized moderator

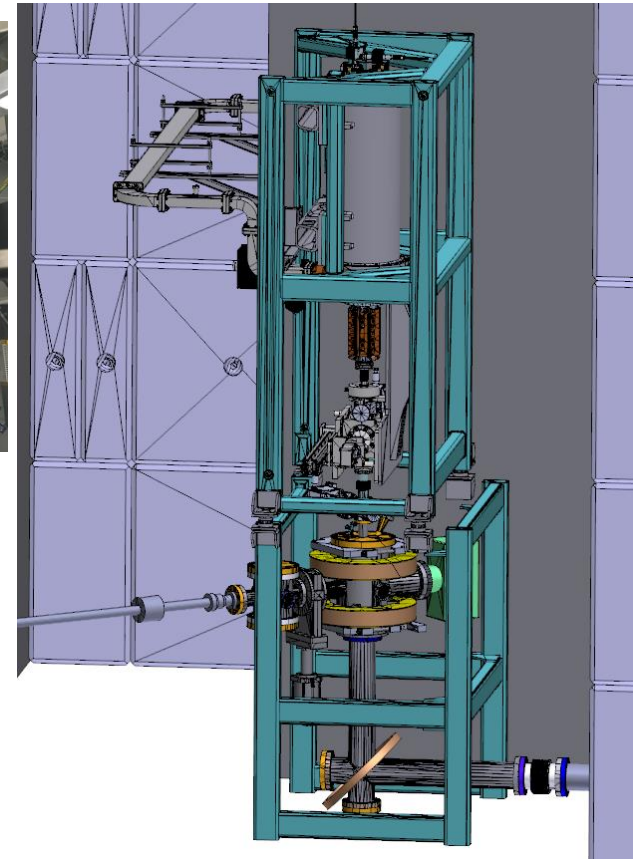

Linac properties:

Energy ~ 9 MeV

3 GHz klystron

Repetition rate 300 Hz

Pulse length $3 \mu\text{s}$

Peak current 300 mA

Average current $270 \mu\text{A}$

(Beam power $\sim 2400\text{W}$)

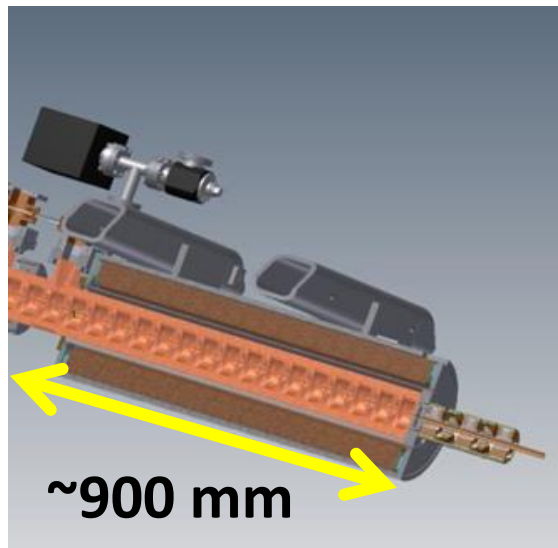

Slow positron production: electron target and positron moderator

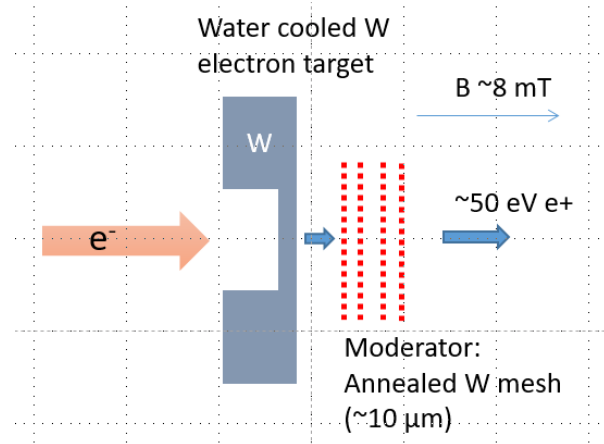

1 mm W electron target + stacked W mesh moderator ($25 \mu\text{m}$; annealed at $\sim 2500 \text{ }^\circ\text{C}$):

- $\sim 4 \times 10^7$ slow positrons/s at 100 Hz linac freq. (September 2018)
- $\sim 10^8$ slow positrons/s expected at full power (end of 2018)

- Positron moderator: re-emission of slow ($\sim \text{eV}$) positrons (materials with negative positron work function – W, Pt, Ni, Cu, SiC, Ne...)
- Near-surface effect – only positrons within $\sim 200 \text{ nm}$ from the surface
- Typically $10^{-4} - 10^{-3}$ efficiency for well annealed tungsten, 10^{-2} for solid Ne (7 K)

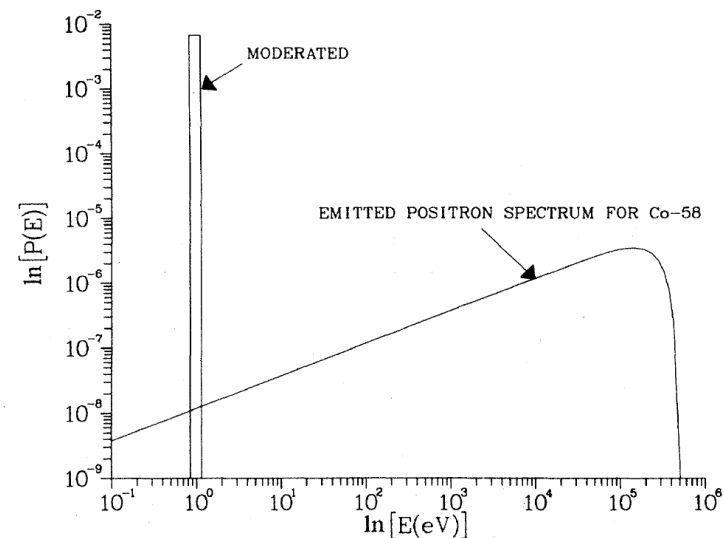

The slow positron beam at Saclay (CEA/IRFU)

Beam switch/user port
(materials science)

Slow positron drift tube
(~10 eV)

Penning trap for e⁺
(RIKEN)

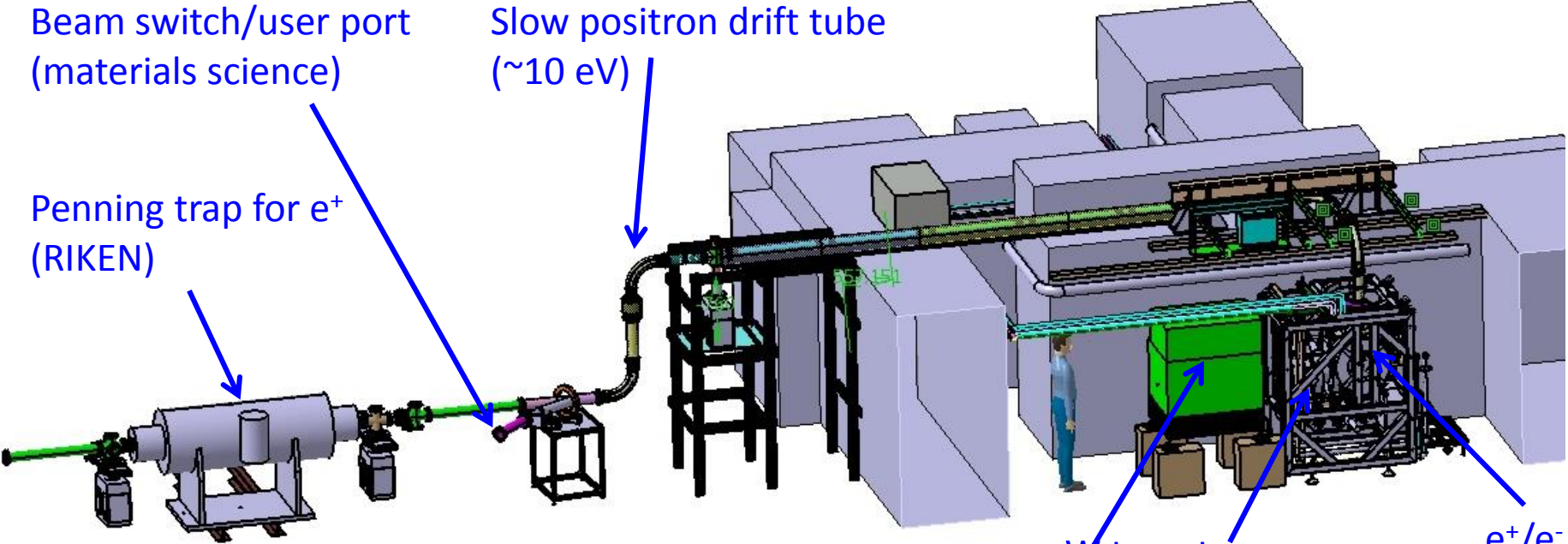

e⁻ linac
(4.3 MeV)

Slow e ⁺ rate	$3 \times 10^6 \text{ s}^{-1}$
--------------------------	--------------------------------

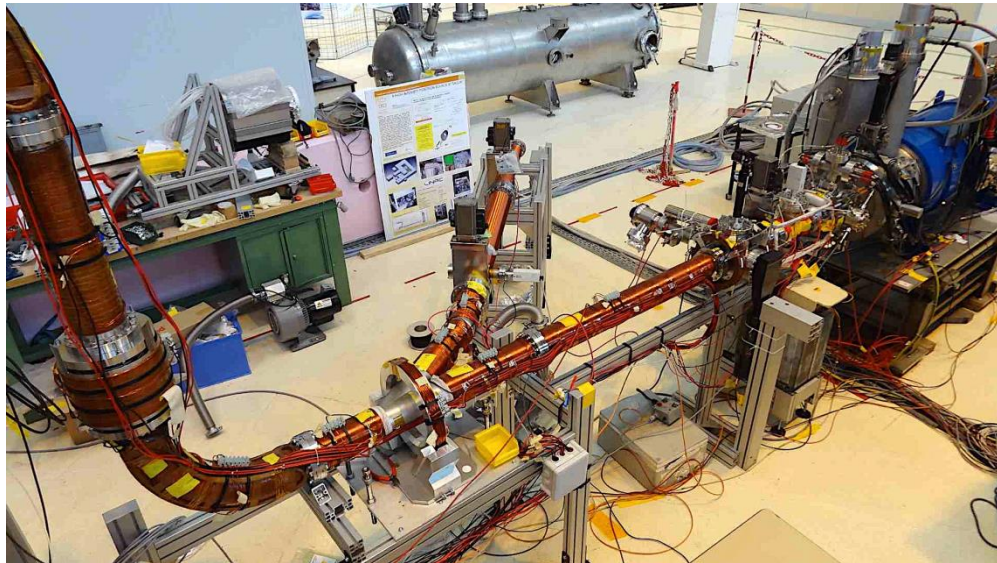

Buffer gas trap

- « Surko trap » to capture and trap e^+ (few seconds)
- Nitrogen (1st stage) + CO_2 (2nd stage)
- Short term accumulation (3rd stage)
- $\sim 9\%$ efficiency at present, work in progress

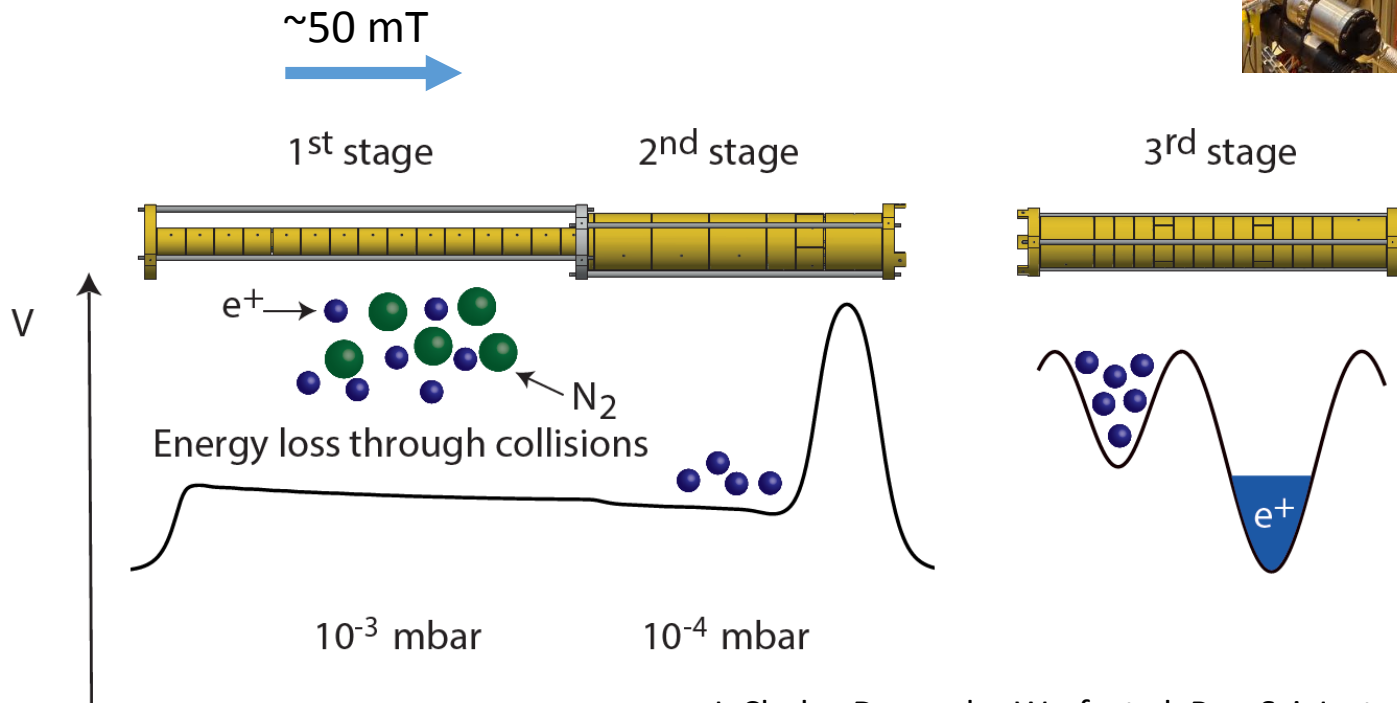
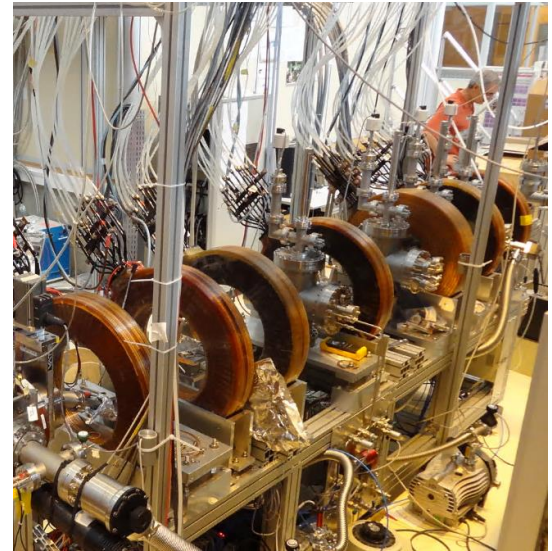

Positron accumulator

- 5 T magnetic field
- Multiring trap
- Cyclotron cooling
- Deep (kV) parabolic trapping potential
- Up to a few 10^{10} positrons between the antiproton pulses (~108 s)

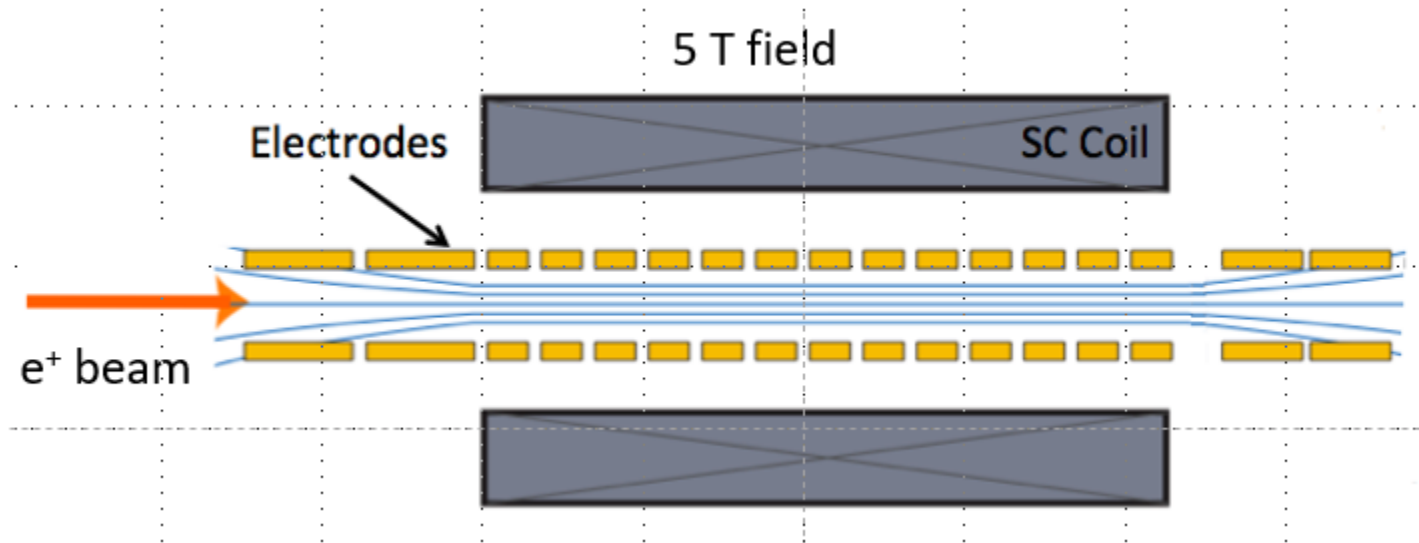

Positronium production

- Triplet (ortho-Ps, $\tau = 142$ ns) and singlet (para-Ps, $\tau = 125$ ps)
- Only ortho-positronium is useful
- ~30 % conversion efficiency
- ~50 meV o-Ps energy

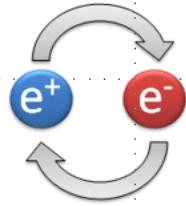

Positron-positronium converter
(mesoporous SiO_2)

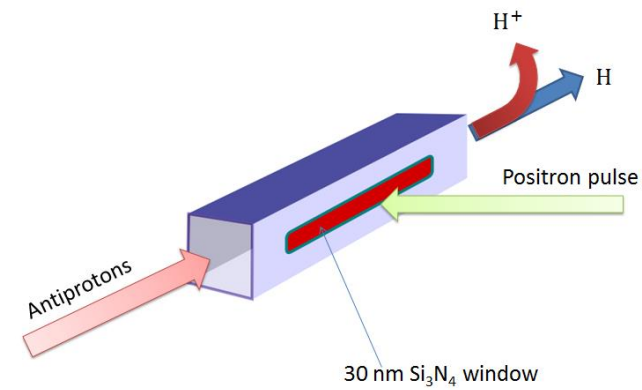
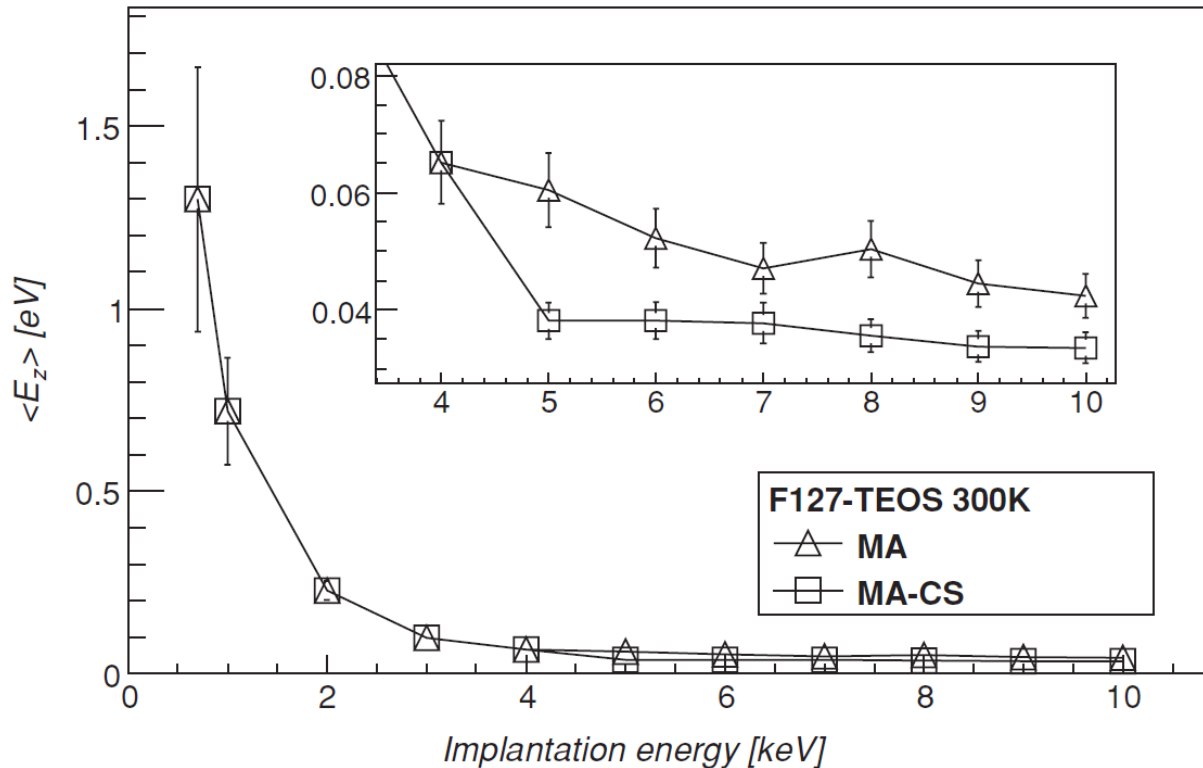
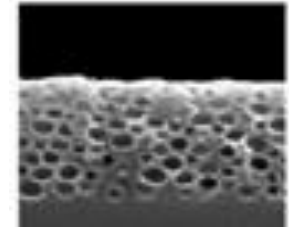
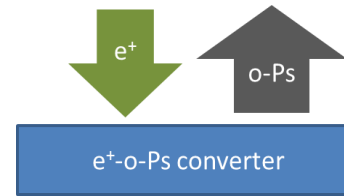

Optical excitation of Ps

3D - 410 nm Doppler-free

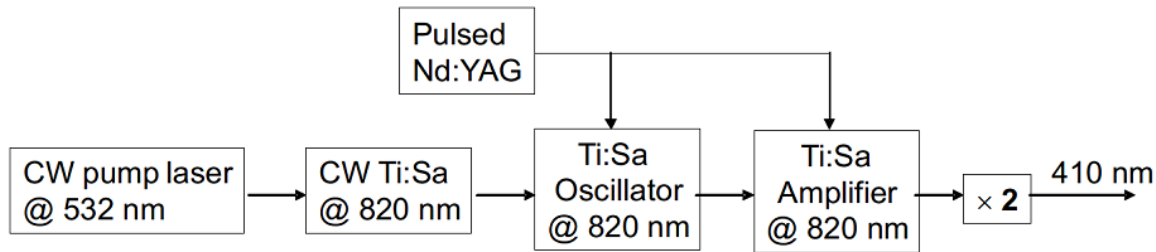

2P - 243 nm frequency comb

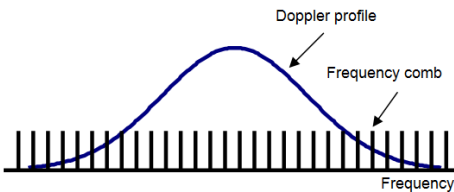
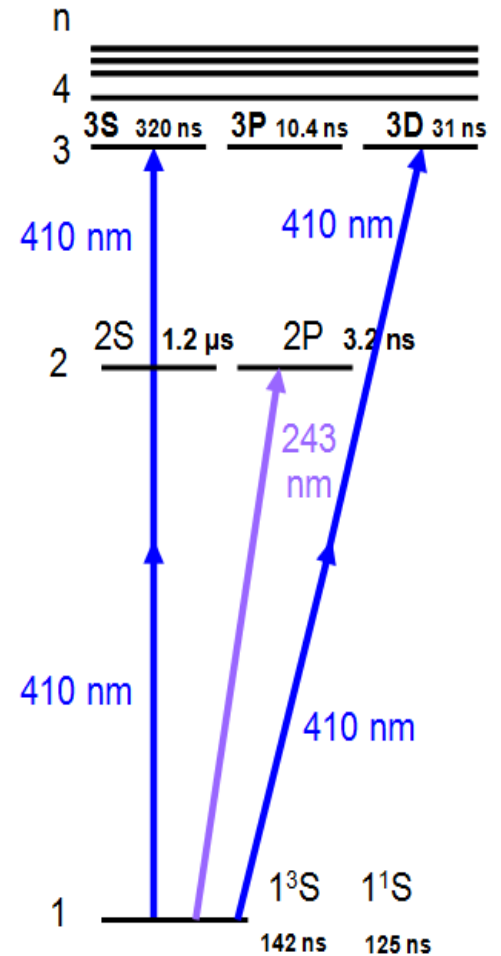
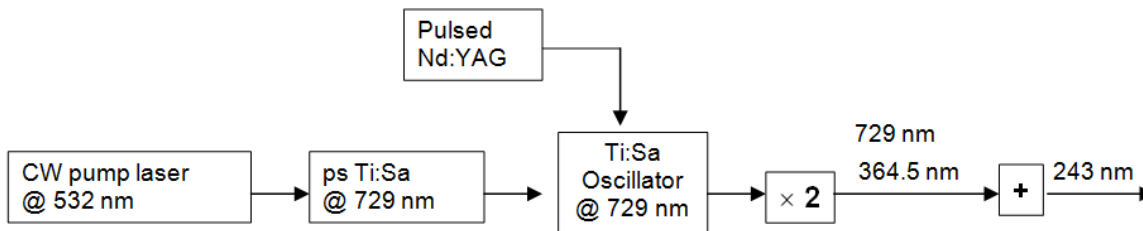

Anti-ion cooling, step 1: sympathetic cooling in a Paul trap

- Very high mass difference - difficulties in cooling
- Improved scheme using HD^+ ions as intermediary

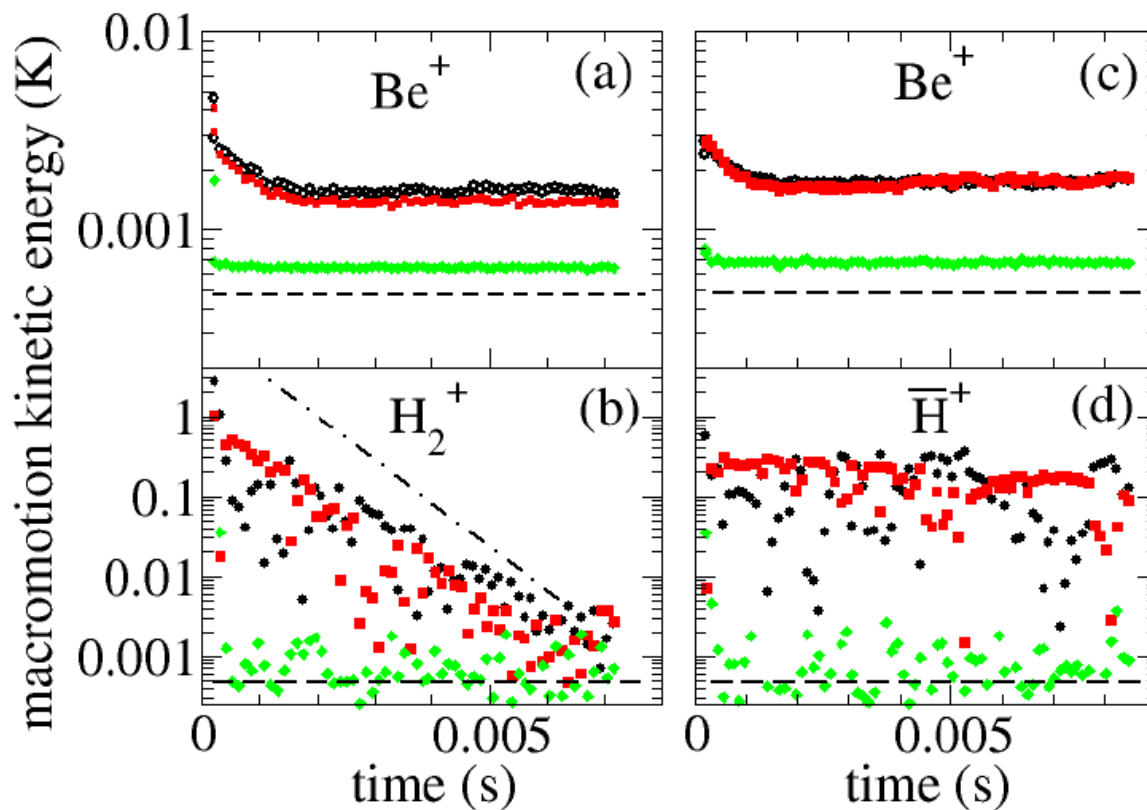
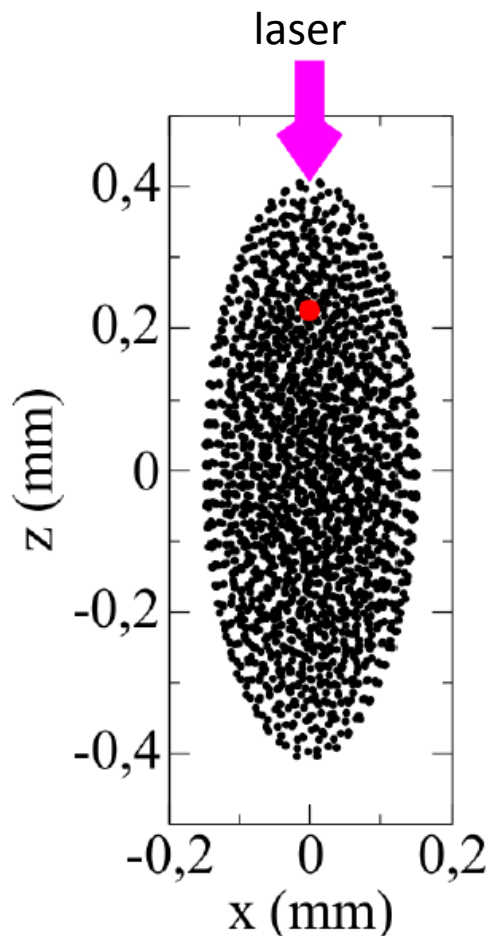
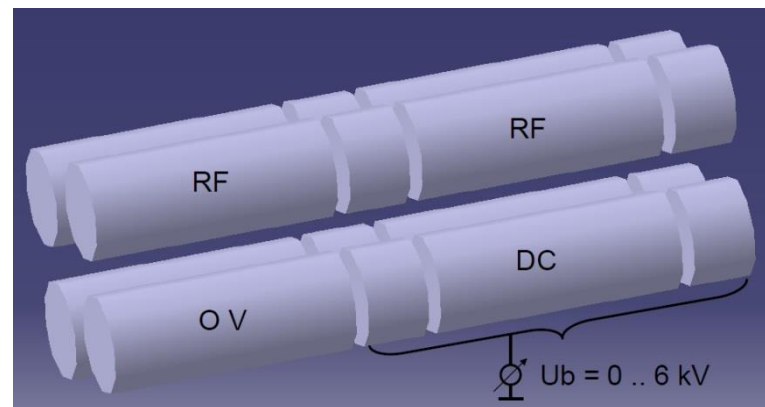

Anti-ion cooling, step 2: Raman sideband cooling in a precision trap

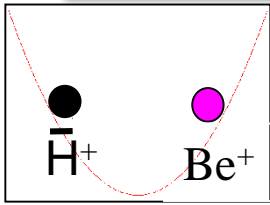

Cooling through a sequence of stimulated and spontaneous Raman transitions

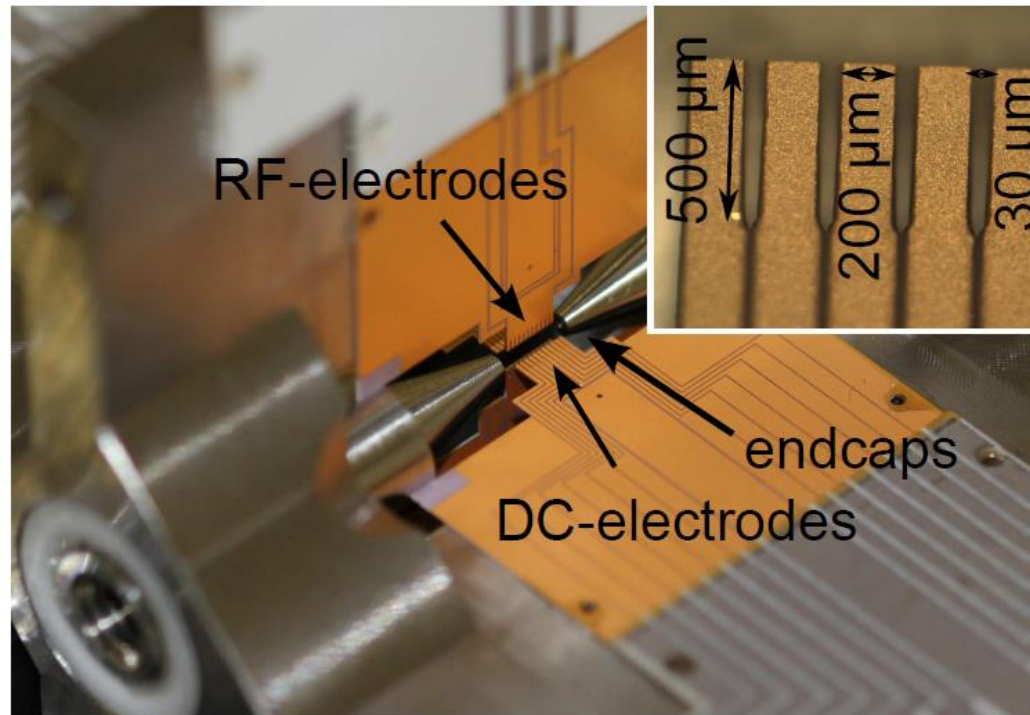
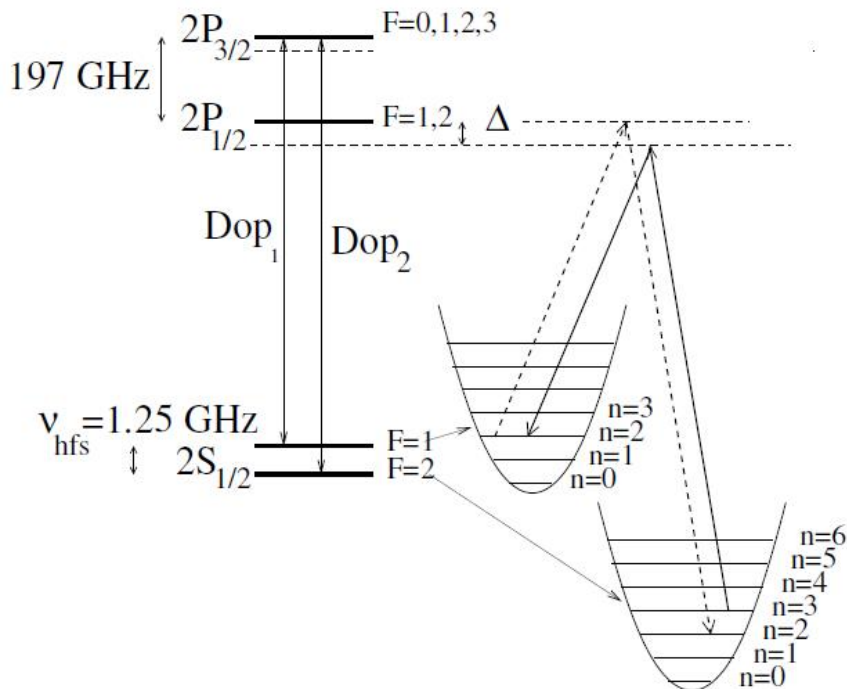

(F. Schmidt-Kaler, Univ. Mainz)

Present status

- System is assembled up to to reaction chamber
- ELENA (antiproton deceleration to 100 keV) works but needs further improvements
- Beamtime for GBAR since August 2018
- We are working on the switched decelerator
- Positron source works, final commissioning was delayed until the end of 2018
- Positron traps are being tuned

Outlook

- Antiproton beam until November, then no beam for 2 years (LS2)
- We will use the time to improve positron production and trapping & test reaction with proton beam
- Antiproton trap to improve pulse quality

The GBAR collaboration



P.N. Lebedev Physical Institute of the Russian Academy of Science



서울대학교
SEOUL NATIONAL UNIVERSITY



UPPSALA
UNIVERSITET



Thank you



The GBAR experimental setup at CERN

