

ATC-ABOC 24th Jan-2007

Summary of session 6

Experimental areas and CNGS

- I. Efthymiopoulos Introduction
- K. Cornelis Operations
- V. Baggiolini SPS EA Renovation: Status and Outlook
- W. Kalbreier Magnets: PS East + SPS North Area
- Y. Gaillard Power converters of the SPS and PS EAs
- R. Nunes EA Access Systems: 2007 and beyond
- E. Gschwendtner CNGS: Status and Outlook
- C. Rembser Outlook on (future) physics program

I.Efthymiopoulos: Introduction to North and East Areas and CNGS



Operations in 2006 - Highlights

- The **Very Low Energy beam** of H2 was fully exploited by **CMS**
 - Beam tunes for calorimeter calibration from **1÷350 GeV/c**

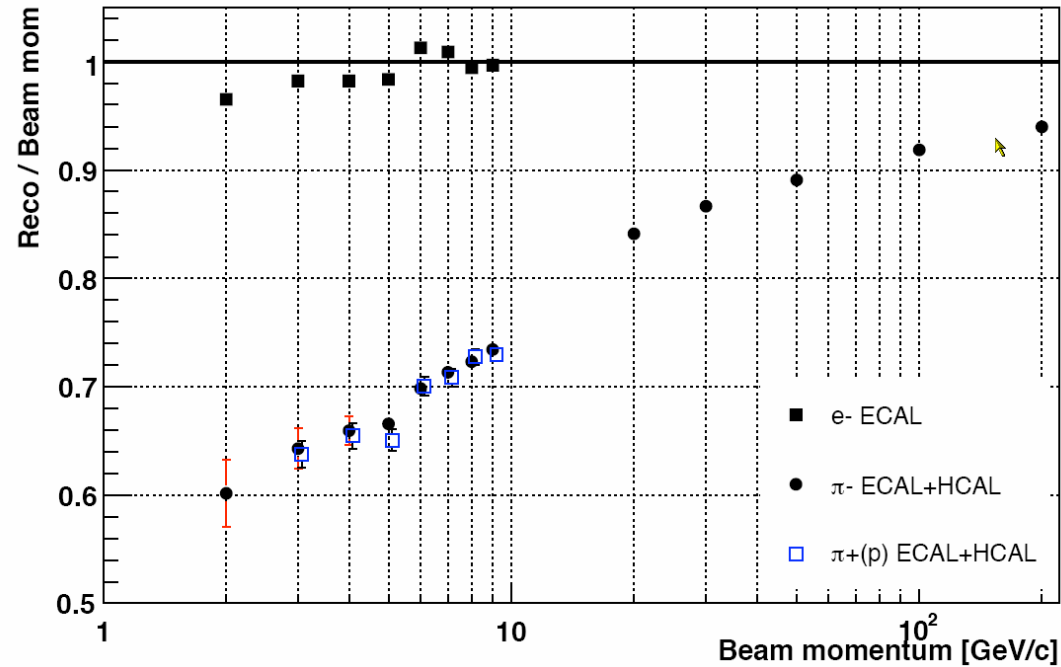

- Successful test for **LHCb-VELO** in H8
 - Validation of final detector module before installation

- Exciting results from the bend **crystal test in H8**
 - Volume reflection with high efficiency at high energies verified
 - Although the full potential of the beam was not exploited

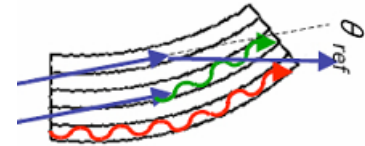

- Impressive work and results for the **ILC detector R&D teams**
 - Newcomers to CERN; decision pending for long term usage of the test beams at CERN (competition with FermiLab...)
- Modifications done in TCC2 and M2 line during the 2005 shutdown allowed to increase the beam intensity for **COMPASS** by 15% → **1.40×10^{13} protons/extraction on T6 (16.8 sec sc)**
- **CLOUD** completed successfully the first commissioning run in T11 line

Operations in 2006 - Statistics

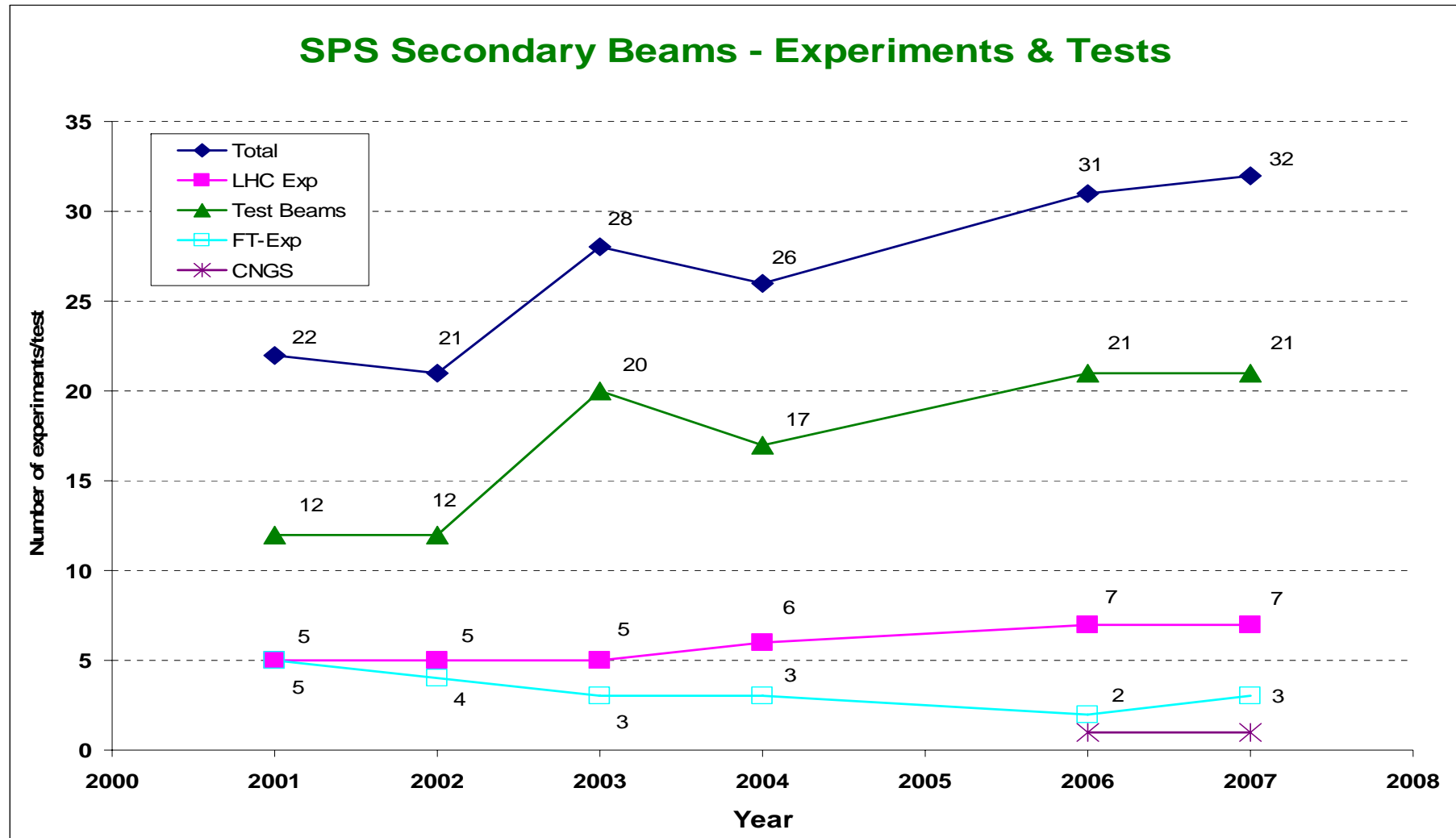

- Most of the small experiments are scheduled in weekly slots
- Try to satisfy more requests
 - WA not available anymore...
 - Budget constraints (travel,...) for the users limit their stay at CERN
- Fully exploit the possibilities in the exp. halls
 - multiple exp. areas per beam line
 - parasitic users

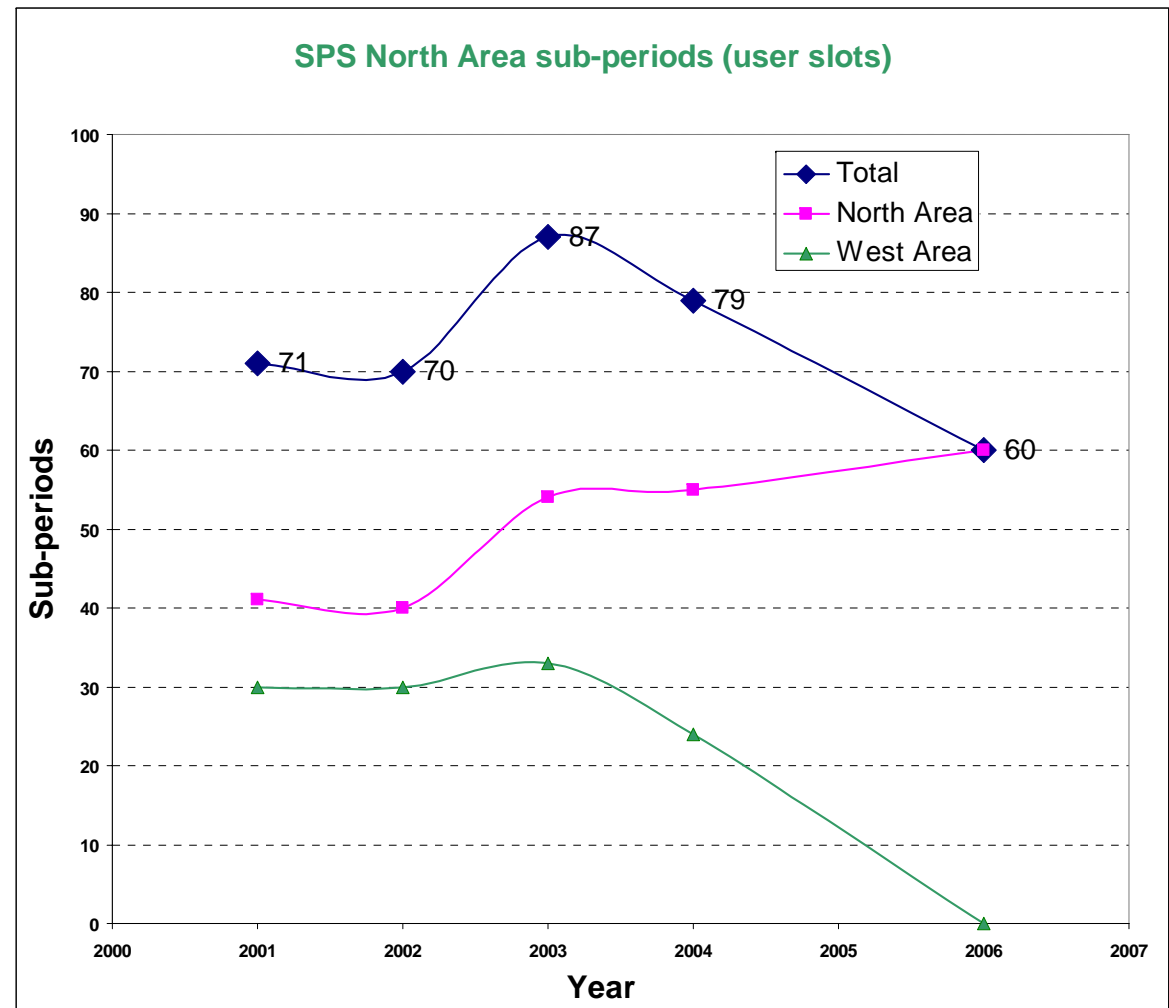

- ❑ **North Area** instrumentation and controls renovation went well, but incomplete. **To be fully completed.**
- ❑ The commissioning period with beam was very useful.
To be scheduled at every start-up.
Request for scheduled Beam Development slots (2 x 8 hrs per beam)
- ❑ Number of beam requests for NA rising steadily,
2 major changes of installation per week on average.
Majority of users achieve most of their goals
- ❑ **East Area** downtime dominated by F61S.BHZ01. **Replace by MCB for 2007.**
- ❑ **Long Flat Top** very useful for e.g. COMPASS
- ❑ Some additional features in Cesar would ease operation,
some equipment and software still to be renovated. (Extend to East Area?)
Implement missing equipment and features
- ❑ Some safety improvements needed around EHN1: **Implement** fences, cleaning.
- ❑ **CNGS** went well until hit by water leak on reflector
- ❑ Manpower decreasing in AB and support groups.

Introduction

Comments - Questions

- Consolidation threshold: If planned consolidation activities are dropped or delayed (i.e. lacking manpower) Consolidation of low Risk-factor items (i.e. experimental areas) is an alternative spending, (S.Baird).

Define consolidation items.

- There is missing manpower in the radioprotection group (D.Forkel).

Include constraints in planning.

- In order to adapt to new RP regulations, some of the areas must be reorganized and detailed measurements must be done (D.Forkel).
Some new shielding must most likely be added in several places

K.Cornelis: Operations of North and East Areas and CNGS

Impact of NA on operations (seen from the logbook)

~1 Action / shift

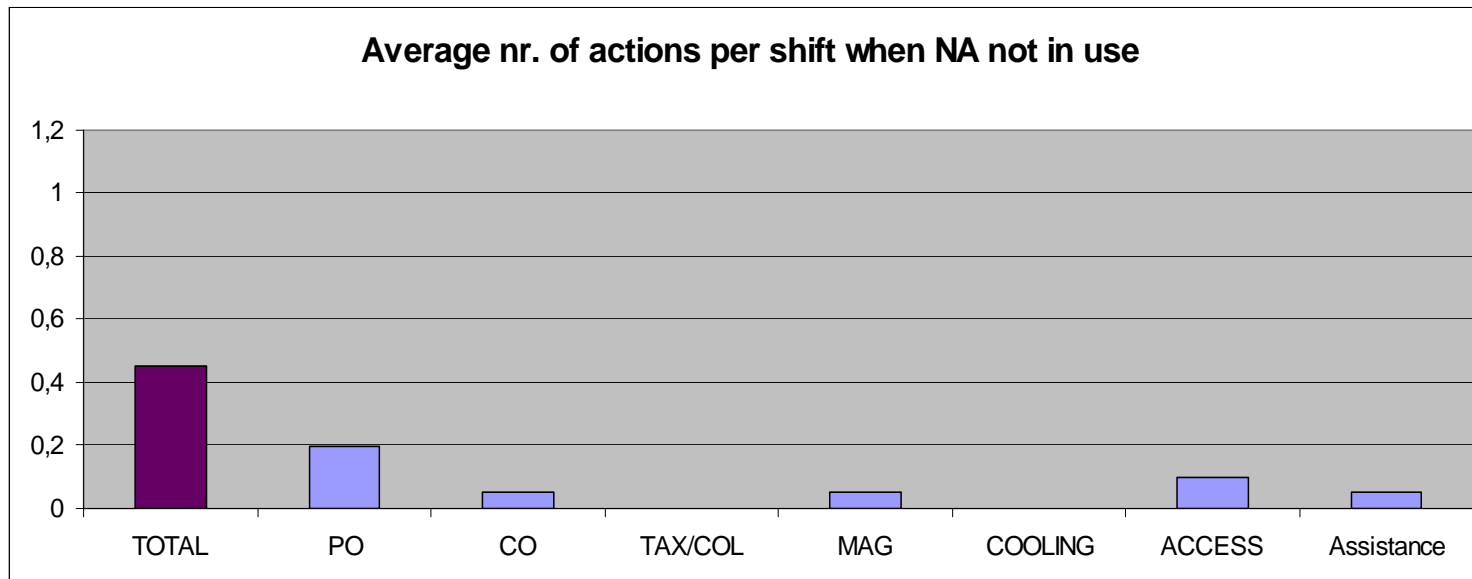
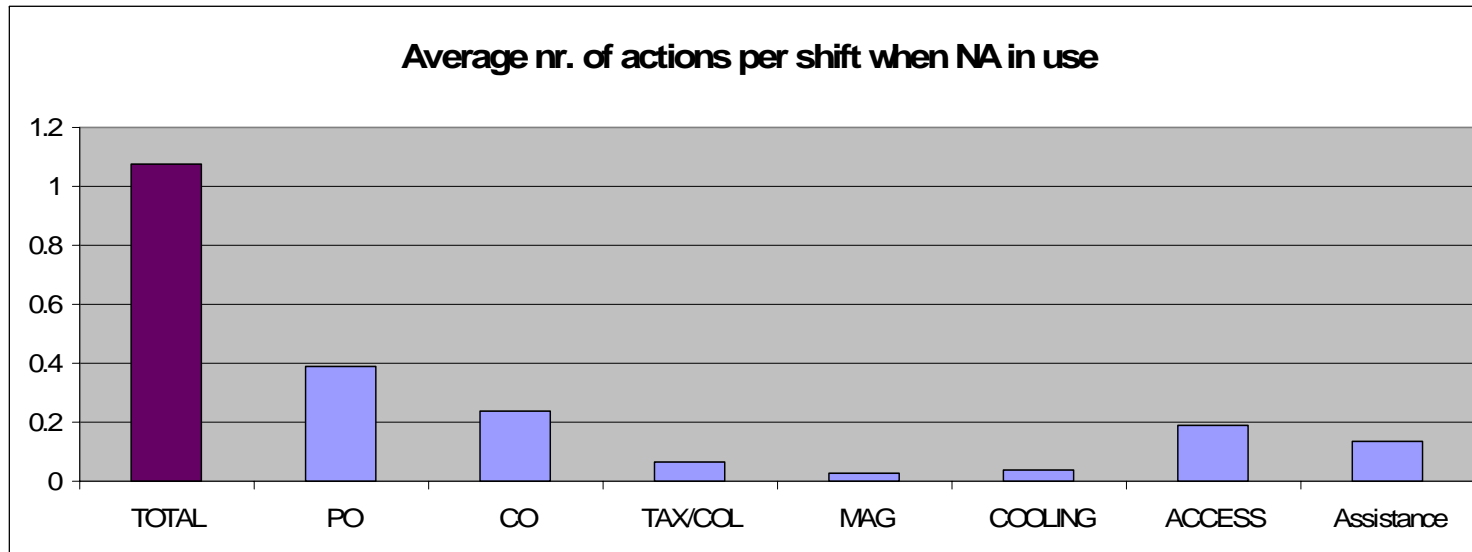

- ❑ **East Area:** handling of technical problems only, beams operated by users
- ❑ **North Area:** also setting up and changes of beam conditions
Communication with users and EA physicists must be further improved, operators lack knowledge of North Area. So do the users sometimes.
The Support from EA physicists is essential.
- ❑ Frequent schedule changes (in between meetings) and sudden changes of requests
- ❑ Stability problems in TT20. Autopilot is of great help.
- ❑ **CNGS** operations is stable, but rely on good diagnostics and monitoring
- ❑ Heavy RP involvement in access procedures, in particular for TT20 and CNGS
- ❑ Good tools are essential to do more work with less people

Operations

Comments - Questions

- *SPS competence is drifting away to LHC*
 - **Improve training, to be added in MAPS**
- *Main difficulties and peak load occur after MD.*
More operators can be provided at those times in 2007, but not after.
Can we schedule peak load EA-operator presence once per week?
- *There is a non-negligible load from Experimental areas on Operation outside beam periods , e.g. during MD's or stops: access, magnet or supply interventions, timing, ..*

V.Baggiolini: SPS Experimental Areas Renovation: Status and Outlook

SPS North Area

- 7 beamlines
- 3 experimental halls
- ~20 test facilities
- 5.8km of beamlines
- ~1000 pieces of equipment

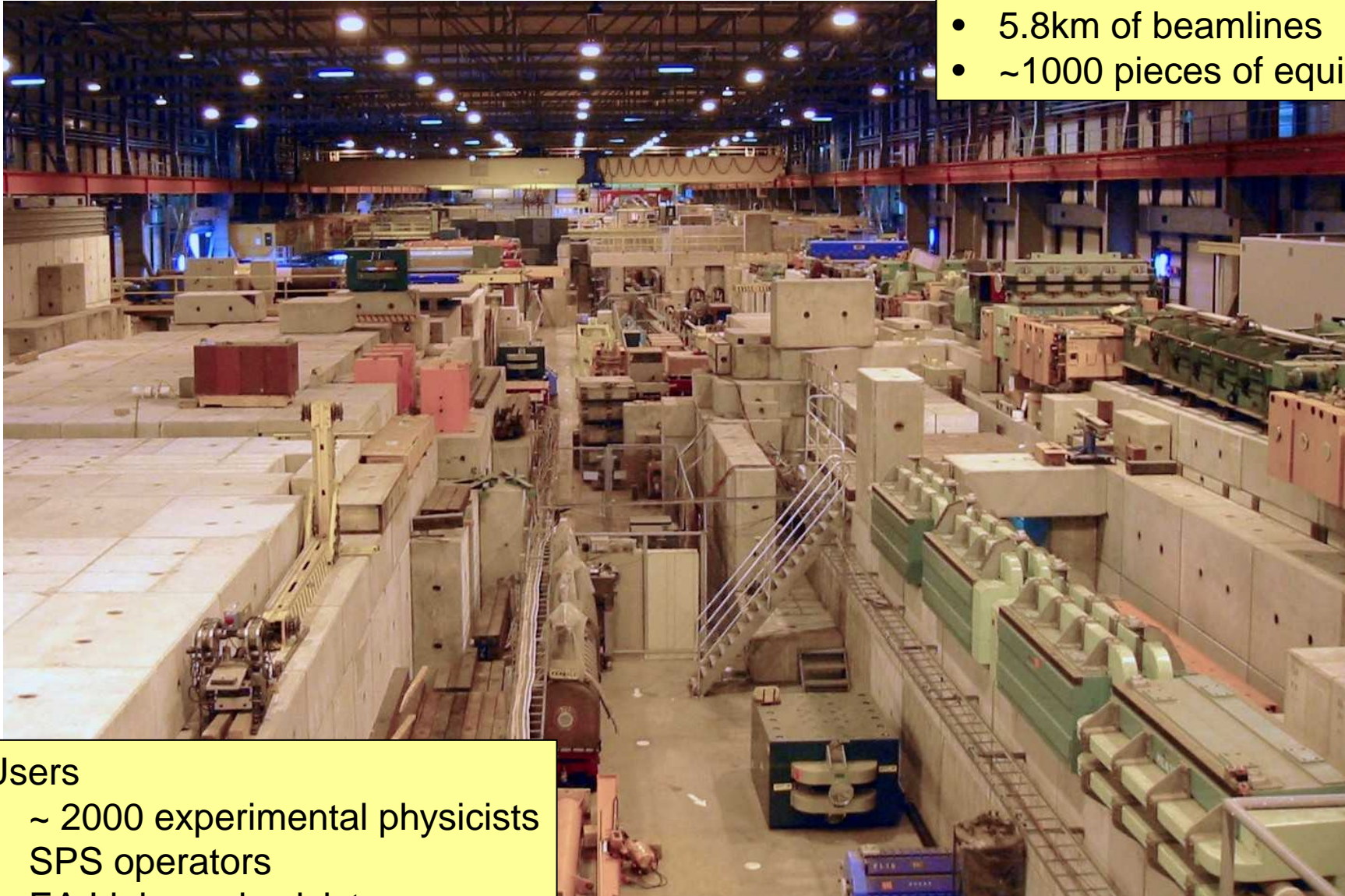

Users

- ~ 2000 experimental physicists
- SPS operators
- EA Liaison physicists

Resource planning

- Items necessary for Run 2007
 - Debug + fix low-level controls of positioning motors (1-3 man-months)
 - Finish renovation of controls chain to zone access system (AB: 2 mm)
 - Finish CEDAR and XEMC + developments in CESAR (6-8 mm)
- CESAR items that make operations more efficient / less error prone
 - Show only settings (beamfiles) which match active Wobbling config. (2mm)
 - Facility to document “golden” beamline settings (both steering elements + instrumentation) as reference for OP → E-Logbook? (0mm)
 - Support for EA physicists to adapt settings when layout changes (3mm)
 - Better printing support for long status GUIs (1mm)
- Work which needs to be done “sooner or later”
 - Replacement of an obsolete user interface library (Netbeans) (~ 6mm)
 - 2008: Renovate last two instruments + adapt CESAR
 - Renovation of positioning motors (hand over BI → ATB)
 - Many minor things to really finish the renovation project

Legend: **organized and staffed** – to be organized and/or staffed – **potential problem**

- ❑ A good job has been done, but there is still work to do
- ❑ Hardware renovation mostly completed. Remains **XCED** and **XEMC** for 2007 and the migration of positioning motors and analog chambers
- ❑ Software has been operational, but some functionality still missing to allow for easier and more efficient operation.
Teething problems of new devices have largely been solved, but reliability problems with some non-renovated devices (EQ-bus).

Manpower?

Some work is urgently needed there.

- ❑ EA work is competing for resources with LHC, but there are synergies with LHC standards. Areas serve the LHC experiments!

SPS EA Renovation: Status and Outlook

Comments - Questions

- East Area still suffers from not having beam loss monitoring for the primary beams. First asked for in 1998, but not foreseen in manpower plan.
- East Area controls renovation, add instrumentation?
- **Action: Global review of East Area**

W.Kalbreier: Experimental Areas magnets

BREAKDOWNS DURING OPERATION PER YEAR

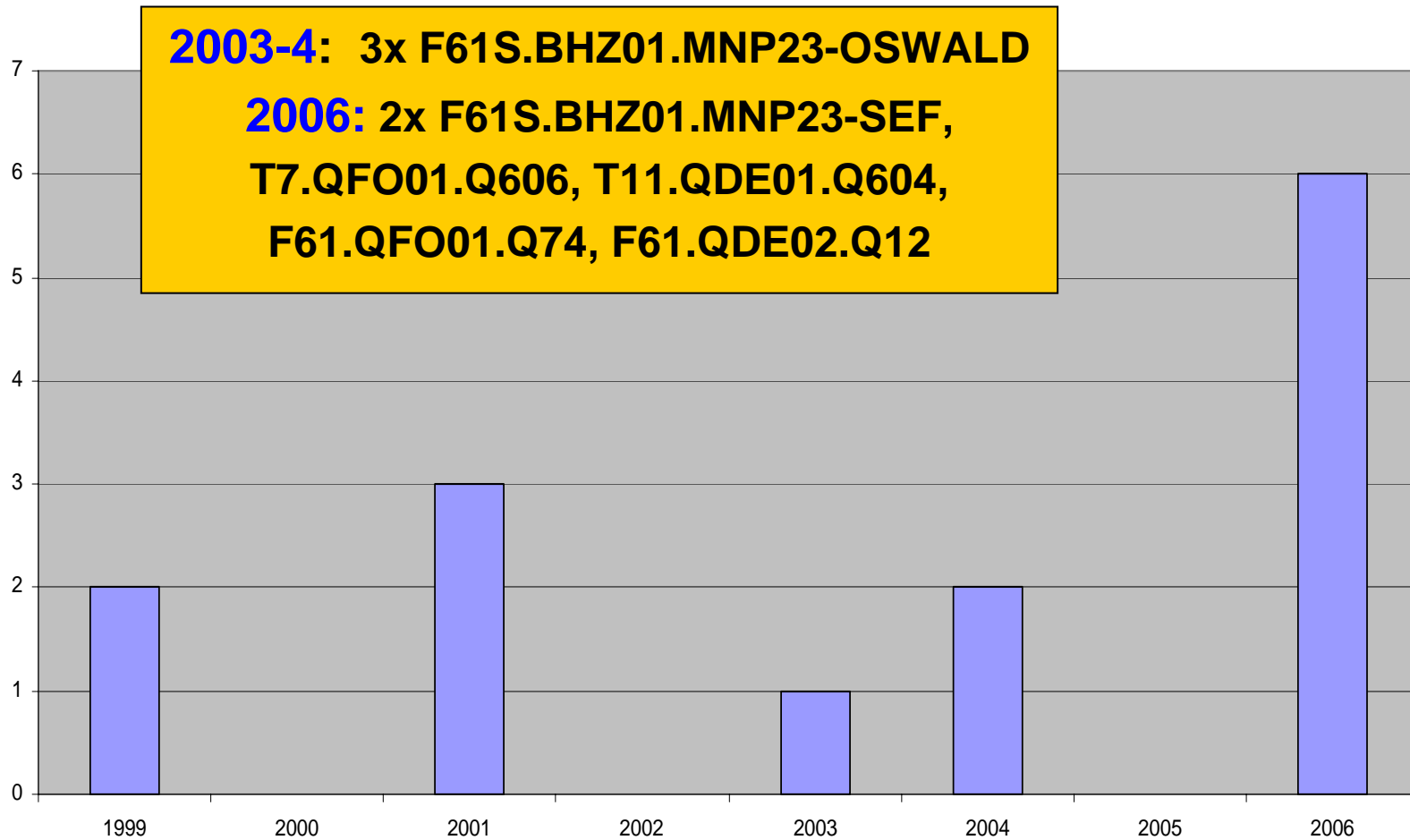

Horror Gallery

F61S. BHZ01.MNP23 10-2006 breakdown 3rd coil SEF

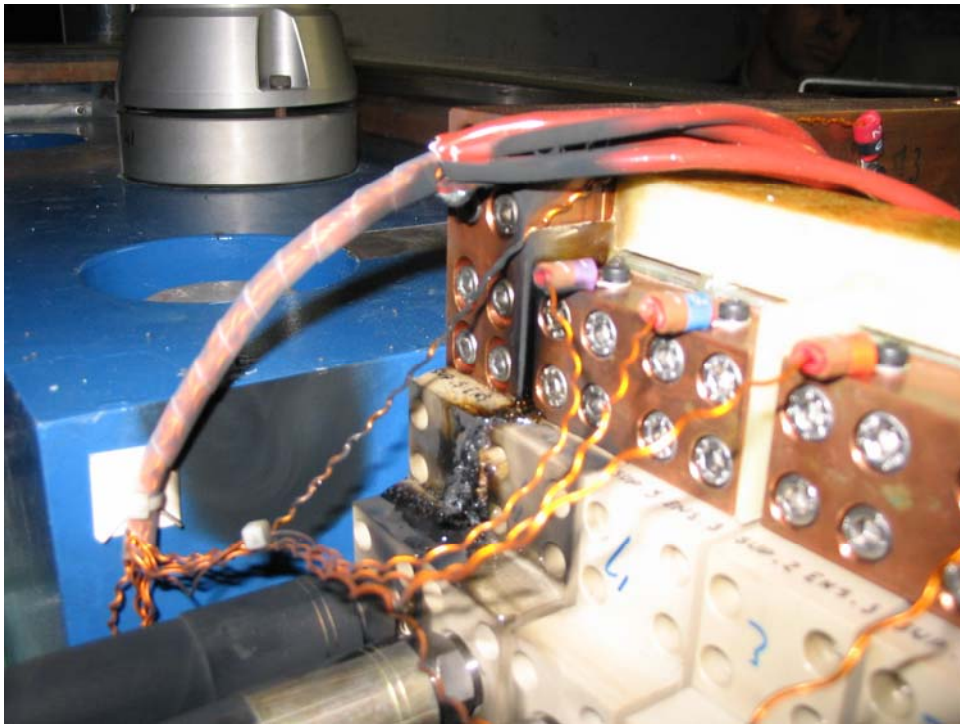

'Weak' magnets:

Q800



Q600

Accessibility:



22 types of East Hall Magnets: in operation & spares as per January 2007

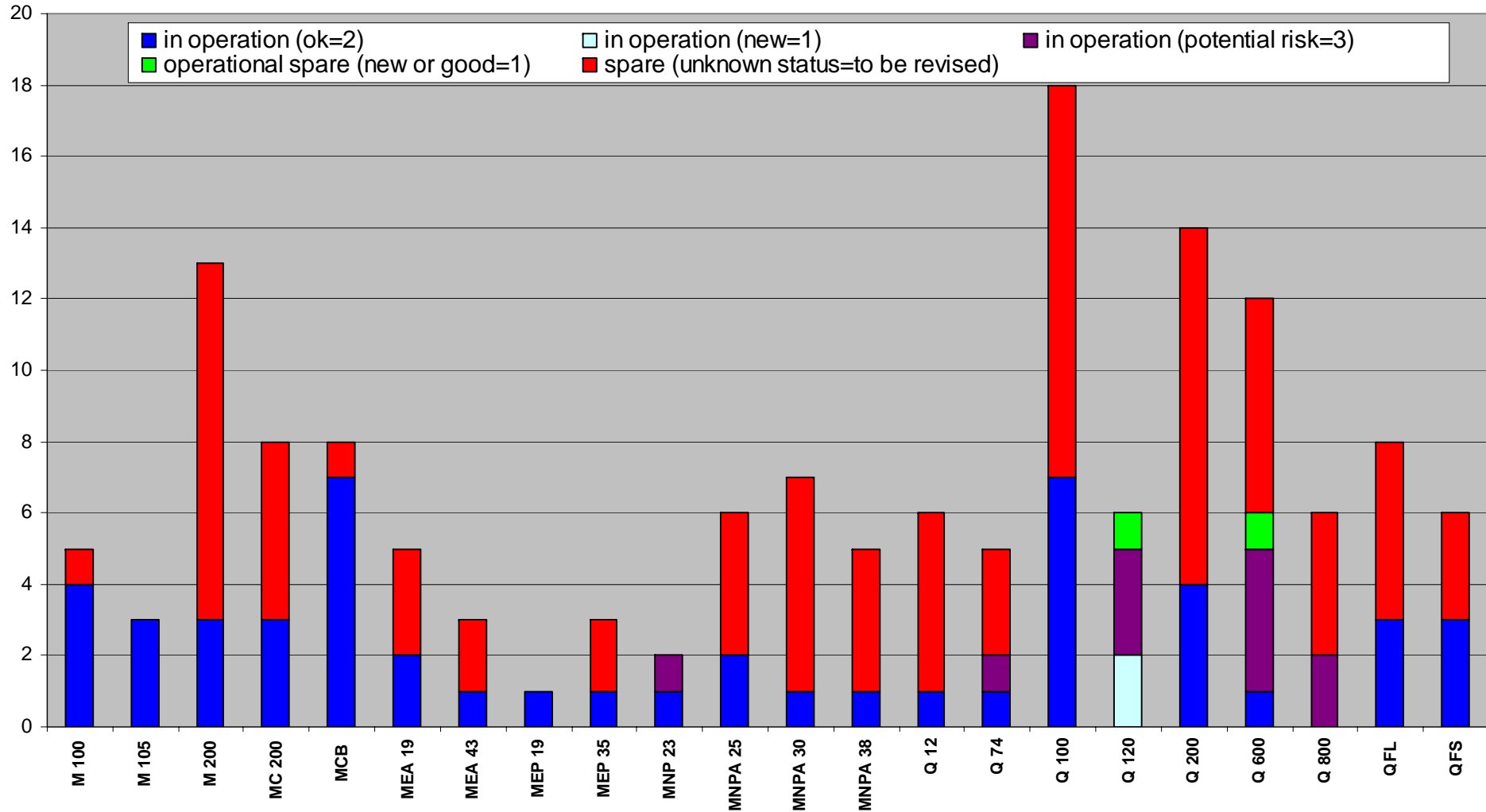

East hall primary zone: (Access possible during PS operation)

Extremely densely packed + covered with concrete shielding roof → for any magnet replacement an opening + closing takes 2 weeks + cool-down + magnet exchange period

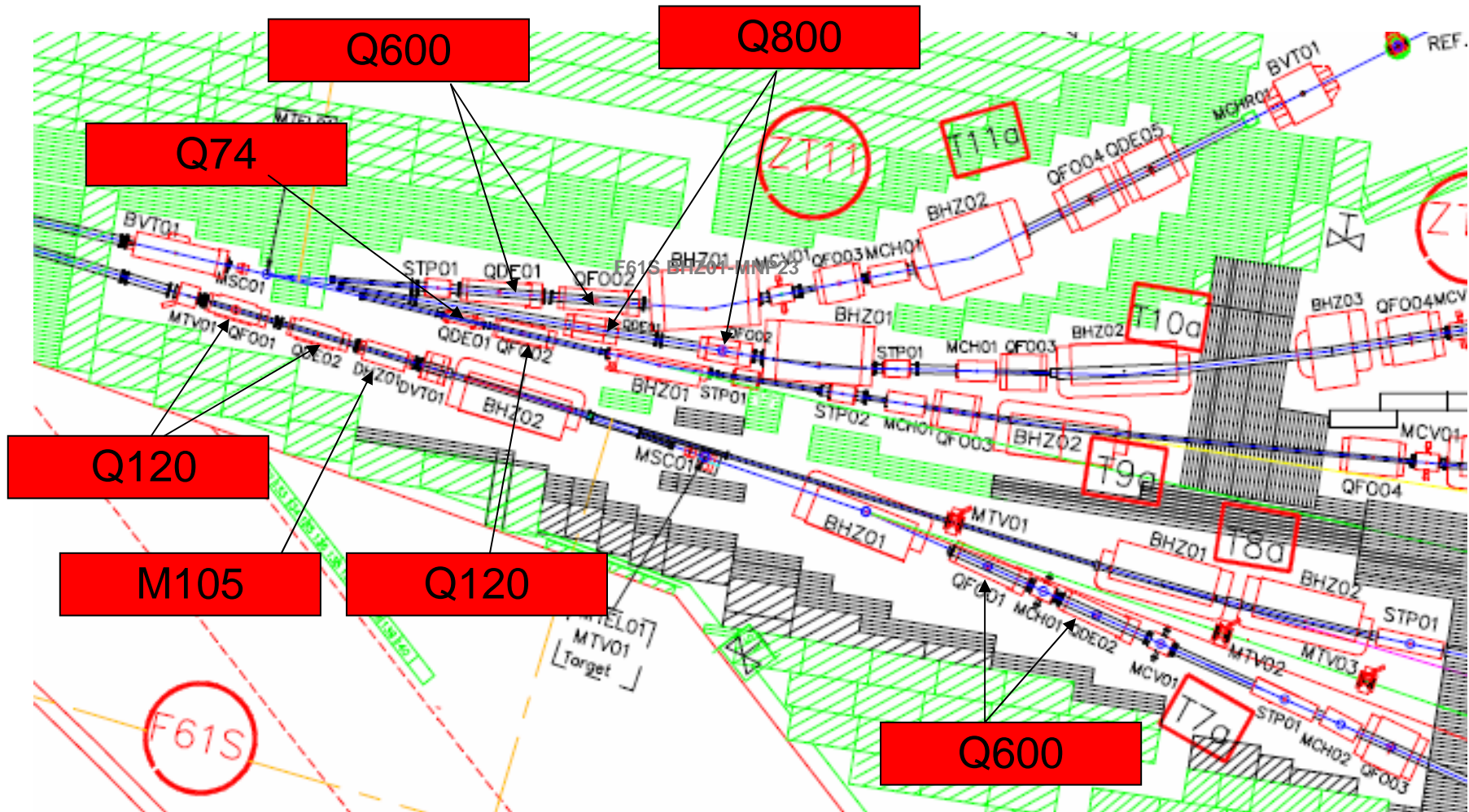

Magnet Status for the primary Beam Transfer

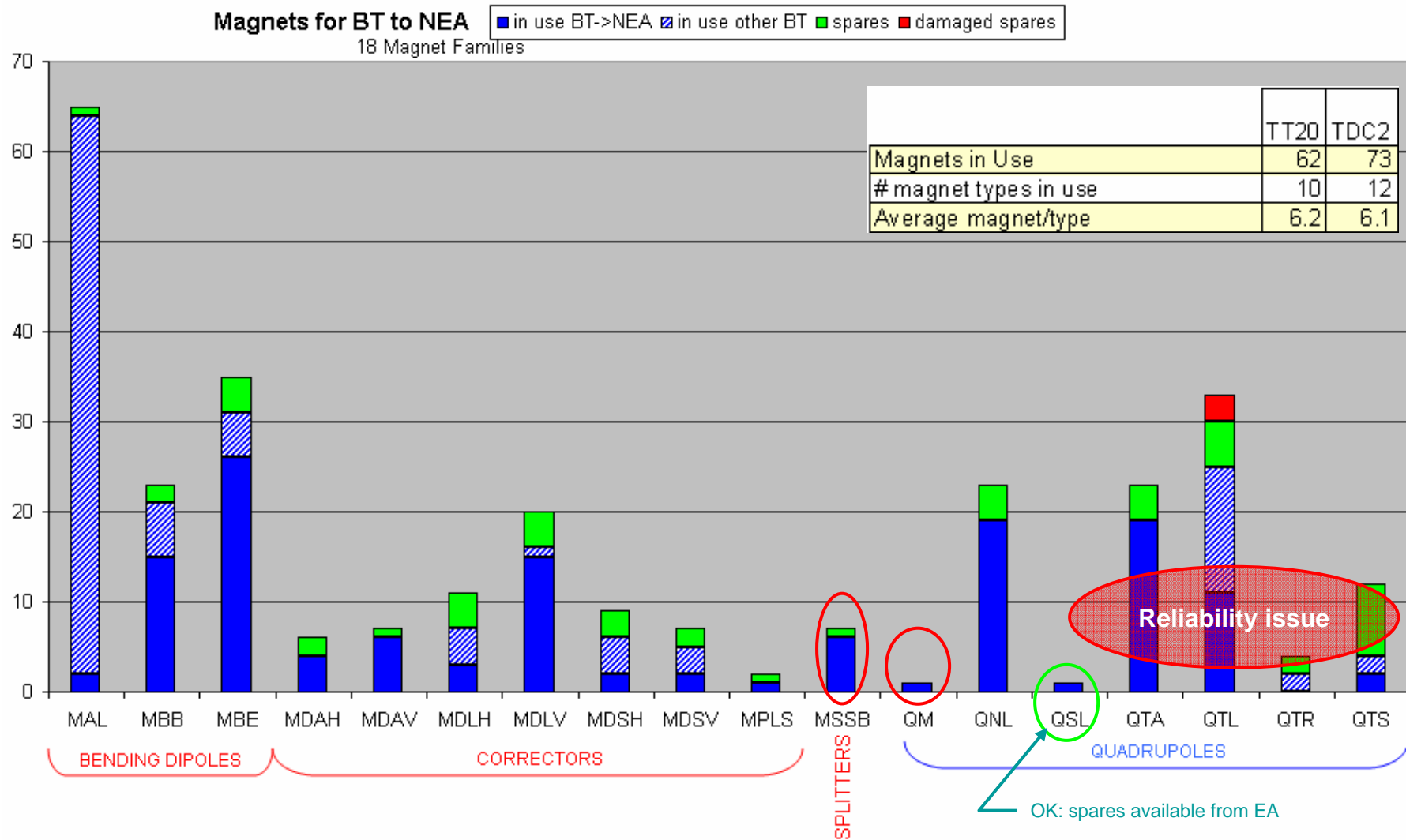

Magnet status for the NEA & secondary Beams

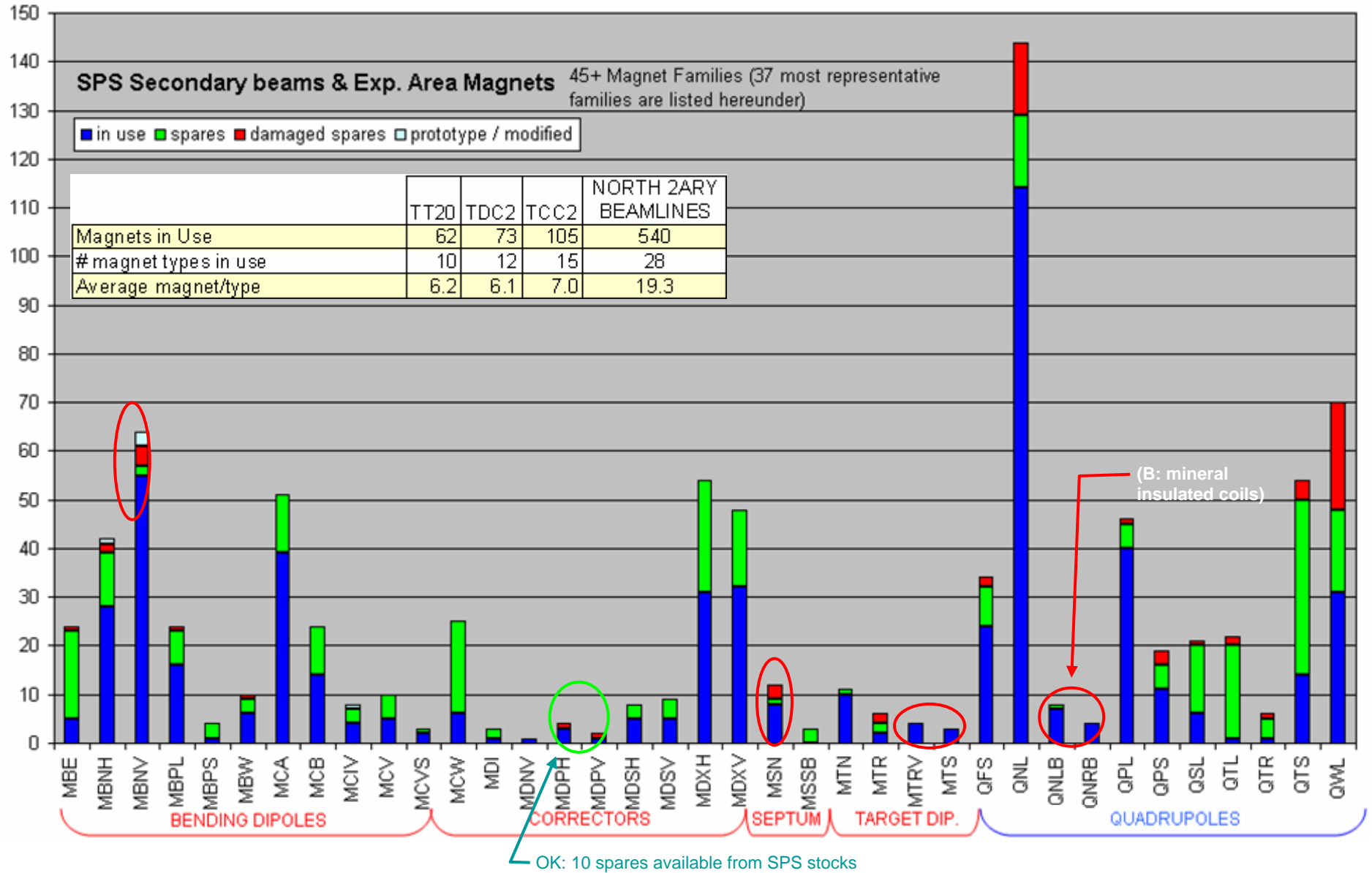

- East Area: 63 magnets installed of 22 different types.

Represent 8% of #NA magnets but require same amount of FTE!

Main problem is F61S.BHZ01 - work ongoing, **Replace by MCB for 2007.**

A total of 11 'weak magnets' will be reduced to 8 for 2007.

Detailed list of problems and plans available in slides.

Difficult access to magnets in primary zone, very radioactive.

Quest for reorganization of East Area beam lines with new and fewer types of magnets and easier accessibility. To reduce manpower and radiation budget.

Problems cannot be managed with available staff!

Action: Global review of East Area

- North Area has better situation in terms of different types.

Secondary beams: 540 installed, 22 types. TT20: 62 / 10. TDC2: 73 / 12.

Main actions proposed concern **QTA/QTL and MSN manifold replacement and the production of spares for the TT20 splitters (risk of vacuum leaks).**

The magnet interlock system is obsolete.

Experimental Area Magnets

Comments - Questions

- East Area renovation would be more cost effective on the long term activity, but PS2 has to be taken into account in the overall picture.
Can we keep the East Area alive for some 10 years in the present way?
Renovation mandatory to keep the East alive for 10 years
- *Manpower situation very critical. Loss of expertise*

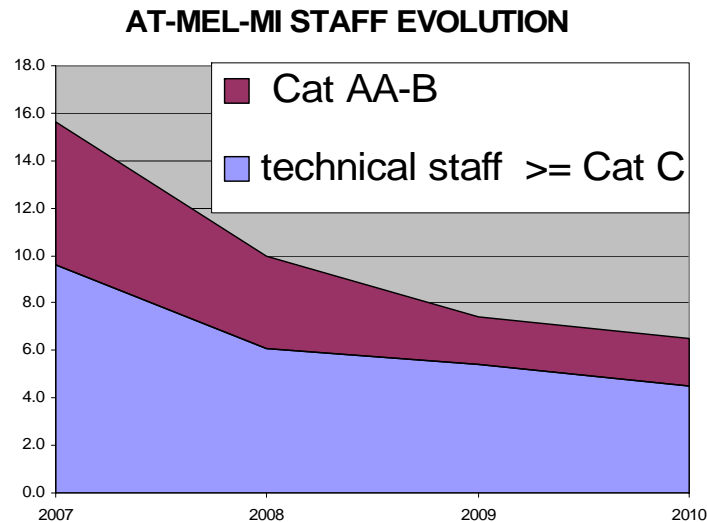

FAULTS STATISTICS

	2004	2006
Exploitation period	26 weeks	20 weeks
Interventions	166	162
Duration of interventions	130 H	155 H
Mean intervention time	47'	57'
Interventions / converters	0.4	0.52
Power faults	21	12
Electronics faults	94	91
Operation faults	6	29
External faults	18	30

Y.Gaillard: Power converters

SPS NORTH AREA POWER CONVERTERS: MAIN CONCERNS

Electronic card reliability

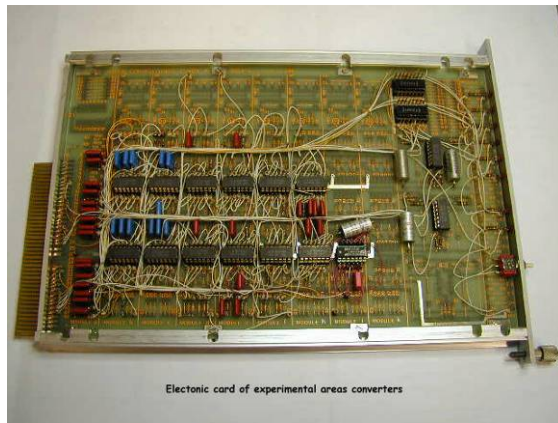

~ 6600 electronic modules of this type are in operation

Wire wrap
Obsolete components

Cabling ageing

Split insulation

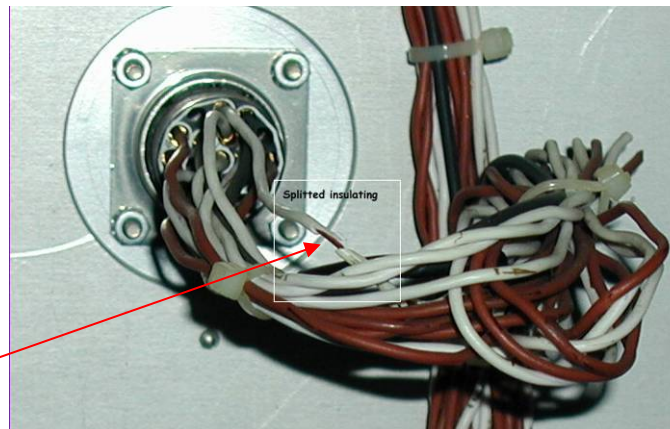

PCB connector contact

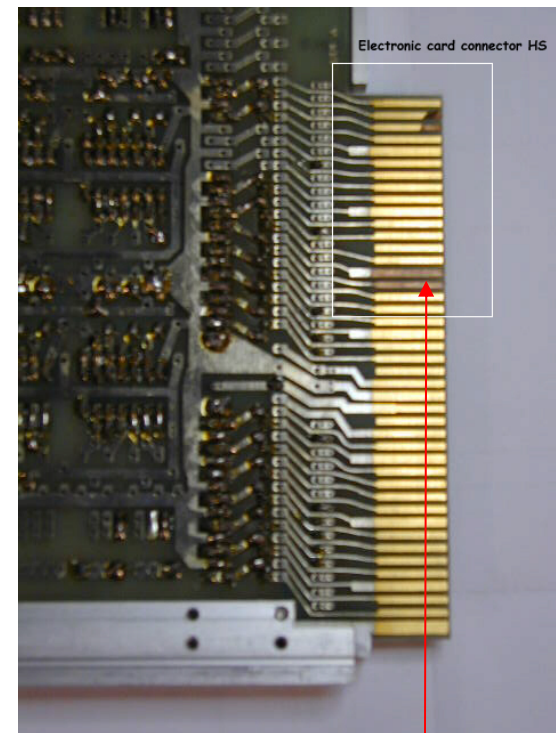

Damaged gilded contacts

FUTURE CONSOLIDATION PROJECT

- Replace 180 power converters ($\leq 500\text{A}$) by new switch-mode power converters.
- Renovate 150 thyristor converters.
- New electronic control.
- Budget estimation : 23 MCHF
- Provisional schedule: 6 years
 - 2 years studies and contracts
 - 4 shutdowns for implementation
- Manpower: 19 FTE
- No budget allocated in AB consolidation! (below red line!)
Nothing before 2010!

- ❑ North Area: 330 converters of 8 types, in operation since 1976.
Obsolete electronics (wire-wrapped). Unreliable electronics cards and cabling.
Control system renovated. Some teething problems observed during operation.
Databus timing problem now solved. Drivers added to relieve databus load.
No controls problems anticipated for 2007.
But MTBF very low (<7000 hrs) and decreasing.
Propose to keep present maintenance level and expertise (First line).
But a **major consolidation program is required**: 23 MCHF, 19 FTE, 6 years.
- ❑ East Area: 80 converters of 10 types.
In operation since 1970, but electronics replaced in 1991.
Main problems with polarity switches - improved for 2007.
Need to improve diagnostics - which service to call.
Improve diagnostic tools

Power converters

Comments - Questions

- *Could replace only the electronics of NA converters, but there are also many problems with the power part.*
- *Interlocks now formally transferred to AB/CO.*
A discussion with them must be initiated

R.Nunes: Access systems

- SPS Zone North
- PS East Hall
- PS AD

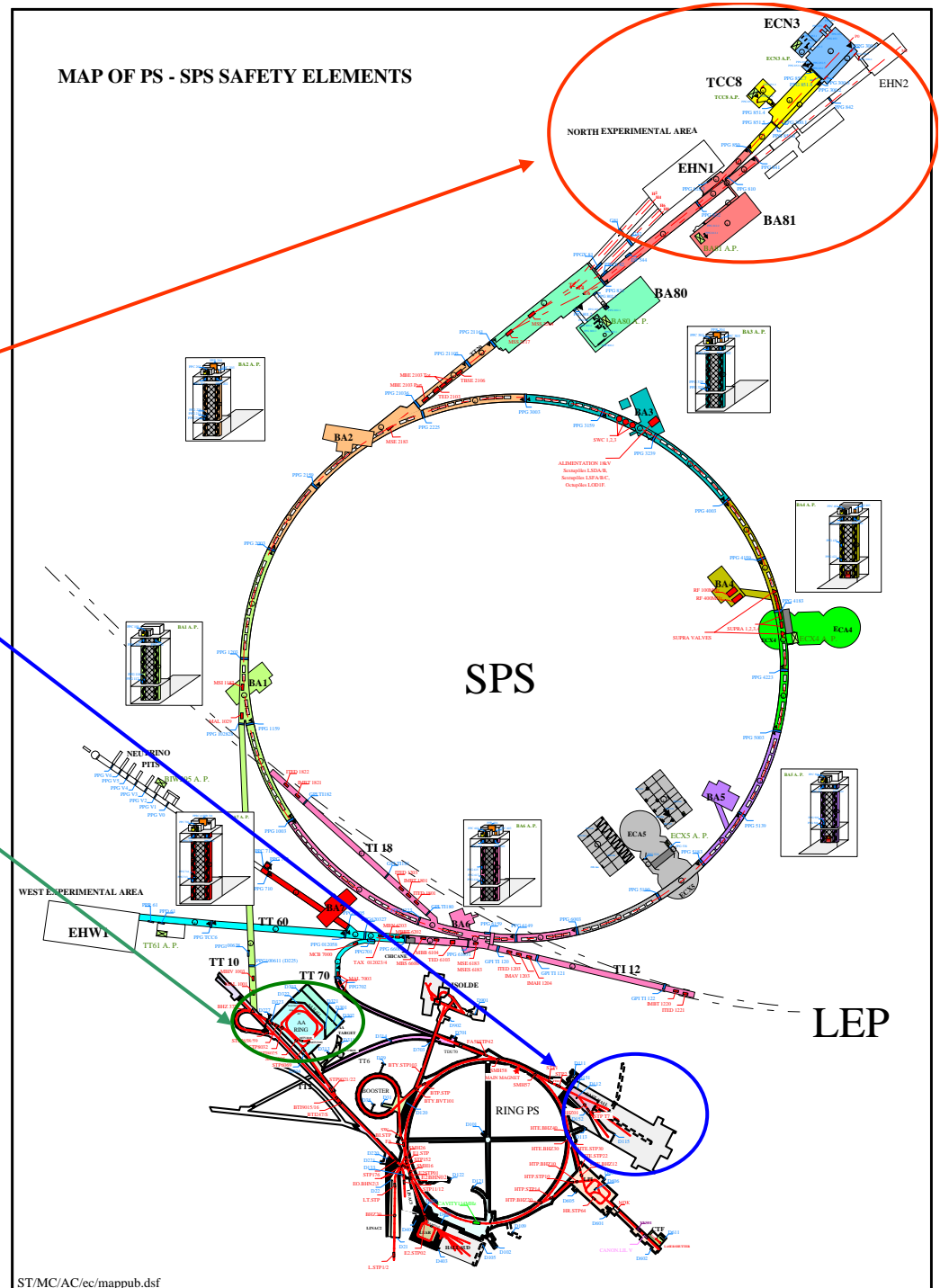

- ❑ One major problem in the North Area lasted over the weekend, due to non-availability of piquet service with outside contractor.

This problem will be solved by migration of Factory Link to Windows.

- ❑ The East Hall and AD access systems will be replaced (shut down 2007) by a new one, similar to the SPS facility but with modern PLC control. No access card required to access the area (this can be implemented at a later stage).

Reconfiguration of chains/zones via pin matrix.

Manual and PCR vetoes are implemented.

Possibility to extend to SPS North Area: To be investigated

Access

Comments - Questions

- It was confirmed that only the responsible have access to the racks that allow reconfiguration. Racks are in a protected building. Actions require validation with a special key.
- Like in the North Area there is a link between the areas system and the machine system (forced door, areas safe, etcetera).

E.Gschwendtner: CNGS

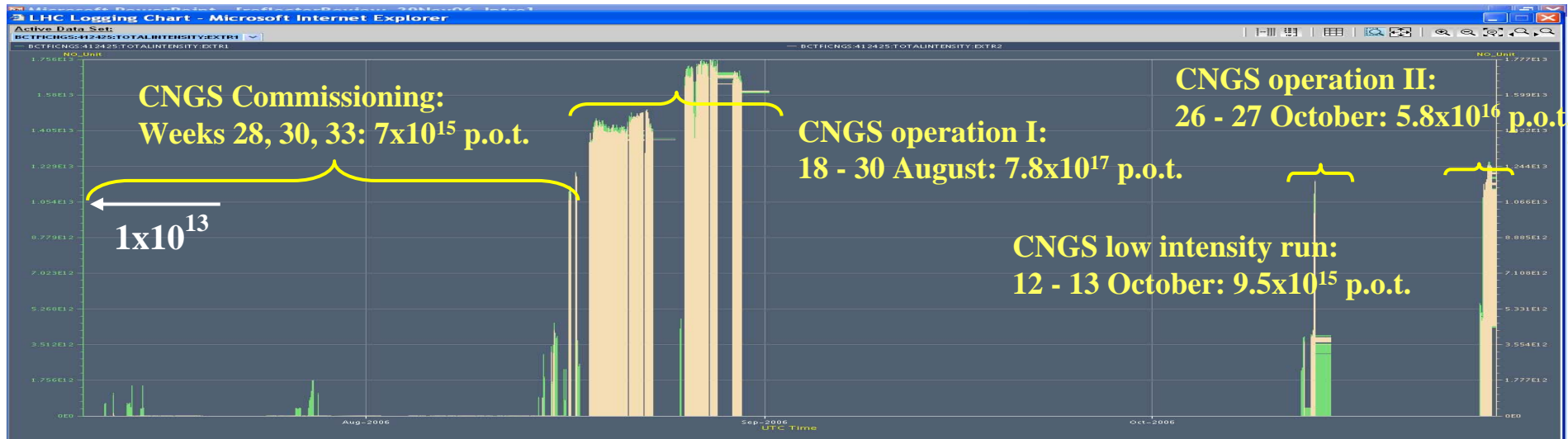

Opera

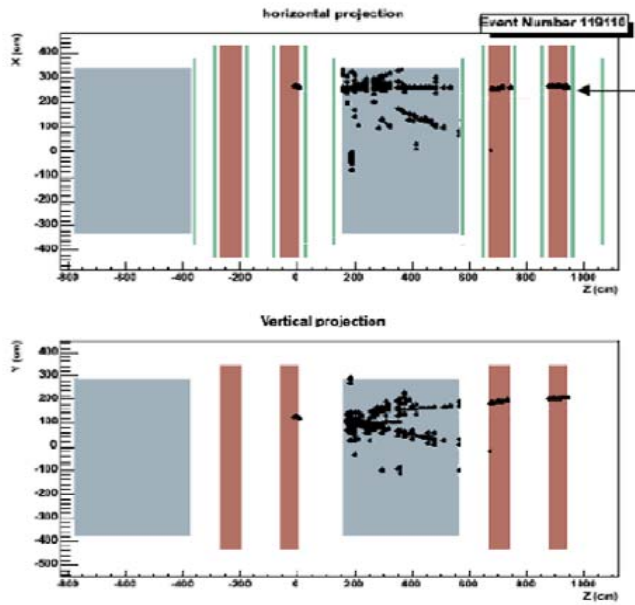

CC event in the first magnet

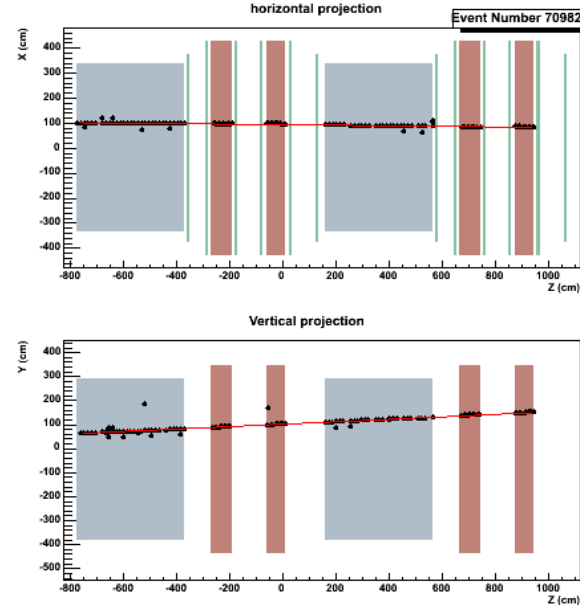

Muon from CC interaction in the material in front of the detector (BOREXINO, rocks)

The CNGS Reflector

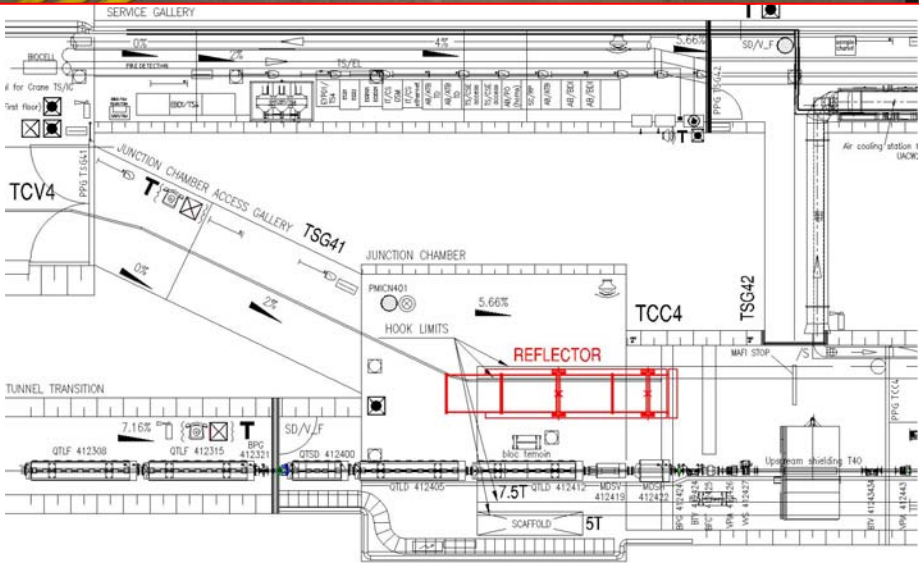
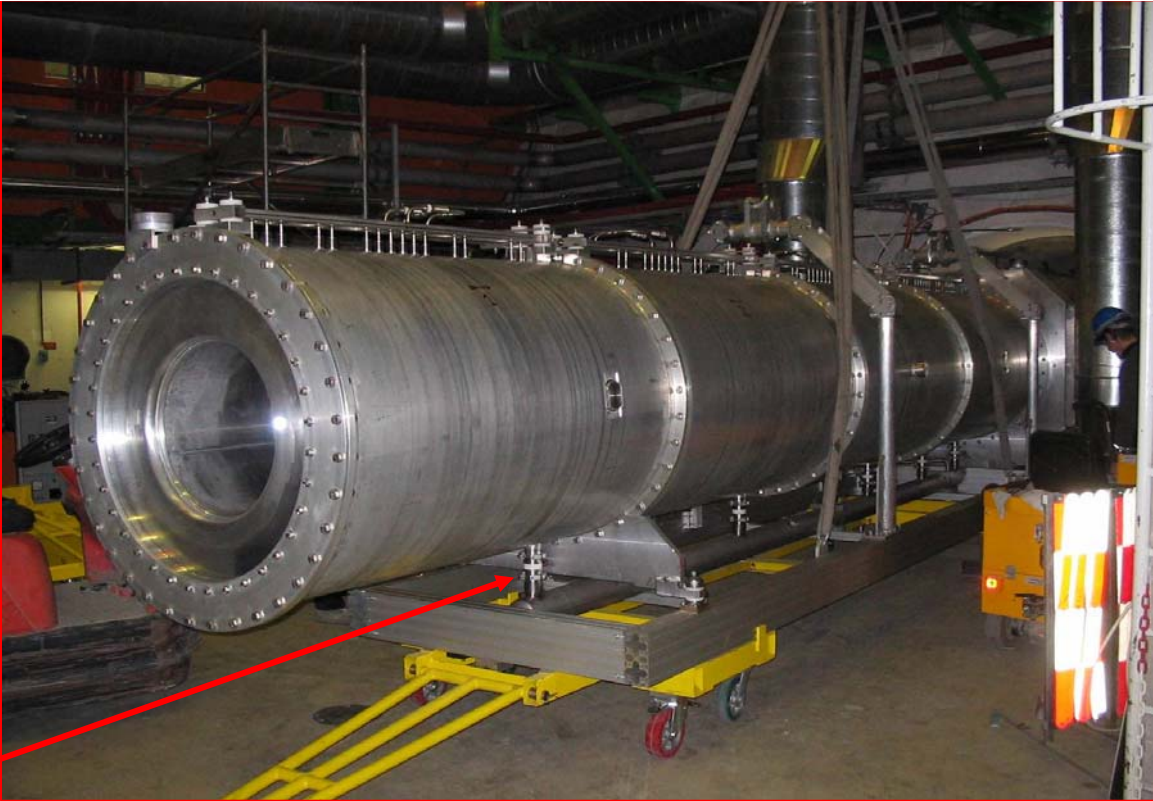
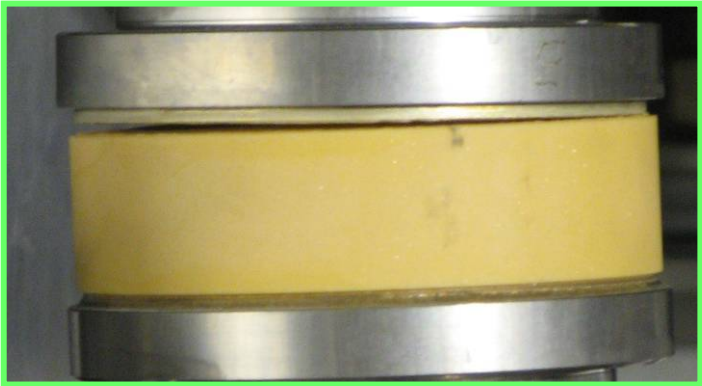

Repair location :
Remote control handling
procedure needed

CNGS Horns: Other Possible Weak Points

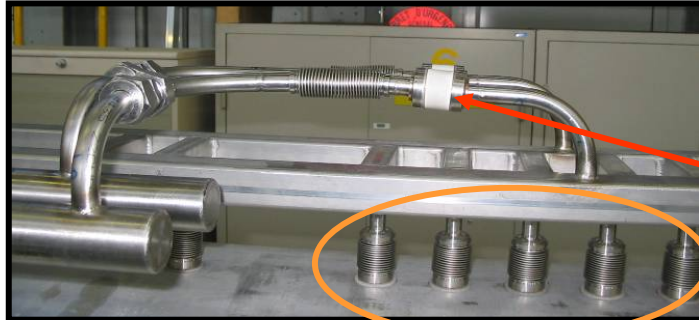

- **Water inlet bellows**
 - Thin stainless steel foil brazed on ceramic sleeve
 - Thin foil brazed to water tube

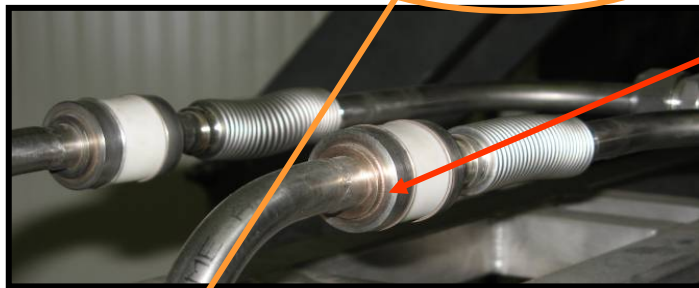

- **Water sprayers**
 - Double-walled → no leak when bellows failure
 - **50% already replaced**

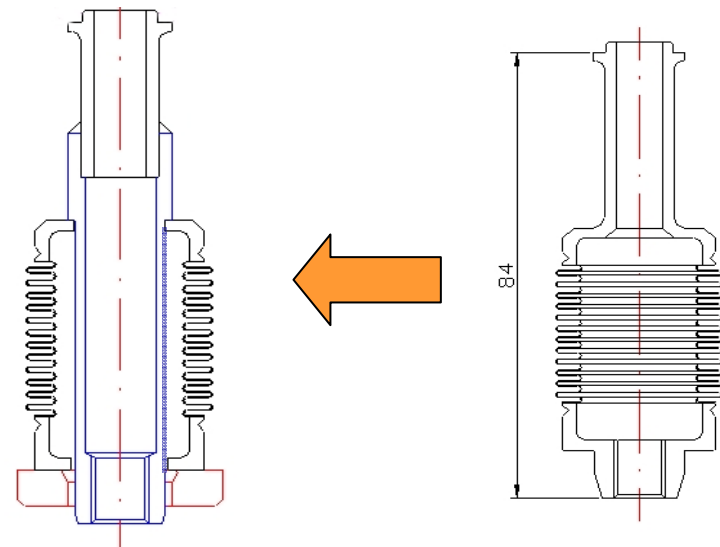

- ❑ CNGS commissioning went very smoothly. Dry runs were very helpful.

Need long cool-downs before allowed to access.

More studies required for TBID calibration, polarity change, muon detector linearity, alignment stability between target and horn

- ❑ Reflector developed water leak.

Repair strategy has been defined. Cannot be done in situ.

Minimal repair could be ready just in time, but no contingency.

- ❑ Other possible weak points: water inlet bellows and water sprayers.

Both are being studied and can be improved.

- ❑ Opera mass production of bricks has not yet really started.

In most optimistic scenario 125 kbricks by the end of the run, 206k needed.

CNGS

Comments - Questions

- The present repair planning has to keep some contingency, to be included in the overall schedule. (OPERA RB requirement: 75%)
- Water inlet bellows will be modified on the spare horn.
Action on original horn and reflector to be discussed with RP (welding required!)
- If the water leak had not happened after only 1% of a normal run, the intervention would have been excluded.
In the project, the horn is a disposable item (1 spare horn, No spare reflector). No repair has been foreseen.
- This leak is a strong indication for the **need of a spare reflector (Cost 300 - 500 kCHF)!**
Foresee a remote controlled installation procedure and a storage space.

Conclusions

- ***CERN is the place to be!***
 - unique, high quality facilities, excellent expertise and efficient support
 - took long time to build up
 - takes continuous efforts to keep
 - important & fundamental (non-LHC) physics program @ PS/SPS
 - more projects in “committee pipeline”
 - unique possibility of general purpose test beams at high energies
 - 2007: will be used by >47 different groups, O(1500) users
 - expect increasing demand from LHC-upgrade, ILC, ...
 - need feedback/dialog from/with community, e.g. need of a new Gamma Irradiation Facility...

- ❑ DIRAC running for 2 more years, then consider move to North Area
CLOUD commissioning runs. Plan physics runs 2010-2012.
Approved depending on resource availability/
East Area test beams 55% of available time
Coincidence of LHC and space experiments schedules.
Expected to increase from 2008 for LHC upgrade, ILC and others.
Consider to improve instrumentation, equipment, space.
Need for radiation facilities!
- ❑ COMPASS approved for 2007. Proposal review for 2008+ very soon.
P326 proposal under review. Run 2009+.
NA49 future proposal for different ion species.
Test beams in very strong demand. Worldwide unique facility
- ❑ CNGS: commissioning run followed by physics as soon as committee approval.
- ❑ CERN is the place to be. Installations and expertise are unique.
Must be preserved!

- **No plans exist for ions other than lead. Have to study impact on AB. Ongoing.**
- **Consider reorganization and optimization of East Area**
Fewer beams but of better quality and easier access to equipment?
- **PS2 experimental area potential should be communicated to user community.**
Underground for the high-intensity beams.
- **Manpower needs and availability in support groups for restarting beams must be communicated to the Committees**
- **Users should clean out better after their experiment stops.**
- **Lead ions for fixed target require good time structure - to be studied.**
Heavy ion interlock dismantled. **New system to be designed (LOKN).**
Take into account that operation is now from CCC.
Route via LEIR to PS is the only option in the future.
- **CNGS: "No bricks, no beam"**