

BNL FPC development

Wencan Xu

June. 6, 2018

Outline

- High power coupler for present projects at BNL
 - FPC for CEC
 - FPC for LeREC
- High power coupler for future project at BNL
 - 500 kW FPC for 563 MHz fundamental SRF cavity for eRHIC e- storage ring
 - 100 kW FPC for 3rd harmonic cavity (1689 MHz) cavity
- Summary

FPC for CEC 704 MHz 5-cell SRF cavity.

- CW 20 kW
- Ceramic window
- Water cooling window
- Conduction cooling with water
- External Q: $8.5E6-2E7$ adjusted by 3-stub tuner
- Had a few arcs during Run2016

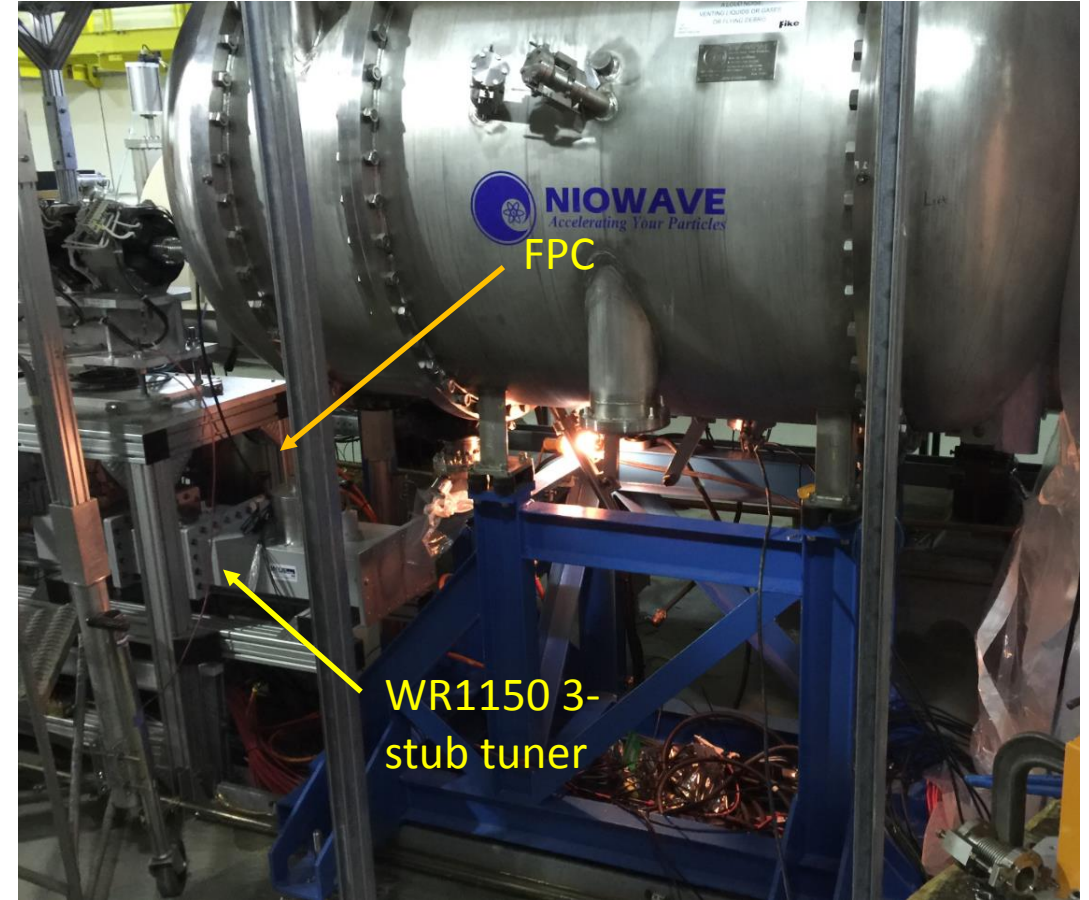

Arc of FPC during Run16.

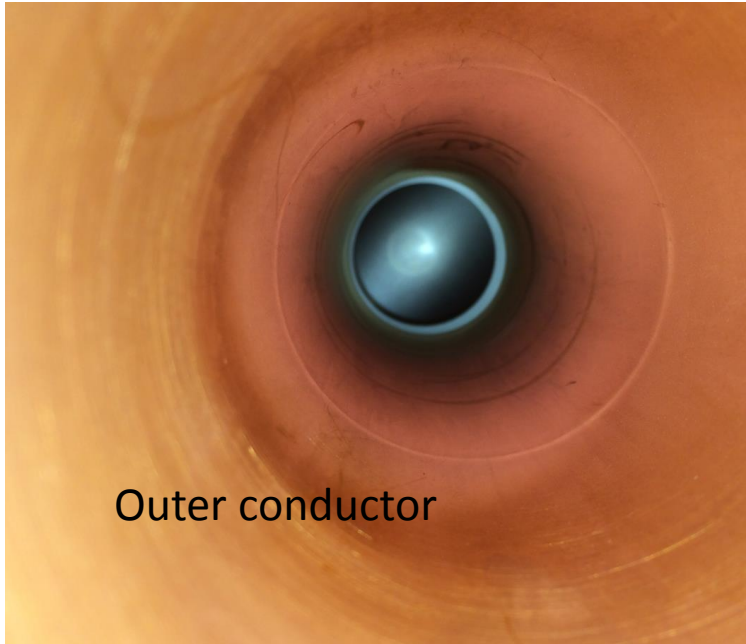

Outer conductor



Inner conductor
before processing



Outer conductor after
ultrasonic cleaning



Inner conductor after
ultrasonic cleaning

After polishing and micro90 ultrasonic cleaning



New FPC for CEC 5-cell cavity

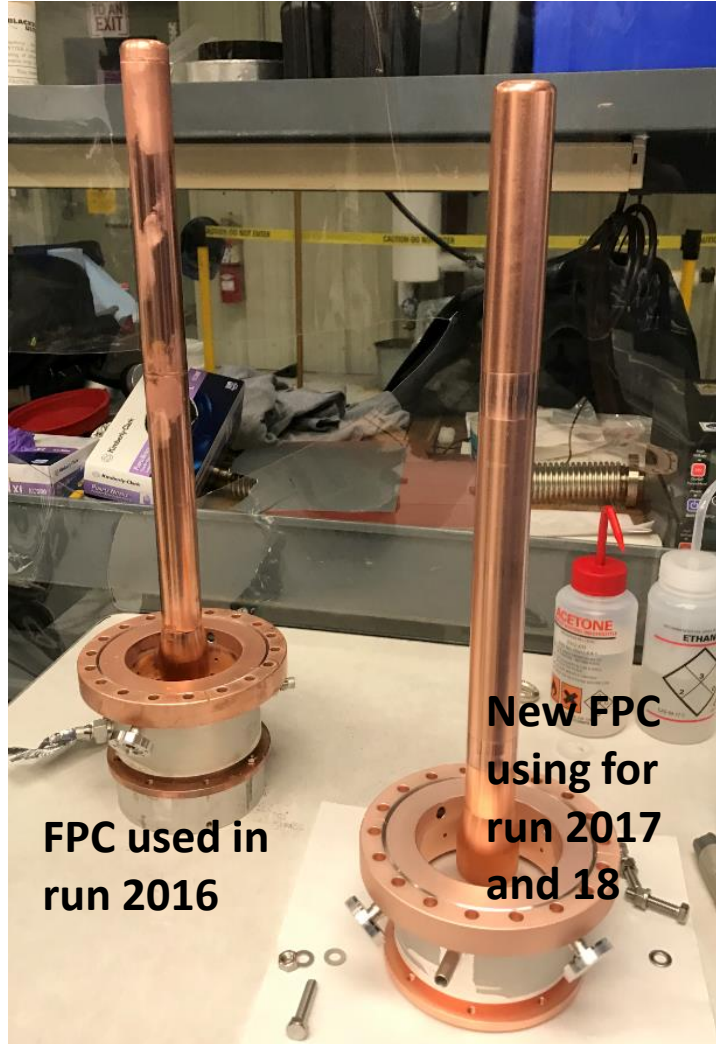

- The new FPC was cleaned with ultrasonic only, and installed into the cryomodule.
- It runs well, with occasional arcing (several times in two runs).

FPCs for SRF gun

- Two 500 kW CW coupler
- Fixed Qext
- BeO window, water cooling
- Helium cooling outer conductor inside cryomodule
- Run for ERL SRF for couple years.
- The cryomodule was modified as a booster cavity/cryomodule for Low Energy RHIC electron Cooling (LEReC).

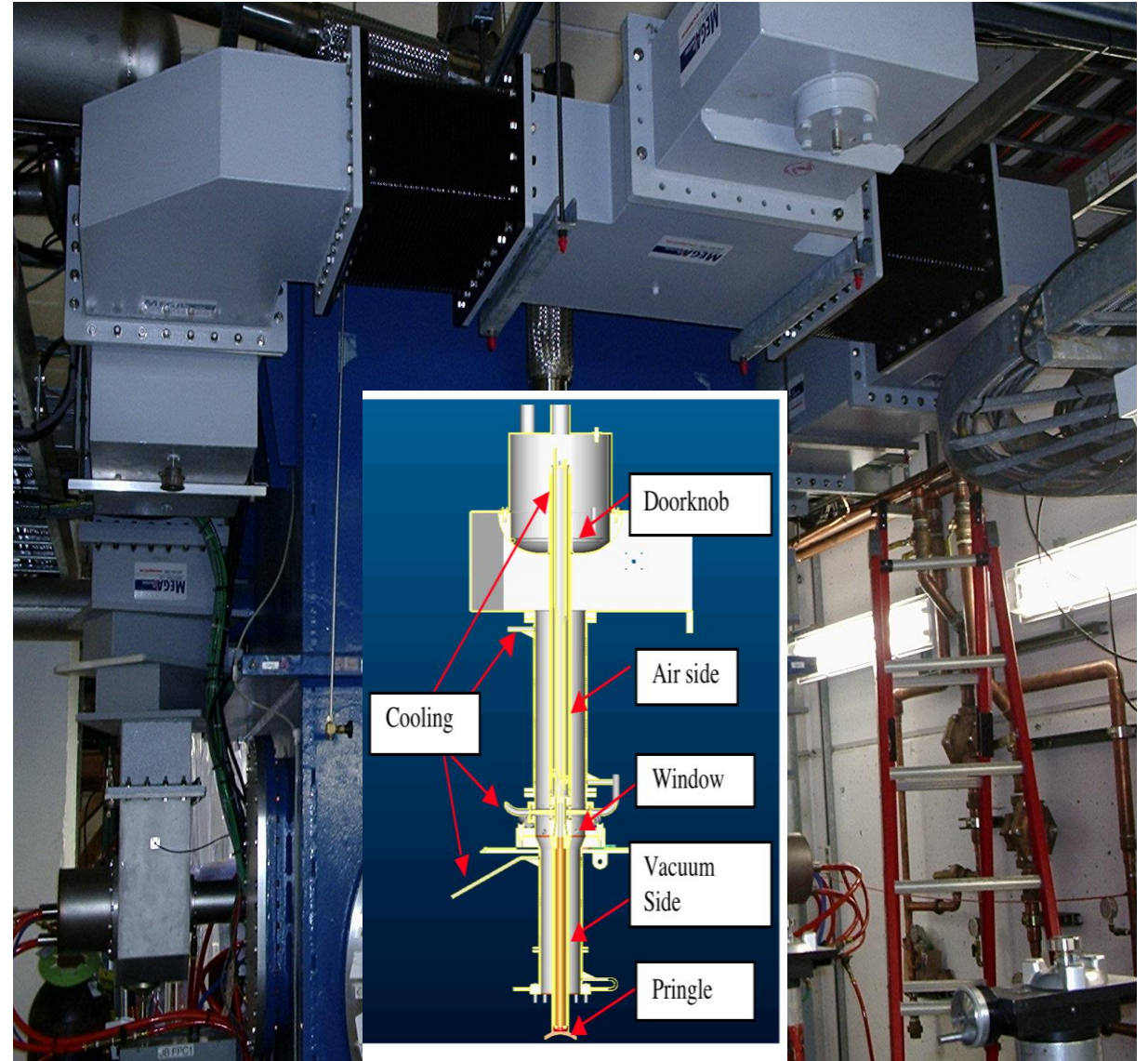

FPCs changes a SRF gun to a booster cavity

- Among many modifications, the external Q of two FPCs has to be adjusted from $5.5E4$ to $1.7E5$. This is done by adding a spacer to retract the tip of FPC 5 mm each.
- As the FPC was retracted and the pringle shape is closer to the outer conductor, we analyzed the field.
- The FPCs were re-conditioned in the conditioning box.
- As for LEReC's electron beam coming from the DC gun is only 400 kV, the kick from the FPCs were analyzed.



External Q adjusting for LEReC

Ib(mA)	Vc(MV)	Pb(kW)	Qext(1E5)	Max.Voltage[MV] (df=200Hz)*	Cavity limit due to Bpeak
35	1.6-2	56-70	4.7-5.9	1.13-0.8	2.9
45	2.2	99	5.0	1.06	2.9
85	1.4	120	1.7	3.6	2.9

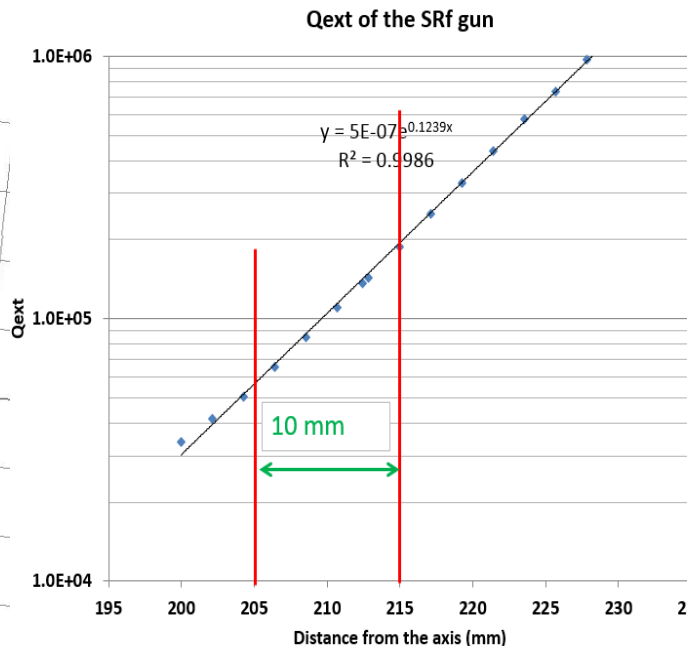
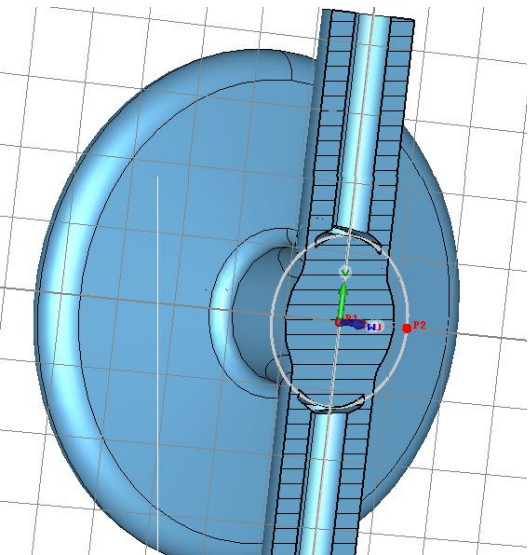

LEReC 704 Booster Calibrations	Qext	Cal Pwr (dBm)	Cal Mag at ADC	Dir Coupler (dB)	Extra Atten (dB)
704 Bstr Pickup	3.45e+11	18.97	21634	0	0
704 Bstr PA Total Fwd Power	165000	16.67	9828	60	0
704 Bstr PA Total Refl Power		16.62	5202	60	0
704 Bstr HOM Pickup	1	13.86	10655	0	0
704 Bstr FPC1 Forward Power		13.85	19750	70	0
704 Bstr FPC1 Reflected Power		13.85	19661	70	0
704 Bstr FPC2 Forward Power		13.85	19519	70	0
704 Bstr FPC2 Reflected Power		13.85	19858	70	0

- The choice of the Qext (1.7E5) is to make sure that we are able to do RF condition in-situ, where we only have 120 kW, instead of 1 MW power source for ERL.
- With CST simulation, we need to retract the FPC 10 mm away each other, or 5 mm each. And this is done by a spacer gasket.
- As the pringle gets closer to the outer conductor, the peak field increases 30%, but that is not an issue.
- The external Q is measured and verified by beam energy of 1.65E5 (within 3%).

Impact of dual coupler to the beam

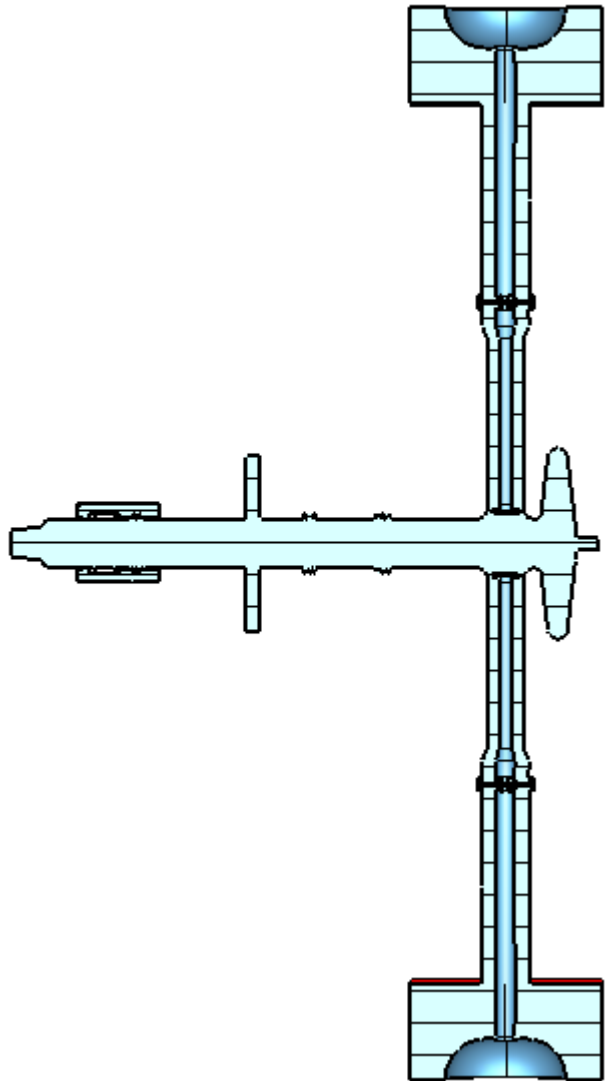

$$V_z(x, y, z) = V_0 \sin(kz + \varphi) + \frac{V_2}{a^2} (x^2 - y^2) \sin(kz + \varphi)$$

$$\Delta\theta = \frac{\Delta P_x}{P_z} = \frac{2V_2}{ka^2V_0} x = x/L$$

Beta	Quadrupole focusing length L (m)	R/Q- quadrupole Ω/m^2	R/Q-dipole [Ω]
1	3.65	18.81	0.0237
0.8278 (Ek=400KeV)	3.32	21.35	0.0034
0.941 (Ek=1MeV)	3.50	20.13	0.0158

- Dual FPC get quadrupole focusing.
- Tiny dipole kick shown in the simulation may be caused by numerical reason. However, in reality, manufacture error may cause dipole kick.
- However, with non-symmetry RF drive, dipole kick is easily existed.

FPC inspections.



This FPC is "good" as well.

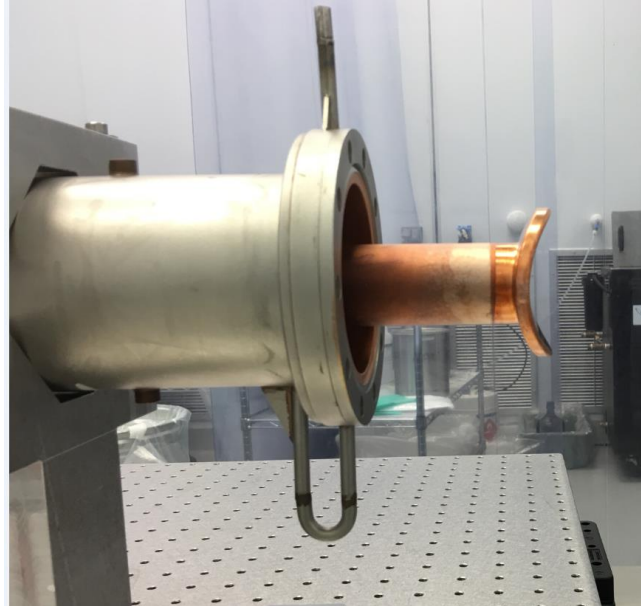
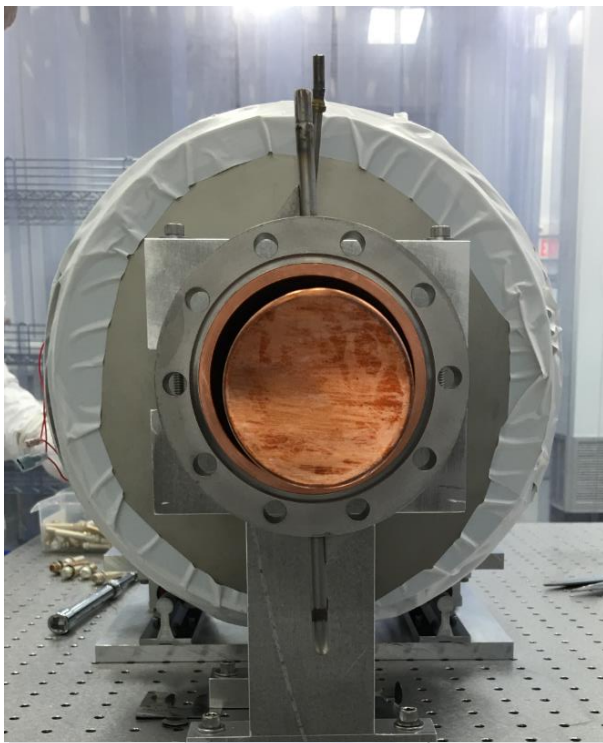

This FPC is good.

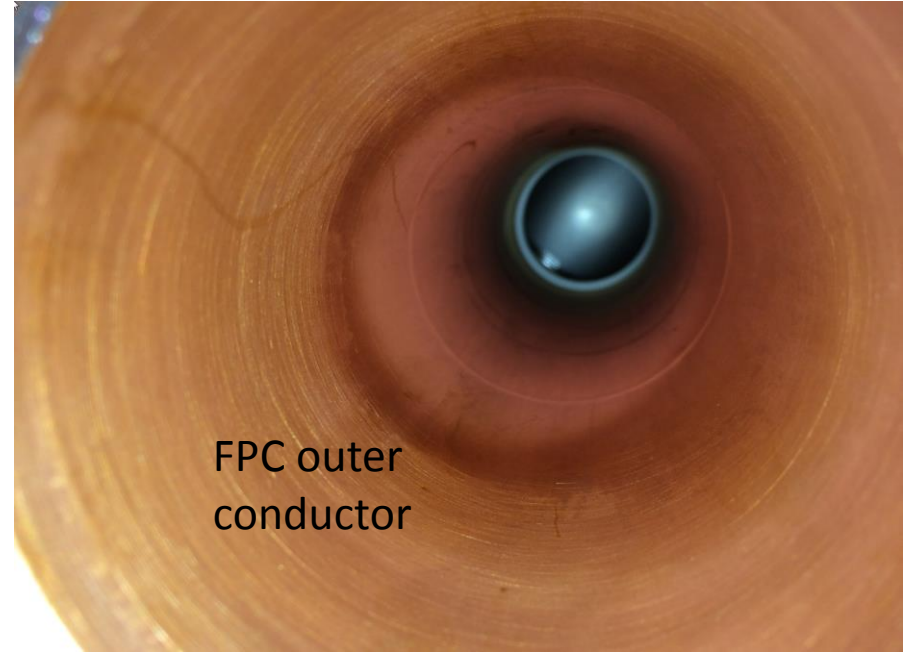

FPC outer conductor

Re-processing and re-conditioning the FPC.

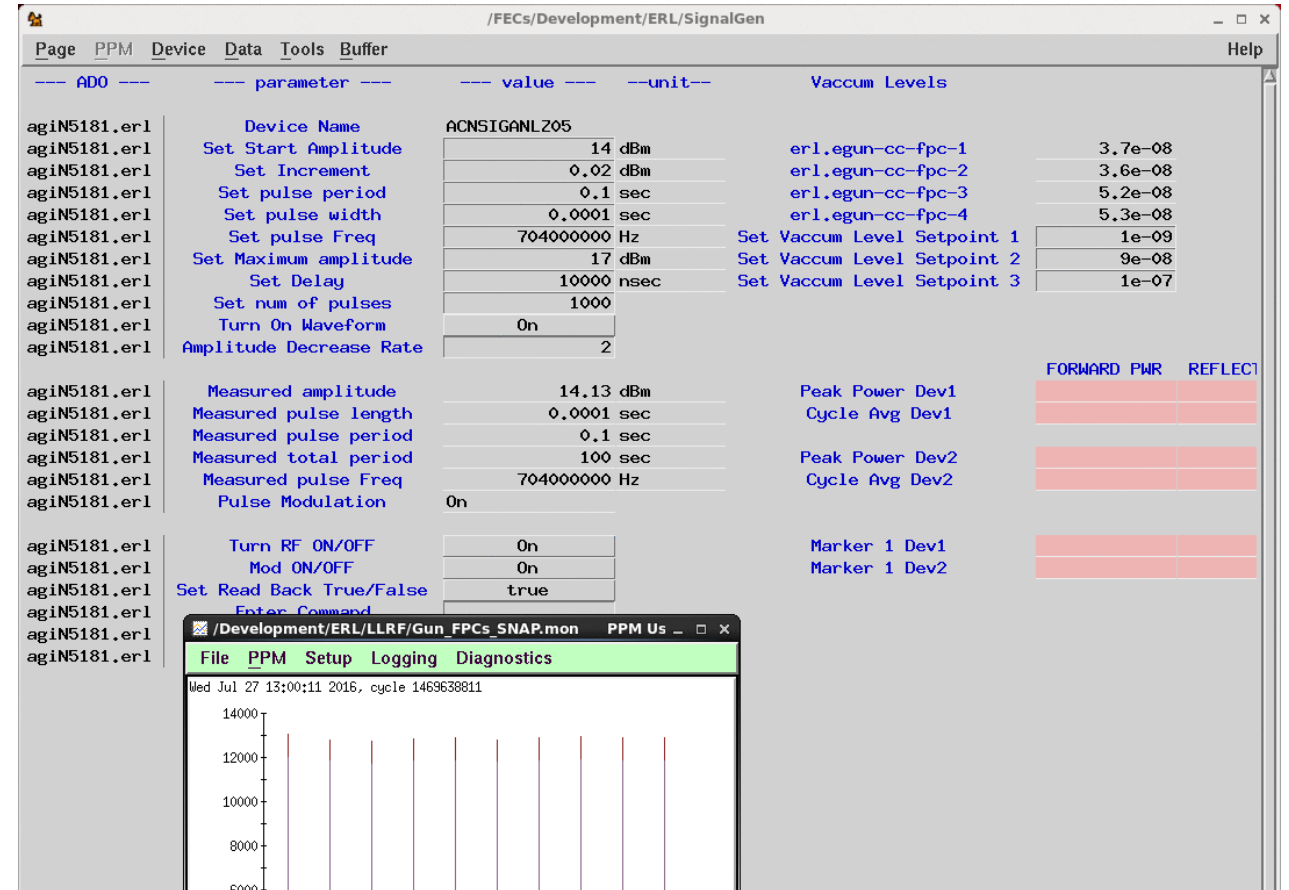
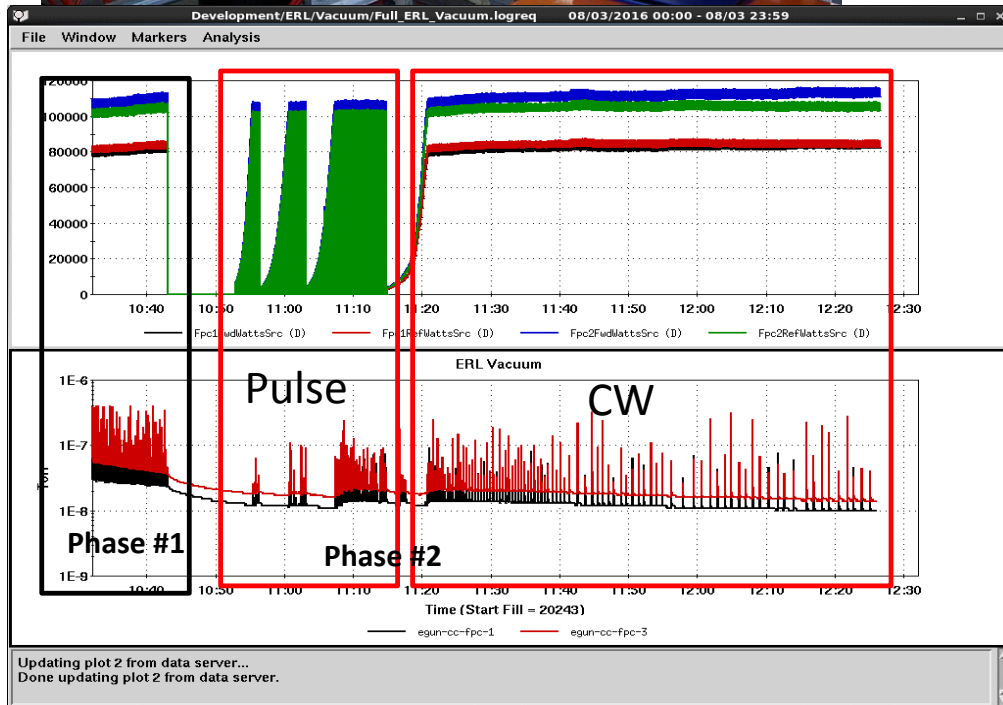
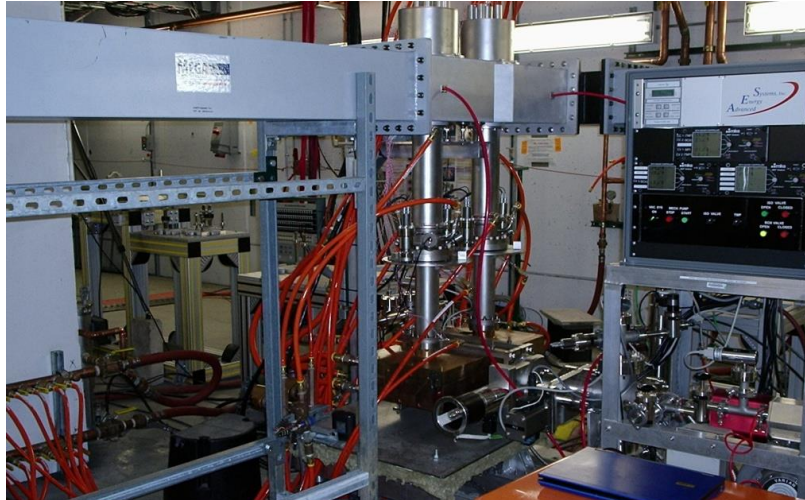

- The FPCs weren't carried out any wet processing, just blew down and stored in the clean room!
- It is easy to condition up to CW 120 kW (double power of each FPC) in standing wave, less than 40 hours.

LEReC FPCs status

- The FPCs have been operated in cryomodule, since July 2017 .
- The cavity even was vented for HOM damper insertion in Oct. 2017.
- The cavity routinely operates for LEReC.

FPC for Electron-Ion Collider (eRHIC) at BNL

- eRHIC is a high luminosity ($\sim 10^{34} \text{cm}^{-2}\text{s}^{-1}$) Electron-Ion Collider proposed at BNL.
- A flexible RF system (tuning cavity's Q_{ext}) for e- ring is required to satisfy the wide range of operational scenarios.
- There are two SRF systems in the e- ring:
 - A 563 MHz fundamental SRF system to compensate the energy loss due to (up to 10 MW) synchrotron radiation.
 - ➔ Adjustable 500 kW FPCs.
 - A 3rd harmonic (1689 MHz) SRF system to stabilize the electron beam by stretching the bunch length.
 - ➔ 100 kW FPCs.

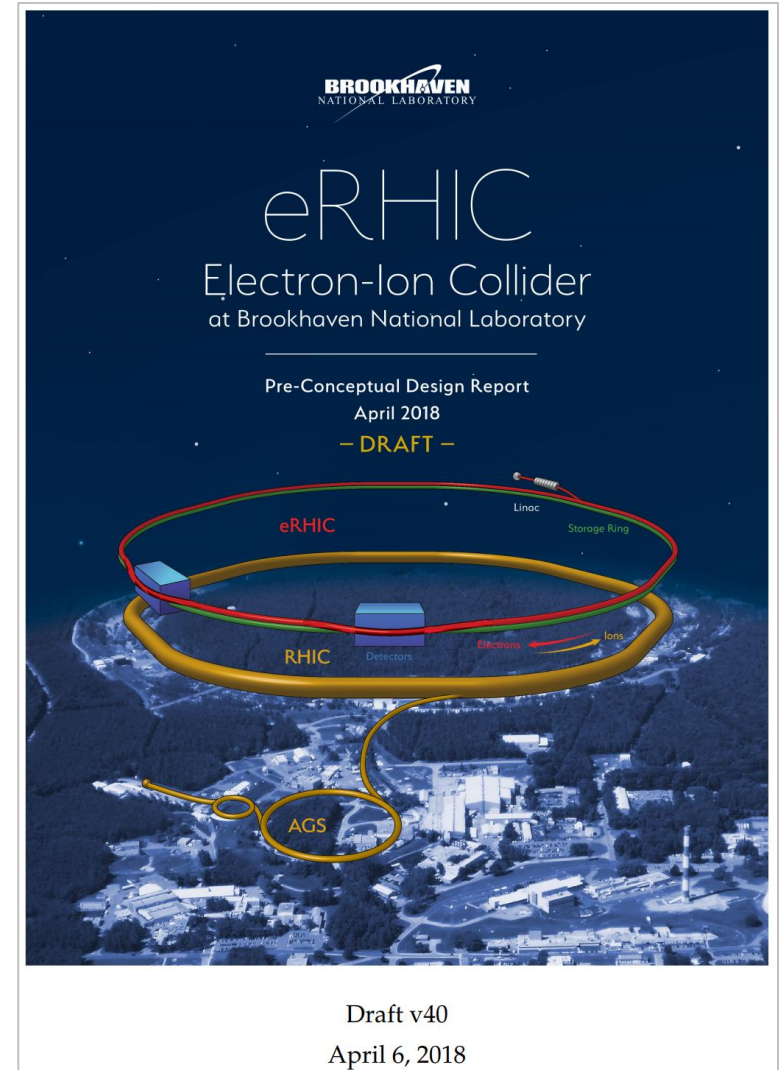

e⁻ Storage Ring RF Requirements

Parameter	Unit	5 GeV (Beam-beam limit)		10 GeV (Maximum lumi)		18 GeV (SR Power Limited)
		Med Lumi	High Lumi	Med Lumi	High Lumi	
Peak Luminosity	10 ³⁴ cm ² s ⁻¹	0.056	0.307	0.44	1.05	0.145
# Bunches		660	1320	660	1320	330
Bunch Charge	nC	48	24	48	24	10
Bunch length	rms mm	23	23	19	19	17
Average Current	A	2.48	2.48	2.48	2.48	0.26
Synchronous Voltage	MV/turn	1.29		3.67		38.5
Sync Rad Power	MW	3.2		9.2		10.0

Note:

- eRHIC requires a flexible SRF system for wide range of operational scenarios.
- 563 MHz fundamental RF system is for energy loss compensation.
- Bunch lengthening 1689 MHz (3rd harmonic) RF system is required for beam stability.

Fundamental 563 MHz RF System

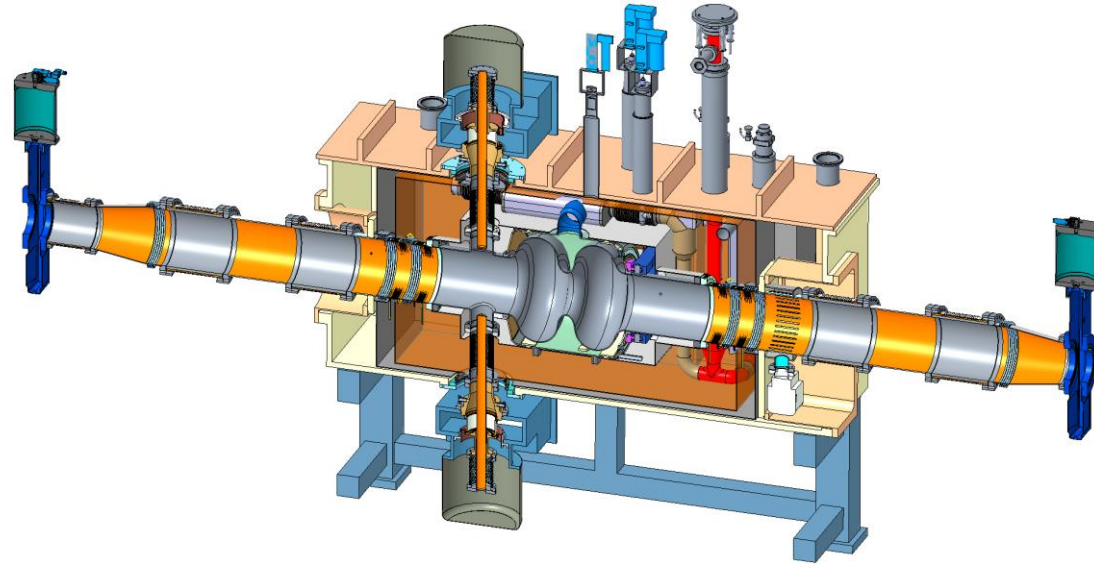

- 563 MHz is 7200 harmonic of the RHIC revolution frequency (78.2 kHz), or 5th harmonic of 112 MHz for 1320 bunches.
- Single 2-cell 563 MHz SRF cavity per cryomodule
- Operating at 2 K.
- **2x 500 kW adjustable fundamental power couplers.**
- **The external Q value has to be adjusted from 4E4 – 2.75E5 (for various operation scenarios).**
- 4x SiC Beamline HOM Absorbers (BLAs).
- 12 cryomodules in total.
- Multibeam IOT is the likely option for the power source.

Parameter	Value
Frequency	563 MHz
R/Q	146 Ω
E_p/E_{acc}	2.75
B_p/E_{acc}	5.21 mT/MV/m
Operating gradient	4.1 to 11.3 MV/m

Third Harmonic (1689 MHz) SRF System

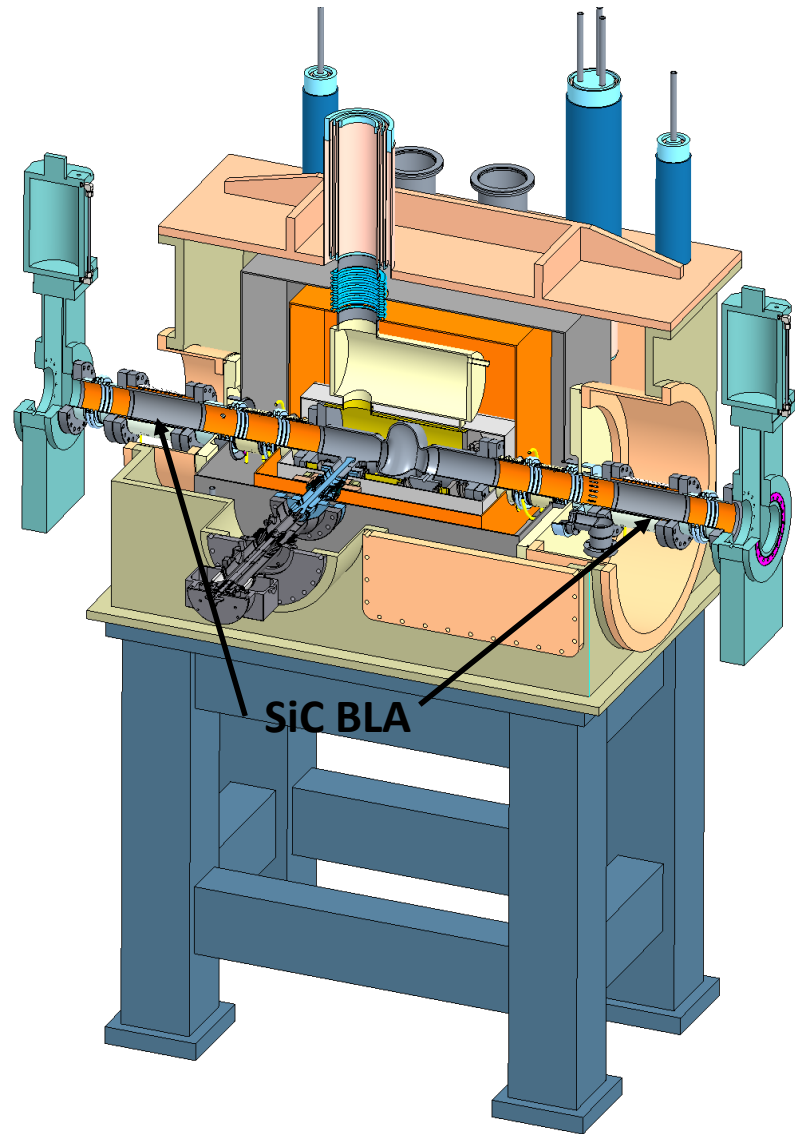

- 3rd harmonic cavities are required to stretch the electron bunches.
- One single-cell cavity per cryo-module
- Requires tunable FPC.
- Room temperature HOM absorber
- 2K operation condition
- 4 cavities are required for eRHIC.
- **Up to 206 kW, the fundamental power has to be extracted from the cavity.**
- **The Qext: 1.58E5-1.66E5**

Parameter	Value
Frequency	1689 MHz
R/Q	103 Ω
E_p/E_{acc}	2.04
B_p/E_{acc}	4.47 mT/MV/m
Max. operating Gradient	21.2 MV/m

Two Routes to adjust Qext.

- The first method is to adjust the Q_{ext} by changing the relative position of the inner conductor and cavity.
- The second method is to adjust the Q_{ext} , out side the cavity, by a impedance transformer. This is the way we are pursuing.

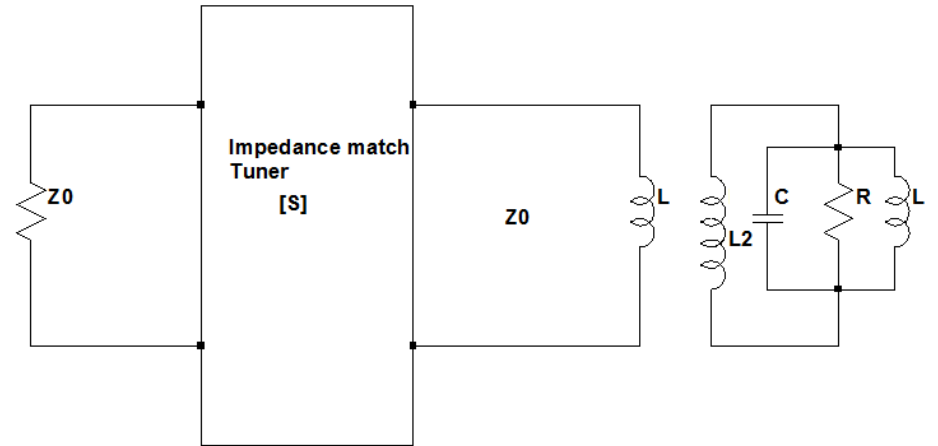
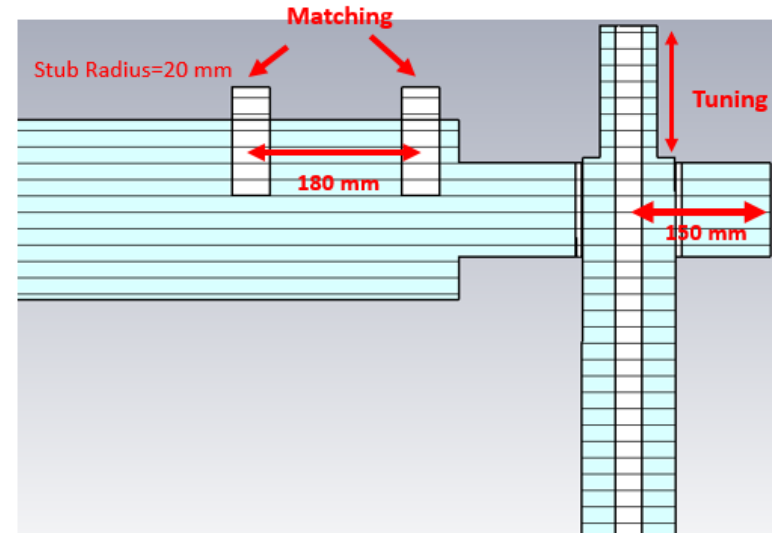

Matching condition

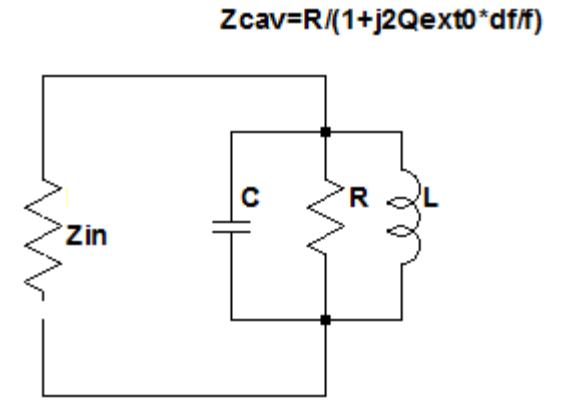
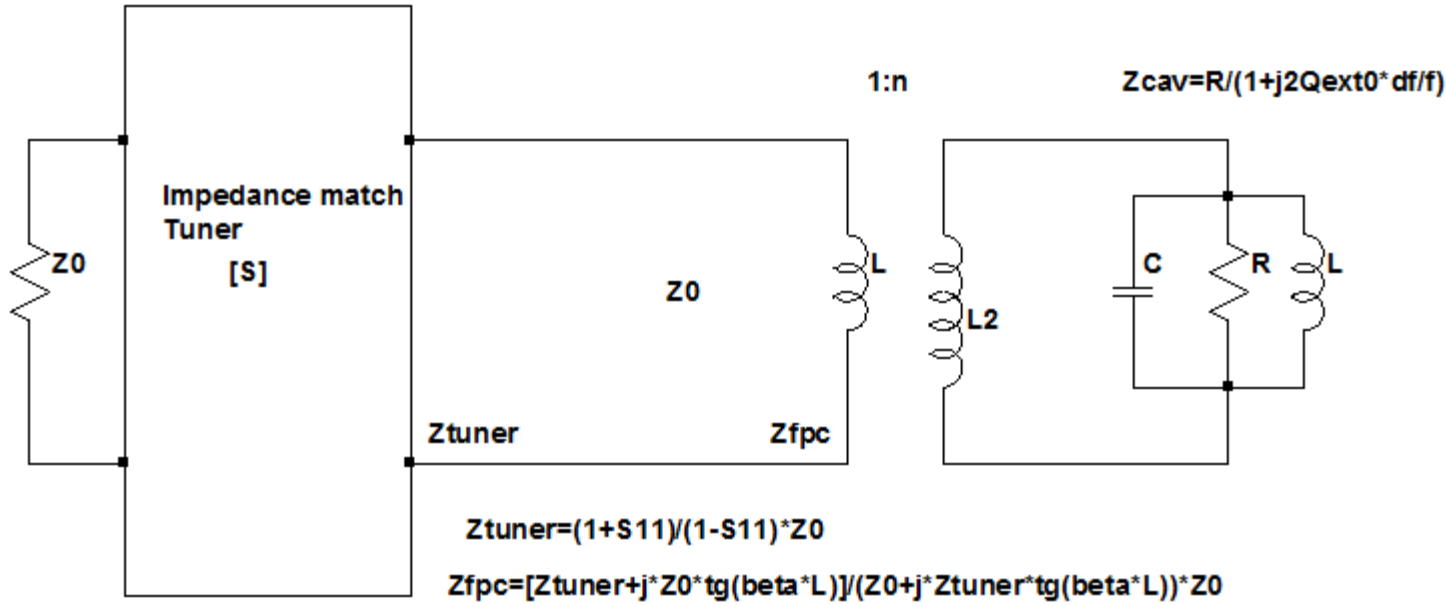

$$Z_{in} = Z_{fpc} \cdot n^2$$

$$Z_{total} = \frac{\frac{R}{Q} \cdot Q_{ext1}}{1 + j \cdot 2 \cdot Q_{ext1} \cdot \frac{\Delta f}{f}}$$



$$Q_{ext1} = Z_{fpc} / Z_0 \cdot Q_{ext0}$$

$$Z_{fpc} = Z_0 \frac{\frac{1 + S_{11}}{1 - S_{11}} - j \cdot \text{tg}(\beta l)}{1 + j \cdot \frac{1 + S_{11}}{1 - S_{11}} \cdot \text{tg}(\beta l)}$$

If $\beta l = n\pi$

Then, $Q_{ext2} = \frac{1 + S_{11}}{1 - S_{11}} Q_{ext0}$

Tuning Q_{ext} with impedance transformer

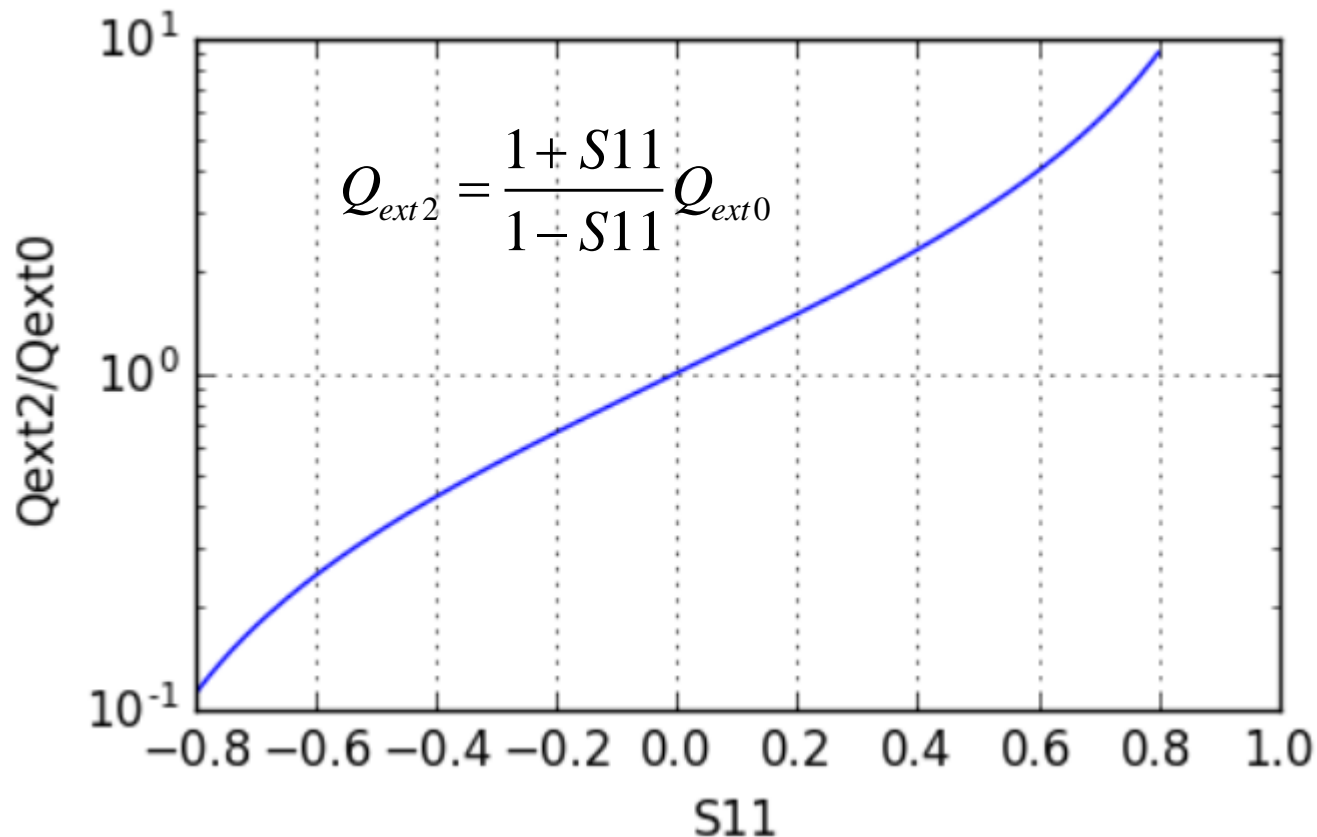

- Ideally, the external Q value can be varied within a large range.
- The issue here is that one has to tolerate the standing wave between the cavity and impedance transformer.
- Two impedance transformers:
 - Three-stub tuner (be careful with RF fingers): We have been using 3-stub tuner for up to 50 kW in 704 MHz. (Picture in next slide)
 - Waveguide junction

3-stub tuner, shalf and spring fingers



3-Stub tuner as impedance transformer

- 3 stubs, $\frac{1}{2}$ wavelength distance between stubs
- Center stub actually 0- insertion into WG
- increases Q_{ext} by changing insertion of stubs 1+3
- With OD =60mm stubs

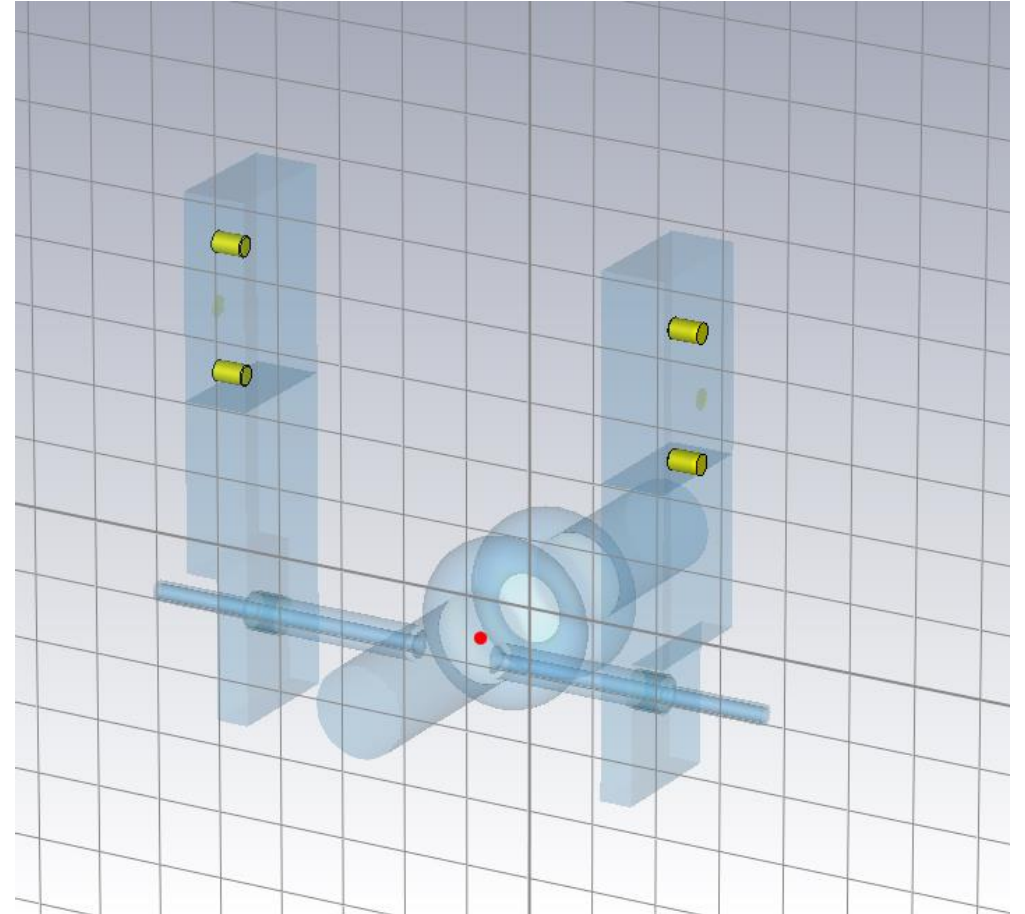
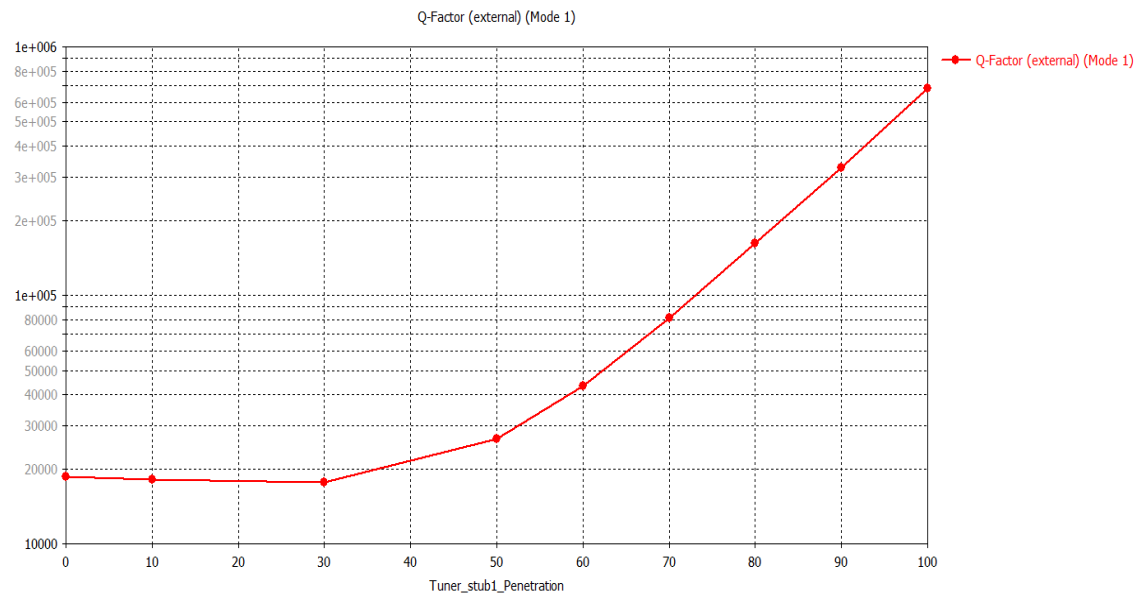

Power on stubs

- Normalized power on stubs to forward power per cavity (two couplers).
- Surprisingly low power: $1\text{MW} \times 4e-5 = 40\text{W}??$ (Have to check!)

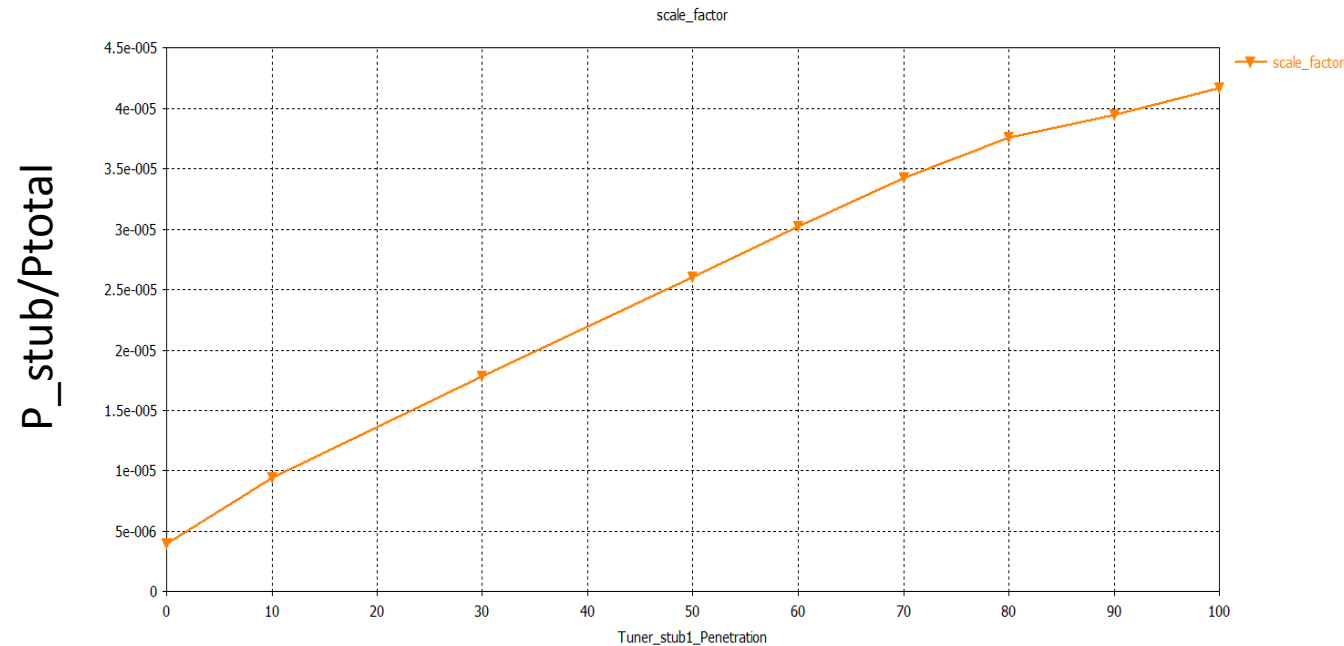
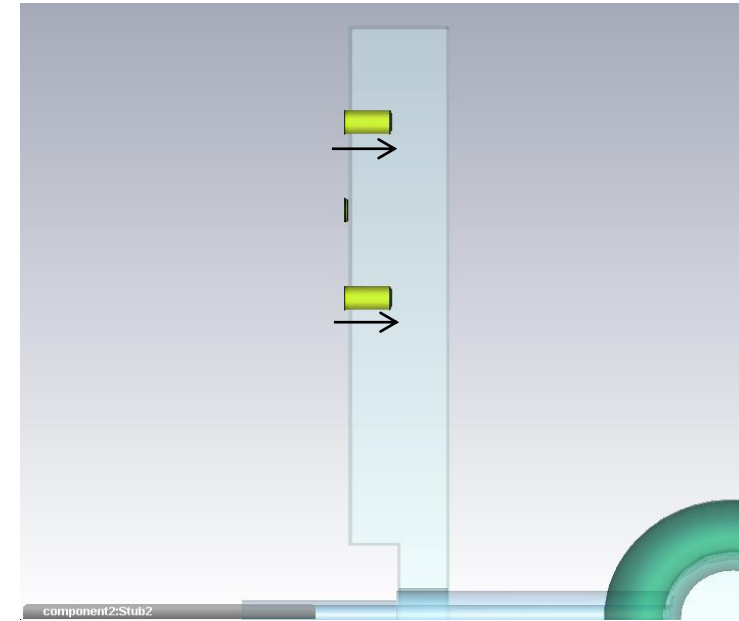

Waveguide junction as impedance transformer

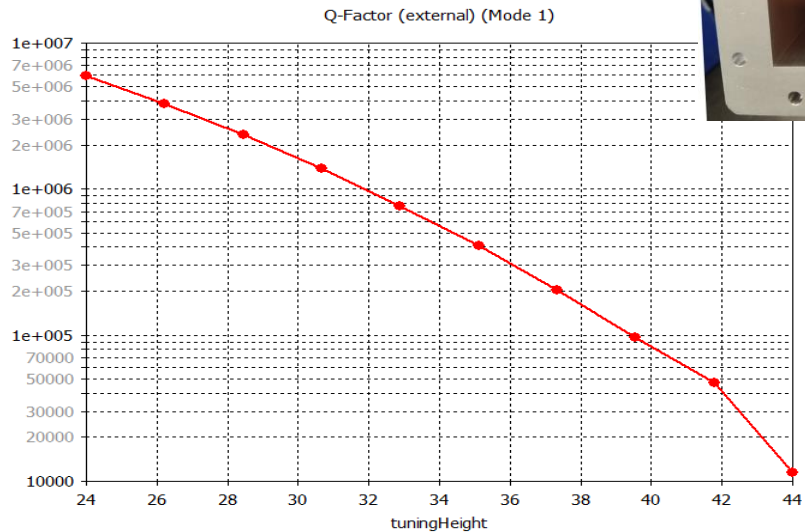
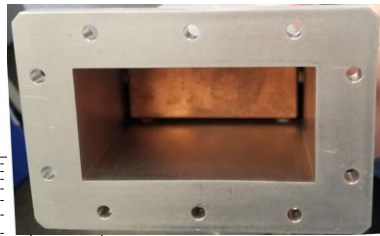
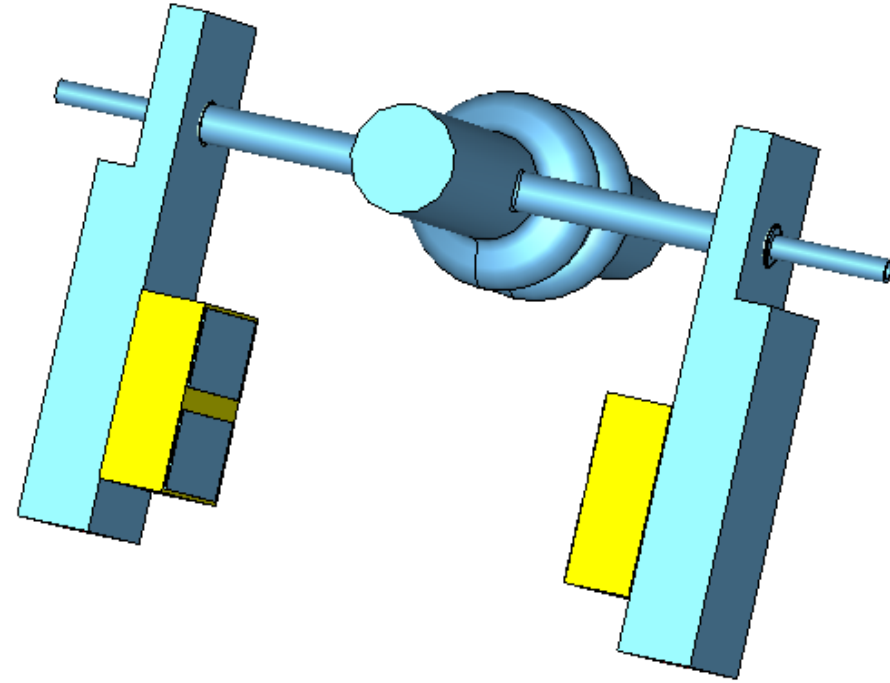
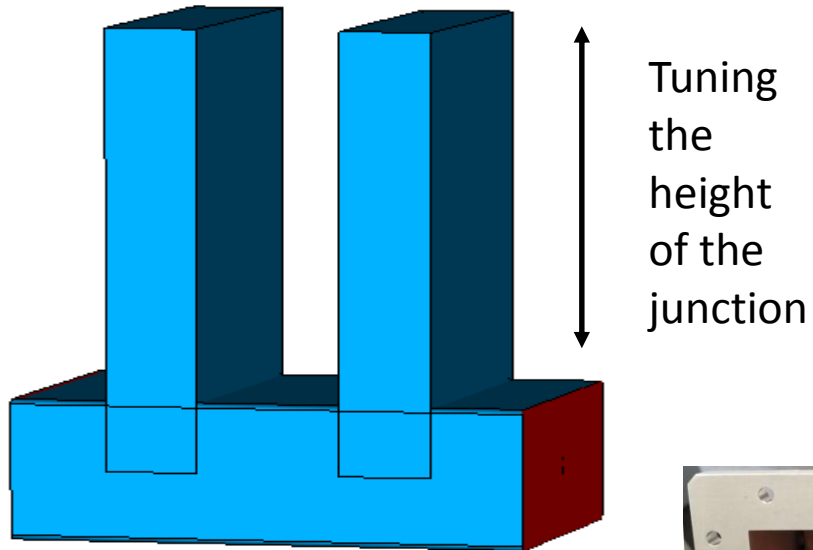

Note: The height of the waveguide is quarter wavelength when tuning height is 0. And the tuning height reduces the amount of tuningheight in the plot, i.e, making the height shorter. The range that we need is 43 to 37mm. This curve will change when the location of the tuner change, a better location should be optimized.

Power loss on the Cu plate

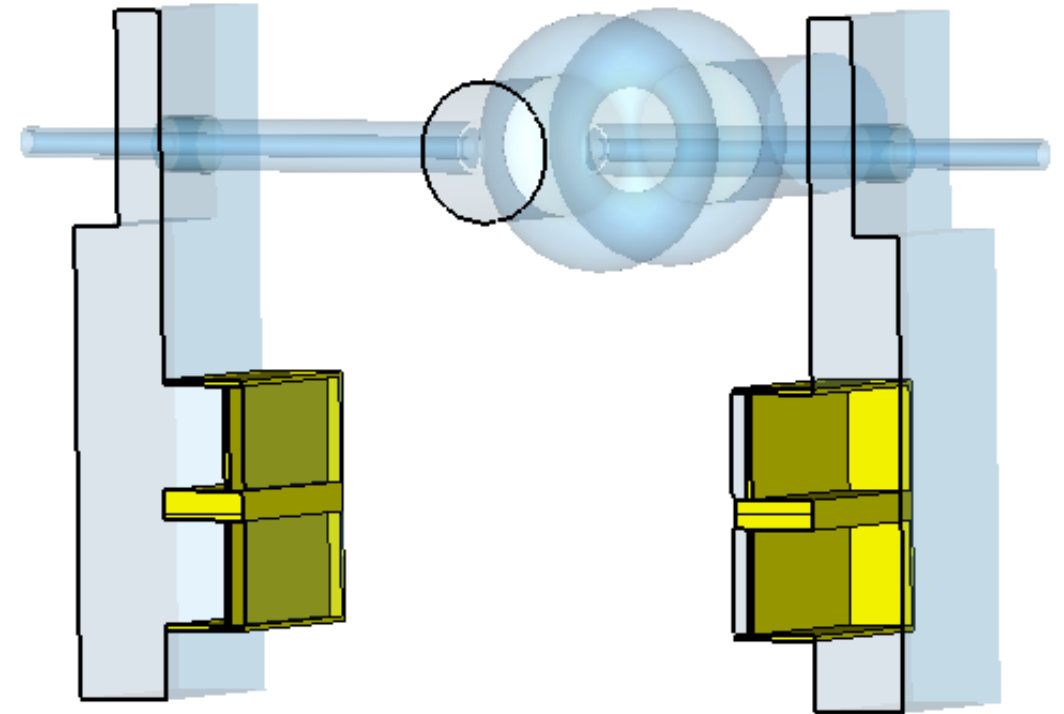
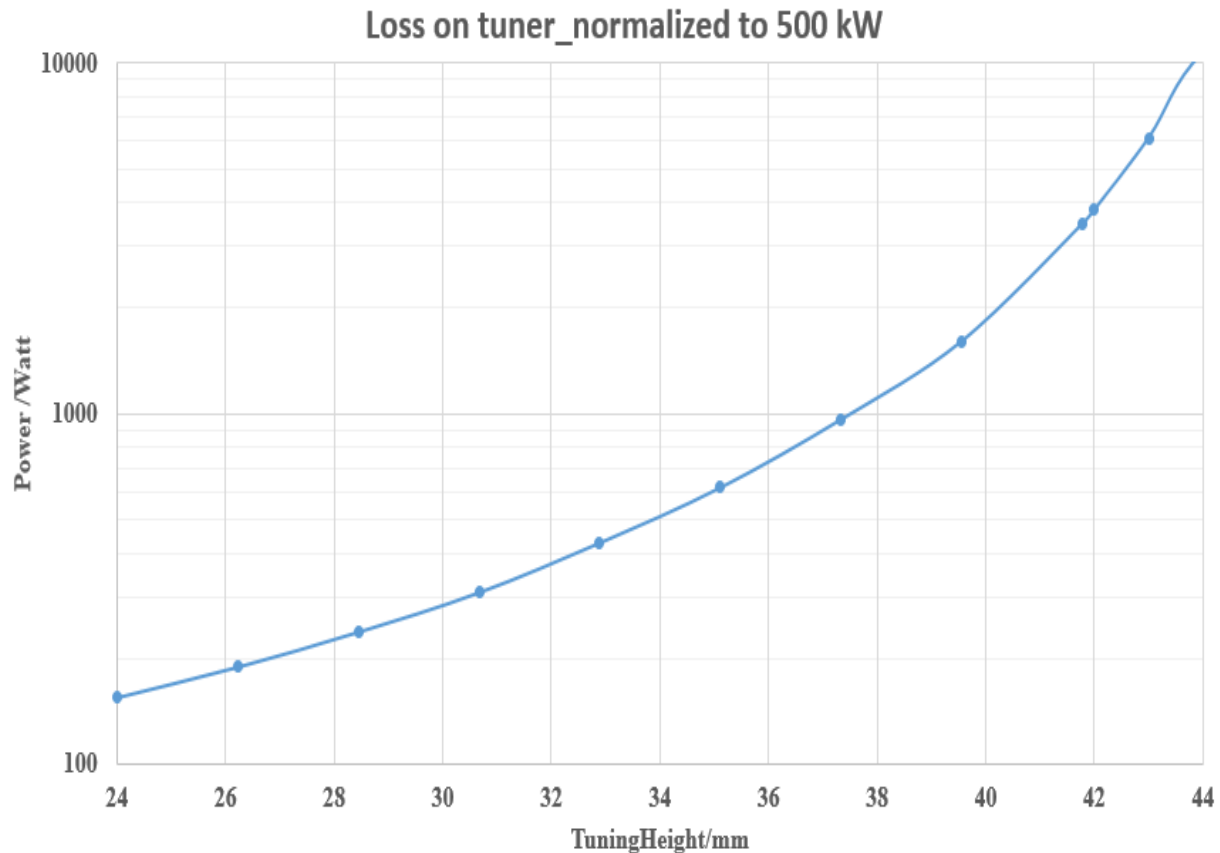

- The loss in the plot shows the loss on the copper enclosure of the two tuners.
- The maximum power loss is 6 kW for now, I believe that it can be reduced through changing the tuner's geometry parameters.
- 6 kW should be able to cool with water (3 GPM, 10 degree temperature rise).

Status and plan of the project

1. Two 500 kW fixed FPCs has been placed order.
2. The impedance transformer are ongoing optimization;
3. Will condition the FPCs up to 500 kW in standing wave next year, with and without impedance transformer.

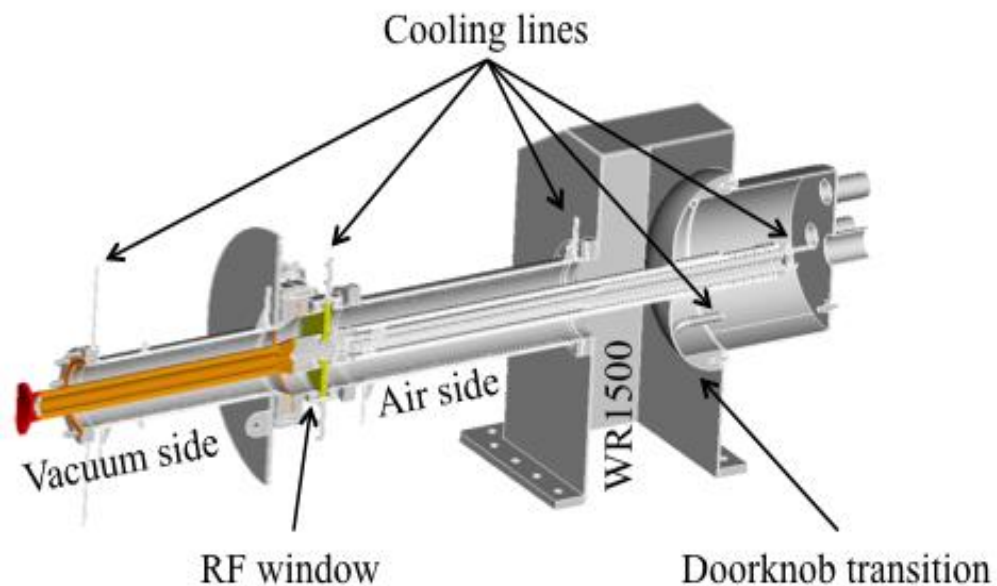

Waveguide junction in the conditioning box.

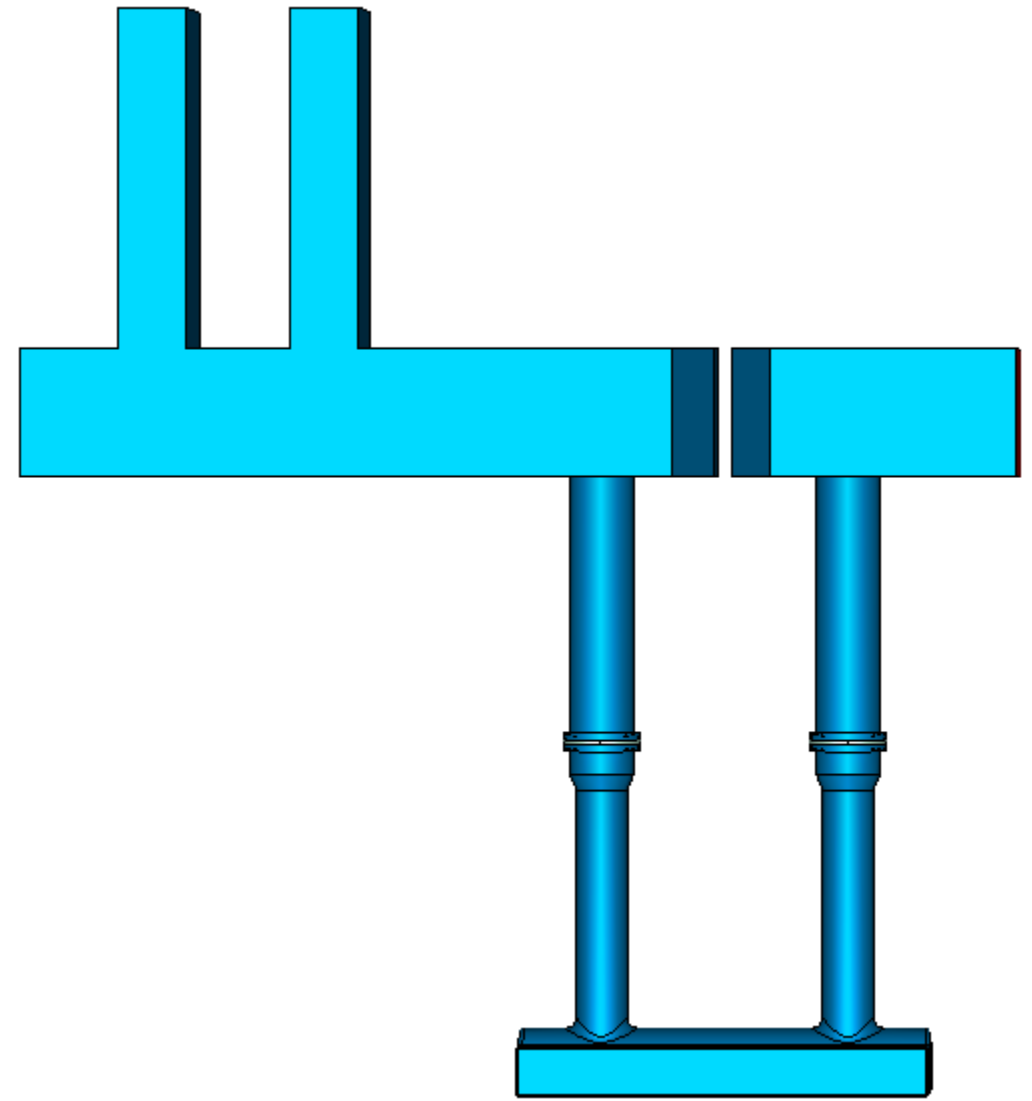
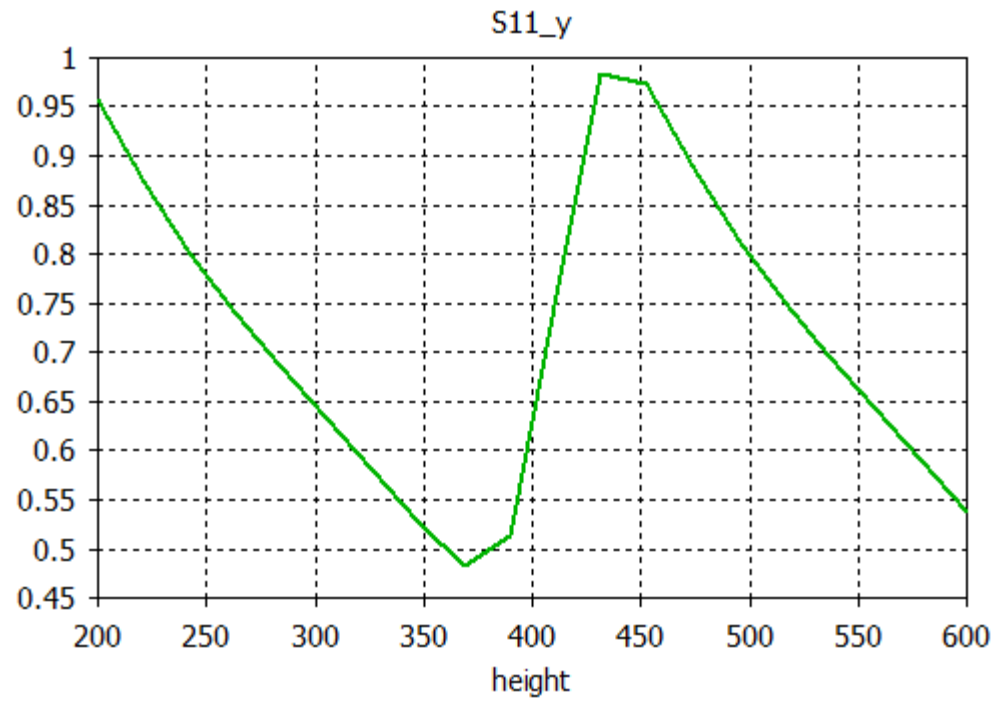

Summary

- FPC operates routinely in CEC 704 MHz 5-cell cavity
- FPCs operates routinely in LEReC 704 MHz booster cavity
- FPC developing for eRHIC is ongoing, and will test the tuning effect of impedance transformer next year.

Acknowledgement (incomplete)

Kevin Smith, Doug Holmes, Gary MacIntyre, Scott Seberg, Cliff Brutus,
Alex Zaltsman, Philipp Kolb....