

Optimization of PSD technique on charge integration ratio to improve neutron/gamma discrimination for EJ-276 plastic scintillation detector

#176

Vo Hong Hai^{1*}, Phan Thanh Xuan¹, Vu Ngoc Tu¹, Masaharu Nomachi²

¹University of Science, Vietnam National University-Ho Chi Minh, Vietnam; ²Osaka University, Japan

*Email: vhai@hcmus.edu.vn

Experiment set-up and Materials

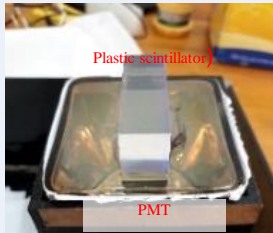
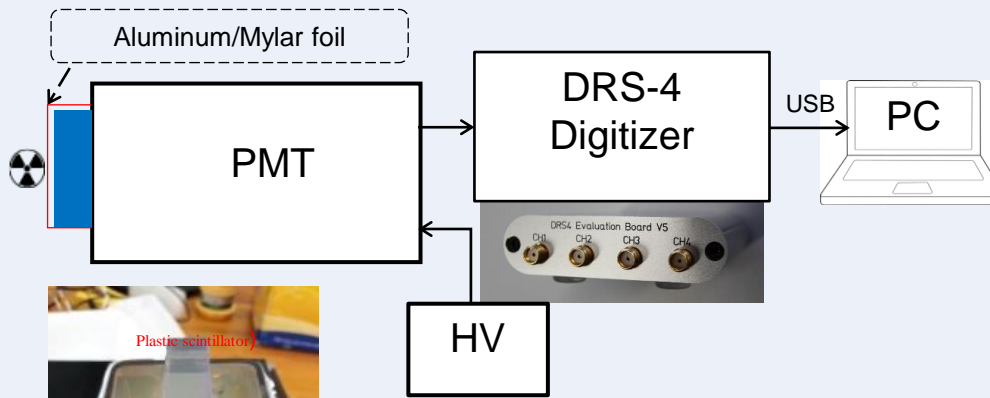

Scintillator: EJ-276, Eljen Technology. size: (14x14x40)mm³
PMT: R6236-01, Hamamatsu. Size: Square: 6cm x 6cm.
DRS-4 digitizer, Paul Scherrer Institute.
RI source: Gamma (Co-60) and Neutron/gamma (Cf-252)

Purpose

Optimization of Q_{ratio} means FOM largest.
→ Optimize the Q_{tail}
→ Theoretical evaluation is studied in this work and compare to previous study.

Q_{ratio} and FOM

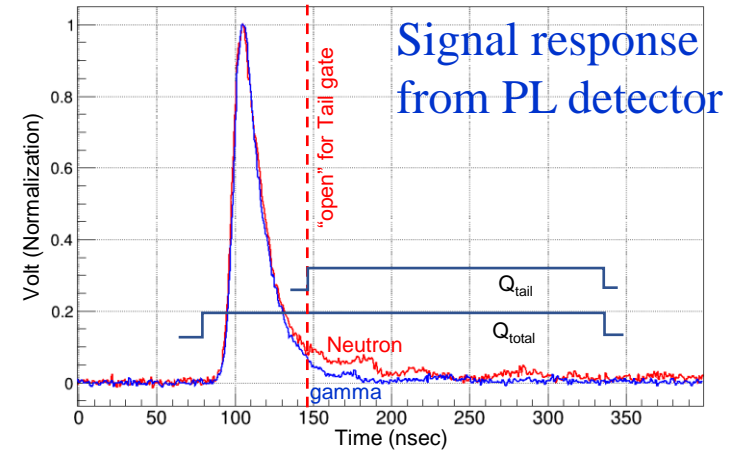

$$Q_{ratio} \text{ technique: } Q_{ratio} = \frac{Q_{tail}}{Q_{total}}$$

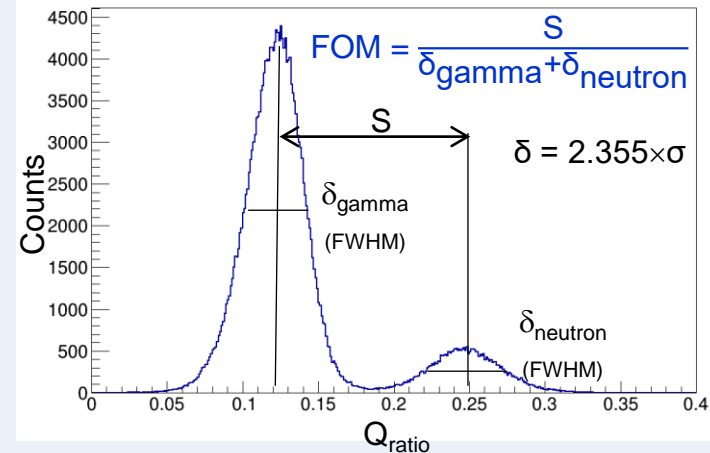

Calculation of signal response of a scintillation detector with 3 decay components

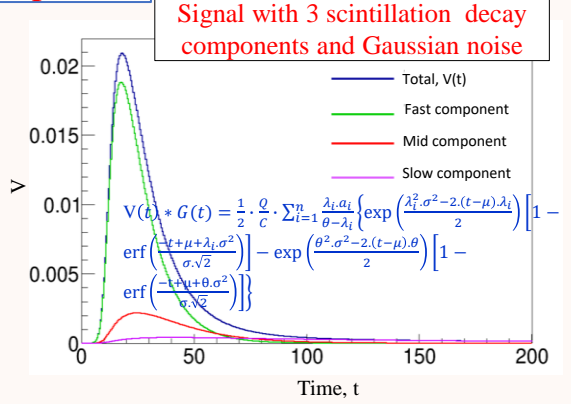
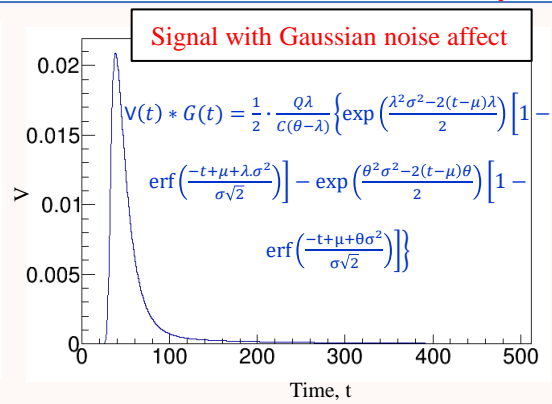
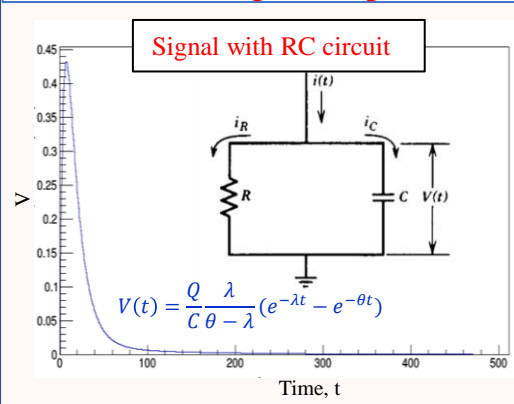

λ : Decay constant

$$G(t) = \frac{1}{\sigma\sqrt{2\pi}} e^{-\frac{(t-\mu)^2}{2\sigma^2}}$$

$$\theta = \frac{1}{RC}$$

$$\operatorname{erf}(x) = \frac{2}{\sqrt{\pi}} \int_0^x e^{-u^2} du$$

Data fitting

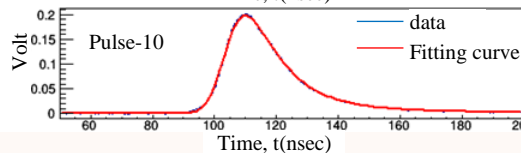
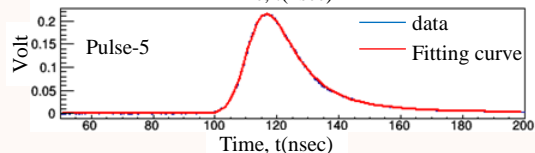
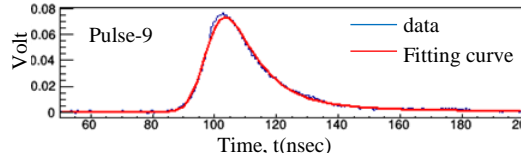
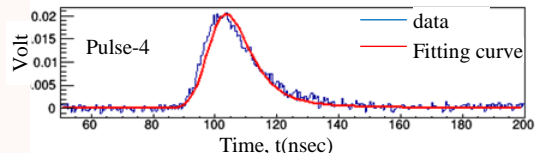
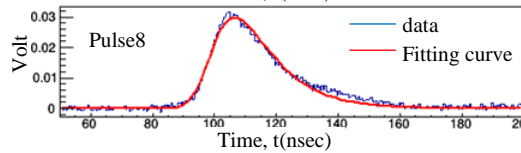
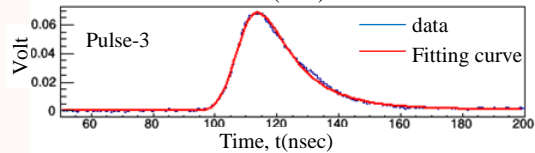
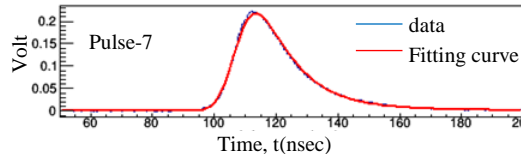
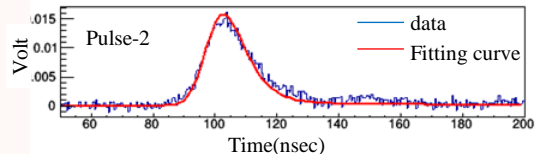
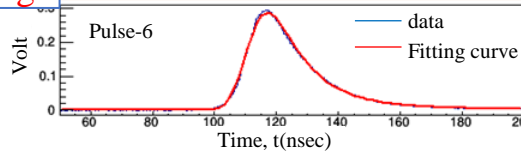
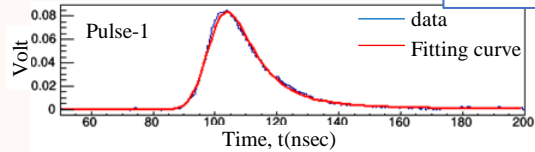

From measurement data for Co-60 and Cf-252



Fitting parameters	Gamma	Neutron
θ	0.124 ± 0.034	0.142 ± 0.048
λ_1	0.266 ± 0.075	0.328 ± 0.073
λ_2	0.055 ± 0.019	0.059 ± 0.019
λ_3	0.016 ± 0.010	0.009 ± 0.005

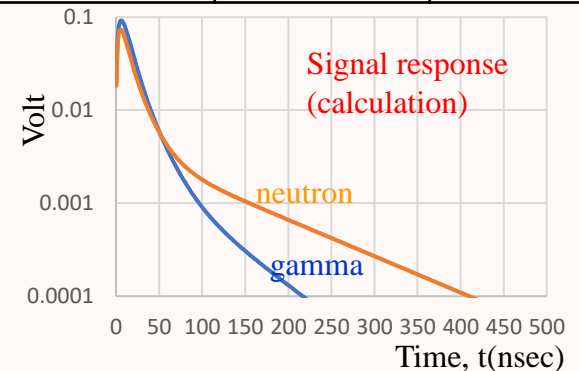

Fitting formula:

$$V(t) = \sum_{i=1}^3 A_i \left\{ \exp\left(\frac{\lambda_i^2 \sigma^2 - 2(t-\mu)\lambda_i}{2}\right) \left[1 - \operatorname{erf}\left(\frac{-t+\mu+\lambda_i\sigma^2}{\sigma\sqrt{2}}\right) \right] - \exp\left(\frac{\theta^2 \sigma^2 - 2(t-\mu)\theta}{2}\right) \left[1 - \operatorname{erf}\left(\frac{-t+\mu+\theta\sigma^2}{\sigma\sqrt{2}}\right) \right] \right\}$$

Fitting parameters: $A_1, A_2, A_3, \theta, \lambda_1, \lambda_2, \lambda_3, \sigma, \mu$.

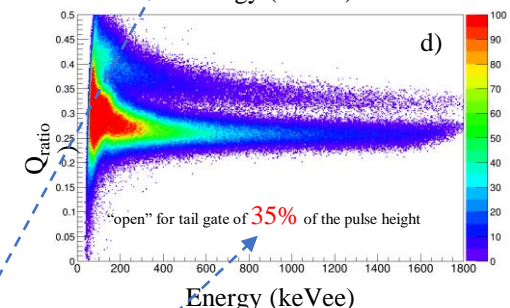
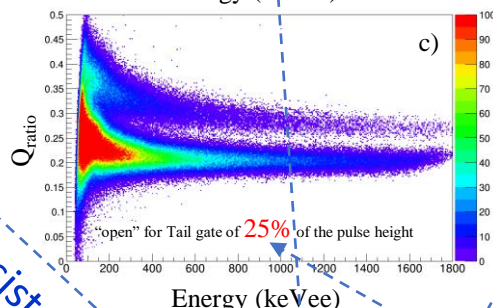
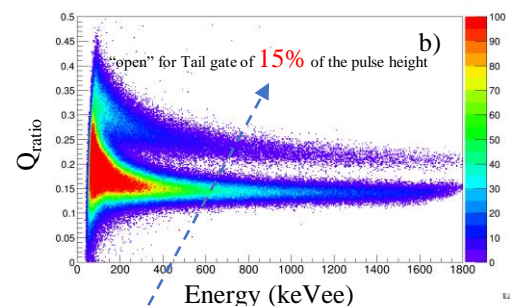
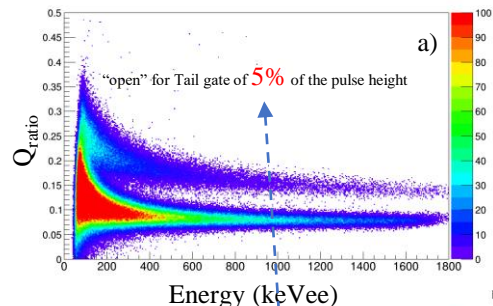
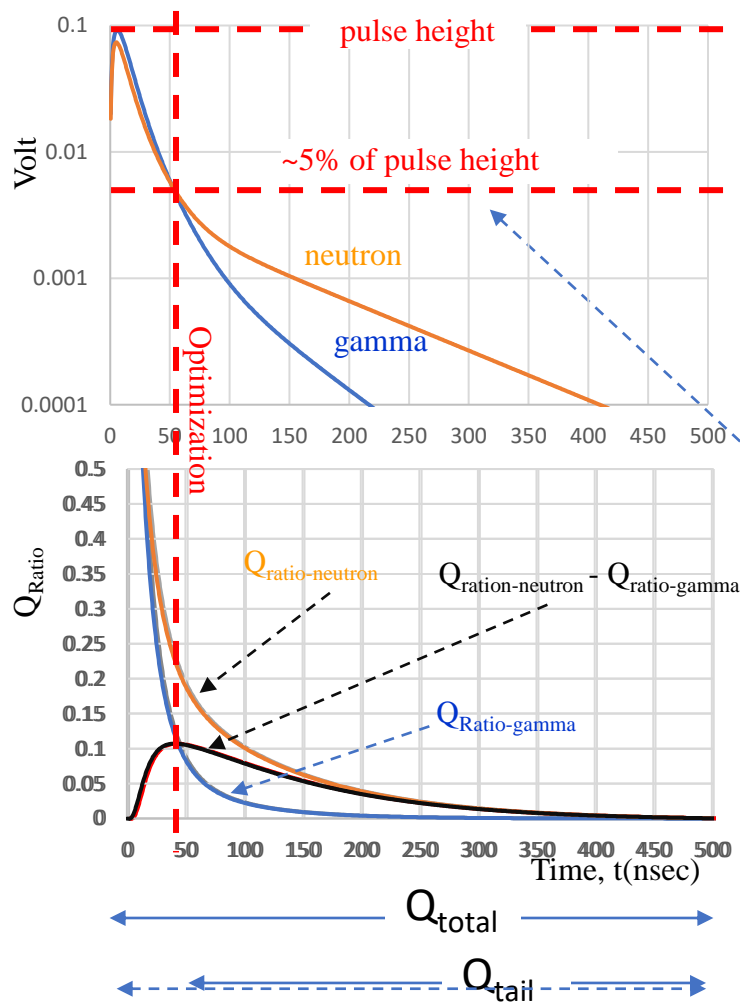

consistent

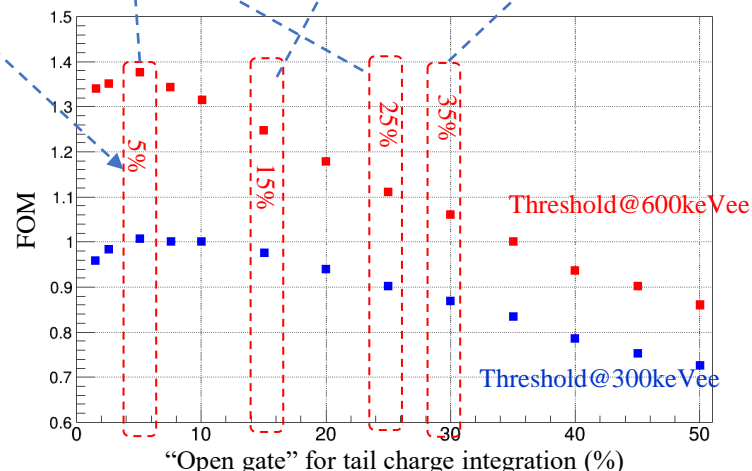

SUMMARIZE

- Equation to describe the pulse response for the EJ-276 scintillation detector with 3-decay components and gaussian noise.
- Determine characteristic parameters OF scintillation detector from measured data.
- Optimization of Q_{ratio} technique for neutron/gamma discrimination.