



Characterization of the magnetic shield efficiency for the ESS Double-Spoke cavities

SANSINE Vateanui

Institut de Physique Nucléaire d'Orsay

TTC/ARIES topical workshop 8th-9th of November 2018

The ESS project.

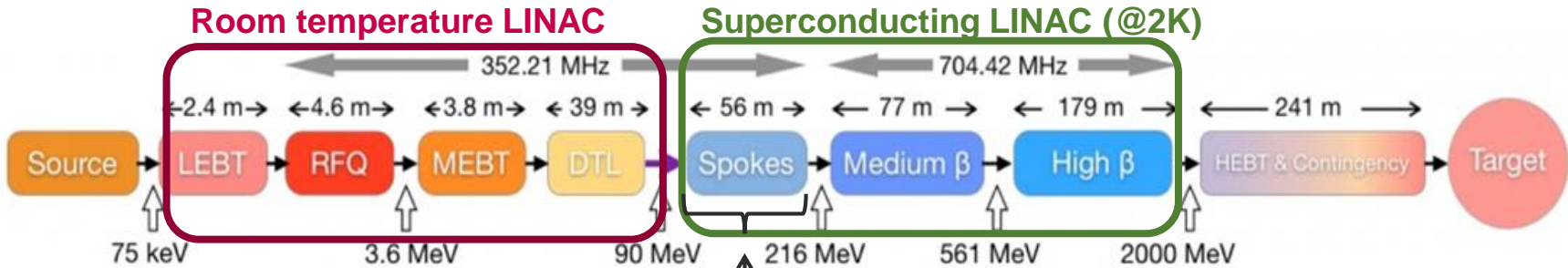

13 Spoke Cryomodules,
26 Double-Spoke cavities.

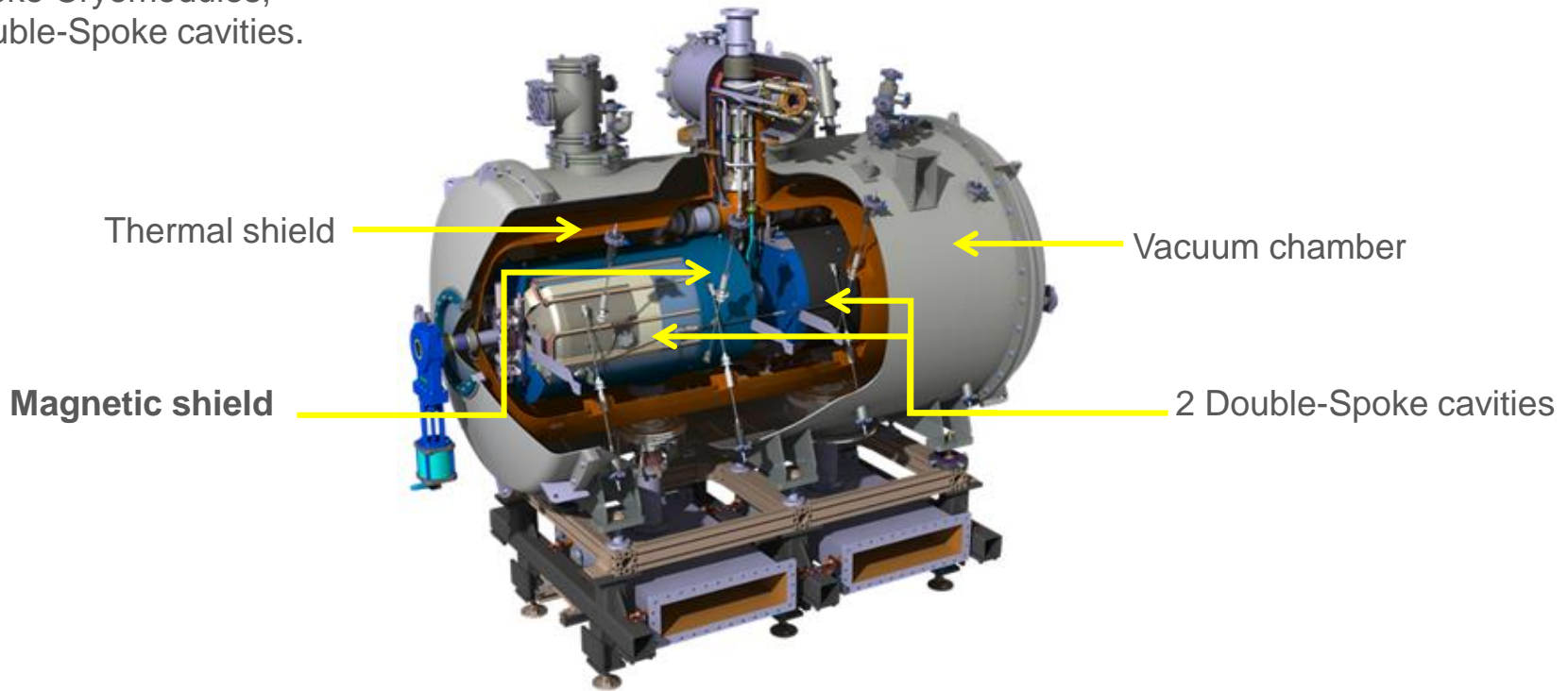

Prototype Cryomodule

Double Spoke Cavities

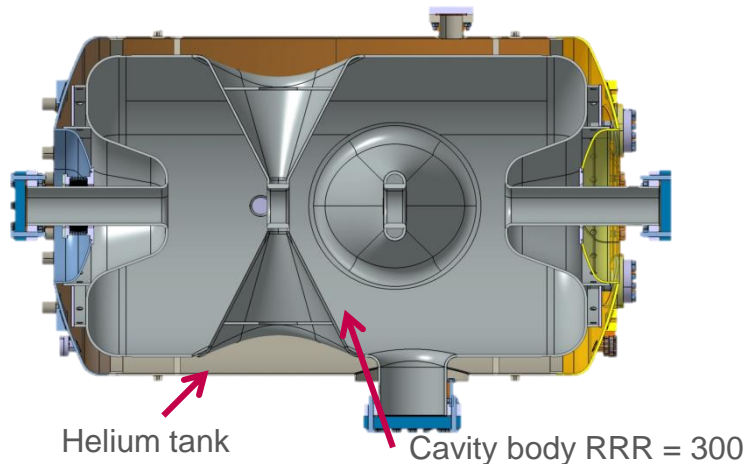

Cavity preparation:

- 2x Standard BCP (horizontal or vertical)
- 3x HPR
- Heat treatment at 650°C for 10h to limit trapped fluxes and be less sensitive
- Tested @ 4K and @ 2K in vertical cryostat
- Assembling in cryomodule

DOUBLE-SPOKE CAVITY

Frequency [MHz]	352.21
Beta_optimal	0.50
Operating gradient [MV/m]	9.0 (8.8)
Temperature (K)	2
Bpk [mT]	61
Epk [MV/m]	38
G [Ohm]	133
r/Q [Ohm]	427
Lacc (=beta optimal x nb of gaps x λ / 2) [m]	0.639
Bpk/Eacc [mT/MV/m]	6.8
Epk/Eacc	4.3
P nominal [kW]	335

Magnetic shield



What for?

- Reduces trapped flux
- Less residual losses during RF tests

What is it?

- $\mu_r = 10000$
- Cryophy®, Nickel-Iron alloy
- 2 layers, 1mm thick each

Goal

- Cold test of the magnetic shield
- Measure the attenuation versus temperature
- Determine if we need active cooling

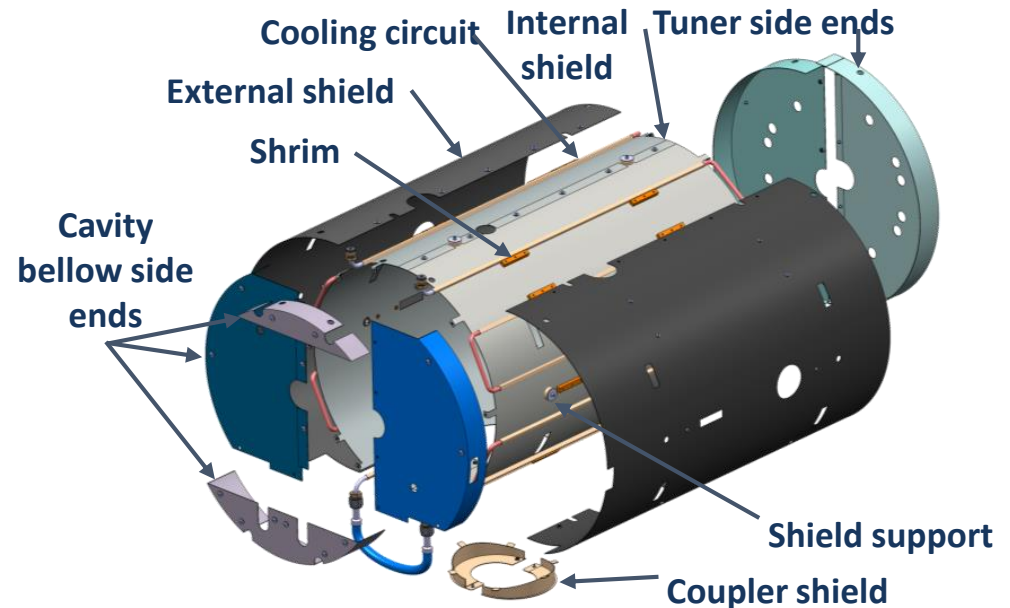

Initial design of the magnetic shield

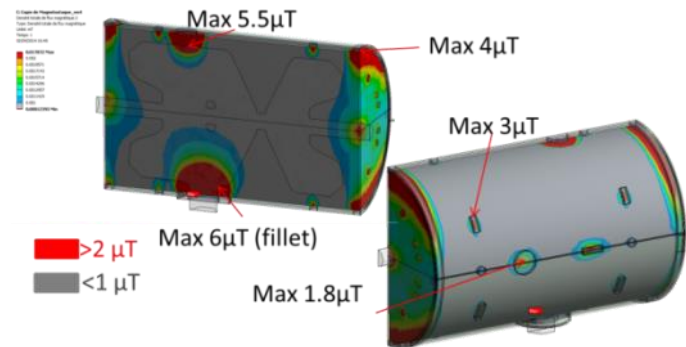

Simulation of the magnetic shield

Experimental set-up

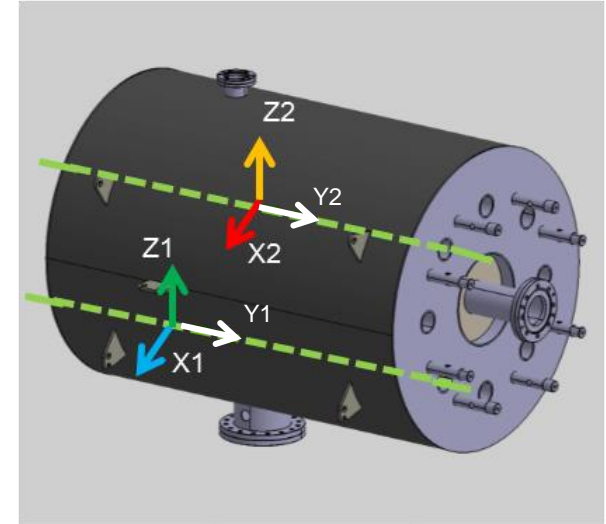
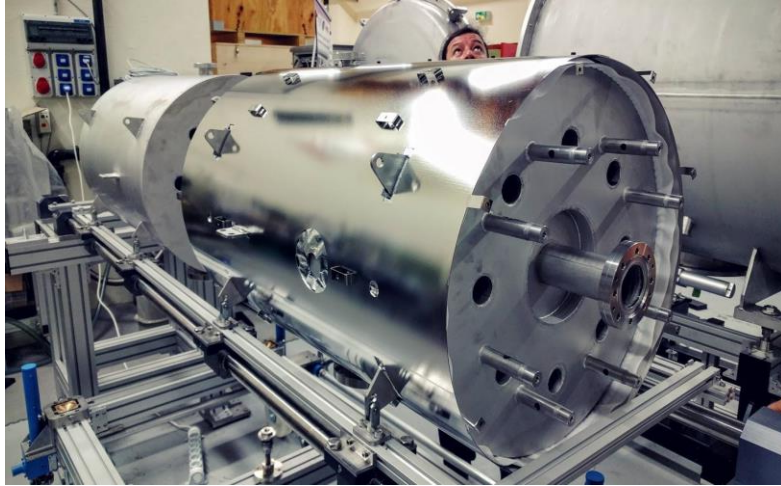

- Magnetic shield mounted around mock-up cavity
- Mock-up cavity made of SS 316L.
- Holes enable magnetic measurement inside the shielding

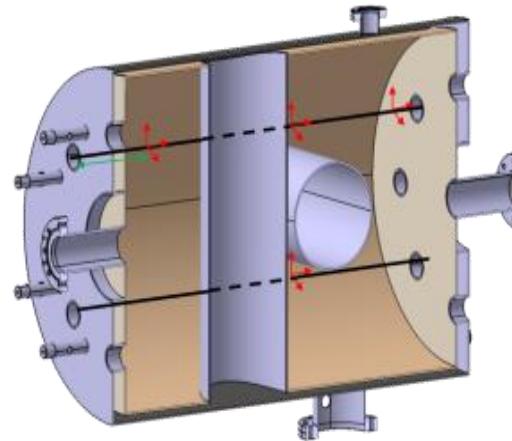

Protocol

- Set-up of the probes inside the mock-up cavity
- Magnetic shield around the cavity
- Assembling of the cryomodule
- Cryomodule set in the pit
- Cooling down with N2 and He



Bartington® Mag-01H
Single Axis Fluxgate Magnetometer
Measuring range: 0 to 2 mT
Maximum resolution: 0.1nT

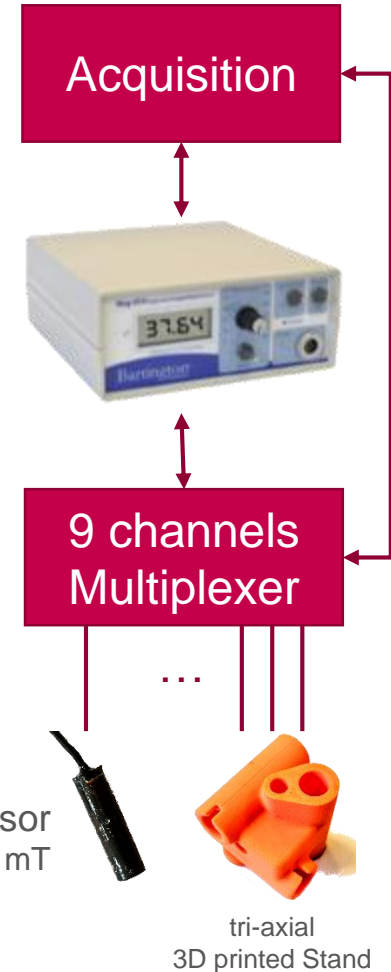

Results with LN2 coolant

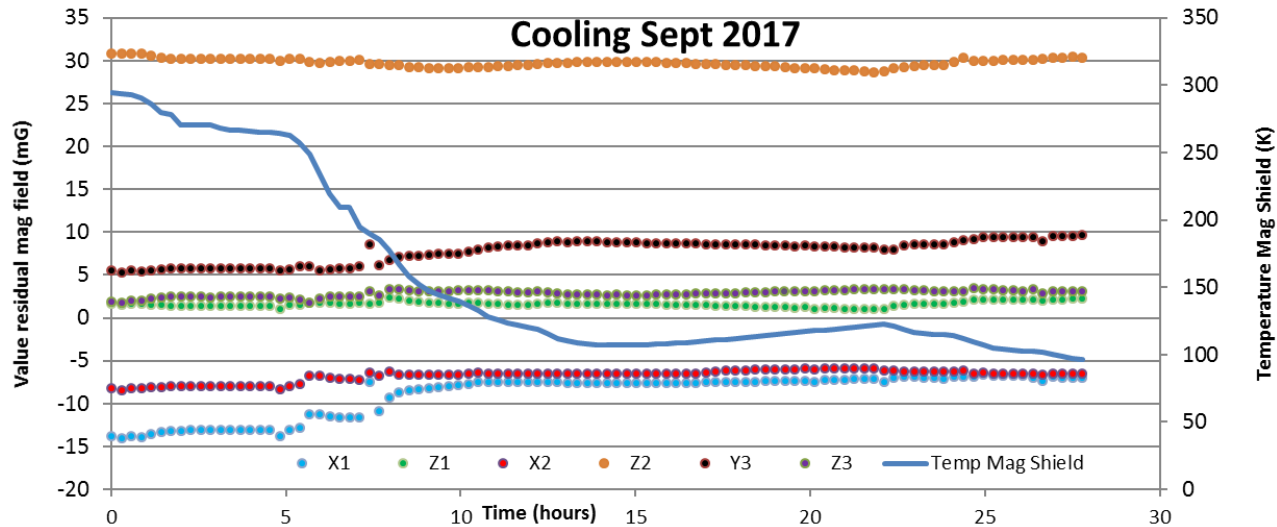
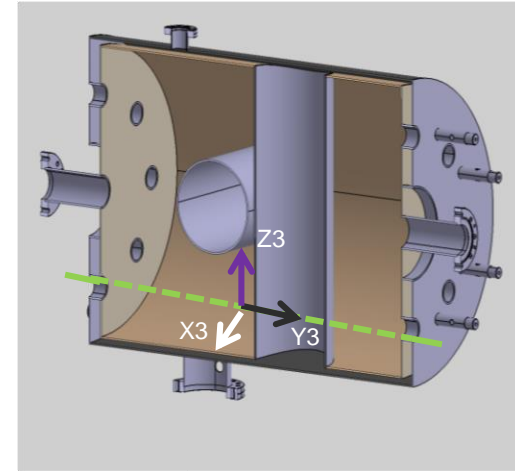
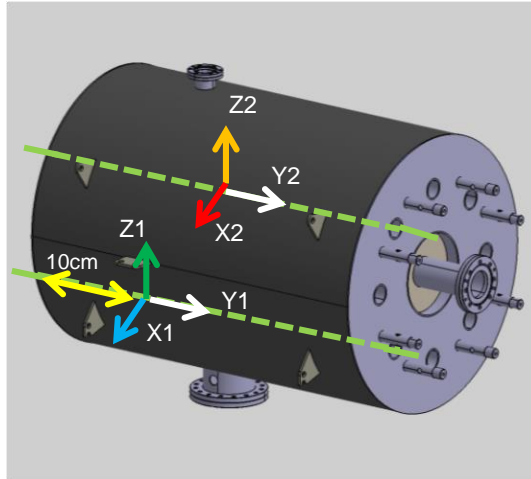

Results between 20-60K

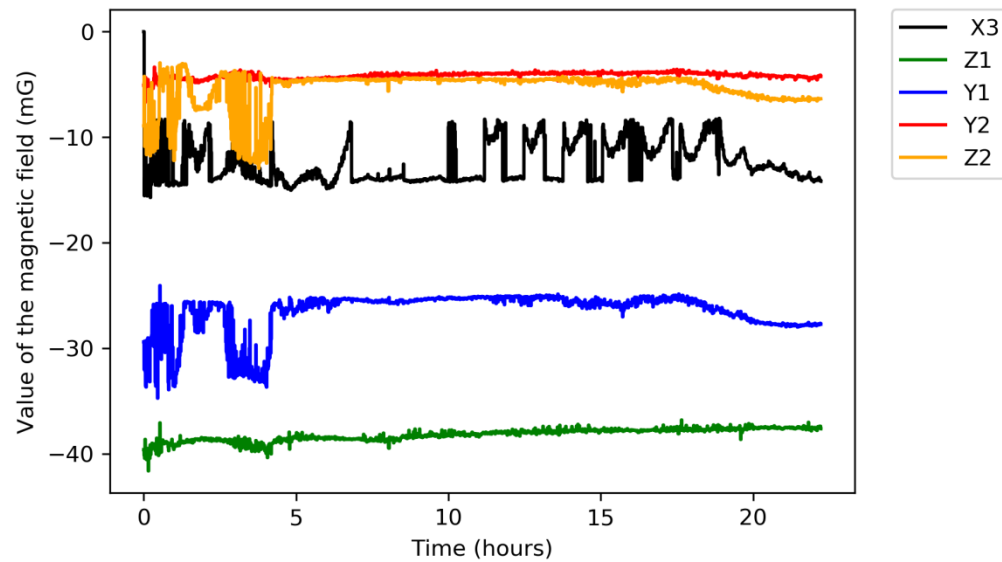
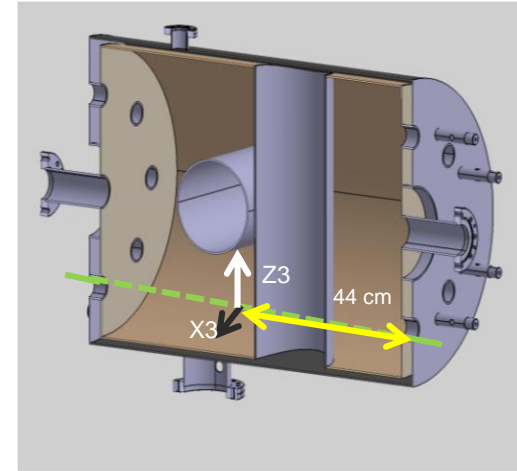
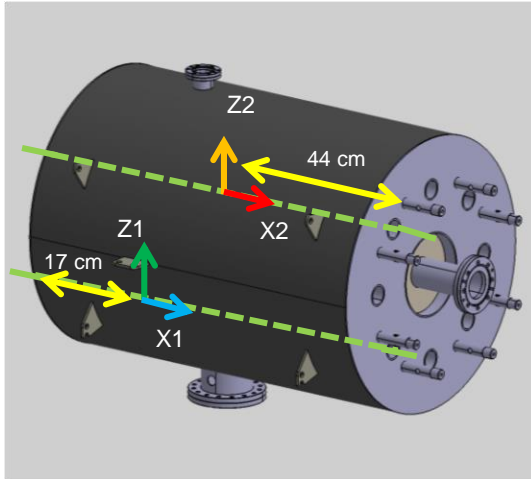

Conclusion



- No impact on the efficiency of the magnetic shield with LN2 and He
- No convection cooling but only passive cooling
- Next design: One layer of Cryophy of 2 mm thick for cryomodules and magnetic shield around the coupleur

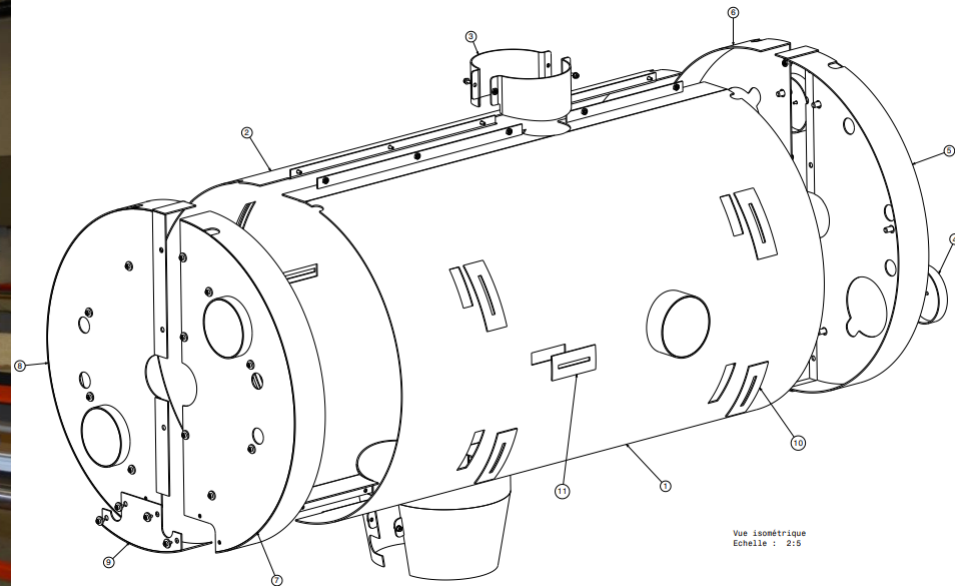
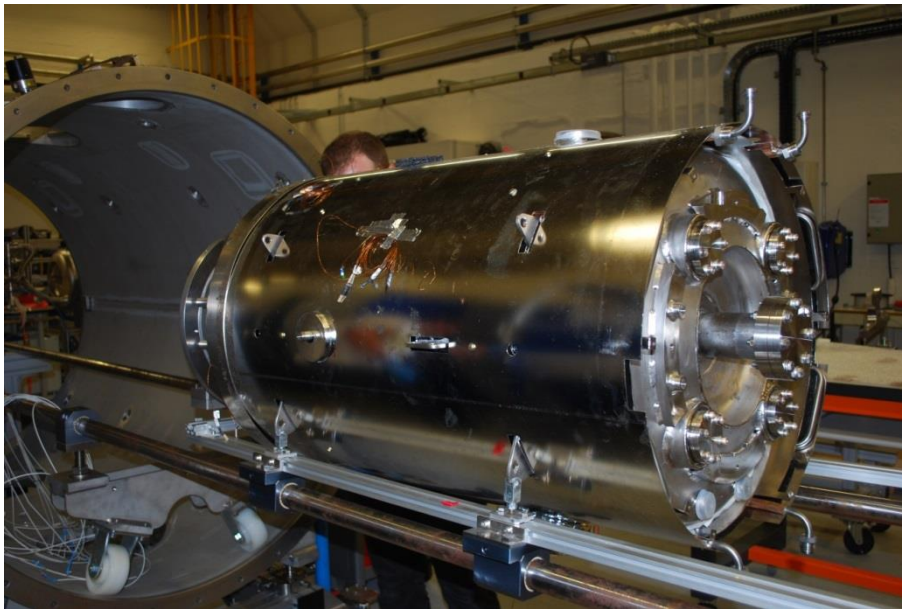



Thank you for your attention