

Next Generation RF BPM Development at NSLS-II



Next Generation Beam Position Acquisition and Feedback Systems

Workshop 2018

Nov 12-14, 2018

Dan Padrazo, Kiman Ha, Joe Mead, Weixing Cheng, Tony Caracappa

BNL, NSLS-II Diagnostics Group

Outline

1. Existing NSLS-II RFBPM overview
2. NSLS-II BPM upgrade to zDFE
3. AFE Upgrade Considerations
4. zBPM / APS-AFE Design status & Preliminary Performance
Test (Collaboration w/APS)
5. BbB BPM overview/status

NSLS-II BPM Performance Specifications

- Original NSLS-II development
- Resolution specs:
 - ✓ 1 μm turn-by-turn (TbT)
 - ✓ 200 nm in 10 kHz (FA)
 - ✓ Long Term Stability 200nm/8hrs in 10Hz (SA)
 - ✓ Verified with beam
- TbT used for injection & kicked beam studies
- FA for fast orbit feedback & interlocks
- SA for orbit measurements, System Health
- No bunch-by-bunch capability (cannot resolve bunches within a turn)

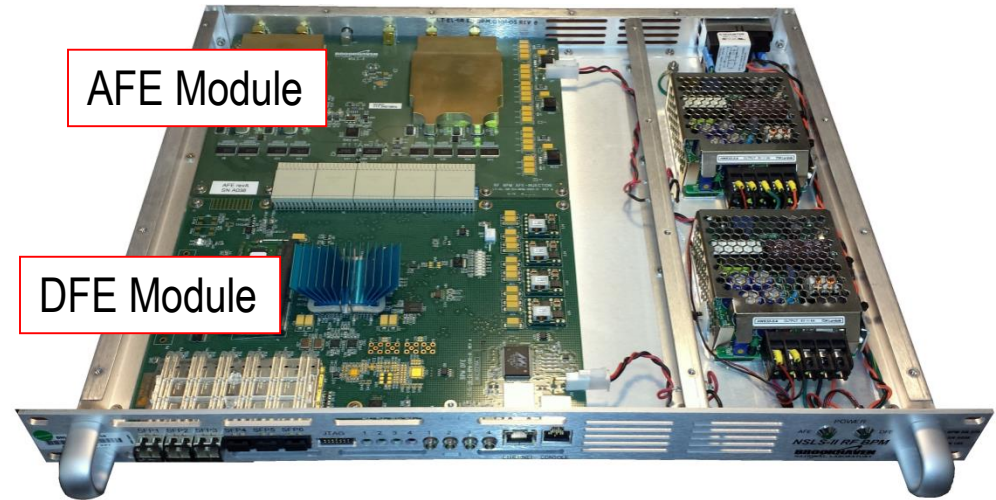

Data Type	Mode	Max Length
ADC Data	On-demand	256Mbytes or 32M samples raw ADC per channel simultaneously
TBT	On-demand	256Mbytes or 5M samples TbT (Frev=378KHz)
FOFB 10KHz	Streaming via SDI Link and On-demand	Streaming - X,Y,SUM ; For On-Demand: 256Mbytes or 5M samples FA (10KHz)
Slow Acquisition 10Hz	Streaming	DDR3 80hr Circular Buffer SA (10Hz)
System Health	Streaming 10Hz	DDR3 80hr circular buffer System Health; AFE temp, DFE temp, FPGA Die temp, PLL lock status, SDI Link status

Analog Front End Board (AFE)

- Architecture is based on under-sampling the 500MHz impulse response of band-pass filter.
- Coherent signal processing – ADC clock is locked to Frev.
 - 310 ADC samples per turn

Single Bunch @ 1mA

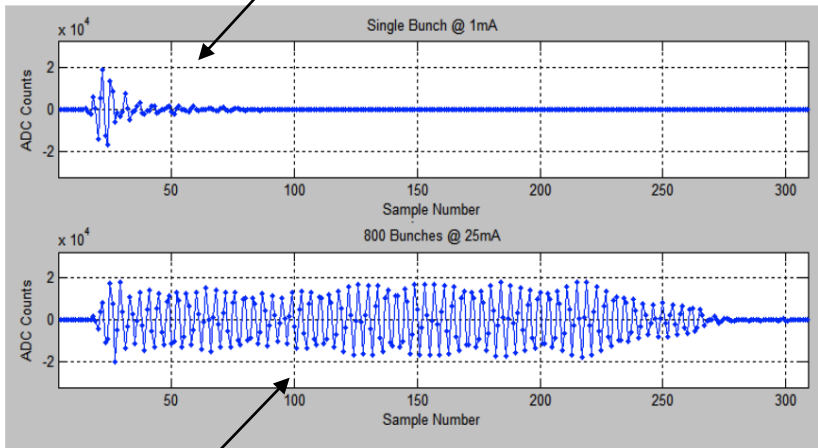

800 Bunches @ 25mA

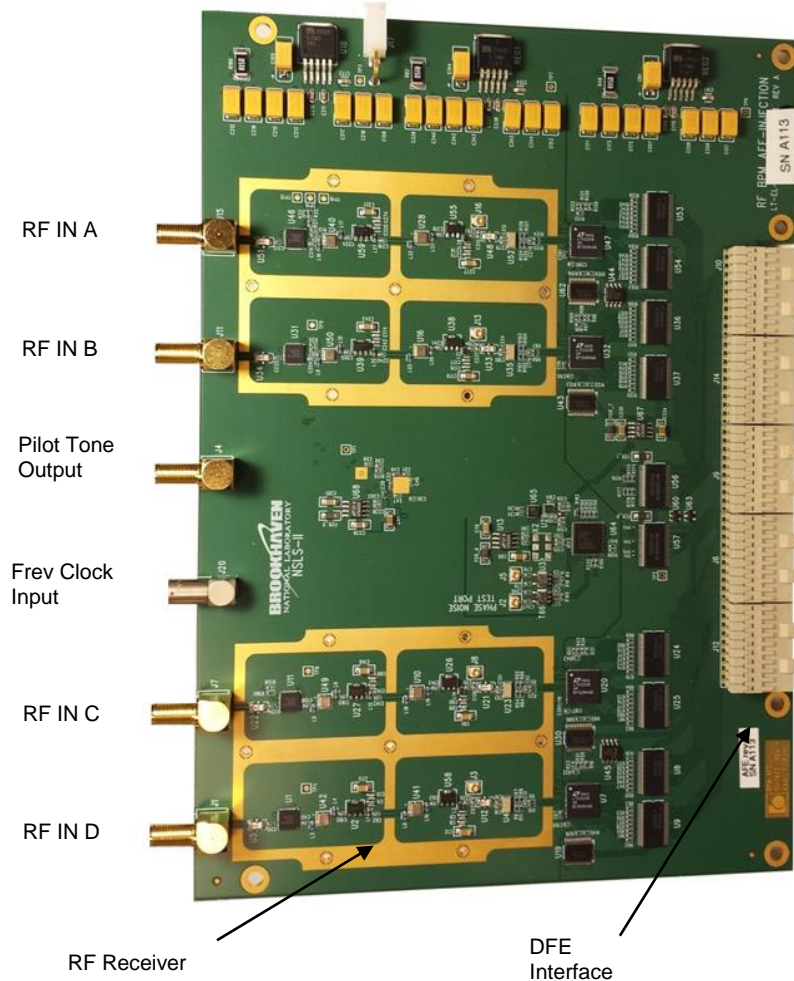

AFE RF Channel Signal Chain

Single Channel Signal Chain

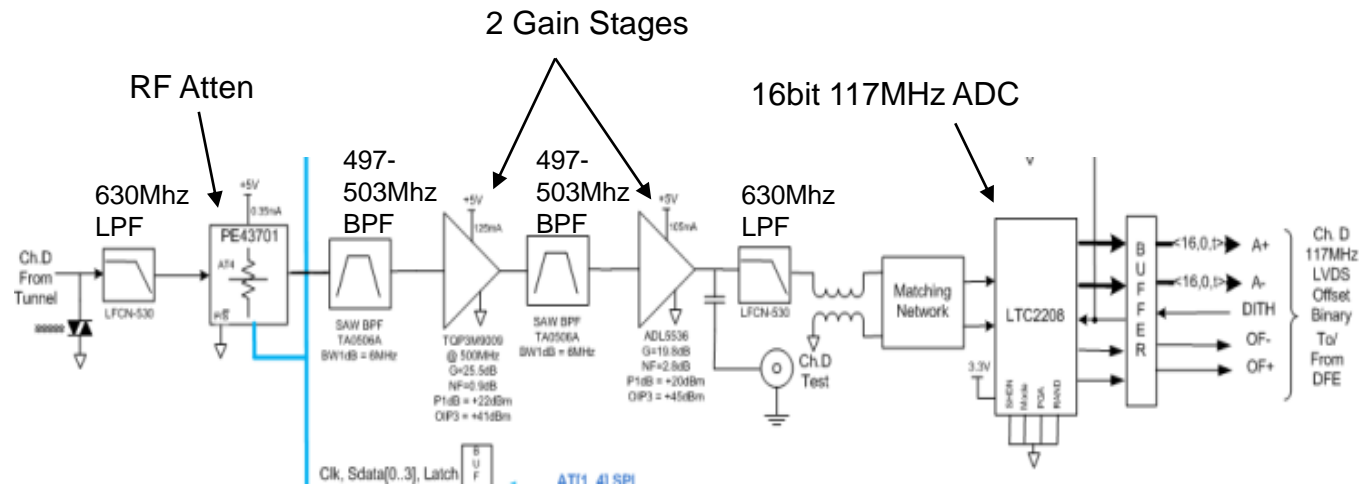

Digital Front End Board (DFE)

Features/Benefits:

- Xilinx Virtex-6 FPGA (LX240T)
- DFT algorithm for beam signal processing
- FW support for DFT, CIC, & FIR for 10kHz
- Embedded MicroBlaze soft core μ P
 - Xilkernel OS and lwIP TCP/IP stack
- Gigabit Ethernet
- 2Gbyte DDR3 Memory (SO-DIMM Module)
 - Memory throughput = 6.4 GBytes/sec, which is fast enough to support streaming raw ADC data.
- Six 6.6Gbps SFP modules
 - Embedded Event Receiver
 - Fast Orbit Feedback
- 768 Hard Multipliers in FPGA fabric – Used for FIR filters, position calculations, etc.
- 1Gbit FLASH memory
- Also used as ‘cell controller’ processor for Fast Orbit Feedback
- Supports two(2) Gate signal processing function (Beam Operation, online lattice characterization)
- Multiple sinewave driving for fast/slow corrector excitation (0-2 kHz sinewave drive via global & SDI links)
- Post Mortem (ADC sum, TBT: X,Y,Sum, FA: X,Y,Sum)
- TBT Glitch Detection

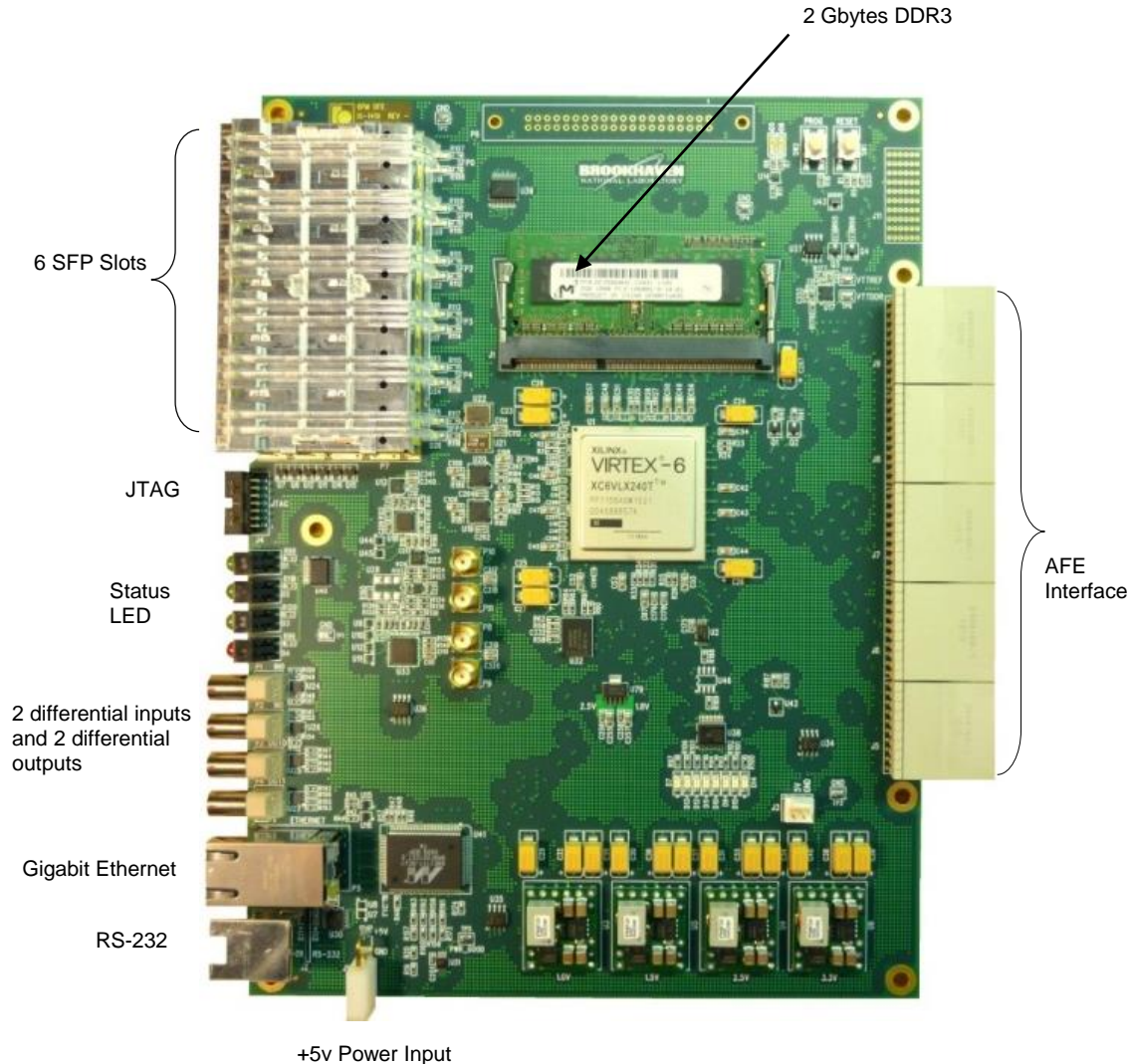

Motivation for BPM Upgrade to zDFE

Deficiencies of existing RF BPM DFE

- The soft-core MicroBlaze processor has limited performance and poor network performance (<20Mbit/sec).
- Xilkernel OS is a non-standard, Xilinx specific, bare-metal operating system with limited support.
- LwIP TCP/IP stack has some reliability issues.
- Software development requires special knowledge of Xilinx kernel OS features and therefore steep learning curve and difficult to maintain as opposed to standard OS such as Linux.
- Hardware obsolescence, existing technology is 9+ years old

zDFE Improvements vs. Existing RFBPM DFE

- Hard dual-core ARM A9 processor provides >500Mbit/sec throughput. This is a 25x improvement over the existing RFBPM DFE performance.
- Runs standard Debian-7 based Linux Operating System.
- Embedded IOC
- Boot via 32Gbyte micro SD-Card
- DMA Kernel driver for large waveform access
 - Up to 300Mbyte
- Software development is now standard user space applications similar to software development on a standard linux server.
- Long term maintainability and standard software development provide quick learning curve and allow developers easier access to maintain and upgrade software and features.
- Added FPGA resources supporting:
 - Multi-gate signal processing
 - Digital signal processing (DFT, DDC)
 - Single bunch multi harmonic processing for improved resolution

Digital Front End Board (zDFE)

Features/Benefits:

- Faster processing and networking, 500Mbit/sec vs. 10Mbit/sec
- Hardware is backward compatible, use existing AFE and enclosure to minimize upgrade effort and cost
- Standardize to common DFE platform, supporting multiple sub-systems including: RFBPM, BbB-BPM, X-Ray BPM, Cell Controller for Fast Orbit Feed-Back
- Runs standard Debian based Linux Operating System.
- Software development is now standard user space applications similar to software development on a standard linux server.
- Support for Bunch-by-Bunch position calculation
- Integrated 10Gbps transceivers to interface to 500MSPS ADC's

Expansion Connectors
For PID interface

Expansion Connector for
future Bunch-by-Bunch
BPM
(8 - 10Gb/s links)

6 SFP

8 Status
LED's

SDCARD

Single-ended
I/O

GigE

Serial
Port



AFE Interface

zDFE BPM Performance Specifications

- zBPM Prototype
- Resolution specs:
 - ✓ 1 μm turn-by-turn (TbT)
 - ✓ 200 nm in 10 kHz (FA)
 - ✓ 200nm Long Term Stability /8hrs in 10Hz (SA)
 - ✓ Verified with beam
- TbT used for injection & kicked beam studies
- FA for fast orbit feedback & interlocks
- SA for orbit measurements, System Health

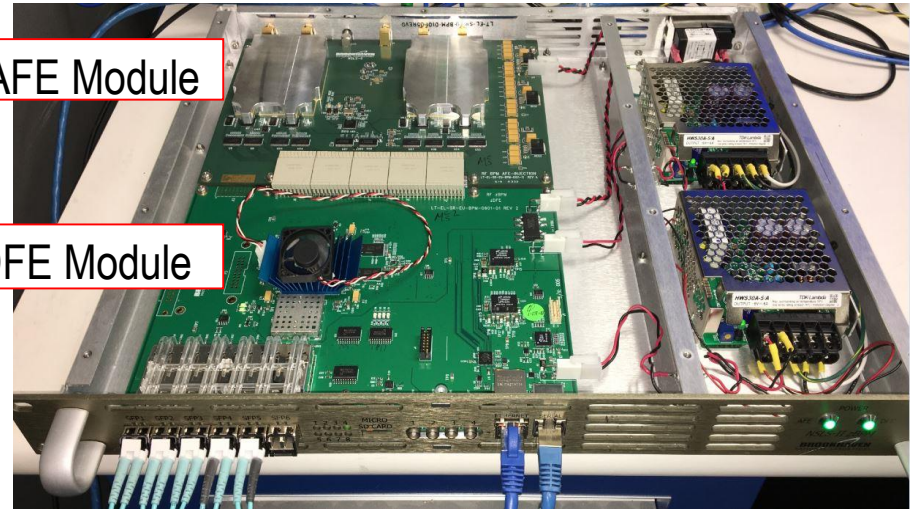

Data Type	Mode	Max Length
ADC Data	On-demand	100Mbytes or 12M samples raw ADC per channel simultaneously
TBT	On-demand	100Mbytes or 2M samples TbT (Frev=378KHz)
FOFB 10KHz	Streaming via SDI Link and On-demand	100Mbytes or 2M samples FA (10KHz) Streaming - X,Y,SUM ; On-Demand:
Slow Acquisition 10Hz	Streaming and On-demand	SD Card based 80hr circular buffer SA (10Hz)
System Health	Streaming	SD Card based 80hr circular buffer System Health; AFE temp, DFE temp, FPGA Die temp, PLL lock status, SDI Link status

Upgrade Considerations for AFE

- Temperature Control
 - Present use of temp control racks (+/- .1deg C)
 - Achieve 200nm long term stability
 - 1 – 3 um/degree C
 - Investigate use of Peltier cooling for temperature regulation
 - Eliminate dependence on temp control racks
- RF Switching
 - 4-way switch presently implemented in Libera B+
 - Achieve <50nm long term stability
 - 2-Way switch presently implemented in the Sirius BPM
 - Diagonal switch simplifies application
 - Achieve <50nm long term stability
 - NSLS-II New AFE Design implementation of 2-Way switch
 - Diagonal switch simplifies application
 - Achieve <50nm long term stability
 - Collaboration with APS, Brazilian LS
- Pilot Tone
 - Presently design custom diplexer developed by K&L Microwave for injection and combining of Out-of-Band Pilot-Tone
 - Temperature dependent band pass response of existing SAW filters on RFBPM AFE, prevented successful implementation.

zBPM System Integration Test Config

MC28RG-G1 BPM Development Rack

- Temperature Controlled to .1 degC
- Standard NSLS-II Timing System
- Dedicated PUE for testing
- Dedicated NSLS-II Cell Controllers

Mobile Cell RF Switch Prototype Test

Instrument RFBPM AFE w/external RF Switch box
Diagonal Button signals switch (A/C, B/D)

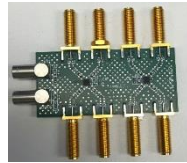

Mobile Cell

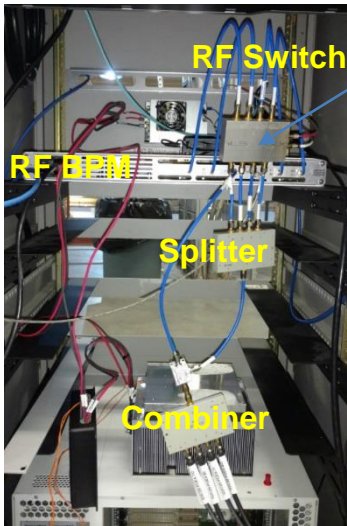

MC28RG-G1



Diagnostics R&D C28

Development Setup

Version 5, M. Maggipinto
11/9/2018

LI	Device	Description	IP	User	Password	Moxa IP	Moxa Port
1	28-15	V6 BPM	10.0.142.233			10.0.132.42	4004
2	ZBPM-69	ZYNQ BPM	10.0.153.69			n/a	n/a
3	B+	Libera Brilliance +	10.0.143.195			n/a	n/a
4	ZBPM-1	APS BPM	10.0.153.29			n/a	n/a

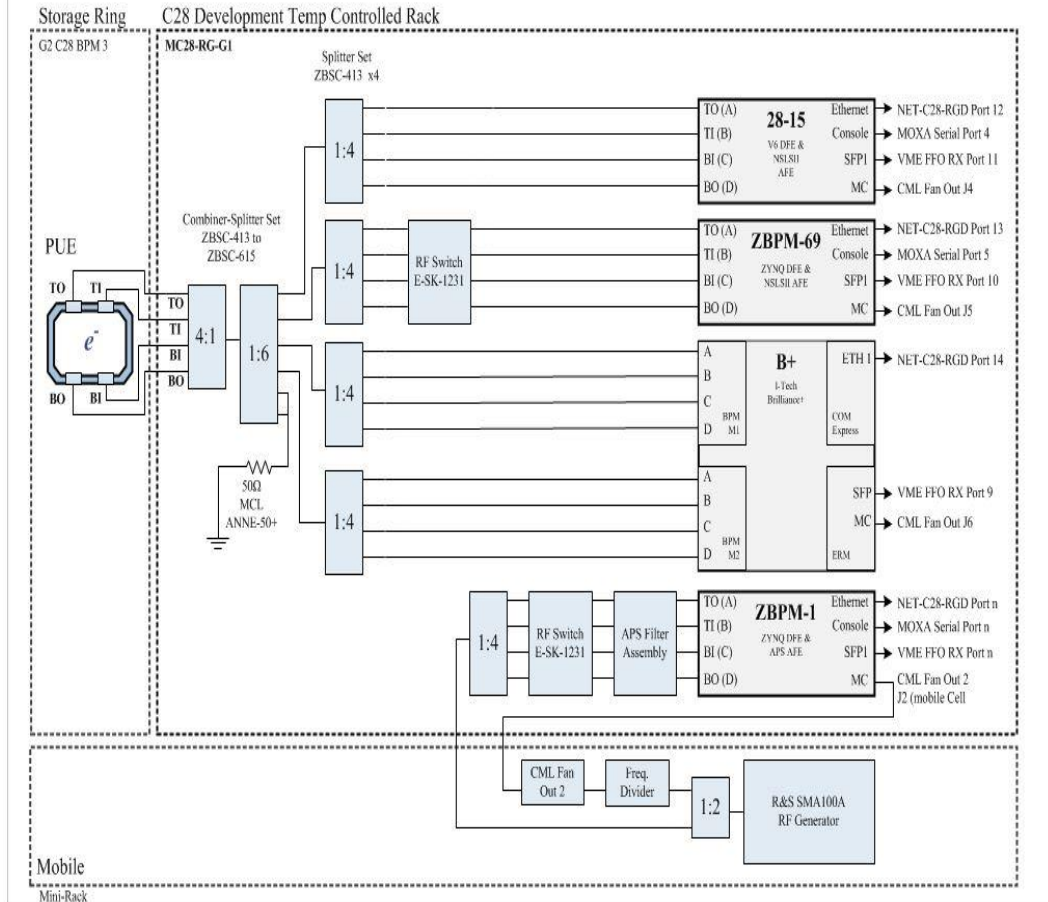

FA 10 kHz PSD plot

Short-term stability

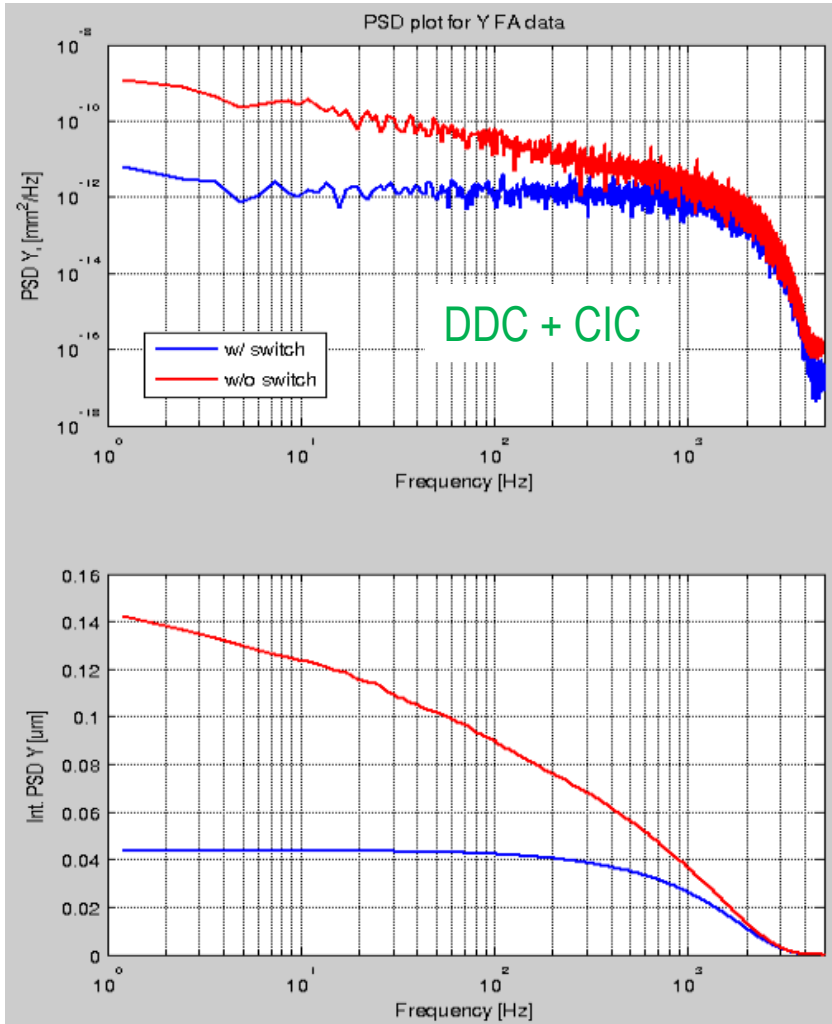

- FA 10 kHz PSD plot
- With RFSW switching (Blue)
- Without switching (Red)
- W/O RFSW switching, FA achieve 140nm
- W RFSW switching, FA achieve 40nm

W. Cheng

Long-term Test result (2-Days)

- V6 BPM existing BPM (red: 130/126 nm)
 - Installed temperature controlled rack (+/-0.1 degree C)
- zBPM (blue: 10.5/20.0 nm)
 - Mezanine area temperature (+/-0.5 degree C)
 - Diagonal RF switching enabled
- Both are the same pick-up signal from button->combiner->splitter)
- Beam 400 mA

W. Cheng

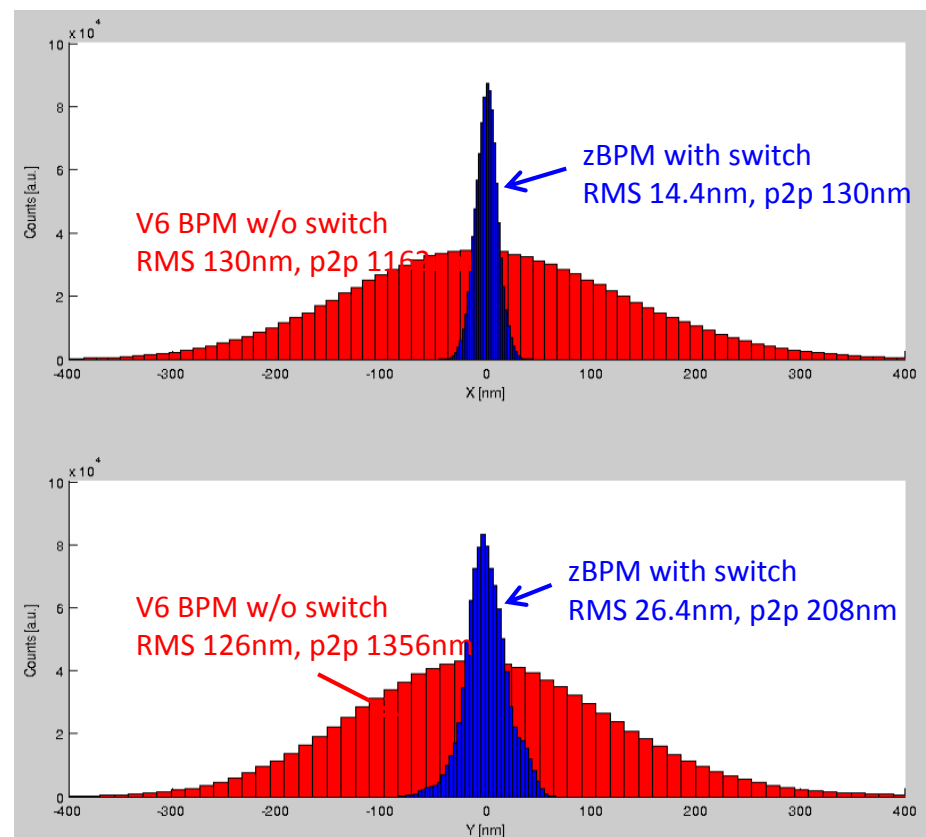
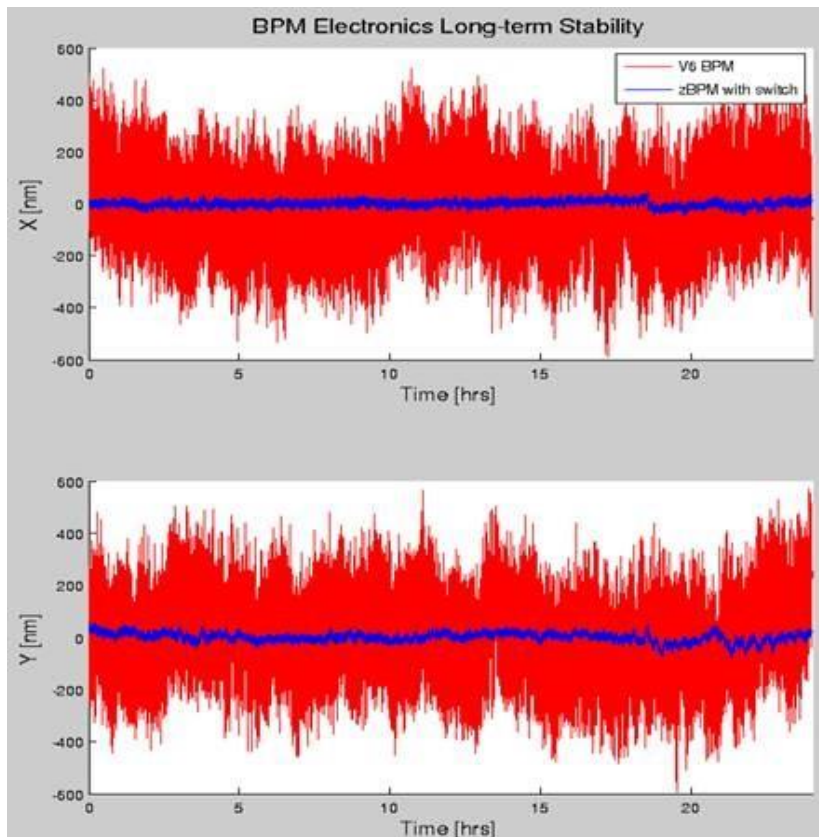

CSS Top Panel SA 2kSec (w/Switch)

File Edit Search Run CS-Studio Window Help

zbpm_sr_start.opi SR{BPM:069}SA:Gate1

SA:G1 SA:G2 SA:PT(HI) SA:PT(LO) Diagnostics ADC TbT:G1 TbT:G2 FA:G1 FA:G2 SDI

X Position (um) vs Samples

Y Position (um) vs Samples

Y Position (um) vs X Position (um)

N Samples: 100, 200, 500, 1000, 2000

Beam Scale and Offset	Level	PT Freq	PT Atten	SA	Readings	Sigma	Phase
Kx: 10000000, 10000000	A B	Rotational Harmonic: 0.00	15	A	0.066631	0.000001	0.000000
Ky: 10000000, 10000000	D C	499.6800 MHz	PT Pwr: ON	B	0.065403	0.000001	0.000000
Xoff: 0, 0	BPF		RF Atten: 18	C	0.066525	0.000001	0.000000
Yoff: 0, 0	IN Bypass			D	0.065519	0.000001	0.000000
View SA Data for A, B, C, D, Sum				S	0.264078	0.000004	RMS
				X	6.470	0.002	6.469
				Y	-0.240	0.002	0.242
				A(Q)	0.000000		
				A(I)	0.000000		
				SA Trig Count	36043		
				SA Timestamp			
				Sec	1536867550	nSec	95474637
				Trigger Delay	0 ns		
				GEO Width	2633.15 nsec		
				GEO Delay	0.0 nsec		
				Event Num	32	Soft Trig	
				Gate2 Width	2633.15 nsec		
				Gate2 Delay	0.0 nsec		
				Trigger Timestamp			
				Sec	1536867550	nSec	31824814
				Trigger Count			
				All	2896	Soft	0
				PLL	LOCKED		

RMS 2 nm

Look Ahead: Next Generation AFE

- RF BPM AFE Development
 - ✓ Support Active (PT Based) Calibration (Possible to Collaborate with ALS)
 - ✓ Implement 2-way Analog switching
 - ✓ Non-Dependence on Temperature controlled rack
 - ✓ Improve Long Term Stability

- RF BPM DFE Development
 - ✓ FPGA upgrade to Xilinx Zynq UltraScale+

- BbB zAFE Development
 - ✓ 500Msps 14/16 Bit ADC(ADS54J66,ADS54J69) resolve bunches within a turn (BbB position data)

RF BPM APS AFE Prototype

zDFE/AFE BPM Chassis

AFE Prototype

zDFE

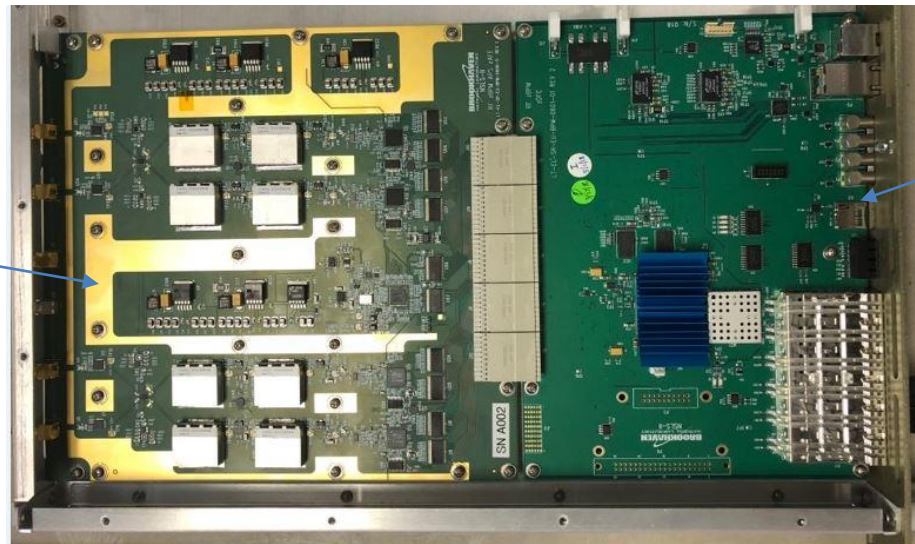

APS-AFE Prototype Block Diagram

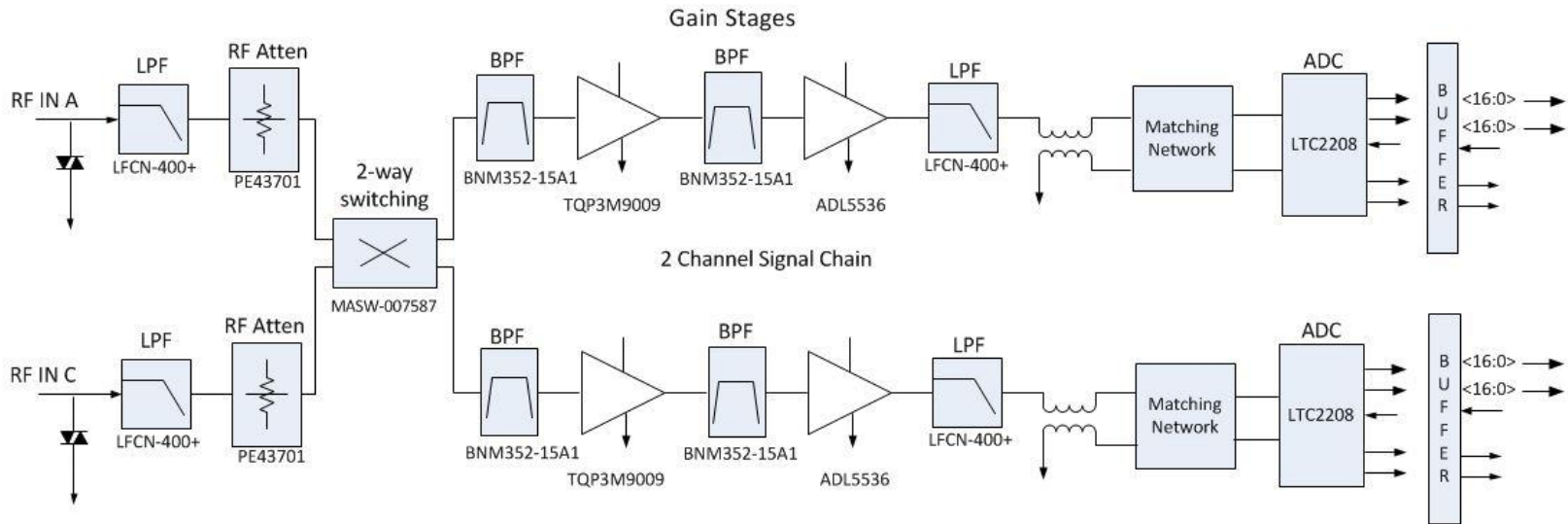

BbB BPM Electronics

- **Motivation is to design a single BPM electronics module that can simultaneously perform bunch by bunch position measurements while also improving turn by turn position results over traditional subsampling architectures.**
 - Strong physics interest for BbB capability at multiple BPM locations.
- **Due to advances in ADC technology in the past few years this is now possible.**
 - TI AD54J66: Quad Channel, 14-bit, 500Msps ADC (\$600)
 - TI ADS54J69: Dual Channel, 16-bit, 500Msps ADC (\$600)
- **Latest advances in FPGA technology could provide single chip solution**
 - Xilinx RFSoc FPGA : 8 channel, 12-bit, 4Gsps.
 - Xilinx 2nd Gen RFSoc FPGA : 8 channel, 14-bit, 5Gsps

BbB Evaluation Results

- Hardware for evaluation was TI ADS54J66 (Quad 500Msps,14-bit ADC) evaluation board connected to a Xilinx Zynq ZC706 evaluation board.
- Beam Test with 325mA user beam, 1000 bunches (0.3mA bunch current)
- Combiner / splitter setup to remove beam motion, +20dB amplifier before ADC

~5um BxB position resolution

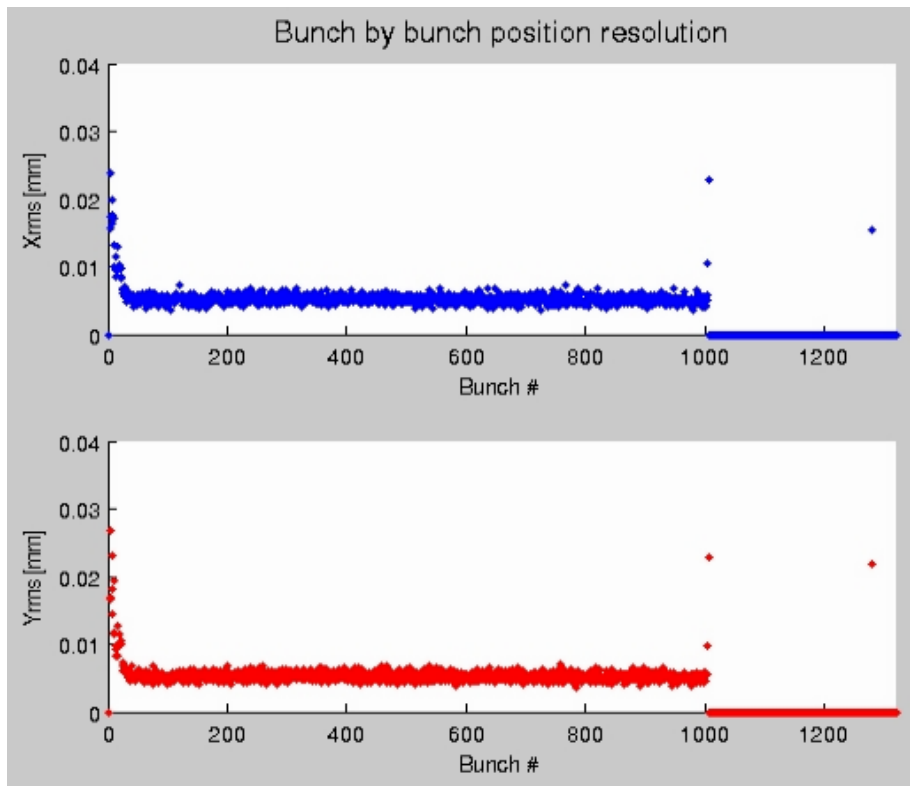

~0.6um Tbt position resolution

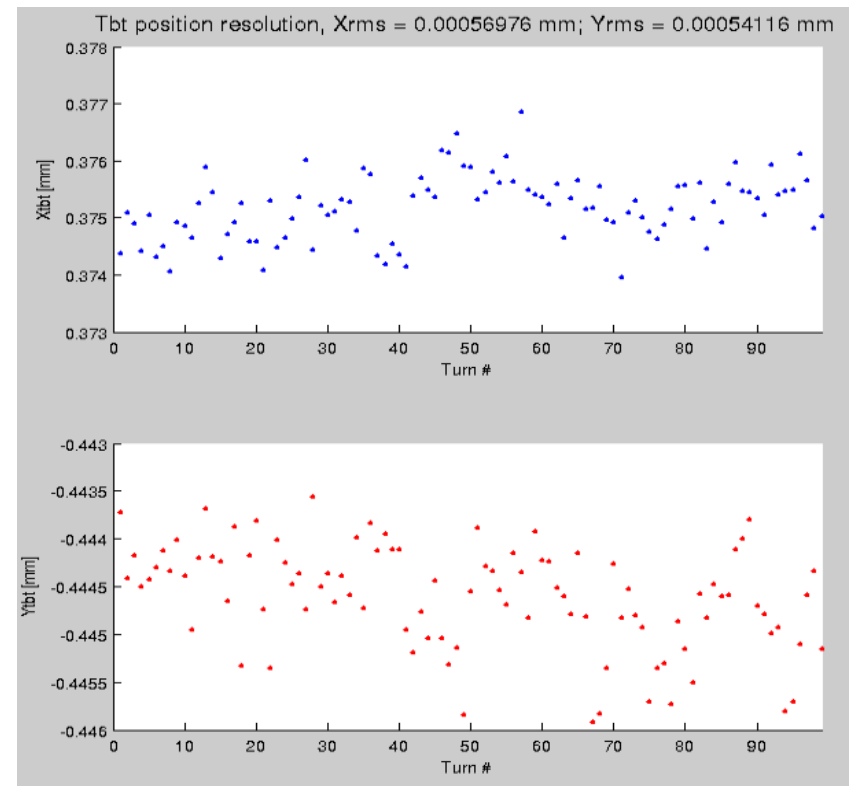

BbB Hardware

- Based on promising preliminary results with evaluation hardware, decision to move forward with custom hardware
 - RFFE Front end board
 - Digitizer Board (pcb in fabrication)
 - 4 channel 500Mps ADC
 - 4 channel 500Mps DAC (for possible feedback)

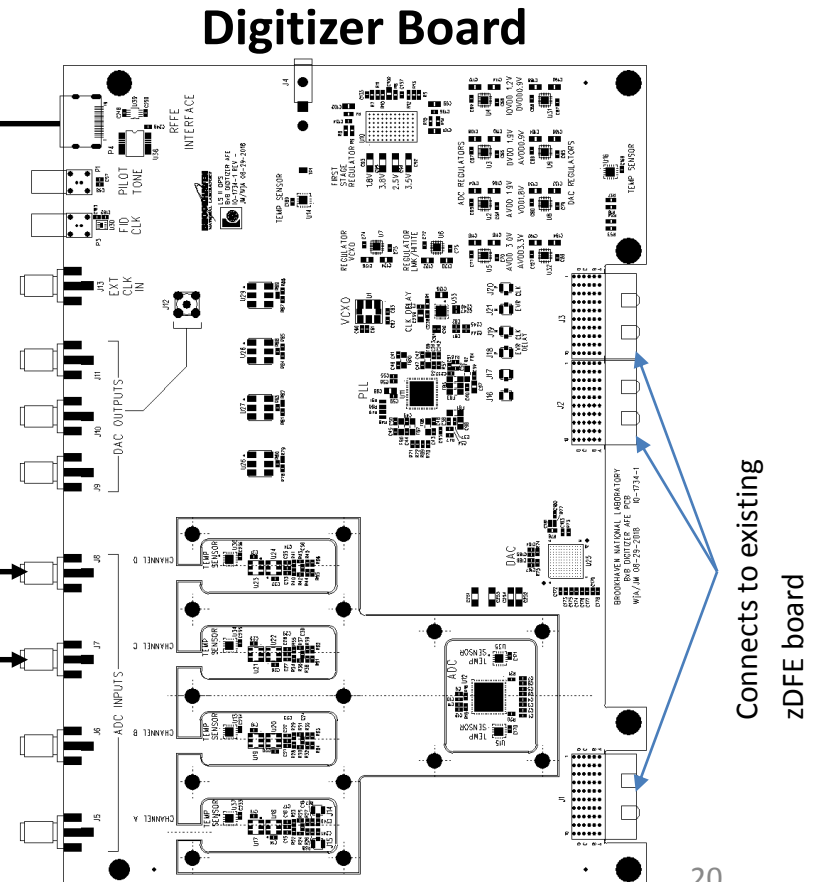
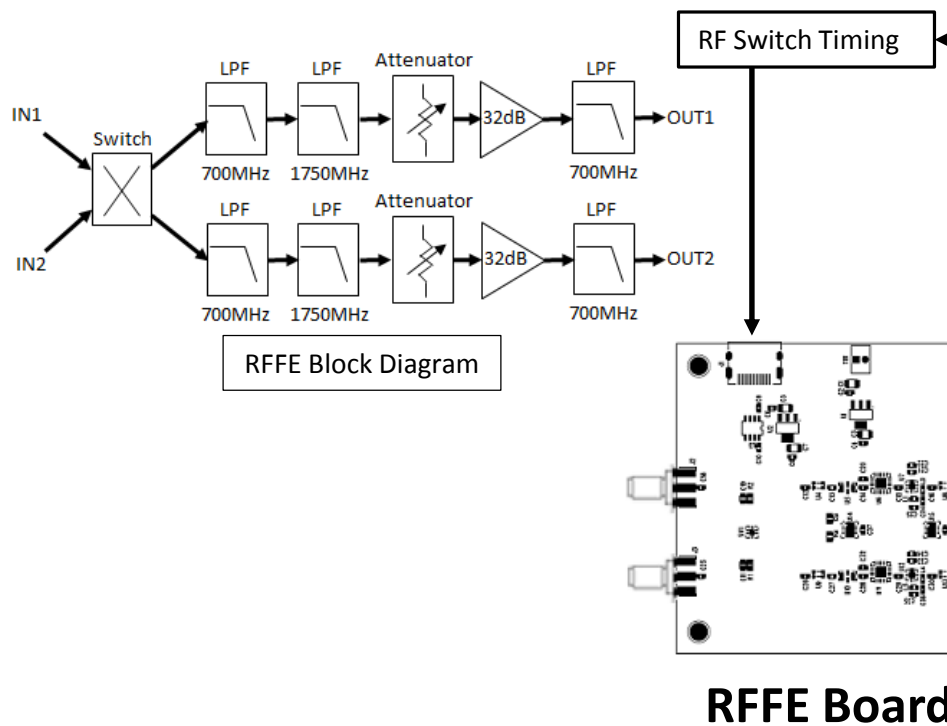

Summary

- Digital Front End (DFE) Improvements
 - RFBPM zDFE board is completed, and fully functional for NSLS-II application
 - Improved performance with new DSP signal processing algorithm
 - Use of Newer Xilinx/Vivado development environment and embedded EPICS IOC
 - Implementation of Embedded Debian Linux operating system for ARM dual core processor
 - Developed a Linux DMA driver for DDR3 memory access (ADC, TBT, FA)
 - Expanded application for the Cell controller, AI system, BbB & BPM system as well as beamline applications

- Analog Front End (AFE) Improvements
 - Improved performance using RF switching
 - Initial test results indicate >5x long term stability improvement
 - Evaluating Peltier cooling option as alternative to temperature controlled rack
 - Future support for Pilot Tone(PT) signal processing for active calibration with better BPF

BPM Development Team

Dan Padrazo (Project Manager)

Weixing Cheng (Physics)

Kim Ha (Embedded Controls, EPICS/IOC, FPGA)

Joe Mead (FPGA, DSP, DFE Board Design)

Tony Caracappa (Embedded Controls, EPICS/IOC, AFE)

Bel Bacha (RF)

Bernard Kosciuk (Mechanical, Thermal Analysis)

Marshall Maggipinto (Technical Support)

Chris Danneil (Technical Support)

John Bohenek (DFE Board Design)

John Kuczewski (Embedded Controls, Linux Kernel)

Acknowledgements

Contributions to this presentation:

Weixing Cheng, Kiman Ha, Joe Mead, Tony Caracappa, Marshall Maggipinto

zDFE Configuration Test:

Weixing Cheng, Kiman Ha, Tony Caracappa, Joe Mead, Marshall Maggipinto, Chris Danneil, Bel Bacha

zBPM Integration Testing:

Weixing Cheng, Kiman Ha, Tony Caracappa, Joe Mead, John Kuczewski, Bel Bacha, Marshall Maggipinto, Chris Danneil

Thank You for Your Attention!

Backup Slides

RF-SW BPM Long-term (10 days)

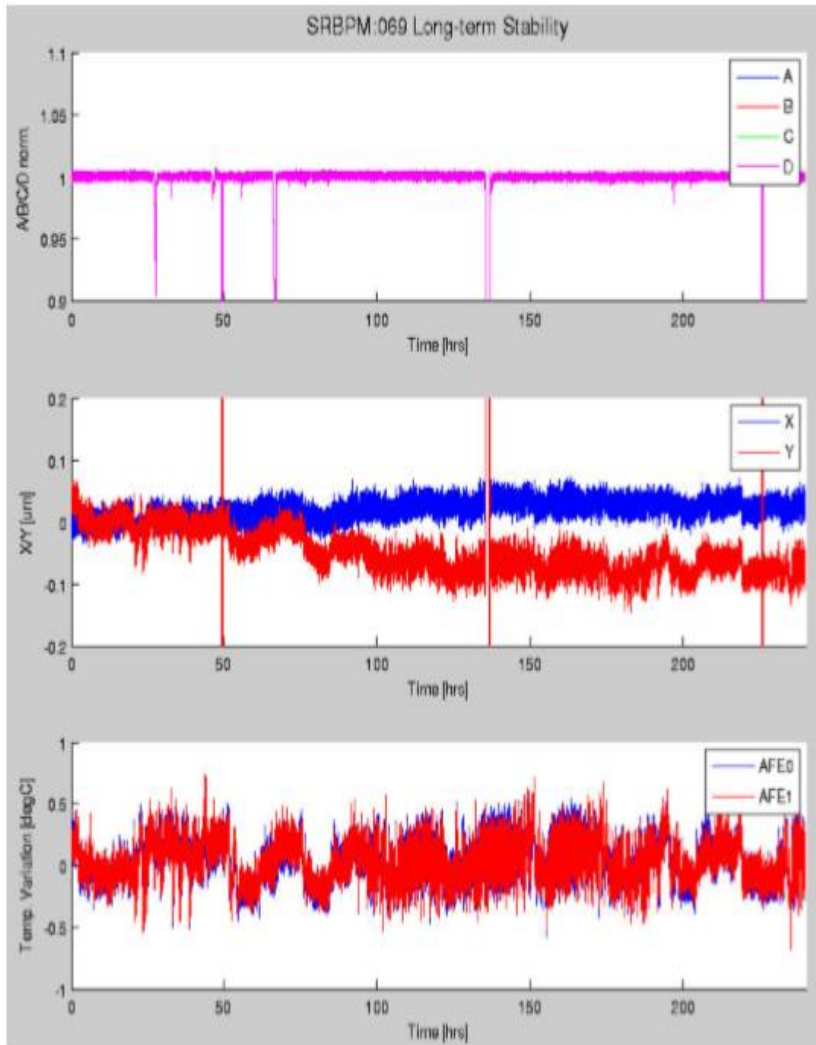

W. Cheng

- 10 days long-term, Non temperature controlled rack
- 400 mA operation
- Gate 1: DDC
 - Std(x) = 0.0146 μm , p2p 0.1192 μm
 - Std(y) = 0.0336 μm , p2p 0.2121 μm
 - Std(AFE0) = 0.0363 deg, p2p 0.3267 deg
- Gate 2: DFT
 - Std(x) = 0.0195 μm , p2p 0.1681 μm
 - Std(y) = 0.0440 μm , p2p 0.2913 μm
 - Std(AFE0) = 0.1741 deg, p2p 1.36 deg

Signal processing block

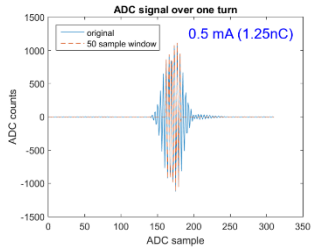
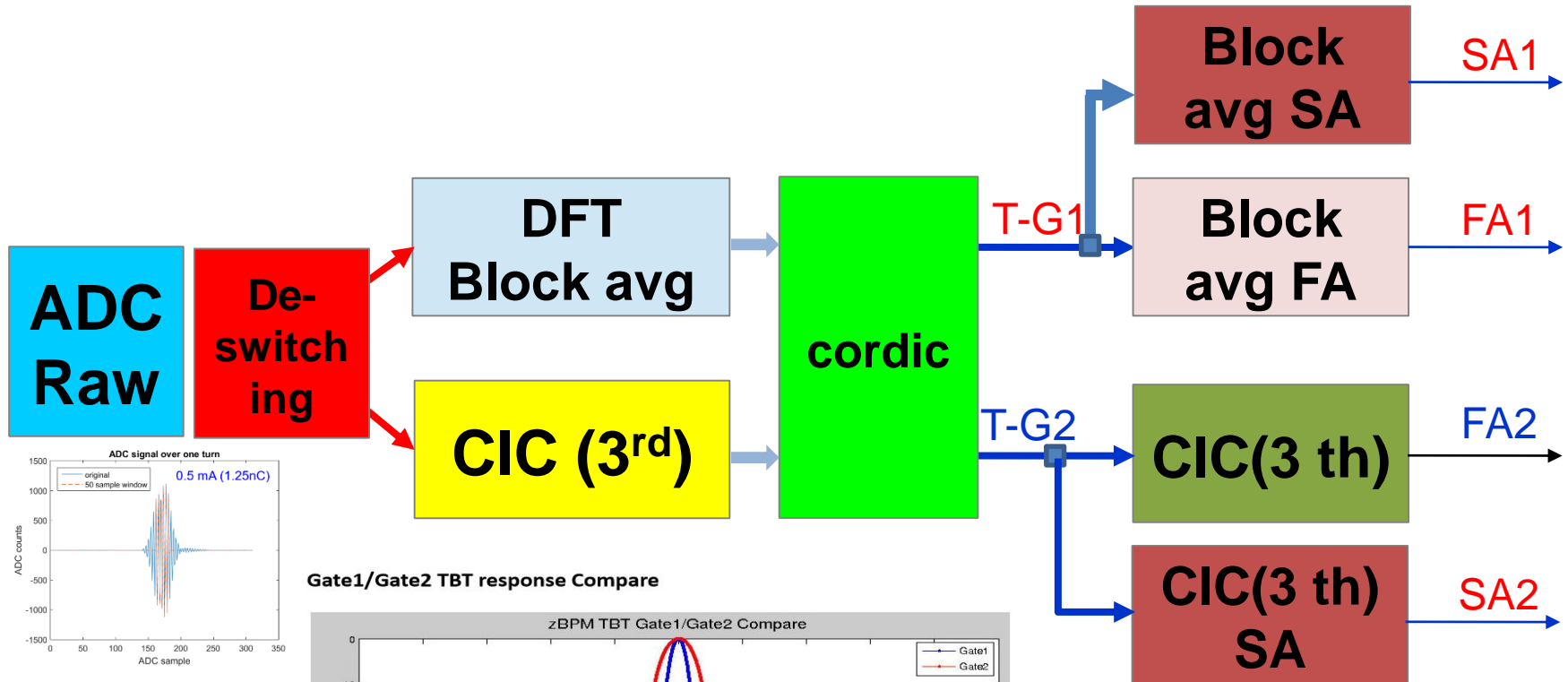

Gate1/Gate2 TBT response Compare

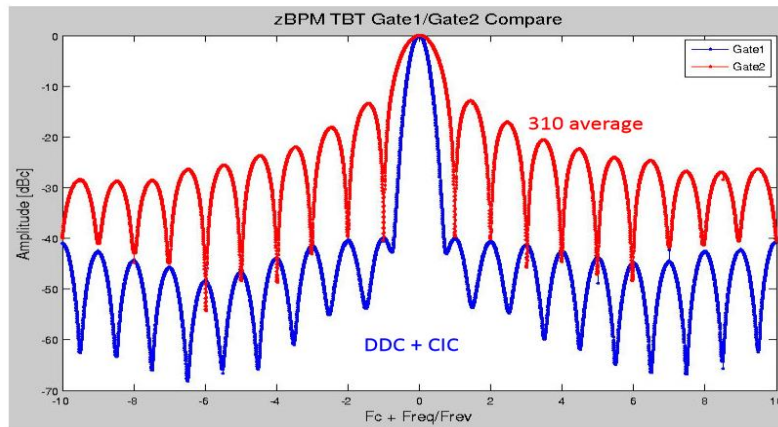

W. Cheng

DFE FPGA Block

- FPGA implemented using a combination of VHDL, Verilog, System Generator (for DSP Block) and EDK for MicroBlaze processor
- 2 main data paths
 - Non Deterministic : ADC, TbT, FA, SA data to DDR memory and then to IOC via Microblaze ProcessorFPGA (Ethernet)
 - Deterministic : FA data to Cell Controller for FOFB and Active Interlock (Fiber Optic)

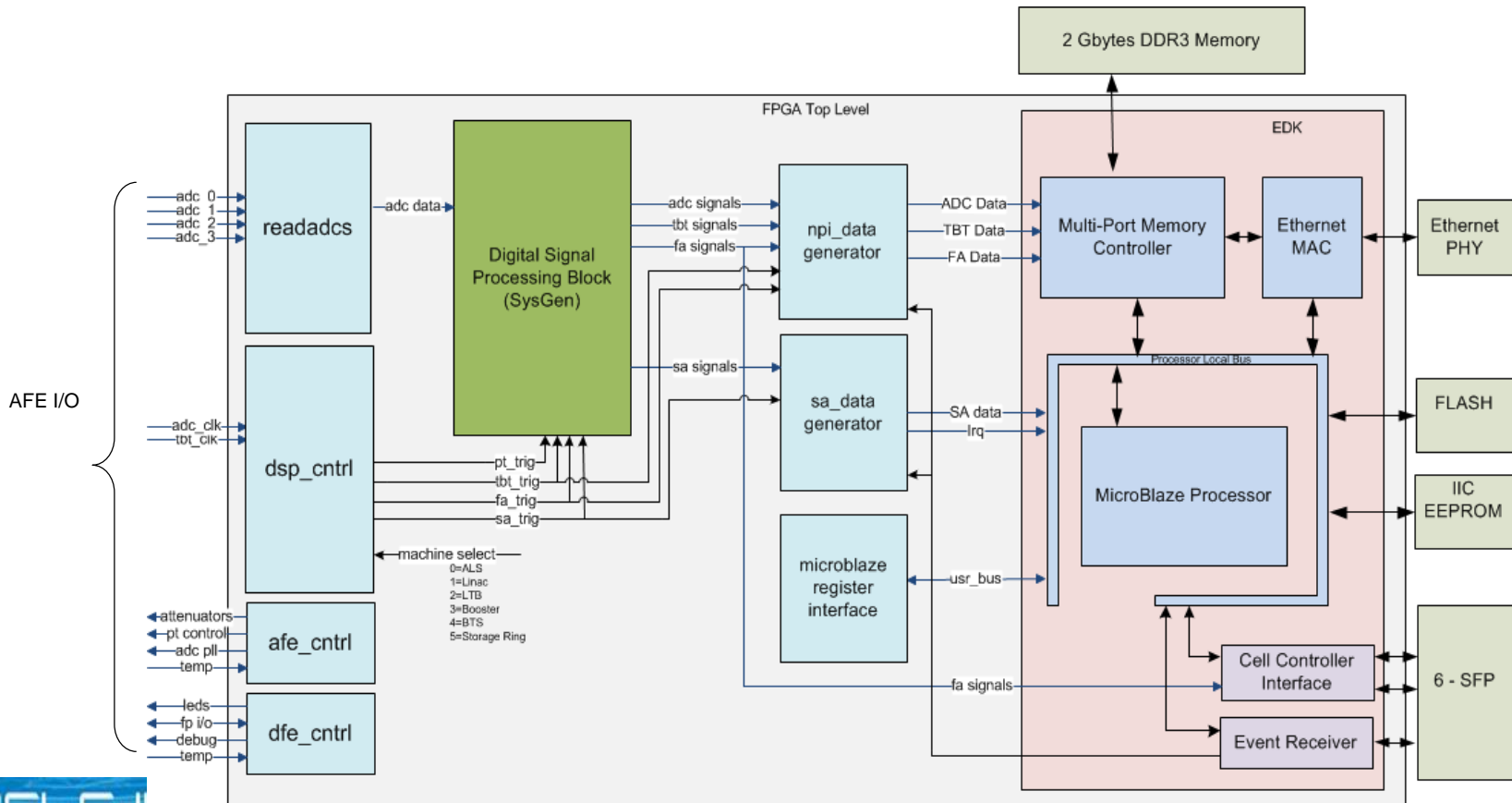

Active Calibration Options, PT

- Initial concept, use custom diplexer developed by K&L Microwave for injection and combining of Out-of-Band Pilot-Tone
 - Alternate In-Band Pilot-Tone calibration using integrated microwave Stripline coupler assembly in place of Diplexer assembly.
- Temperature dependent band pass response of existing SAW filters on RFBPM AFE, prevented successful implementation.

NSLS-II AFE SAW BPF has large gain variation within passband, and it's sensitive to temperature variation.

Pilot tone and beam signals see different in position changes, while temperature varies.

Ceramic BPF helps a lot (ALS) allows pilot tone calibration.

Pilot tone (@ $-4.5 \cdot F_{rev}$) and beam see different position drifts. Positions calculated from $g_a/g_b/g_c/g_d$.

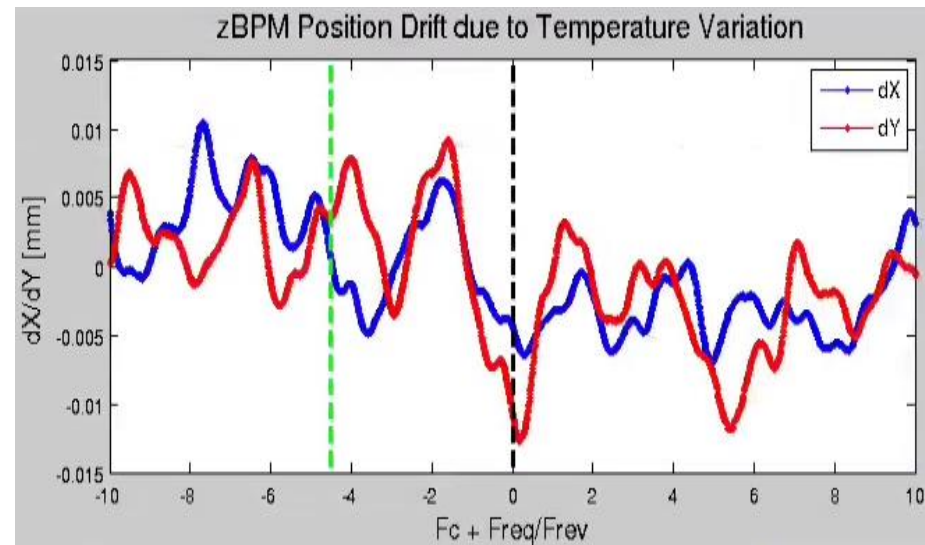
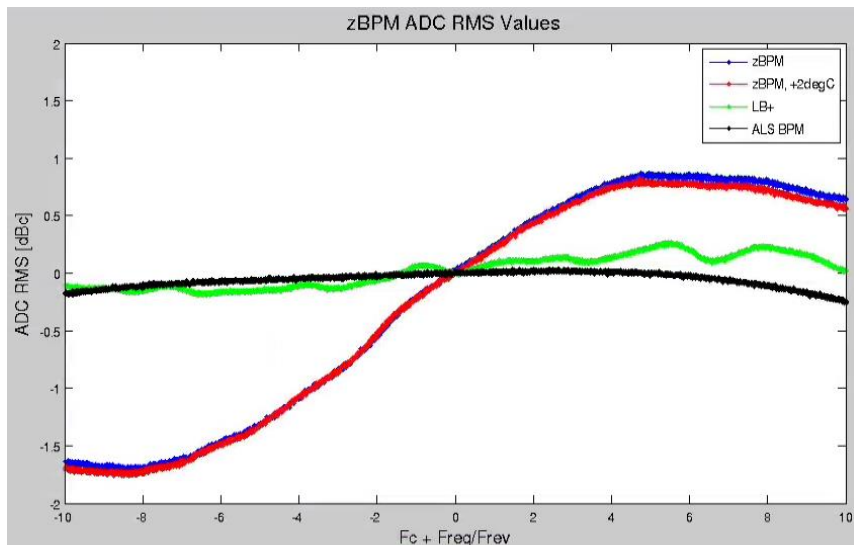

zDFE FPGA Block

- FPGA implemented using a combination of VHDL, Verilog, System Generator (for DSP Block)
- 2 main data paths
 - Non Deterministic : ADC, TbT, FA, SA data to DDR memory and then to IOC via ARM A9 Processor/FPGA (Ethernet)
 - Deterministic : FA data to Cell Controller for FOFB and Active Interlock (Fiber Optic)

