



Bare RFD Drawing and Couplers Design Update

Giovanni Casula - Fermilab
Zenghai Li - SLAC



Updated RFD drawing

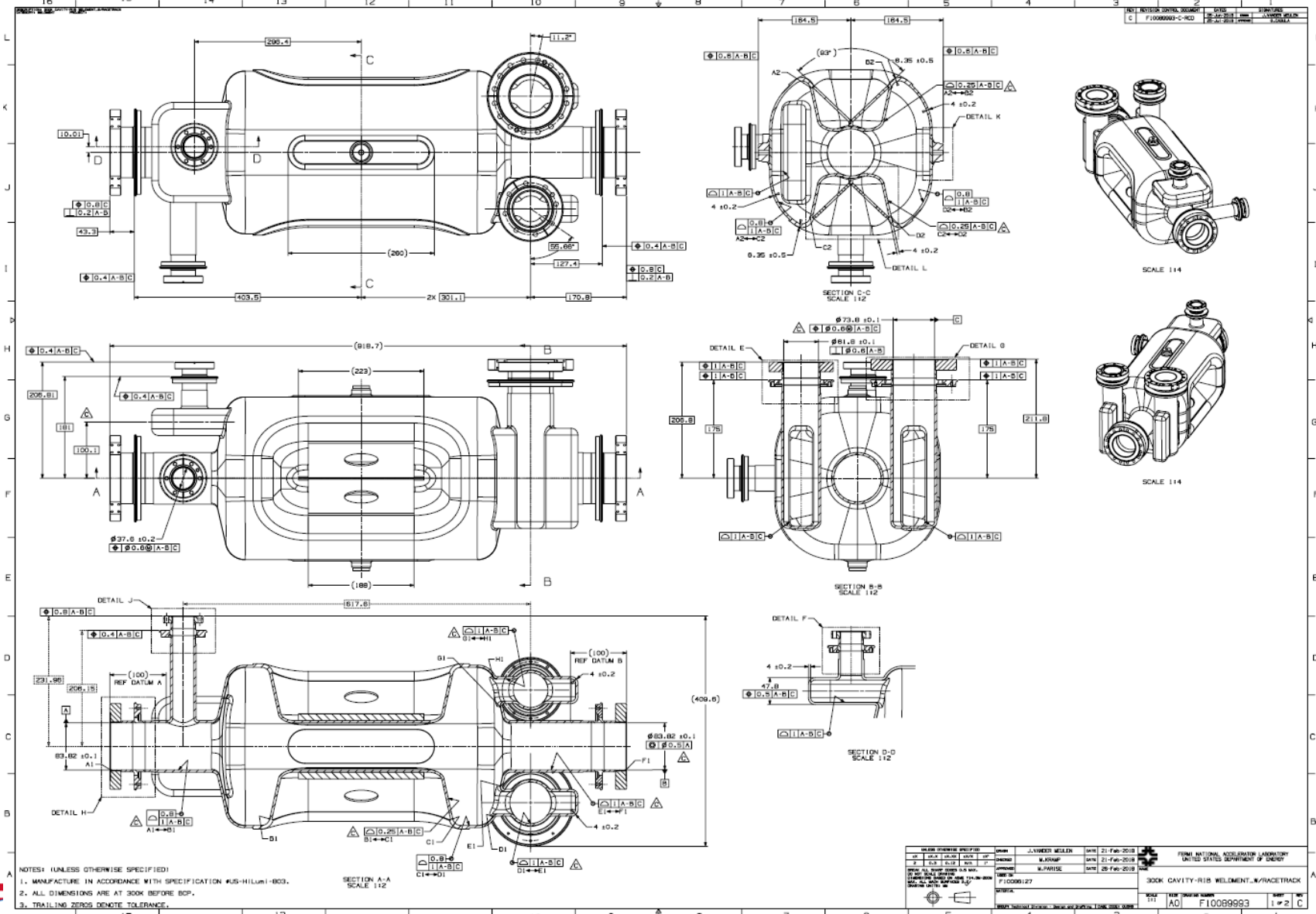

Updated RFD drawing – Tolerances

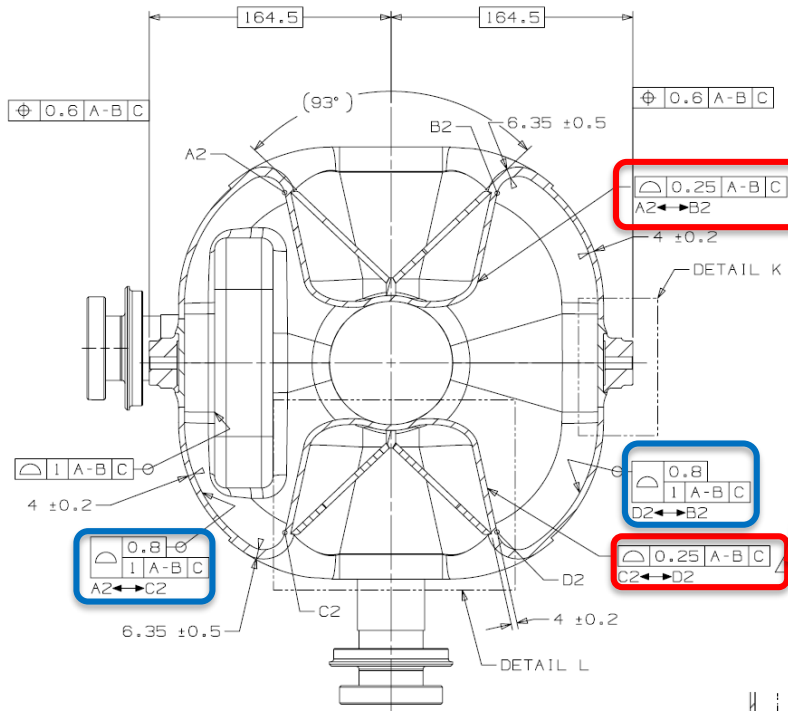

NOTE: these poles' tolerances have to be transposed in the fabrication drawings of the poles, their final value in relation to datum A,B,C are bigger because affected also by the external profile tolerance

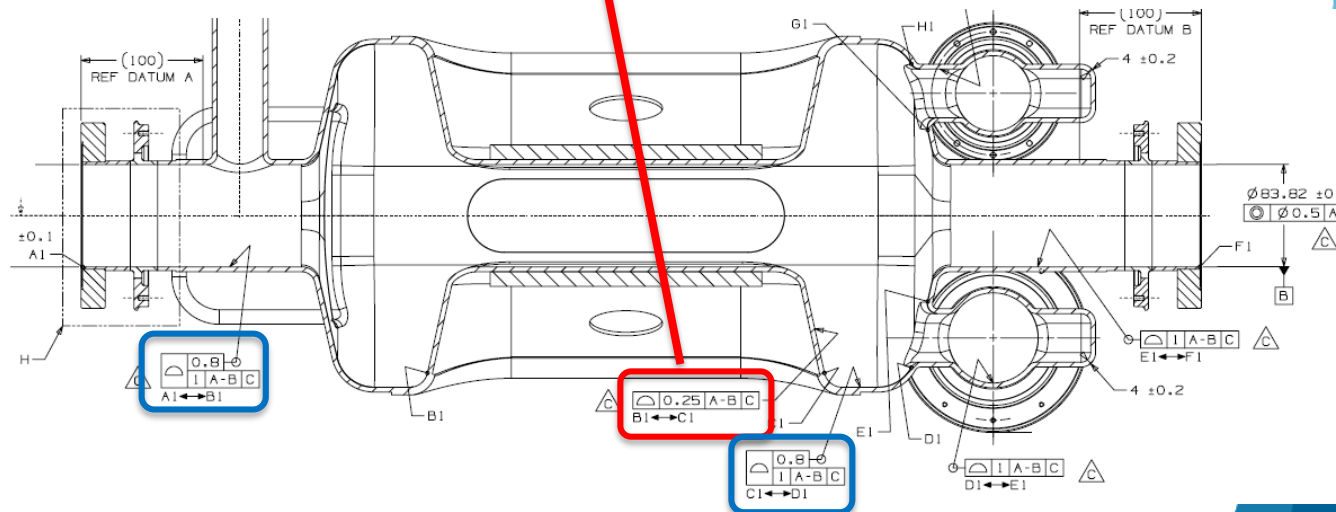
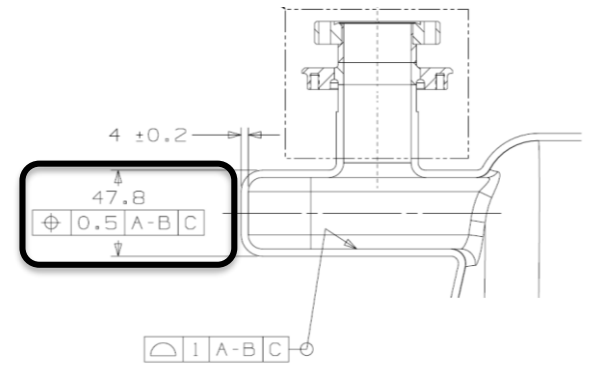

Couplers Updated Mechanical Design

- LARP mechanical design has been updated with input from Zenghai's RF design
- Possible modifications needed for the feedthroughs

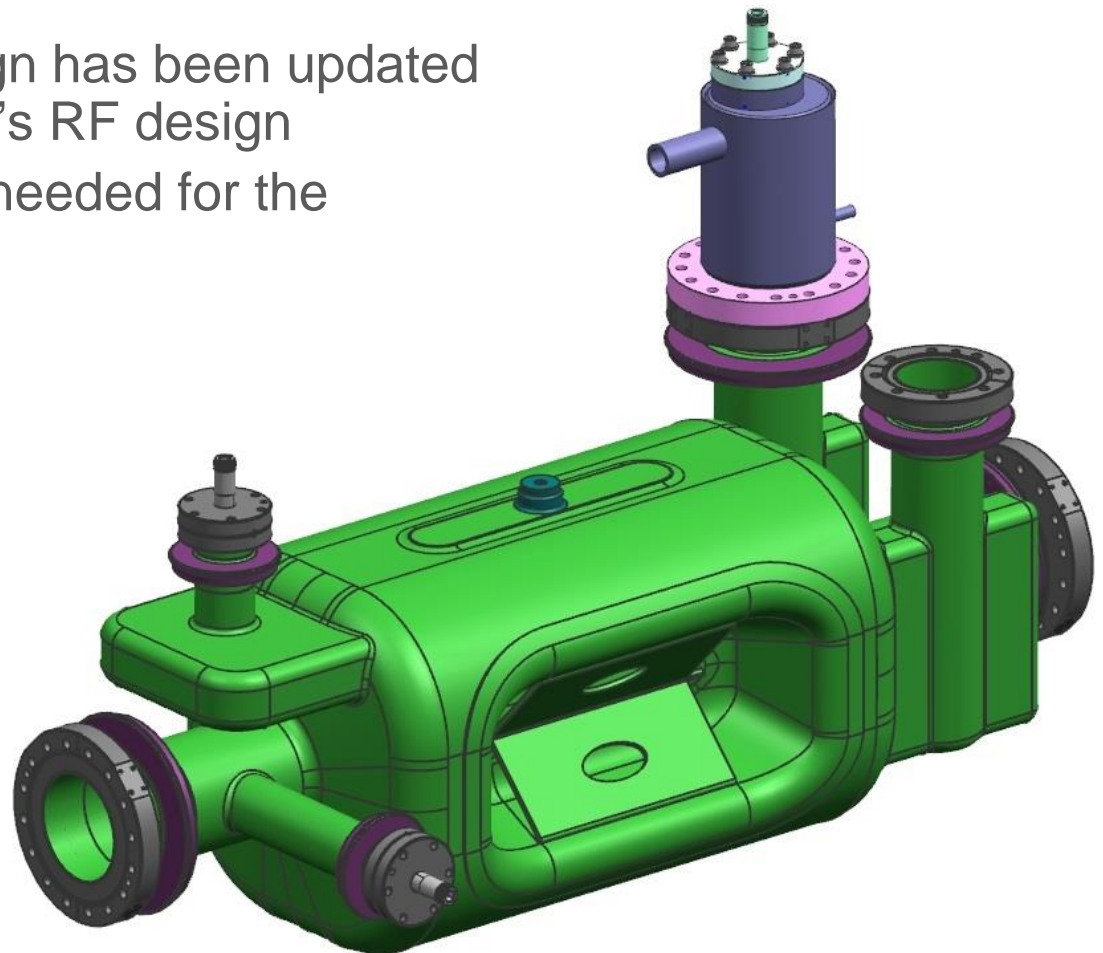

HHOM Coupler Mechanical Design

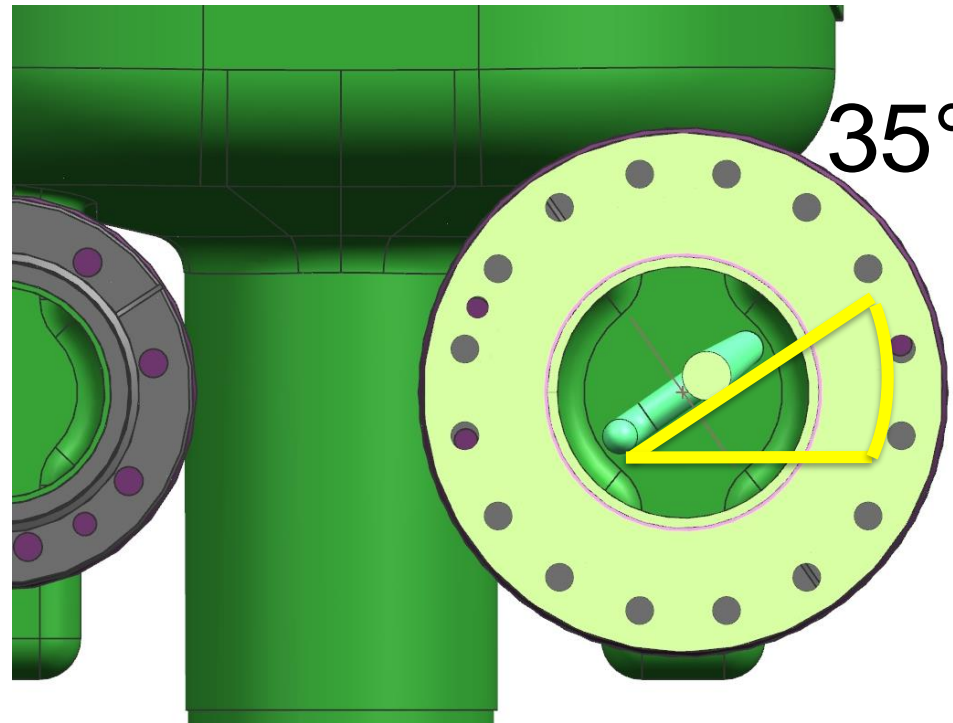
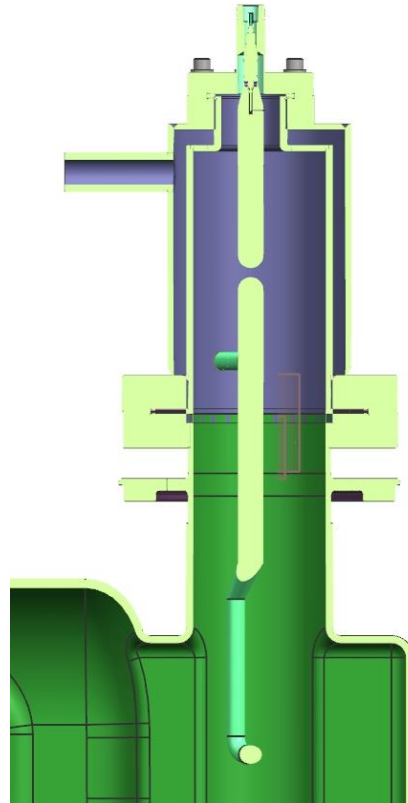
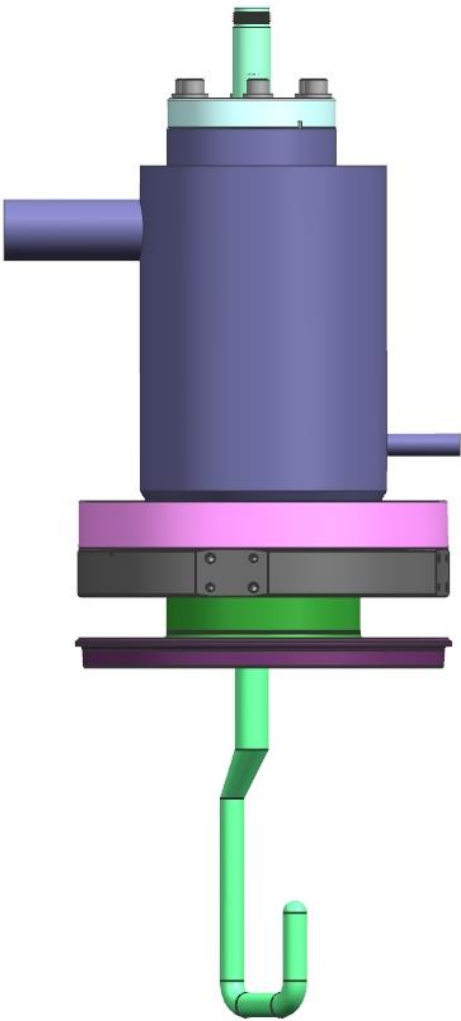

VHOM Coupler Mechanical Design

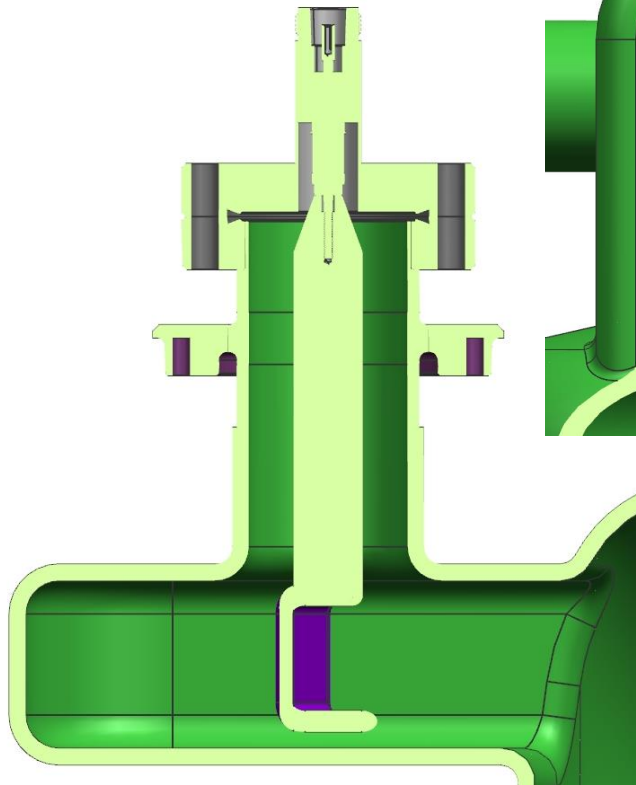
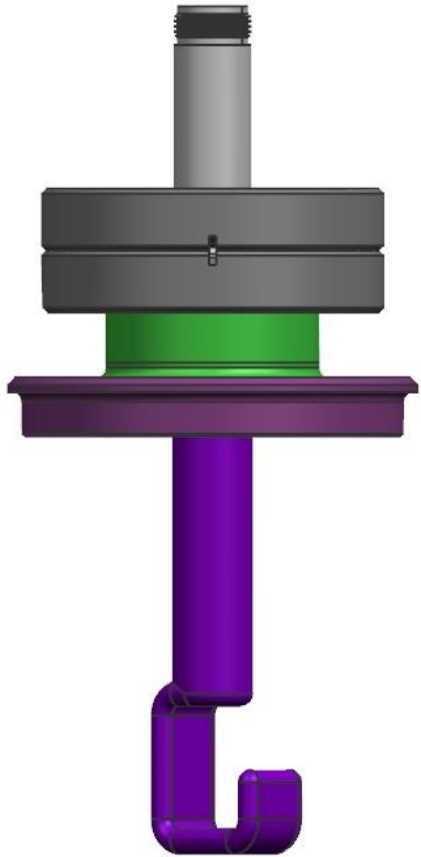

Pick-Up Antenna Mechanical Design

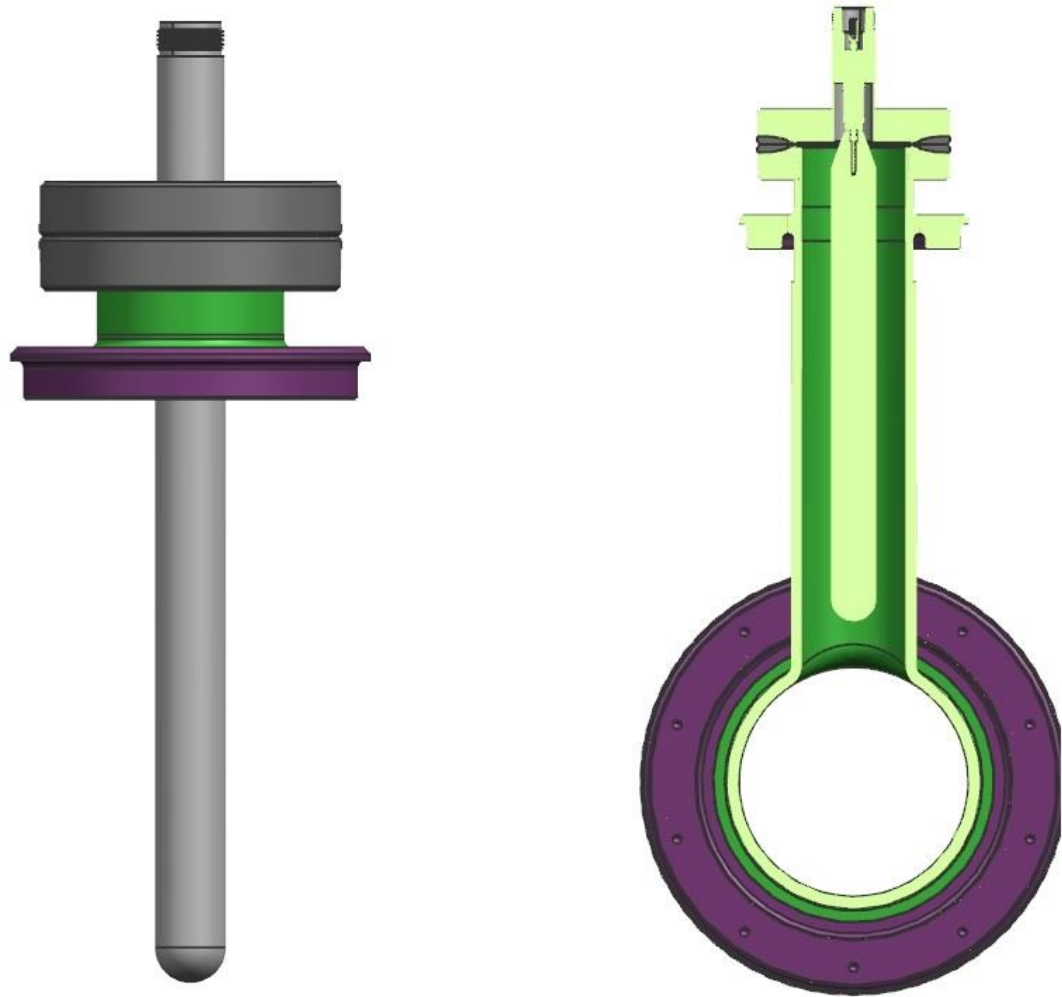

DQW coax window - CERN design



Interface dimensions

(in mm)	DQW	RFD H-HOM	RFD V-HOM
HOM end: r1	8.42	8.7	8.70
HOM end: r2	17.06	20.00	20.00
Coaxial line: r1		7.00	
Coaxial line: r2		20.07	

V-HOM Window

- 10-mm ceramics

