



HL-LHC Integration Meeting n107

Layout Drawings for IP2 and IP7:

- LSSL2/LSSR2
- LSSL7/LSSR7

João Oliveira

WP15: Integration & (De-) Installation

Introduction

The aim of this meeting:

- Show the status of the Layout for:
 - LHCLSXH_0003 (**LSSL2**)
 - LHCLSXH_0004 (**LSSR2**)
 - LHCLSXH_0013 (**LSSL7**)
 - LHCLSXH_0014 (**LSSR7**)

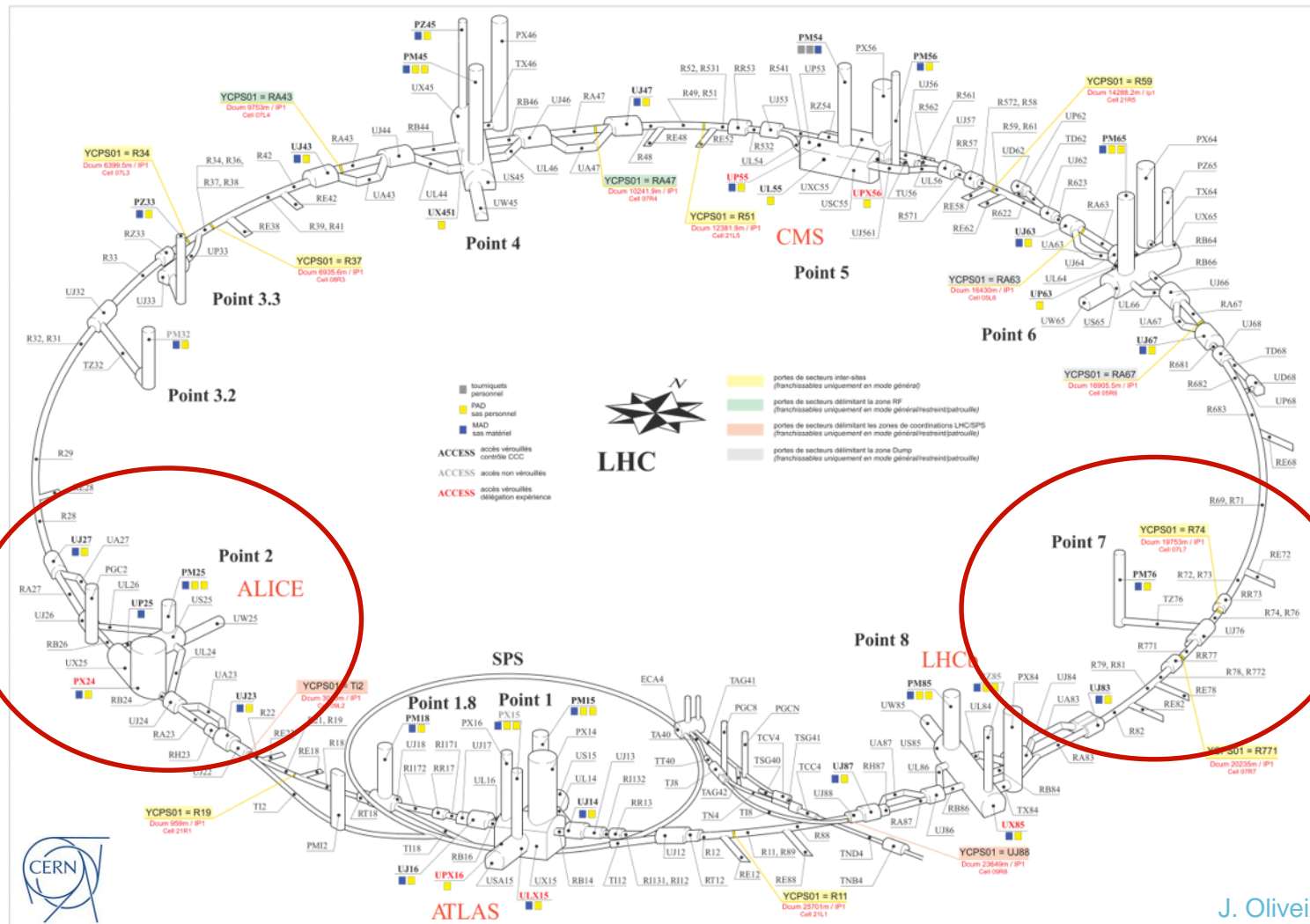

Red Beam and Blue Beam

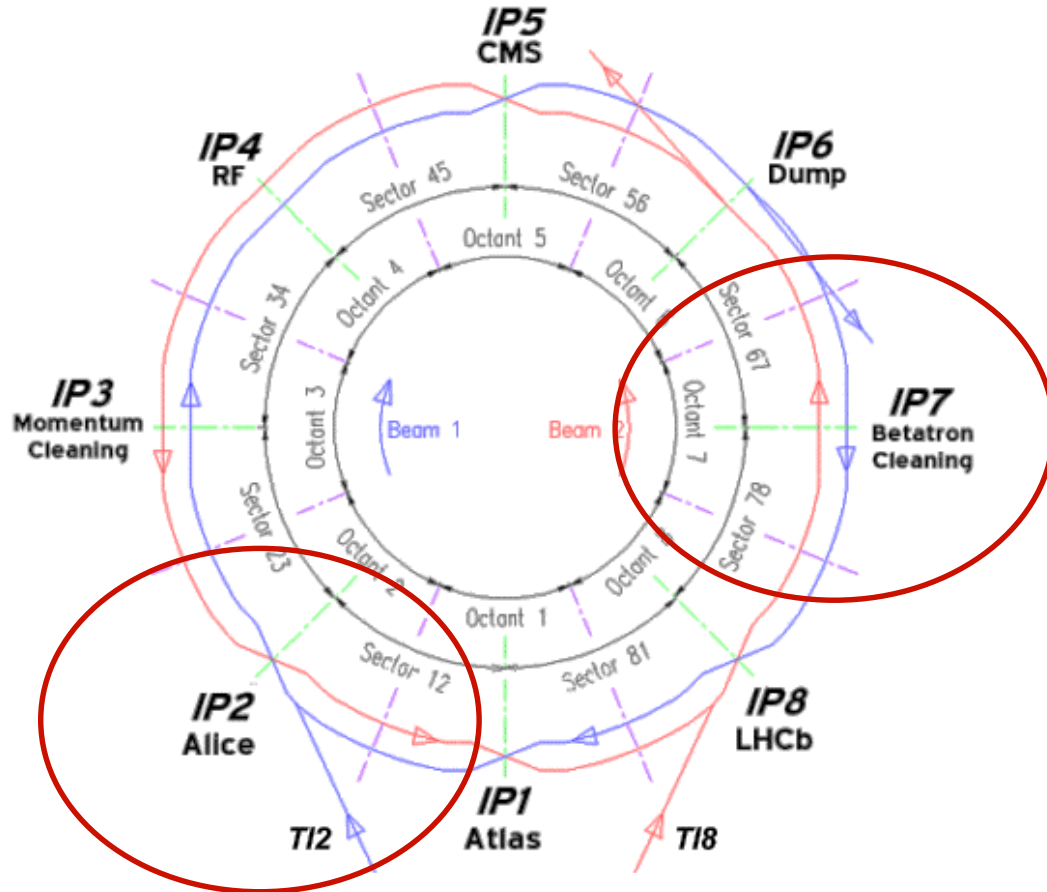

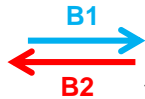

LSSL2

HL-LHC

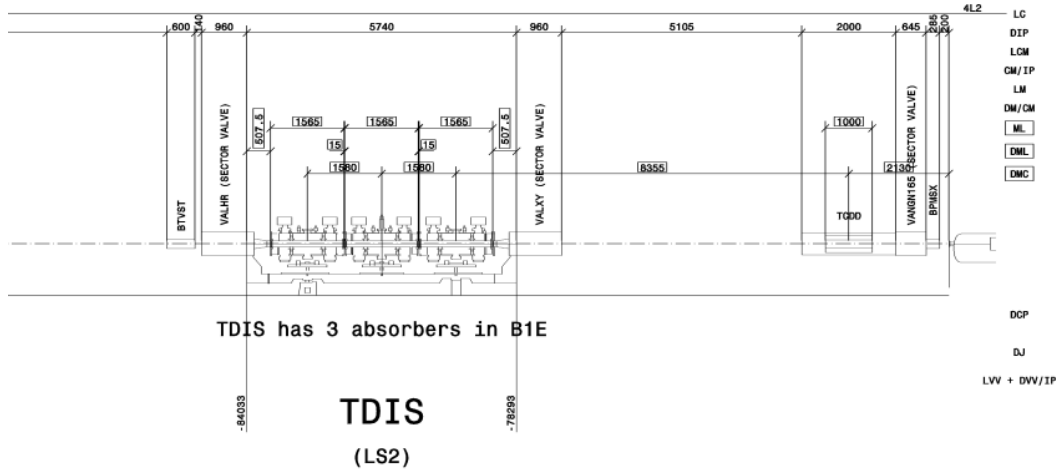

LHCLSXH_0003

LHCLSX_0003

LHC

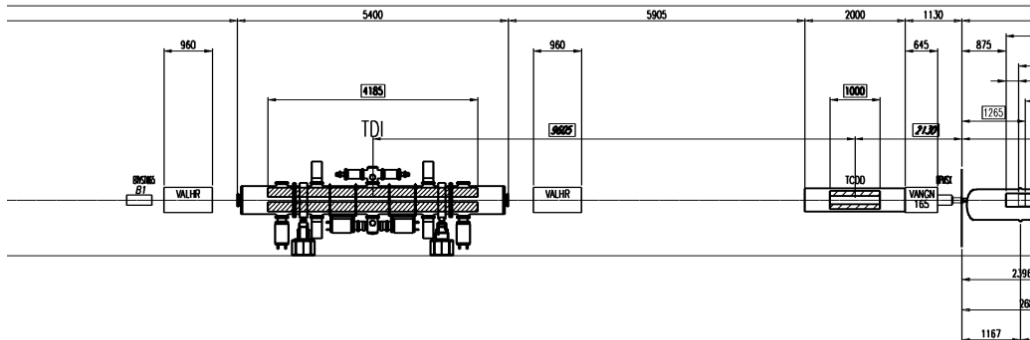

TDIS ECR EDMS 1936580

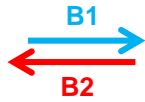

LSSL2

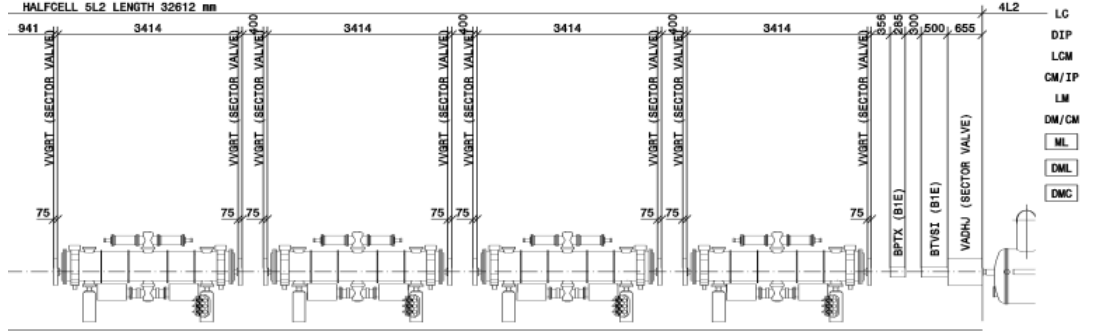

4 MKI kickers acting on B1E injection

MKI MKI MKI MKI

LHCLSXH_0003

LHCLSX_0003

LHC

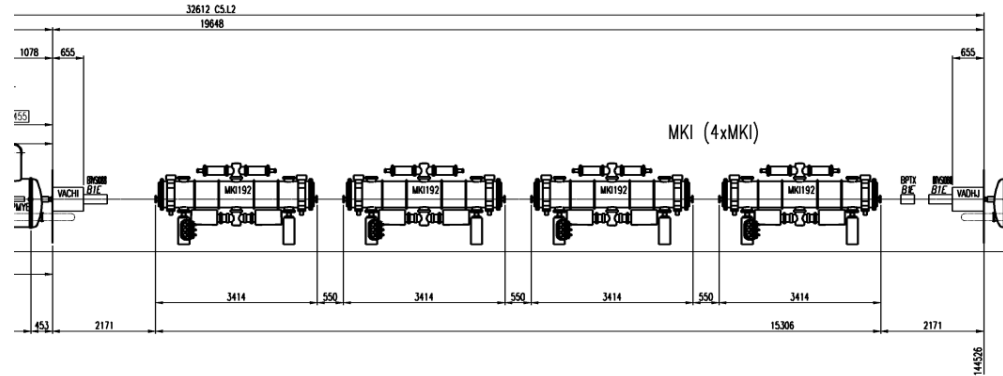

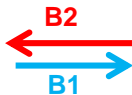

LSSR2

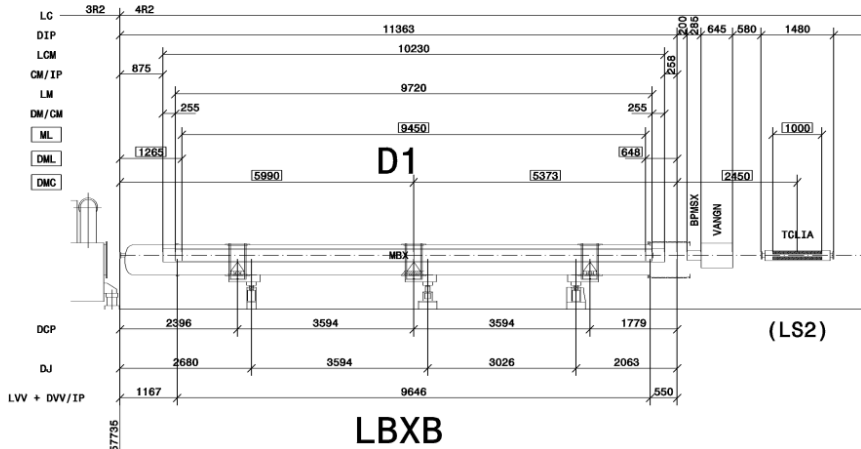

LHCLSXH_0004

HL-LHC

LHCLSX_0004

LHC

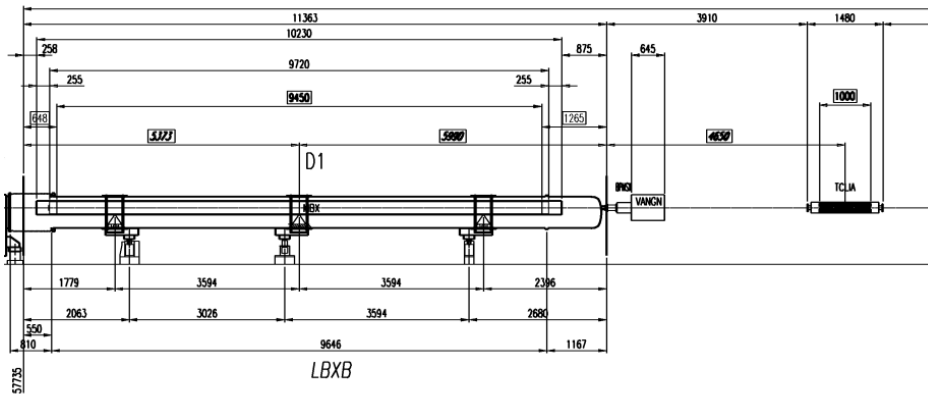

TCLIA ECR EDMS 1936597

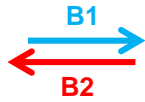

LSSL7

HL-LHC

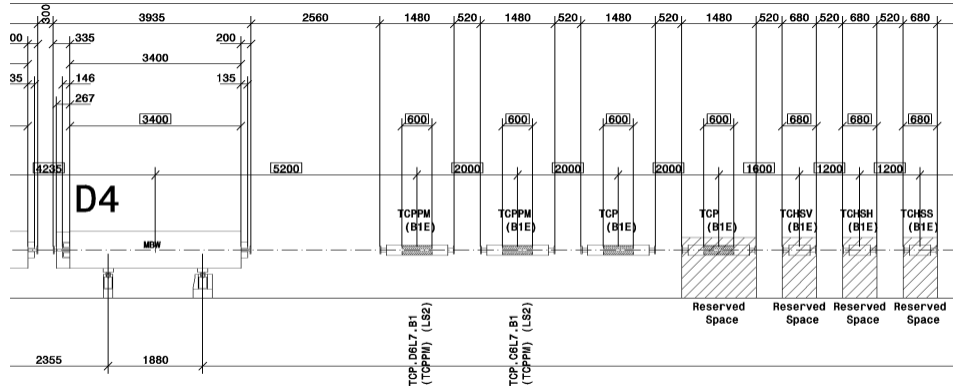

LHCLSXH_0013

LHC

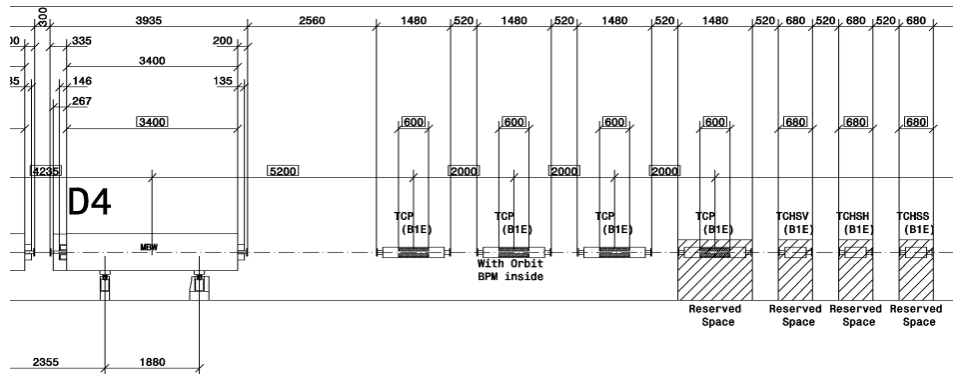

LHCLSX__0013

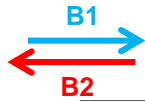

LSSL7

HL-LHC

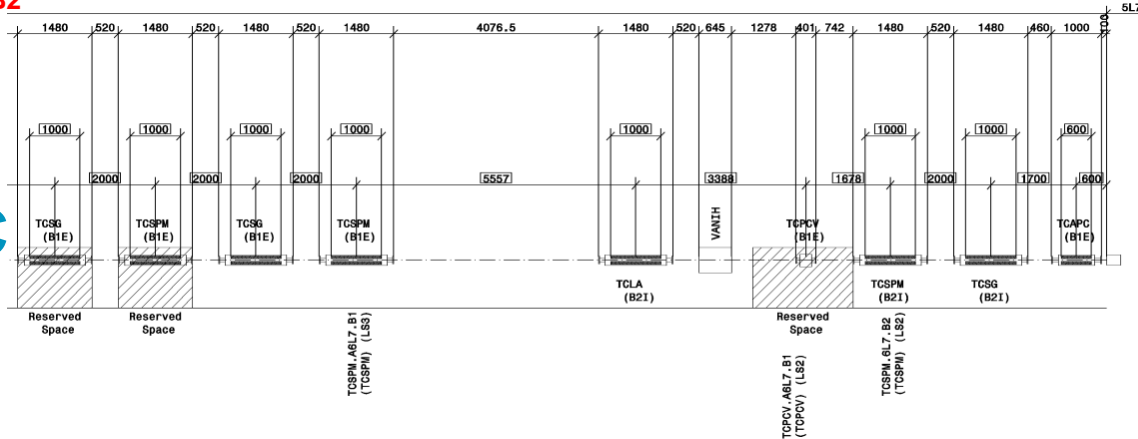

LHCLSXH_0013

- LC
- DIP
- LCM
- CM/IP
- LM
- DM/CM
- ML
- DML
- DMC

LHC

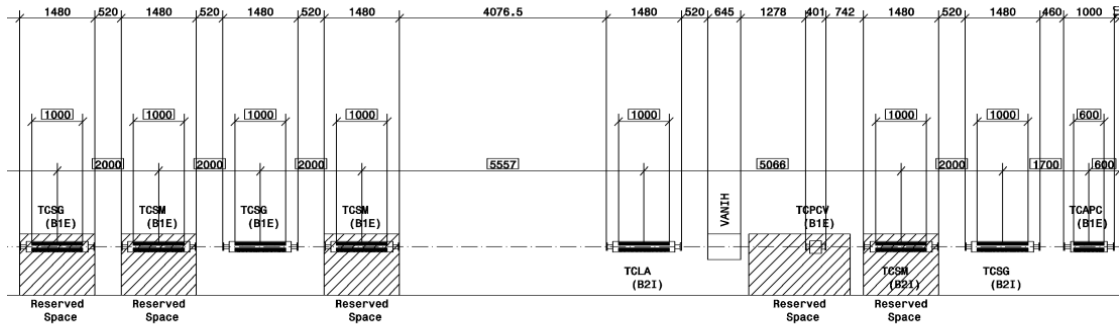

LHCLSX__0013

- DCP
- DJ
- LVV + DVV/IP

- DIP
- LCM
- CM/IP
- LM
- DM/CM
- ML
- DML
- DMC

TCPC (Crystal) ECR EDMS 1839549

TCSPM (LS2) ECR EDMS 1973031

- DVVJ
- DVV/IP
- LW
- ..



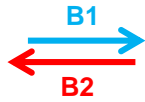

LSSL7

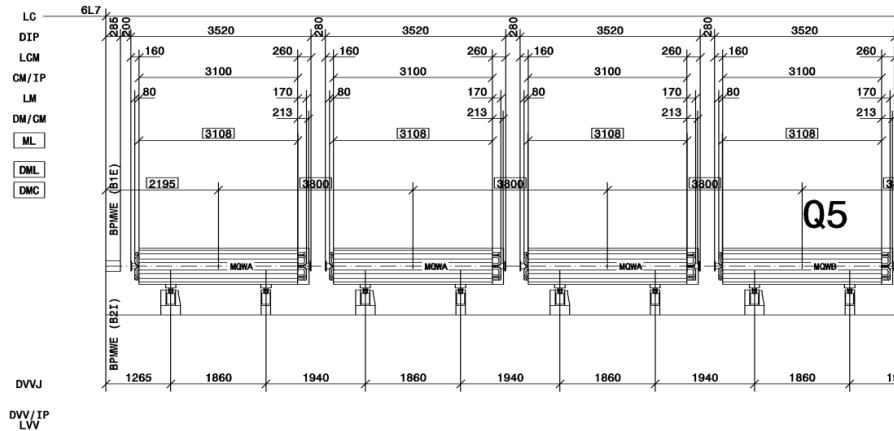
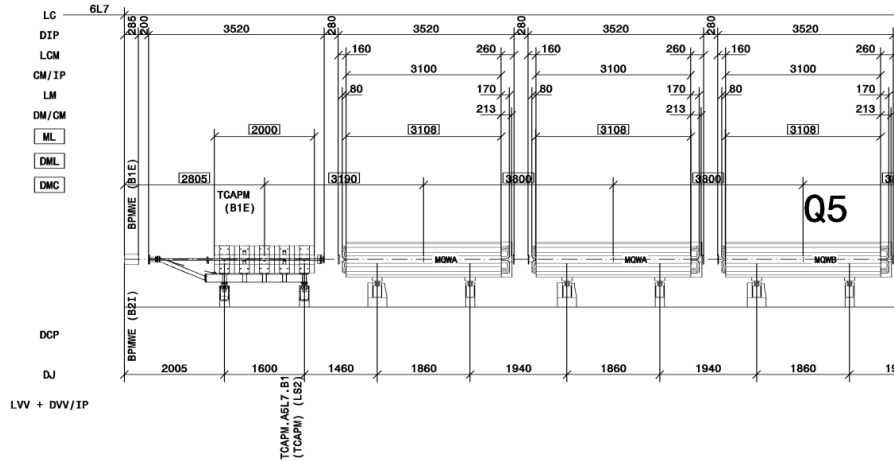

LHCLSXH_0013

LHCLSX__0013

HL-LHC

LHC

TCAPM ECR EDMS 1973905

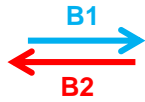

LSSL7

HL-LHC

LHCLSXH_0013

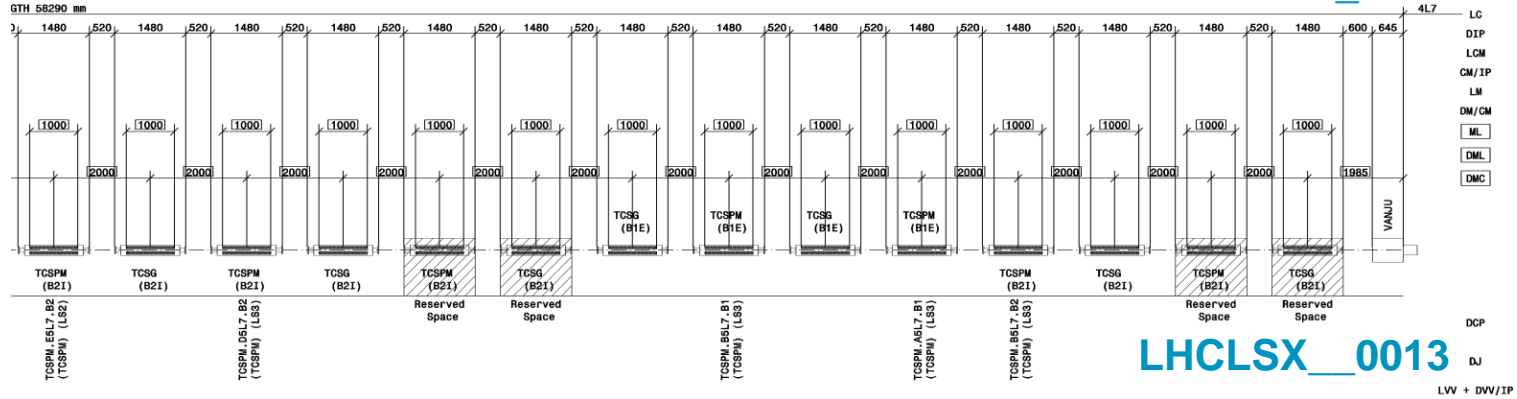

LHC

LHCLSX_0013

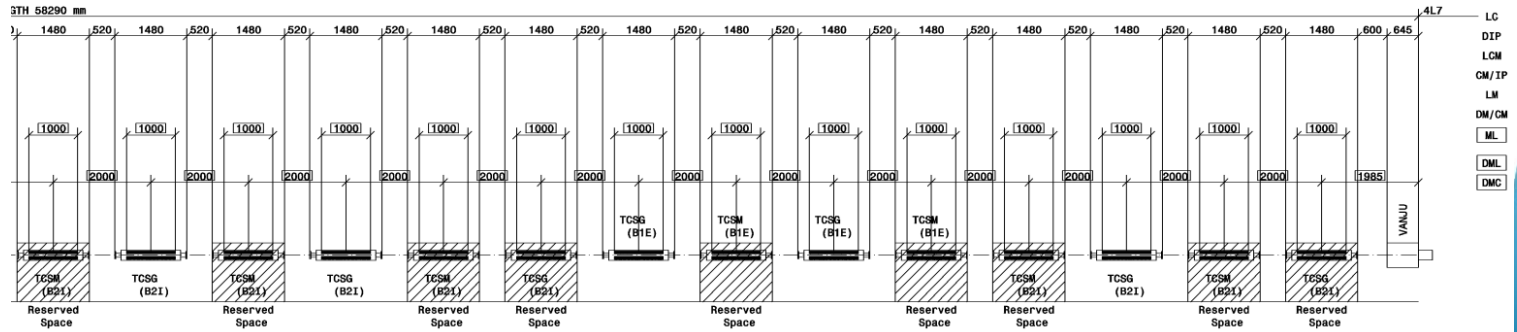

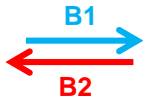

LSSL7

HL-LHC

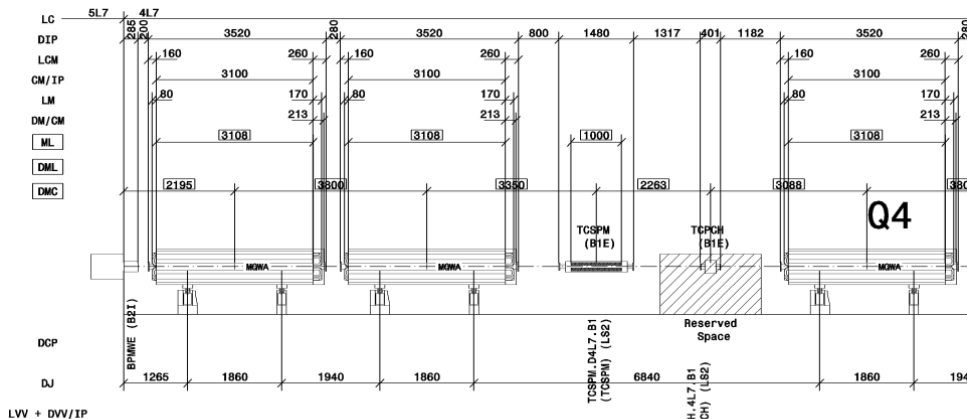

LHCLSXH_0013

LHC

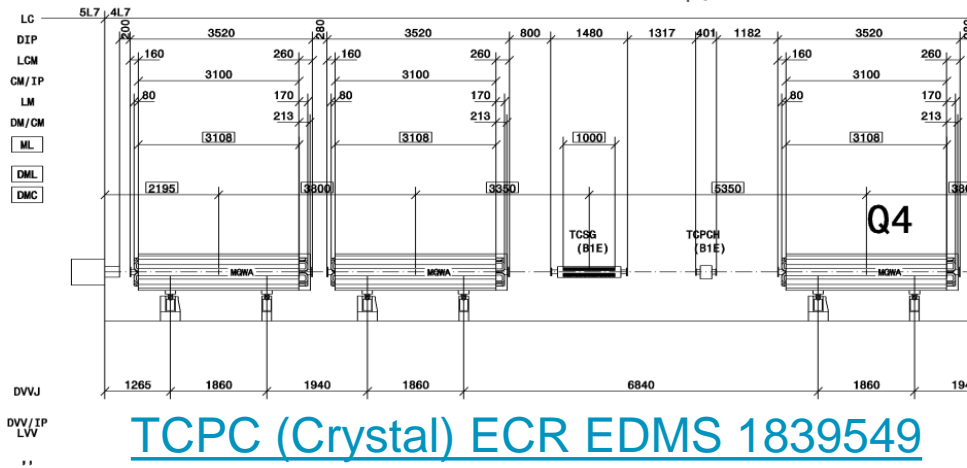

LHCLSX_0013

[TCPC \(Crystal\) ECR EDMS 1839549](#)
[TCSPM \(LS2\) ECR EDMS 1973031](#)

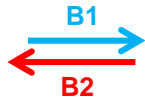

LSSL7

HL-LHC

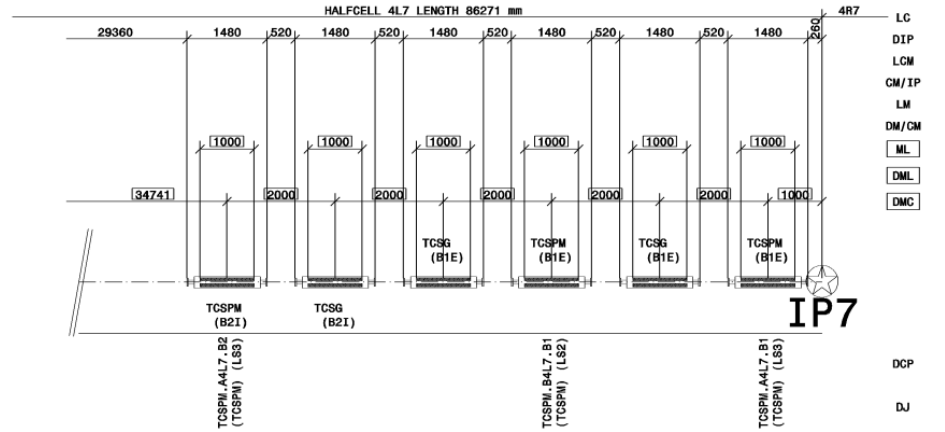

LHCLSXH_0013

LHC

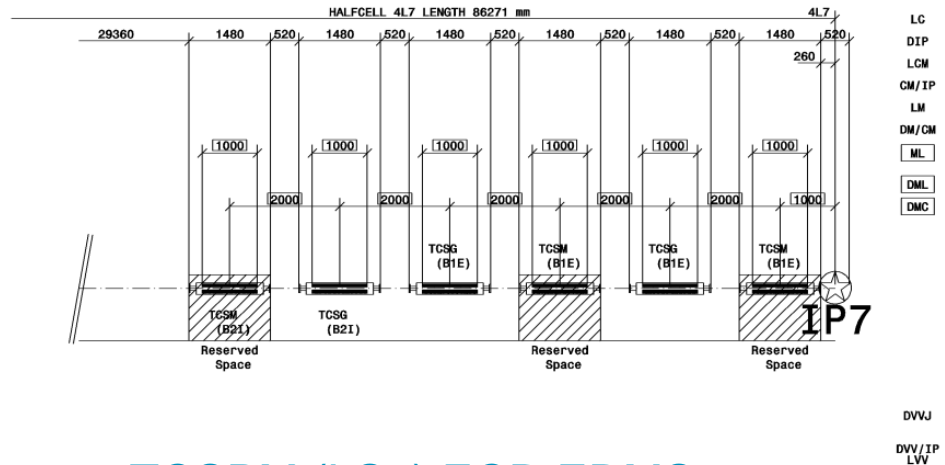

LHCLSX__0013



TCSPM (LS2) ECR EDMS 1973031

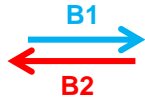

LSSR7

HL-LHC

LHC

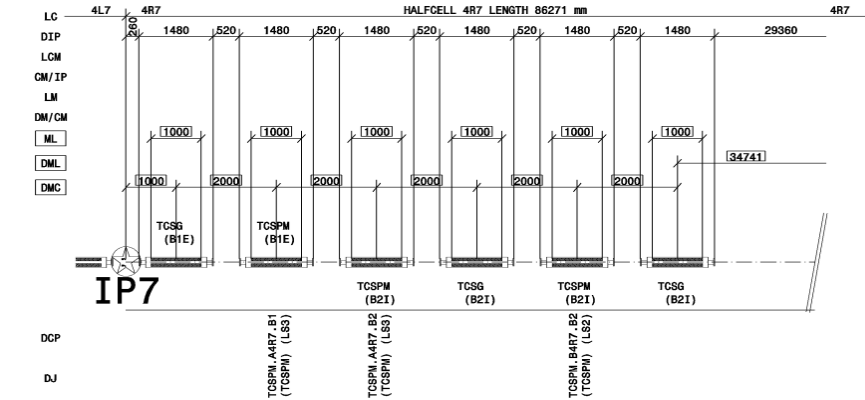

LHCLSXH_0014

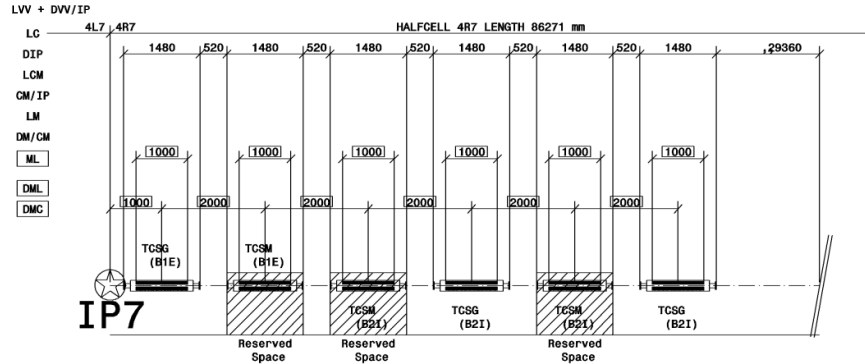

LHCLSX__0014

DVUJ
DVV/JP
LW
..

TCSPM (LS2) ECR EDMS 1973031

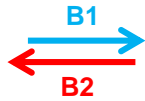

LSSR7

HL-LHC

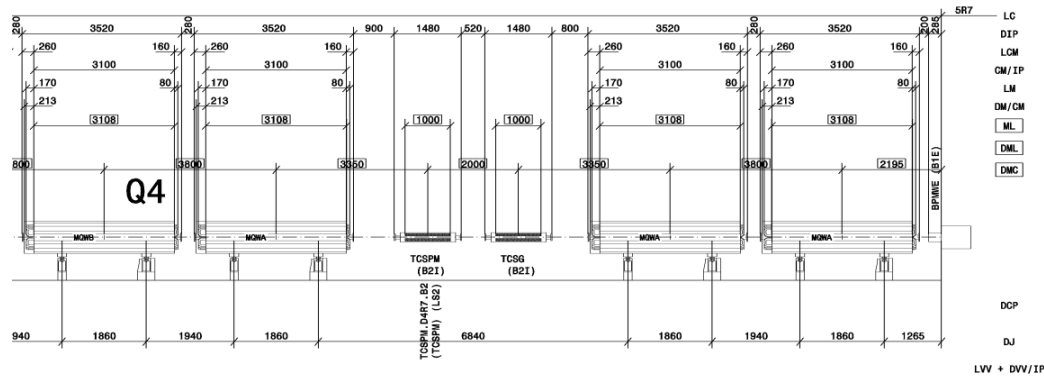

LHC

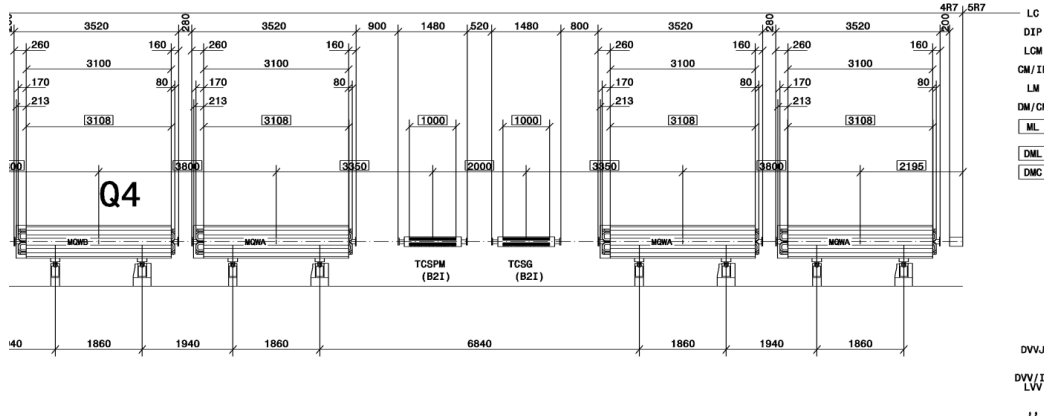

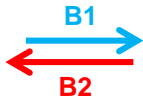

LSSR7

LHCLSXH_0014

HL-LHC

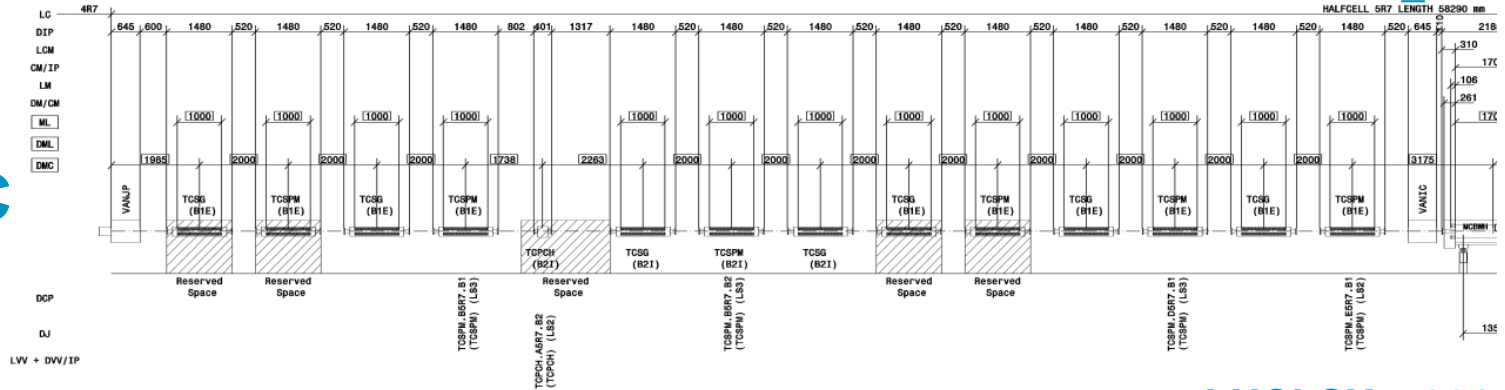

LHCLSX_0014

LHC

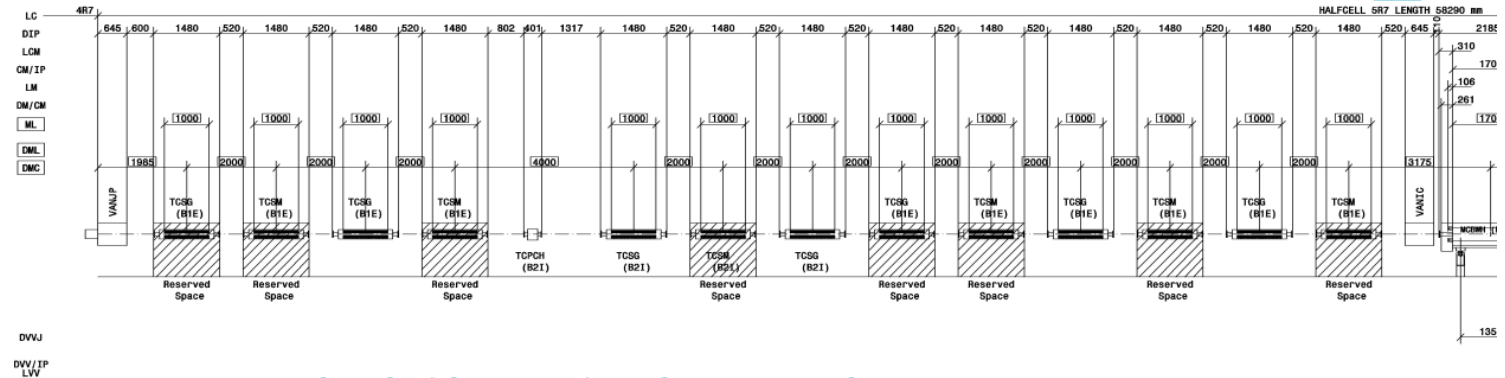

[TCPC \(Crystal\) ECR EDMS 1839549](#)
[TCSPM \(LS2\) ECR EDMS 1973031](#)

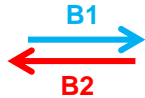

LSSR7

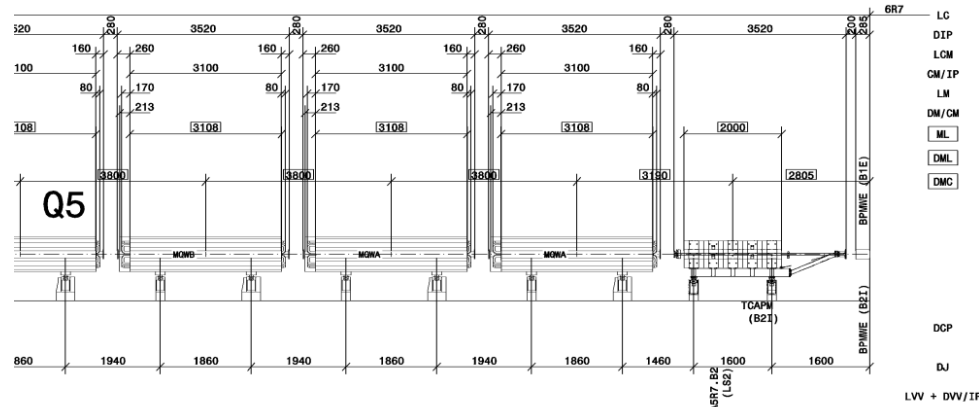

LHCLSXH_0014

HL-LHC

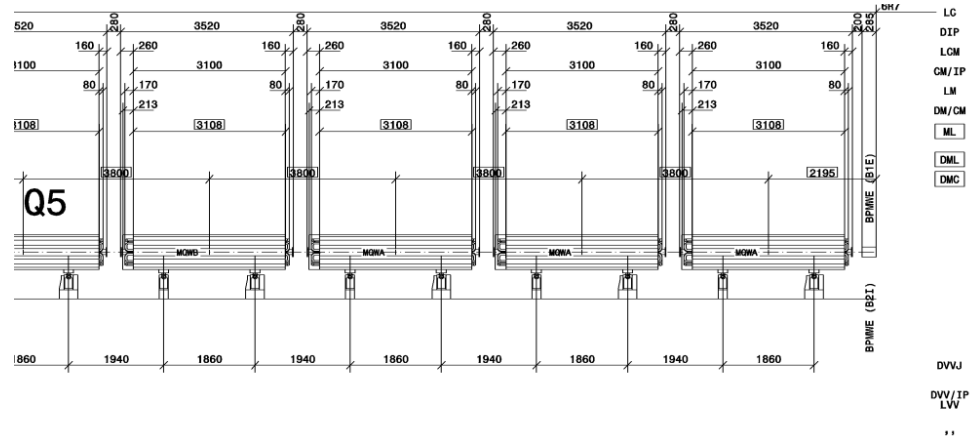

LHCLSX__0014

LHC



TCAPM ECR EDMS 1973905

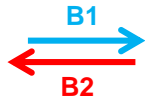

LSSR7

LHCLSXH_0014

HL-LHC

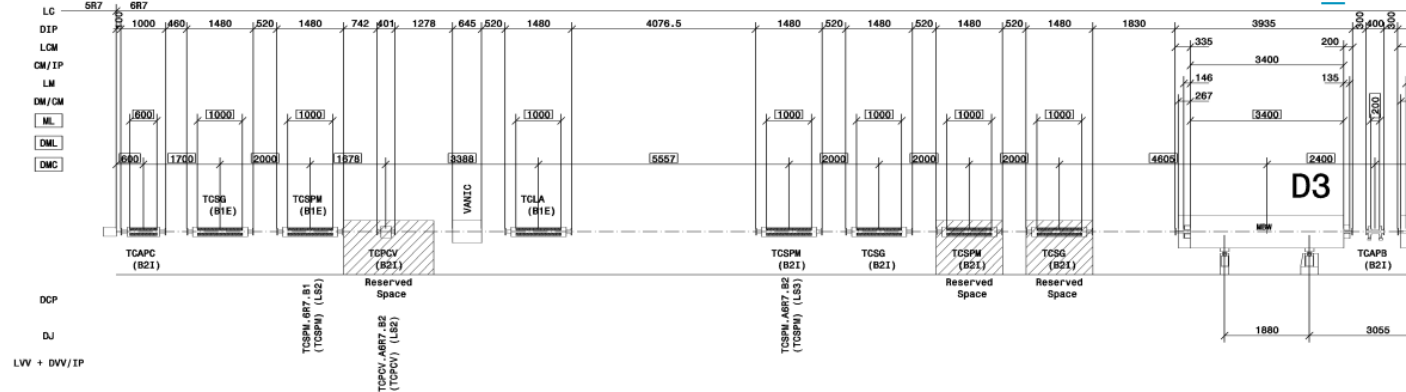

Only installed equipment (not reserved spaces) appears on this table.

LHCLSX_0014

LHC

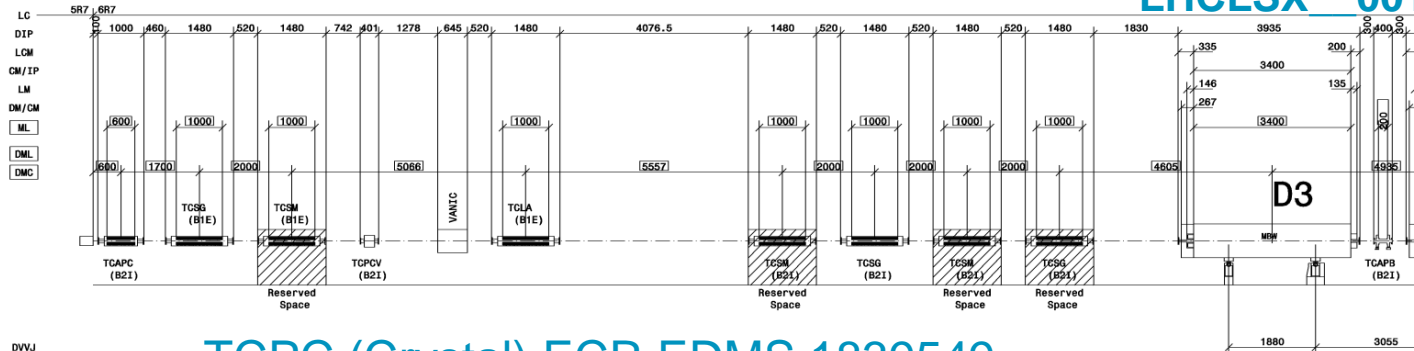

[TCPC \(Crystal\) ECR EDMS 1839549](#)

[TCSPM \(LS2\) ECR EDMS 1973031](#)

DVVJ
 DVV/IP
 LVV
 ..

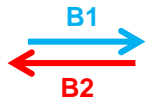

LSSR7

LHCLSXH_0014

HL-LHC

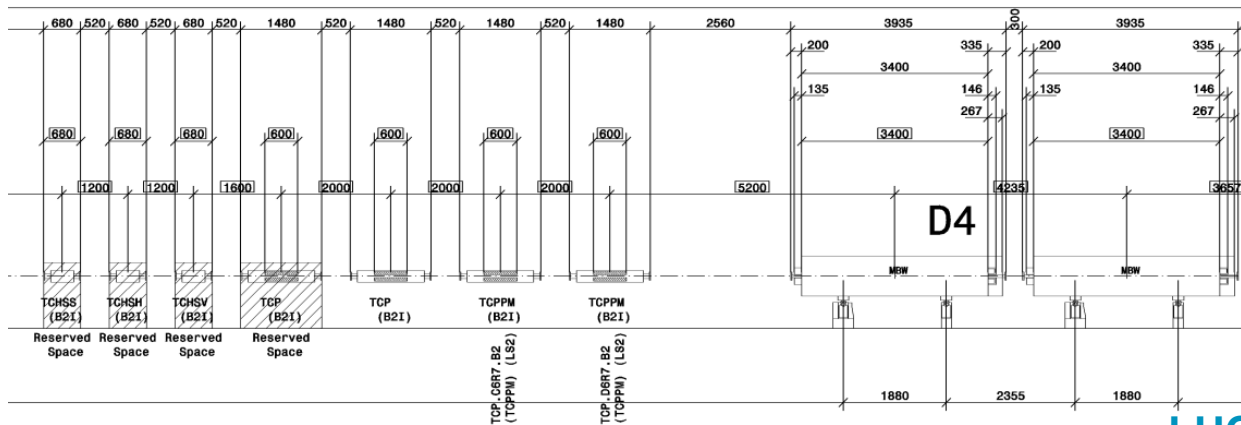

LHC

LHCLSX_0014

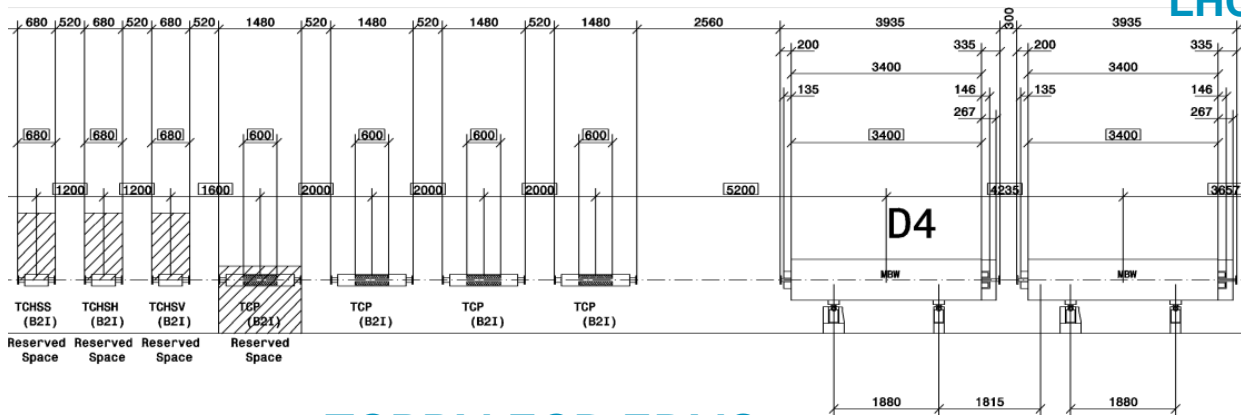

TCPM ECR EDMS 1973590

Thank you for
your attention.

SPARE SLIDES