



Development of μ -PIC with glass substrate aiming at high gas gain

Mitsuru Abe (Kyoto U.)

Toru Tanimori, Atsushi Takada, Yoshitaka Mizumura,
Shotaro Komura, Tetsuro Kishimoto, Taito Takemura,
Kei Yoshikawa, Yuta Nakamura, Yuma Nakamasu,
Tomoyuki Taniguchi, Ken Onozaka, Kaname Saito,
Tetsuya Mizumoto, Shinya Sonoda (Kyoto U.),
Joseph Parker (CROSS TOKAI), Kentaro Miuchi (Kobe U.),
Tatsuya Sawano (Kanazawa U.)



Contents

- Introduction
- **TGV (Through Glass Via) μ -PIC**
 - Test using X-ray sources
 - Results and problems
- Simulation study using Garfield++
 - Dielectric constants VS Gain
 - Dielectric discontinuous effects
- **TGV μ -PIC without polyimide film**
 - Tests and results
- Summary

MeV γ ray telescope

Directly investigate the existence and generation of RIs in the universe

Electron-Tracking Compton Camera (ETCC)

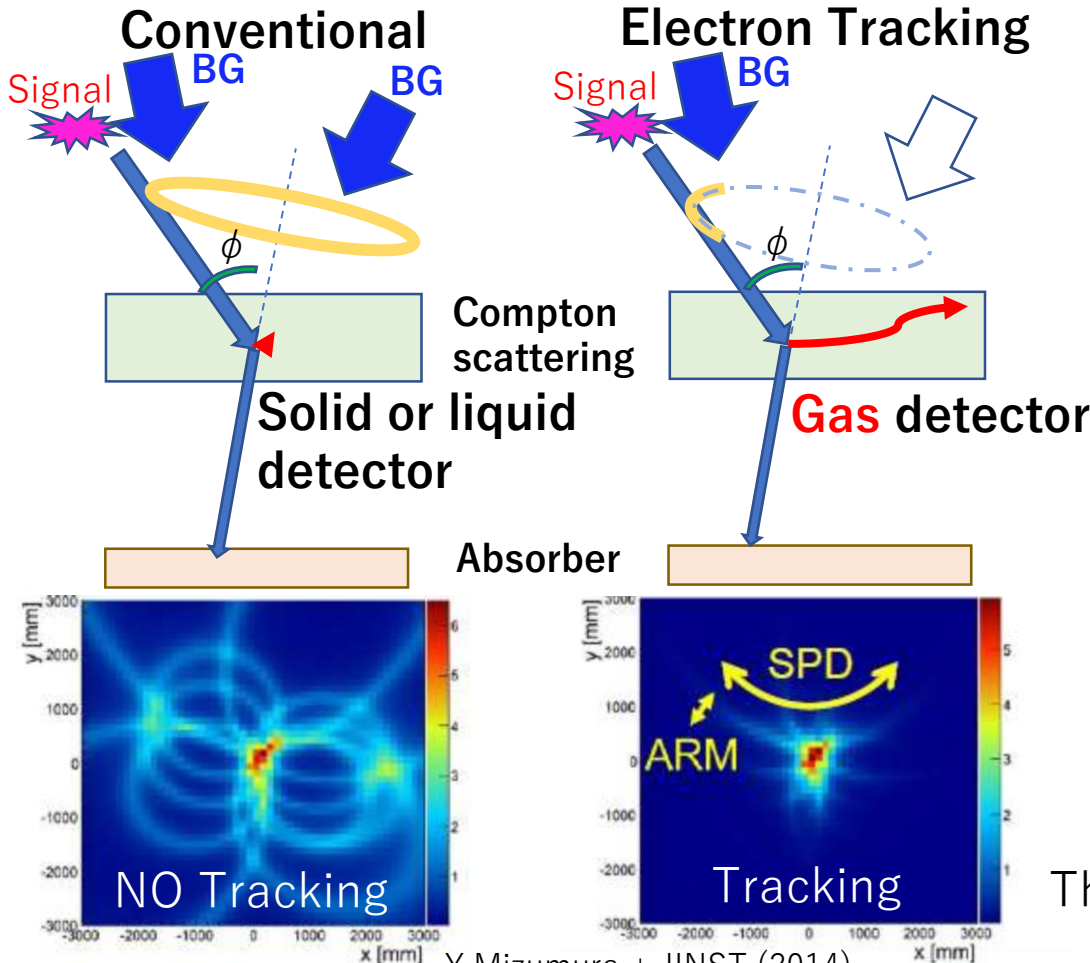

2019/5/6

MPGD2019 La Rochelle, France

Balloon experiment in 4/2018



Galactic diffuse & 511 keV

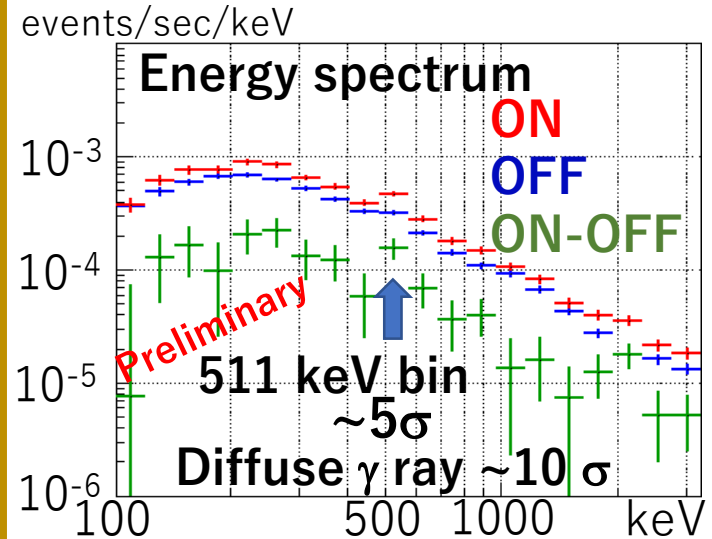

The superiority of the ETCC method is proven in space

μ -PIC

Requirements from ETCC :
3D tracking low energy e^-

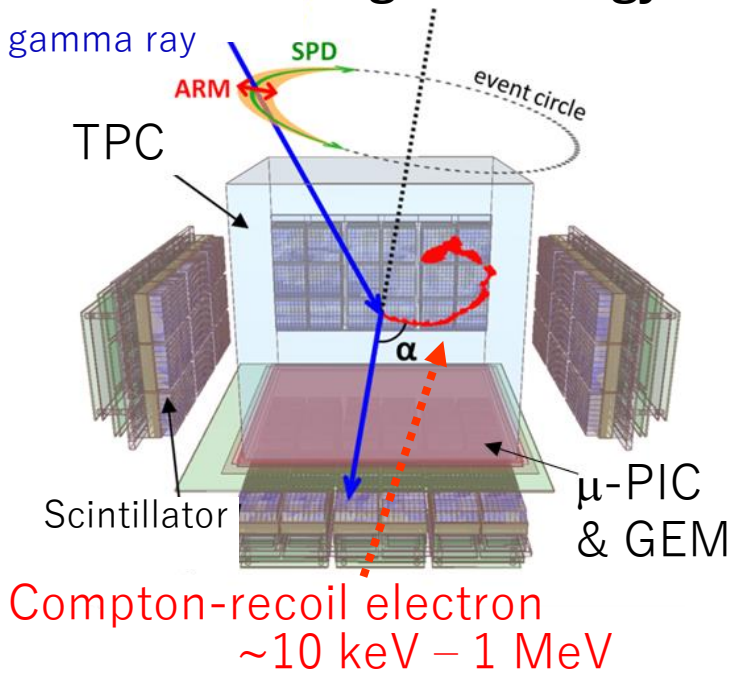

short track (~cm)
↑
sub mm sampling

MIP-like
↑
To detect,
gain of ~15,000
(Ar based gas, 1atm)

Feature of μ -PIC

- ✓ A gaseous 2D imaging detector with strip read out
- ✓ **Manufactured with printed circuit board (PCB) technology**
- ✓ Each pixel is place with a pitch of $400 \mu\text{m}$
- ✓ Fine position resolution (RMS - $120 \mu\text{m}$)
- ✓ Large detection area : $10 \times 10, 30 \times 30 \text{ cm}^2$
- ✓ Gas gain : $\sim 15,000$ (MAX, a moment)
 $\sim 6,000$ (stable, 1month)

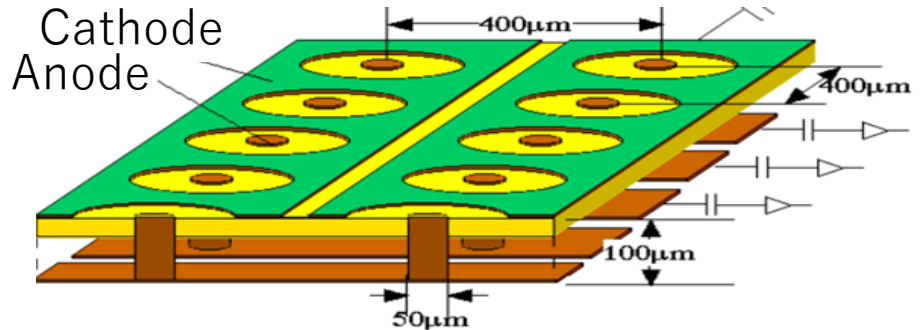

We temporary adopt
 μ -PIC+GEM
(Gain_{GEM} < 10)
↓
Only μ -PIC

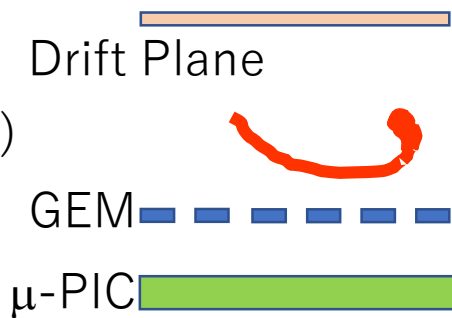

The more thickness, the more gain

PCB(Printed Circuit Board) μ -PIC

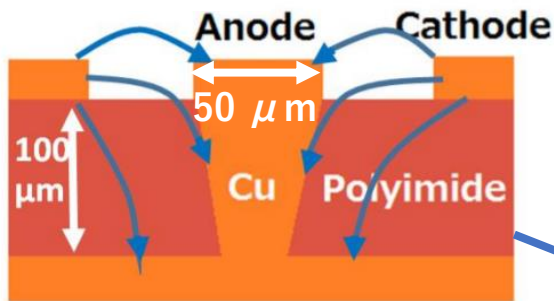

Gain VS Substrate thickness

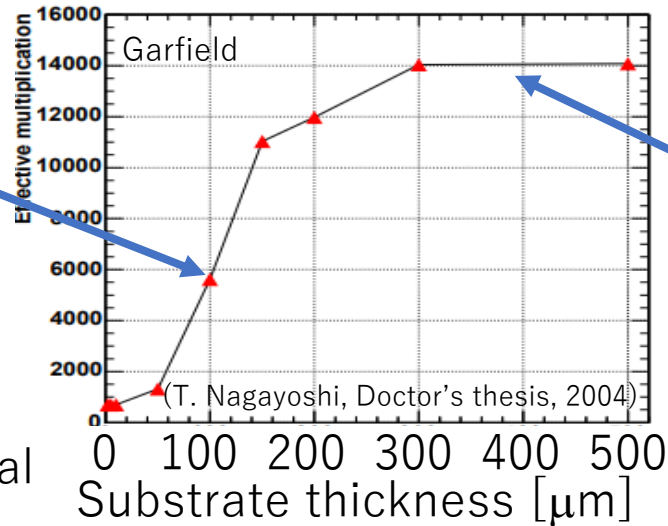

TSV(Through Silicon Via) μ -PIC

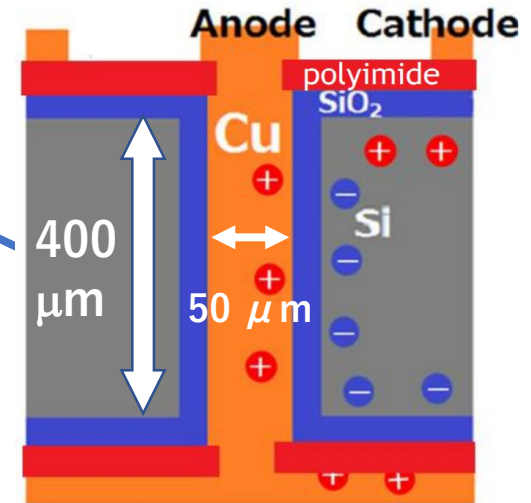

(T. Takemura et al, 2018)

Anode aspect ratio
(Thickness/Anode ϕ)
is limited by PCB technical
restrictions.

Up to $\sim 300 \mu\text{m}$,
Thickness \uparrow , Gas gain \uparrow

we focus on a glass substrate

- ✓ Insulator
- ✓ Inorganic
- ✓ capable of forming **high aspect ratio** anode via

but TSV operation had
instability

- charge transfer inside
the silicon substrate.
- Thickness of SiO_2 film
on side of anode via

TGV μ -PIC

Through **G**lass **V**ia

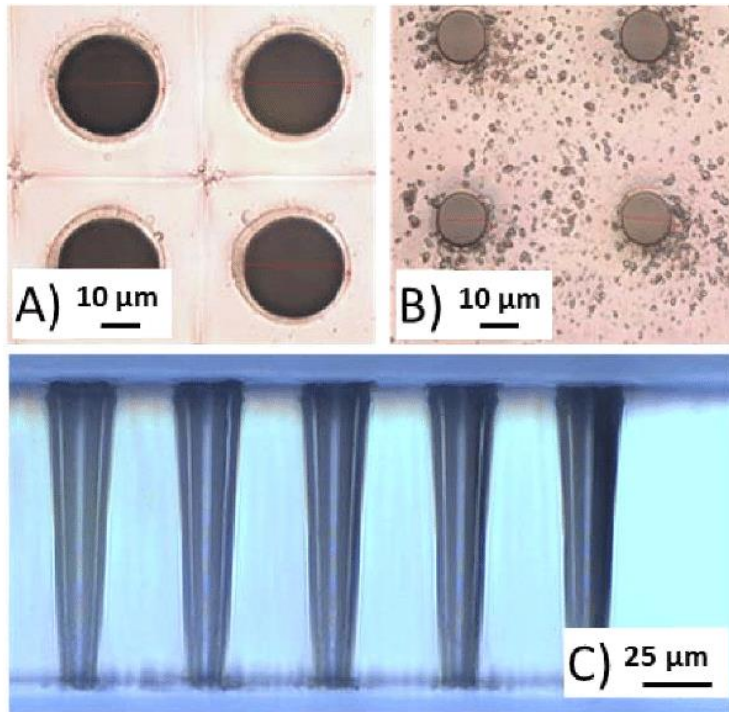

- ✓ Able to form **high aspect** ratio via
- ✓ Good **accuracy** ($\sim\mu$ m) thanks to MEMS processing technologies
- ✓ (Potentially) Having a **scalability**

(R. Delmdahl & R. Paetzel, "Laser Drilling of High-Density Through Glass Vias (TGVs) for 2.5D and 3D Packaging", 2014)

✘ Not a train



Train à Grande Vitesse

First prototype TGV μ -PIC

- Developed with DNP (Dai Nippon Printing Co., Ltd.)

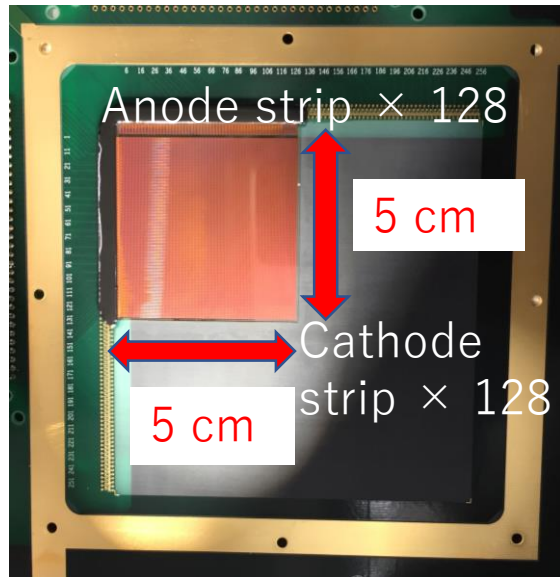

Microscope image

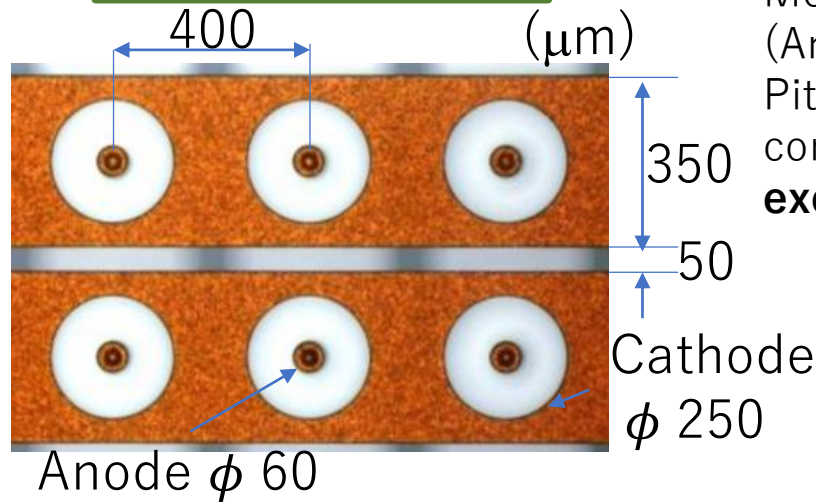

Most geometry parameters (Anode ϕ , Cathode ϕ , Pitch, ...) are **same** as for conventional μ -PIC, **except for the thickness.**

Polyimide thin film 5 μm

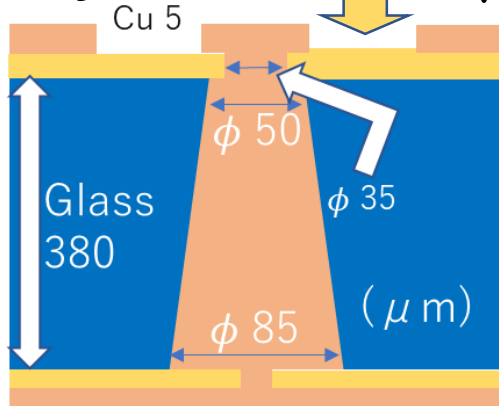

	PCB μ -PIC	TSV μ -PIC	TGV μ -PIC
Substrate material	Polyimide	Silicon	alkali-free glass
Dielectric constant	3.2 [1 MHz]	Si : 11 SiO ₂ : 4.5	5.8 [1 MHz]

Experiments & results

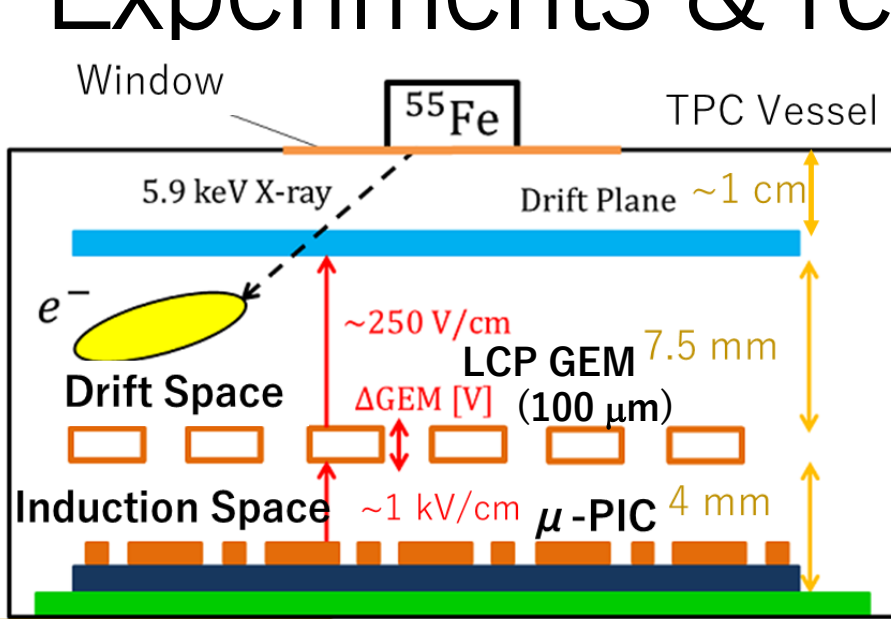

HV supply & read out $\text{Ar} : \text{C}_2\text{H}_6 = 90:10 (1\text{atm})$

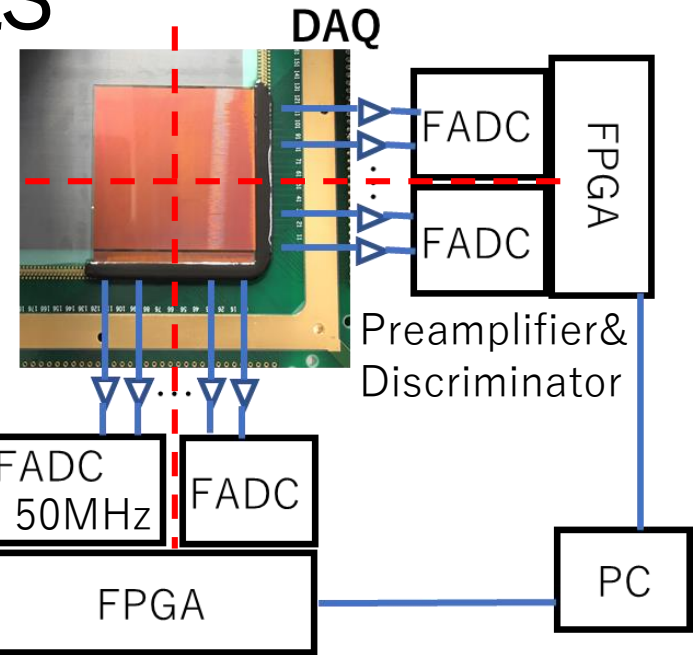

^{55}Fe Spectrum @ 2.5 cm \times 2.5 cm

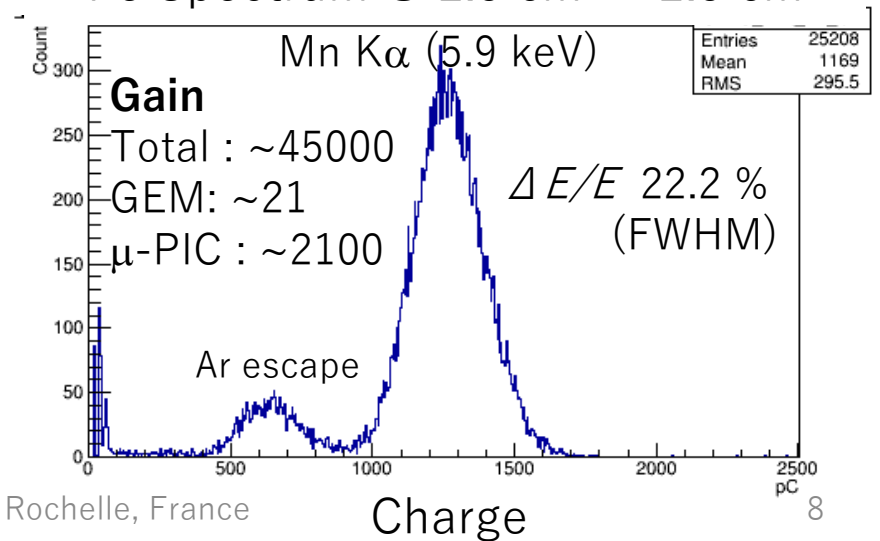
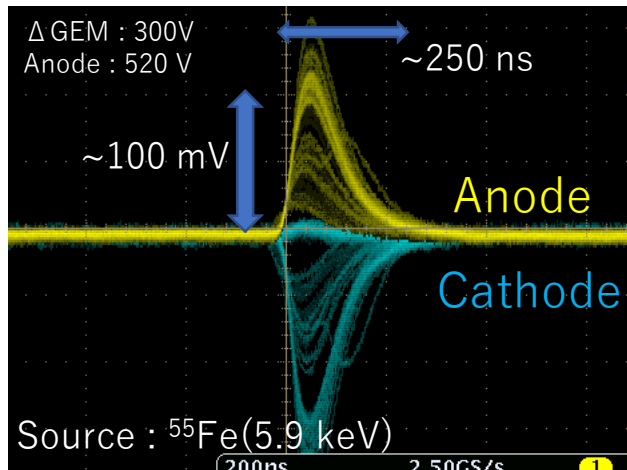

Gain curve

Gain of μ -PIC ($\text{Gain}_{\text{Total}}/\text{Gain}_{\text{GEM}}$)

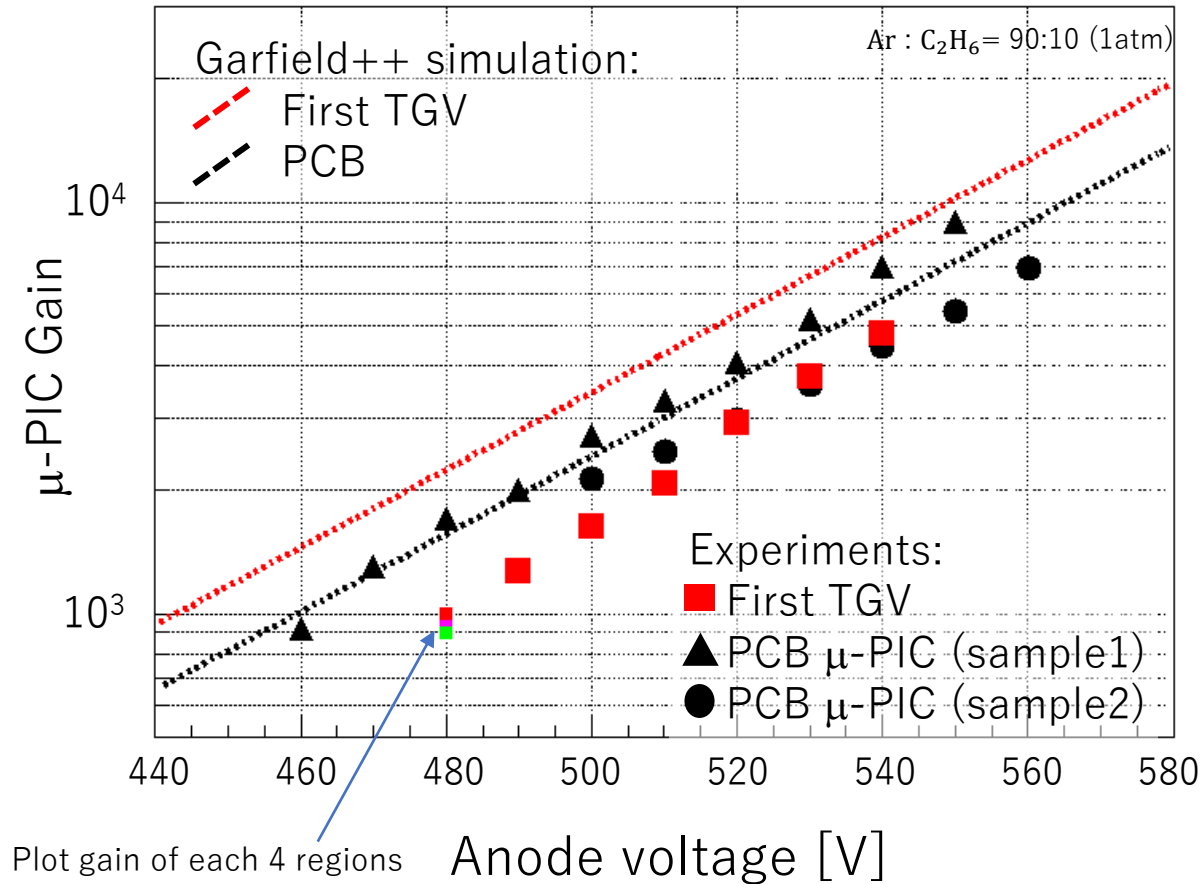

- The gain of TGV and PCB was **comparable**.
- In the first TGV, The experimental gain value was **$\sim 50\%$ lower** than the simulated gain value.

Why ?

Something that decreases the gain

Reference the product catalog

$\epsilon_{\text{alkali-free glass}}$: 5.8 [@1MHz]

Reflect reality??

It is difficult to measure ϵ at DC

Hypothesis : Effective dielectric constant > 5.8

Dielectric constant VS frequency

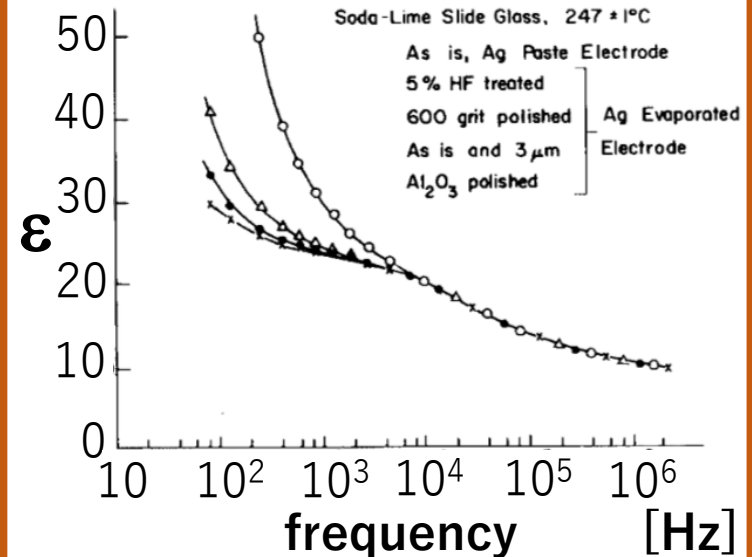

Electrode polarization at low frequency in a Soda lime glass
(C. Kim & M. Tomozawa, 1975)

Something that decreases the gain

Reference the product catalog

$\epsilon_{\text{alkali-free glass}} : 5.8$ [@1MHz]

Reflect reality??

It is difficult to measure ϵ at DC

Hypothesis : Effective dielectric constant > 5.8

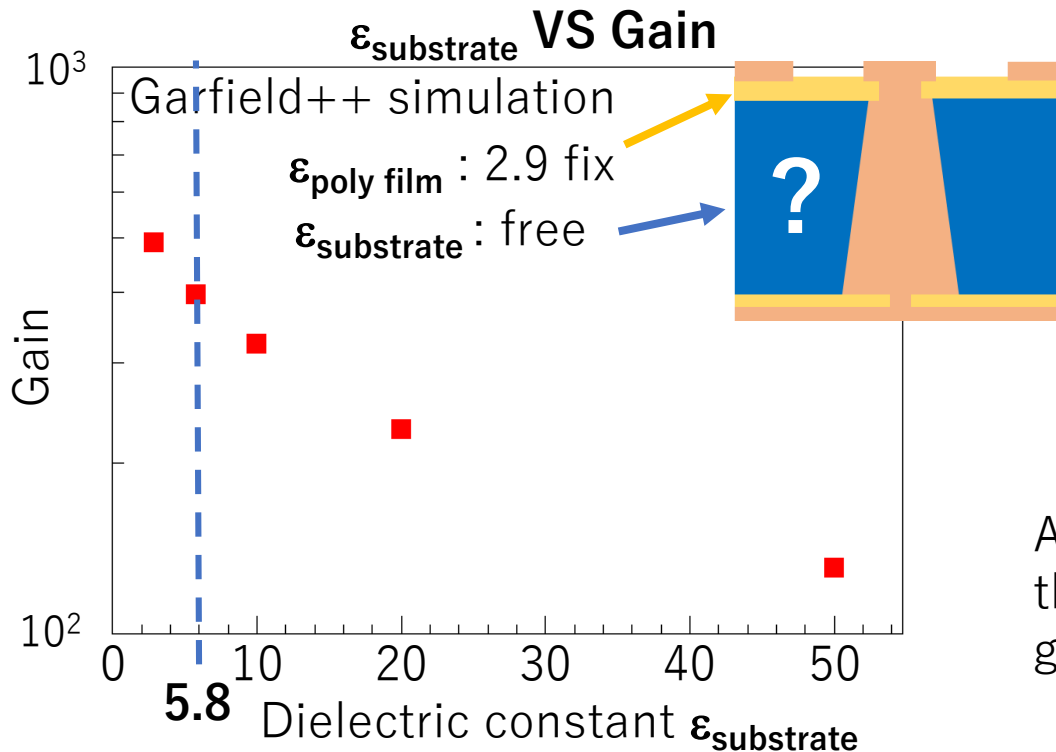

Dielectric constant VS frequency

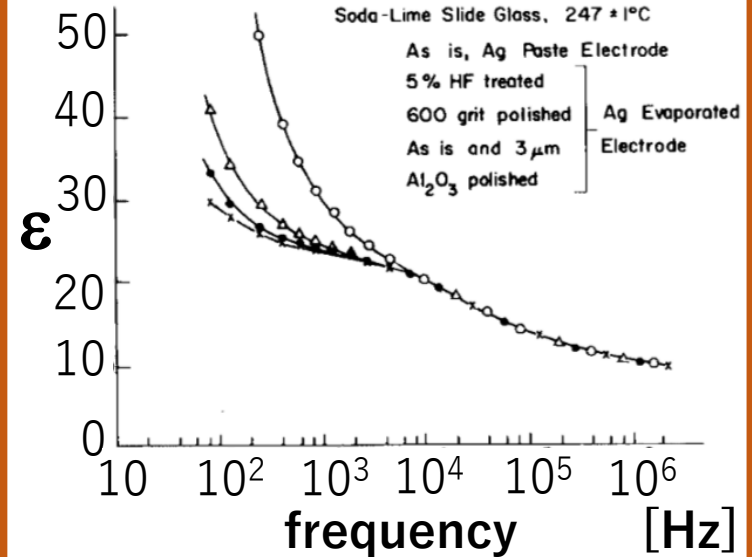

Electrode polarization at low frequency in a Soda lime glass
(C. Kim & M. Tomozawa, 1975)

As the dielectric constant of the substrate **increases**, the gas gain tends to **decrease**.

E field around the anode

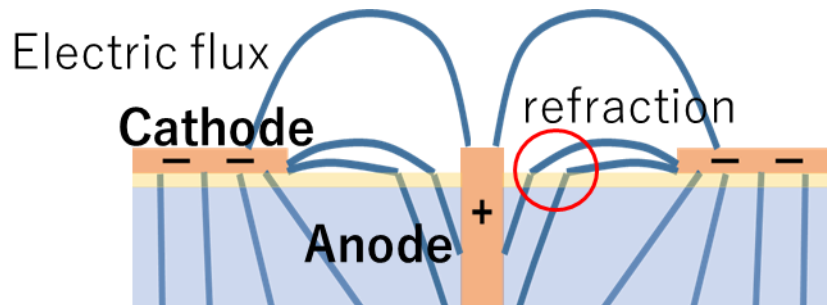
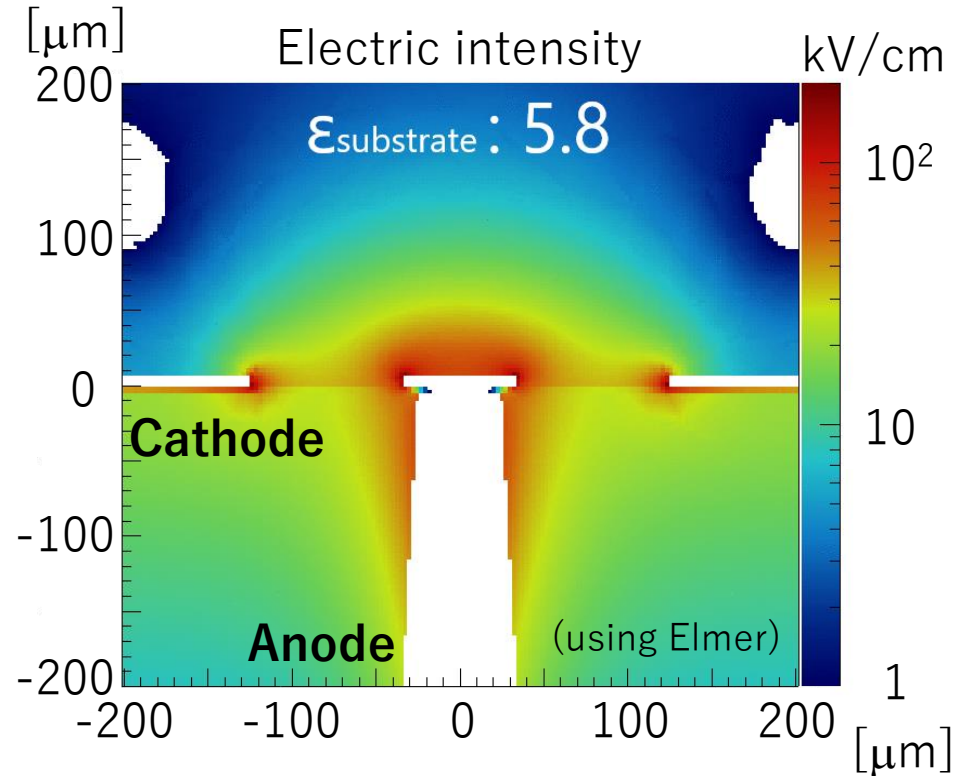
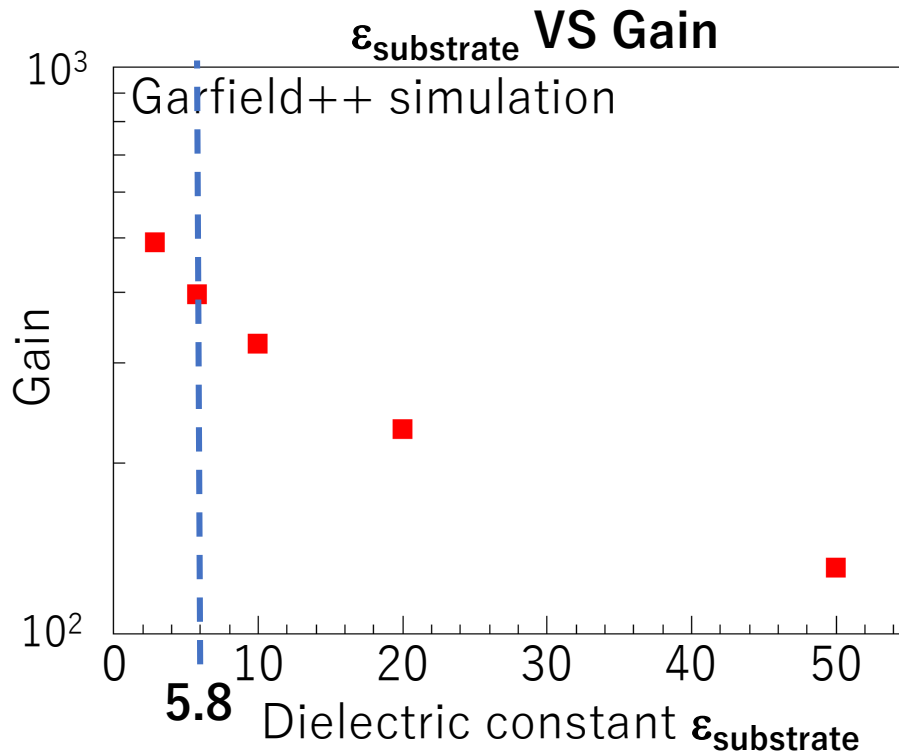

$$\epsilon_{\text{Gas}} \sim 1$$

$$\wedge$$

$$\epsilon_{\text{poly film}} \sim 2.9$$

$$\wedge$$

$$\epsilon_{\text{substrate}}$$

Dielectric discontinuous effects

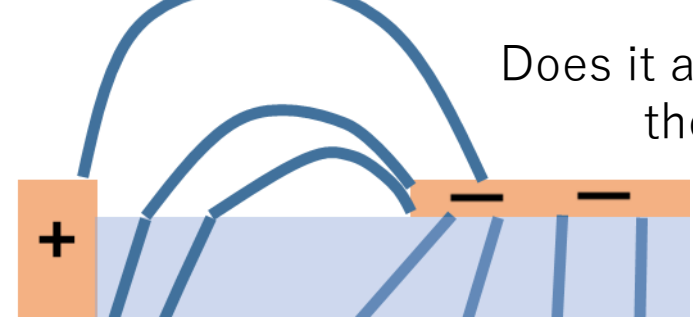
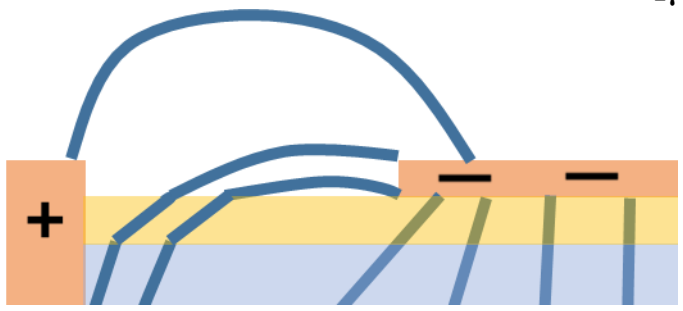
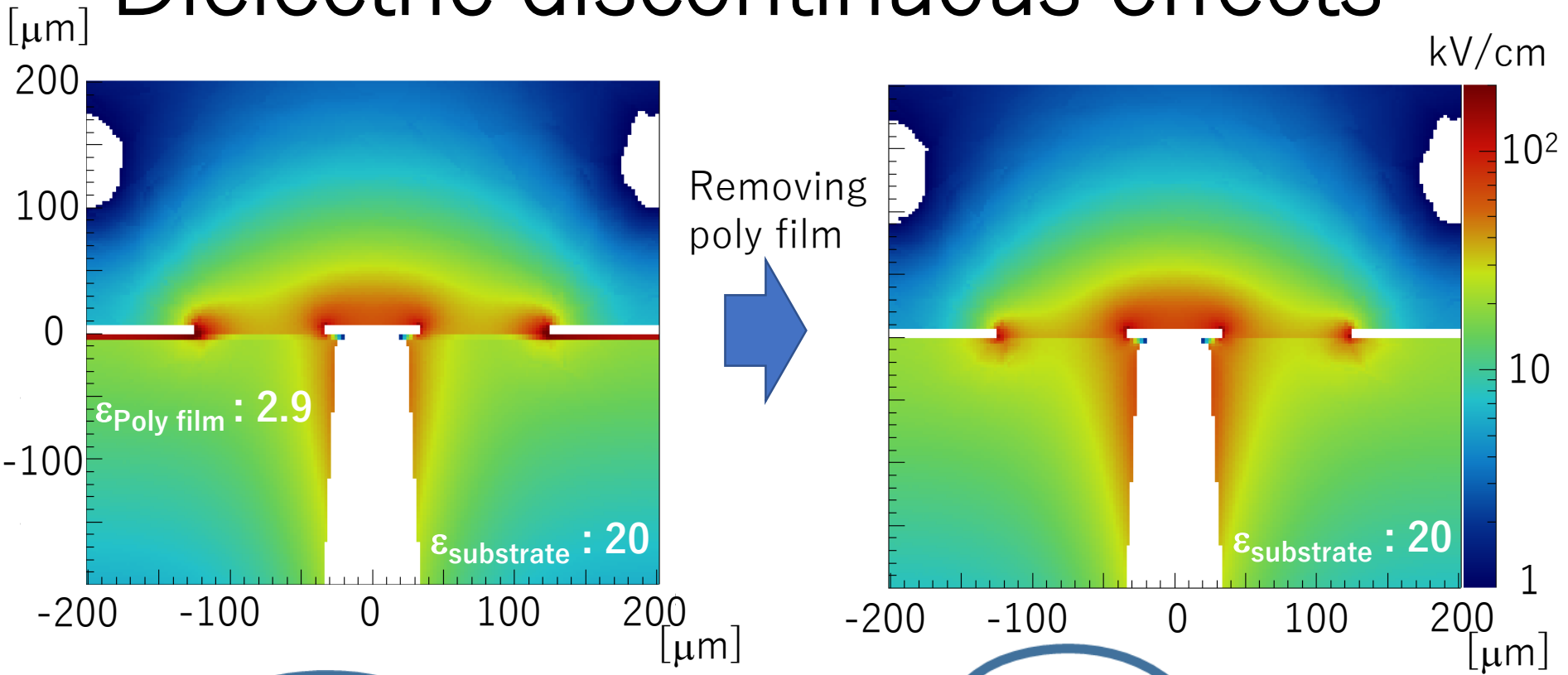

Does it affect the gain?

Dielectric discontinuous effects

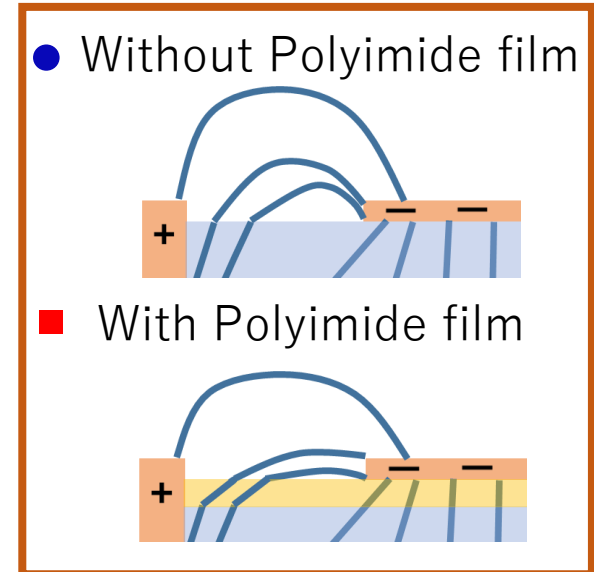
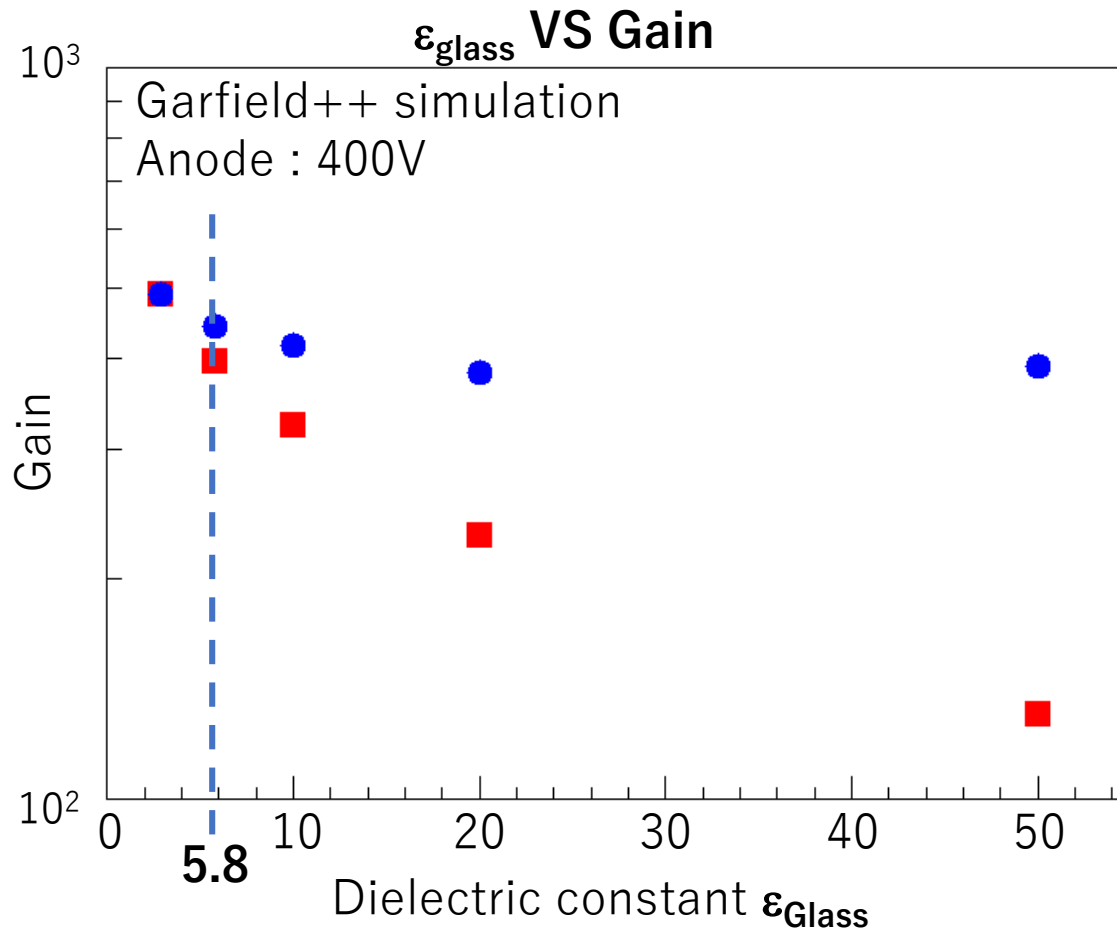

Dielectric discontinuous effects

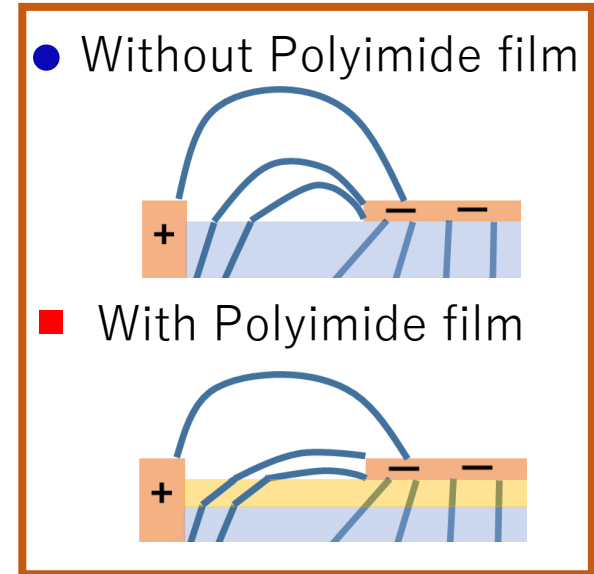
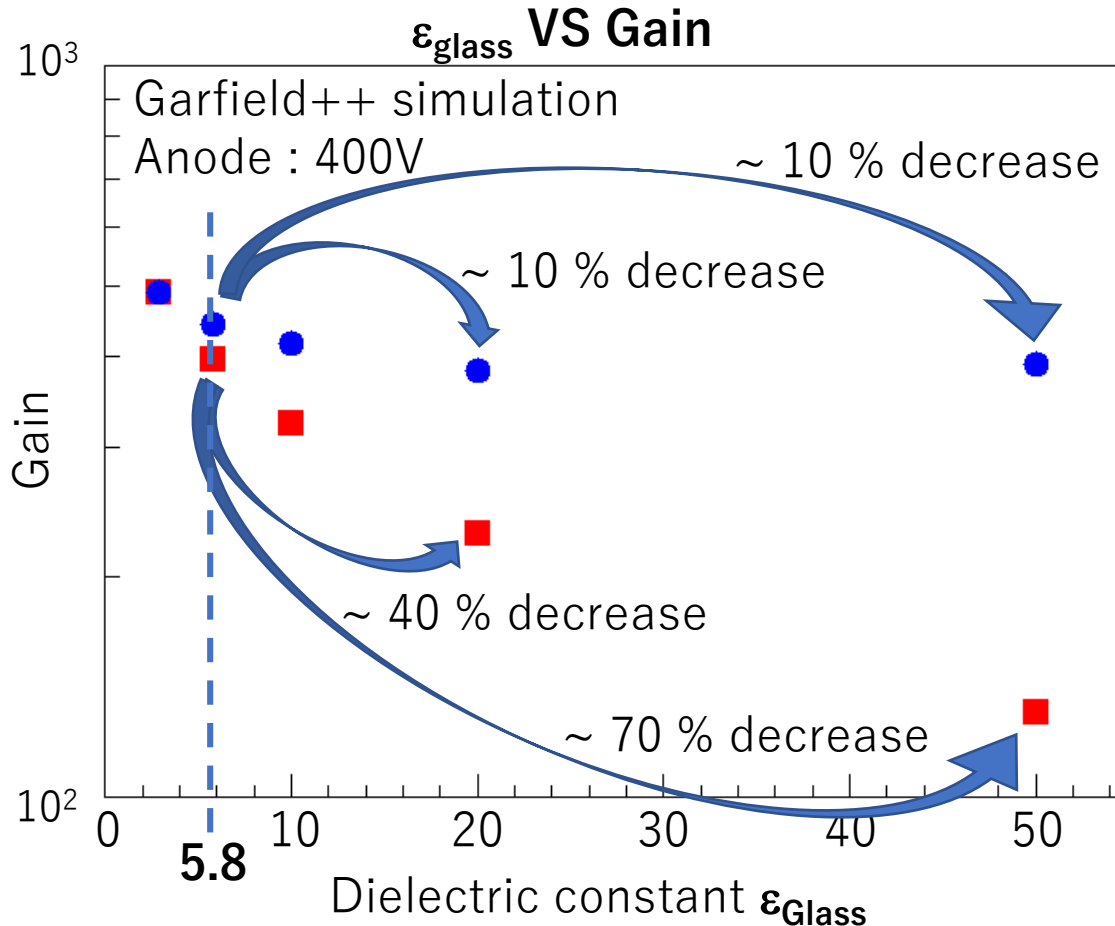

Trends found from simulation studies

- As the dielectric constant of the substrate **increases**, the gas gain tends to **decrease**.
- The **dielectric discontinuous** makes the gas gain **sensitive** to the value of the dielectric constant.

Let's remove the polyimide film!

TGV μ -PIC without polyimide film

- We fabricated second TGV μ -PIC without polyimide film.
- Geometry parameters (Anode ϕ , Cathode ϕ , Pitch, Detective area, ...) are same as for the first prototype TGV.
- Hollow anode vias do not affect the gas gain, that is confirmed by past experiments and simulation studies in TSV.

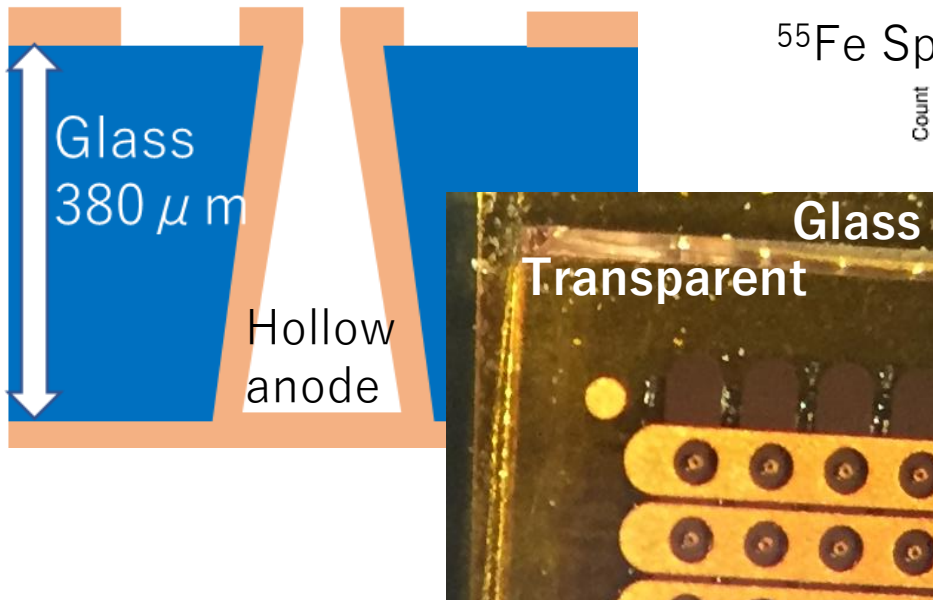
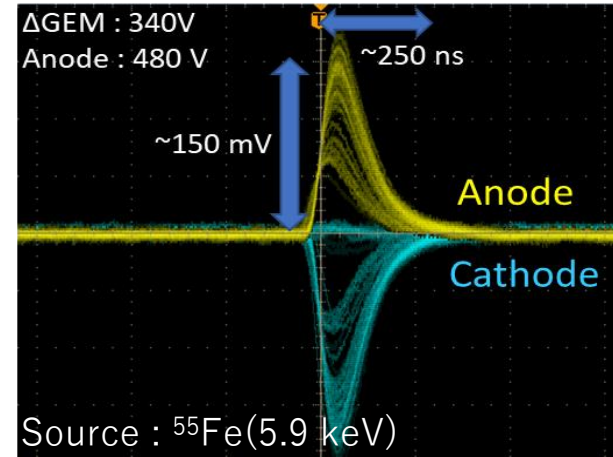

^{55}Fe Spectrum @ $2.5 \text{ cm} \times 2.5 \text{ cm}$ (~ 3100 pixel)

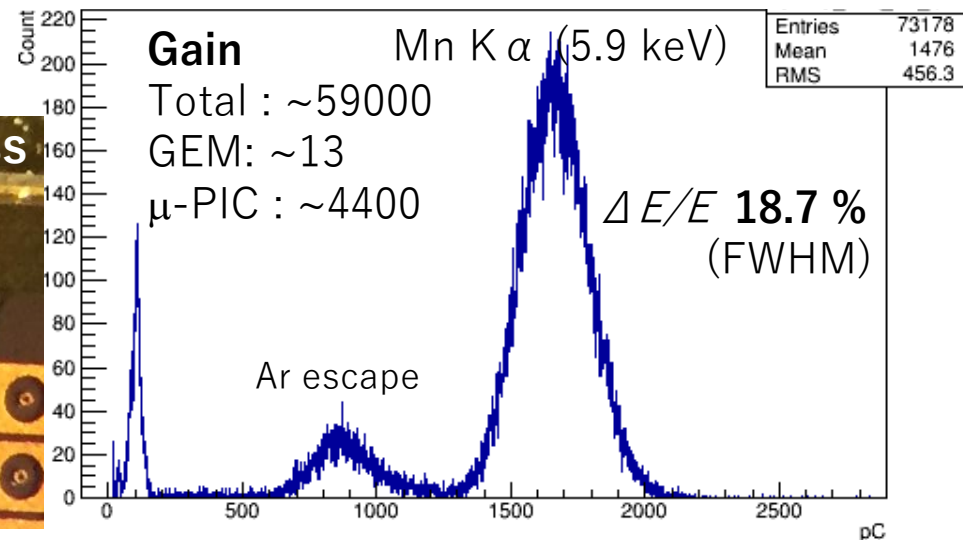

Gain curve

^{55}Fe Spectrum @ 2.5 cm × 2.5 cm

Gain of μ -PIC ($\text{Gain}_{\text{Total}}/\text{Gain}_{\text{GEM}}$)

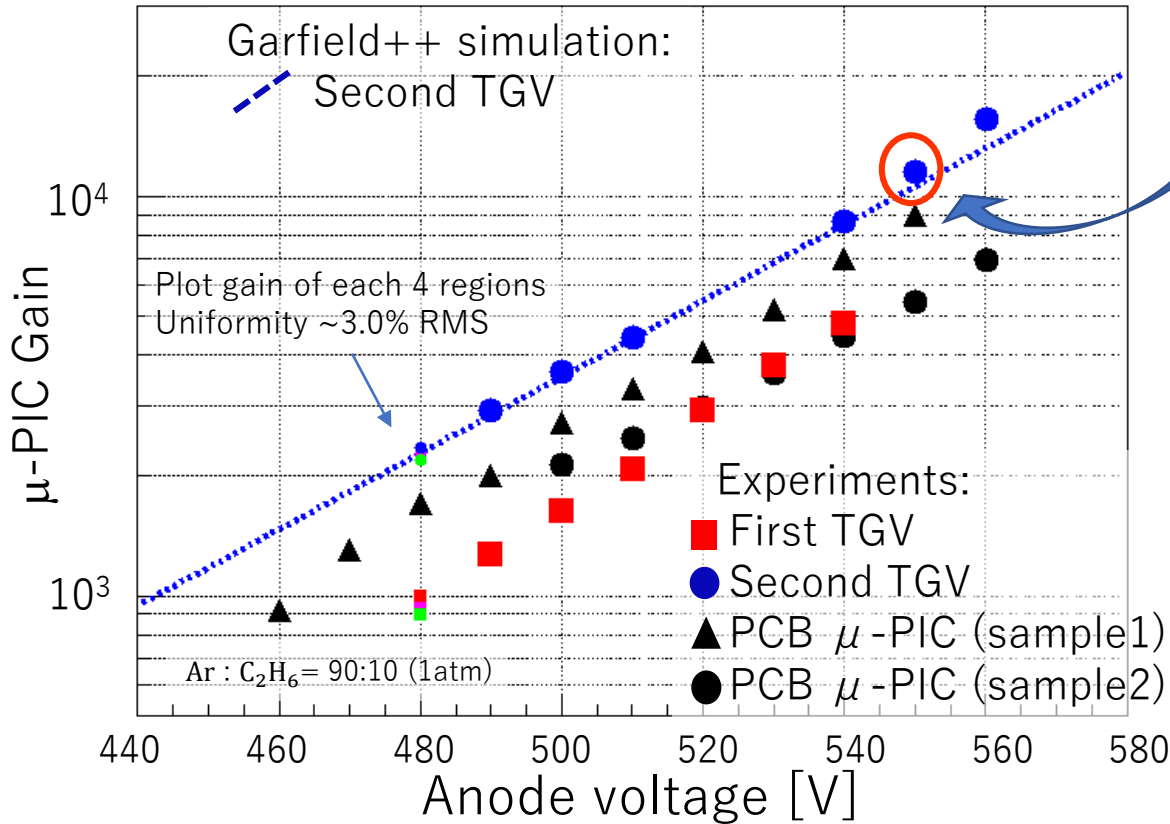

Clearly confirm
Ar escape

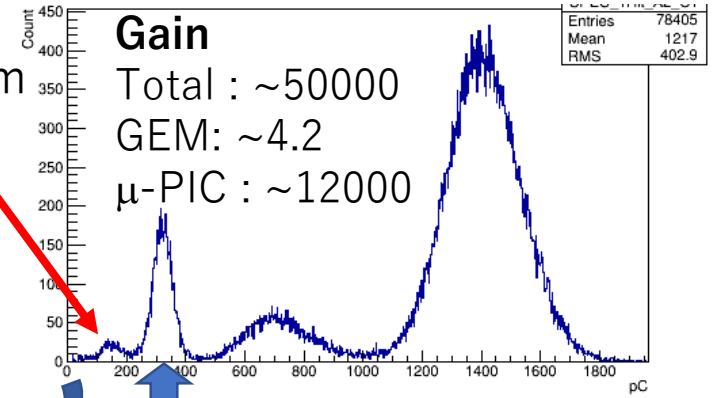

Absorbed in induction space

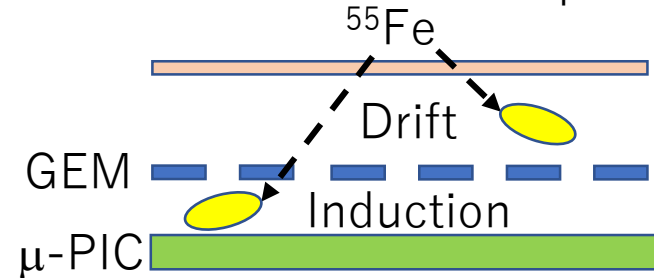

- The gain of the second TGV is about twice that of the first TGV.
- In the second TGV, the experimental and simulation gain values are consistent.

Summary

- We are developing a μ -PIC for the MeV gamma-ray telescope
- We manufactured two types of the μ -PIC using a glass substrate with DNP aiming at high gas gain
- The gain of the second TGV μ -PIC without the polyimide film was about twice as high as the first TGV with the polyimide film.
- The gain of the second TGV μ -PIC reached $\sim 15,000$ (discharges rates ~ 1 / several min)
- It was found from Garfield++ simulation study that the dielectric constants discontinuous makes the gas gain sensitive to the value of the dielectric constant.

Thanks to DNP for the development and manufacturing

Future works

- Feasibility study of manufacturing large detection area ($> 30 \times 30 \text{ cm}^2$) TGV μ -PIC using a glass panel
- Long term modulation & Charge-up on substrates by irradiation of high intensity radiation
- Study of μ -PIC + mesh (mesh selection, stable operating voltage setting, gain uniformity, ...)