

TauFV: a fixed-target experiment to search for flavour violation in tau decays

I. Bezshyiko, A. Buonaura and N. Serra, University of Zurich;
P. Collins and R. Jacobsson, CERN; A. Golutvin, Imperial College;
K. Petridis, University of Bristol; L. Shchutska, ETHZ;
G. Wilkinson, University of Oxford

With many thanks to the BDF team, in particular C. Ahdida, M. Calviani, J. P. Canhoto Espadanal, M. Casolino, Y. Dutheil, B. Goddard, E. Lopez Sola & A. Milanese. Also to M. Campbell & J. Buytaert from CERN EP-ESE.

‘Towards the Ultimate Precision in Flavour Physics’, IPPP, 4 April 2019

Contents

- Tau LFV: physics motivation
- Signal yields and background challenges
- Other physics opportunities
- Layout
- Beam profile and target region
- Background suppression
- Location, beam and environment studies
- Key detector elements: VELO, TORCH and ECAL
- Next steps and timescale
- Conclusions

Physics introduction

Long-standing, and well motivated (particularly since the discovery of neutrino oscillations) programme of searches for charged Lepton Flavour Violation.

Less stringent limits in 3rd generation, but here BSM effects may be higher.



Let's take $\tau \rightarrow \mu\mu\mu$ as benchmark mode. Current best 90 % CL limits:

Belle	2.1×10^{-8}	[PLB 687 (2010) 139]
BaBar	3.3×10^{-8}	[PRD 81 (2010) 111101]
LHCb	4.6×10^{-8}	[JHEP 02 (2015) 121]

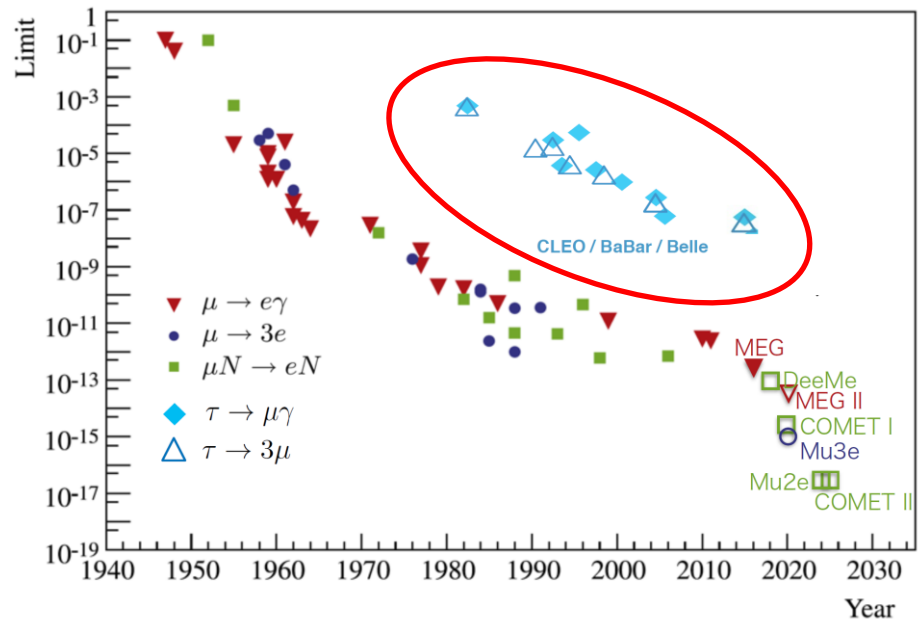

Most improvement in coming decade is expected from Belle II, who can reach 1×10^{-9} [arXiv:1011.0352] and will do even better if they achieve ~zero bckgd [arXiv:1808.10567].

Added motivation for LFV searches

Charged LFV searches are a sensitive BSM probe & hence are of great intrinsic interest.

However recent hints of lepton-universality violation (LUV), both in tree level decays ($R(D)$, $R(D^*)$) and in loops (R_K , R_{K^*}) give additional incentive.

Many commentators agree

LUV \leftrightarrow LFV !

Moreover, many predictions point to 10^{-10} in tau decays as an interesting regime for effects to manifest themselves.

See e.g. Feruglio, Paradisi, Pattori, PRL 118 (2017) 011801; Crivellin *et al.* PRD 92 (2015) 054013; Greljo, Isidori and Marzocca, arXiv:1506.01705; Feruglio, Paradisi and Pattori, JHEP 09 (2017) 061.

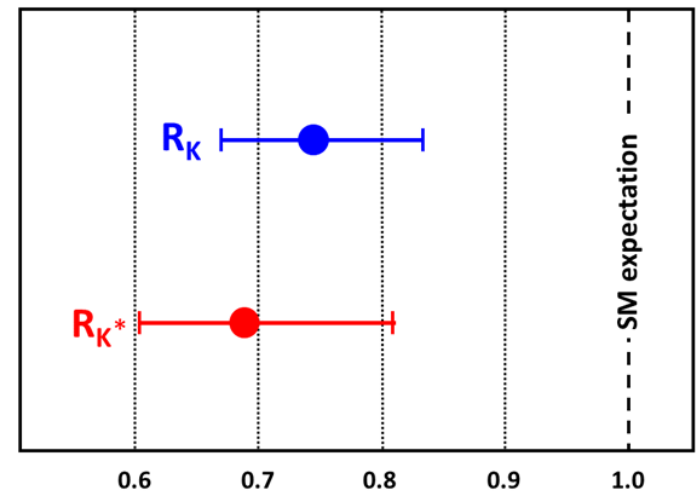
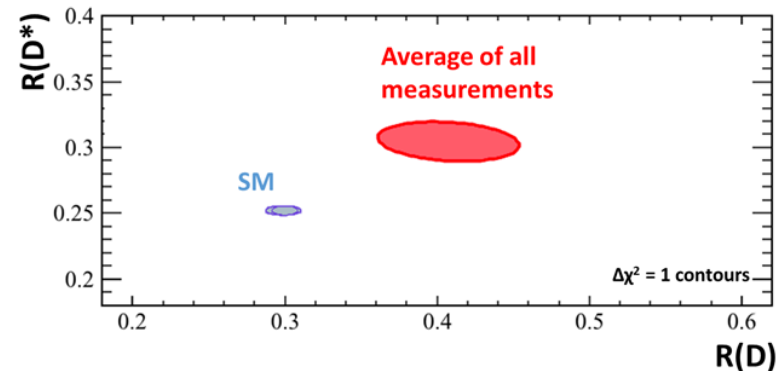

Physics opportunity: LFV τ decays at the SPS

Enormous τ production rate in SPS beam from $D_s \rightarrow \tau \nu$! Consider possibility of using Beam Dump Facility (BDF) being planned at CERN. However SHiP target unsuited for searches for ultra-rare τ decays, because of excessive multiple scattering.

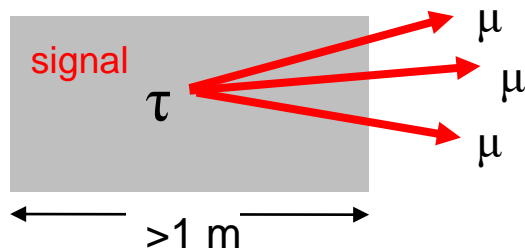

impossible to distinguish from...

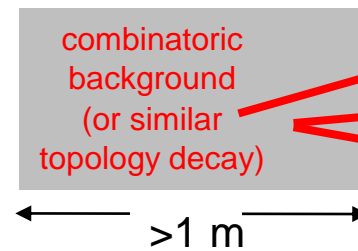

...due to lack of useful vertexing and poor mass resolution

Instead, design dedicated experiment upstream of SHiP, with thin, distributed targets, to bleed off $\sim 2\%$ of the beam intended for SHiP \rightarrow 2 mm of tungsten (this value also set by upper limit of data rates in VELO).

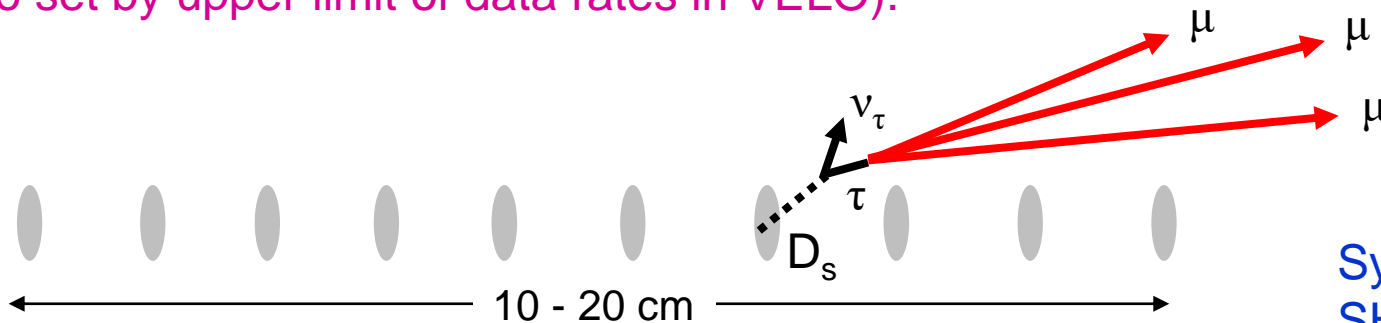

Synergetic with SHiP operation !

Signal yields, and comparisons with other experiments

With 2 mm of W we expect 4×10^{18} PoT in 5 years of operation.
0.17 % of interactions will produce charm, from this expect:

$$8 \times 10^{13} D_s \rightarrow \tau \nu \text{ decays}$$

Comparing to past and existing flavour experiments:

- $\sim 10^2$ times number produced at LHCb IP in runs 1 & 2;
- $\sim 10^5$ times number of $\tau^+\tau^-$ pairs produced during operation of Belle.

Moreover, production is strongly forward peaked, allowing a reasonable detector geometry to collect $\sim 50\%$ of all $\tau \rightarrow \mu\mu\mu$ decays. Assuming a total efficiency of 10% for geometrical selection and basic reconstruction cuts, and taking as a benchmark $BR(\tau \rightarrow \mu\mu\mu) = 1 \times 10^{-9}$, then the following yields are expected.

Future experiment	Yield	Extrapolated from
TauFV (4×10^{18} PoT)	8000	Numbers on this slide
Belle II (50 ab^{-1})	9	PLB 687 (2010) 139
LHCb Upgrade I (50 fb^{-1})	140	JHEP 02 (2015) 121
LHCb Upgrade II (300 fb^{-1})	840	ditto

Clear opportunity to benefit from higher signal yield than at any other facility !

Signal yield isn't everything

τ LFV searches at Belle II will be extremely clean, with very little background (if any), thanks to pair production and double-tag analysis technique. In contrast, TauFV (& hadron collider experiments) must contend with two background sources.

1) Combinatorics

e.g. from wrong association of EM produced dimuons and with muon from D decay...

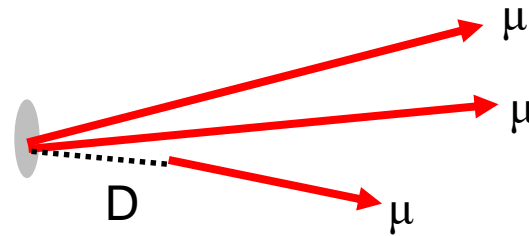

...or mis-association of genuine muon with decays in flight or punch through...

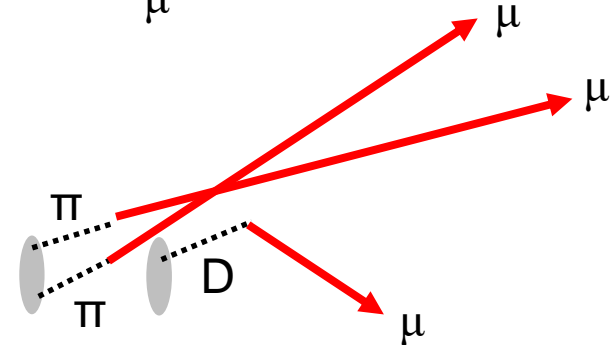

...or random association of three decays in flight *etc.*

Signal yield isn't everything

τ LFV searches at Belle II will be extremely clean, with very little background (if any), thanks to pair production and double-tag analysis technique. In contrast, TauFV (& hadron collider experiments) must contend with two background sources.

2) Specific backgrounds

Genuine tri-muon vertices arise from D and D_s semi-leptonic decays, followed by an EM transitions, e.g. $D_s \rightarrow \eta(\mu\mu\gamma)\mu\nu$

Background modes normalised to $D_s \rightarrow \eta(\mu\mu\gamma)\mu\nu$ (BR $\sim 10^{-5}$)

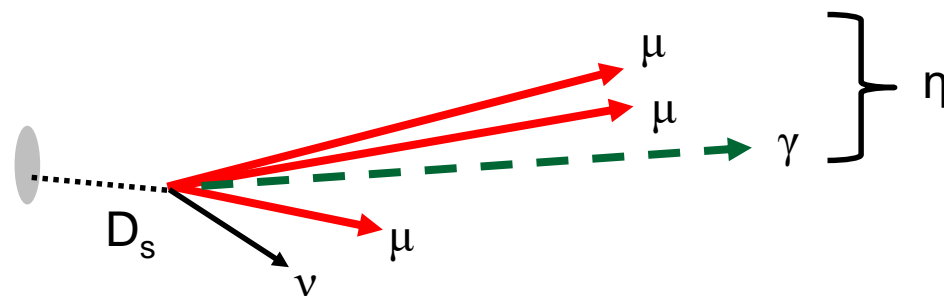

Decay channel	Relative abundance
$D_s \rightarrow \eta(\mu\mu\gamma)\mu\nu$	1
$D_s \rightarrow \phi(\mu\mu)\mu\nu$	0.87
$D_s \rightarrow \eta'(\mu\mu\gamma)\mu\nu$	0.13
$D \rightarrow \eta(\mu\mu\gamma)\mu\nu$	0.13
$D \rightarrow \omega(\mu\mu)\mu\nu$	0.06
$D \rightarrow \rho(\mu\mu)\mu\nu$	0.05

Other LFV/LNV physics

Other LFV tau decays which are natural goals for TauFV

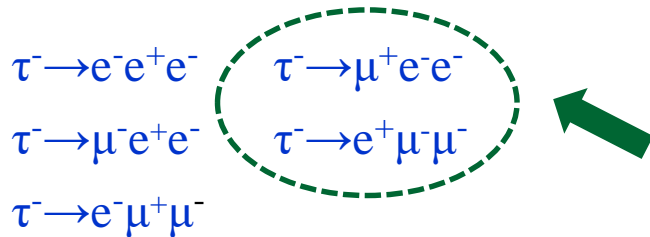

note that these decays have much lower backgrounds, so here extremely high sensitivity expected

In addition, there will be a correspondingly large sample of charm decays (e.g. $\sim 5 \times 10^{15}$ D⁰s produced, which is 10^5 times more than at Belle II).

→ super precise *lepton number violation* studies in both tau and charm decays

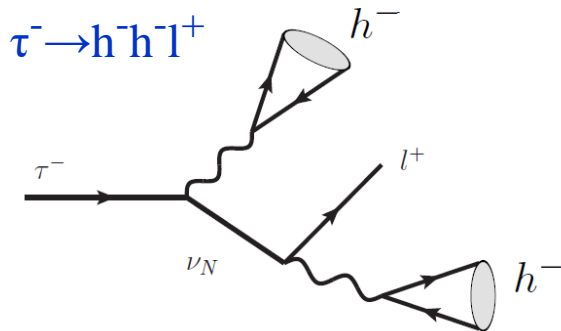

(and not to forget LFV D decays, e.g. $D \rightarrow h \mu^- e^+$)

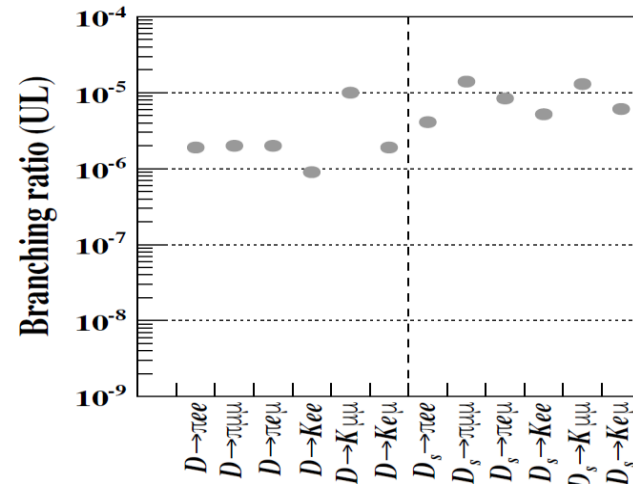

And maybe also opportunities in kaon LFV decays, such as $K^+, K_L \rightarrow \pi \mu e$.

Charm physics

As remarked, there will be a correspondingly large sample of charm decays (e.g. $\sim 5 \times 10^{15}$ D^0 s produced, which is 10^5 times more than at Belle II)

→ will allow for an extensive programme of CPV studies & rare decay searches

Excellent performance expected in many benchmark studies:

- Direct CPV in charged modes – exploit hadron ID from TORCH
- Rare decays, e.g. $D^0 \rightarrow \mu\mu$
- Indirect CPV studies

Soft ECAL based physics – potential for world-leading measurements:

- CPV studies with neutrals, e.g. $D \rightarrow \pi\pi^0$
- CPV studies with radiative Penguins, e.g. $D \rightarrow V\gamma$
- Rare decays with neutrals, e.g. $D \rightarrow \gamma\gamma$ (10^{-8} in SM, which is just beyond Belle II's reach). Feasibility to be evaluated – relies on ECAL fast timing).

TauFV layout

Half-view schematic of a *possible* TauFV configuration (non bending plane).

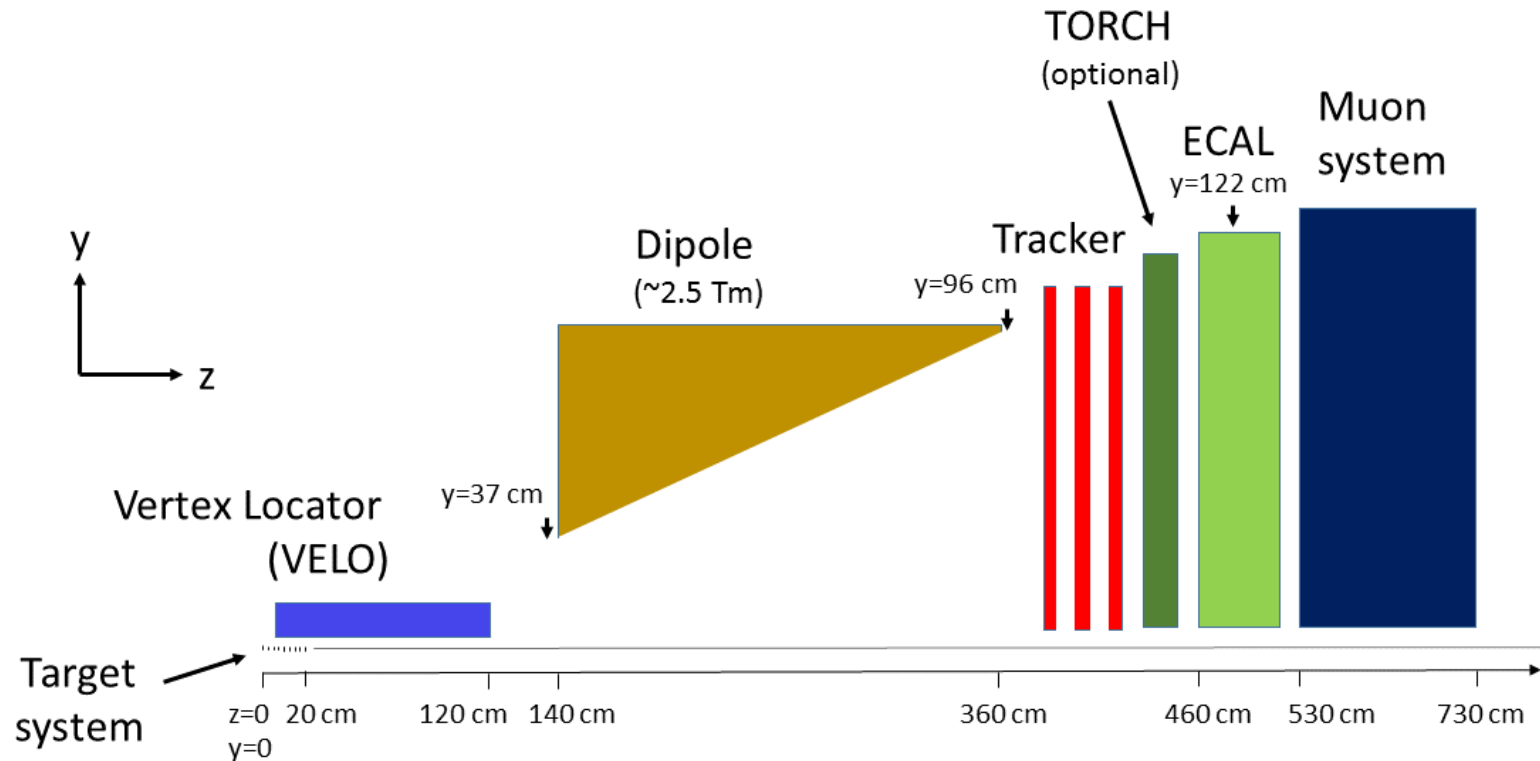

Angular acceptance: $20 \rightarrow 260$ mrad (geometrical efficiency $\sim 40\%$ for $\tau \rightarrow \mu\mu\mu$).

Beam profile and target arrangement

Key idea:

Squeeze beam profile to make compatible with wire (or blade)-like target

one possibility

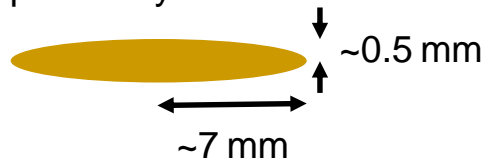

Allows for several wires, with much reduced shadowing effects compared to circular profile and disc-like targets.

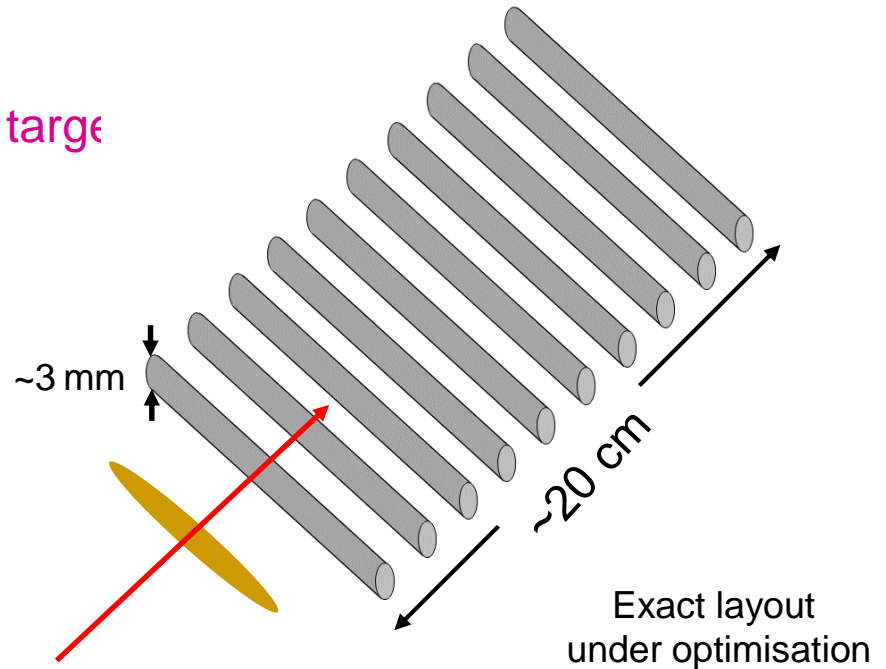

Advantages of distributed target system and wide beam in one dimension:

- Separates out interactions \rightarrow invaluable for combinatoric bckgd suppression.
- Mild benefits for damping peak rates and dose in VELO.

Target and VELO region

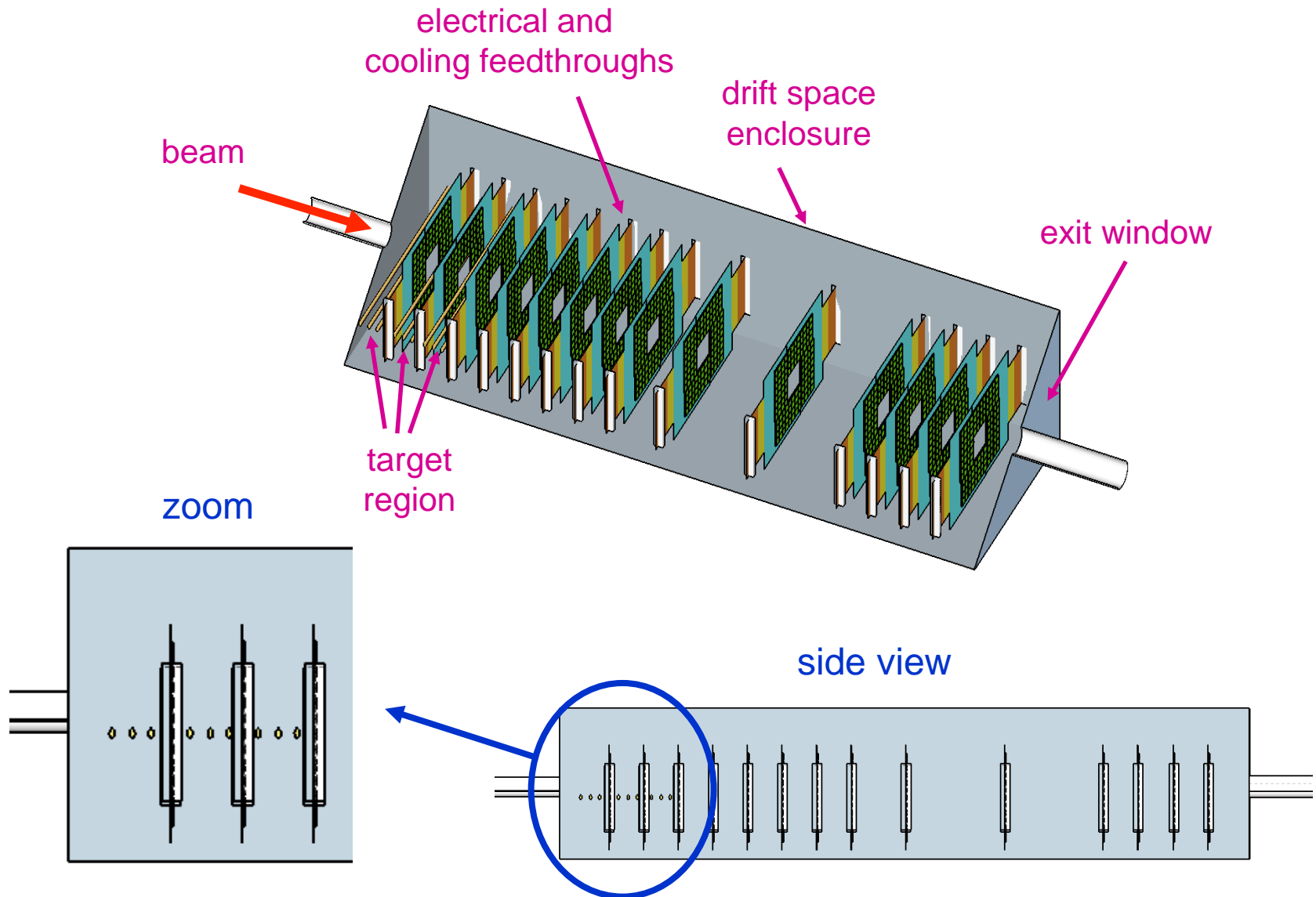

$\tau \rightarrow \mu\mu\mu$: combatting combinatoric background

Suppressing this background relies on usual tools of a flavour-physics experiment, in particular:

- high performance vertex detector
- good mass resolution

Muon candidates must possess good quality vertex, downstream of target, and tracks must have impact parameter relative to found interaction vertices.

Distributed target and wide beamspot very helpful in distributing out interactions and reducing fake combinations !

Also essential is role of *fast timing* provided by VELO, TORCH (~ 20 ps) and ECAL. Spill takes place over ~ 1 s and so precision timing gives *extremely powerful discrimination* between random associations.

Studies ongoing, but current results indicate this background will be sub-dominant and have very small impact on $\tau \rightarrow \mu\mu\mu$ search, even down to BRs of 1×10^{-10} !

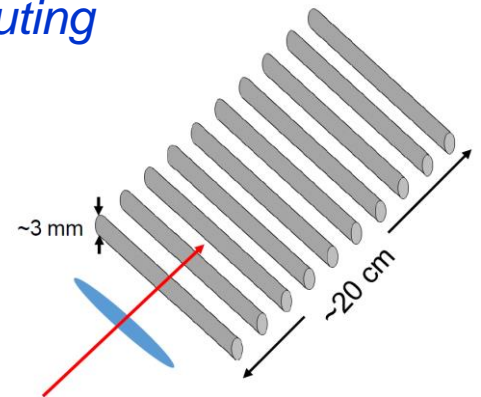
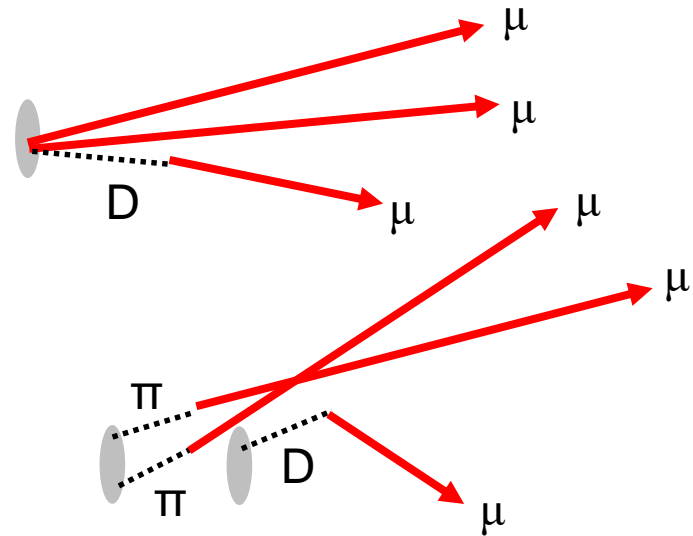

$\tau \rightarrow \mu\mu\mu$: combatting charm backgrounds

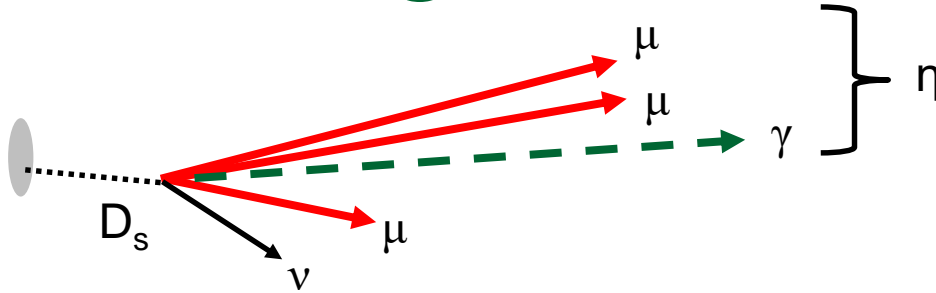

Mode	Relative abundance
$D_s \rightarrow \eta(\mu\mu\gamma)\mu\nu$	1
$D_s \rightarrow \phi(\mu\mu)\mu\nu$	0.87
$D_s \rightarrow \eta'(\mu\mu\gamma)\mu\nu$	0.13
$D \rightarrow \eta(\mu\mu\gamma)\mu\nu$	0.13
$D \rightarrow \omega(\mu\mu)\mu\nu$	0.06
$D \rightarrow \rho(\mu\mu)\mu\nu$	0.05

These backgrounds afflict $\tau \rightarrow \mu^+\mu^-\mu^-$ searches in hadronic environment (but are absent for modes such as $\tau \rightarrow \mu^+e^-e^-$). Various tools are available.

- Invariant mass of candidate

Provides suppression factor of up to 100, depending on mode.

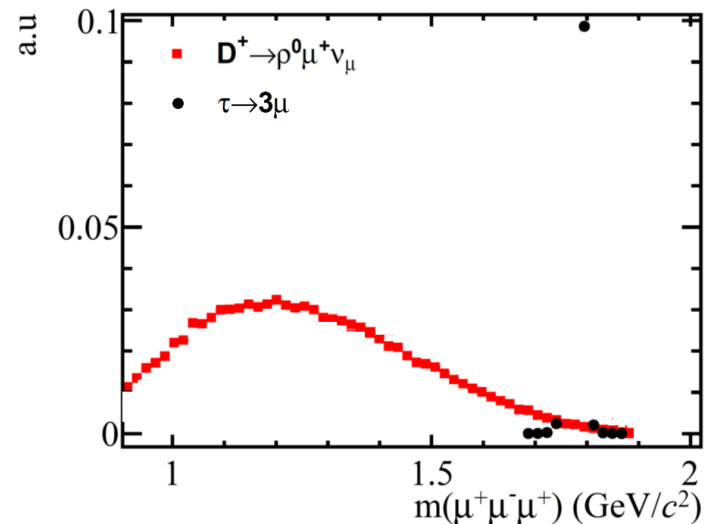

$\tau \rightarrow \mu\mu\mu$: combatting charm backgrounds

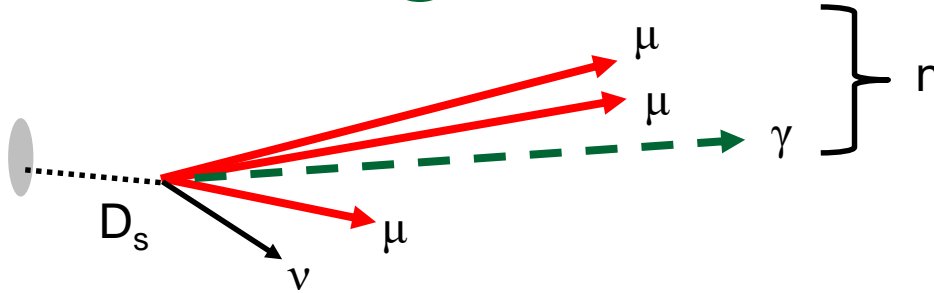

Mode	Relative abundance
$D_s \rightarrow \eta(\mu\mu\gamma)\mu\nu$	1
$D_s \rightarrow \phi(\mu\mu)\mu\nu$	0.87
$D_s \rightarrow \eta'(\mu\mu\gamma)\mu\nu$	0.13
$D \rightarrow \eta(\mu\mu\gamma)\mu\nu$	0.13
$D \rightarrow \omega(\mu\mu)\mu\nu$	0.06
$D \rightarrow \rho(\mu\mu)\mu\nu$	0.05

These backgrounds afflict $\tau \rightarrow \mu^+\mu^-\mu^-$ searches in hadronic environment (but are absent for modes such as $\tau \rightarrow \mu^+e^-e^-$). Various tools are available.

- Invariant mass of candidate
- Invariant mass of dimuon pairs

Can essentially eliminate *all* backgrounds (apart from wide ρ), whilst retaining 25% of signal, assuming phase space decay.

But this a 'blunt weapon' as introduces model-dependence into result.

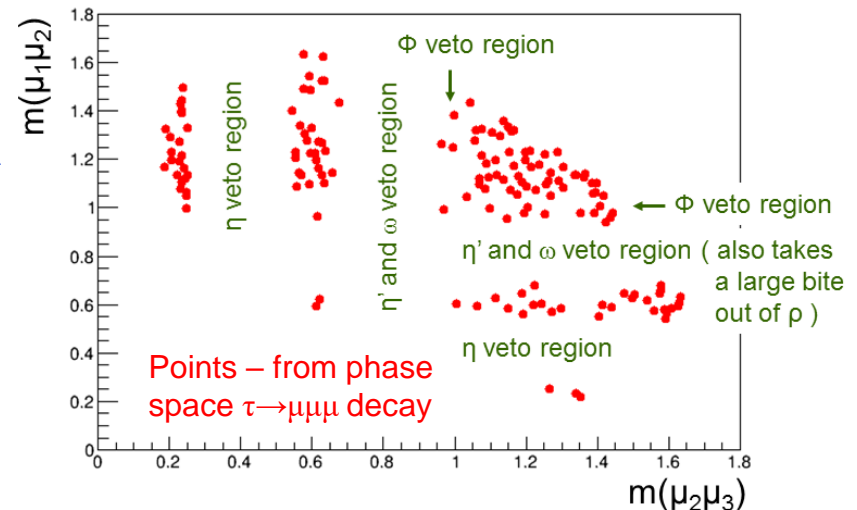

$\tau \rightarrow \mu\mu$: combatting charm backgrounds

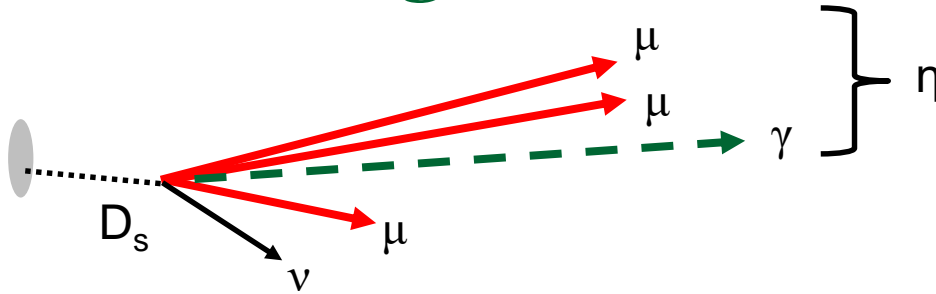

Mode	Relative abundance
$D_s \rightarrow \eta(\mu\mu)\mu\nu$	1
$D_s \rightarrow \phi(\mu\mu)\mu\nu$	0.87
$D_s \rightarrow \eta'(\mu\mu\gamma)\mu\nu$	0.13
$D \rightarrow \eta(\mu\mu\gamma)\mu\nu$	0.13
$D \rightarrow \omega(\mu\mu)\mu\nu$	0.06
$D \rightarrow \rho(\mu\mu)\mu\nu$	0.05

These backgrounds afflict $\tau \rightarrow \mu^+\mu^-\mu^-$ searches in hadronic environment (but are absent for modes such as $\tau \rightarrow \mu^+e^-e^-$). Various tools are available.

- Invariant mass of candidate
- Invariant mass of dimuon pairs
- Photon veto for η and η' modes
- Photon tag to select $D_s^* \rightarrow D_s(\rightarrow \tau\nu)\gamma$

Suppresses all non- D_s backgrounds; useful for combatting dangerous $D^+ \rightarrow \rho(\rightarrow \mu\mu)\mu\nu$ contamination.

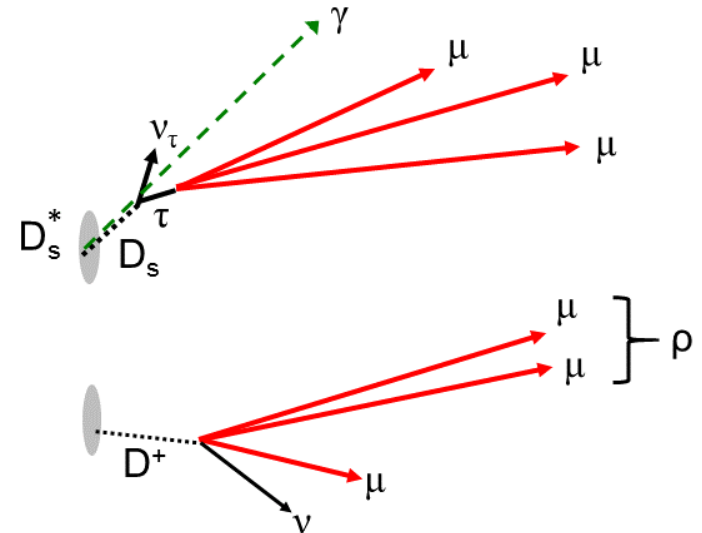

$\tau \rightarrow \mu\mu\mu$: combatting charm backgrounds

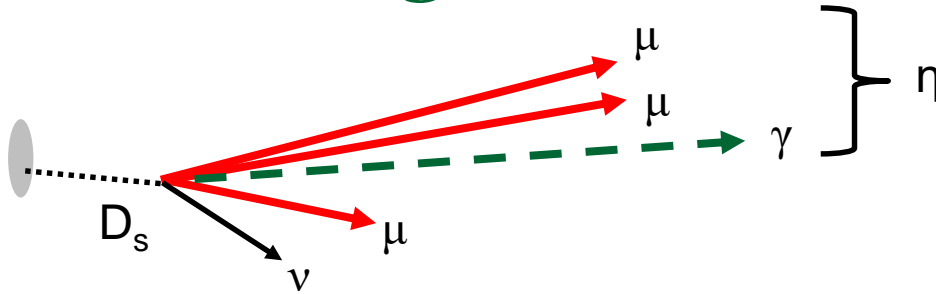

Mode	Relative abundance
$D_s \rightarrow \eta(\mu\mu\gamma)\mu\nu$	1
$D_s \rightarrow \phi(\mu\mu)\mu\nu$	0.87
$D_s \rightarrow \eta'(\mu\mu\gamma)\mu\nu$	0.13
$D \rightarrow \eta(\mu\mu\gamma)\mu\nu$	0.13
$D \rightarrow \omega(\mu\mu)\mu\nu$	0.06
$D \rightarrow \rho(\mu\mu)\mu\nu$	0.05

These backgrounds afflict $\tau \rightarrow \mu^+\mu^-\mu^-$ searches in hadronic environment (but are absent for modes such as $\tau \rightarrow \mu^+e^-e^-$). Various tools are available.

- Invariant mass of candidate
- Invariant mass of dimuon pairs
- Photon veto for η and η' modes
- Photon tag to select $D_s^* \rightarrow D_s(\rightarrow \tau\nu)\gamma$
- Kinematics relating interaction and decay vertices

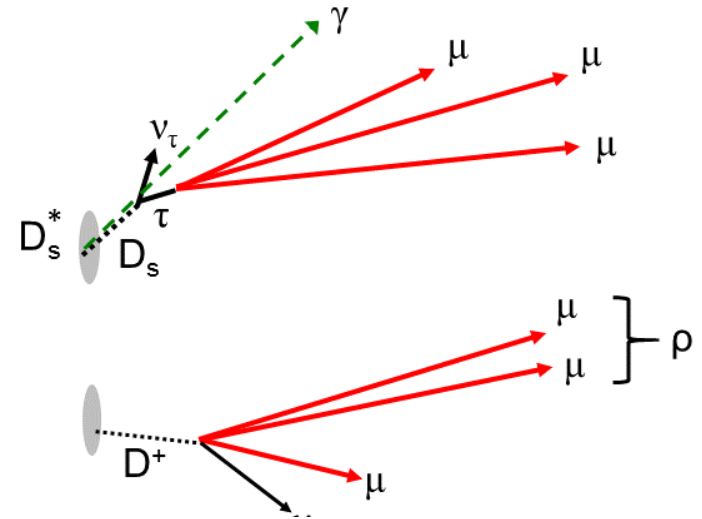

Cut-based studies in progress (full power will come from MVA approach), but we are confident that sensitivities to BRs of a few 10^{-10} are attainable.

Location, beam and environment studies

Several candidate locations have been identified in BDF, the most promising of which is around 100 m upstream of SHiP target bunker. This would provide adequate 'drift space' for experiment between beam line elements, and also appears suitable from point of view of shielding, access, services *etc.*

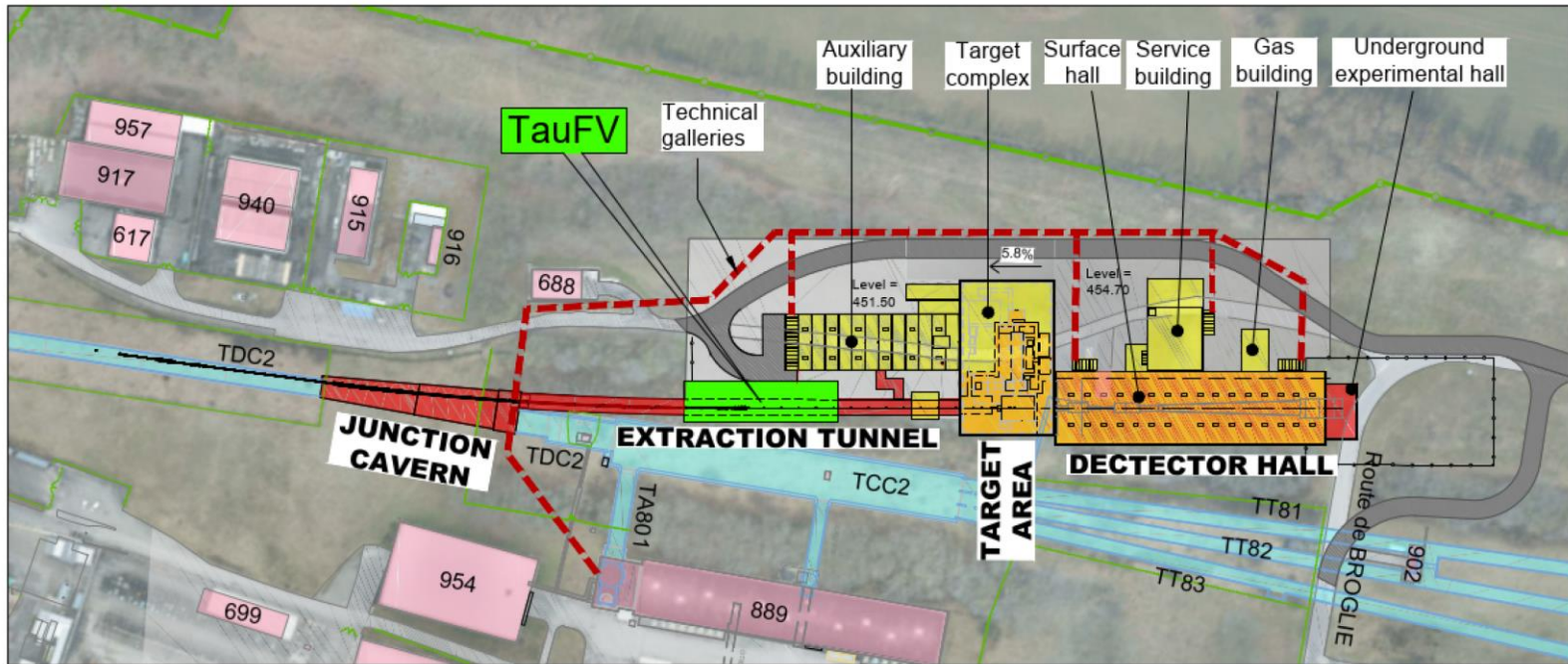

Location, beam and environment studies

Enormous effort from the BDF team and associated experts at CERN.
Preliminary studies on a wide range of issues. Those checked for far:

- TauFV dipole compatible with beam optics for SHiP (but compensator needed)
- ‘Squashed’ beam profile achievable
- Dipole polarity inversion possible (for systematic checks and CPV studies)
- Helium cooled target system looks feasible
- Radiation environment for beamline OK

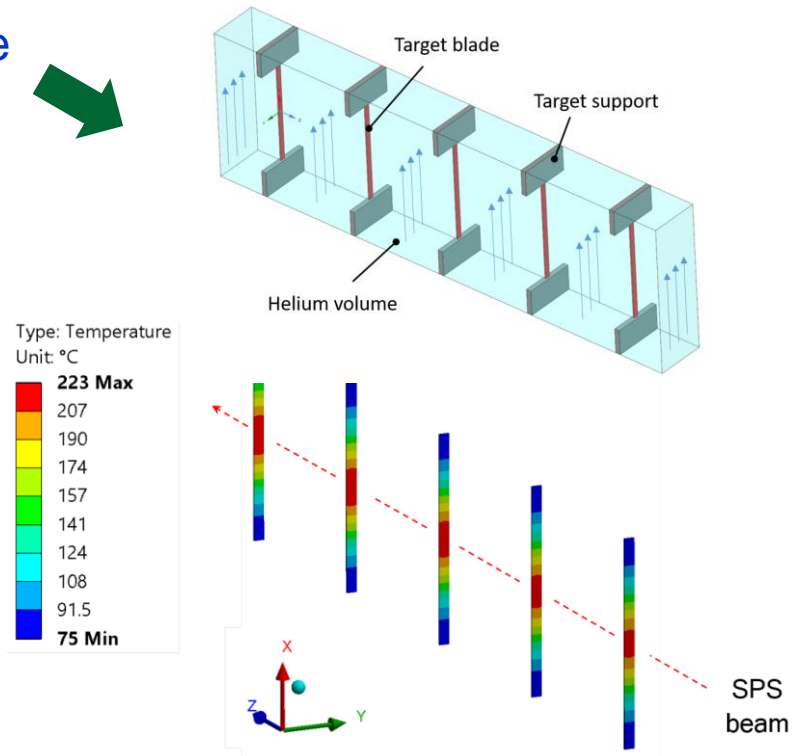
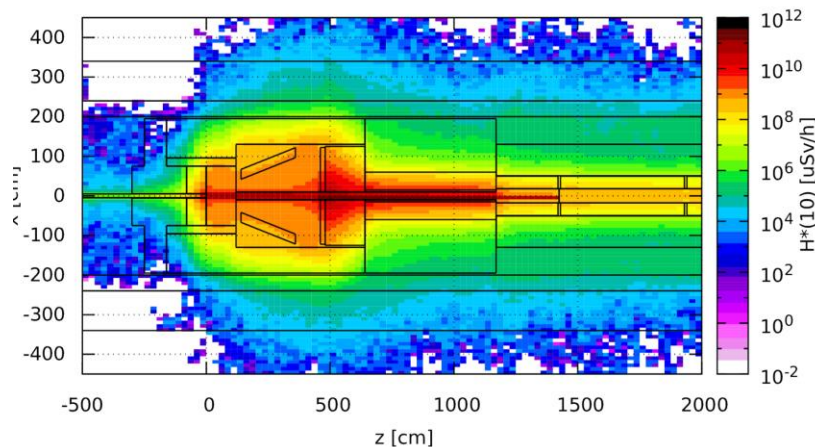

VELO stations

For each VELO station we intend to use modules constructed of hybrid pixel sensors, very similar in design to those being installed in LHCb Upgrade I.

Lightweight and compact, e.g. benefitting from state-of-the-art microchannel CO₂ cooling.

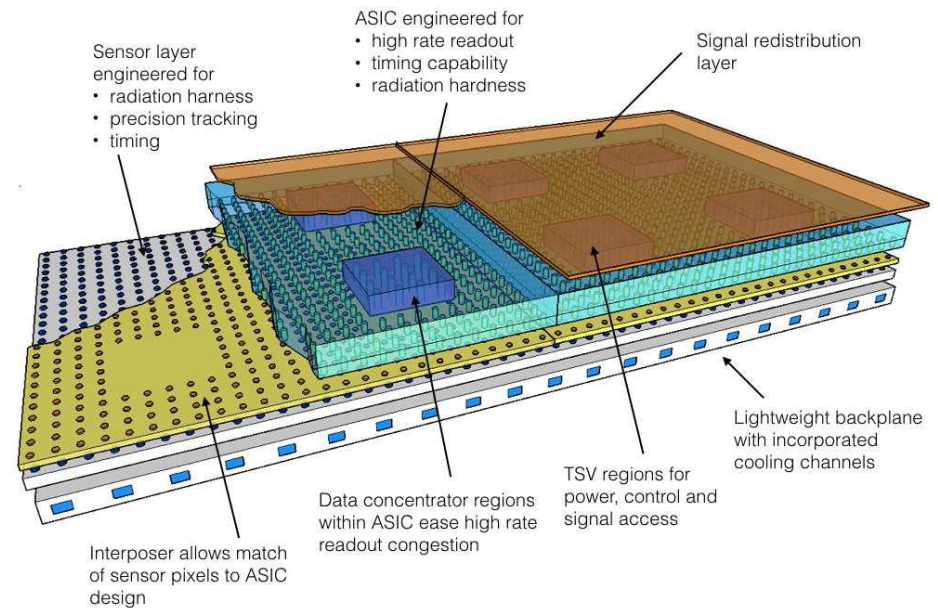
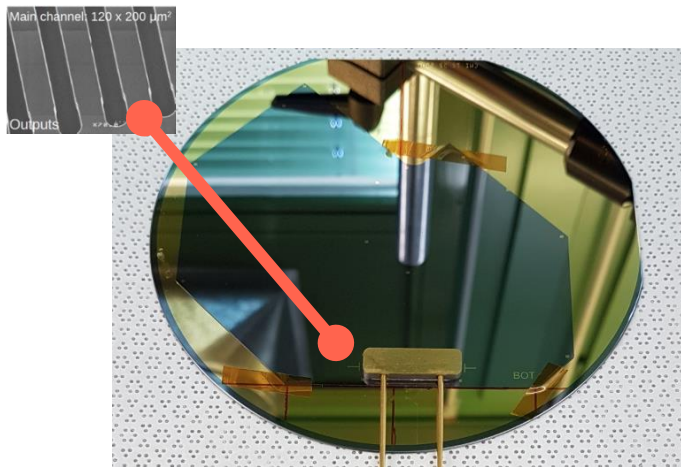

Innovations required for TauFV very similar to those required for LHCb Upgrade II. Aim for ~50 ps timing.

Sensor-cooler-ASIC assembly.

VELO ASIC

Thinking underway on requirements and possibility for frontend ASIC of VELO.

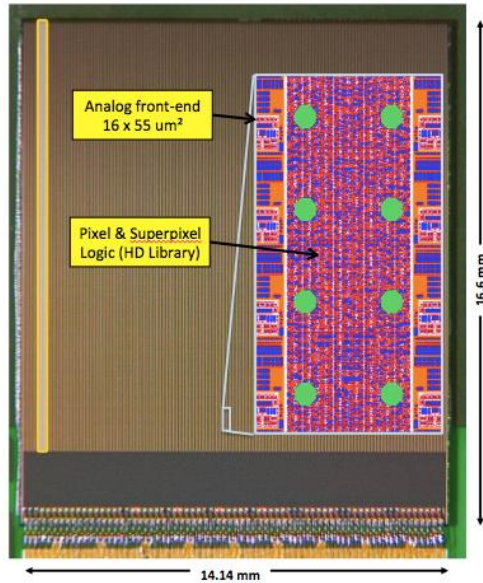

the VeloPix

	VeloPix (2016)	Timepix4 (2018/19)	PicoPix ? (2025)
Technology	130 nm	65 nm	28 nm
Pixel Size	55 x 55 μm	55 x 55 μm	55 x 55 μm
Pixel arrangement	3-side buttable 256 x 256	4-side buttable 512 x 448	4-side buttable 256 x 256
Sensitive area	1.98 cm^2	6.94 cm^2	1.98 cm^2
Event packet	24 bit	64-bit	32-bit
Max rate	~400 Mhits/ cm^2/s	178.8 Mhits/ cm^2/s	~12000 Mhits/ cm^2/s
Best time resolution	25 ns	~200ps	~50 ps
Readout bandwidth	19.2 Gb/s	81.92 Gb/s	~600 Gb/s

Fruitful collaboration with the Medipix group has yielded the VeloPix ASIC for the LHCb Upgrade I. A new generation chip, the Timepix4, with impressive fast timing capabilities is scheduled to appear soon. Our requirements are more demanding still – working title the ‘PicoPix’ (still at conceptual stage)

TORCH: Timing of Internally Reflected Cherenkov light

TORCH can provide ultra-precise time-of-flight measurements over large area. [NIM A639 (2011) 173, arXiv:1009.3793]. Attractive for fast-timing measurements and low-momentum particle identification. Under evaluation for future LHCb Upgrades.

Following on from an original ERC grant, R&D is continuing as standalone project involving CERN, Oxford, industry (PHOTEX), Bristol, Warwick, Edinburgh & Bath.

- Goal is to achieve 70 ps resolution per photon, which gives 10-15 ps per track.
- Demonstrator module has achieved ~80 ps [NIM A908 (2018) 256; arXiv:1805.04849].

A large-scale prototype now exists, which recently collected data in CERN beam test.

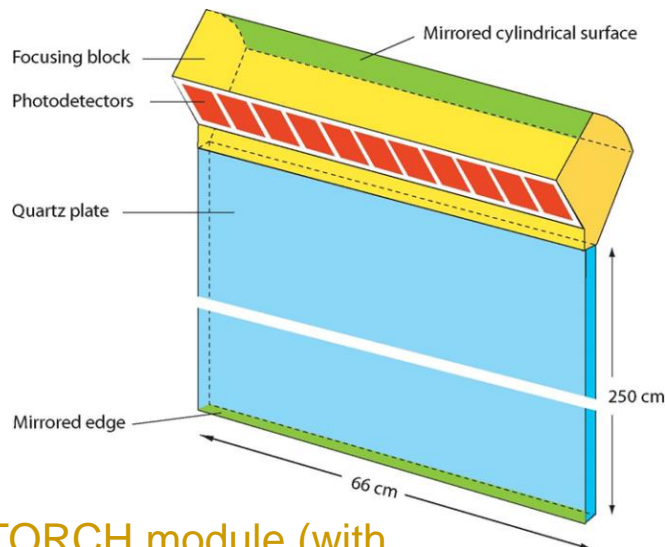

TORCH module (with LHCb-suitable dimensions)



Quartz plate for prototype at CERN (half height w.r.t. LHCb requirements)

TORCH: Timing of Internally Reflected Cherenkov light

TORCH a very attractive technology for TauFV:

- Fast timing will be invaluable in combinatoric suppression;
- Particle identification will enable charm physics CPV studies;
- Very compact and intrinsically radiation hard.

TORCH module of TauFV-suitable dimensions – identical to prototype !

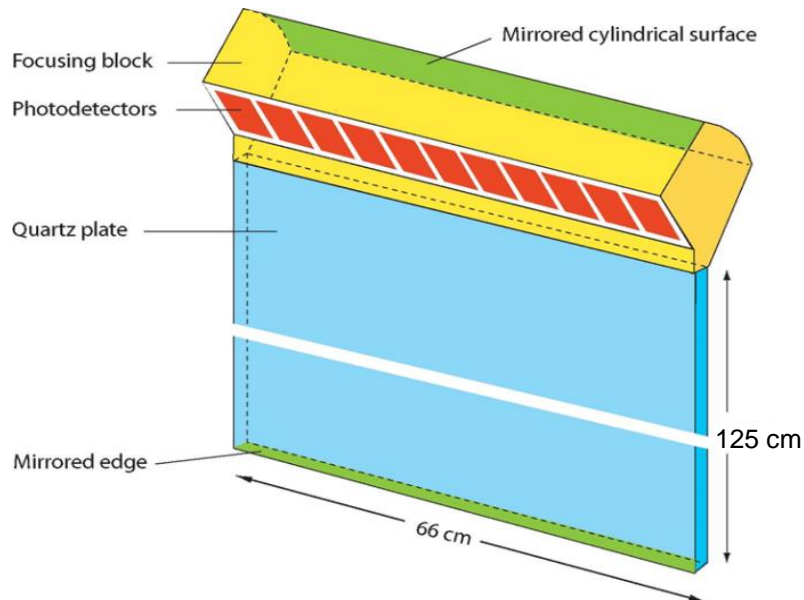

TORCH system in TauFV, comprising 10 modules

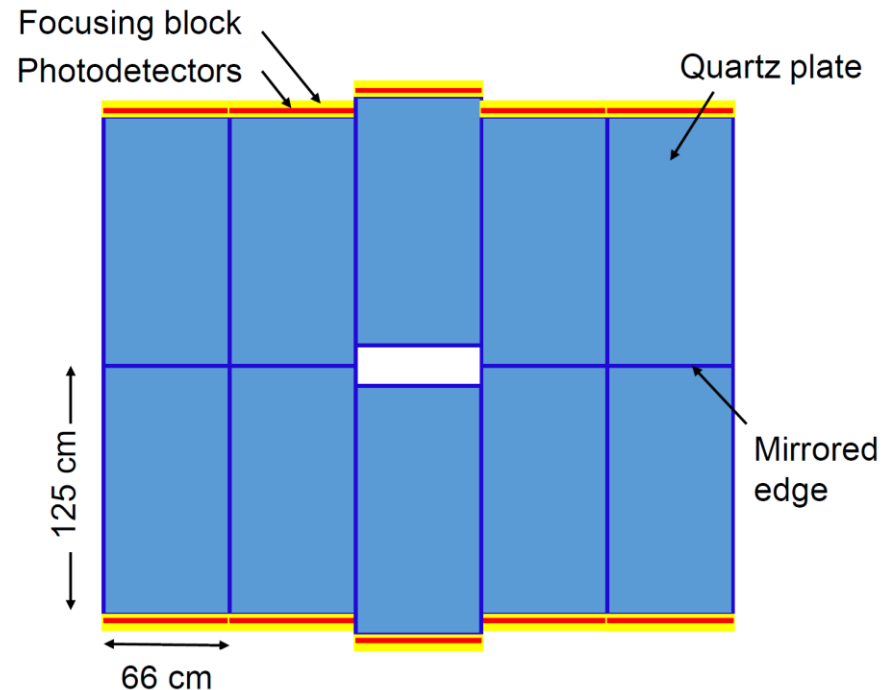

Calorimeter

Electromagnetic calorimeter will serve various purposes in experiment:

- Select forbidden tau and D decays with electrons;
- Tag $D_s^* \rightarrow D_s (\rightarrow \tau \nu) \gamma$ decays;
- Veto D & D_s decays with photons, e.g. $D_s \rightarrow \eta (\rightarrow \mu \mu \gamma) \mu \nu$;
- Select CPV and rare D decays involving photons, π^0 and η mesons.

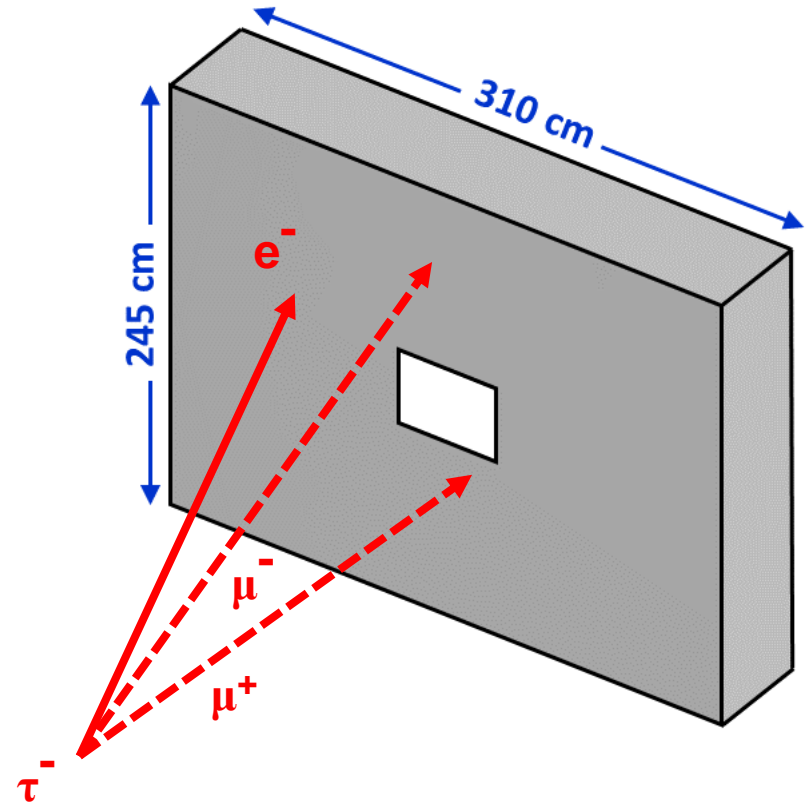

Studies are ongoing to establish precise requirements in terms of energy resolution, longitudinal shower sampling, and spatial and pointing resolution. Also require fast timing resolution (< 100 ps) & high radiation tolerance (> 100 Mrad).

Many of these goals are common with requirements of LHCb Upgrade II, and a common R&D programme is now underway.

Calorimeter: possible technologies

Homogenous crystal module (with longitudinal readout as an option)

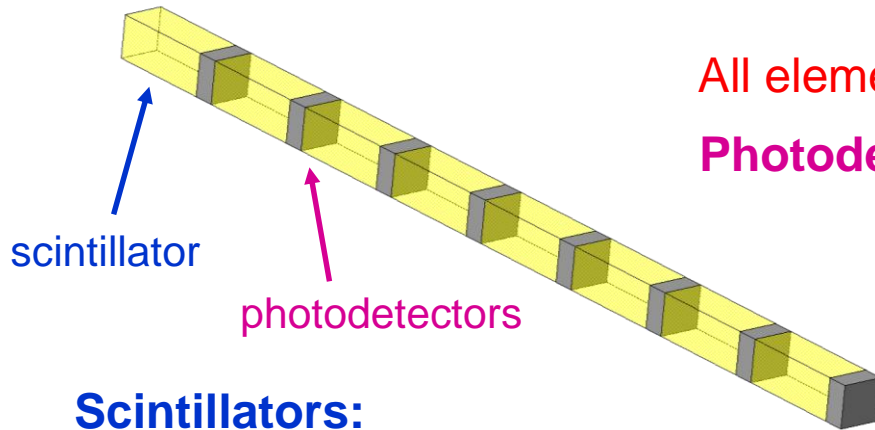

All elements must be very rad hard

Photodetectors: GaAs photo diodes may be a good option – under evaluation.

Scintillators:

Crystals with orthosilicate & garnet structure (e.g. YAG and GAGG) have high light yield. We are studying their radiation hardness and time response with different dopings.

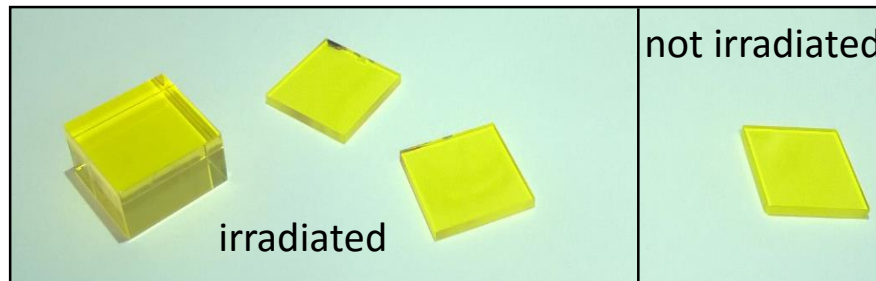

Study of transparency of 1 cm sample **before** and **after** ~100 Mrad irradiation.

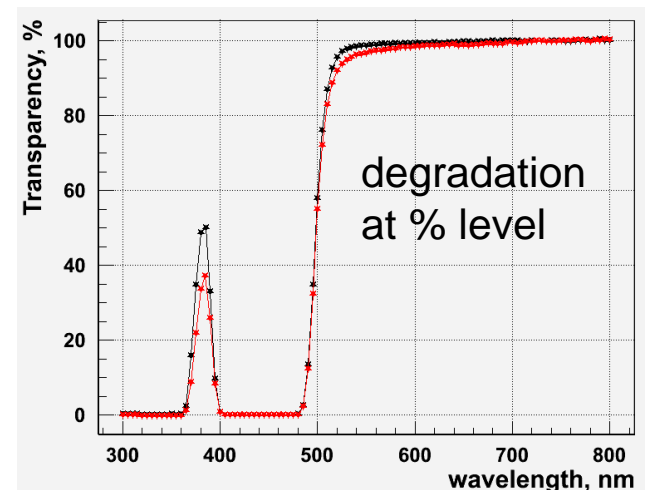

Calorimeter: possible technologies

Homogenous crystal module (with longitudinal readout as an option)

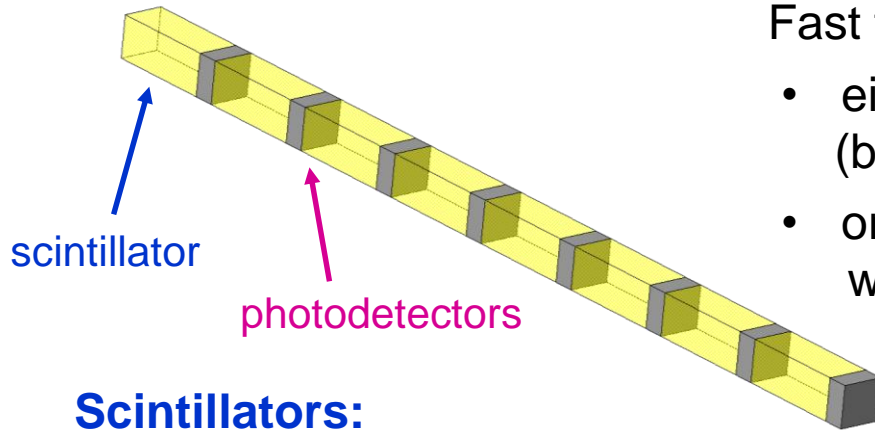

Fast timing to be provided by:

- either, leading edge of light pulse (beam tests underway)
- or, silicon pads in pre-shower detector, which would also yield precise pointing information (~mrad resolution helpful in bckgd rejection)

Scintillators:

Crystals with orthosilicate & garnet structure (e.g. YAG and GAGG) have high light yield. We are studying their radiation hardness and time response with different dopings.

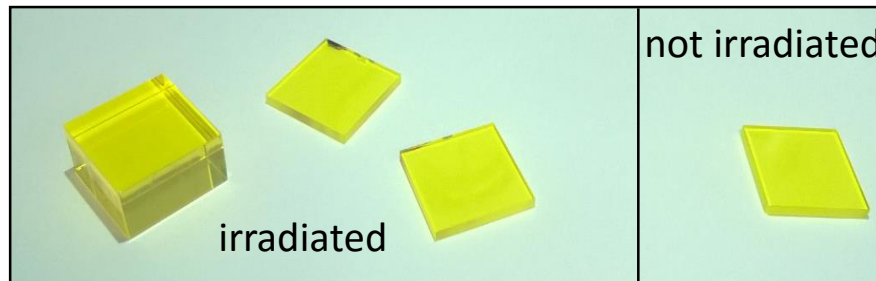

Study of transparency of 1 cm sample **before** and **after** ~100 Mrad irradiation.

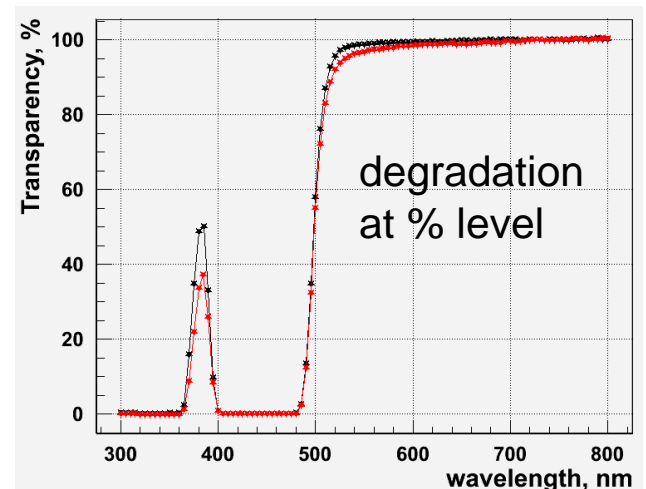

Calorimeter: possible technologies

Sampling calorimeter, e.g. SPACAL

- No need for WLS fibres, instead radiation hard GAGG fibre can both produce and transport the scintillation light.
- Tungsten or tungsten alloy absorber results in extremely compact shower – very well suited to high particle flux at TauFV.

Prototype module constructed and evaluated in beam test at CERN.

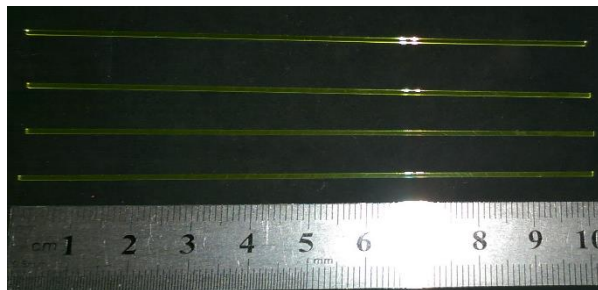

GAGG fibres

Analysis underway, but preliminary results indicate for energy resolution

a sampling term of $5-10\%/\sqrt{E}$ [GeV] is achievable, & time resolution of ~ 30 ps.

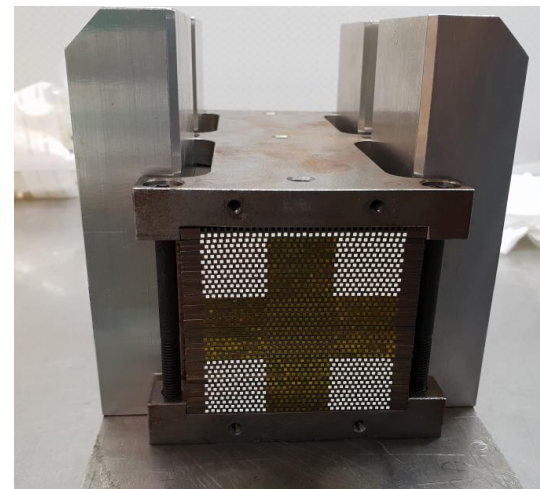

Prototype module containing cells made with variety of fibre materials, incld. GAGG.

Next steps and timeline

Document submitted to EPPSU. Other immediate tasks:

- Refine studies of background rejection in benchmark mode $\tau \rightarrow \mu\mu\mu$
- Extend studies to other physics modes of interest
- Define, more precisely, requirements of key detector elements

If all continues to look promising, seek additional collaborators and prepare Expression of Interest, whilst reiterating on simulation studies with additional realism, and continuing to pursue R&D of key detector elements.

When could TauFV be ready for data taking ?

- Schedule dictated both by construction of BDF, and development of challenging sub-detector technology, in particular the front-end ASICs.
- TauFV experimental hall call be prepared in 2026-27, in parallel with installation of SHiP. If progress is rapid, full detector could be deployed at this time. Alternatively install prototype experiment then, and proceed with full installation in LS4 (~2030).

Final remark: TauFV not limited by SPS intensity, & a future upgrade could operate at even higher rates. But this requires further improvements in detector technology.

Conclusions

- Development of BDF at SPS offers the opportunity to build a fixed-target experiment to search for LFV τ decays, which are long-acknowledged as a very sensitive probe for NP.
- Aim to exploit enormous τ production rate and dedicated design and to demonstrate sensitivity to benchmark $\tau \rightarrow \mu\mu\mu$ mode at the $O(10^{-10})$ level, which is a regime of particular interest due currently of particular interest.
- Even higher reach expected in other modes (e.g. $\tau \rightarrow \mu\mu e^+$), and also potential for world-leading studies in charm CPV and rare decays.
- Exciting challenges in detector technology, with great synergy with future collider experiment developments (e.g. fast timing & radiation hardness), in particular for VELO, TORCH and ECAL.
- Studies ongoing and submission to EPPSU is under preparation.
- We encourage anyone who is interested in contributing to come and talk to us !

Backups
