

# Conceptual Design of DUNE Near Detector Superconducting Magnet System

A. Bross, V. Kashikhin, D. Mitchell, C. Narug, T. Strauss, J. Theilacker, T. Tope, G. Velev

**Abstract**— The Deep Underground Neutrino Experiment (DUNE) has formed a near detector design group (NDDG) tasked with delivering a CDR by the end of 2019. The DUNE Near Detectors will be housed in an underground hall on the Fermilab site. The two main detector systems are a liquid argon detector and a high-pressure gas time projection chamber (HPgTPC). The HPgTPC requires a magnet that generates a 0.5 T solenoidal magnetic field in a large volume of 6 m diameter, and 5 m length. In this paper, we present a superconducting magnet system design. We investigated: an open air core magnet with three coils, and a five coils system having two active fringe field shielding coils. Coils positions were optimized to obtain the specified field homogeneity in the magnet good field region, while minimizing the Lorentz forces and the superconductor volume. We discuss the magnetic, mechanical, and thermal conceptual designs.

**Index Terms**—Superconducting magnet, magnetic field, NbTi superconductor, design, forces, stresses.

## I. INTRODUCTION

THE Deep Underground Neutrino Experiment (DUNE) will have the Near Detector (ND) complex underground on the Fermilab site. The magnet system of this detector needs to generate 0.5 T horizontal magnetic field in a large volume of 6 m diameter, and 5 m length. In this paper we present the magnet system conceptual design for the high-pressure gas TPC component of the DUNE near detector system with corresponding magnetic, mechanical, and thermal designs, which are strongly coupled. During this design study we investigated variants: a long solenoid with end shims and with or without an iron return, an open air core magnet with three coils, and a five coils system having three main coils and two active fringe-field shielding

coils. The five coils magnet system is currently the baseline version. The general view of superconducting magnet system shown in Fig. 1.

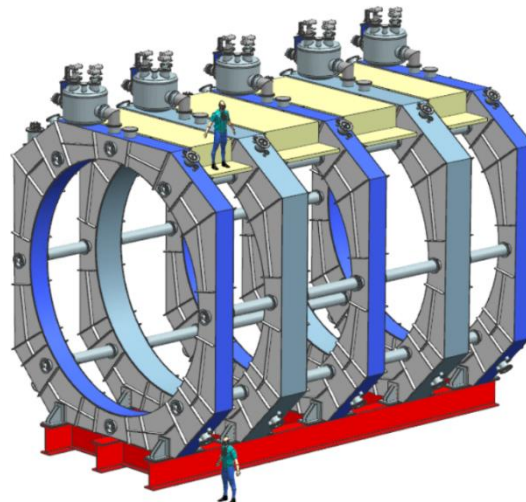

Fig. 1 HPgTPC detector magnet system overview.

One can see that the HPgTPC system has large dimensions, and parameters close to CMS [1], ATLAS [2], Mu2e [3], MPD [4] magnet systems. But the proposed configuration is rather novel for large detector magnets because instead of iron shielding, active fringe field shielding by superconducting coils is used. This approach is widely used in MRI solenoids, but those coils have a common cryostat for the main and shielding coils [5]. This approach, to active fringe field shielding instead of an iron yoke, substantially reduces the total magnet system weight and cost.

A. Bross is with Fermi National Accelerator Laboratory, Batavia, IL 60510 USA (e-mail: [bross@fnal.gov](mailto:bross@fnal.gov)).

Corr. author: V. Kashikhin is with Fermi National Accelerator Laboratory, Batavia, IL 60510 USA (e-mail: [kash@fnal.gov](mailto:kash@fnal.gov)).

D. Mitchell is with Fermi National Accelerator Laboratory, Batavia, IL 60510 USA (e-mail: [dmitchel@fnal.gov](mailto:dmitchel@fnal.gov)).

C. Narug is with Fermi National Accelerator Laboratory, Batavia, IL 60510 USA (e-mail: [cnarug@fnal.gov](mailto:cnarug@fnal.gov)).

T. Strauss is with Fermi National Accelerator Laboratory, Batavia, IL 60510 USA (e-mail: [strauss@fnal.gov](mailto:strauss@fnal.gov)).

J. Theilacker is with Fermi National Accelerator Laboratory, Batavia, IL 60510 USA (e-mail: [theilacker@fnal.gov](mailto:theilacker@fnal.gov)).

T. Tope is with Fermi National Accelerator Laboratory, Batavia, IL 60510 USA (e-mail: [tope@fnal.gov](mailto:tope@fnal.gov)).

G. Velev is with Fermi National Accelerator Laboratory, Batavia, IL 60510 USA (e-mail: [velev@fnal.gov](mailto:velev@fnal.gov)).

## II. MAGNET SYSTEM SPECIFICATION

The main magnet system specifications are shown in Table 1. These parameters were discussed at collaboration meetings and approved for the ND CDR.

TABLE I  
SPECIFIED PARAMETERS

Parameter	Units	Value
Magnetic field configuration		Axial-Symmetric
Center peak field	T	0.5
Good field area diameter/width	m	4/4
Field homogeneity	%	$\pm 10$
Clear bore diameter	m	7.0
Maximum outer diameter	m	9.0
Maximum length	m	12.0
Superconductor type		NbTi
Material for coils support structure and superconductor stabilizer		Aluminum
Coils operating temperature	K	$\leq 5$
Maximum coil deformation	mm/m	1.7
Maximum vacuum wall deformation	mm/m	2.0
Coils positional tolerance	mm	$\pm 5$
Admissible bucking limit	MPa	120
Cooling source		Cryoplant or Cryocoolers

It should be also noted that the underground cavern and its access shaft have limited dimensions which limits the size of objects that be utilized.

## III. MAGNETIC DESIGN

For the baseline HPgTPC magnet system, a conceptual design was chosen that uses five round coils configuration (See Fig. 2). This configuration has the following advantages:

- Low weight because of no iron yoke is used;
- Suppressed fringe fields because of shielding coils;
- Each pre-assembled coil inside the cryostat can be loaded through the shaft separately;
- Center and Sides coils are identical;
- All coils have the same inner and outer diameter which make their fabrication very efficient;
- All coils used the same superconducting cable carrying the same current.

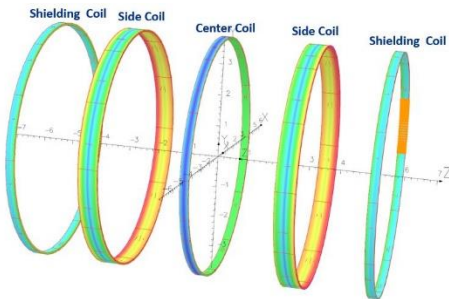

Fig. 2 The HPgTPC detector superconducting coils configuration.

This magnet system configuration generates an acceptable homogeneous magnet field in the bore (See Fig. 3).

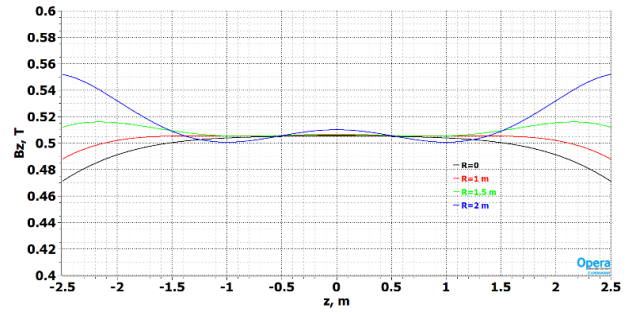

Fig. 3 Magnetic field in the magnet bore.

The magnet center field is 0.5 T at coil total currents: 1.08 MA (center and shield), 2.46 MA (side). The magnet system total stored energy is 109 MJ, and at 10 kA current the system inductance is 2.18 H. The coils are loaded by Lorentz forces in the radial direction, generating hoop stresses, and along the Z-axis (See Table 2). The total longitudinal force on all coils is equal to zero. The magnet coil parameters are shown in Table 2.

TABLE II  
MAGNET COILS PARAMETERS

Parameter	Units	Center coil	Side coil	Shield coil
Number of coils		1	2	2
Coil ampere-turns	MA	1.08	2.46	1.08
Coil peak field	T	2.53	3.32	2.72
Coil inner radius	m	3.8	3.8	3.8
Coil outer radius	m	3.862	3.862	3.862
Coil width along	m	0.27	0.616	0.27
Coil position in Z	m	0	3.0	5.5
Lorentz force in Z	MN	0	8.17	4.49

One of the critical issues for the magnetic design is the fringe field, which will be critical for the operation of electrical devices installed in the hall. To reduce the fringe field shielding coils (field clamps) were added. The radial space limits did not allow us to position these coils more effectively with larger radii. The fringe field map shown in Fig. 4.

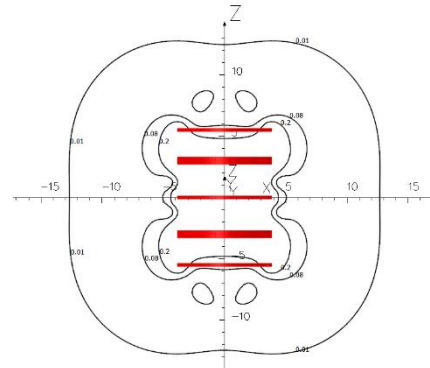

Fig. 4 Fringe field lines: 0.2 T (inner), 0.08 T (middle), 0.01 T (outer).

The maximum allowable 0.2 T fringe field for cryocoolers is inside the magnet system mechanical structures. The 0.08 T field line shows the boundary where ferromagnetic objects can

levitate into the solenoid under magnetic forces (“bullet” effect). Because the shielding coils have the same diameter as others, they are less efficient in suppressing the fringe field in the radial direction (only 1 m), and more efficient in z-direction (5 m). So, the three coils version might be viable after a more careful fringe field influence on the surrounding equipment analysis is performed.

Another critical issue is the quench protection for this 109 MJ stored energy system. We intend to use an active quench protection system where coil heaters are energized when the voltage rise is detected on voltage taps. The aluminum stabilized cables should be optimized, but for the conceptual design we choose two cables which were recently fabricated by Furukawa for Mu2e solenoids [3]. In these cables Rutherford type NbTi cable is imbedded inside a pure aluminum matrix. The Mu2e Production Solenoid [PS] and Detector Solenoid [DS] cable parameters shown in Table 3.

TABLE III  
SUPERCONDUCTOR PARAMETERS

Parameter	Units	PS	DS
Bare cable width	mm	30	20.1
Bare cable height	mm	5.5	7.0
Number of NbTi strands		30	12
Strand diameter	mm	1.44	1.3
Strand Cu/non-superconductor ratio		0.95	1.0
Critical current density at 4.2 K, 5 T	A/mm <sup>2</sup>	2750	2750
Aluminum RRR		600	1000
Copper RRR		80	80

The superconducting cables adiabatic heating shown in Fig. 5.

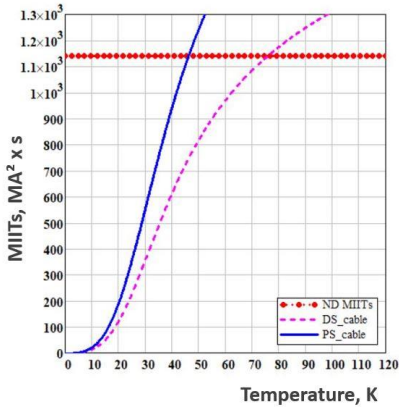

Fig. 5 Superconducting cables adiabatic heating during quench.

MIIT is an estimated time squared current integral for an exponential magnet discharge into an external 0.01  $\Omega$  dump resistor. Parameters of the DS cable are better suited to the magnet design, giving only 75 K of adiabatic cable heating. This is a very conservative estimation, which did not include the quench back effect from induced currents in the aluminum structures. These currents will heat the coils and accelerate the normal zone propagation in the superconducting cables. Some part of the stored energy will be dissipated in these aluminum parts.

It is critical for the magnet system design to predict possible failure scenarios. It is unlikely, but possible, that one of the coils

will short circuit or be unpowered when the others will have the full current. In this case, coil support structure must be capable of withstanding these unbalanced forces relative to the magnet system center. Table 3 shows the possible unbalanced Lorentz forces.

TABLE III  
MAGNET COILS PARAMETERS

Coil	Iw MA	Fz MN	Iw* MA	Fz* MN	Iw** MA	Fz** MN
Shield	1.08	-4.49	0	0	1.08	-0.65
Side	-2.46	8.17	-2.46	4.33	0	0
Center	-1.08	0	-1.08	-0.4	-1.08	2.91
Side	-2.46	-8.17	-2.46	-8.48	-2.46	-6.45
Shield	1.08	4.49	1.08	4.55	1.08	4.19

Iw – coil ampere-turns.

Fz – longitudinal Lorentz forces.

\* - one shield coil unpowered.

\*\* - one side coil unpowered.

One can see that the center coil in these scenarios must be capable of withstanding up to 3 MN of unbalanced force. This issue is resolved in the mechanical design with help of coil stoppers and the damping system.

#### IV. INTERACTION WITH OTHER SYSTEMS

Because underground cavern has very tight space constraints, the various systems can interact with each other. It is proposed to place the existing superconducting KLOE Magnet [6], shown in Fig. 6, close to the HPgTPC.

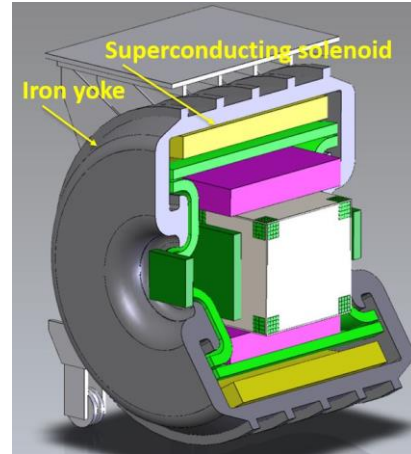

Fig. 6 KLOE superconducting magnet system.

A magnetic field analysis has shown a substantial coupling between the two magnets. The field was modeled when KLOE and the HPgTPC system were mounted at the distance of 12 m (between their centers) and have the same field direction (See Fig. 7). The KLOE solenoid total current is 2.17 MA to generate 0.6 T center magnetic field. At this current the iron yoke is saturated up to 2.03 T.

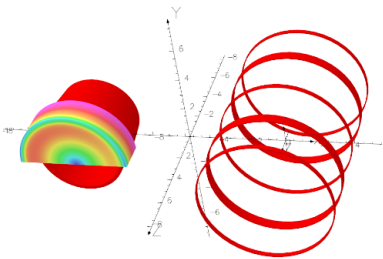

Fig. 7 KLOE Magnet (left), ND (right). For the KLOE magnet shown only  $\frac{1}{4}$  of the simplified iron yoke.

The magnetic force analysis showed rather large 0.18 MN residual force along x-axis applied to the HPgTPC magnet and KLOE iron yoke, and much lower 7.1 kN to the KLOE solenoid.

## V. MECHANICAL DESIGN

The magnet coil will be housed within a strongback designed to absorb the forces of the magnet and minimize flexure in the structure during operation. Each strongback will be held within a cryostat. The cross-sectional area of the strongback and coil can be seen in Fig. 8.

Due to the clearance available in the main shaft of the detector hall, each of the five coils in their cryostats will be brought down into the detector hall separately. Once in the hall, the strongback in their cryostats will be assembled together axially and connected using eight azimuthally distributed Invar rods to minimize the axial thermal contraction during the magnet's operation. To determine the initial sizing of the components, a series of line body simulations were performed using ANSYS Workbench 19.2. Using the Lorentz forces from the magnetic simulations, the dimensions of the strongback and the positions of the axial supports were determined. From an initial strongback design, the cross-sectional dimensions of the strongback were modified to create a structure that would have a deformation of less than 2mm, while minimizing the mass of the components that were used. The number of supports and the dimensions of the cross-sectional area were also varied to minimize the mass of the overall structure.

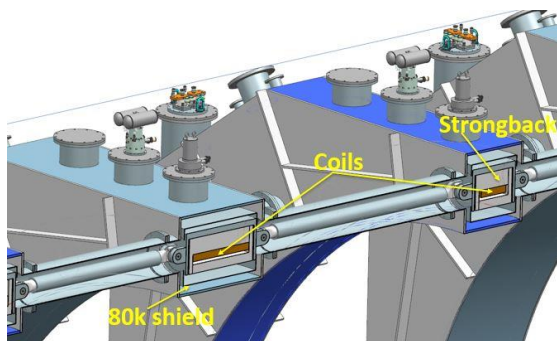

Fig. 8. Cross sectional view of coils assembly.

From this analysis, the cross section of all the supporting structure should have a height of approximately 300 mm and a

width of 400 mm for the center and shield strongbacks and a width of 720 mm for the side strongbacks. The total cold mass weight of the five coils is 43 tons. The maximum von Mises stresses in the cold mass were kept below 50 MPa.

## VI. THERMAL DESIGN

All five coils will have separate cryostats as shown in Fig. 8. The coil cold masses will be supported inside vacuum vessels by four thermal straps shown in Fig. 9. They must be capable of withstanding the cold mass weight and Lorentz forces from coils while having a low heat load to 4K.

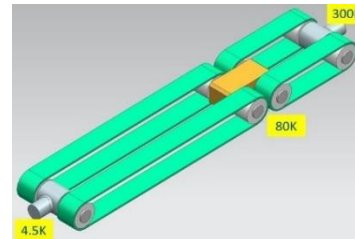

Fig. 9 Thermal straps supporting cold mass in the cryostat.

The calculated (ANSYS) heat load from four straps is estimated to be 0.2 W at 4.5 K. For the 80 K intercept, the heat load will be 3 W. So, the total heat load from all straps for the cryosystem will be 1 W for 4.5 K, and 15 W for 80 K levels correspondingly.

There are three cryogenic cooling options under consideration:

- Forced liquid helium [LHe] flow from a refrigerator;
- Thermosyphon cooling with cryoplant;
- Thermosyphon cooling with cryocoolers (See Fig. 10).

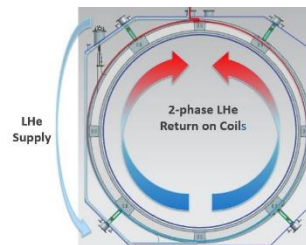

Fig. 10 Thermosyphon coil cooling.

A constraint is the crane height, which limits the total detector height. All these options are viable currently.

## VII. CONCLUSION

The DUNE HPgTPC magnet system conceptual design has confirmed the viability of the proposed magnet configuration. The preliminary magnetic, mechanical, and thermal analyses did not indicate any critical issues. The next step will be to perform more deep analyses for the Technical Design Report related to quench protection and possible field and force coupling to surrounding objects.

## REFERENCES

- [1] "CMS Magnet Project Technical Design Report", CERN/LHCC 97-10, CMS TDR 1, 2 May, 1997, pp. 292.
- [2] "ATLAS Magnet System Technical Design Report", CERN/LHCC 97-18, ATLAS TDR 6, 30 April, 1997, pp. 55.
- [3] "Mu2e Technical Design Report", Fermilab, October 2014, pp. 888.
- [4] "Multi-Purpose Detector. Solenoidal Magnet. Technical Design Report", NICA, JINR, August 2019, pp. 310.
- [5] I. J. Brown, *et al.*, "Magnet Assembly for Use in NMR Apparatus", US Patent 4,587,504, May 6, 1986.
- [6] K. D. Smith, *et al.*, "Progress in the Design and Manufacture of the KLOE Solenoid for the Daphne Ring at Frascati", IEEE Trans. Appl. Supercond., vol. 7, no. 2, June 1997, pp. 630 - 632.