

ITF Integration Sequence and Manpower

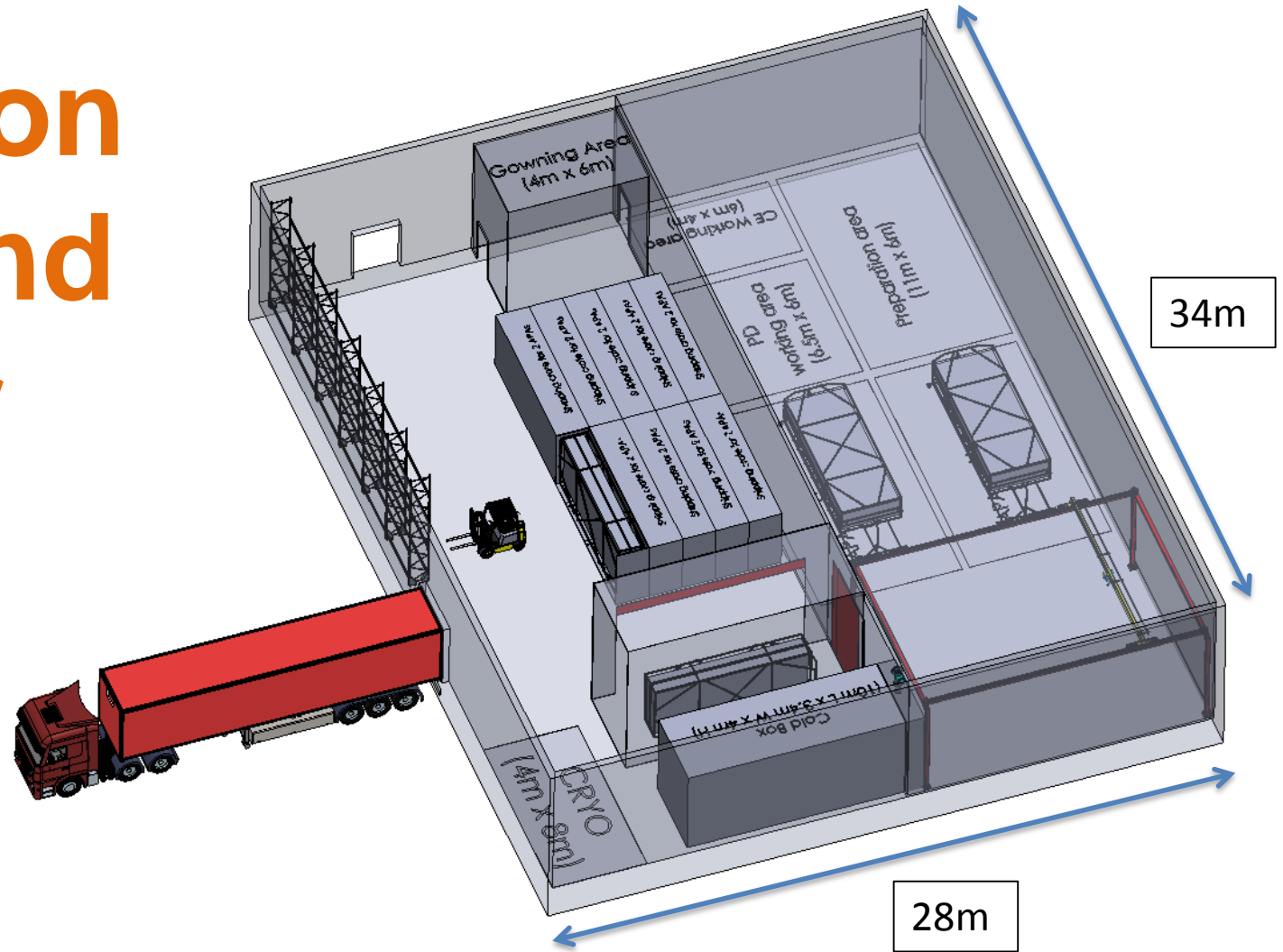

William Miller
University of Minnesota
24, January 2019v2

- 28m x 34m = 953m²
10,258 sq ft
- Needs to be optimized
- Needs Office space, building utilities/mechanical room and bathrooms added at Ash River this takes up ~8m x 18m



Schedule really needs space for 4 APA work areas to complete 2 sets of APA pairs per week. Add ~2000 sq ft?

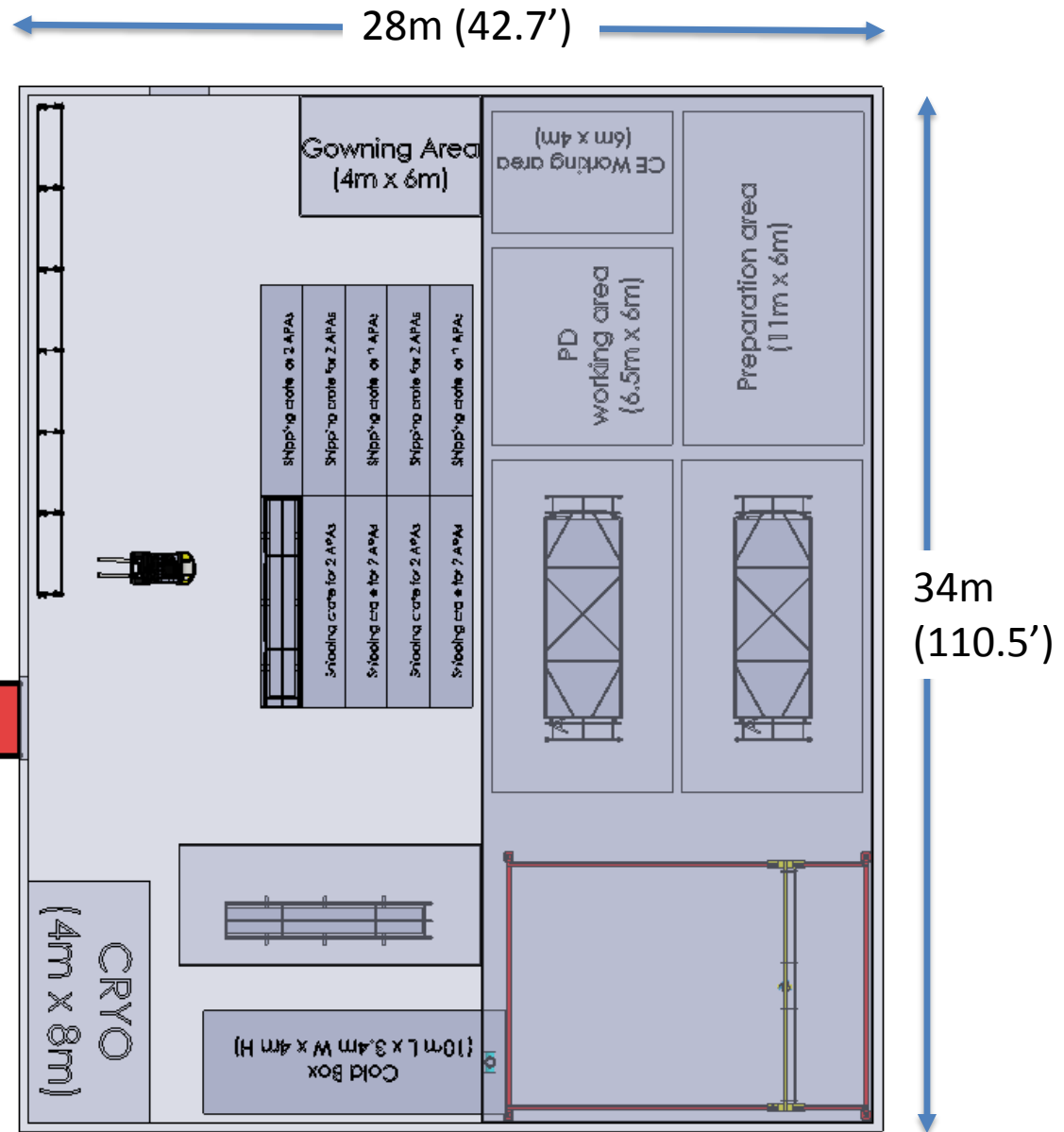

Simple overview of Concept

- Logistics Facility is where everything is stored long term, this helps minimize the size requirements on the ITF.
- ITF is basically just for APA integration
- Assume there is some infrastructure, commissioning and startup time- ~4-6 months with Cold Box and Cryogenics
- Integration Office supplies shared base labor for ITF and Logistics Facility to cover, management, safety, Admin support, inventory control, riggers and lead worker would supply labor for packing/repacking and moving material as needed, would be available to help as needed at all times.
- Consortia would supply labor for integration and testing

ITF and Logistics Facility	#FTE
Management	
ITF Scientific Lead	1.0
ITF Manager	0.5
ITF Supervisor	1.0
ITF Safety Officer	0.5
ITF Administrative Support	0.5
Labor Force	
Lead Worker	2
Riggers	4
Total	9.5

This is what is in current cost estimates

Baseline Assumptions

Assumptions

- 8 hour work days/5 days/week
- APAs are integrated and tested with all PDs and CEs but no permanent cables in ITF
- APAs will be moved from the shipping boxes to process carts and later moved to the final underground transport frame
- Installation of the photon detector bars in the APA slots will happen with the APA in the “flat” position.

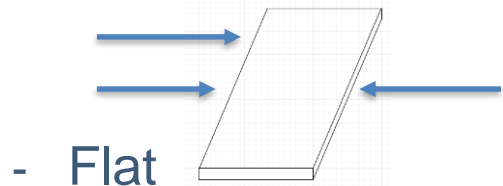

PD bars are slide into APA
PD Rails laying horizontally



Process Cart at PSL

Rough Labor Estimates-NOT optimized!

						Week 1									
						Monday		Tuesday		Wednesday		Thursday		Friday	
Task	#	APA	CE	PD	Rig	7:30	12:00	7:30	12:00	7:30	12:00	7:30	12:00	7:30	12:00
	Hours	# FTE	# FTE	# FTE	# FTE										
Loading Bay															
Receive and unload shipment	4	2			2	APA & Rig-1				APA & Rig-2					
Remove protective panels/outer frame	8	2			2	APA & Rig-1				APA & Rig-2					
Move into Airlock, remove plastic wrap	4	2			2	APA & Rig-1				APA & Rig-2					
Unload PD and CE boxes/week	4				2										
Replace protective panels/outer frame	8	2			2			APA & Rig						APA & Rig	
Place load on truck for shipment	4	2			2			APA & Rig						APA & Rig	
APA Cleanroom															
Place APA pair on 2 process carts	16	2			2			APA & Rig-1				APA & Rig-2			
Test Wire tension	32	2				APA-1				APA-2					
Install 40 FEMBs and perform tests	48		2			CE-1				CE-2					
Install 20 PDs-2 APA Pairs	16			2		PD-2						PD-1			
Test 20 PDs	16			2				PD-2						PD-1	
Place APA pair on shipping frame	8	2			2					APA & Rig-1				APA & Rig-2	
CE Testing Cleanroom															
Unpack, prep and test 40 FEMBs	48		2			CE Testing									
PD Testing Cleanroom															
Unpack, prep and test 20 PDs	16			2		PD				PD					
Total Hours and FTE Hours	232	168	192	96	110										
Total # FTEs		4.2	4.8	2.4	2.75										

Based on having 4 Process Carts
Needs ~6 shifts

APA shipping frames –CE Boxes – PD Boxes

- The APA pair arrives at the ITF in a shipping frame from UK or US via truck-Details to be worked out on bottom “Cart frame” but movable via fork truck
- The first step is to remove outside protective panels and side frames in loading dock area using fork lift then rolled into cleanroom airlock and cleaned before access into cleanroom
 - Interior APA has protective plastic coating
- CE boxes are shipped in crates and removed, placed on cleanroom cart in airlock for testing in cleanroom area.
- PDs arrive in crates and are removed and placed on rolling cart into Airlock

2-APA and 2-Riggers ~1 day total 4 FTE

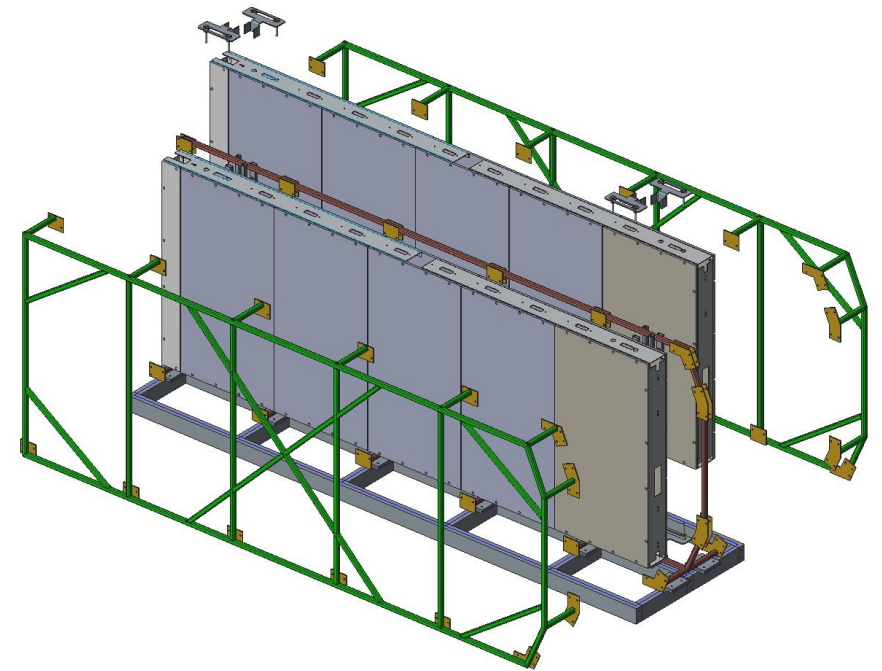

APA Shipping Frame cutout without outside protective panels-Peter Sutcliffe

Process Carts

- It appears from the pictures of the process cart from Daresbury that the CE conduit can not be installed while on the cart.
Better for PD repair if they are installed on APA Assembly Tower after test
- It takes 1 shift for two APA FTE and 2 riggers to take a pair of APAs off the shipping frame and move into the integration area
- It takes 1 shift for two APA FTE and 2 riggers to mount a pair of APAs back on the Underground shipping frame

2-APA and 2-Riggers ~2 days total 8 FTE



Daresbury Lab
Process Cart

APA Tension Measurements



- What is the tension measurement consist of for DUNE? Some combination of laser and plucking, plan is to make more automated.
- This needs to happen in landscape mode
- Time estimate is 2 shifts for wire tension measurements -

2-APA FTE ~2 days total 4 FTE

Install CE Boxes

- Estimate to unpack, prep and pre-test 40 FEMBs is ~3 shifts. This work is independent of the of the work on the APA pairs
- Estimate is 3 shifts to install and test 40 FEMBs on the APA pair in the horizontal position.
- A work platform at the proper height will to make this task ergonomically easier. It may also be beneficial to rotate the APA 180° if it makes access easier.

2-CE FTE ~3 days total 6 FTE-Testing Boxes

2-CE FTE ~3 days total 6 FTE-Installing

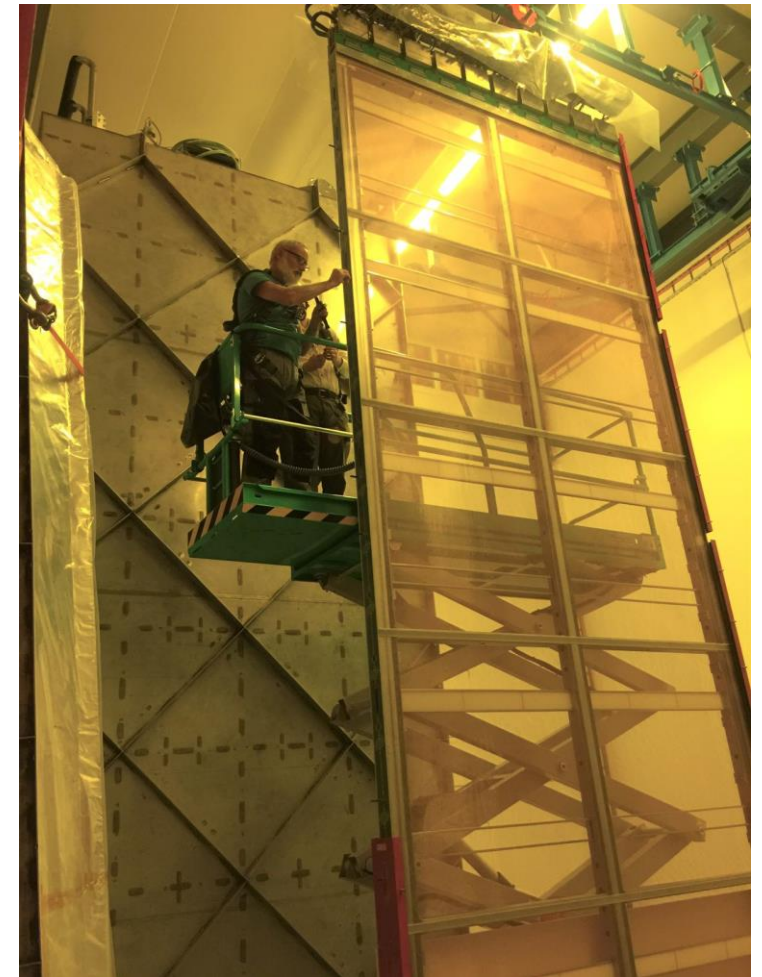

I was looking for a picture of CE boxes being installed but didn't find one. I did find Ken installing the Bo's HV FC wire. Is that part of the Bottom APA cable bundle?

Photon Detector Installation

- How much space is really needed for PD installation?
- Can we just work from one side at a time then move PD installation table?
- Is an 11m long x 6m wide area for each APA and process frame enough space to have PD insertion table and several FTE workers?
- Estimated time is one shift to install and one shift to test

Base Line Open questions to discuss

- We are starting to work on a real layout of the cleanroom for the ITF it is still at the conceptual level and appears that it fits with ~12,000sq and 4 process carts
- The ITF schedule needs to be adjusted in the overall schedule so we understand better when it is needed currently 12 months before the first APA goes into the Underground Cleanroom
 - APAs are clearly constructed first and need to be stored somewhere
 - Start of CE and PD integration is driven by their delivery schedule
 - Number of Process carts/work areas drive the schedule
- In the Ash River Trial assembly discussion we need to make sure that we are testing everything that we think is important. The integration of the shipping frame and process cart may be better
- How much time is needed for infrastructure and startup time in the ITF? I have 6 months maybe this is too conservative without the cold boxes now done at an APA Factory?

Backup Slides for APA Shipping Discussions

Base Line plan APA Shipping Frame and Process Cart for the TDR-

- In the Ash River Trial assembly discussion we need to make sure that we are testing everything that we think is important.
 - The integration of the shipping frame and process cart would better done at an APA Factory
 - The shipping frame to APA tower in a vertical position we can test at Ash River
 - 180° rotation of the box can be tested at AR
- Does the current design of the process cart allow us to use it with the conduit sticking out past the end of the side tube?
- What is the foot print of the process cart are we allowing enough room for movement in the ITF?
- I have written a shipping box requirements document-but it needs to be update.
- We need to think about the cost, how many boxes do we need, etc. When this was first proposed one of the complaints was the box was too expensive
- Are all boxes the same?

Modified Zimmer trucks for APA?

- Key point is that cable connection to the APA box is down from the top end as much as possible maximizing the length of the box.
- Bolts into the central APA frame structure
- Build in wheel system

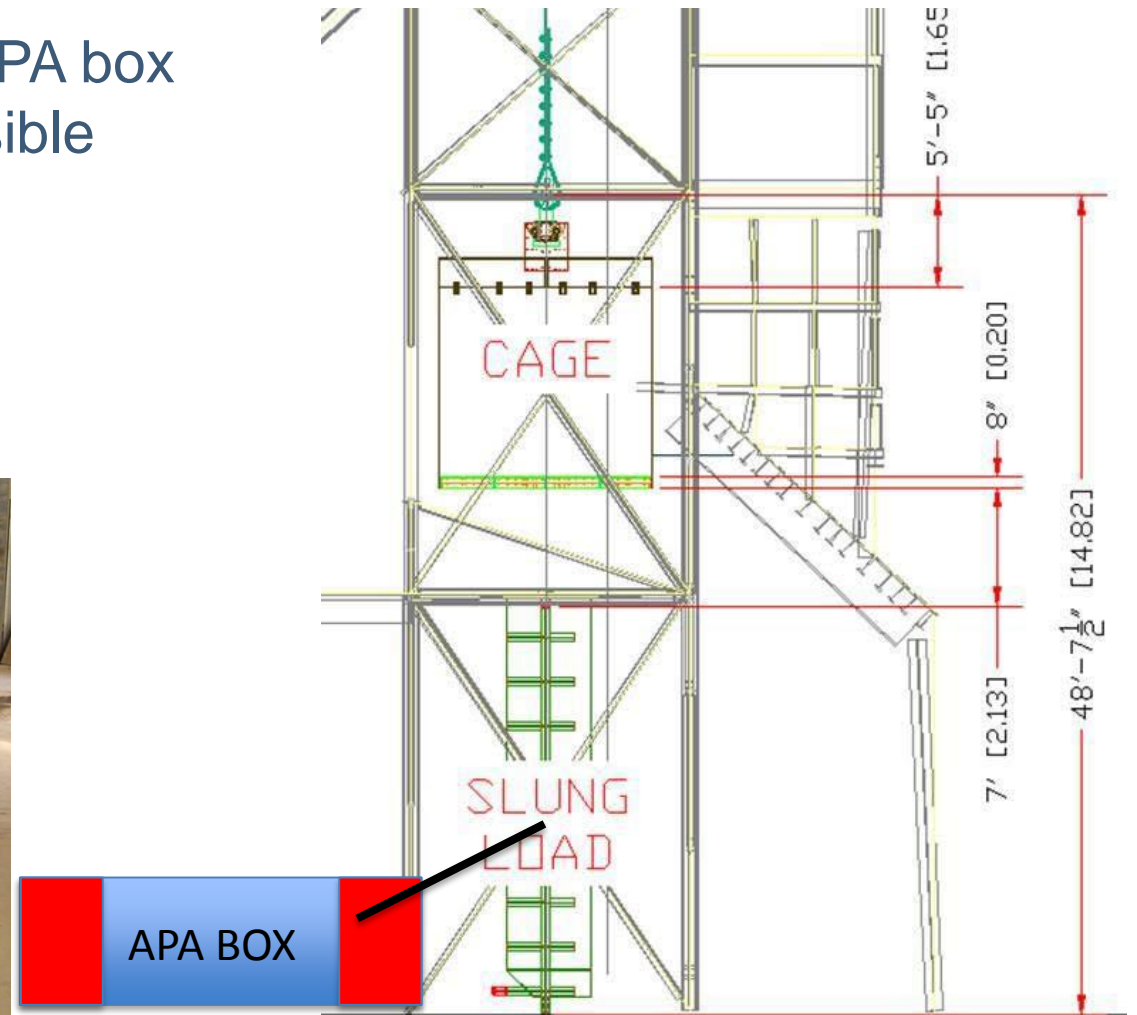

APA Shipping Frame

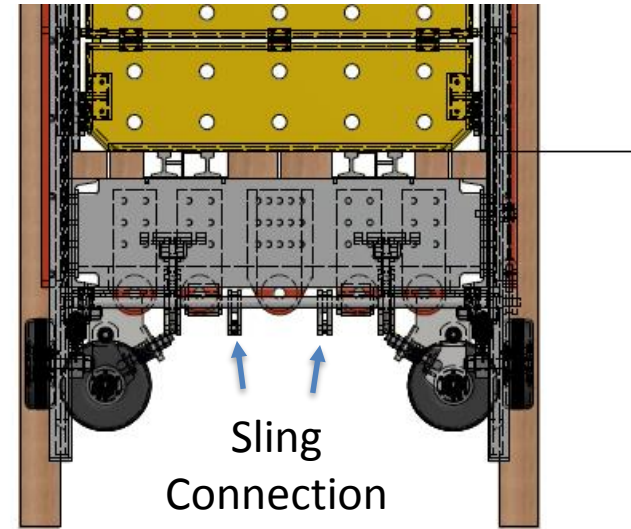
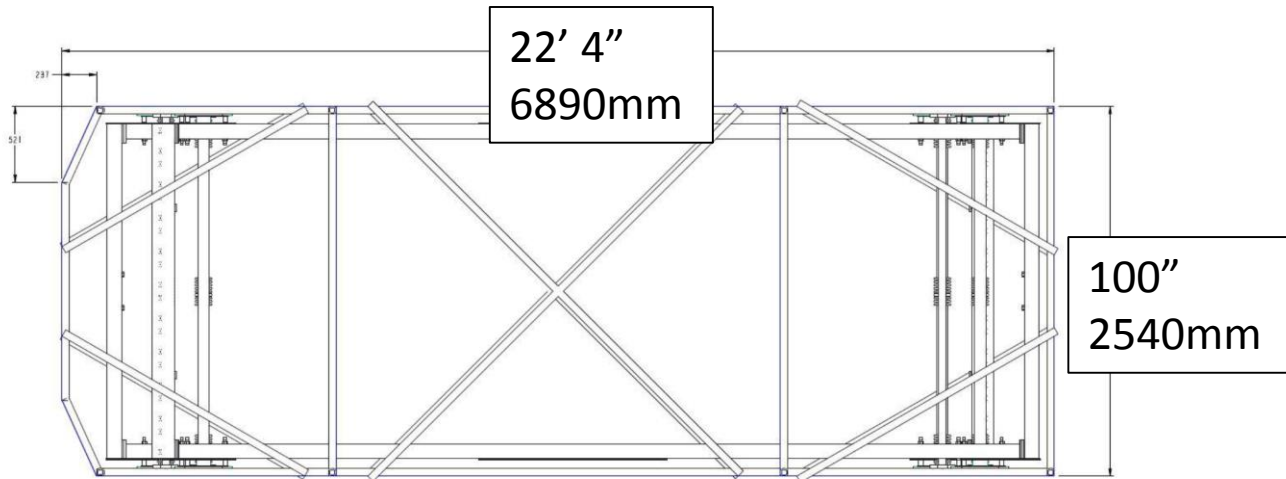
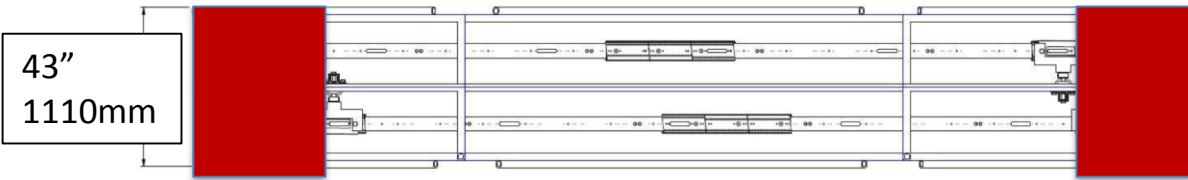

WEST END VIEW - LOOKING EAST

**This may solve the problem
in the shaft bit how do we
stand the box up in the
cleanroom?**