

# Measurement of Beam Current

The beam current is the basic quantity of the beam.

- It is the first check of the accelerator functionality
- It has to be determined in an absolute manner
- Important for transmission measurement and to prevent for beam losses.

**Different devices are used:**

- **Transformers:** Measurement of the beam's **magnetic field**

They are non-destructive. No dependence on beam energy

They have lower detection threshold.

- **Faraday cups:** Measurement of the beam's **electrical charges**

They are destructive. For low energies only

Low currents can be determined.

- **Particle detectors:** Measurement of the particle's **energy loss** in matter

Examples are scintillators, ionization chambers, secondary e<sup>-</sup> emission monitors

Used for low currents at high energies e.g. for slow extraction from a synchrotron.

**Generally:** Beam instruments are mounted outside of rf cavities to prevent for electro-magnetic interference from the high field; only inside cyclotrons some BI.

# Beam Structure of a pulsed LINAC

Pulsed LINACs and cyclotrons used for injection to synchrotrons with  $t_{pulse} \approx 100 \mu s$ :

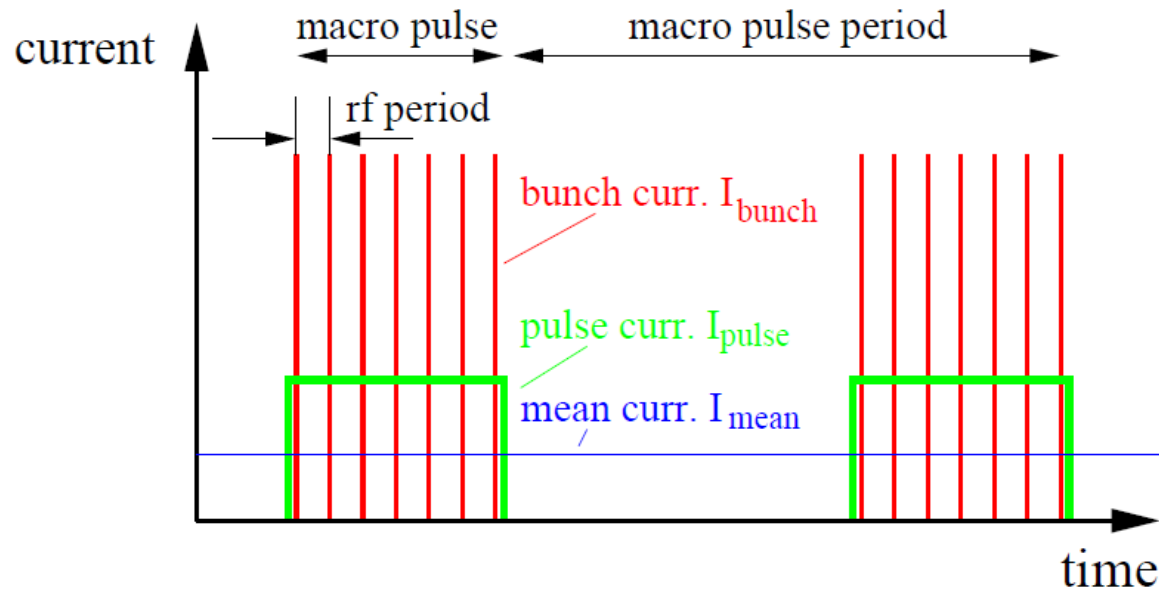

One distinguish between:

- Mean current  $I_{mean}$   
→ long time average in [A]
- Pulse current  $I_{pulse}$   
→ during the macro pulse in [A]
- Bunch current  $I_{bunch}$   
→ during the bunch in [C/bunch]  
or [particles/bunch]

**Remark:** Van-de-Graaff (ele-static):  
→ no bunch structure

# Magnetic field of the beam and the ideal Transformer

➤ Beam current of  $N_{part}$  charges with velocity  $\beta$

$$I_{beam} = qe \cdot \frac{N_{part}}{t} = qe \cdot \beta c \cdot \frac{N_{part}}{l}$$

➤ cylindrical symmetry

→ only azimuthal component

$$\vec{B} = \mu_0 \frac{I_{beam}}{2\pi r} \cdot \vec{e}_\varphi$$

Example:  $I = 1\mu\text{A}$ ,  $r = 10\text{cm} \Rightarrow B_{beam} = 2\text{pT}$ , earth  $B_{earth} = 50\mu\text{T}$

**Idea: Beam as primary winding and sense by sec. winding.**

⇒ Loaded current transformer

$$I_1/I_2 = N_2/N_1 \Rightarrow I_{sec} = 1/N \cdot I_{beam}$$

➤ Inductance of a torus of  $\mu_r$

$$L = \frac{\mu_0 \mu_r}{2\pi} \cdot l N^2 \cdot \ln \frac{r_{out}}{r_{in}}$$

➤ Goal of torus: Large inductance  $L$  and guiding of field lines.

Definition:  $U = L \cdot dI/dt$

magnetic field B

at radius r:

$$B \sim 1/r$$

$$\vec{B} \parallel \vec{e}_\varphi$$

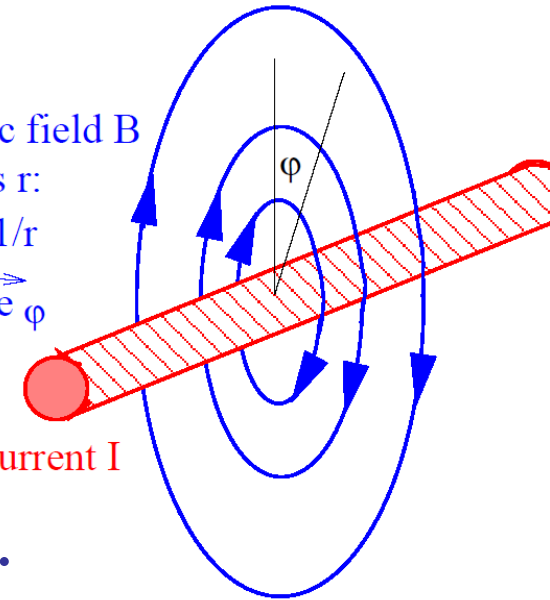

beam current I

Torus to guide the magnetic field

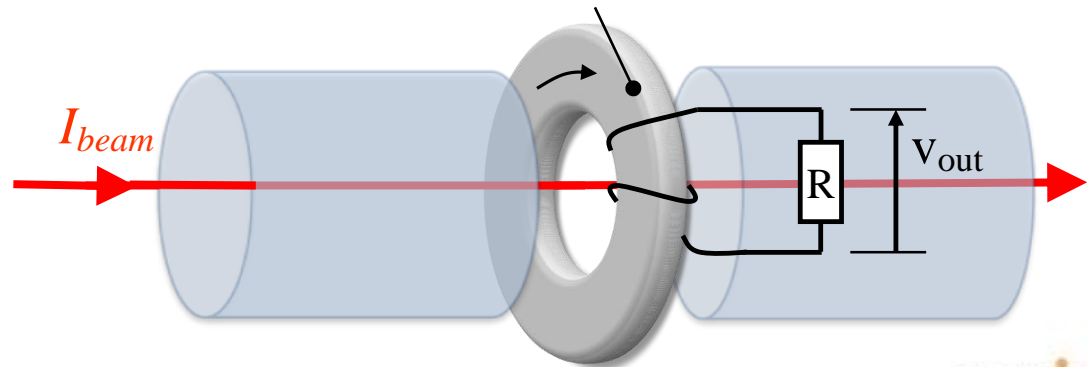

# Passive Transformer (or Fast Current Transformer FCT)

Simplified electrical circuit of a passively loaded transformer:

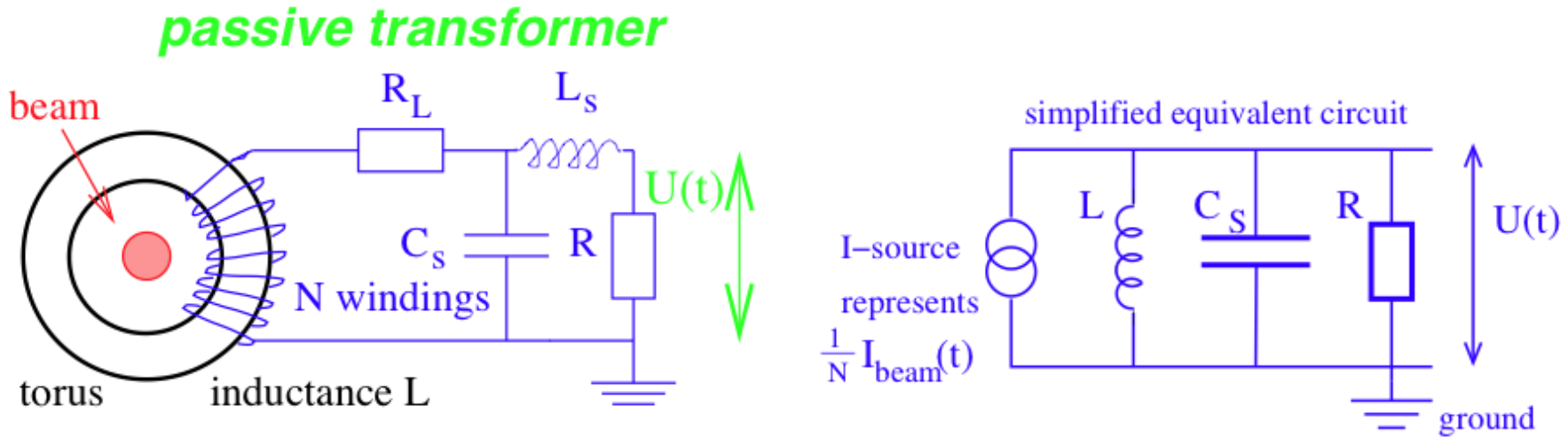

A voltages is measured:  $U = R \cdot I_{sec} = R / N \cdot I_{beam} \equiv S \cdot I_{beam}$

with  $S$  sensitivity [V/A], equivalent to transfer function or transfer impedance  $Z$

Equivalent circuit for analysis of sensitivity and bandwidth

(disregarding the loss resistivity  $R_L$ )

# Bandwidth of a Passive Transformer

## Analysis of a simplified electrical circuit of a passively loaded transformer: *passive transformer*

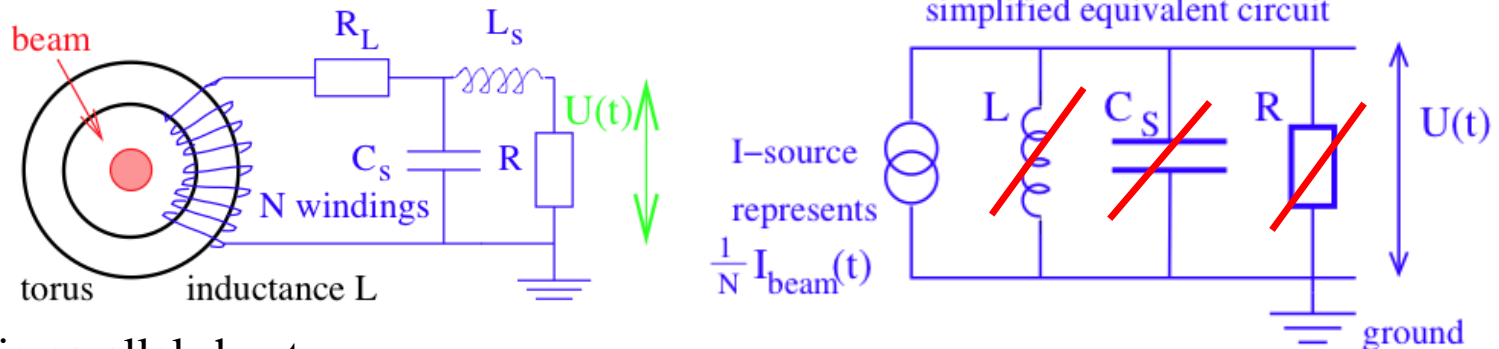

For this parallel shunt:

$$\frac{1}{Z} = \frac{1}{i\omega L} + \frac{1}{R} + i\omega C_S \Leftrightarrow Z = \frac{i\omega L}{1 + i\omega L/R - \omega L/R \cdot \omega R C_S}$$

➤ **Low frequency**  $\omega \ll R/L$  :  $Z \rightarrow i\omega L$

i.e. no dc-transformation

➤ **High frequency**  $\omega \gg 1/RC_S$  :  $Z \rightarrow 1/i\omega C_S$

i.e. current flow through  $C_S$

➤ **Working region**  $R/L < \omega < 1/RC_S$  :  $Z \simeq R$

i.e. voltage drop at R and sensitivity  $S=R/N$ .

No oscillations due to over-damping by low  $R = 50 \Omega$  to ground.

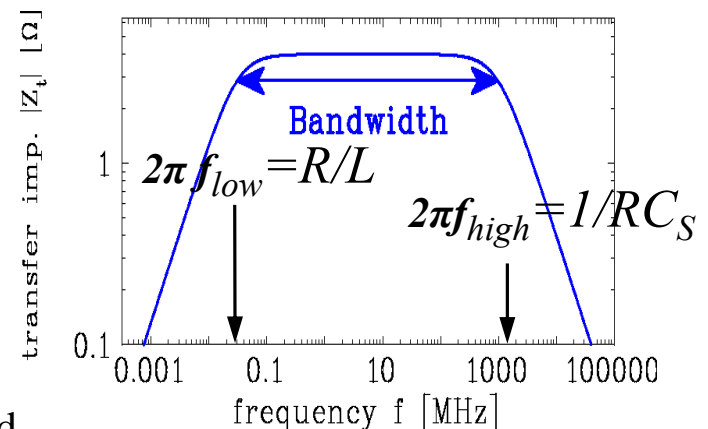

# Response of the Passive Transformer: Rise and Droop Time

## Time domain description:

Droop time:  $\tau_{droop} = 1/(2\pi f_{low}) = L/R$

Rise time:  $\tau_{rise} = 1/(2\pi f_{high}) = 1/RC_S$  (ideal without cables)

Rise time:  $\tau_{rise} = 1/(2\pi f_{high}) = \sqrt{L_S C_S}$  (with cables)

$R_L$ : loss resistivity,  $R$ : for measuring.

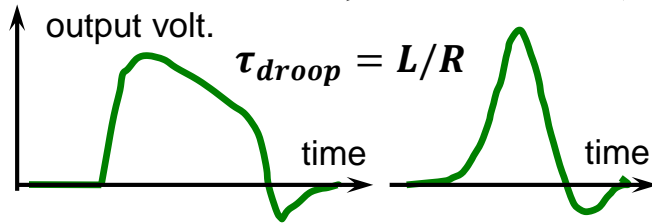
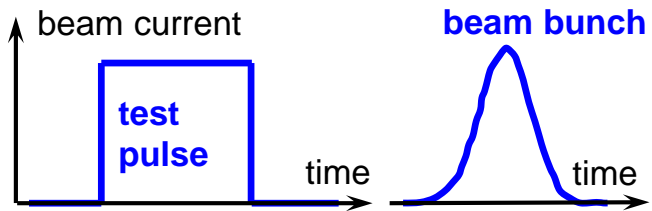
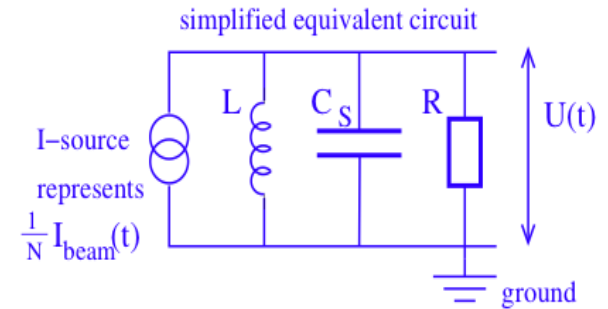

$$\tau_{rise} = \sqrt{L \cdot C_S}$$

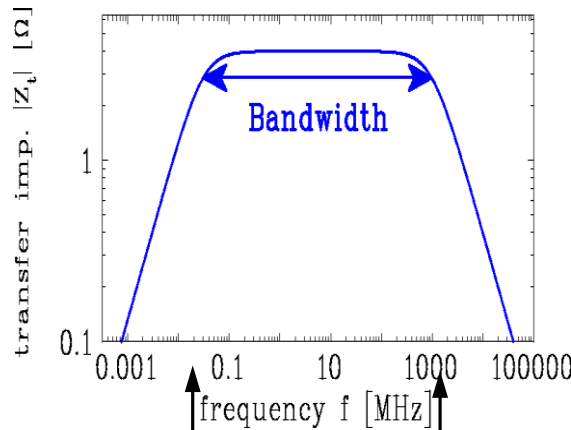

$$2\pi f_{low} = R/L$$

$$2\pi f_{high} = 1/RC_S$$

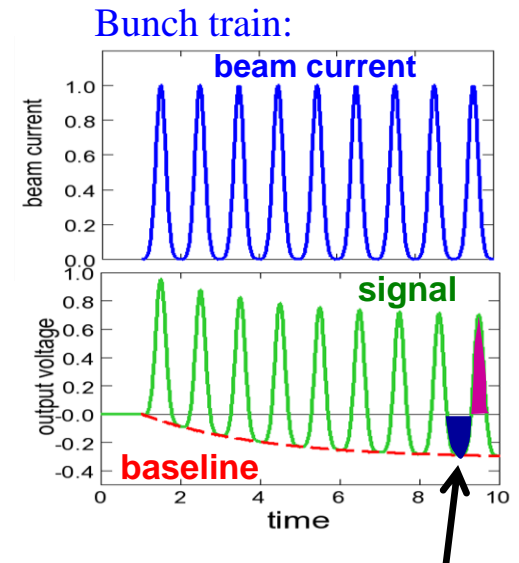

Baseline:  $U_{base} \propto 1 - \exp(-t/\tau_{droop})$   
 positive & negative areas are equal

# Example for Fast Current Transformer

From  
Company Bergoz



For bunch beams e.g. transfer between synchrotrons  
typical bandwidth of  $2 \text{ kHz} < f < 1 \text{ GHz}$   
 $\Leftrightarrow 1 \text{ ns} < t_{\text{batch}} < 200 \mu\text{s}$  is well suited

Example GSI type:

Inner / outer radius	70 / 90 mm
Permeability	$\mu_r \approx 10^5$ for $f < 100\text{kHz}$ $\mu_r \propto 1/f$ above
Windings	10
Sensitivity	4 V/A for $R = 50 \Omega$
Droop time $\tau_{\text{droop}} = L/R$	0.2 ms
Rise time $\tau_{\text{rise}} = \sqrt{L_S C_S}$	1 ns
Bandwidth	2 kHz ... 500 MHz

Fast extraction from GSI synchrotron:

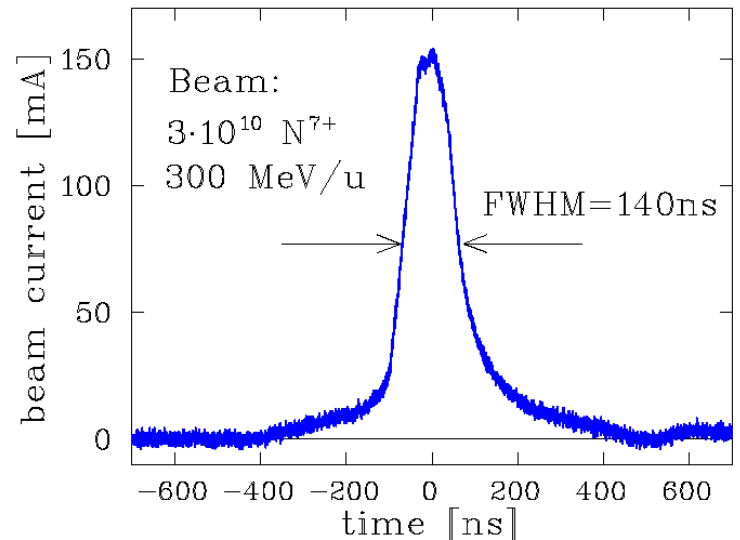

Numerous application e.g.:

- Transmission optimization
- Bunch shape measurement
- Input for synchronization of 'beam phase'

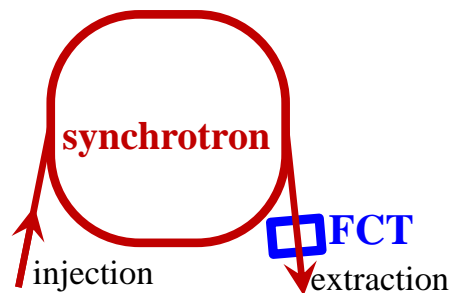

# Example for Fast Current Transformer

From  
Company Bergoz



Ø 200 mm

For bunch beams e.g. during accel. in a synchrotron  
typical bandwidth of  $2 \text{ kHz} < f < 1 \text{ GHz}$

$\Leftrightarrow 10 \text{ ns} < t_{\text{bunch}} < 1 \text{ } \mu\text{s}$  is well suited

Example GSI type:

Inner / outer radius	70 / 90 mm
Permeability	$\mu_r \approx 10^5$ for $f < 100\text{kHz}$ $\mu_r \propto 1/f$ above
Windings	10
Sensitivity	4 V/A for $R = 50 \text{ } \Omega$
Droop time $\tau_{\text{droop}} = L/R$	0.2 ms
Rise time $\tau_{\text{rise}} = \sqrt{L_S C_S}$	1 ns
Bandwidth	2 kHz ... 500 MHz

Example:  $U^{73+}$  from 11 MeV/u ( $\beta = 15 \%$ ) to 350 MeV/u  
within 300 ms (displayed every 0.15 ms)

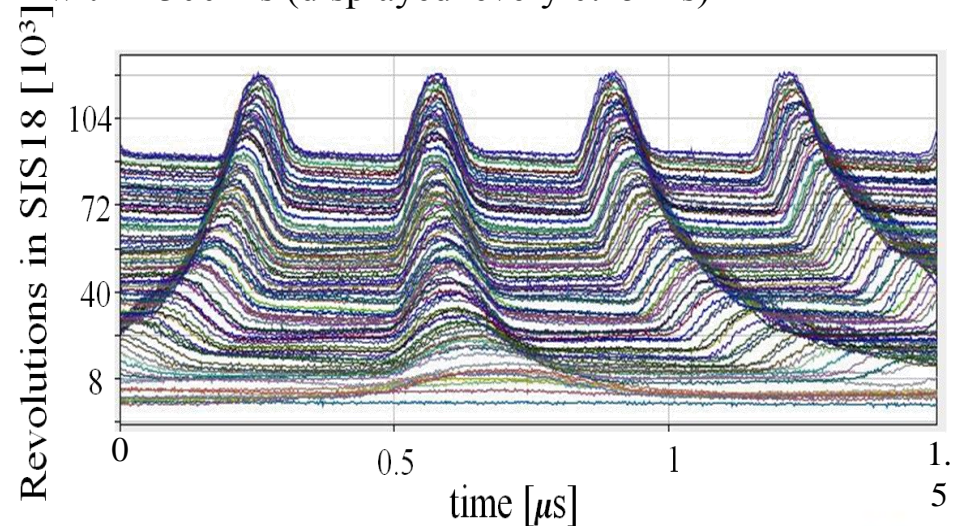
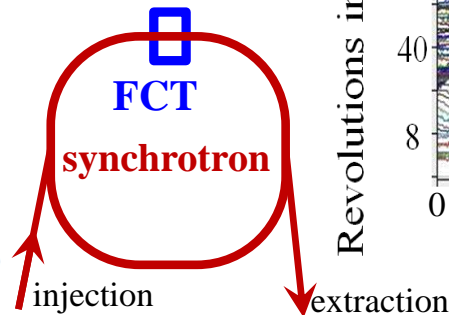
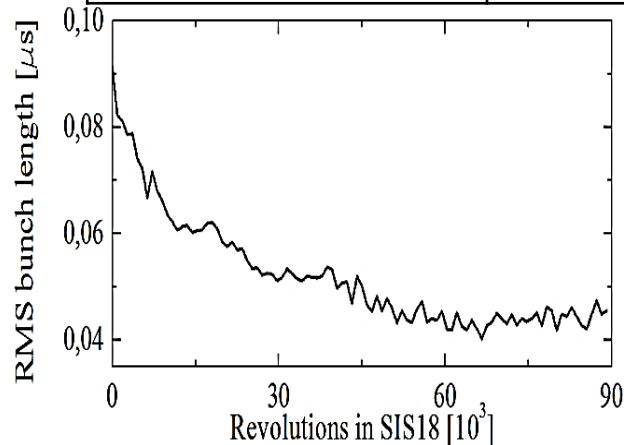



# 'Active' Transformer with longer Droop Time

## Active Transformer or Alternating Current Transformer ACT:

uses a trans-impedance amplifier (I/U converter) to  $R \approx 0 \Omega$  load impedance i.e. a current sink  
 + compensation feedback  
 $\Rightarrow$  longer droop time  $\tau_{droop}$

Application: measurement of longer  $t > 10 \mu s$  e.g. at pulsed LINACs

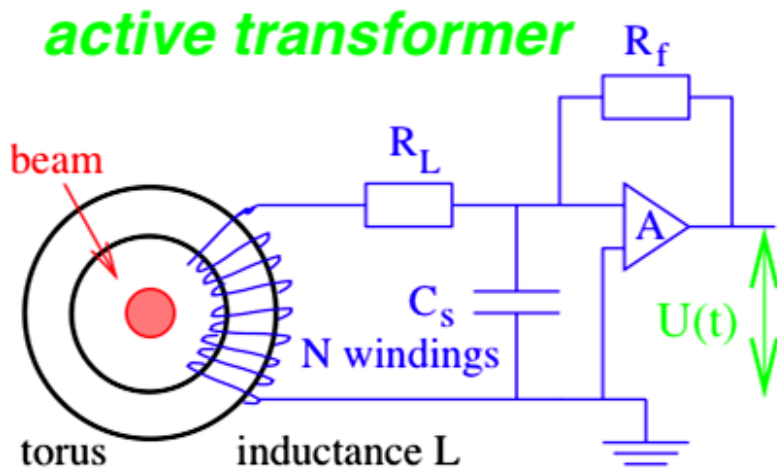

The input resistor is for an op-amp:  $R_f/A \ll R_L$

$$\Rightarrow \tau_{droop} = L/(R_f/A + R_L) \approx L/R_L$$

Droop time constant can be up to 1 s!

The feedback resistor is also used for range switching.

An additional active feedback loop is used to compensate the droop.

# 'Active' Transformer Realization

Active transformer for the measurement of long  $t > 10 \mu\text{s}$  pulses e.g. at pulsed LINACs



Inner / outer radius	30 / 45 mm
Permeability	$\mu_r \approx 10^5$ for $f < 100\text{kHz}$ $\mu_r \propto 1/f$ above
Windings	2x10 crossed
Max. sensitivity	$10^6$ V/A with amplifier
Current resolution	$0.2 \mu\text{s}$ for full BW
Droop	0.5 % per 5 ms
Rise time	200 ns
Bandwidth	2 kHz ... 1 MHz

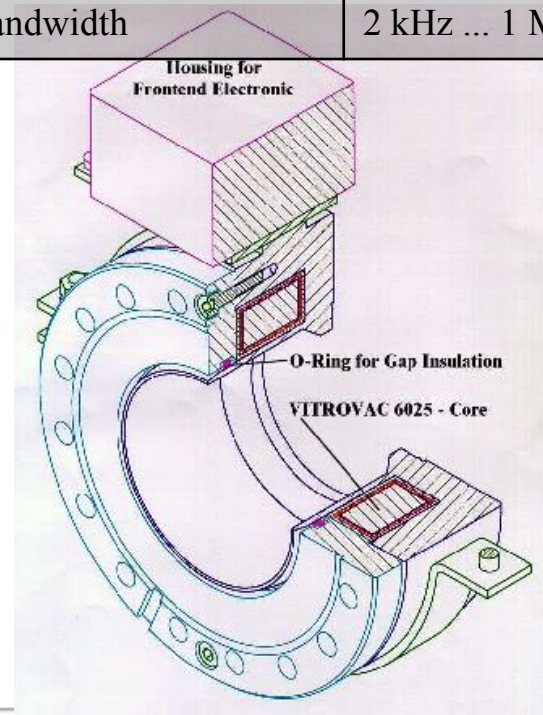

# 'Active' Transformer Measurement

Active transformer for the measurement of long  $t > 10 \mu\text{s}$  pulses e.g. at pulsed LINACs

**Example:** Transmission and macro-pulse shape for  $\text{Ni}^{2+}$  beam at GSI LINAC

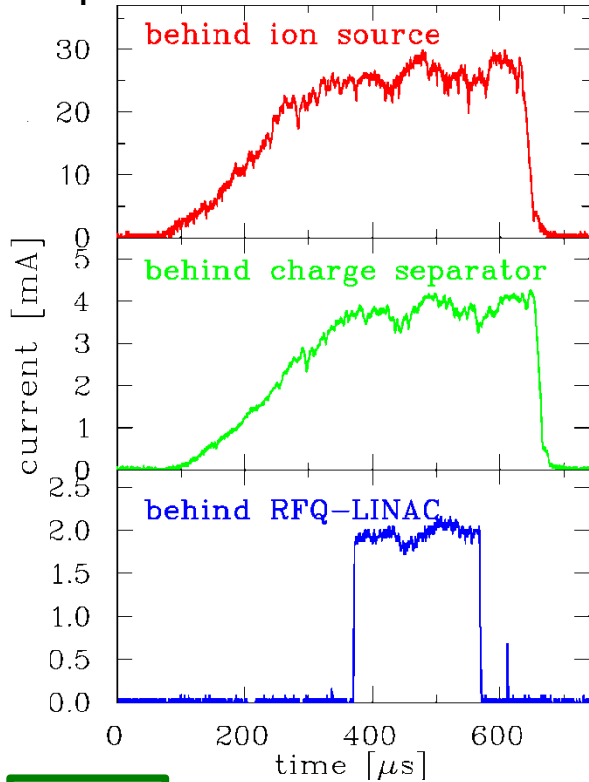

**Example:** Multi-turn injection of a  $\text{Ni}^{26+}$  beam into GSI Synchrotron, 5  $\mu\text{s}$  per turn

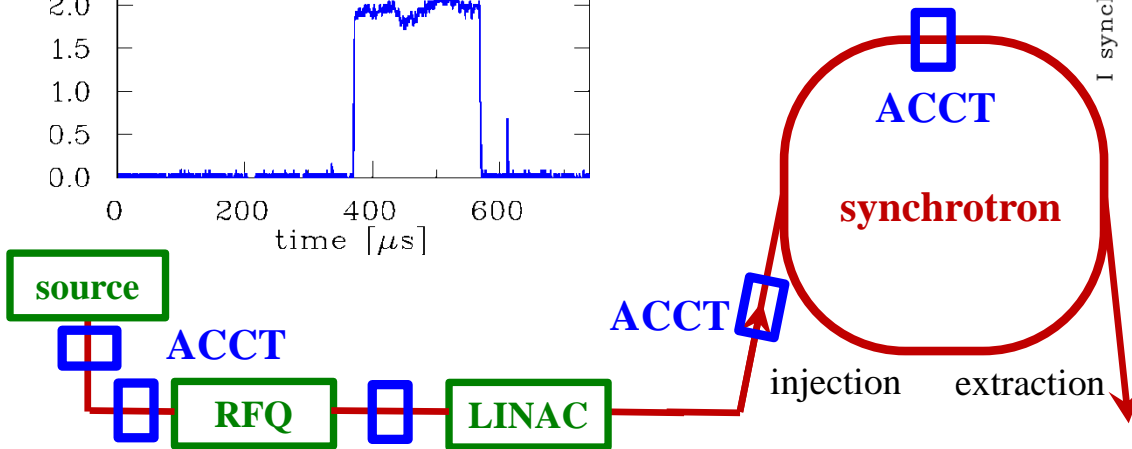
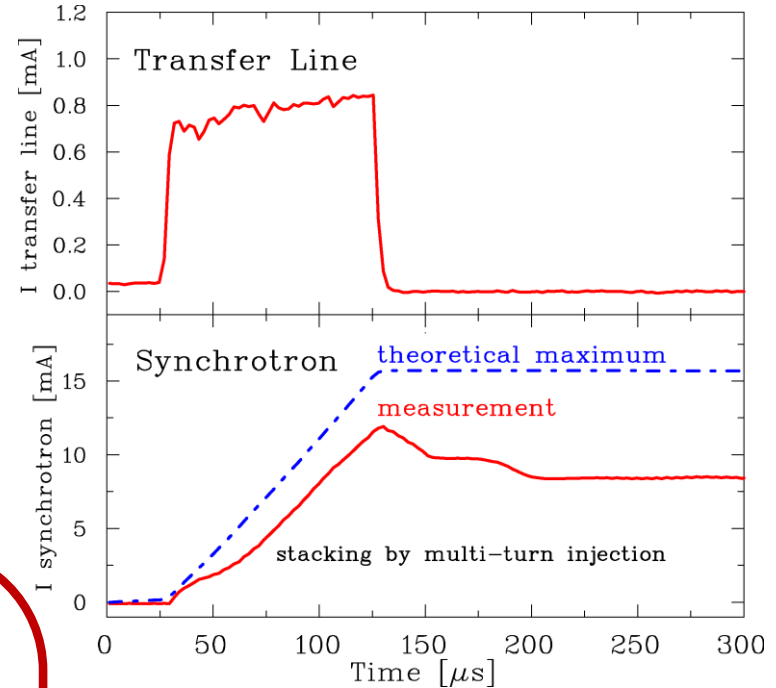

→ Transformer are frequently used for operation.

# Shielding of a Transformer

## Task of the shield:

- The image current of the walls have to be bypassed by a gap and a metal housing.
- This housing uses  $\mu$ -metal and acts as a shield of external B-field  
(remember:  $I_{beam} = 1 \mu\text{A}$ ,  $r = 10 \text{ cm} \Rightarrow B_{beam} = 2\text{pT}$ , earth field  $B_{earth} = 50 \mu\text{T}$ )

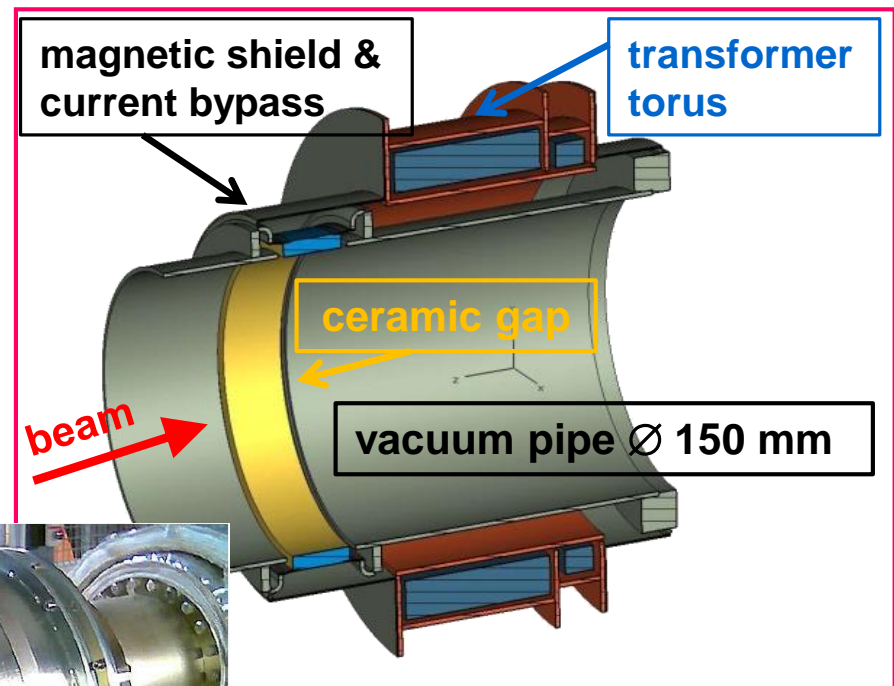
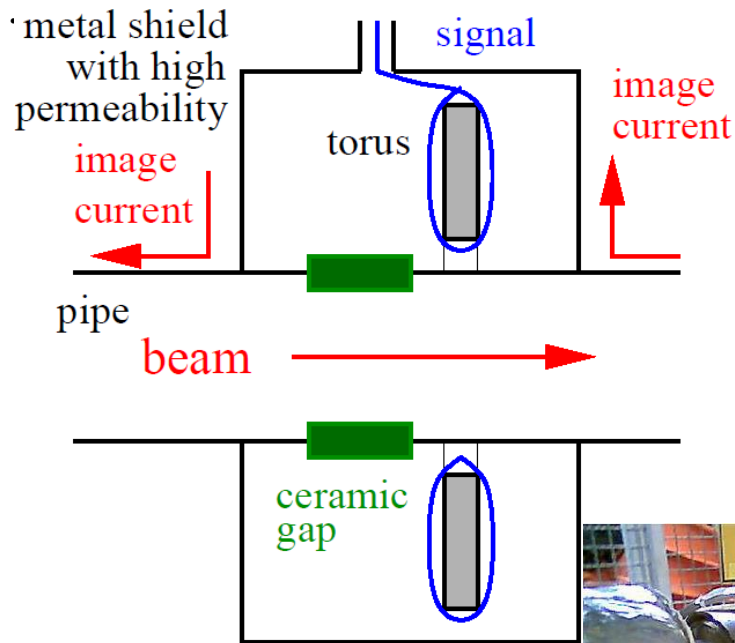

# Design Criteria for a Current Transformer

## Criteria:

1. The output voltage is  $U \propto I/N \Rightarrow$  low number of windings for large signal.
2. For a longer droop time, a large inductance  $L$  is required due to  $\tau_{droop} = L/R$ :  
 $L \propto N^2$  and  $L \propto \mu_r$  ( $\mu_r \approx 10^5$  for amorphous alloy)
3. For a large bandwidth the integrating capacitance  $C_s$  should be low  $\tau_{rise} = \sqrt{L_s C_s}$

Depending on applications the behavior is influenced by external elements:

➤ **Passive transformer:**  $R = 50 \Omega$ ,  $\tau_{rise} \approx 1$  ns for short pulses

*Application:* Transfer between synchrotrons :  $100 \text{ ns} < t_{pulse} < 10 \mu\text{s}$

➤ **Active transformer:** Current sink by I/U-converter,  $\tau_{droop} \approx 1$  s for long pulses

*Application:* macro-pulses at LINACs :  $100 \mu\text{s} < t_{pulse} < 10 \text{ ms}$

## General:

- The beam pipe has to be intersected to prevent the flow of the image current through the torus
- The torus is made of  $25 \mu\text{m}$  isolated flat ribbon spiraled to get a torus of  $\approx 15 \text{ mm}$  thickness, to have large electrical resistivity
- Additional winding for calibration with current source

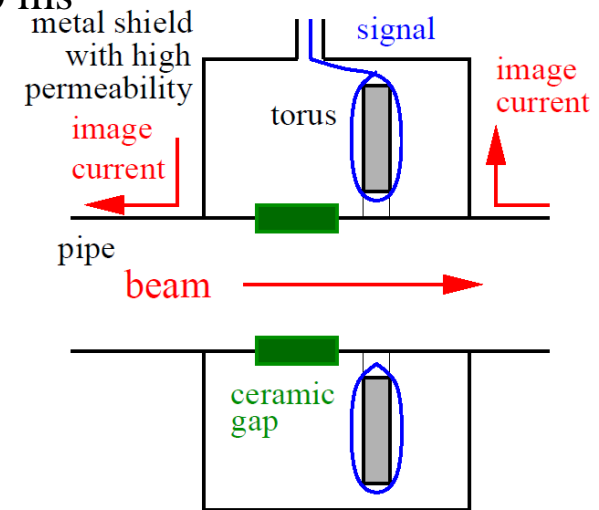

# The Artist' View of Transformers

The active transformer ACCT



The passive, fast transformer FCT

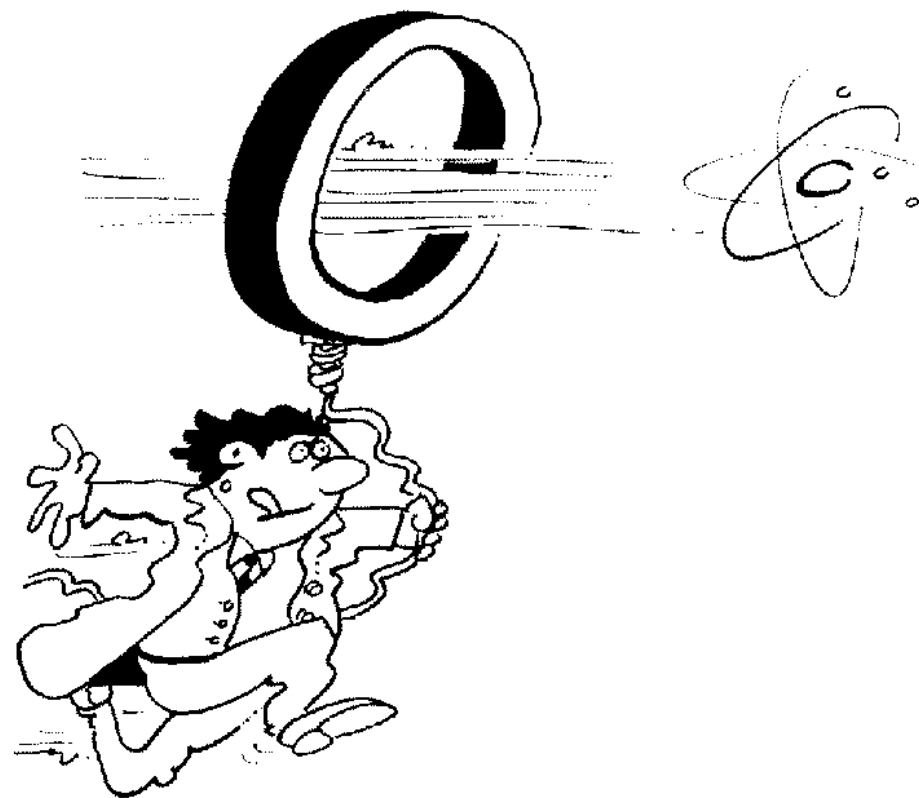

Cartoons by Company Bergoz, Saint Genis

# The dc Transformer

How to measure the DC current? The current transformer discussed sees only B-flux *changes*. The DC Current Transformer (DCCT) → look at the magnetic saturation of two torii.

- **Modulation** of the primary windings forces both torii into saturation twice per cycle
- **Sense windings** measure the modulation signal and cancel each other.
- But with the  $I_{beam}$ , the saturation is shifted and  $I_{sense}$  is not zero
- **Compensation current** adjustable until  $I_{sense}$  is zero once again

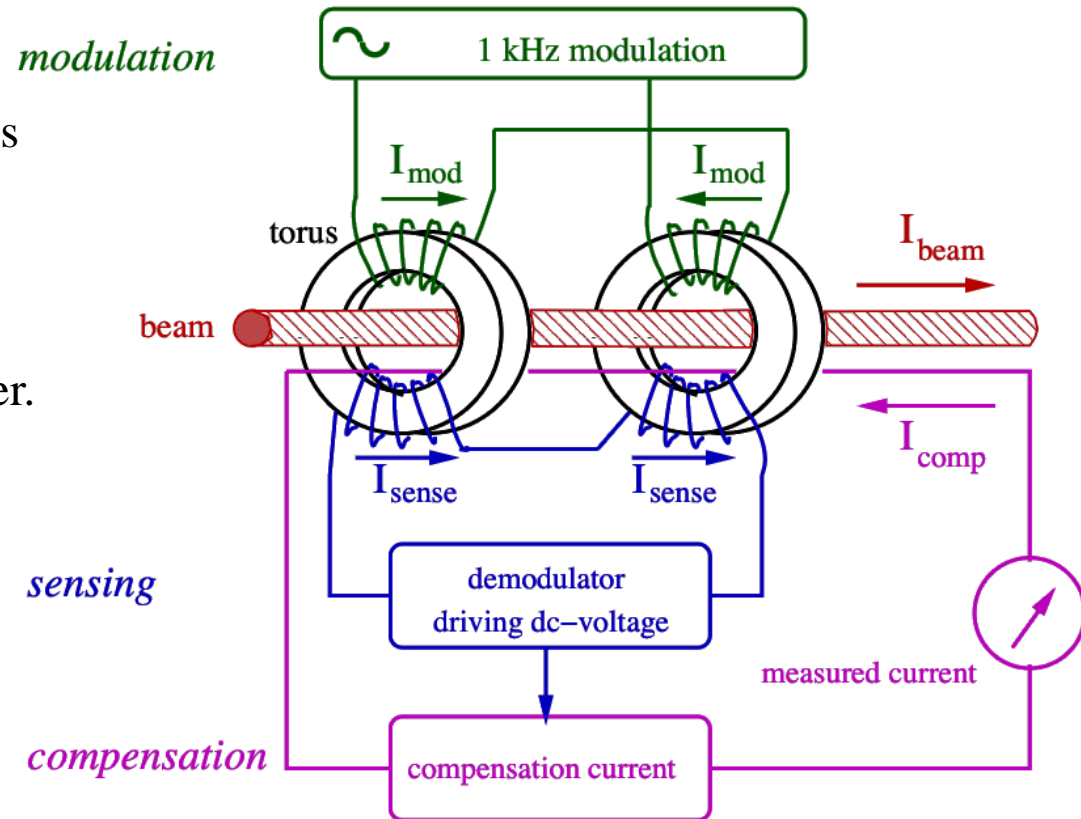

# The dc Transformer

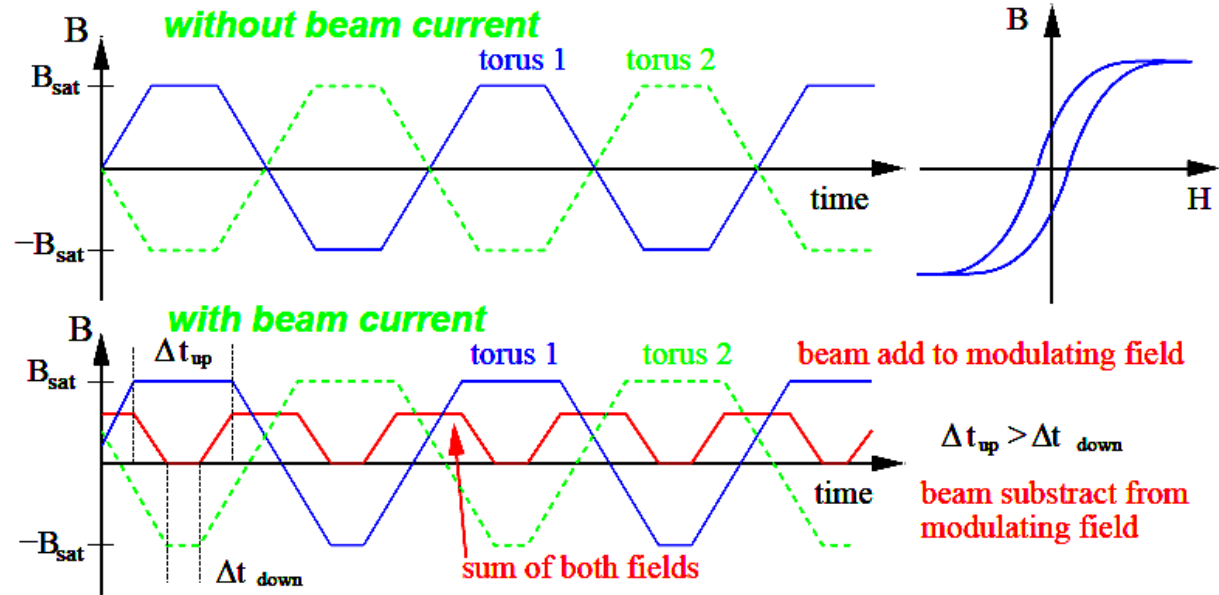

➤ **Modulation without beam:**

typically about 1 kHz to saturation → **no net flux**

➤ **Modulation with beam:**

saturation is reached at different times, → net flux

➤ **Net flux:** double frequency than modulation

➤ **Feedback:** Current fed to compensation winding

for larger sensitivity

➤ **Two magnetic cores:** Must be very similar.

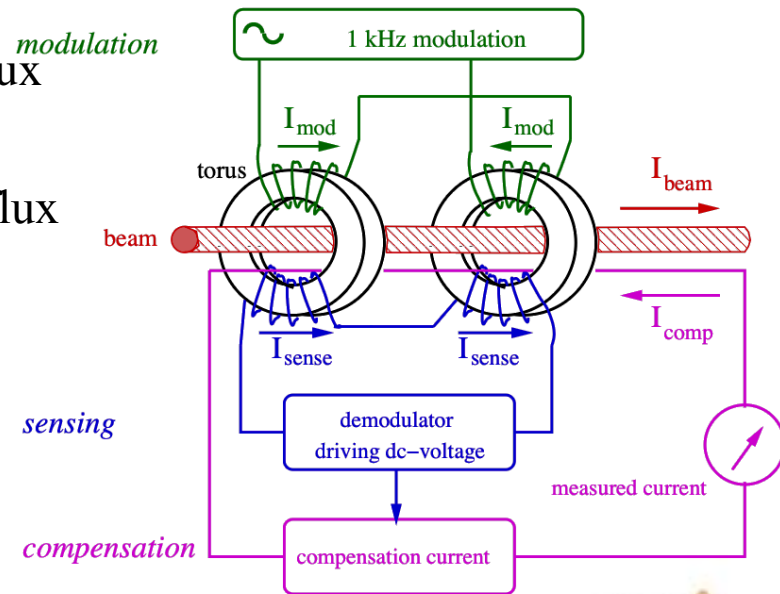



# The dc Transformer Realization

Example: The DCCT at GSI synchrotron  
(designed 1990 at GSI):

Torus radii	$r_i = 135 \text{ mm}$ $r_o = 145 \text{ mm}$
Torus thickness	$d = 10 \text{ mm}$
Torus permeability	$\mu_r = 10^5$
Saturation inductance	$B_{\text{sat}} = 0.6 \text{ T}$
Number of windings	16 for modulation & sensing 12 for feedback
Resolution	$I_{\text{beam}}^{\text{min}} = 2 \text{ } \mu\text{A}$
Bandwidth	$\Delta f = \text{dc} \dots 20 \text{ kHz}$
Rise time constant	$\tau_{\text{rise}} = 10 \text{ } \mu\text{s}$
Temperature drift	$1.5 \text{ } \mu\text{A}/^\circ\text{C}$

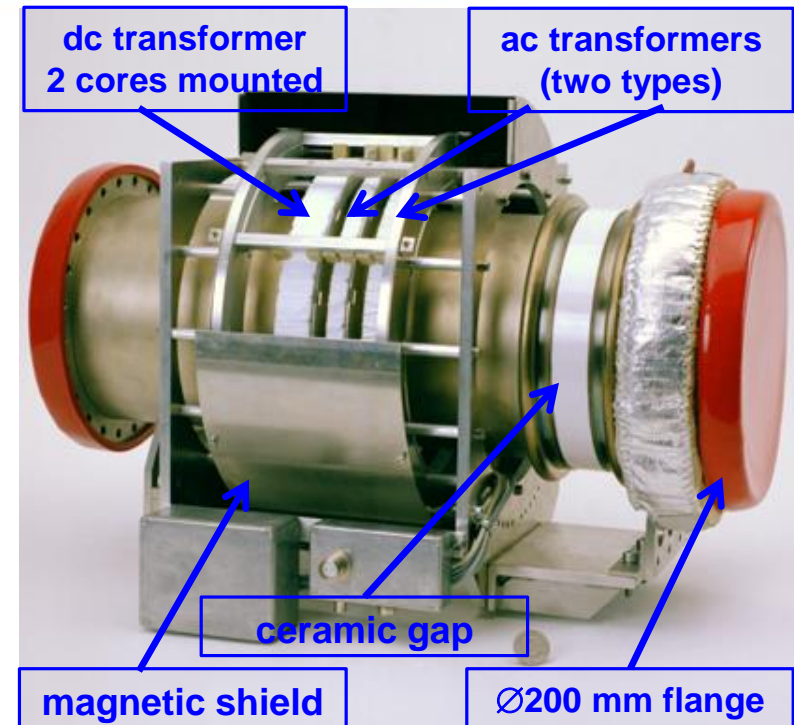

In-flange NPCT with 96-mm aperture

Recent commercial product specification (Bergoz NPCT):

Most parameters are comparable the GSI-model

Temperature coefficient  $0.5 \text{ } \mu\text{A}/^\circ\text{C}$

Resolution  $\approx 10 \text{ } \mu\text{A}$  (i.e. not optimized)

# Measurement with a dc Transformer

**Example:** The DCCT at GSI synchrotron:

⇒ Observation of beam behavior with 20 μs time resolution → most important operation tool.

**Example:** U<sup>73+</sup> accelerated from

11.4 MeV/u ( $\beta = 15.5\%$ ) to 750 MeV/u ( $\beta = 84\%$ )

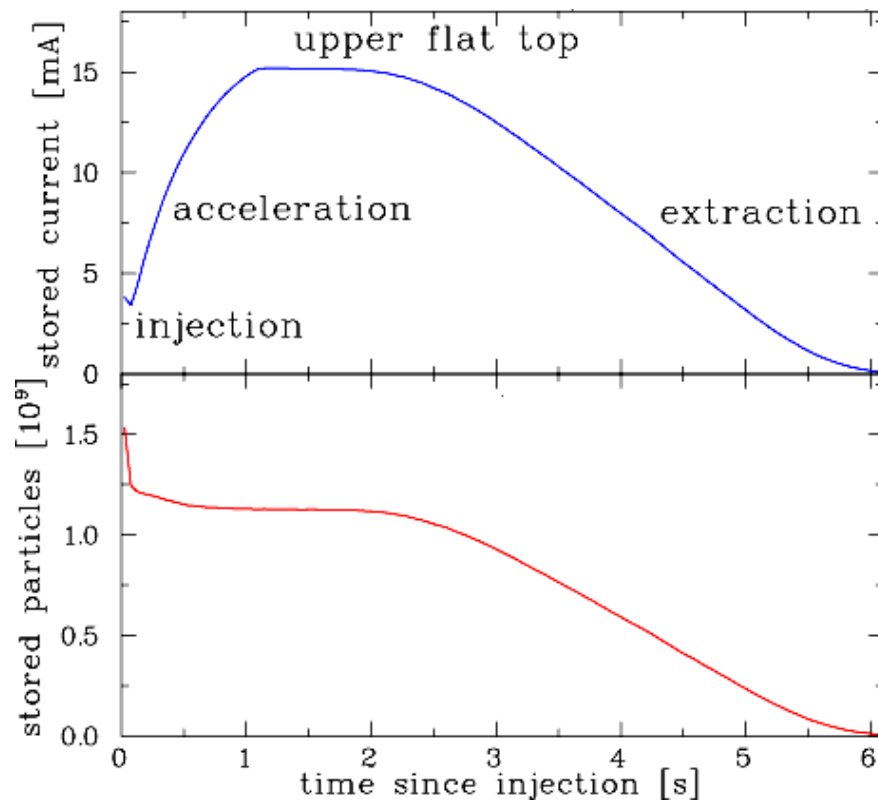

**Important parameter:**

**Detection threshold: 1 μA**

(= resolution)

Bandwidth: dc to 20 kHz

Rise-time: 20 μs

Temperature drift: 1.5 μA/°C

⇒ compensation required.

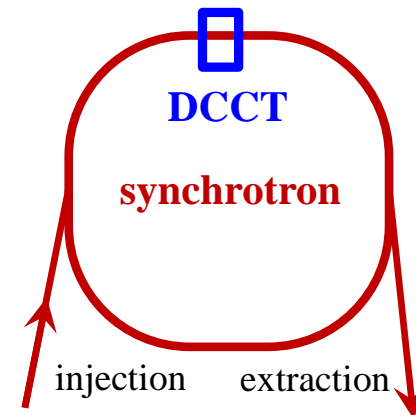

# Design Criteria and Limitations for a dc Transformer

Careful shielding against external fields with  $\mu$ -metal.

- High resistivity of the core material to prevent for eddy current
  - ⇒ thin, insulated strips of alloy.
- Barkhausen noise due to changes of Weiss domains
  - ⇒ unavoidable limit for **DCCT**.
- Core material with low changes of  $\mu_r$  due to temperature and stress
  - ⇒ low micro-phonic pick-up.
- Thermal noise voltage  $U_{eff} = \sqrt{4k_B T \cdot R \cdot f}$ 
  - ⇒ design for only required bandwidth  $f$ , low input resistor  $R$  preferred.
- Preventing for flow of secondary electrons through the core
  - ⇒ need for well controlled beam centering close to the transformer.

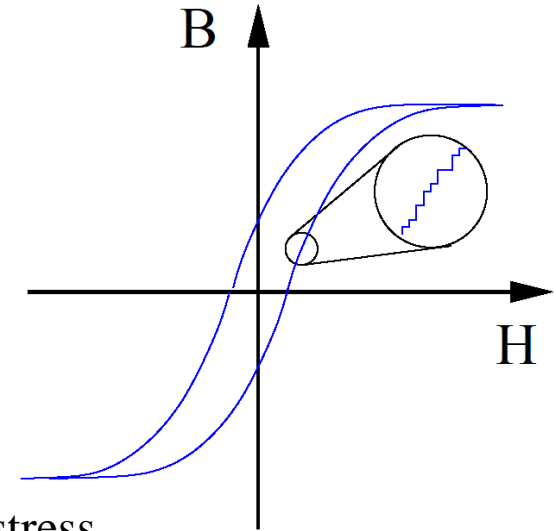

⇒ **The lowest measurable current:  $\approx 1 \mu\text{A}$  for DCCT**  
 $\approx 30 \mu\text{A}$  for FCT with 500 MHz bandwidth  
 $\approx 0.3 \mu\text{A}$  for ACCT with 1 MHz bandwidth.

# The Artist' View of Transformers

The active transformer ACCT



The Fast Transformer FCT

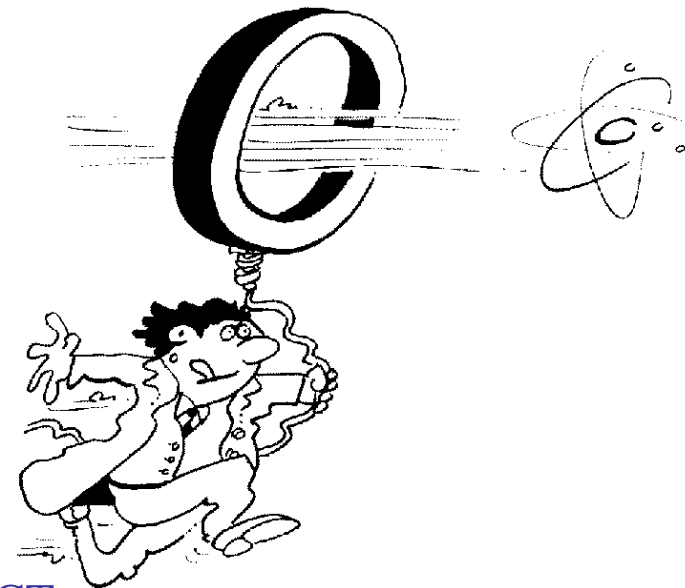

The dc transformer DCCT

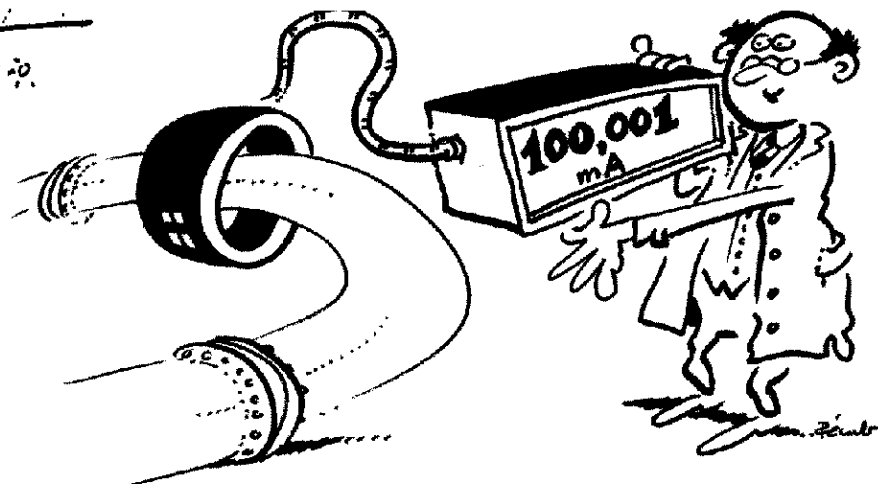

Company Bergoz

# Measurement of Beam Current

The beam current is the basic quantity of the beam.

- It is the first check of the accelerator functionality
- It has to be determined in an absolute manner
- Important for transmission measurement and to prevent beam losses.

## Different devices are used:

- **Transformers:** Measurement of the beam's **magnetic field**

They are non-destructive. No dependence on beam energy

They have lower detection threshold.

- **Faraday cups:** Measurement of the beam's **electrical charges**

They are destructive. For low energies only

Low currents can be determined.

- **Particle detectors:** Measurement of the particle's **energy loss** in matter

Examples are scintillators, ionization chambers, secondary e<sup>-</sup> emission monitors

Used for low currents at high energies e.g. for slow extraction from a synchrotron.

# Excuse: Energy Loss of Ions in Copper

Bethe Bloch formula:  
(simplest formulation)

$$-\frac{dE}{dx} = 4\pi N_A r_e m_e c^2 \cdot \frac{Z_t}{A_t} \rho_t \cdot \frac{Z_p^2}{\beta^2} \left( \ln \frac{2m_e c^2 \gamma^2 \beta^2}{I} - \beta^2 \right)$$

## Semi-classical approach:

- Projectiles of mass  $M$  collide with free electrons of mass  $m$
- If  $M \gg m$  then the relative energy transfer is low
- ⇒ many collisions required many electrons participate

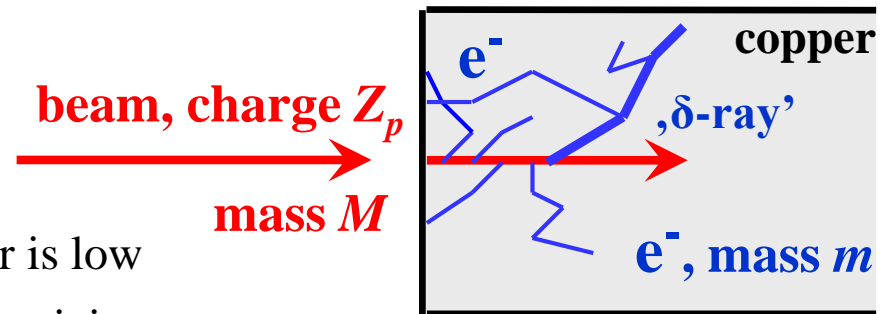

proportional to electron density  $n_e = \frac{Z_t}{A_t} \rho_t$

⇒ low straggling for the heavy projectile i.e. ‘straight trajectory’

- If projectile velocity  $\beta \approx 1$  low relative energy change of projectile ( $\gamma$  is Lorentz factor)
- $I$  is mean ionization potential including kinematic corrections  $I \approx Z_t \cdot 10 \text{ eV}$  for most metals
- Strong dependence on projectile charge  $Z_p$  as  $\frac{dE}{dx} \propto Z_p^2$

Constants:  $N_A$  Avogadro number,  $r_e$  classical  $e^-$  radius,  $m_e$  electron mass,  $c$  velocity of light

# Excuse: Energy Loss of Ions in Copper

Bethe Bloch formula: 
$$-\frac{dE}{dx} = 4\pi N_A r_e m_e c^2 \cdot \frac{Z_t}{A_t} \rho_t \cdot \frac{Z_p^2}{\beta^2} \left( \ln \frac{2m_e c^2 \gamma^2 \beta^2}{I} - \beta^2 \right)$$

Range: 
$$R = \int_0^{E_{\max}} \left( \frac{dE}{dx} \right)^{-1} dE$$

with approx. scaling  $R \propto E_{\max}^{1.75}$

Numerical calculation

with semi-empirical model e.g. SRIM

Main modification  $Z_p \rightarrow Z_p^{\text{eff}}(E_{\text{kin}})$

$\Rightarrow$  Cups only for

$E_{\text{kin}} < 100 \text{ MeV/u}$  due to  $R < 10 \text{ mm}$

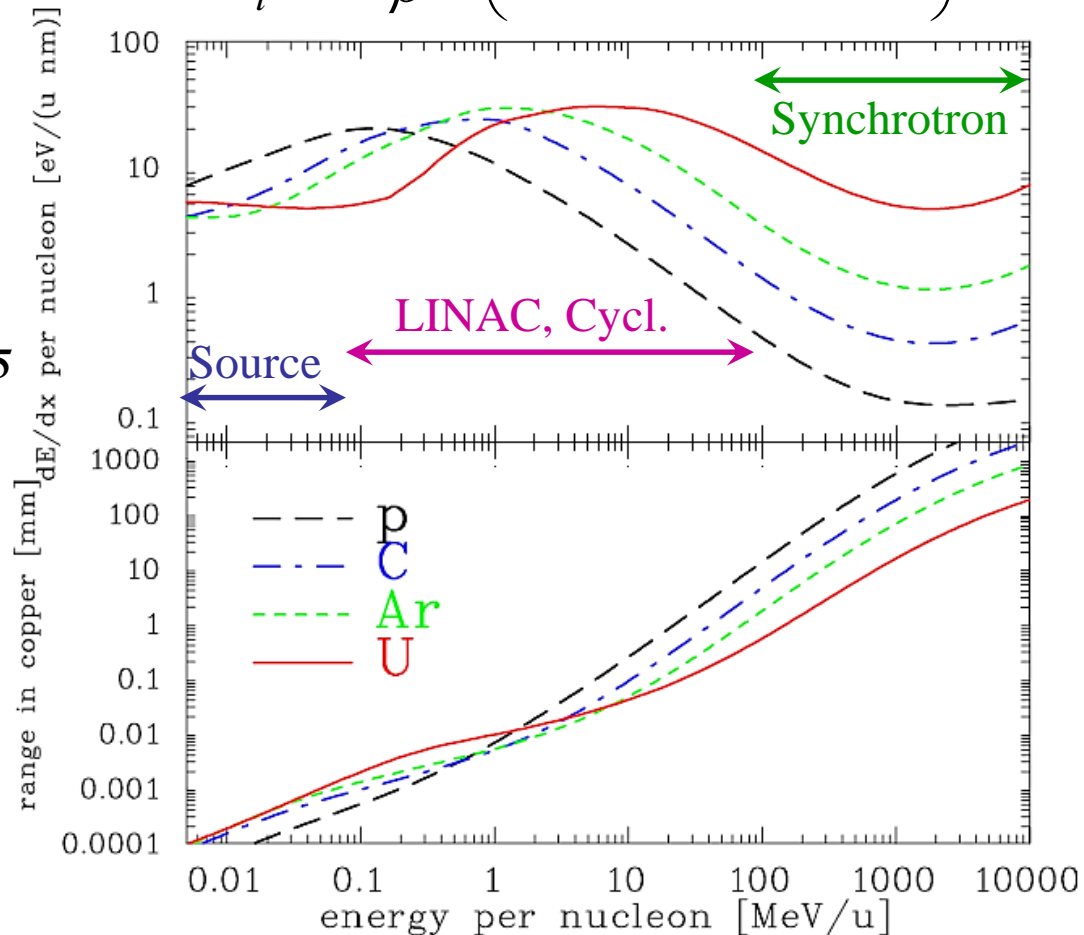

# Excuse: Secondary Electron Emission by Ion Impact

Energy loss of ions in metals close to a surface:

Closed collision with large energy transfer:  $\rightarrow$  fast  $e^-$  with  $E_{kin} \gg 100$  eV

Distant collision with low energy transfer  $\rightarrow$  slow  $e^-$  with  $E_{kin} \leq 10$  eV

$\rightarrow$  'diffusion' & scattering with other  $e^-$ : scattering length  $L_s \approx 1 - 10$  nm

$\rightarrow$  at surface  $\approx 90\%$  probability for escape

Secondary **electron yield** and energy distribution comparable for all metals!

$$\Rightarrow Y = const. * dE/dx \quad (\text{Sternglass formula})$$

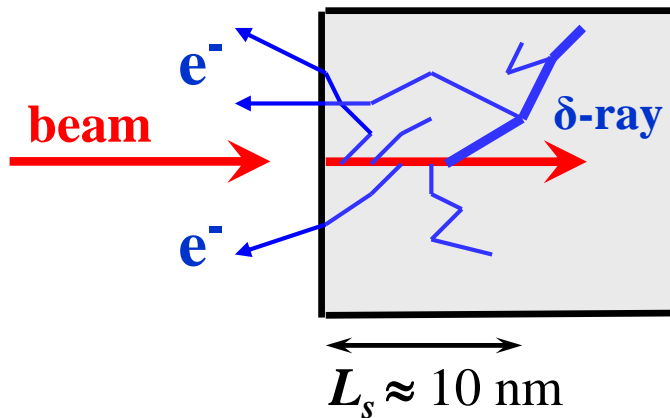

From E.J. Sternglass, Phys. Rev. 108, 1 (1957)

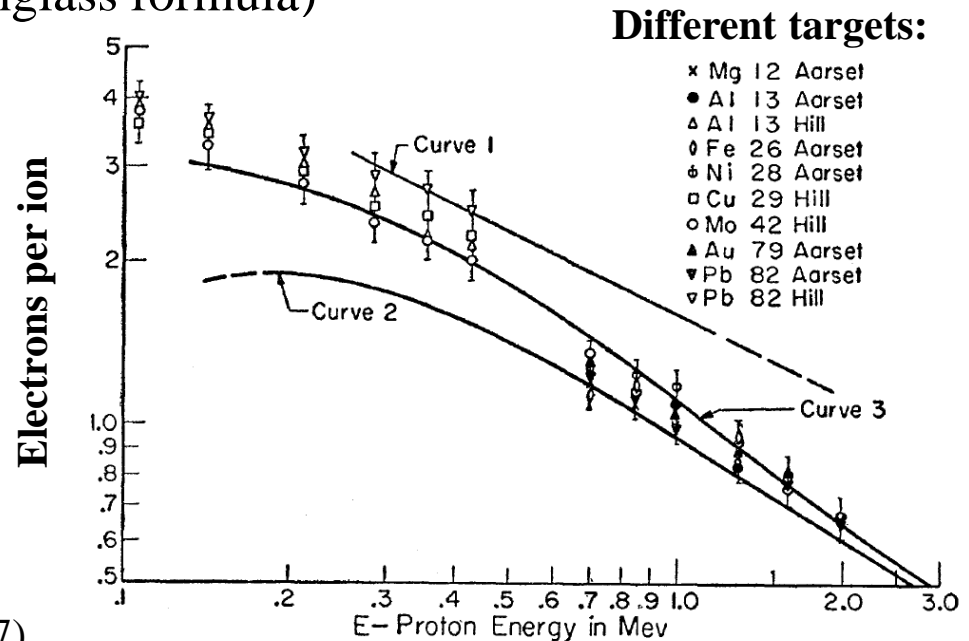



# Excuse: Secondary Electron Emission by Ion Impact

Energy loss of ions in metals close to a surface:

Closed collision with large energy transfer:  $\rightarrow$  fast  $e^-$  with  $E_{kin} \gg 100$  eV

Distant collision with low energy transfer  $\rightarrow$  slow  $e^-$  with  $E_{kin} \leq 10$  eV

$\rightarrow$  'diffusion' & scattering with other  $e^-$ : scattering length  $L_s \approx 1 - 10$  nm

$\rightarrow$  at surface  $\approx 90$  % probability for escape

Secondary **electron yield** and energy distribution comparable for all metals!

$$\Rightarrow Y = const. * dE/dx \quad (\text{Sternglass formula})$$

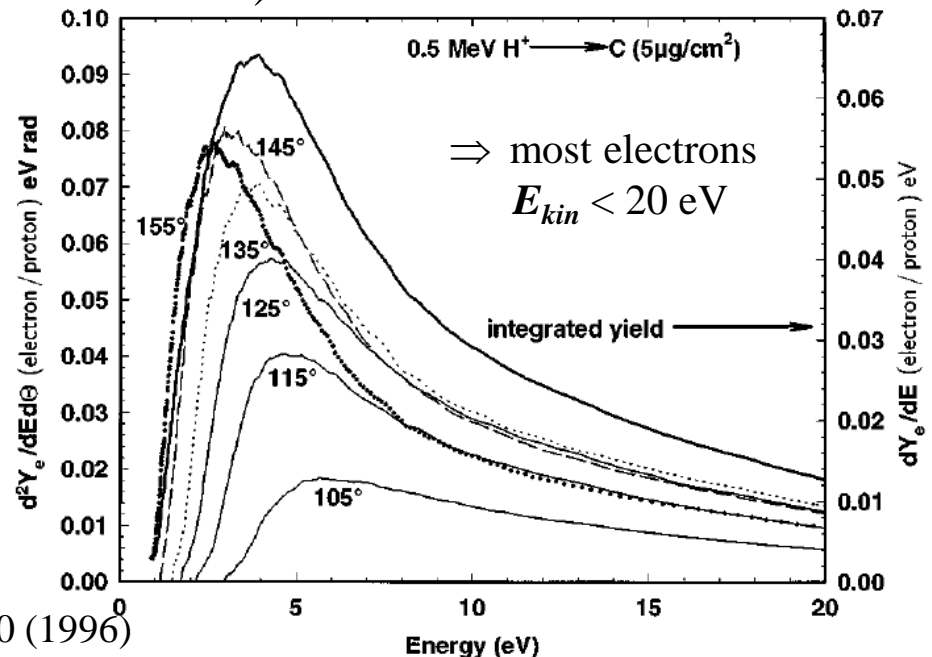
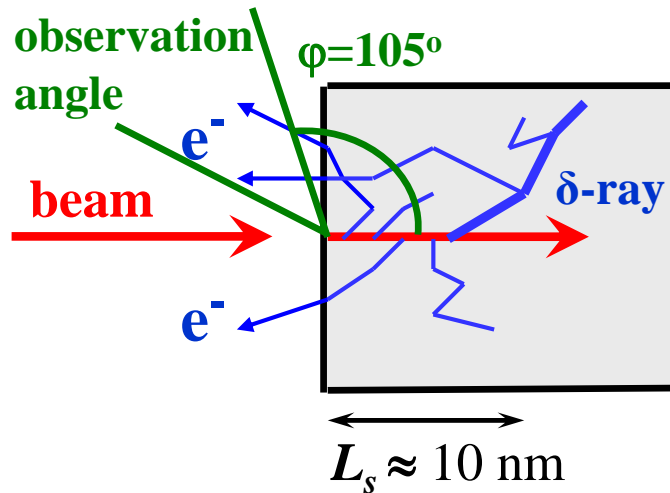

From C.G. Drexler, R.D. DuBois, Phys. Rev. A 53, 1630 (1996)

# Faraday Cups for Beam Charge Measurement

The beam particles are collected inside a metal cup  
 ⇒ The beam's charge are recorded as a function of time.

The cup is moved in the beam pass → destructive device

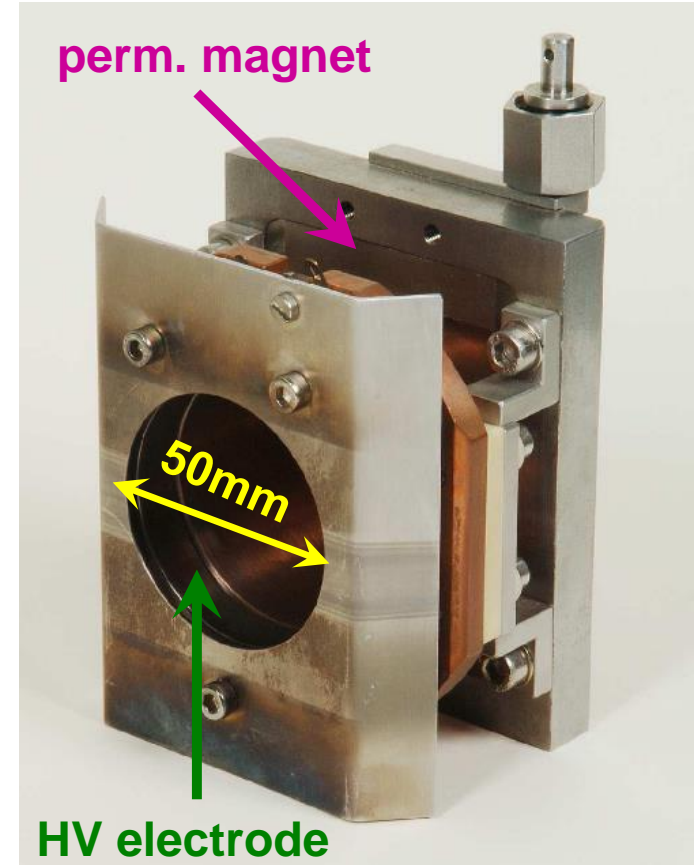
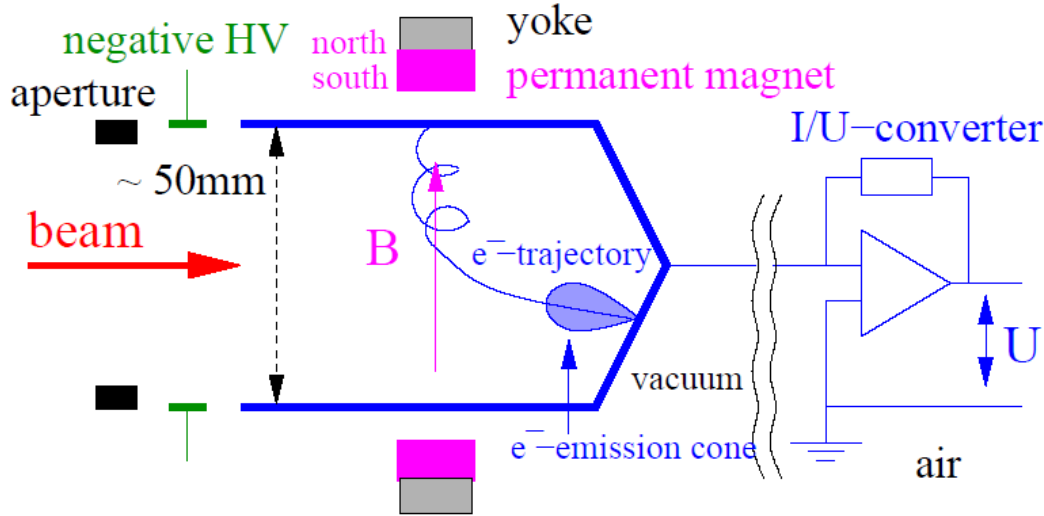

**Currents down to 10 pA with bandwidth of 100 Hz!**

## Magnetic field:

To prevent for secondary electrons leaving the cup  
*and/or*

## Electric field:

Potential barrier at the cup entrance.

# Realization of a Faraday Cup at GSI LINAC

The Cup is moved into the beam pass.

**Faraday Cup**  
Ø60 mm

**vacuum flange**  
here Ø150 mm

**bellow**  
**compression**  
**for movement**

**pneumatic**  
**drive**

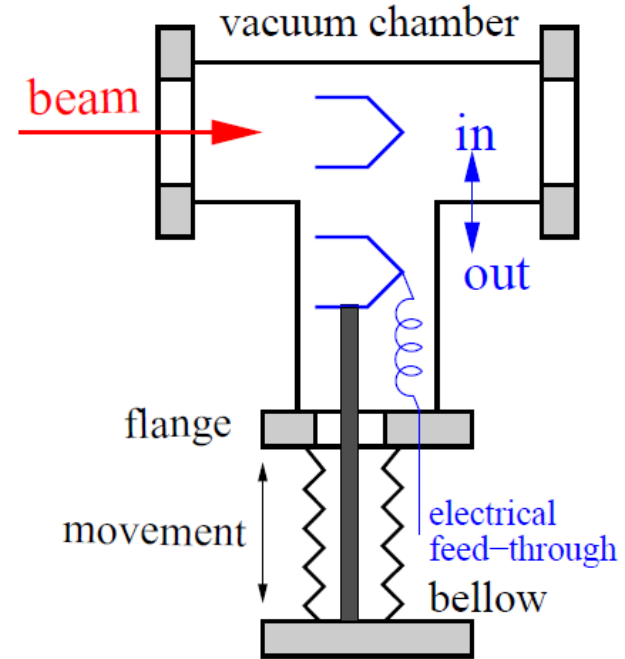
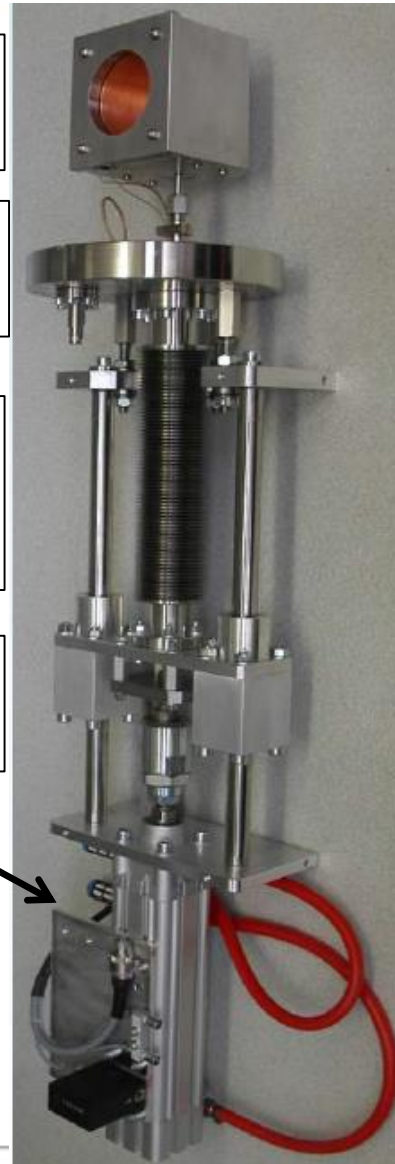

Beam Current Measurement

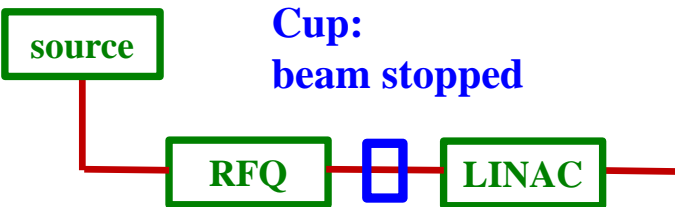

**Cup:**  
**beam stopped**

# Secondary Electron Suppression: Electric Field

A ring shaped electrode is used at the entrance of Faraday Cup:

Typical voltage 100 to 1000 V

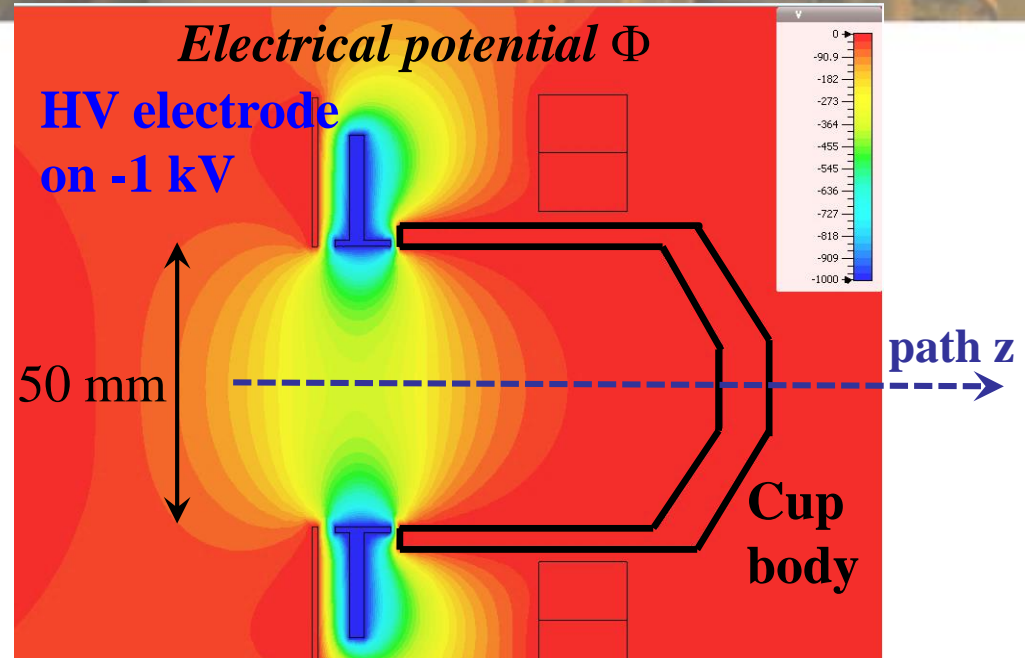
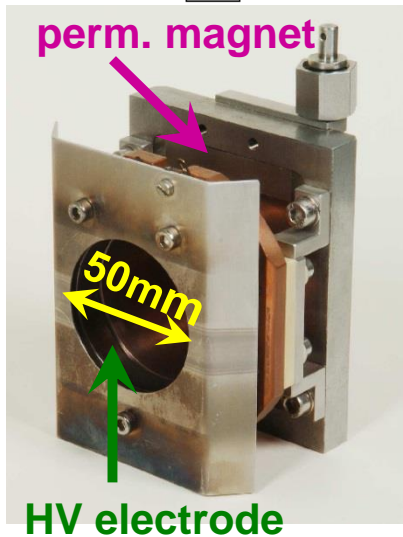
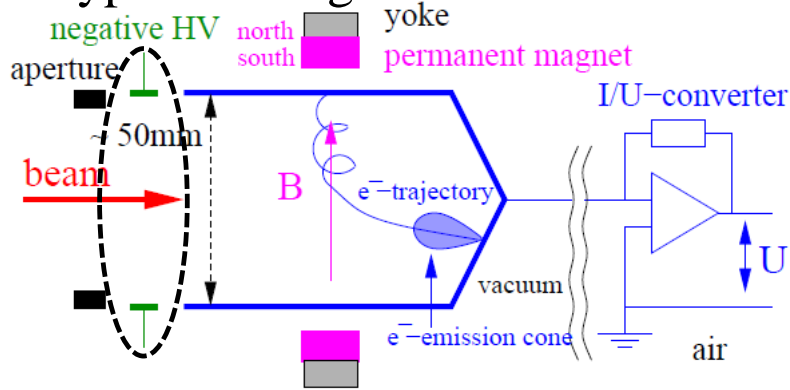

potential on central axis for -1 kV@electrode

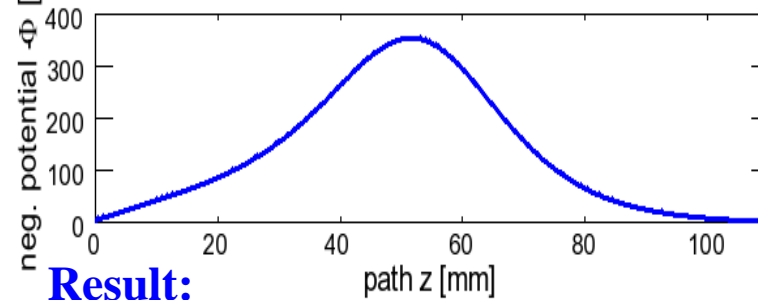

**Result:**

here: potential at center  $\approx 35\%$  of applied voltage

Courtesy of J. Latzko, GSI

# Secondary Electron Suppression: Magnetic Field

Co-Sm permanent magnets within the yoke and the calculated magnetic field lines.  
 The central field strength is  $B \approx 0.1$  T.

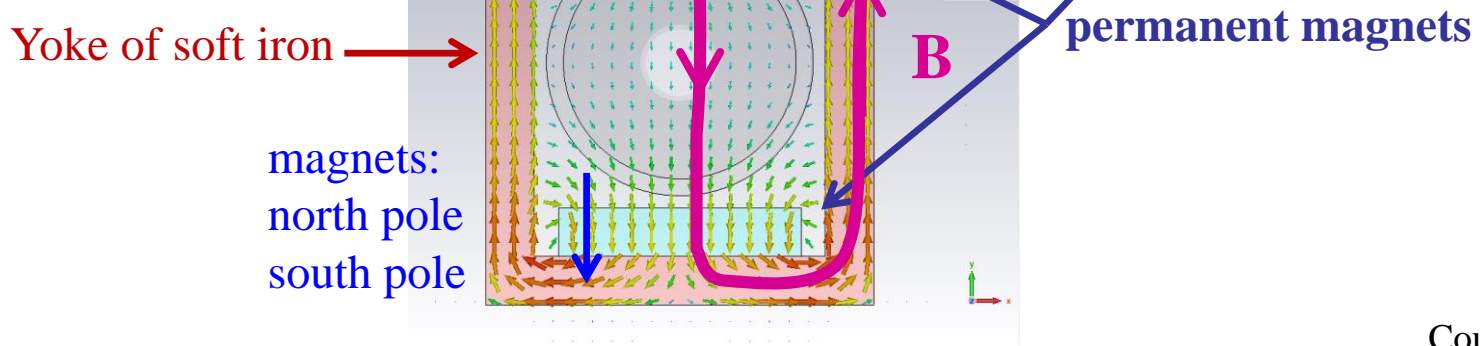
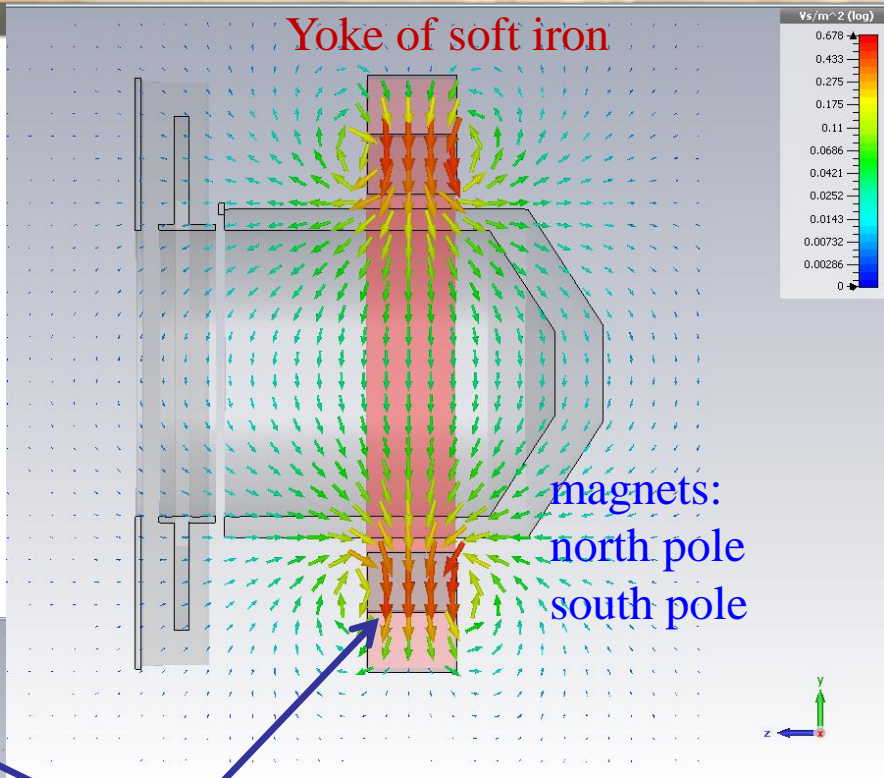
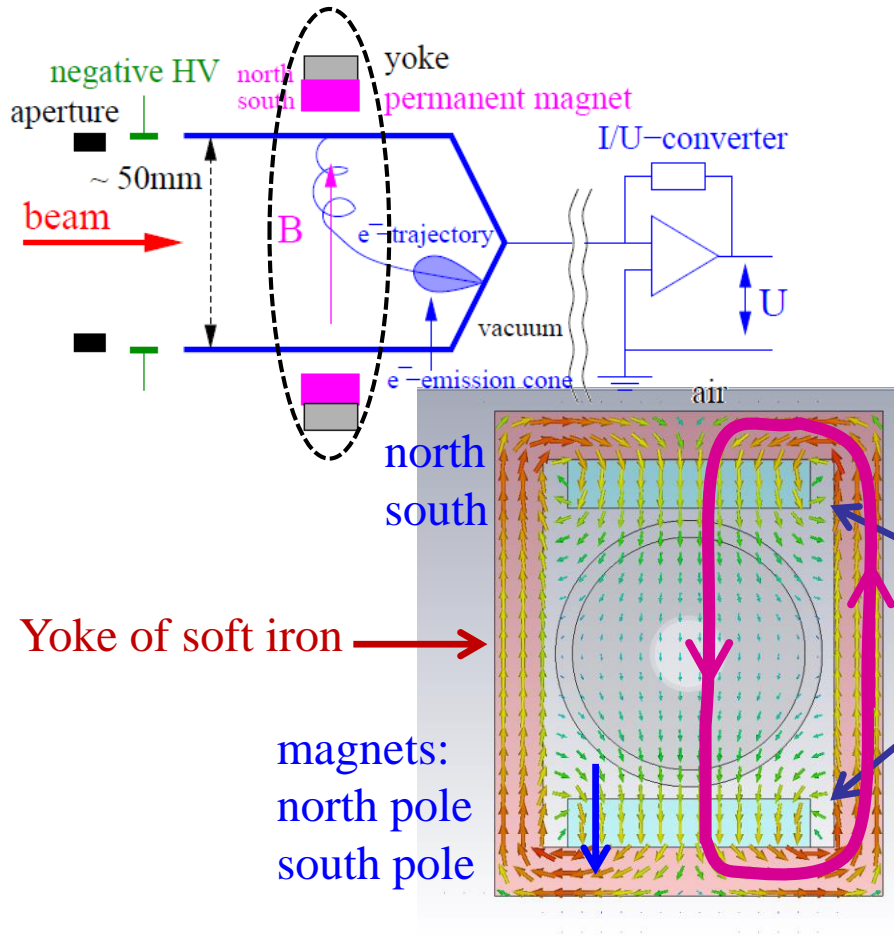

Courtesy of J. Latzko, GSI

# The Artist' View of Faraday Cup

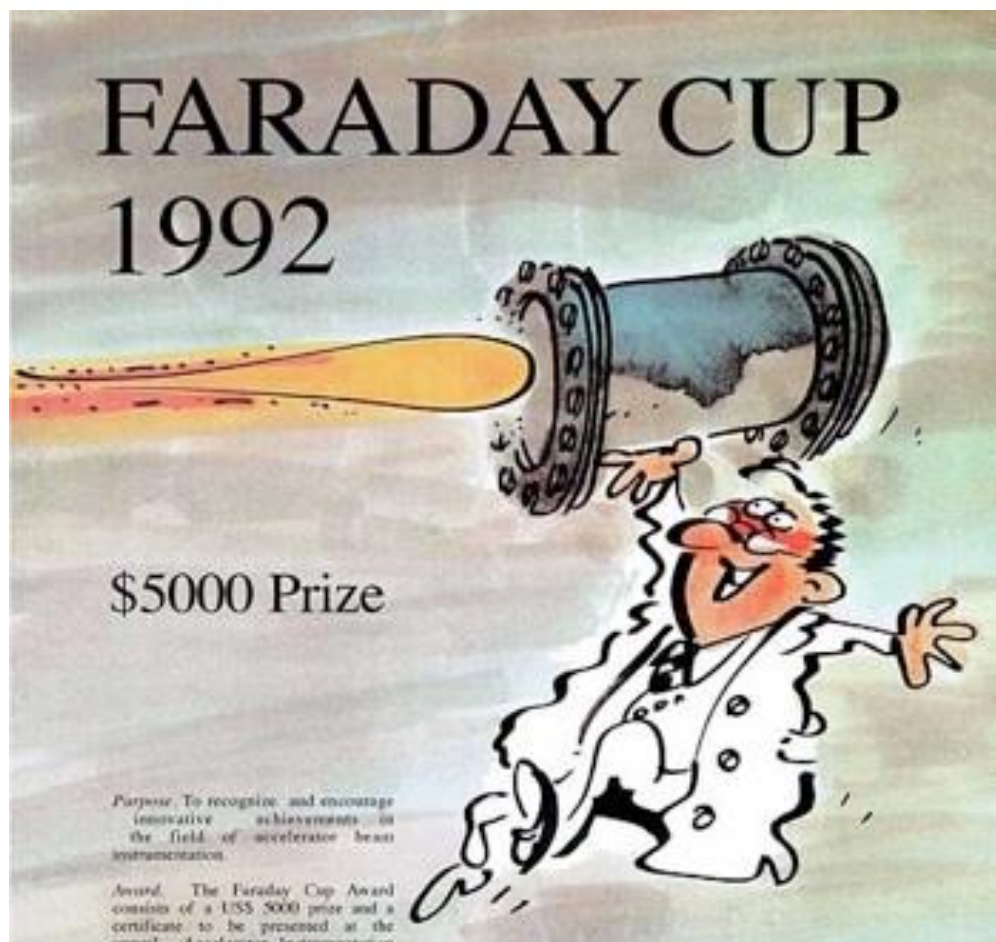

Company Bergoz

# Energy Loss of Electrons in Copper & Faraday Cups of $e^-$

Collisional loss by Bethe-Bloch formula  $dE/dx|_{col} \propto f(E_{kin}) \cdot Z_t$  is valid for all charged particles. However, radiation loss  $dE/dx|_{rad}$  by Bremsstrahlung (i.e.  $\gamma$ -rays of some MeV) dominates for energies above  $E_{kin} > 10$  MeV with the scaling  $dE/dx|_{rad} \propto E_{kin} \cdot Z_t^2$ . Moreover,  $e^-$  shows much larger longitudinal and transverse straggling.

Example of a Faraday cup for 60 MeV Electrons

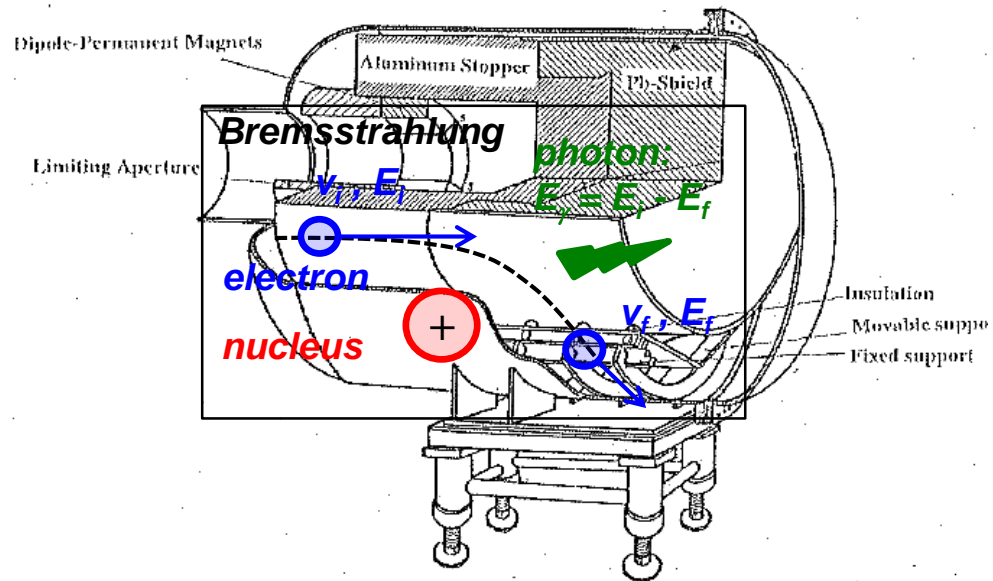
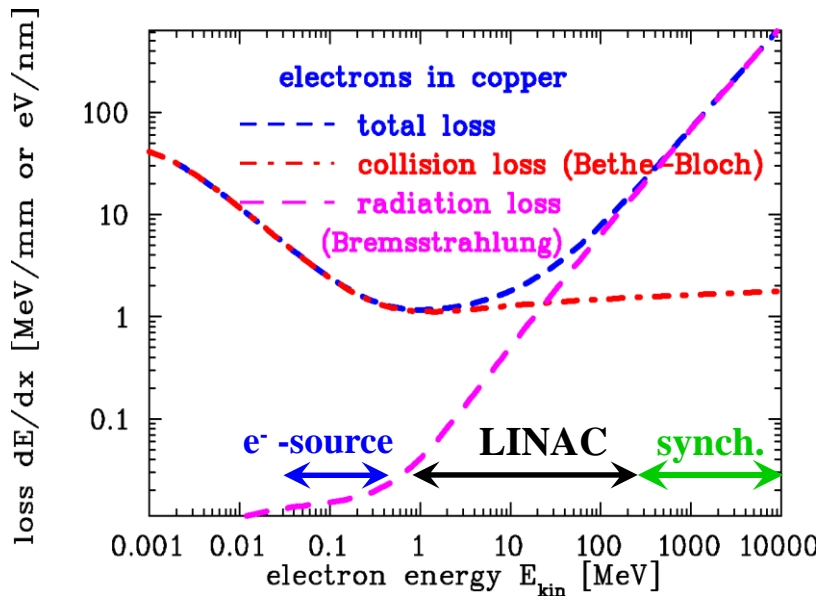

Minimum of Bethe-Bloch  $dE/dx|_{col}$  roughly at  $E_{kin} \approx m_0 c^2 = 511$  keV (rest mass)

$$\Leftrightarrow \beta \approx 90\% \text{ and } \gamma = \frac{1}{\sqrt{1-\beta^2}} \approx 2$$

Al stopper: Stopping of  $e^-$  gently in low-Z material  
 Pb-shield: Absorption of Bremsstrahlungs- $\gamma$   
 $\Rightarrow$  Used as beam dump

# Energy Loss of Electrons in Copper & Faraday Cups of $e^-$

Collisional loss by Bethe-Bloch formula  $dE/dx|_{col} \propto f(E_{kin}) \cdot Z_t$  is valid for all charged particles. However, radiation loss  $dE/dx|_{rad}$  by Bremsstrahlung (i.e.  $\gamma$ -rays of some MeV) dominates for energies above  $E_{kin} > 10$  MeV with the scaling  $dE/dx|_{rad} \propto E_{kin} \cdot Z_t^2$ . Moreover,  $e^-$  shows much larger longitudinal and transverse straggling.

Example of a Faraday cup for 60 MeV Electrons

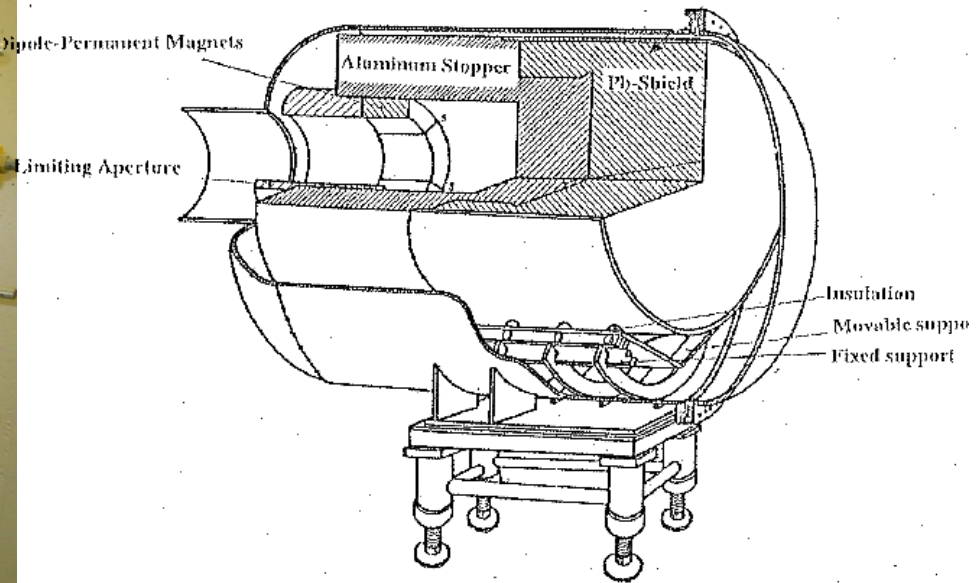
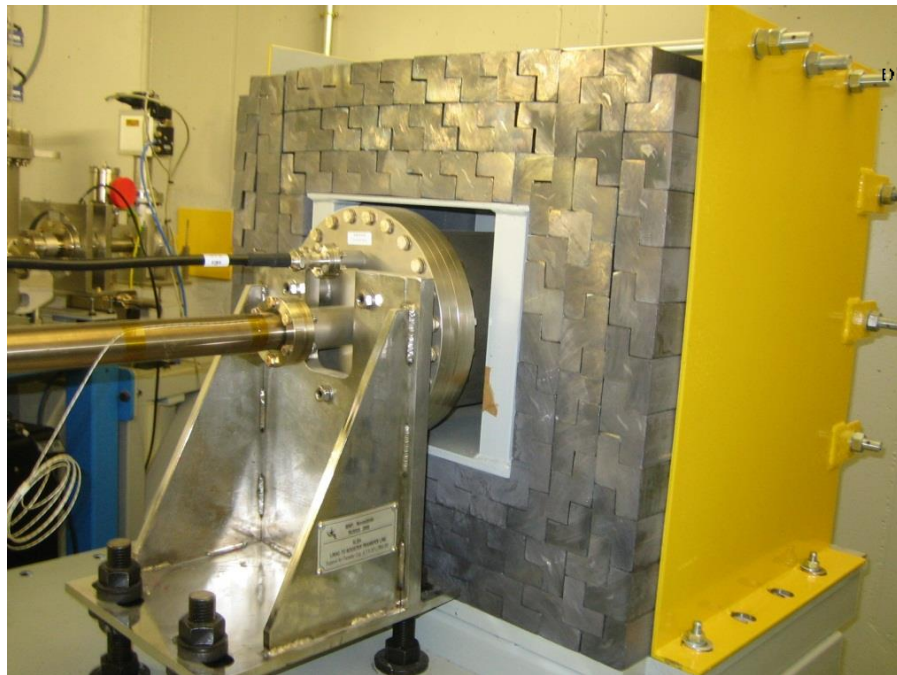

Faraday Cup at ALBA used as beam dump  
From U. Iriso (ALBA)

Al stopper: Stopping of  $e^-$  gently in low-Z material  
Pb-shield: Absorption of Bremsstrahlungs- $\gamma$   
 $\Rightarrow$  Used as beam dump



# Measurement of Beam Current

The beam current is the basic quantity of the beam.

- It is the first check of the accelerator functionality
- It has to be determined in an absolute manner
- Important for transmission measurement and to prevent beam losses.

## Different devices are used:

- **Transformers:** Measurement of the beam's **magnetic field**

They are non-destructive. No dependence on beam energy

They have lower detection threshold.

- **Faraday cups:** Measurement of the beam's **electrical charges**

They are destructive. For low energies only

Low currents can be determined.

- **Particle detectors:** Measurement of the particle's **energy loss** in matter

Examples are scintillators, ionization chambers, secondary e<sup>-</sup> emission monitors

Used for low currents at high energies e.g. for slow extraction from a synchrotron.

# Low Current Measurement for slow Extraction

Slow extraction from synchrotron: lower current compared to LINAC, but higher energies and larger range  $R \gg 1$  cm.

➤ **Particle counting:**

max:  $r \approx 10^6$  1/s

➤ **Energy loss in gas (IC):**

min:  $I_{sec} \approx 1$  pA

max:  $I_{sec} \approx 1$  μA

➤ **Sec. e<sup>-</sup> emission:**

min:  $I_{sec} \approx 1$  pA

➤ **Max. synch. filling:**

Space Charge Limit (SCL).

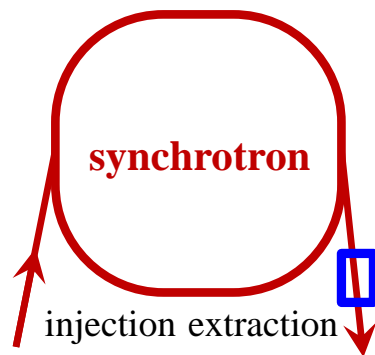

Scint., IC & SEM

Particle detector technologies for ions of 1 GeV/u,  $A = 1$  cm<sup>2</sup>:

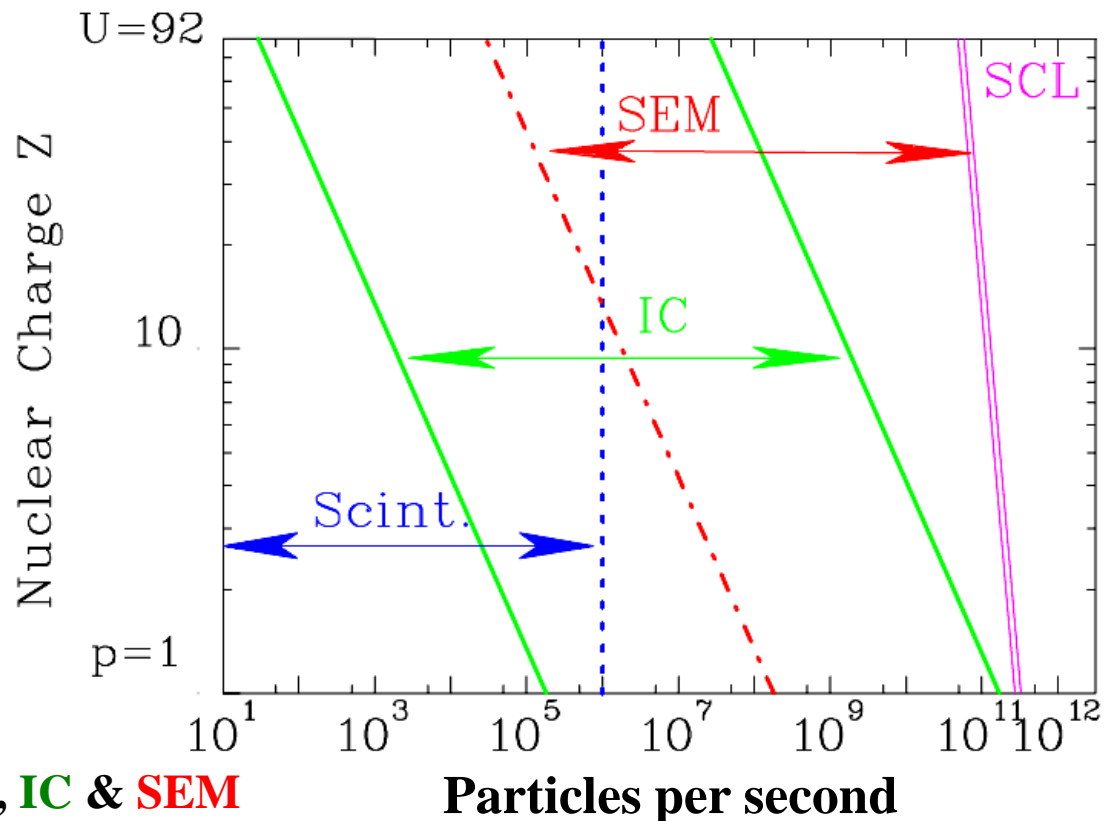

# Example of Scintillator Counter

Example: Plastic Scintillator i.e. organic fluorescence molecules in a plastic matrix

Here: BC 400 (emission  $\lambda_{max} = 420 \text{ nm}$ , pulse width  $\approx 3 \text{ ns} + \text{cable dispersion}$ , size )

**Advantage:** any mechanical form, cheap, blue wave length, fast decay time

**Disadvantage:** not radiation hard

Particle counting: Photomultiplier  $\rightarrow$  discriminator  $\rightarrow$  scalar  $\rightarrow$  computer

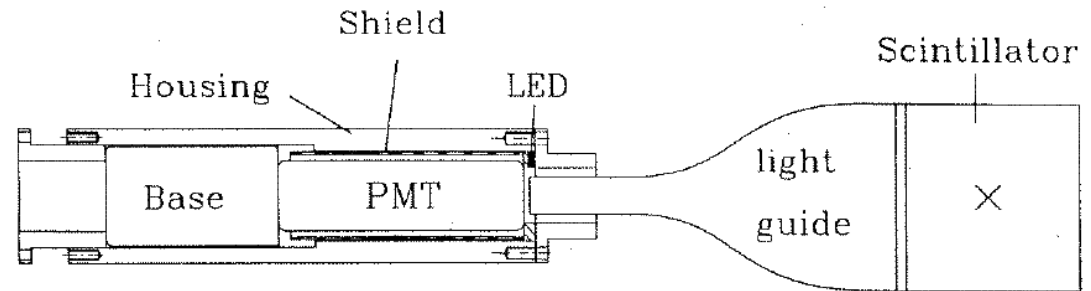

**1" Photomultiplier**

gain:  $10^6$

rise time 1.9 ns

max. **average** count rate  $3 \cdot 10^6 \text{ 1/s}$

**BC400 Scintillator**

$75 \times 75 \text{ mm}^2$

1 mm thickness

# Low Current Measurement: Particle Detectors

Electronic **solid state amplifier** have finite noise contribution

Theoretical limit:  $U_{eff} = \sqrt{4k_B \cdot R \cdot \Delta f \cdot T}$

Signal-to-Noise ratio limits the minimal detectable current

**Idea:** Amplification of single particles with photo-multiplier, sec. e<sup>-</sup> multiplier or MCPs and particle counting typically up to  $\approx 10^6$  1/s

Scheme of a photo-multiplier:

- Photon hits photo cathode
- Secondary electrons are acc. to next dynode  $\Delta U \approx 100$  V
- Typ. 10 dynodes  $\Rightarrow 10^6$  fold amplification

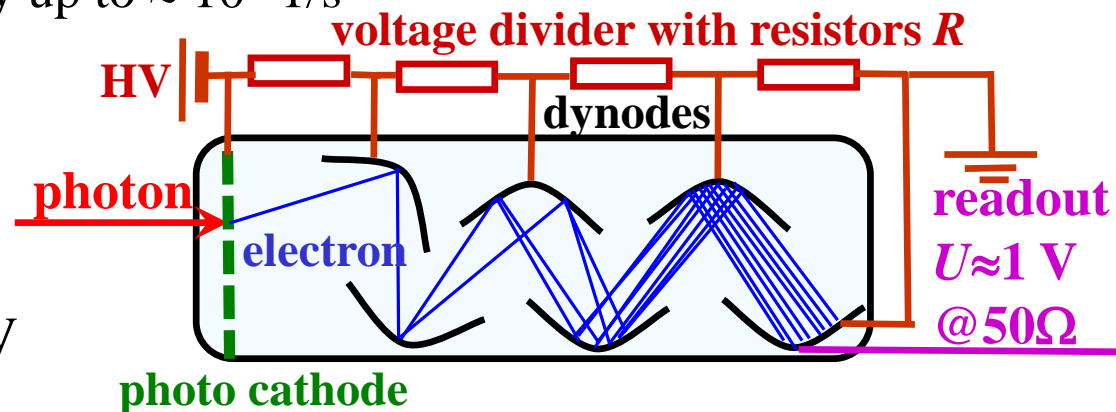

**Advantage:** no thermal noise due to electro static acceleration  
Typical 1 V signal output



# Properties of a good Scintillator

## Properties of a good scintillator:

- Light output linear to energy loss
- Fast decay time → high rate
- No self-absorption
- Wave length of fluorescence  
 $350 \text{ nm} < \lambda < 500 \text{ nm}$
- Index of refractivity  $n \approx 1.5$   
→ light-guide
- Radiation hardness  
e.g. Ce-activated inorganic  
are much more radiation hard.

Analog pulses from a plastic sc. with a low current 300 MeV/u Kr beam.

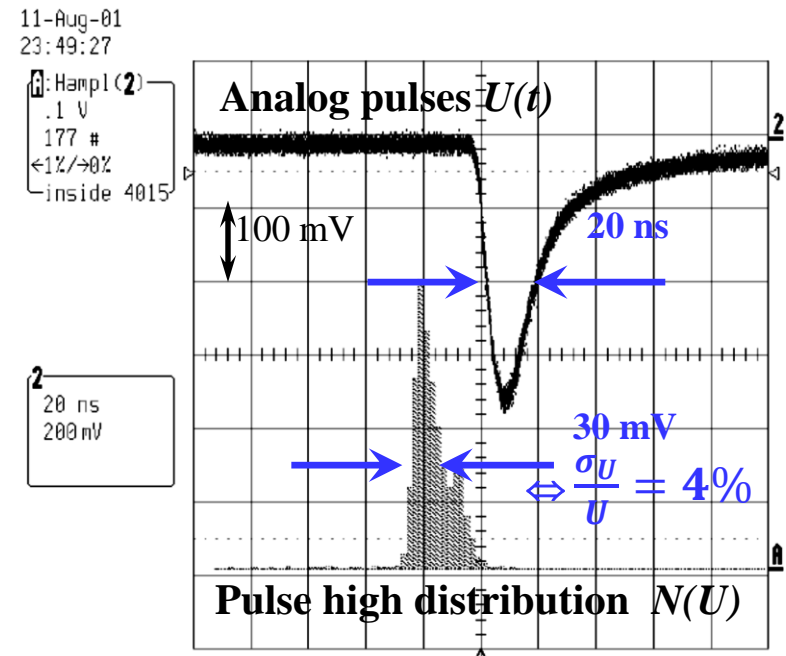

The scaling is 20 ns/div and 100 mV/div.

# Monitoring of Slow Extraction

Slow extraction from a synchrotron delivers countable currents

**Example:** Comparison for different detector types:

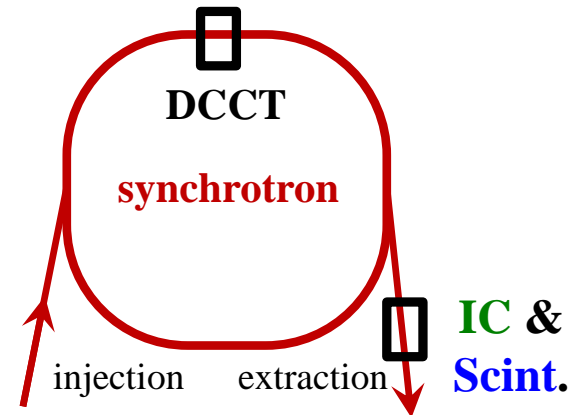
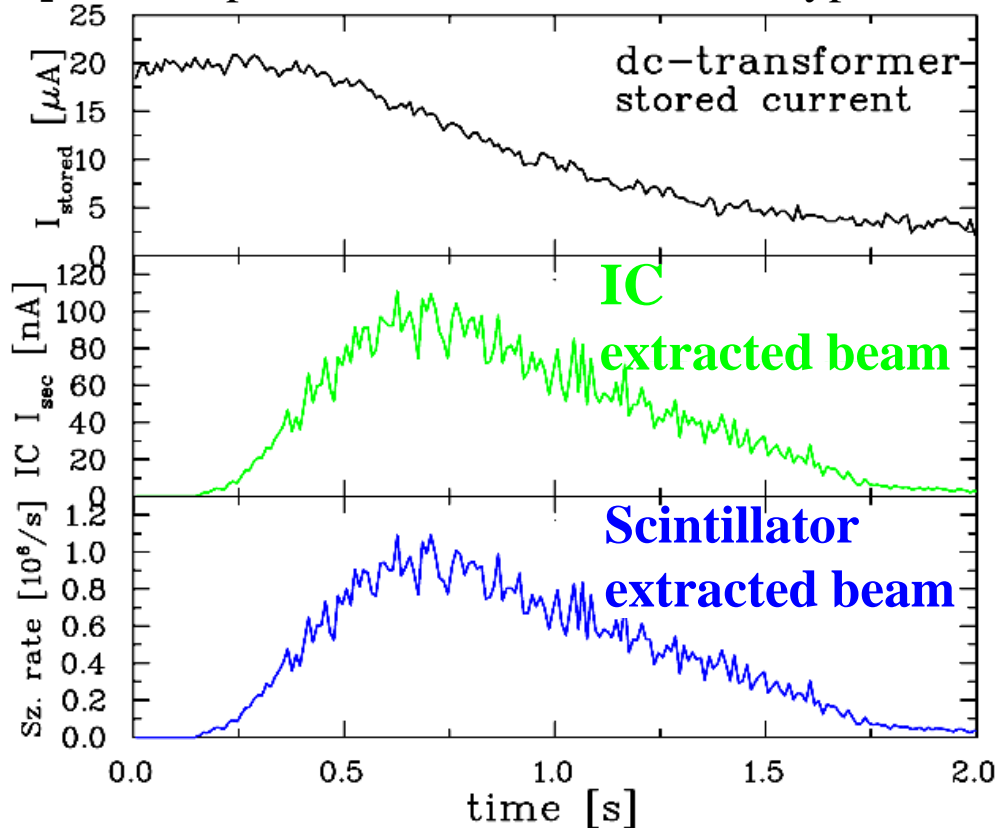

Parameters: dc-transformer inside the synch., ionization chamber and scintillator for a 250 MeV/u  $\text{Pb}^{67+}$  beam with a total amount of  $10^6$  particles.

# Ionization Chamber (IC): Electron Ion Pairs

Energy loss of charged particles in gases → electron-ion pairs → low current meas.

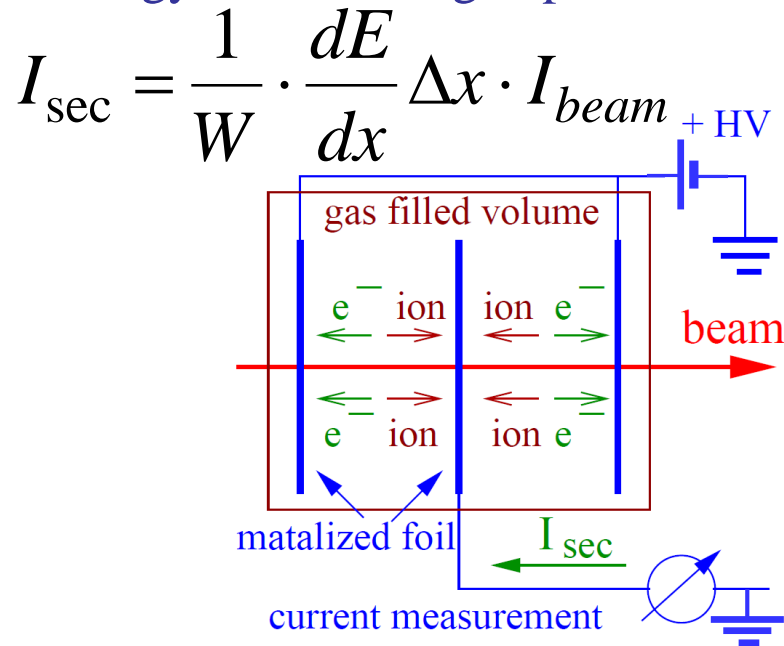

*Example: GSI type:*

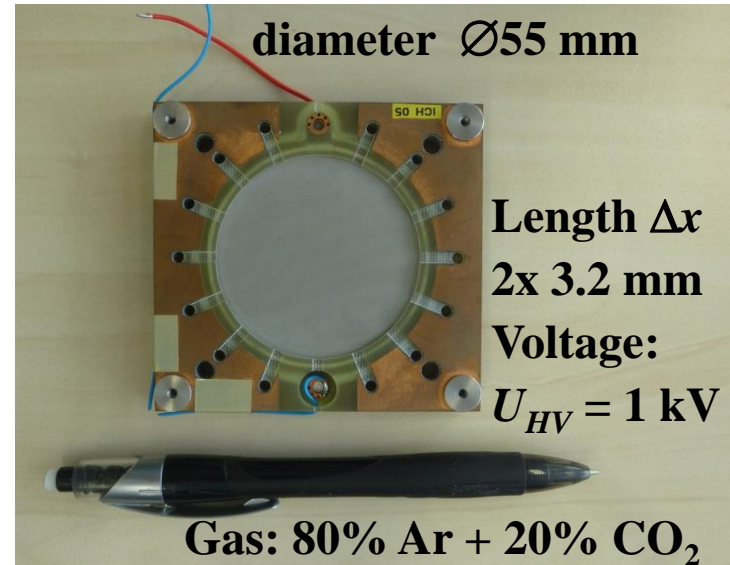

### W-value

is the average energy for one e<sup>-</sup>-ion pair:

Gas	Ionization Pot.	W-value
He	24.5 eV	42.7 eV
N <sub>2</sub>	15.5 eV	36.4 eV
O <sub>2</sub>	12.5 eV	32.2 eV
Ar	15.7 eV	26.3 eV
CO <sub>2</sub>	13.7 eV	33.0 eV

### GSI realization:

- Energy calculation  $dE/dx$  with SRIM or LISE
- Current measurement via current-to-frequency converter IFC

# Secondary Electron Monitor (SEM): Electrons from Surface

For higher intensities SEMs are used.

Due to the energy loss, secondary  $e^-$  are emitted from a metal surface.

The amount of secondary  $e^-$  is proportional to the energy loss

$$I_{\text{sec}} = Y \cdot \frac{dE}{dx} \cdot I_{\text{beam}}$$

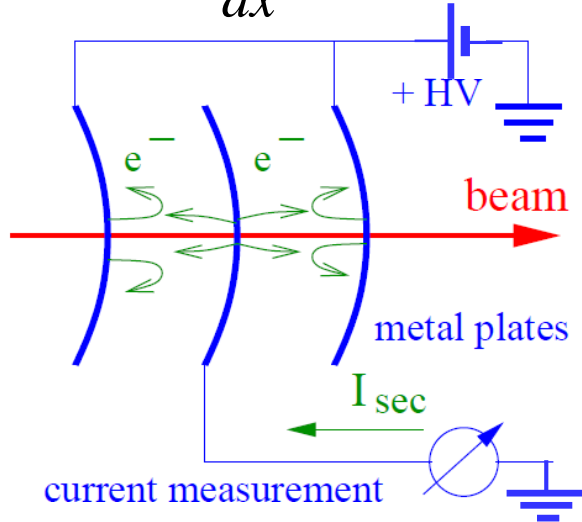

Example: GSI SEM type:

Material	Pure Al (99.5%)
# electrodes	3
Active surface	80 x 80 mm <sup>2</sup>
Distance between electrodes	5 mm
Applied voltage	+ 100
CO <sub>2</sub>	13.7 eV

**Advantage for Al:** good mechanical properties.

**Disadvantage:** Surface effect!

e.g. decrease of yield  $Y$  due to radiation

⇒ calibration versus IC required to reach 5%.

It is a *surface* effect:

→ Sensitive to cleaning procedure

→ Possible surface modification by radiation

Sometimes they are installed permanently in front of an experiment.



# GSI Installation for SEM, IC and Scintillator

SEM in vacuum

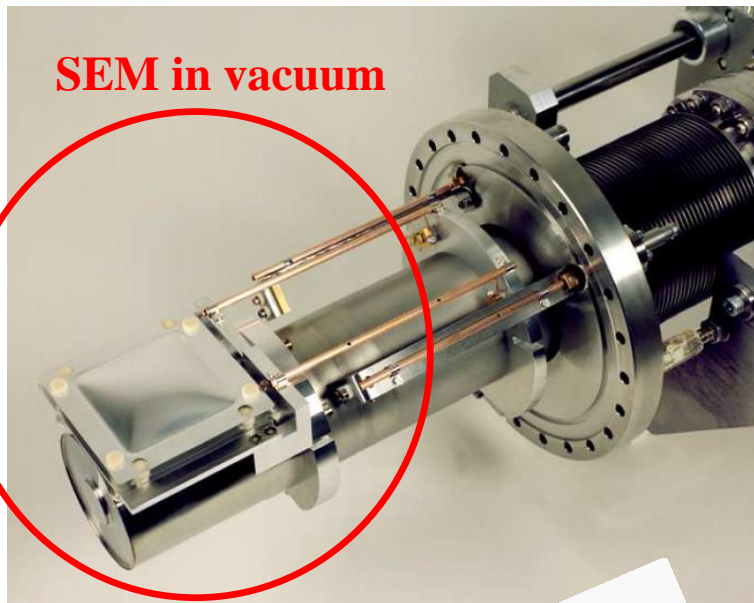

IC in Ar-gas at 1 bar

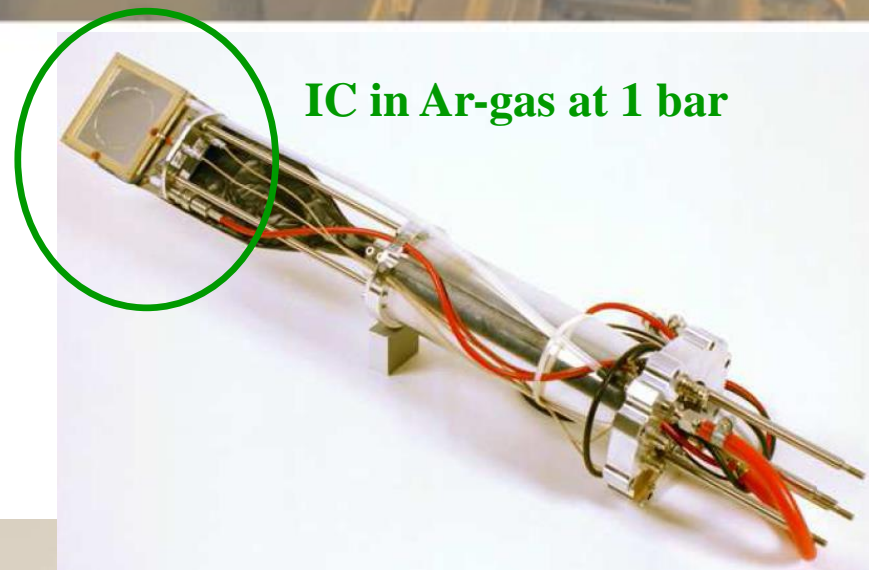

beam

SEM

gas filled

PMT

Scintillator

IC

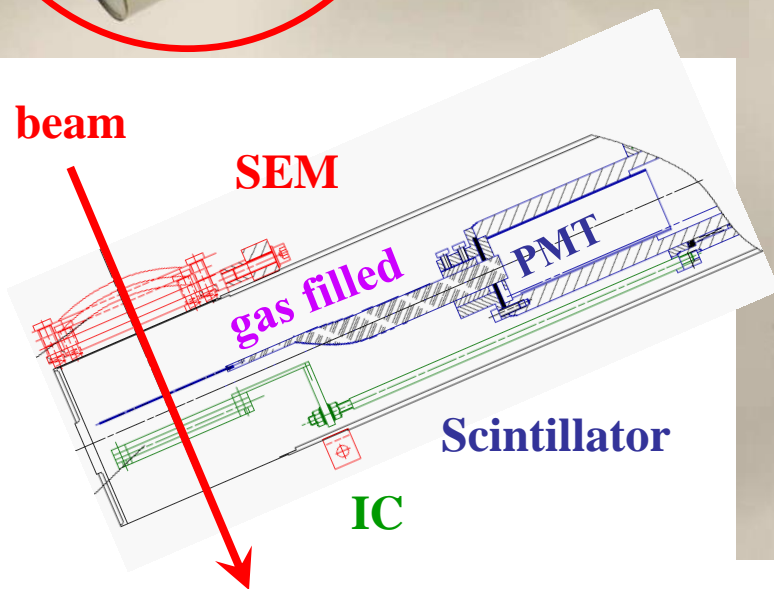

Feed-through with  
Ø 200 mm flange

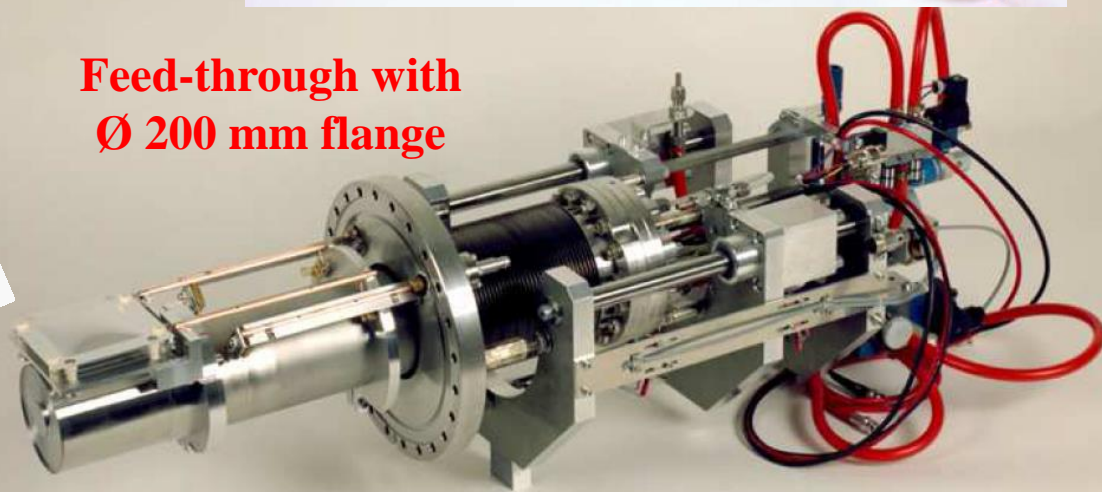

P. Forck et al., DIPAC'97

# Summary for Current Measurement

## Current is the basic quantity for accelerators!

### *Transformer:* → measurement of the beam's magnetic field

- magnetic field is guided by a high  $\mu$  toroid
- types: passive (large bandwidth), active (low droop) and dc (two toroids + modulation)
- lower threshold by magnetic noise: about  $I_{beam} > 1 \mu\text{A}$
- non-destructive, used for all beams

### *Faraday cup:* → measurement of beam's charge

- low threshold by I/U-converter:  $I_{beam} > 10 \text{ pA}$
- totally destructive, used for low energy beams

### *Scintillator,* → measurement of the particle's energy loss

### *IC, SEM:*

- particle counting (Scintillator)
- secondary current: **IC** from gas ionization or **SEM** sec.  $e^-$  emission surface
- no lower threshold due to single particle counting
- partly destructive, used for high energy beams

# Appendix: GSI Heavy Ion Research Center

## German national heavy ion accelerator facility in Darmstadt

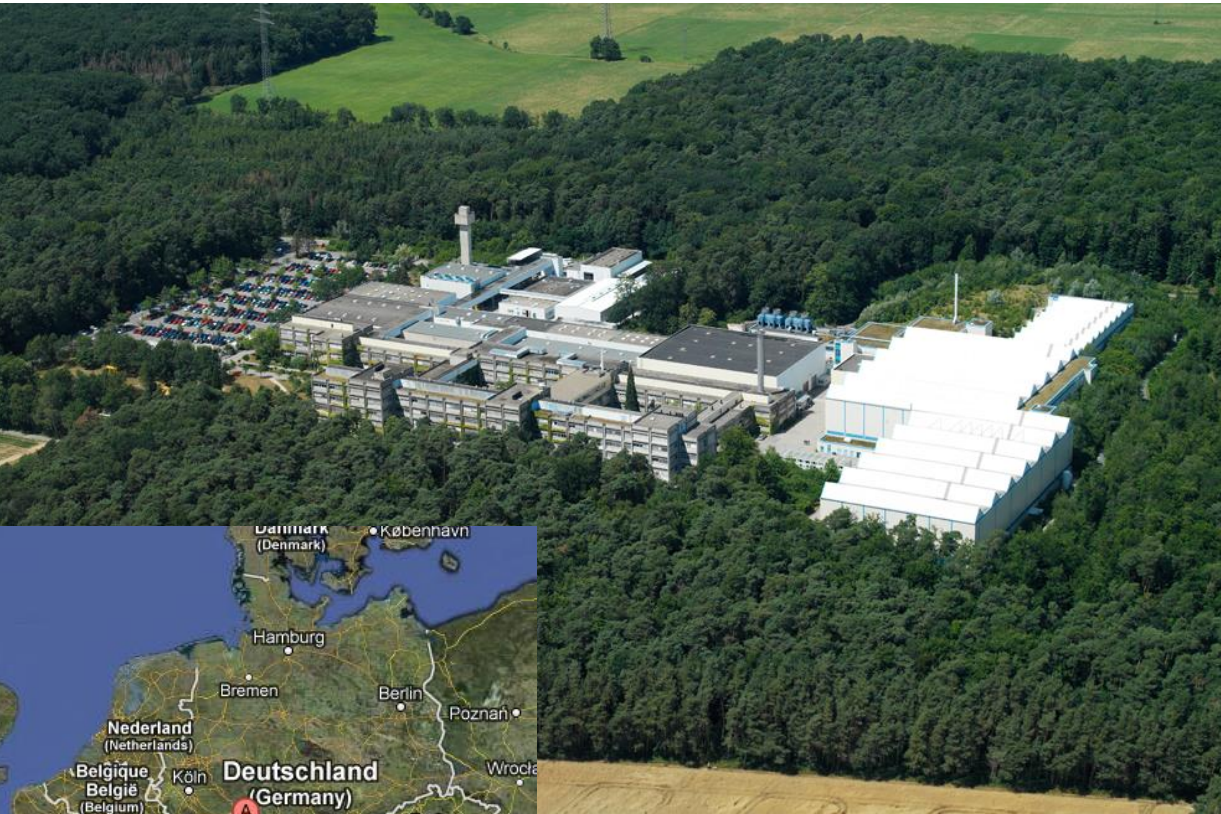

### Accelerators:

**Acceleration of all ions**

**LINAC:** up to 15 MeV/u

**Synchrotron:** up to 2 GeV/u

### Research area:

- Nuclear physics  $\approx 60\%$
- Atomic physics  $\approx 20\%$
- Bio physics (e.g. cell damage)  
incl. cancer therapy  $\approx 10\%$
- Material research  $\approx 10\%$

**Extension by  
international FAIR facility**

**GSI is one of 18 German large scale research centers.**

# Appendix: The Accelerator Facility at GSI

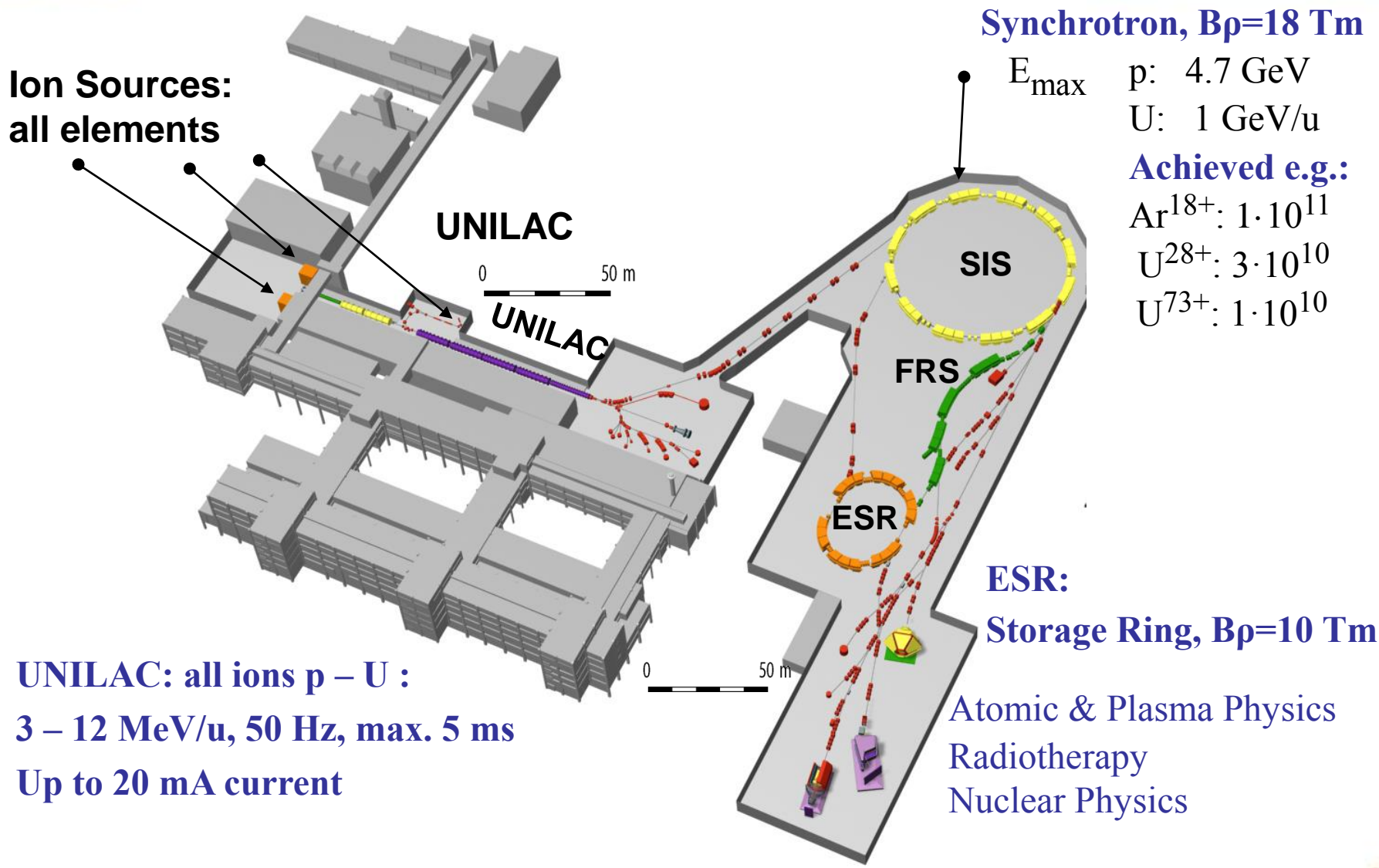

# Appendix: Beam Instruments at GSI Accelerator Facility

**Synchrotron:** Current: 2 DCCT, 1 ACCT, 1 FCT  
 Profile: 1 SEM-Grid, 1 IPM, 1 Screen  
 Position: 16 BPM  
 Tune, mom. spread: 1 Exciter + BPM  
 1 Schottky

**Ion Sources:**  
 all elements

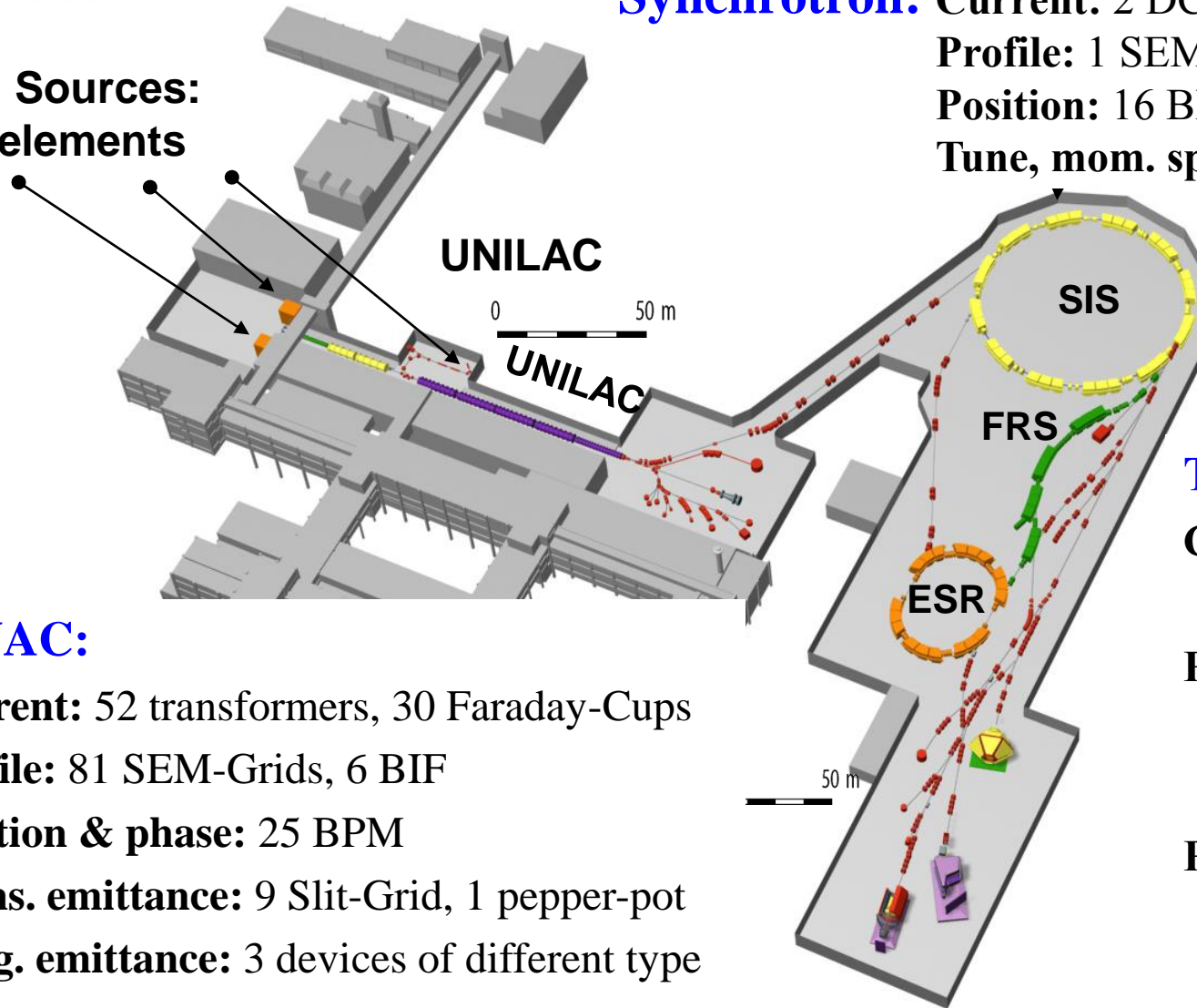

**Transport Lines:**

Current: 8 FCT  
 15 Part. Detec.  
 Profile: 10 SEM-Grid  
 26 MWPC  
 18 Screens  
 Position: 8 BPM

**LINAC:**

Current: 52 transformers, 30 Faraday-Cups  
 Profile: 81 SEM-Grids, 6 BIF  
 Position & phase: 25 BPM  
 Trans. emittance: 9 Slit-Grid, 1 pepper-pot  
 Long. emittance: 3 devices of different type

# Appendix: UNILAC at GSI: Current Measurement

 **Faraday Cup:** for low current measurement and beam stop, total 30

 **Transformer ACCT:** for current measurement and transmission control total 52 device

**They are used for alignment and interlock generation**

Transfer to Synchrotron

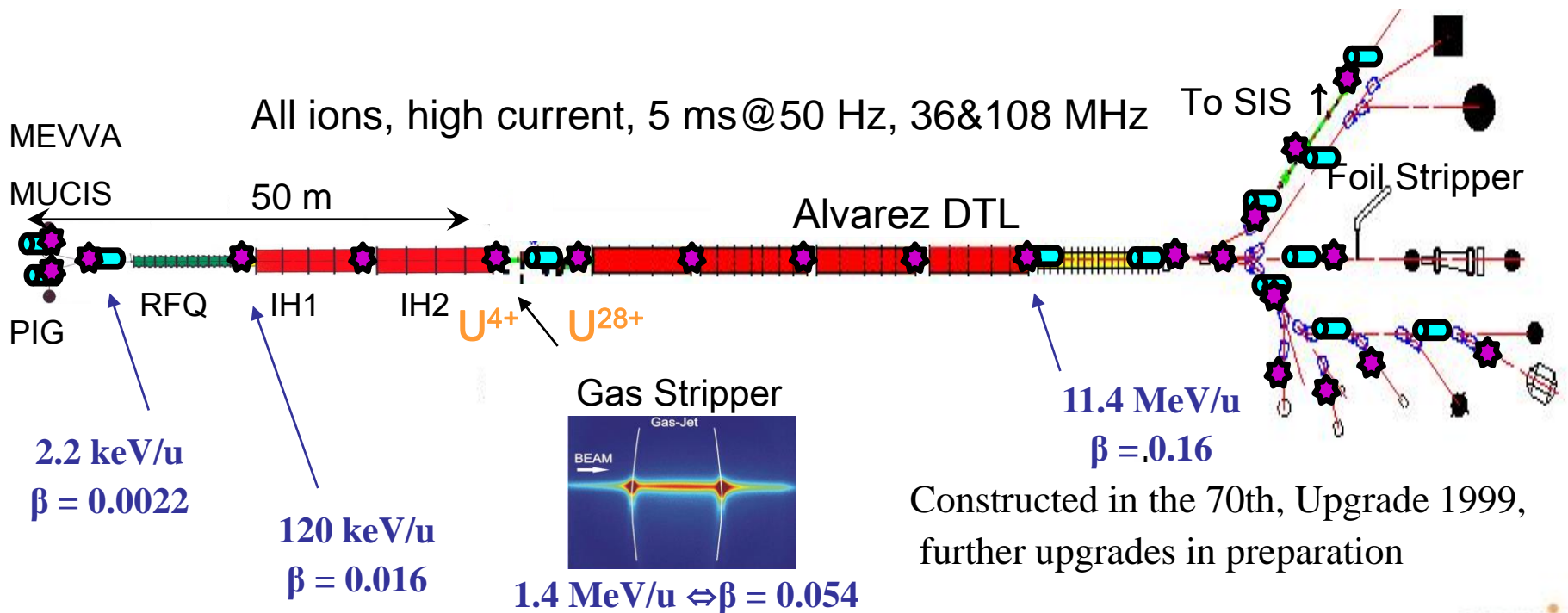

# Appendix: GSI Heavy Ion Synchrotron: Overview

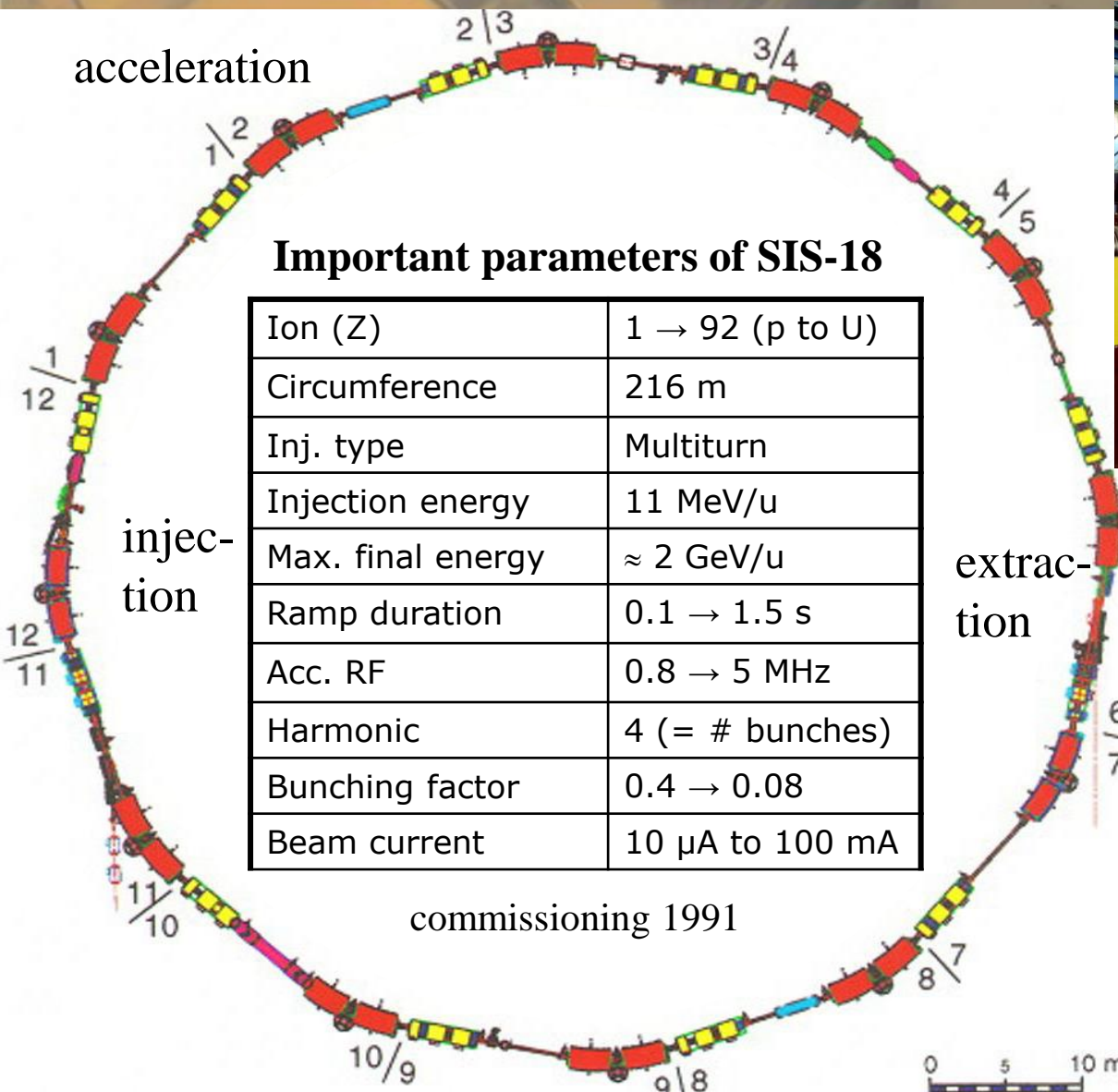

## Important parameters of SIS-18

Ion (Z)	1 → 92 (p to U)
Circumference	216 m
Inj. type	Multiturn
Injection energy	11 MeV/u
Max. final energy	≈ 2 GeV/u
Ramp duration	0.1 → 1.5 s
Acc. RF	0.8 → 5 MHz
Harmonic	4 (= # bunches)
Bunching factor	0.4 → 0.08
Beam current	10 μA to 100 mA

commissioning 1991



# Appendix: GSI Heavy Ion Synchrotron: Current Measurement

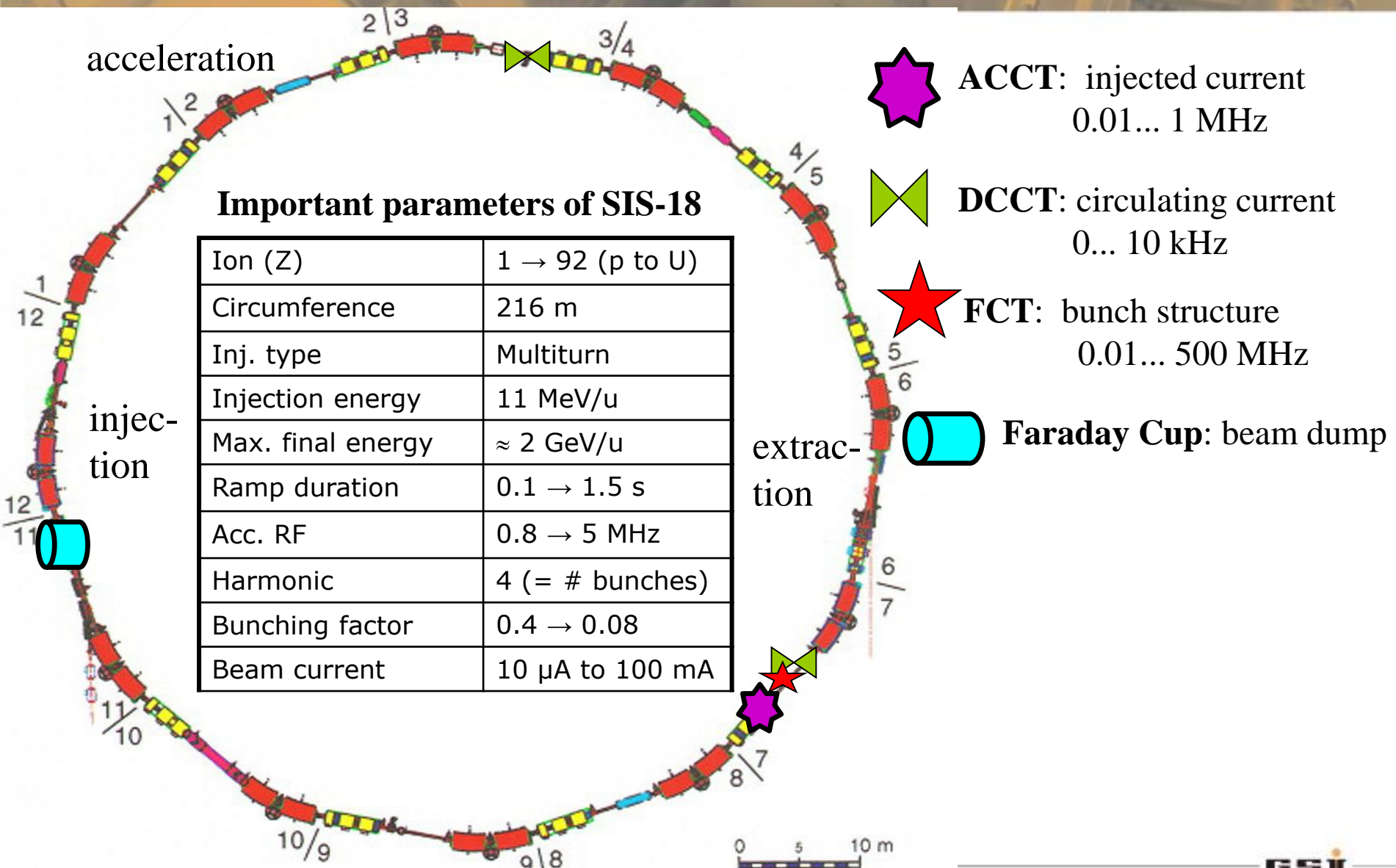

## Important parameters of SIS-18

Ion (Z)	1 → 92 (p to U)
Circumference	216 m
Inj. type	Multiturn
Injection energy	11 MeV/u
Max. final energy	≈ 2 GeV/u
Ramp duration	0.1 → 1.5 s
Acc. RF	0.8 → 5 MHz
Harmonic	4 (= # bunches)
Bunching factor	0.4 → 0.08
Beam current	10 μA to 100 mA



**ACCT:** injected current  
0.01... 1 MHz



**DCCT:** circulating current  
0... 10 kHz



**FCT:** bunch structure  
0.01... 500 MHz

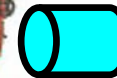

**Faraday Cup:** beam dump



# Appendix: 3<sup>rd</sup> Generation Light Sources

Soleil, Paris,  $E_{electron} = 2.5$  GeV,  $C = 354$  m

## 3<sup>rd</sup> Generation Light Sources:

Synchrotron-based

with  $E_{electron} \approx 1 \dots 8$  GeV

Light from undulators & wigglers, dipoles,  
with  $E_{\gamma} < 10$  keV (optical to deep UV)

Users in:

- Biology  
(e.g. protein crystallography)
- Chemistry  
(e.g. observation of reaction dynamics)
- material science  
(e.g. x-ray diffraction)
- Basic research in solid state and atomic physics

Unique setting: intense, broad-band light emission (monochromator for wavelength selection)

**National facilities in many countries, some international facilities.**

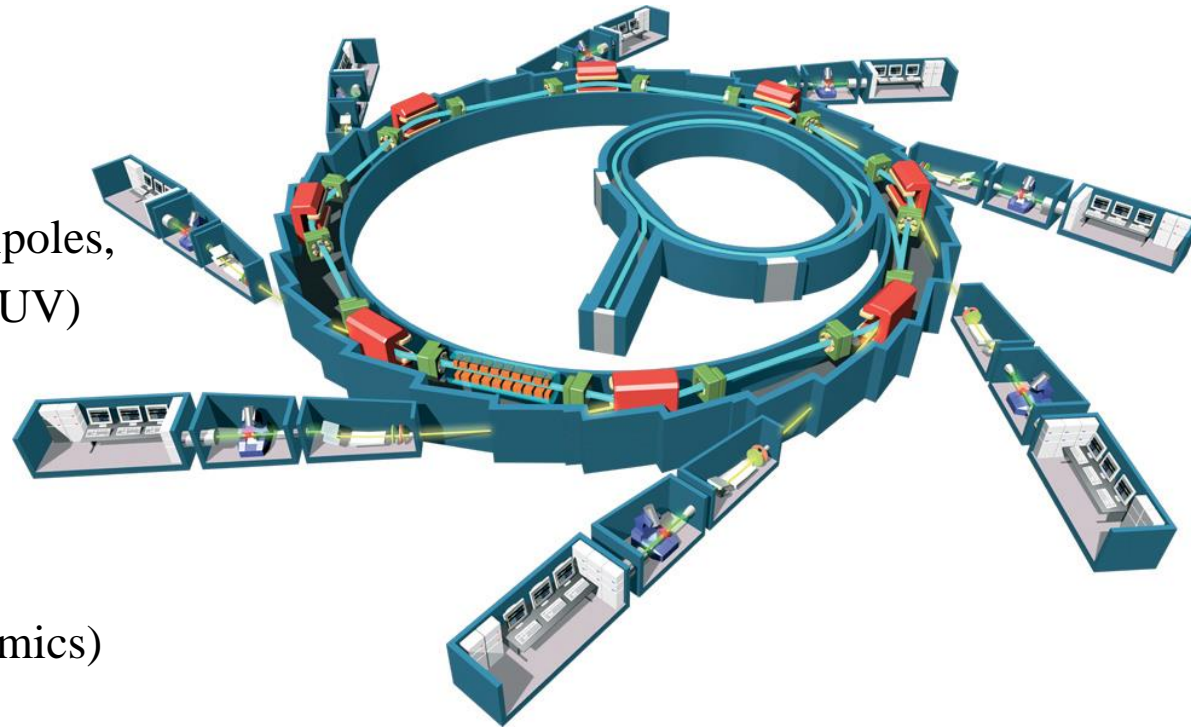

# Appendix: The Spanish Synchrotron Light Facility ALBA

## 3<sup>rd</sup> generation Spanish national synchrotron light facility in Barcelona



### Layout:

Beam lines: up to 30  
 Electron energy: 3 GeV  
 Top-up injection  
 Storage ring length: 268 m  
 Max. beam current: 0.4 A  
 Commissioning in 2011



Talk by Ubaldo Iriso: at DIPAC 2011, [adweb.desy.de/mpy/DIPAC2011/html/session.htm](http://adweb.desy.de/mpy/DIPAC2011/html/session.htm)

see also [www.cells.es/Divisions/Accelerators/RF\\_Diagnostics/Diagnostics](http://www.cells.es/Divisions/Accelerators/RF_Diagnostics/Diagnostics)

# Appendix: The Spanish Synchrotron Light Facility ALBA: Overview

## 3<sup>rd</sup> generation Spanish national synchrotron light facility in Barcelona

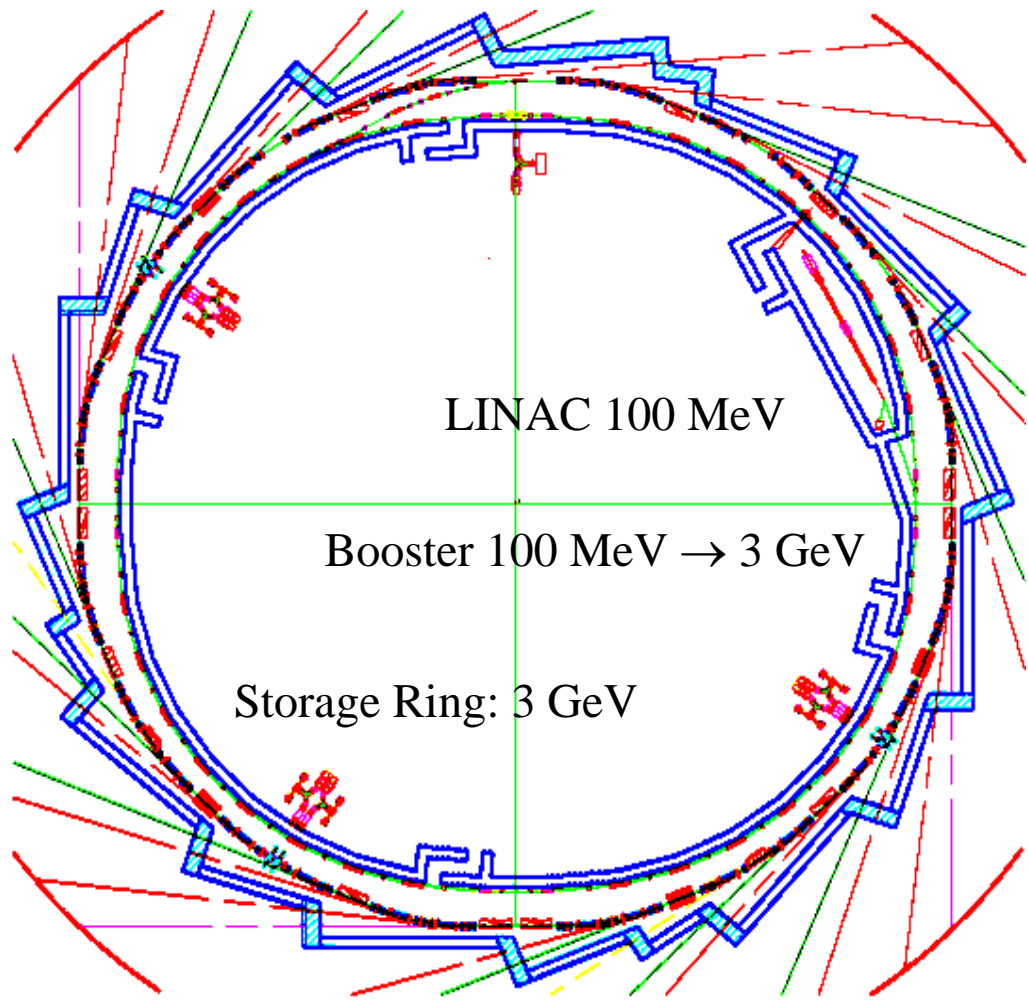

### Layout:

- Beam lines: up to 30
- Electron energy: 3 GeV
- Top-up injection
- Storage ring length: 268 m
- Max. beam current: 0.4 A
- Commissioning in 2011

From U. Iriso, ALBA

# Appendix: The Synchrotron Light Facility ALBA: Current Meas.

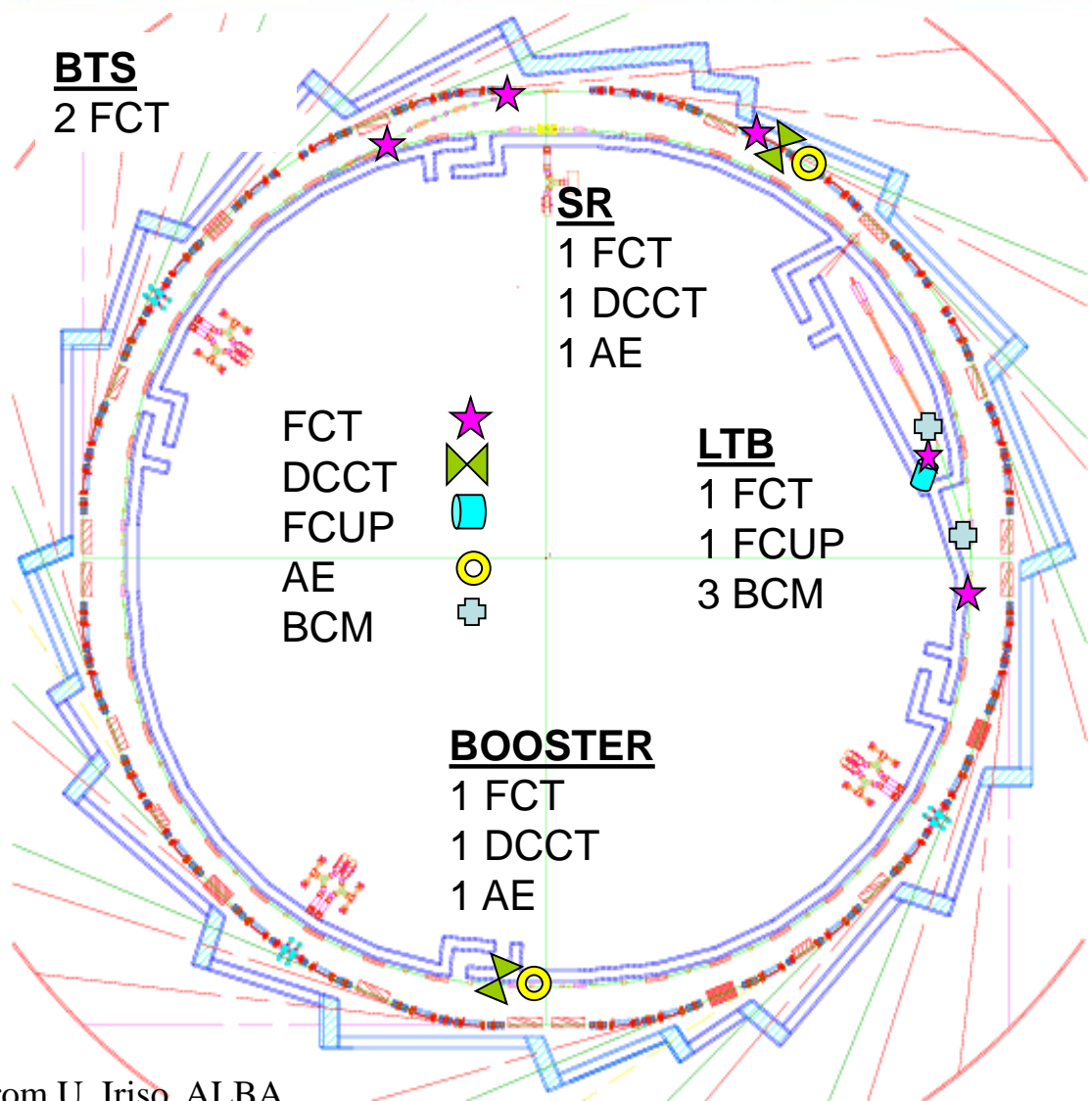

## Beam current:

Amount of electrons accelerated, transported and stored

- Several in transport lines
- One per ring

## Abbreviation:

- FCT:** Fast Current Transformer
- DCCT:** dc transformer
- FCUP:** Faraday Cup
- AE:** Annular Electrode
- BCM:** Bunch Charge Monitor

## Remark:

AE: Annular Electrode  
i.e. circular electrode acting like a high frequency pick-up

From U. Iriso, ALBA

# Energy Loss of Ions in Copper

Bethe Bloch formula: 
$$-\frac{dE}{dx} = 4\pi N_A r_e m_e c^2 \cdot \frac{Z_t}{A_t} \rho_t \cdot \frac{Z_p^2}{\beta^2} \left( \ln \frac{2m_e c^2 \gamma^2 \beta^2}{I} - \beta^2 \right)$$

Range: 
$$R = \int_0^{E_{\max}} \left( \frac{dE}{dx} \right)^{-1} dE$$

with approx. scaling  $R \propto E_{\max}^{1.75}$

## This is an atomic physics process:

1. Projectile ions liberates fast electrons
  2. Thermalization by collisions with further electrons
  3. Transfer of energy to lattice (phonon)
- ⇒ **heating of target**

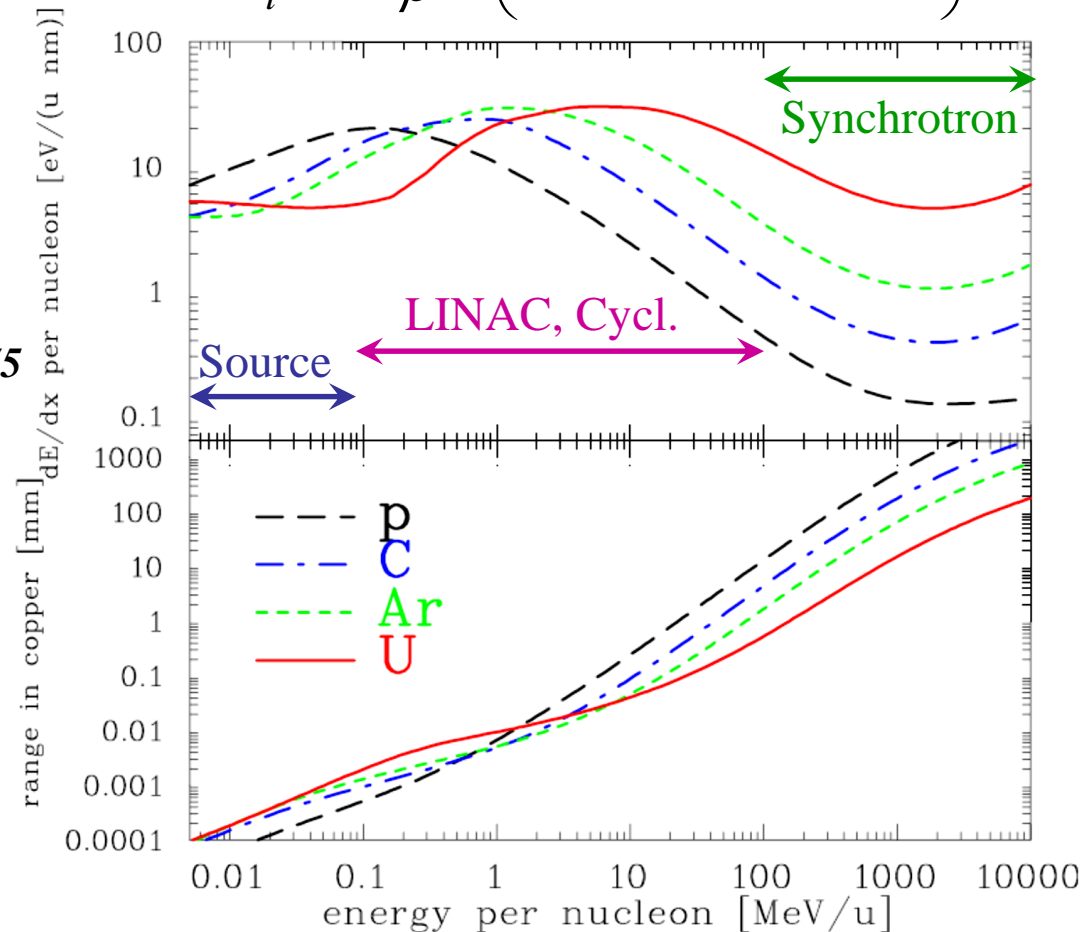

# Faraday Cups for high Intensity Ion Beam → Surface Heating

The heating of material has to be considered, given by the energy loss.

The cooling is done by radiation due to Stefan-Boltzmann:  $P_r = \epsilon \sigma T^4$

**Example:** Beam current: 11.4 MeV/u Ar<sup>10+</sup> with 10 mA and 1 ms beam delivery

Beam size: 5 mm FWHM → 23 kW/mm<sup>2</sup>,  $P_{peak} = 450$  kW total power during 1ms delivery

Foil: 1 μm Tantalum, emissivity  $\epsilon = 0.49$

Temperature increase:

T > 2000 °C during beam delivery

Even for low average power,  
the material should  
survive the peak power!

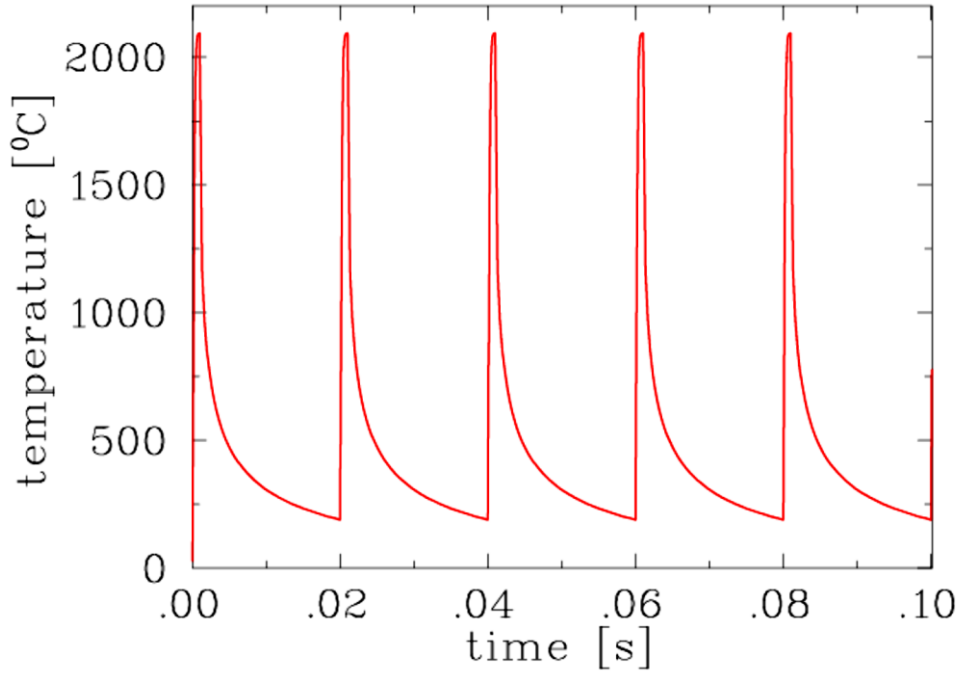

# High Power Faraday Cups

Cups designed for 1 MW, 1 ms pulse power → cone of Tungsten-coated Copper

Bismuth for high melting temperature and copper for large head conductivity.

