



Version 10.5

Visualization I.

Mihaly Novak (CERN, EP-SFT)

based on materials provided by: M. Asai (SLAC), J. Perl (SLAC), L. Garnier (CNRS)

Geant4 beginners course at CERN, Geneva (Switzerland), 22-23 January 2019

- What can be visualized?
- Type of visualization drivers
- Qt GUI with OpenGL driver
- Hands-On
- (Movies)
- Questions

Visualization I.

WHAT CAN BE VISUALIZED?

- **Simulation data:**
 - geometrical components, detector, simulation set-up
 - particle trajectories and their tracking steps
 - hits of particles in the geometry or
 - quantities like energy deposit, dose, etc.
- **User defined objects** (not directly related to the simulation itself):
 - polylines (connected lines as an object): e.g. coordinate axes
 - 3D markers: e.g. eye guides
 - text:
 - descriptive character strings (e.g. some dynamic properties during tracking)
 - comments or titles
- **Geant4 visualization documentation:** [Visualization Documentation](#)

Visualization I.

TYPE OF VISUALIZATION DRIVERS

A variety of choices depending on the requirements:

Driver	Variant	Hight quality print	Interactive	browse geometry hierarchies	Direct access to G4 kernel	Make movies	Web
OpenGL	X	Green	Green	Red	Green	Green	Red
	Xm	Green	Green	Red	Green	Green	Red
	Qt	Green	Green	Green	Green	Green	Red
	Win32	Green	Green	Red	Green	Green	Red
OpenInventor	Xt	Green	Green	Red	Green	Red	Red
	Win32	Green	Green	Red	Green	Red	Red
DAWN		Green	Red	Red	Red	Red	Red
VRML		Red	Green	Red	Red	Red	Green
HepRep		Red	Green	Green	Red	Red	Red
gMocren		Red	Green	Red	Red	Red	Red
RayTracer		Green	Red	Red	Red	Red	Red
ACSII File		Red	Red	Green	Green	Red	Red

Comput. Phys. Comm. 178 (2008) 331-365

- From **controlling** point of view:
 - some visualization drivers work **directly from Geant4**:
 - OpenGL, OpenInventor, RayTracer, ASCII Tree
 - for other visualization drivers, **a (special) file** must be **first produced by Geant4** then this file will be **rendered by another application**:
 - HepRep, DAWN, VRML, gMocren
- The Geant4 code stays basically the same independently from the choice of the driver
- Visualization is performed either with commands or from C++ code
 - for the present tutorial, we confine ourselves to **command-driven** visualization (both in interactive and batch modes)

- Availability of drives:
 - six of the visualization drivers are always included by default (since they require no external libraries):
 - RayTracer, ASCIITree, HepRep, DAWN, VRML, gMocren
 - other visualization drives (e.g. OpenGL, OpenInventor) will be included only if they were explicitly required during the Geant4 build (through ***cmake*** using the appropriate ***cmake option***):
 - `-DGEANT4_USE_OPENGL_X11=ON` OpenGL visualization driver with X11 window
 - `-DGEANT4_USE_QT=ON` Qt GUI with OpenGL visualization driver
 - in all cases some headers and libraries (X11, Qt, OpenGL or MesaGL) need to be available on the system
 - on your virtual machine, Geant4 is available with Qt GUI and OpenGL support

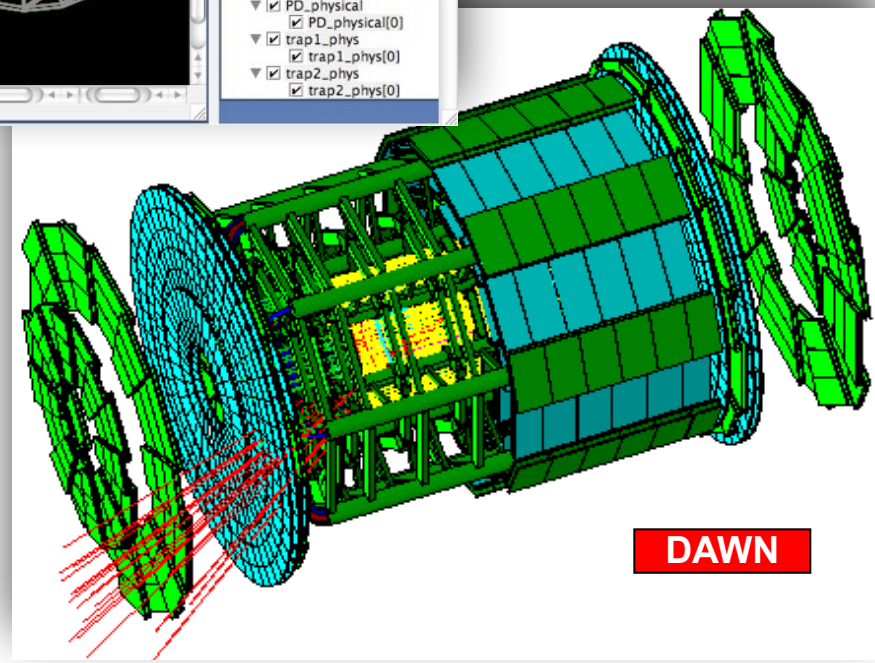
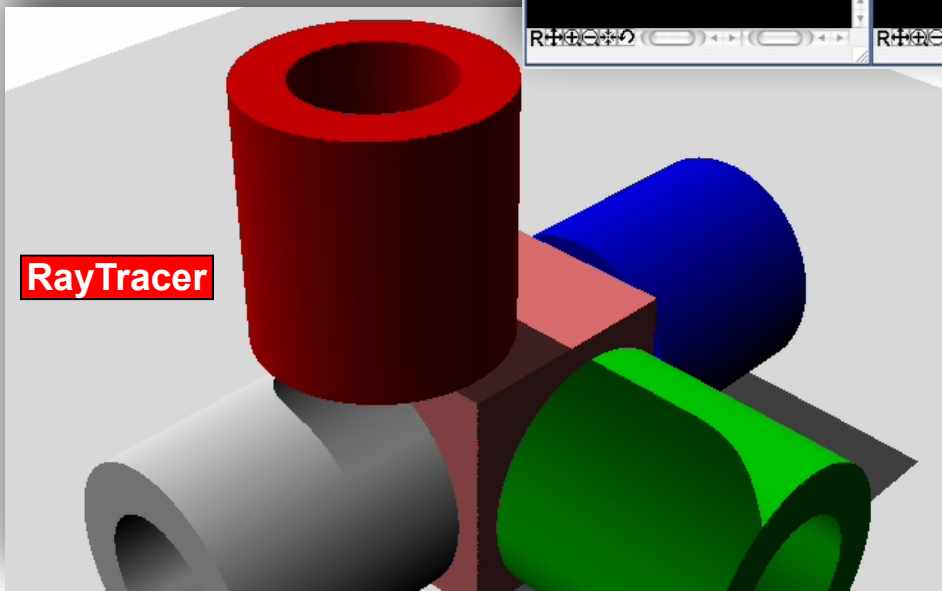
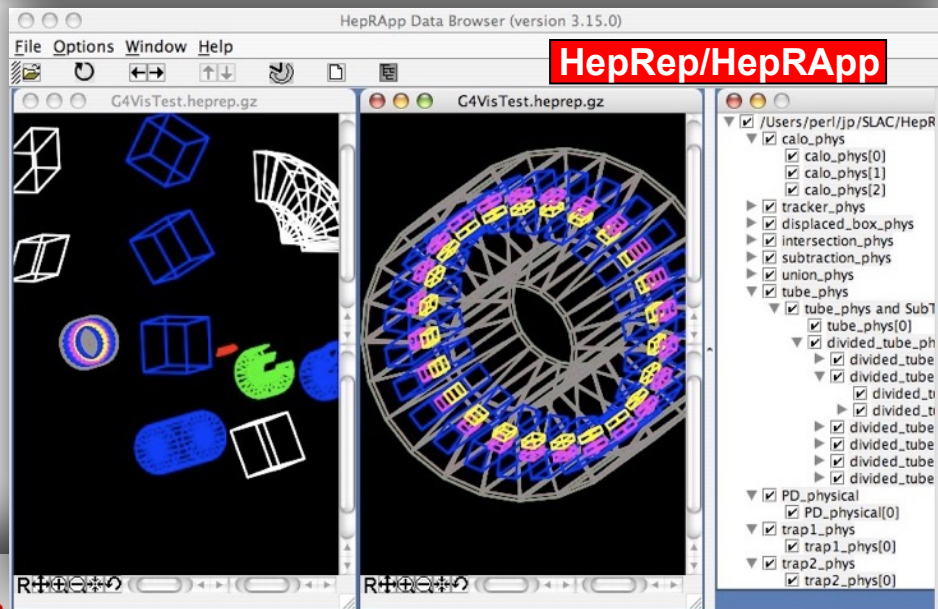

Type of visualization drivers

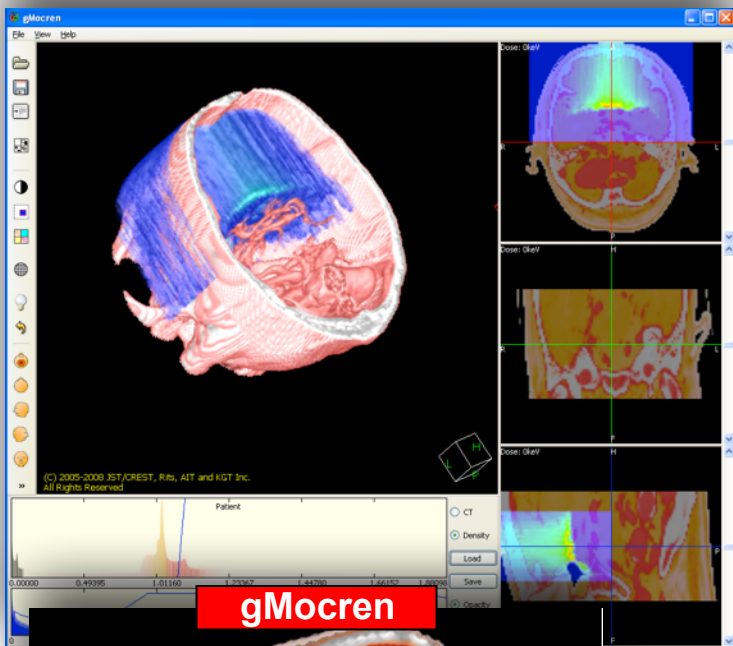

gMocren

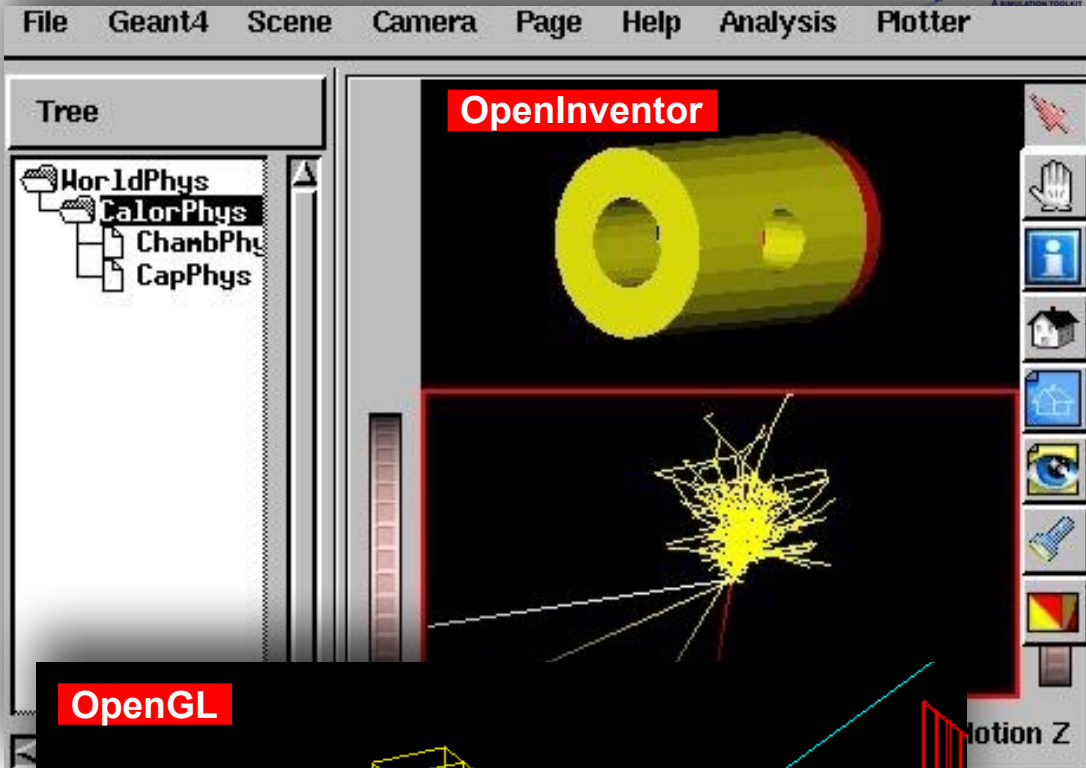

OpenInventor

OpenGL

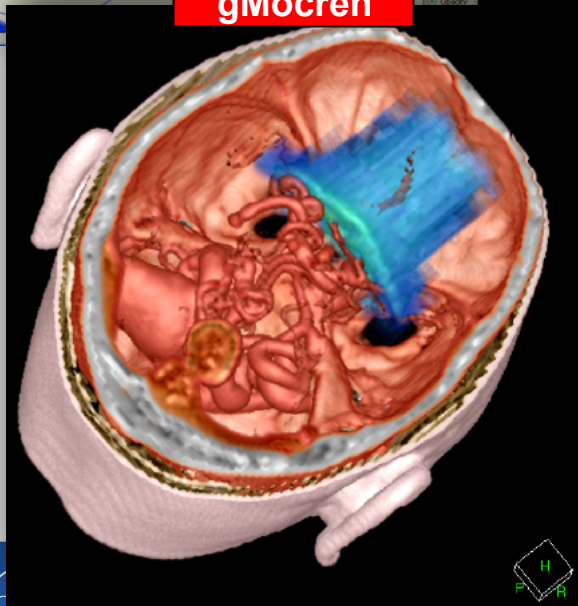

Qt GUI with OpenGL visualization driver:

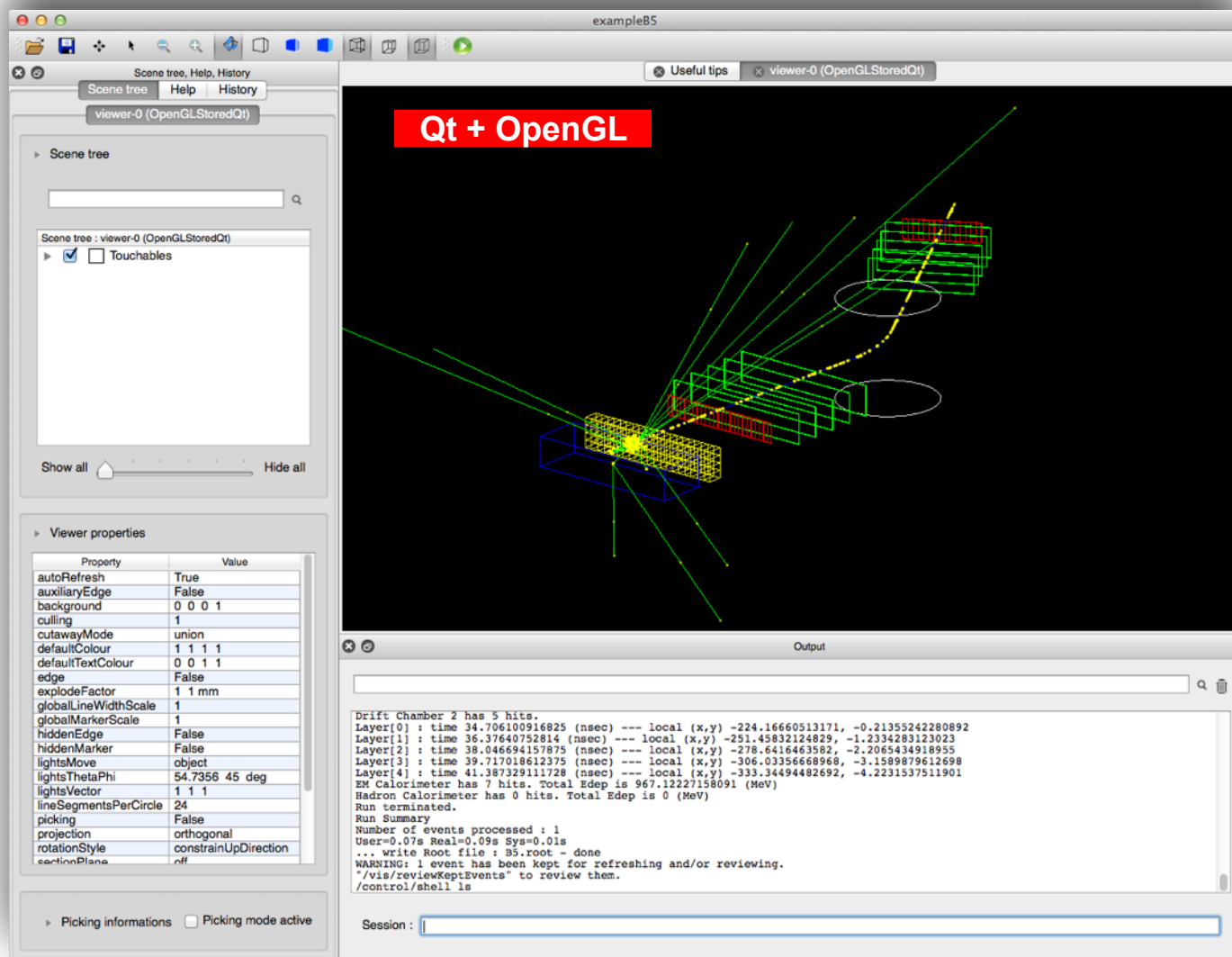

Visualization I.

QT GUI WITH OPENGL DRIVER

Qt GUI with OpenGL visualization driver:

- recent developments focused on this combination
- documentation is available at [Qt+OpenGL](#)
- Geant4 OpenGL tutorial with commands [here](#)
- to visualize the geometry:
 - `/vis/open OGL`
 - `/vis/drawVolume`
- most of the Geant4 examples comes with a visualization macro (`vis.mac`)
- let's see ours (in example B1) so start the Hands-On

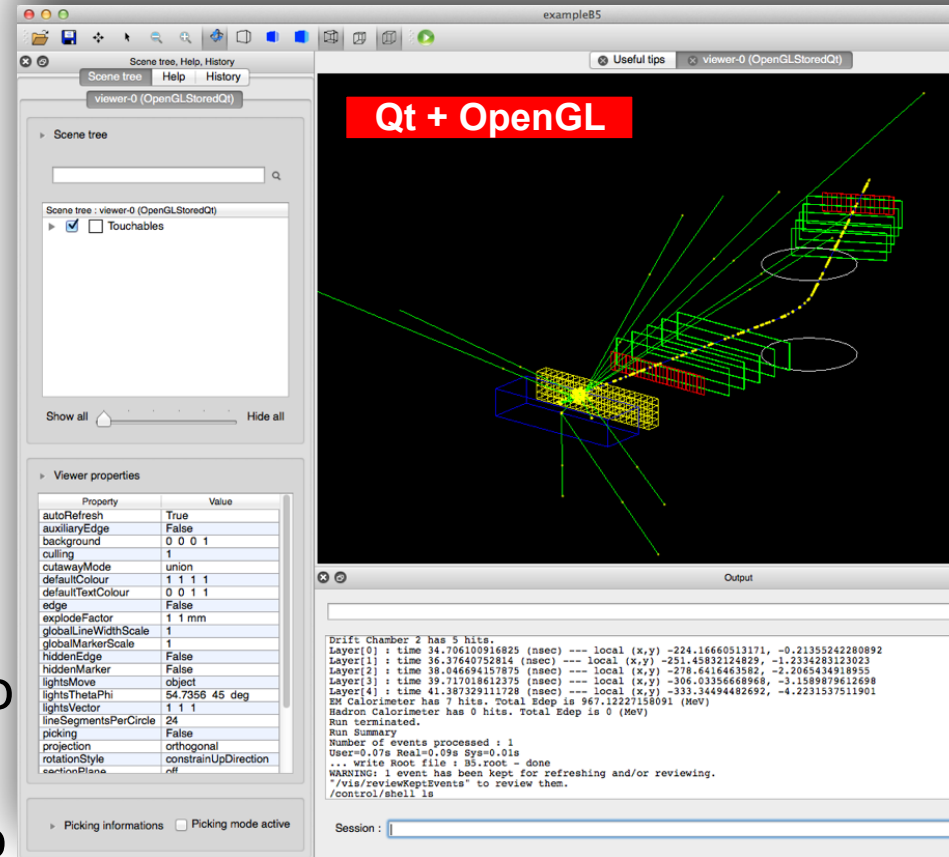

Scene tree, Help, History

viewer-0 (OpenGLStoredQt)

Scene tree

Search:

Scene tree : viewer-0 (OpenGLStoredQt)

- Touchables

Show all Hide all

Viewer properties

Property	Value
autoRefresh	True
auxiliaryEdge	False
background	0 0 0 1
culling	1
cutawayMode	union
defaultColour	1 1 1 1
defaultTextColour	0 0 1 1
edge	False
explodeFactor	1 1 mm
globalLineWidthScale	1
globalMarkerScale	1
hiddenEdge	False
hiddenMarker	False
lightsMove	object
lightsThetaPhi	54.7356 45 deg
lightsVector	1 1 1
lineSegmentsPerCircle	24
picking	False
projection	orthogonal
rotationStyle	constrainUpDirection
sectionPlane	off

Picking informations Picking mode active

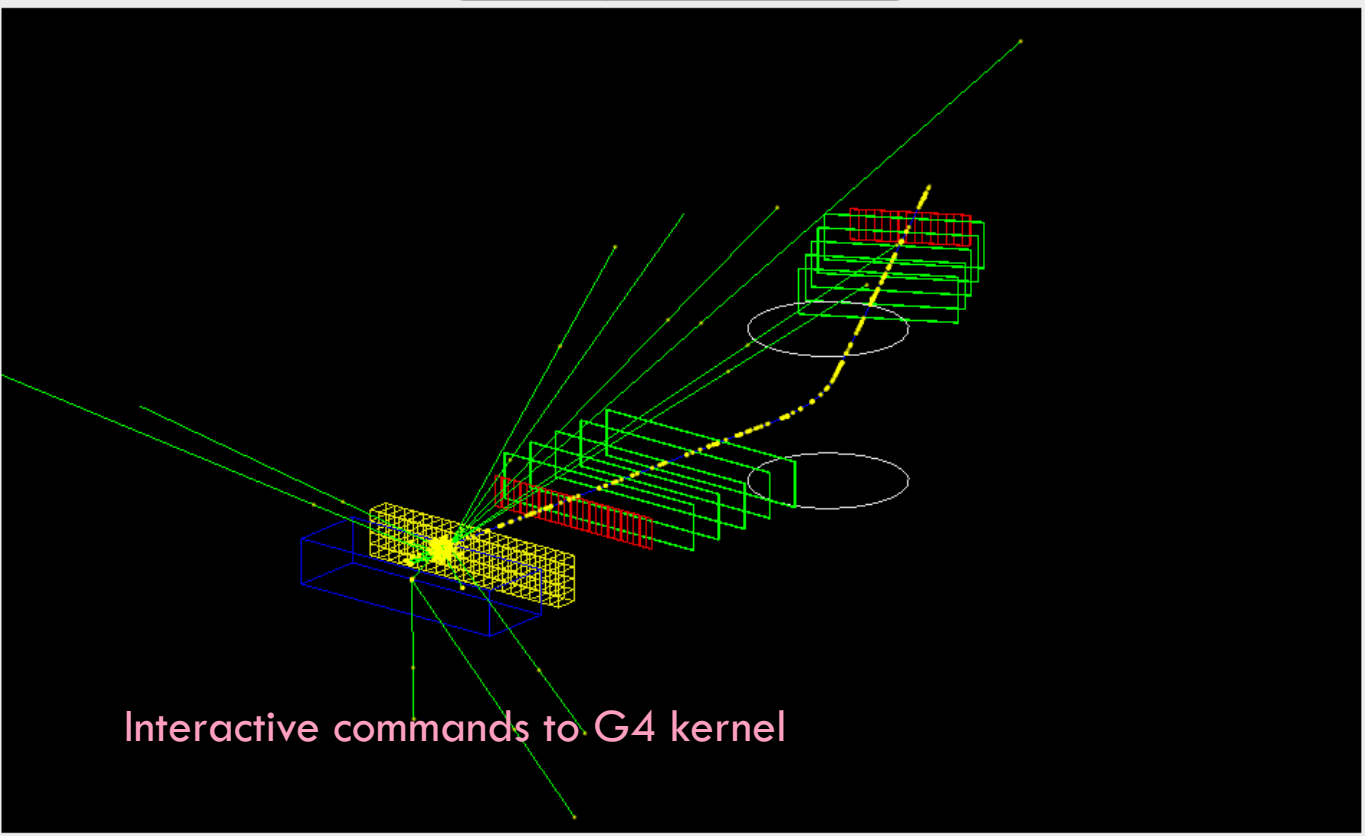

Interactive commands to G4 kernel

Output

```

Drift Chamber 2 has 5 hits.
Layer[0] : time 34.706100916825 (nsec) --- local (x,y) -224.16660513171, -0.21355242280892
Layer[1] : time 36.37640752814 (nsec) --- local (x,y) -251.45832124829, -1.2334283123023
Layer[2] : time 38.046694157875 (nsec) --- local (x,y) -278.6416463582, -2.2065434918955
Layer[3] : time 39.717018612375 (nsec) --- local (x,y) -306.03356668968, -3.1589879612698
Layer[4] : time 41.387329111728 (nsec) --- local (x,y) -333.34494482692, -4.2231537511901
EM Calorimeter has 7 hits. Total Edep is 967.12227158091 (MeV)
Hadron Calorimeter has 0 hits. Total Edep is 0 (MeV)
Run terminated.
Run Summary
Number of events processed : 1
User=0.07s Real=0.09s Sys=0.01s
... write Root file : B5.root - done
WARNING: 1 event has been kept for refreshing and/or reviewing.
"/vis/reviewKeptEvents" to review them.
/control/shell ls

```

Session :

Scene tree, Help, History

viewer-0 (OpenGLStoredQt)

Scene tree

viewer-0 (OpenGLStoredQt)

Scene tree : viewer-0 (OpenGLStoredQt)

Touchables

Show all Hide all

Viewer properties

Property	Value
autoRefresh	True
auxiliaryEdge	False
background	0 0 0 1
culling	1
cutawayMode	union
defaultColour	1 1 1 1
defaultTextColour	0 0 1 1
edge	False
explodeFactor	1 1 mm
globalLineWidthScale	1
globalMarkerScale	1
hiddenEdge	False
hiddenMarker	False
lightsMove	object
lightsThetaPhi	54.7356 45 deg
lightsVector	1 1 1
lineSegmentsPerCircle	24
picking	False
projection	orthogonal
rotationStyle	constrainUpDirection
sectionPlane	off

Picking informations Picking mode active

Useful tips viewer-0 (OpenGLStoredQt)

Output from G4 kernel (support for search, MT)

Output

```

Drift Chamber 2 has 5 hits.
Layer[0] : time 34.706100916825 (nsec) --- local (x,y) -224.16660513171, -0.21355242280892
Layer[1] : time 36.37640752814 (nsec) --- local (x,y) -251.45832124829, -1.2334283123023
Layer[2] : time 38.046694157875 (nsec) --- local (x,y) -278.6416463582, -2.2065434918955
Layer[3] : time 39.717018612375 (nsec) --- local (x,y) -306.03356668968, -3.1589879612698
Layer[4] : time 41.387329111728 (nsec) --- local (x,y) -333.34494482692, -4.2231537511901
EM Calorimeter has 7 hits. Total Edep is 967.12227158091 (MeV)
Hadron Calorimeter has 0 hits. Total Edep is 0 (MeV)
Run terminated.
Run Summary
Number of events processed : 1
User=0.07s Real=0.09s Sys=0.01s
... write Root file : B5.root - done
WARNING: 1 event has been kept for refreshing and/or reviewing.
"/vis/reviewKeptEvents" to review them.
/control/shell ls

```

Session :

Scene tree, Help, History

Useful tips viewer-0 (OpenGLStoredQt)

Scene tree Help History

viewer-0 (OpenGLStoredQt)

Scene tree

Scene tree : viewer-0 (OpenGLStoredQt)

Touchables

Show all Hide all

Viewer properties

Property	Value
autoRefresh	True
auxiliaryEdge	False
background	0 0 0 1
culling	1
cutawayMode	union
defaultColour	1 1 1 1
defaultTextColour	0 0 1 1
edge	False
explodeFactor	1 1 mm
globalLineWidthScale	1
globalMarkerScale	1
hiddenEdge	False
hiddenMarker	False
lightsMove	object
lightsThetaPhi	54.7356 45 deg
lightsVector	1 1 1
lineSegmentsPerCircle	24
picking	False
projection	orthogonal
rotationStyle	constrainUpDirection
sectionPlane	off

Picking informations Picking mode active

Visualization, one tab per viewer
Interactivity with mouse: rotate, zoom, move, pick

Output

```

Drift Chamber 2 has 5 hits.
Layer[0] : time 34.706100916825 (nsec) --- local (x,y) -224.16660513171, -0.21355242280892
Layer[1] : time 36.37640752814 (nsec) --- local (x,y) -251.45832124829, -1.2334283123023
Layer[2] : time 38.046694157875 (nsec) --- local (x,y) -278.6416463582, -2.2065434918955
Layer[3] : time 39.717018612375 (nsec) --- local (x,y) -306.03356668968, -3.1589879612698
Layer[4] : time 41.387329111728 (nsec) --- local (x,y) -333.34494482692, -4.2231537511901
EM Calorimeter has 7 hits. Total Edep is 967.12227158091 (MeV)
Hadron Calorimeter has 0 hits. Total Edep is 0 (MeV)
Run terminated.
Run Summary
Number of events processed : 1
User=0.07s Real=0.09s Sys=0.01s
... write Root file : B5.root - done
WARNING: 1 event has been kept for refreshing and/or reviewing.
"/vis/reviewKeptEvents" to review them.
/control/shell ls

```

Session :

Scene tree, Help, History

viewer-0 (OpenGLStoredQt)

Scene tree

Scene tree : viewer-0 (OpenGLStoredQt)

Touchables

Show all Hide all

Viewer properties

Property	Value
autoRefresh	True
auxiliaryEdge	False
background	0 0 0 1
culling	1
cutawayMode	union
defaultColour	1 1 1 1
defaultTextColour	0 0 1 1
edge	False
explodeFactor	1 1 mm
globalLineWidthScale	1
globalMarkerScale	1
hiddenEdge	False
hiddenMarker	False
lightsMove	object
lightsThetaPhi	54.7356 45 deg
lightsVector	1 1 1
lineSegmentsPerCircle	24
picking	False
projection	orthogonal
rotationStyle	constrainUpDirection
sectionPlane	off

Picking informations Picking mode active

Useful tips viewer-0 (OpenGLStoredQt)

Toolbar and menubar controlled by icons.mac file, add your own without coding

Output

```

Drift Chamber 2 has 5 hits.
Layer[0] : time 34.706100916825 (nsec) --- local (x,y) -224.16660513171, -0.21355242280892
Layer[1] : time 36.37640752814 (nsec) --- local (x,y) -251.45832124829, -1.2334283123023
Layer[2] : time 38.046694157875 (nsec) --- local (x,y) -278.6416463582, -2.2065434918955
Layer[3] : time 39.717018612375 (nsec) --- local (x,y) -306.03356668968, -3.1589879612698
Layer[4] : time 41.387329111728 (nsec) --- local (x,y) -333.34494482692, -4.2231537511901
EM Calorimeter has 7 hits. Total Edep is 967.12227158091 (MeV)
Hadron Calorimeter has 0 hits. Total Edep is 0 (MeV)
Run terminated.
Run Summary
Number of events processed : 1
User=0.07s Real=0.09s Sys=0.01s
... write Root file : B5.root - done
WARNING: 1 event has been kept for refreshing and/or reviewing.
"/vis/reviewKeptEvents" to review them.
/control/shell ls

```

Session :

Scene tree, Help, History

Scene tree Help History

```
/run/beamOn 1  
/control/shell ls
```

Useful tips

viewer-0 (OpenGLStoredQt)

Help tree browser, free text search

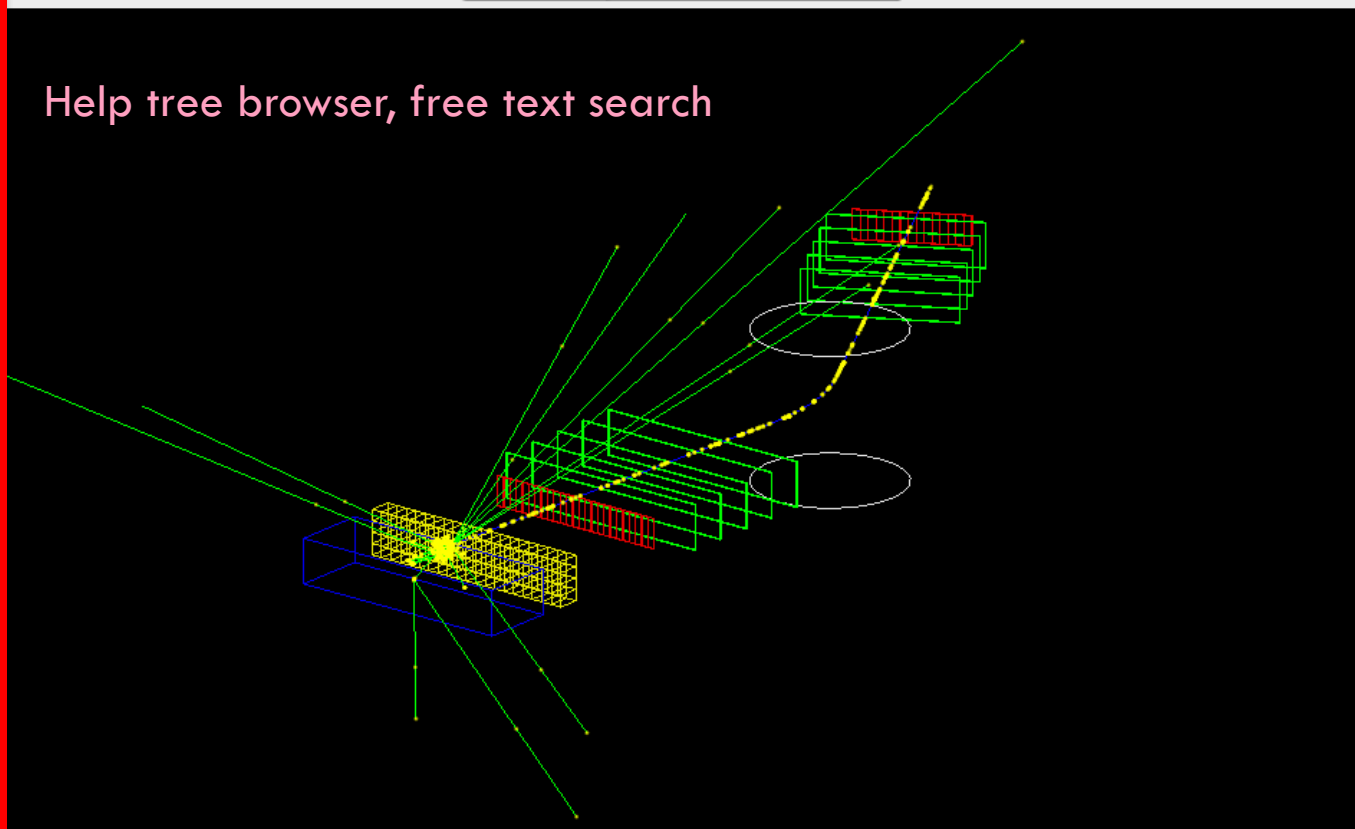

Output

```
Drift Chamber 2 has 5 hits.  
Layer[0] : time 34.706100916825 (nsec) --- local (x,y) -224.16660513171, -0.21355242280892  
Layer[1] : time 36.37640752814 (nsec) --- local (x,y) -251.45832124829, -1.2334283123023  
Layer[2] : time 38.046694157875 (nsec) --- local (x,y) -278.6416463582, -2.2065434918955  
Layer[3] : time 39.717018612375 (nsec) --- local (x,y) -306.03356668968, -3.1589879612698  
Layer[4] : time 41.387329111728 (nsec) --- local (x,y) -333.34494482692, -4.2231537511901  
EM Calorimeter has 7 hits. Total Edep is 967.12227158091 (MeV)  
Hadron Calorimeter has 0 hits. Total Edep is 0 (MeV)  
Run terminated.  
Run Summary  
Number of events processed : 1  
User=0.07s Real=0.09s Sys=0.01s  
... write Root file : B5.root - done  
WARNING: 1 event has been kept for refreshing and/or reviewing.  
"/vis/reviewKeptEvents" to review them.  
/control/shell ls
```

Session :

Scene tree, Help, History

Scene tree

Help

History

```

/run/beamOn 1
/control/shell ls

```

Useful tips

viewer-0 (OpenGLStoredQt)

History, re-select command

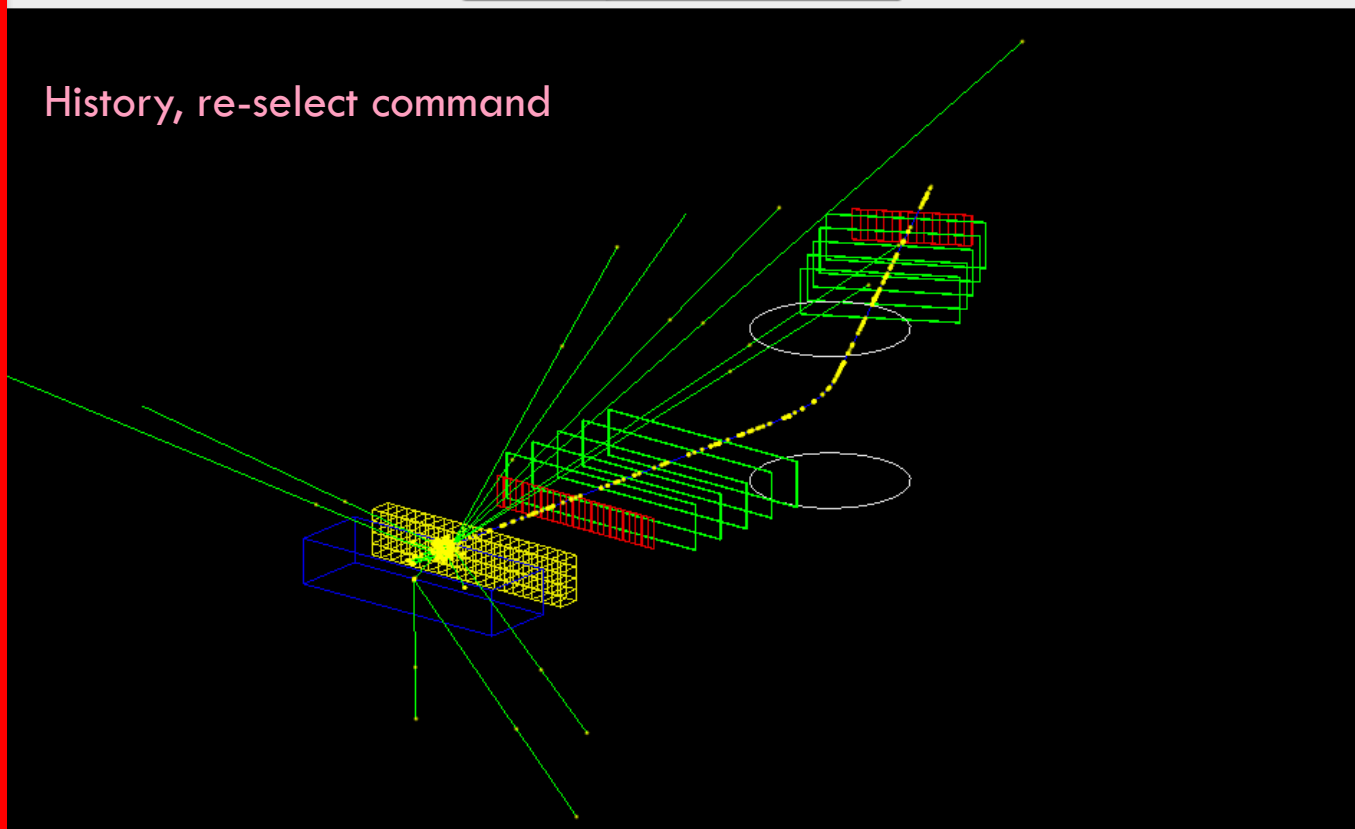

Output

```

Drift Chamber 2 has 5 hits.
Layer[0] : time 34.706100916825 (nsec) --- local (x,y) -224.16660513171, -0.21355242280892
Layer[1] : time 36.37640752814 (nsec) --- local (x,y) -251.45832124829, -1.2334283123023
Layer[2] : time 38.046694157875 (nsec) --- local (x,y) -278.6416463582, -2.2065434918955
Layer[3] : time 39.717018612375 (nsec) --- local (x,y) -306.03356668968, -3.1589879612698
Layer[4] : time 41.387329111728 (nsec) --- local (x,y) -333.34494482692, -4.2231537511901
EM Calorimeter has 7 hits. Total Edep is 967.12227158091 (MeV)
Hadron Calorimeter has 0 hits. Total Edep is 0 (MeV)
Run terminated.
Run Summary
Number of events processed : 1
User=0.07s Real=0.09s Sys=0.01s
... write Root file : B5.root - done
WARNING: 1 event has been kept for refreshing and/or reviewing.
"/vis/reviewKeptEvents" to review them.
/control/shell ls

```

Session :

Scene tree, Help, History

viewer-0 (OpenGLStoredQt)

Scene tree

Scene tree : viewer-0 (OpenGLStoredQt)

- Touchables
 - worldPhysical [0]
 - magneticPhysical [0]
 - firstArmPhysical [0]
 - hodoscope1Physica...
 - hodoscope1Physica...
 - hodoscope1Physica...
 - hodoscope1Physica...
 - hodoscope1Physica...
 - hodoscope1Physica...
 - hodoscope1Physica...

Show all Hide all

Viewer properties

Property	Value
autoRefresh	True
auxiliaryEdge	False
background	0 0 0 1
culling	1
cutawayMode	union
defaultColour	1 1 1 1
defaultTextColour	0 0 1 1
edge	False
explodeFactor	1 1 mm
globalLineWidthScale	1
globalMarkerScale	1
hiddenEdge	False
hiddenMarker	False
lightsMove	object
lightsThetaPhi	54.7356 45 deg
lightsVector	1 1 1
lineSegmentsPerCircle	24
picking	False
projection	orthogonal
rotationStyle	constrainUpDirection
sectionPlane	off

Picking informations Picking mode active

Scene tree: edit visualization (e.g. hide volumes)

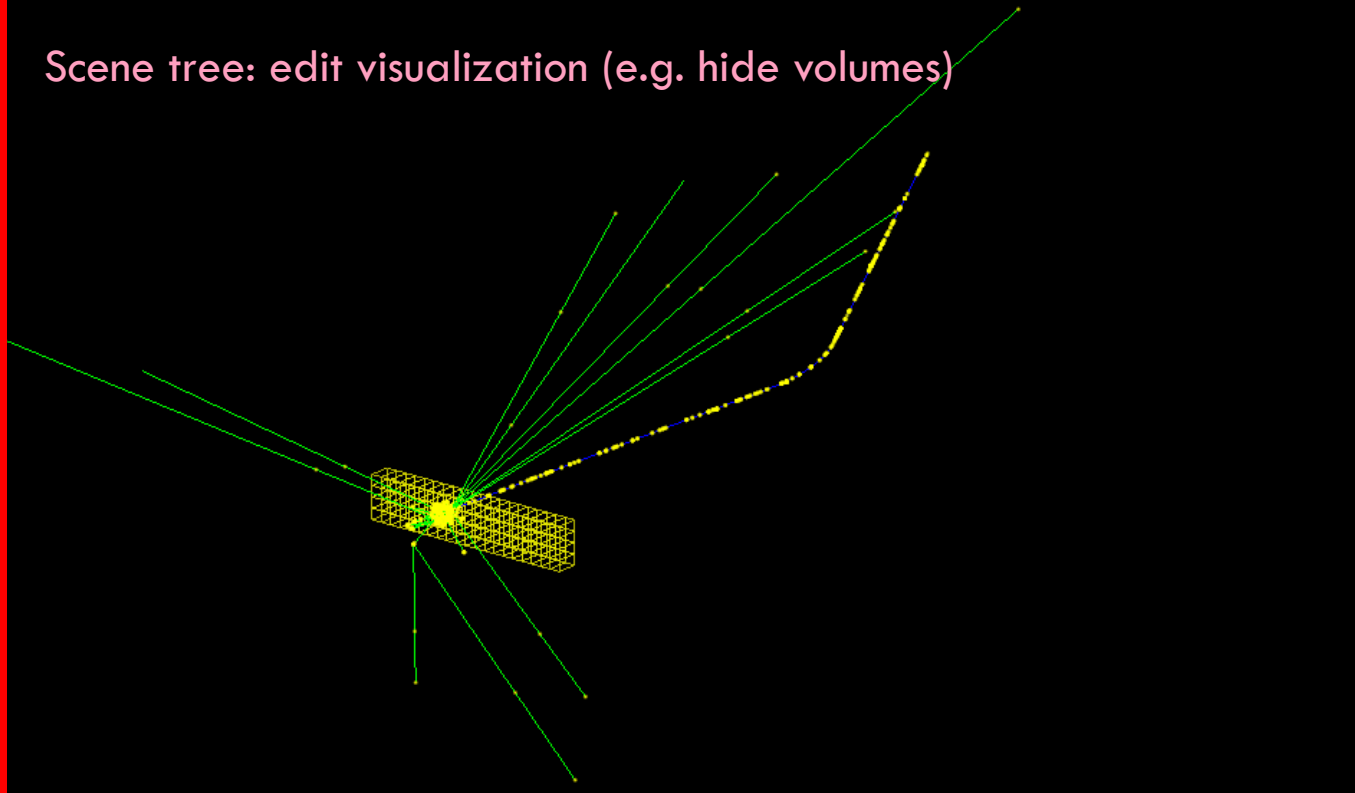

Output

```

Drift Chamber 2 has 5 hits.
Layer[0] : time 34.706100916825 (nsec) --- local (x,y) -224.16660513171, -0.21355242280892
Layer[1] : time 36.37640752814 (nsec) --- local (x,y) -251.45832124829, -1.2334283123023
Layer[2] : time 38.046694157875 (nsec) --- local (x,y) -278.6416463582, -2.2065434918955
Layer[3] : time 39.717018612375 (nsec) --- local (x,y) -306.03356668968, -3.1589879612698
Layer[4] : time 41.387329111728 (nsec) --- local (x,y) -333.34494482692, -4.2231537511901
EM Calorimeter has 7 hits. Total Edep is 967.12227158091 (MeV)
Hadron Calorimeter has 0 hits. Total Edep is 0 (MeV)
Run terminated.
Run Summary
Number of events processed : 1
User=0.07s Real=0.09s Sys=0.01s
... write Root file : B5.root - done
WARNING: 1 event has been kept for refreshing and/or reviewing.
"/vis/reviewKeptEvents" to review them.
/control/shell ls
  
```

Session :

Visualization I.

MOVIES

- One can make movies that show time development of an event:
 - e.g. a shower in slow motion
- **see a collection** of example movies (prepared by John Allison)
- “how to make a move” **presentation** (by Joseph Perl)

10 GeV proton

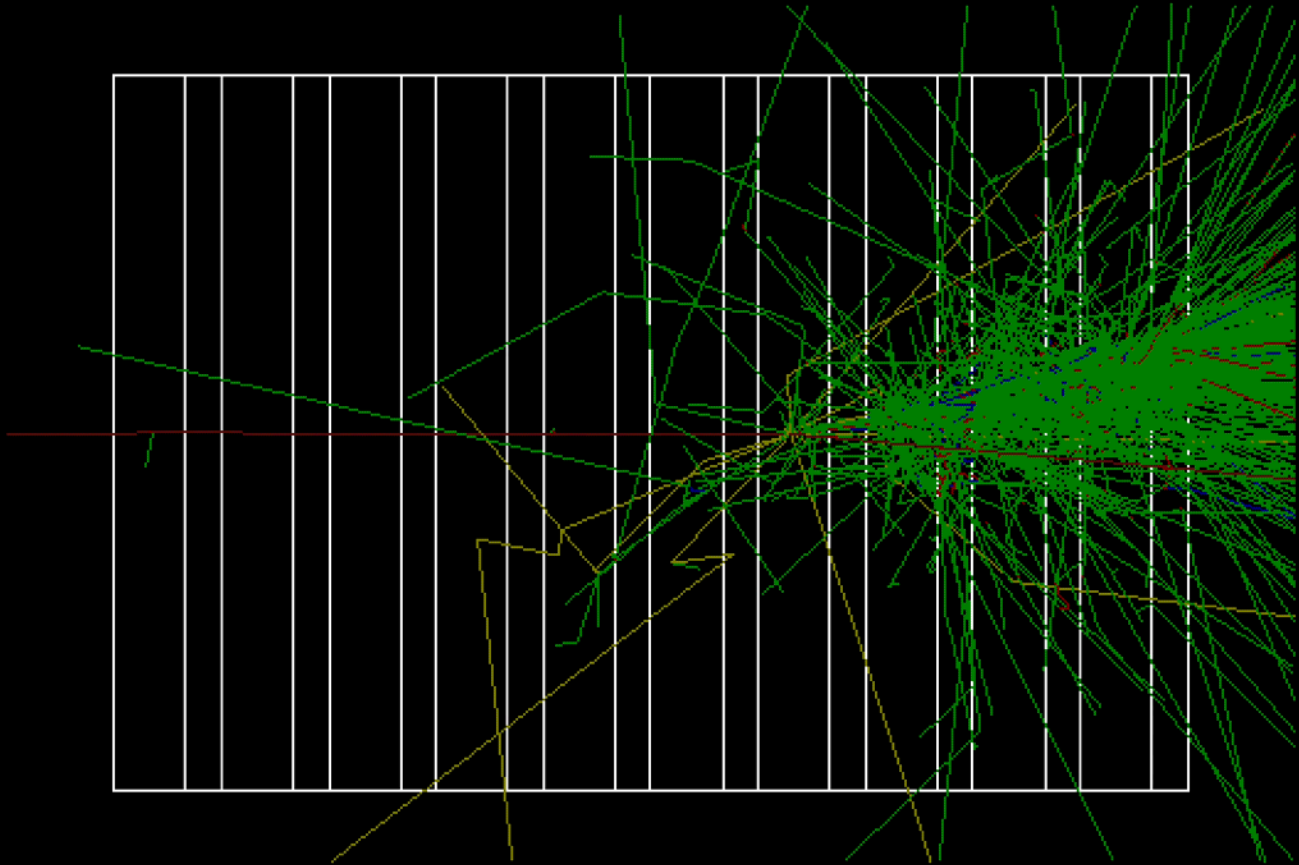

Visualization I.

QUESTIONS