

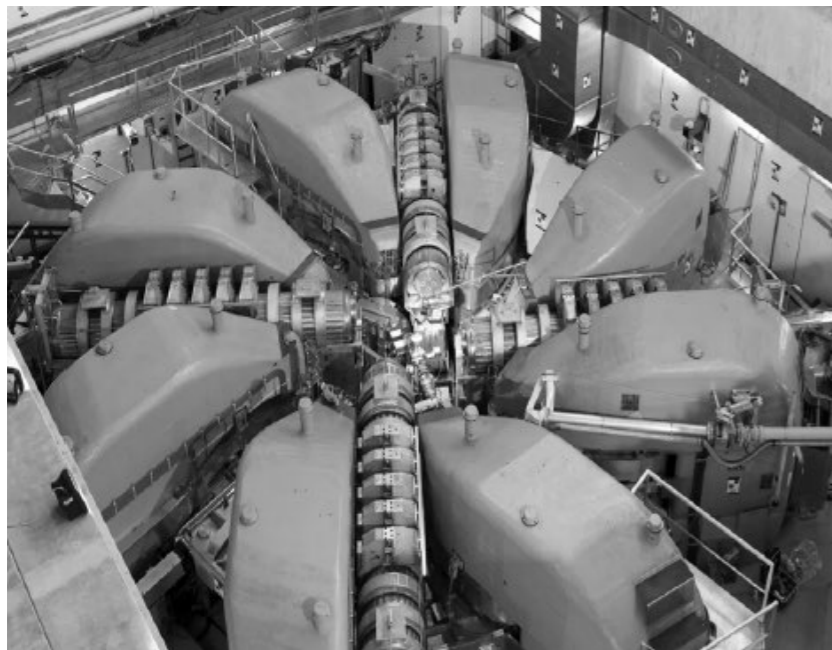

Towards an High intensity Muon Beam (HiMB) at PSI

Angela Papa, University of Pisa/INFN and Paul Scherrer Institut
Boston, USA

APS 2019, July 29th - August 2nd



HiMB motivations

- Aim: $O(10^{10})$ muon/s; Surface (positive) muon beam ($p = 28 \text{ MeV}/c$); **DC** beam
- Time schedule: **O(2025)**
- PSI delivers the highest intensity DC μ^+ beam:
 $5 \times 10^8 \mu^+/s$
- Next generation cLFV experiments require higher muon rates
- New opportunities for future muon (particle physics) based experiments
- New opportunities for μ SR experiments
- Different experiments demand for a variety of beam characteristics:
 - DC vs pulsed
 - Momentum depends on applications: stopped beams require low momenta
- Here focus on **DC low momenta muon beams**
- Maintain PSI leadership in DC low momentum high intensity muon beams

 **Fermilab** $\rightarrow 5 \times 10^{10} \mu^-/s$
 **Mu2e: $R_{\mu e} = \mathcal{O}(10^{-17})$**

 **J-PARC** $\rightarrow 10^{10} \mu^-/s$
COMET: $R_{\mu e} = \mathcal{O}(10^{-17})$

The role of the low energy precision physics

- The Standard Model of particle physics: A great triumph of the modern physics but not the ultimate theory

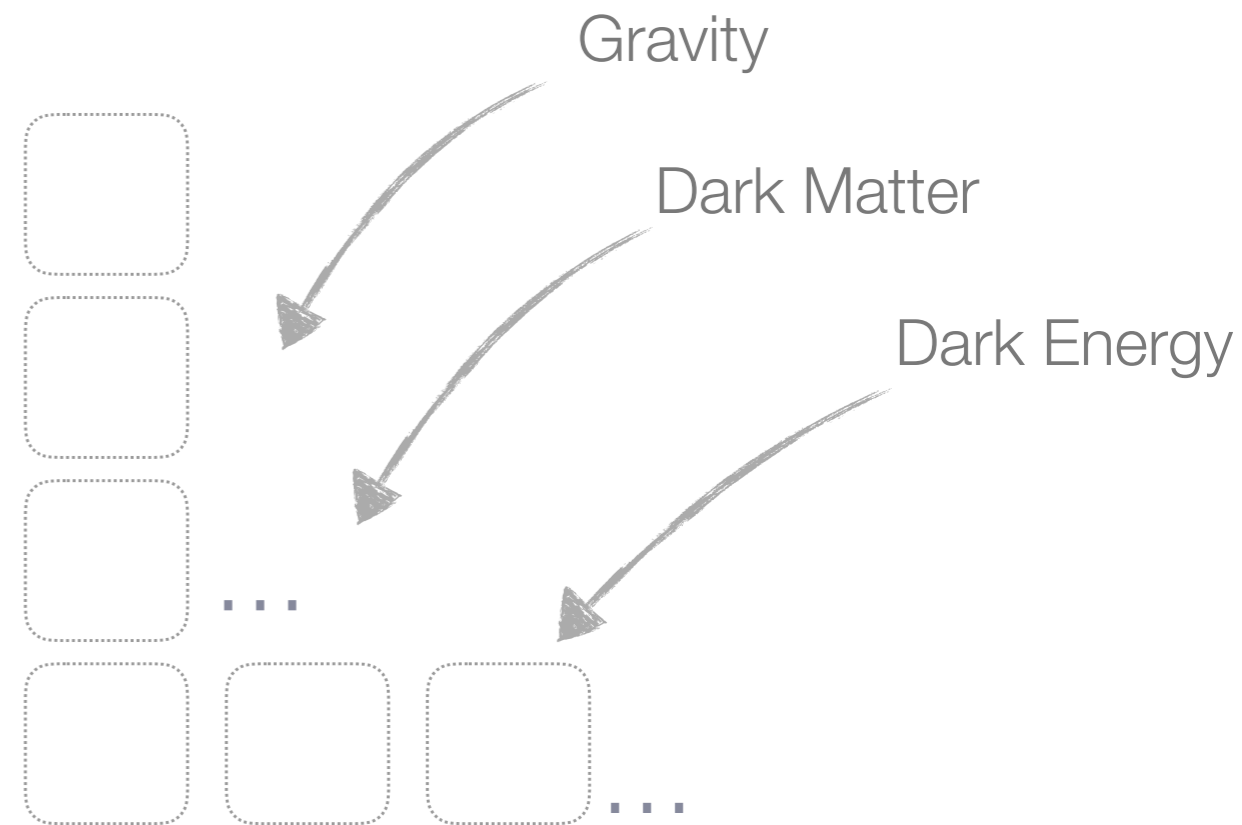
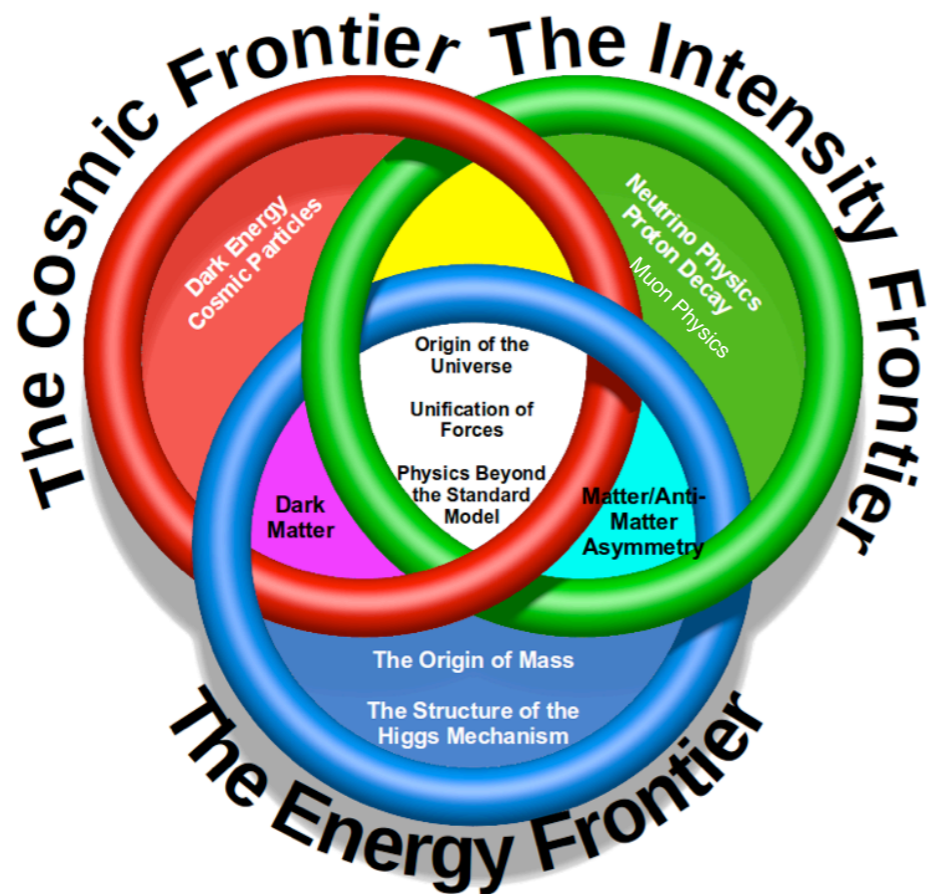

- Low energy precision physics: Rare/forbidden decay searches, symmetry tests, precision measurements very sensitive tool for unveiling new physics and probing very high energy scale

cLFV evidence: A clear signature of New Physics

SM with massive neutrinos (Dirac)

$$BR(\mu \rightarrow eee) \approx 10^{-54}$$

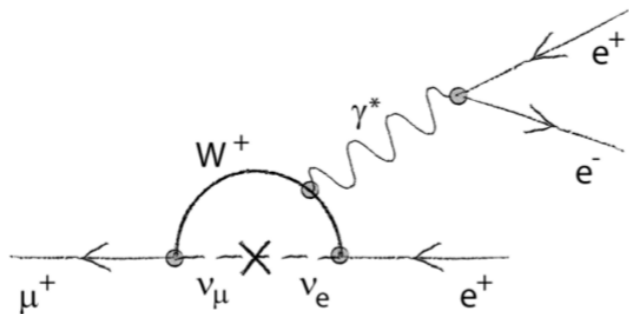

ν oscillations

too small to access experimentally

i.e. SU(5) SUSY-GUT or SO(10) SUSY-GUT

$$BR(\mu \rightarrow eee) \gg 10^{-54}$$

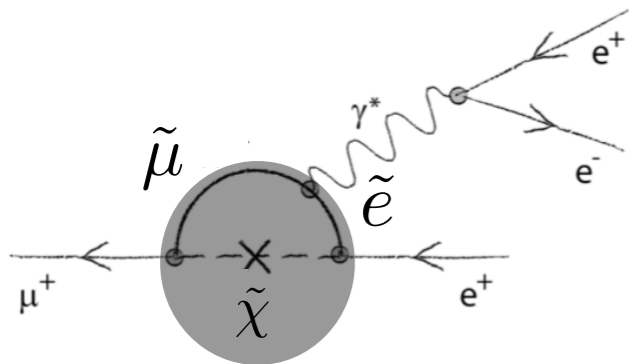

i.e. EXTRA Z'

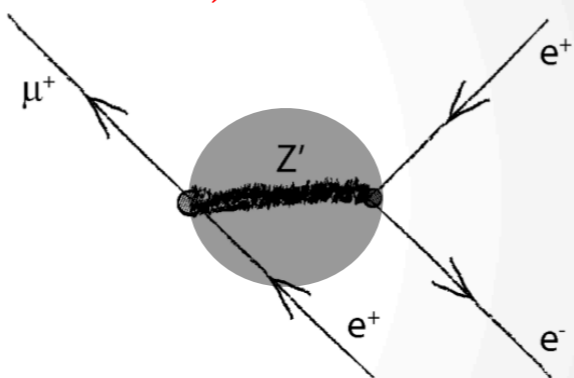

**an experimental evidence:
a clear signature of New Physics NP**
(SM background FREE)

to unveil behind SM physics
via virtual particles

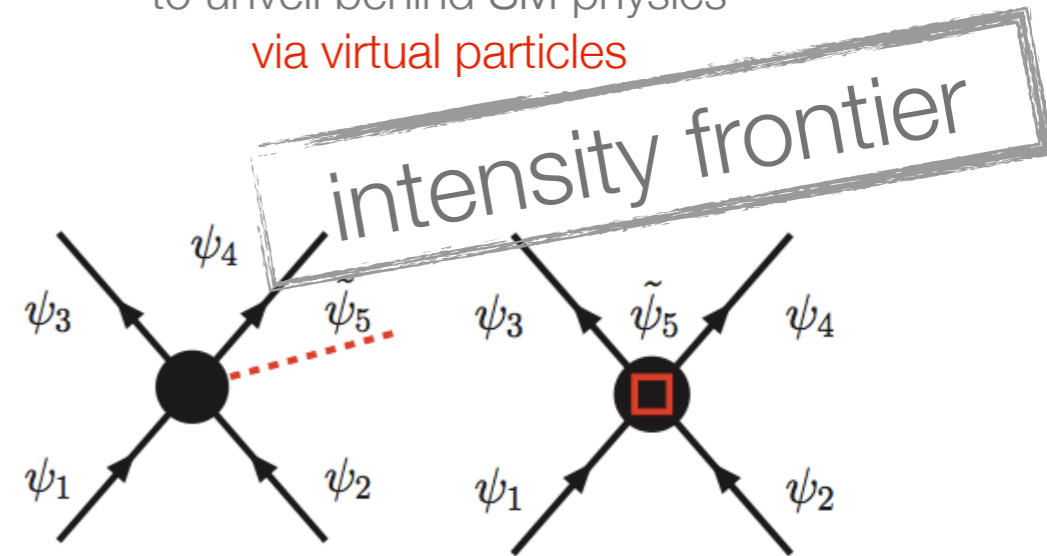

to probe otherwise unreachable and
unexploited new physics energy scale

high energy probe

$$\mathcal{L}_{eff} = \mathcal{L}_{SM} + \sum_{d>4} \frac{c_n^{(d)}}{\Lambda^{d-4}} \mathcal{O}^{(d)}$$

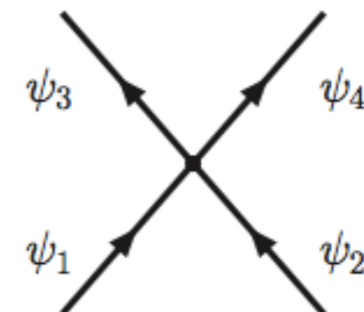

$$\frac{1}{\Lambda^2}$$

Beam features vs experiment requirements

- Dedicated beam lines for high precision and high sensitive SM test/BSM probe at the world's highest beam intensities

$I_{\text{beam}} \sim 10^8 - 10^{10} \mu/s$

DC or Pulsed?

$I_{\text{beam}} \sim 10^{11} \mu/s$

- DC beam for coincidence experiments

- $\mu \rightarrow e \gamma$, $\mu \rightarrow e e e$

- Pulse beam for non-coincidence experiments

- μ -e conversion

@ PSI

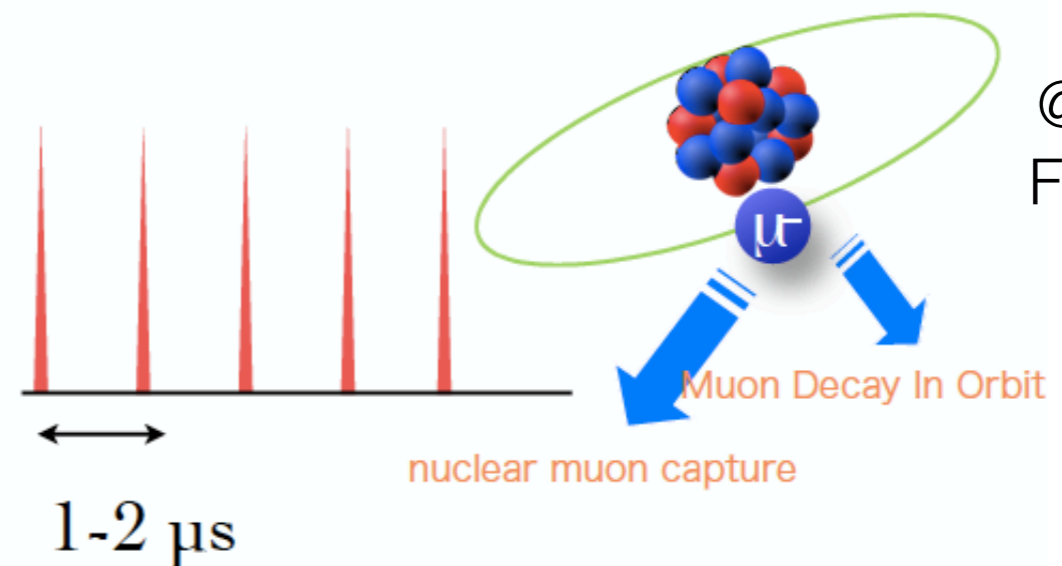
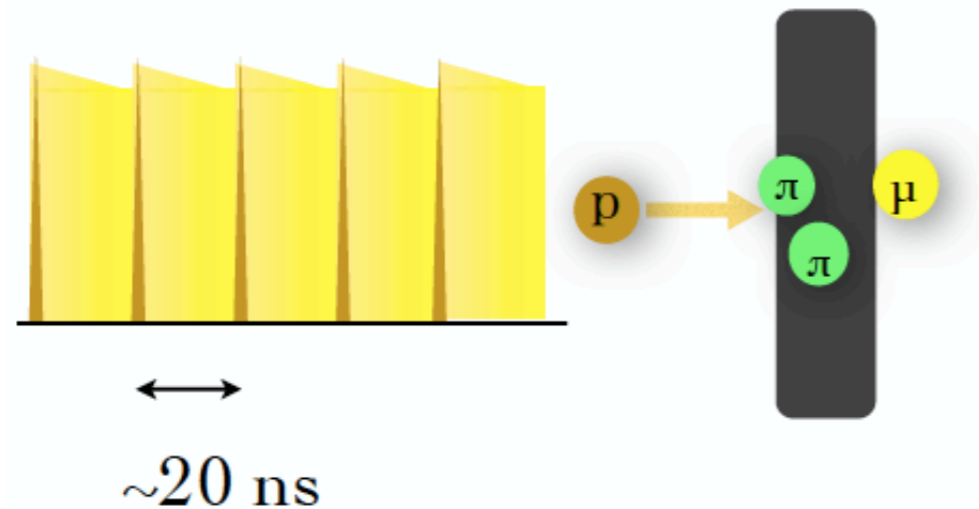

@ JPARC,
FERMILAB

The world's most intense continuous muon beam

- PSI delivers the most intense continuous low momentum muon beam in the world (**Intensity Frontiers**)
 - Intensity = 5×10^8 muon/s, low momentum $p = 28$ MeV/c

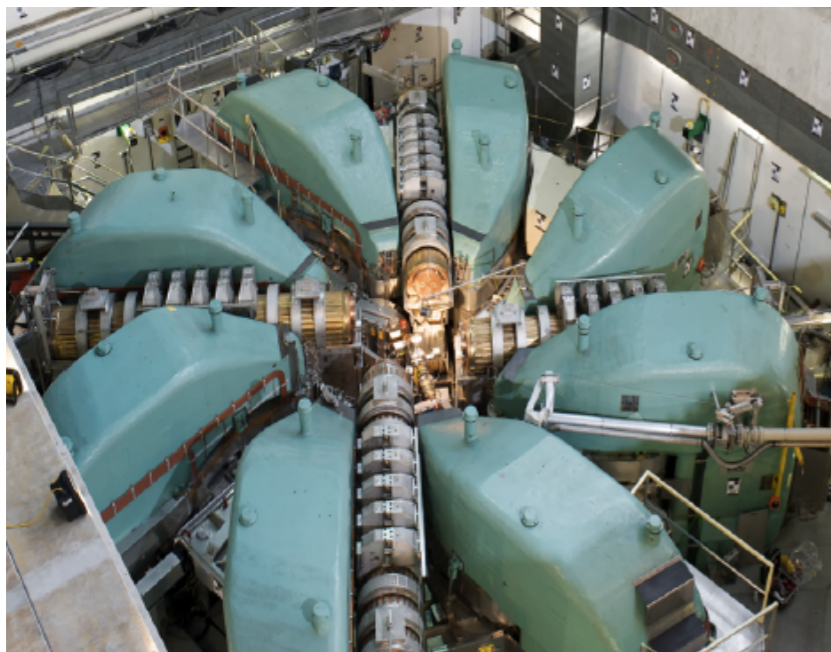

590 MeV proton ring cyclotron
Time structure: 50 MHz/20 ns
Power: 1.4 MW

PSI landscape



The world's most intense continuous muon beam

- PSI High Intensity Proton Accelerator experimental areas
- Two production targets
- SINQ neutron source

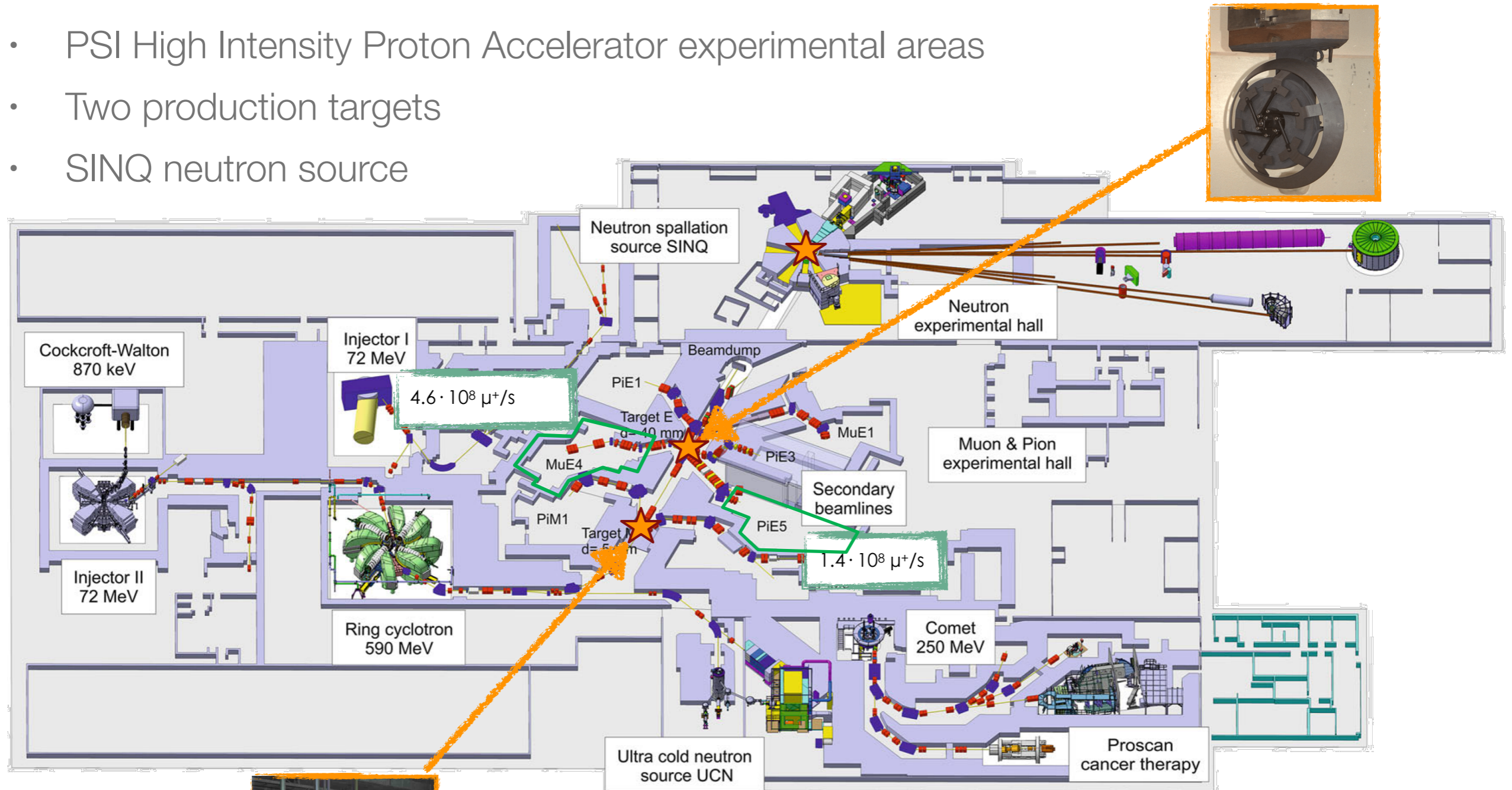

Muon production via pion decay

- Single pion production at 290 MeV proton energy (LAB)
- Low-energy muon beam lines typically tuned to surface- μ^+ at ~ 28 MeV/c
- Note: surface- $\mu^- \rightarrow$ polarized positively charged muons (spin antiparallel to the momentum)
- Contribution from cloud muons at similar momentum about 100x smaller
- Negative muons only available as cloud muons

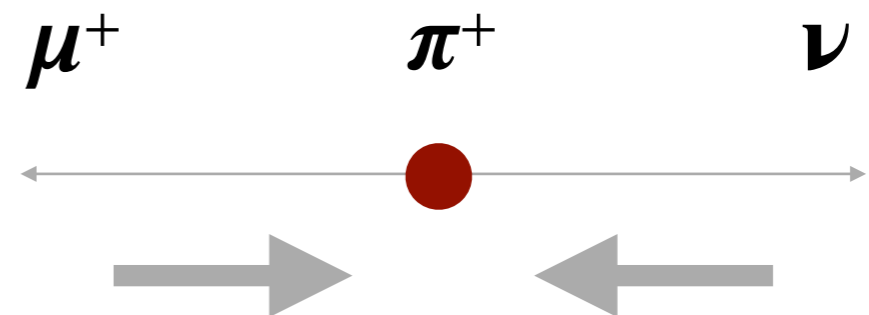
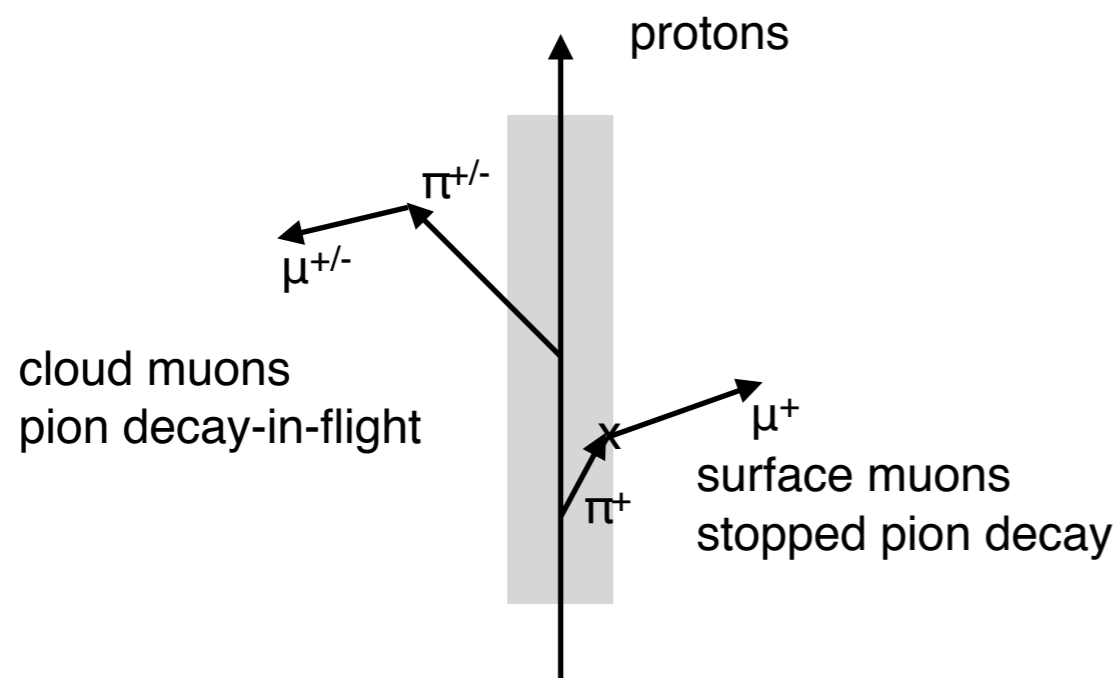
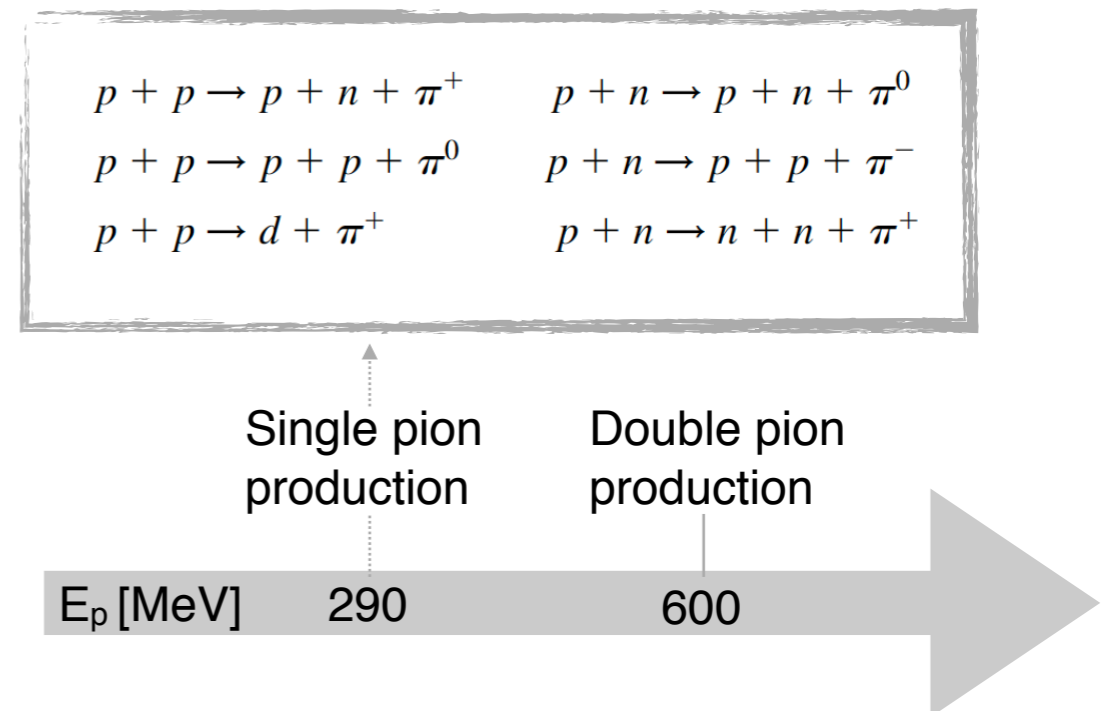

HiMB Simulation

- Geant4 pion production cross sections not optimised for low energies
- Implemented our own pion production cross section into Geant4/G4beamline based on measured data and two available parametrizations (**HiMB model**)
- Valid for all pion energies, proton energies < 1000 MeV, all angles and all materials
- Reliable results at 10% level

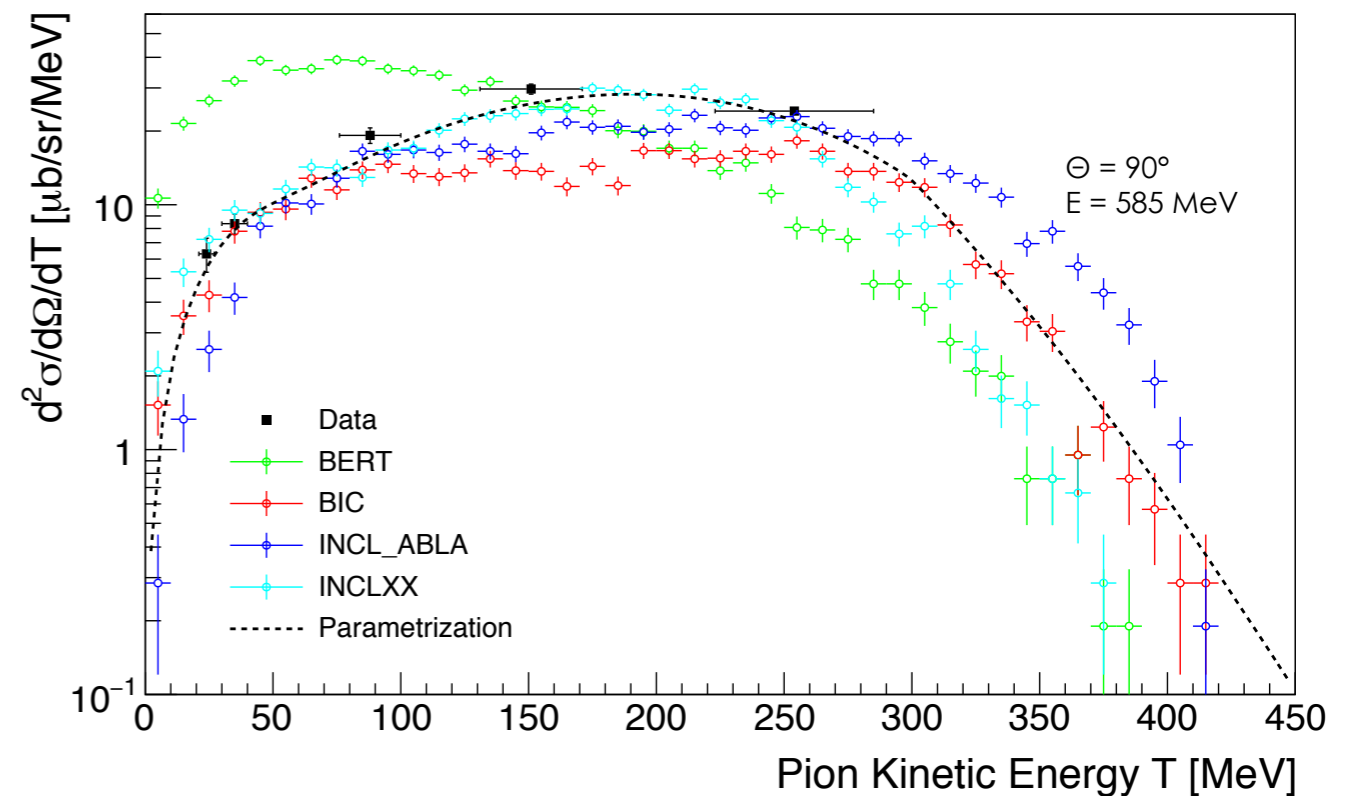
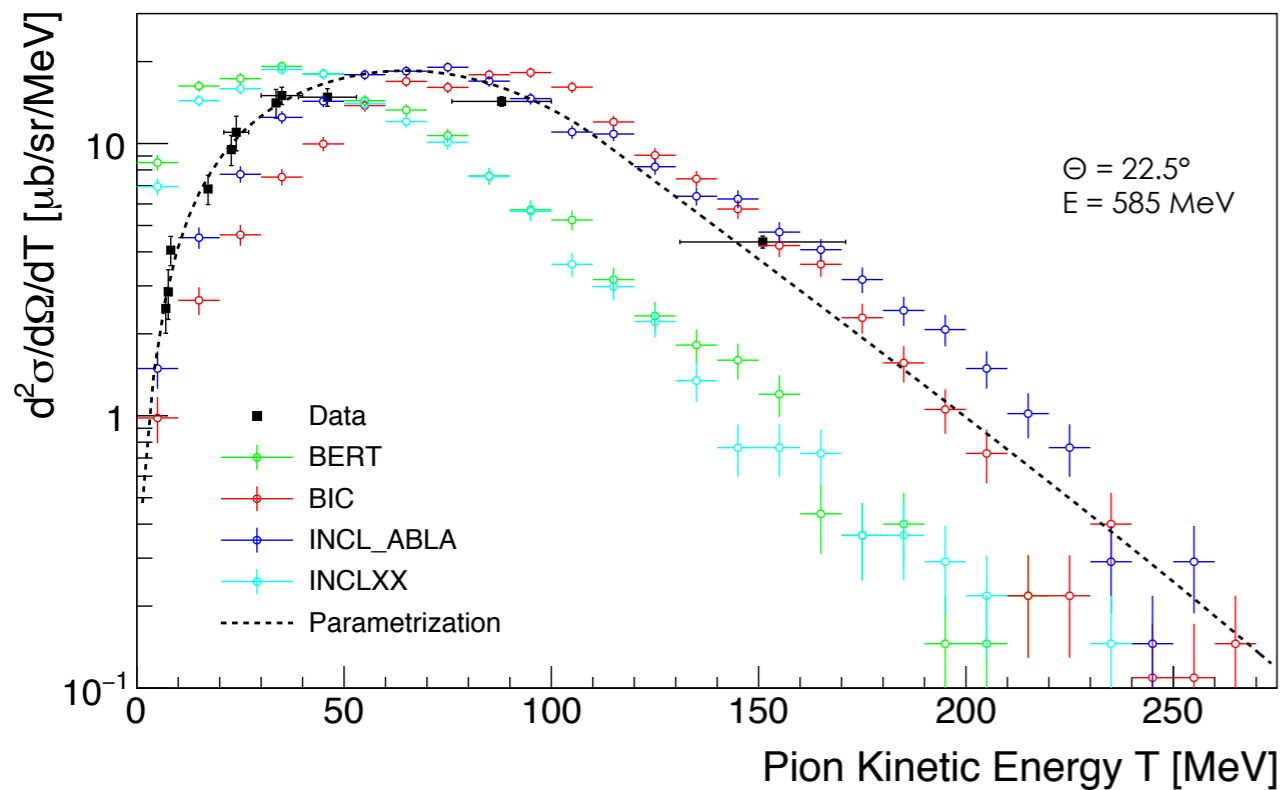

R. L. Burman and E. S. Smith, Los Alamos Tech. Report LA-11502-MS (1989)

R. Frosch, J. Löffler, and C. Wigger, PSI Tech. Report TM-11-92-01 (1992)

F. Berg et al., Phys. Rev. Accel. Beams **19**, 024701 (2016)

HiMB model validation

- Full simulation of μ E4 and π E5 beam lines starting from proton beam
- Detailed field maps available for all elements
- Very good agreement between simulation and measurements

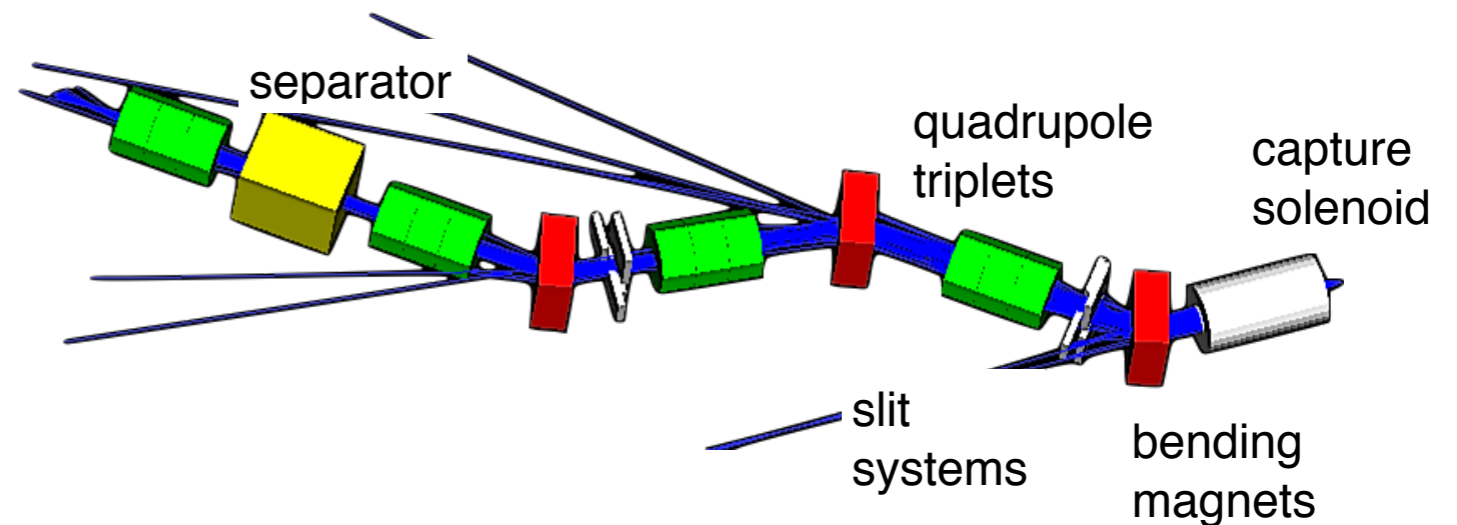
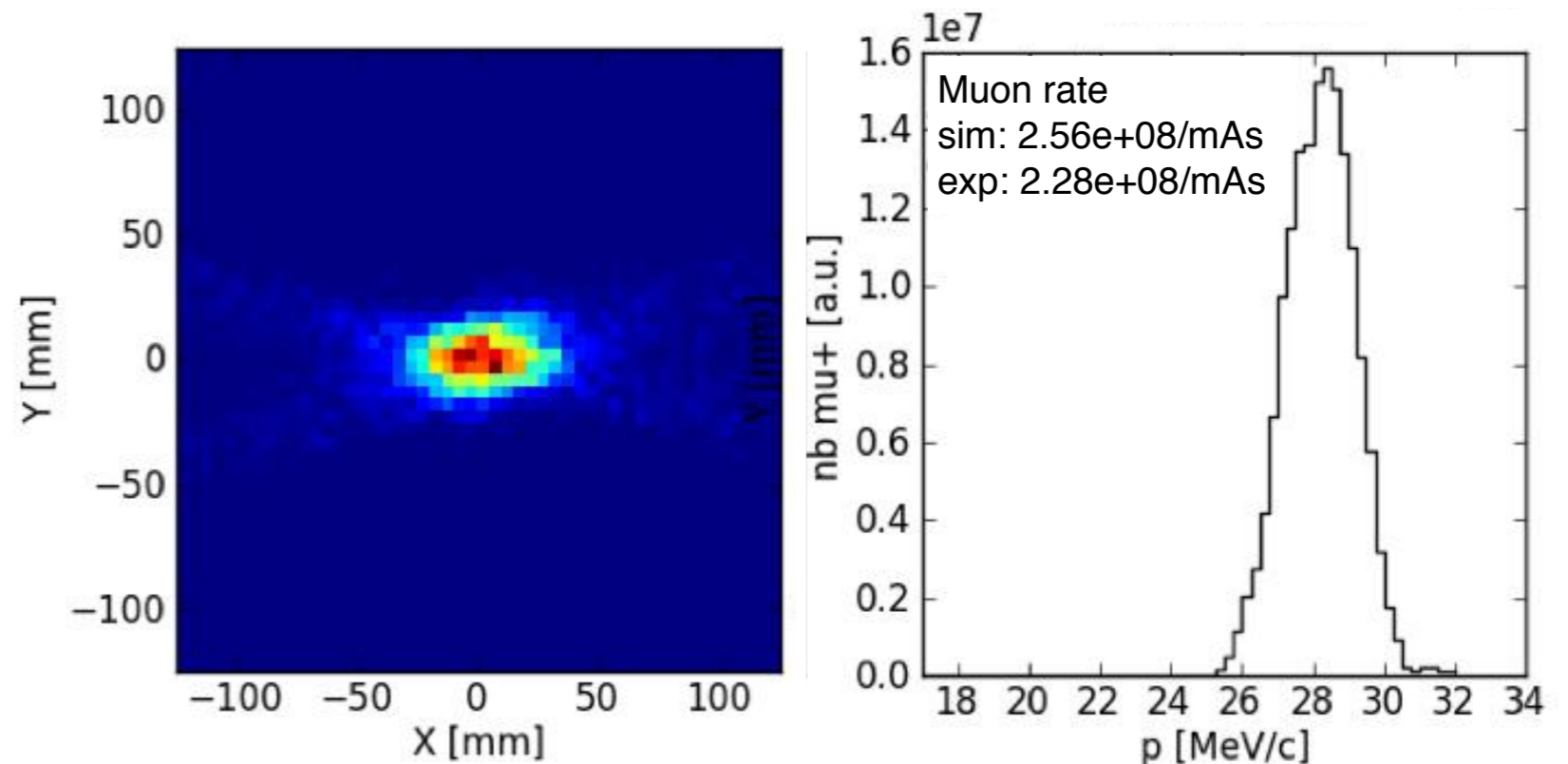

Initial HiMB concept: @SINQ

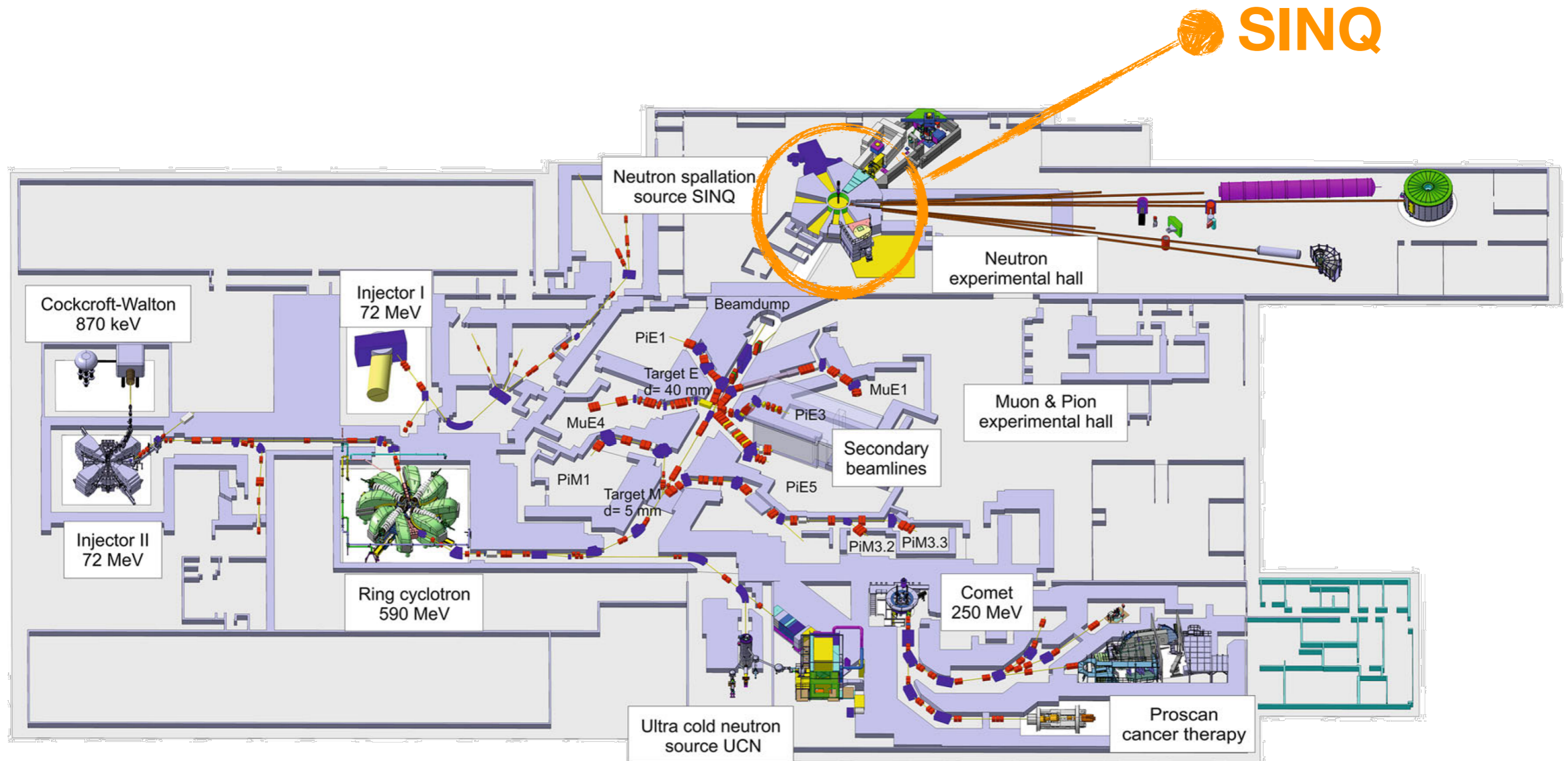

Initial HiMB concept: @SINQ

- Source simulation (below safety window):
 9×10^{10} surface- μ^+ /s @ 1.7 mA I_p
- Profit from stopping of full beam
- Residual proton beam (~ 1 MW) dumped on SINQ
- Replace existing quadrupoles with solenoids:
 - Preserve proton beam footprint
 - Capture backward travelling surface muons
- Extract muons in Dipole fringe field
- Backward travelling pions stopped in beam window
- Capturing turned out to be difficult :
 - Large phase space (divergence & 'source' extent)
 - Capture solenoid aperture needed to be increased, but constrained by moderator tank
- High radiation level close to target

SINQ spallation target

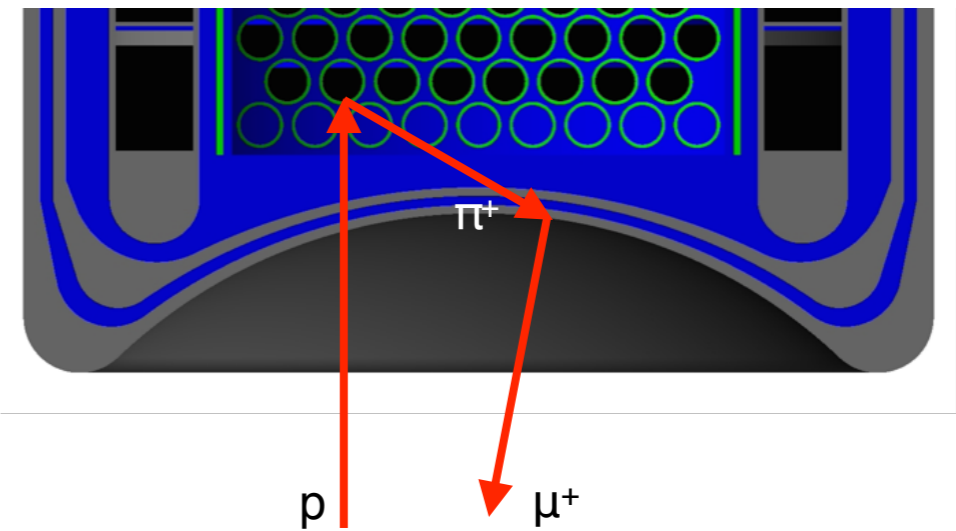

HiMB Conceptual Layout

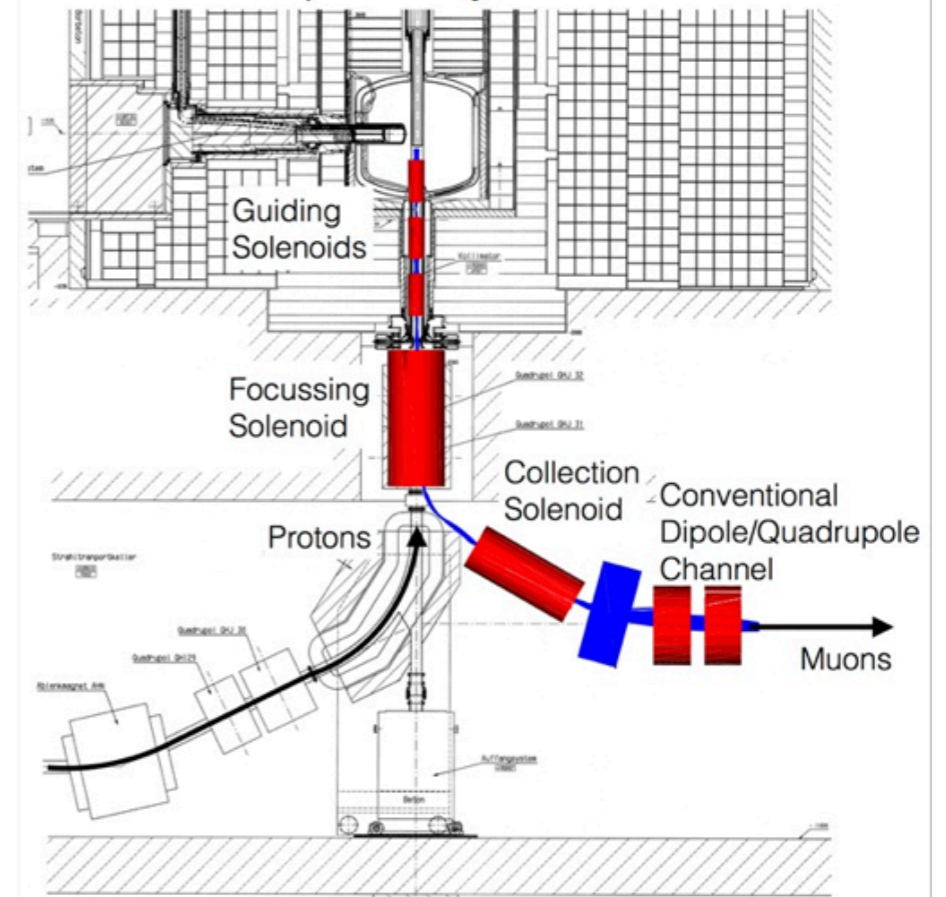

Initial HiMB concept: @SINQ

- Source simulation (below safety window):
 9×10^{10} surface- μ^+ /s @ 1.7 mA I_p
- Profit from stopping of full beam
- Residual proton beam (~ 1 MW) dumped on SINQ
- Replace existing quadrupoles with solenoids:
 - Preserve proton beam footprint
 - Capture backward travelling surface muons
- Extract muons in Dipole fringe field
- Backward travelling pions stopped in beam window
- Capturing turned out to be difficult :
 - Large phase space (divergence & 'source' extent)
 - Capture solenoid aperture needed to be increased, but constrained by moderator tank
- High radiation level close to target
- Due these constraints and after several iterations with different capturing elements:
 - **Not enough captures muons to make an high intensity beam**
 - **Alternative solution: HiMB @ EH**

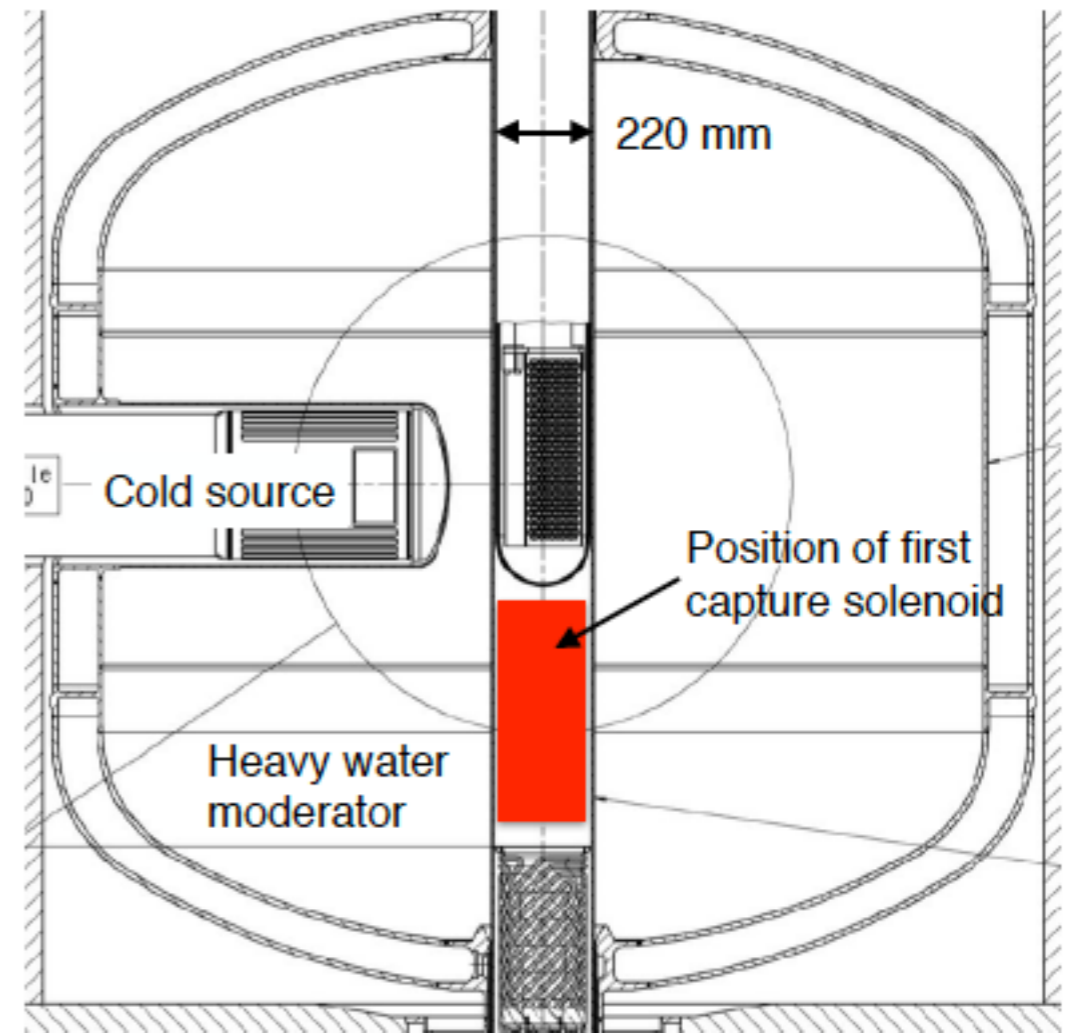

Current High Muon Beam Intensity: @Main Experimental Hall

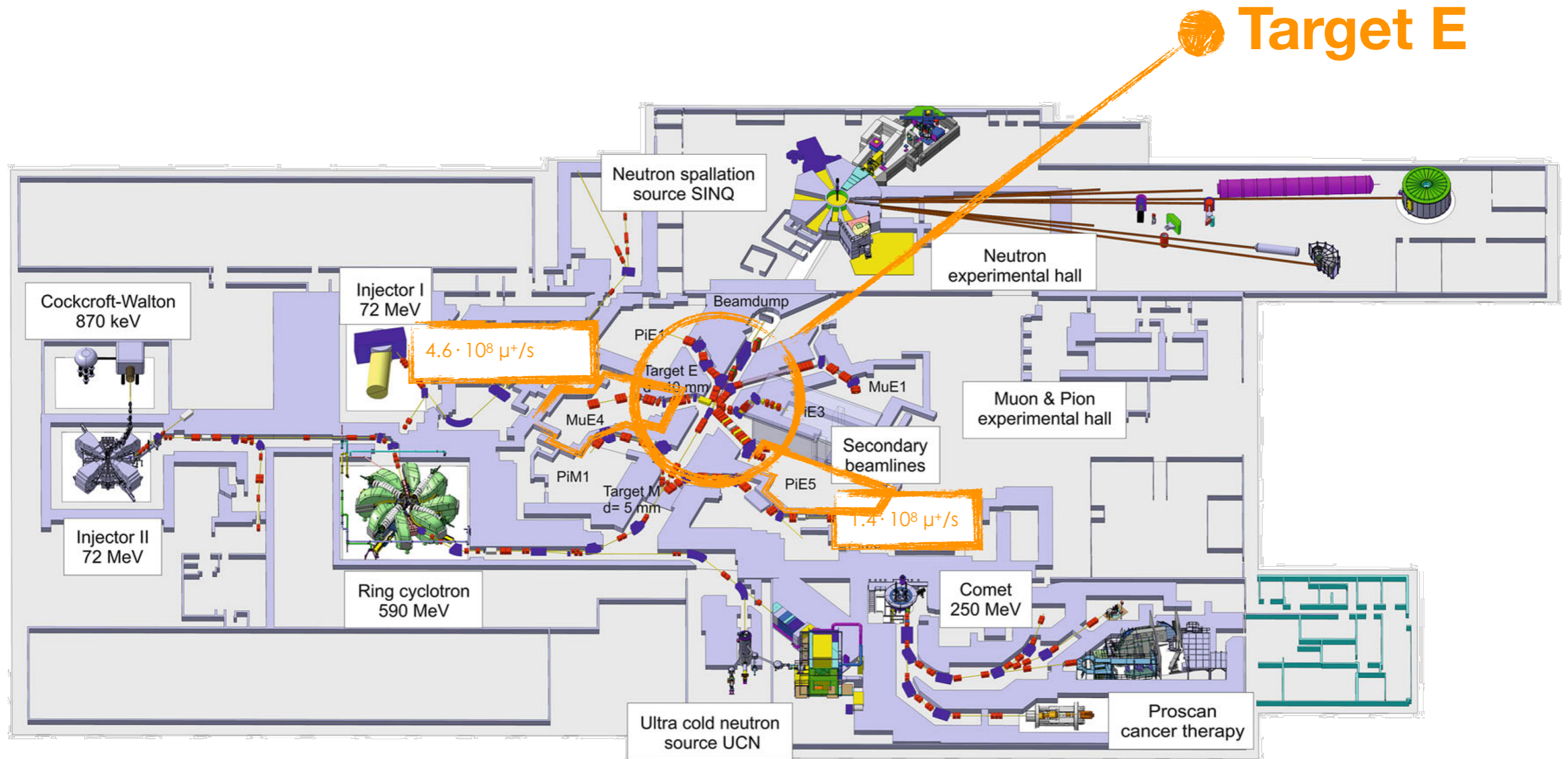

Target E

- Rotating target (1 Hz)
- Polycrystalline graphite
- 40 mm length in beam direction
- 50 kW proton beam energy deposit
- 1700 K radiation cooled
- 30 % loss of protons
- Delivers world most intense surface muon beams

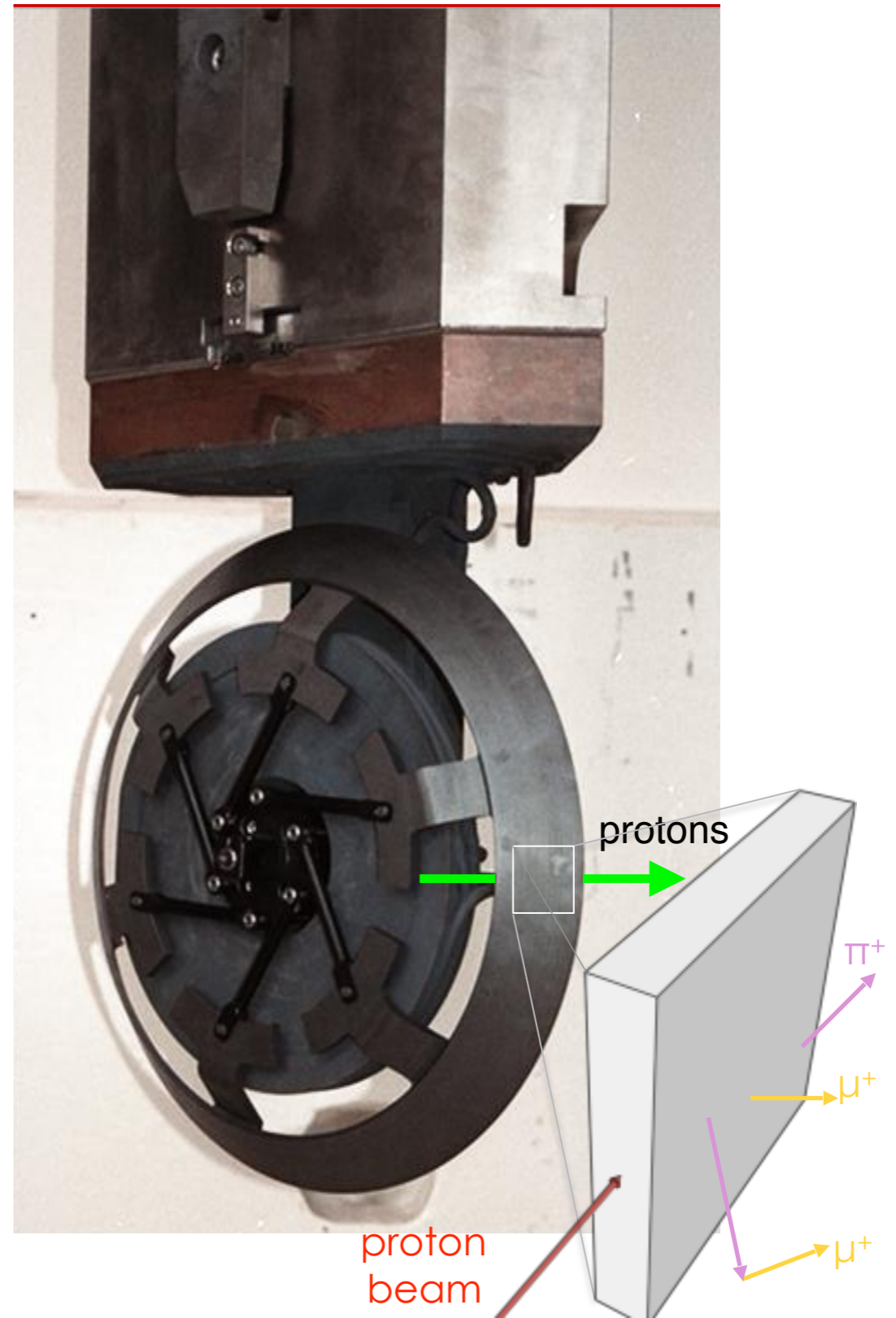

HiMB @ HE

- Back to standard target to exploit possible improvements towards high intensity beams:
 - Target geometry
 - Target alternate materials
 - Beam line high capture efficiency
 - Beam line large phase space acceptance transport channel

Optimization of standard production targets

- Back to standard target to exploit possible improvements towards high intensity beams:
- **Target alternate materials**
 - Search for high pion yield materials -> higher muon yield

relative μ^+ yield $\propto \pi^+$ stop density $\cdot \mu^+$ Range \cdot length

$$\begin{aligned} &\propto n \cdot \sigma_{\pi^+} \cdot SP_{\pi^+} \cdot \frac{1}{SP_{\mu^+}} \cdot \frac{\rho_c (6/12)_c}{\rho_x (Z/A)_x} \\ &\propto Z^{1/3} \cdot Z \cdot \frac{1}{Z} \cdot \frac{1}{Z} \\ &\propto \frac{1}{Z^{2/3}} \end{aligned}$$

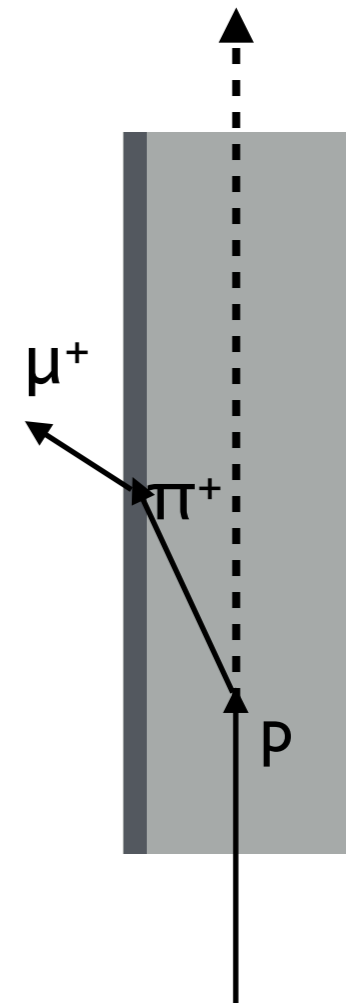

Optimization of standard production targets

- Back to standard target to exploit possible improvements towards high intensity beams:
 - **Target alternate materials**
 - Search for high pion yield materials -> higher muon yield

- Several materials have pion yields > 2x Carbon
- Relative muon yield favours low-Z materials, but difficult to construct as a target
- B₄C and Be₂C show 10-15% gain

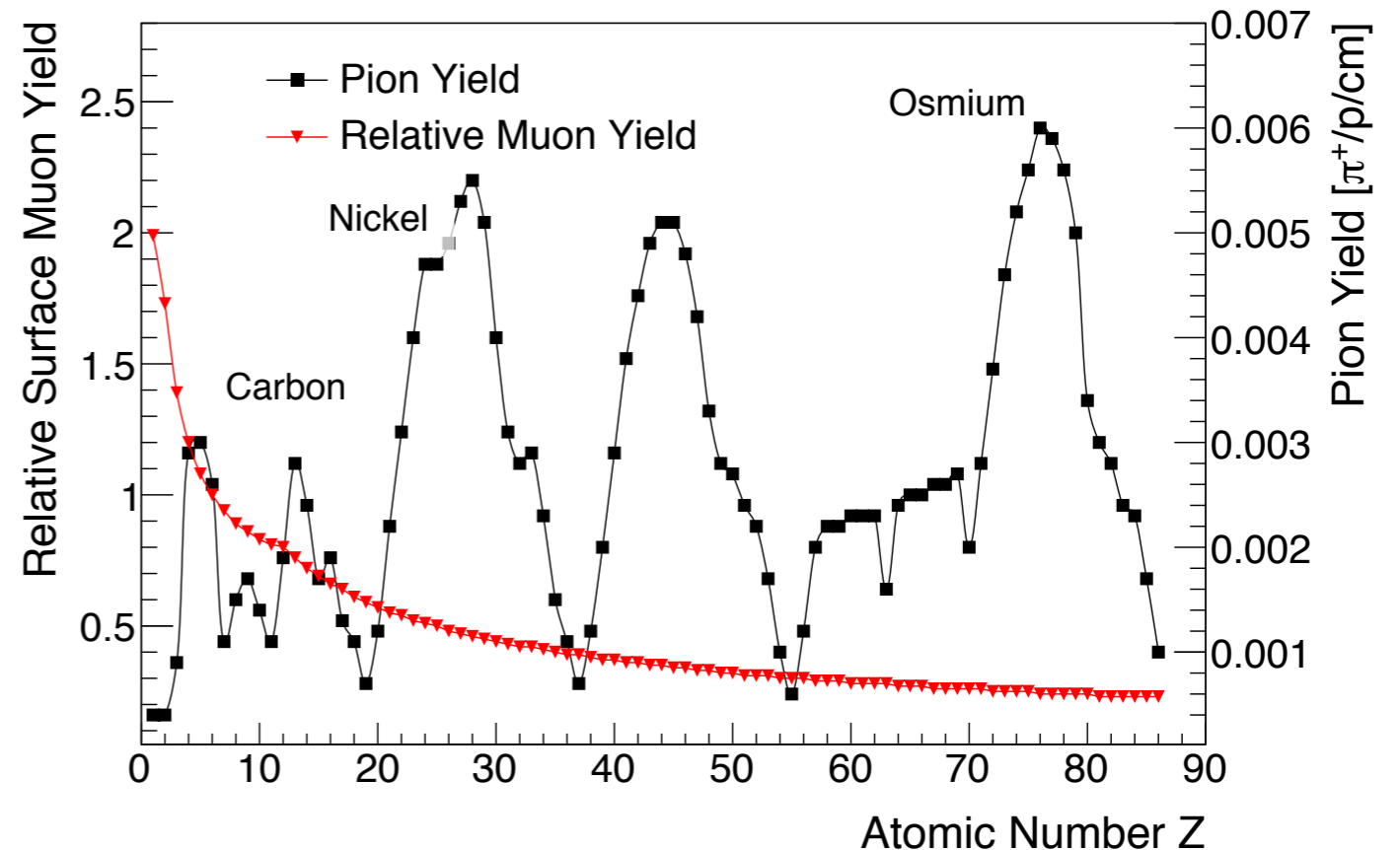

Optimization of standard production targets

- Strategy: either increasing the surface volume (surface area times acceptance depth) or the pion stop density near the surface
- **Target geometry**
 - Comparison studies of different target geometries: **TgE for different lengths**

Surface muon rate

Length [mm]	Upstream	Downstream	Side
10	1.4×10^{10}	9.0×10^9	1.8×10^{10}
20	1.6×10^{10}	1.2×10^{10}	5.1×10^{10}
30	1.9×10^{10}	1.1×10^{10}	8.5×10^{10}
40	1.8×10^{10}	1.1×10^{10}	1.2×10^{11}
60	1.8×10^{10}	1.2×10^{10}	2.1×10^{11}

Optimization of standard production targets

- Strategy: either increasing the surface volume (surface area times acceptance depth) or the pion stop density near the surface
- **Target geometry**
 - Comparison studies of different target geometries: **Different shapes and rotation angles**
 - Enhancements normalised to standard target

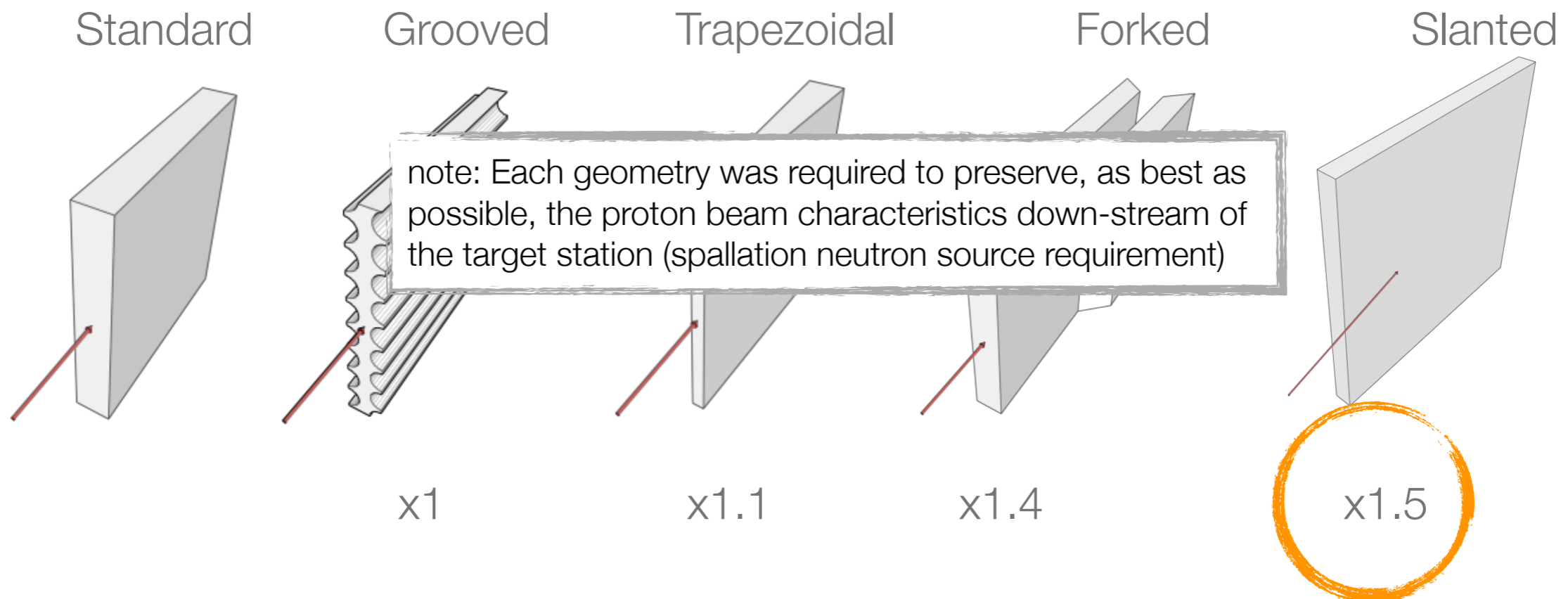

Optimization of standard production targets

- Strategy: either increasing the surface volume (surface area times acceptance depth) or the pion stop density near the surface
- **Target geometry**
 - Comparison studies of different target geometries: **Different shapes and rotation angles**
 - Enhancements normalised to standard target

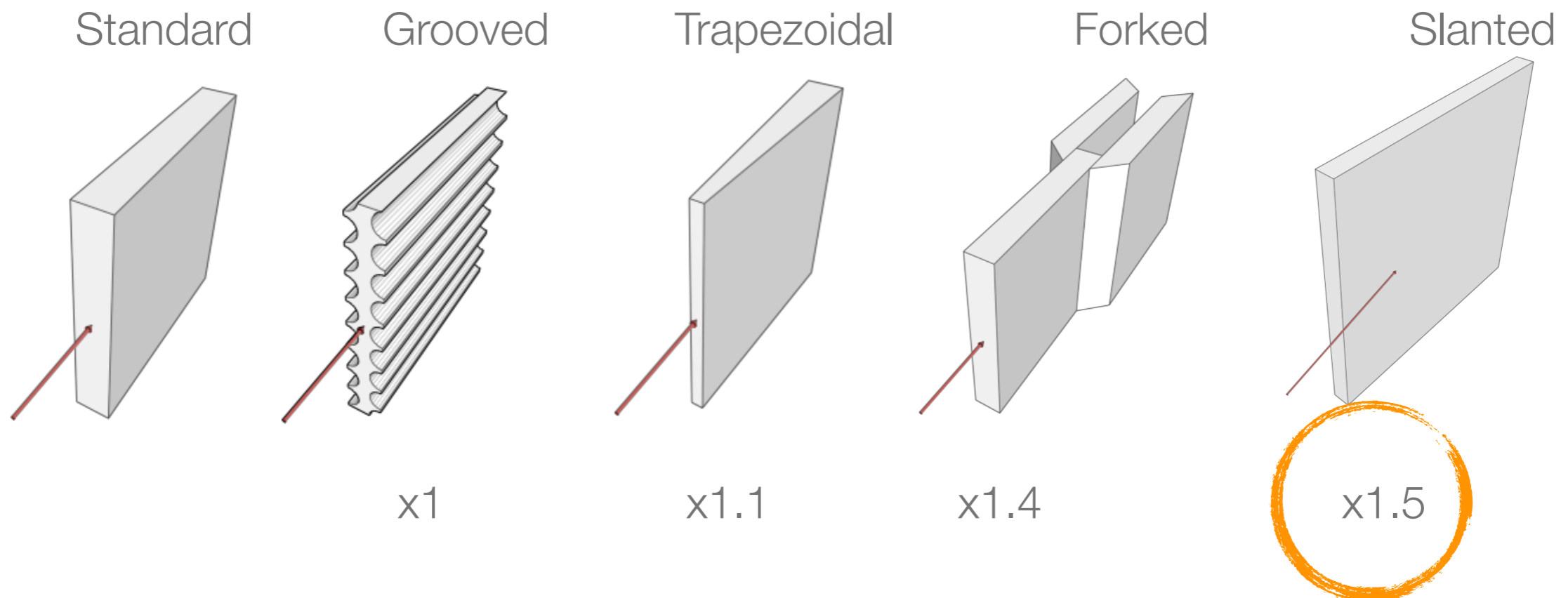

Optimization of standard production targets

- Strategy: either increasing the surface volume (surface area times acceptance depth) or the pion stop density near the surface
- **Target geometry**
 - Comparison studies of different target geometries: **Different rotation angles**
 - Enhancements normalised to standard target

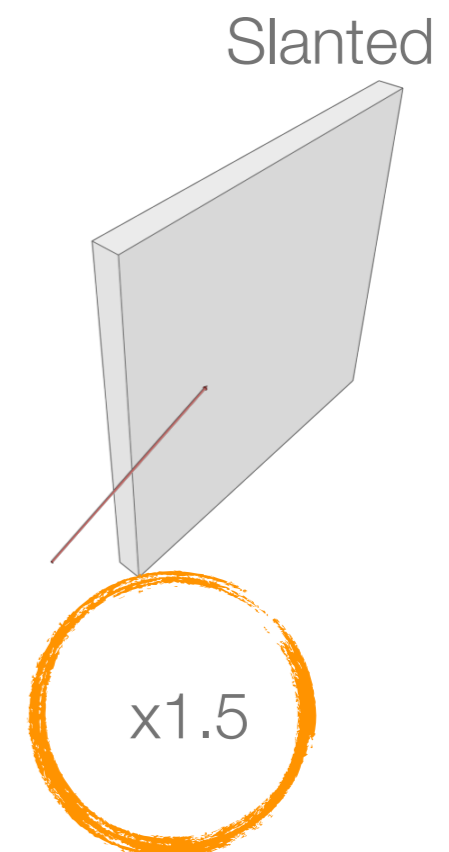
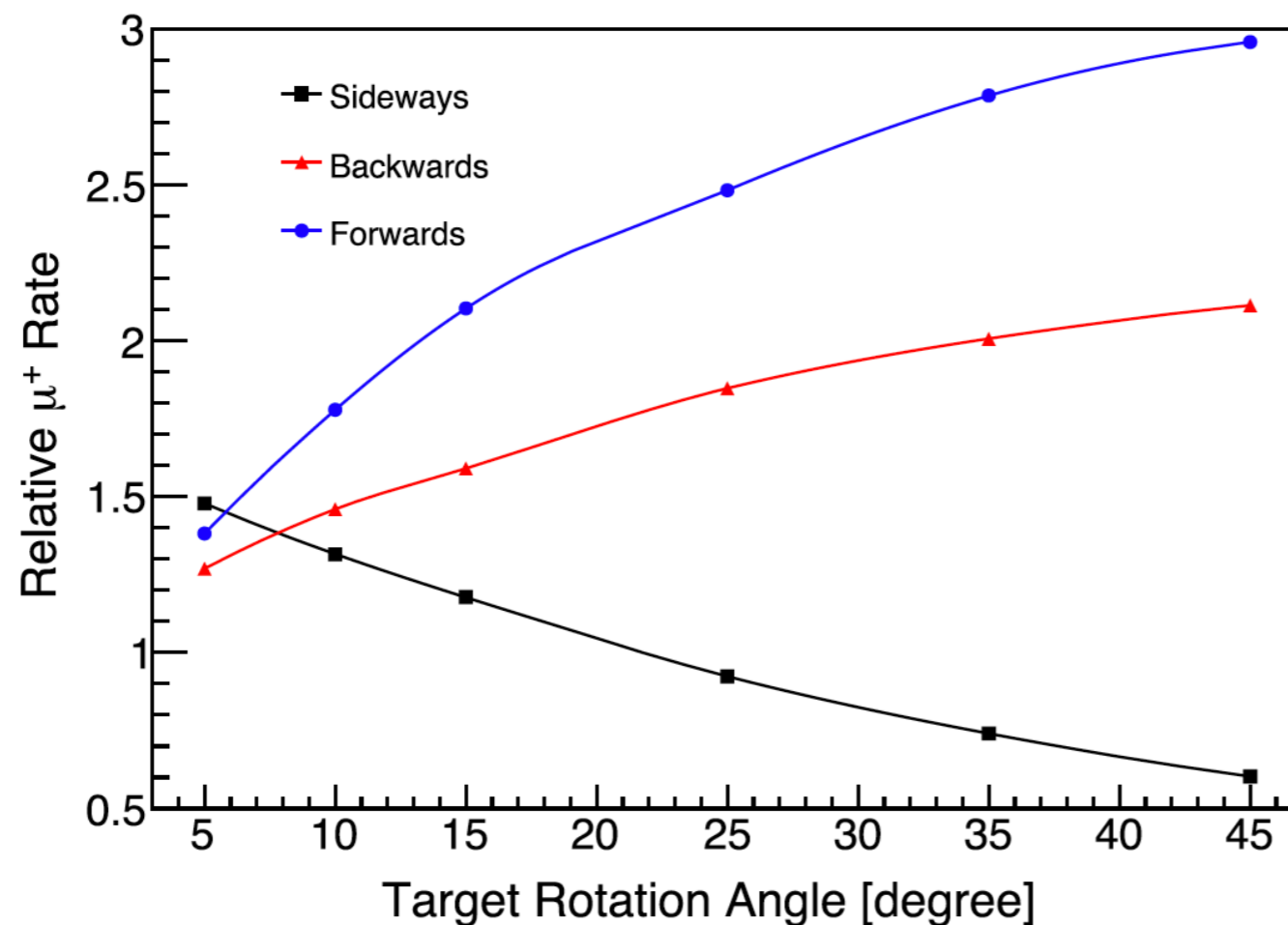

Slanted target: Prototype test

- Upgrade existing graphite production target E 40 mm
 - 8° slanting angle: Measurement in forward / backward / sideways direction
 - Production and implementation feasible
 - Mechanical and thermal simulations completed and no show-stopper found
 - To be installed in week 48 (Nov. 25th) for the remainder of the accelerator period

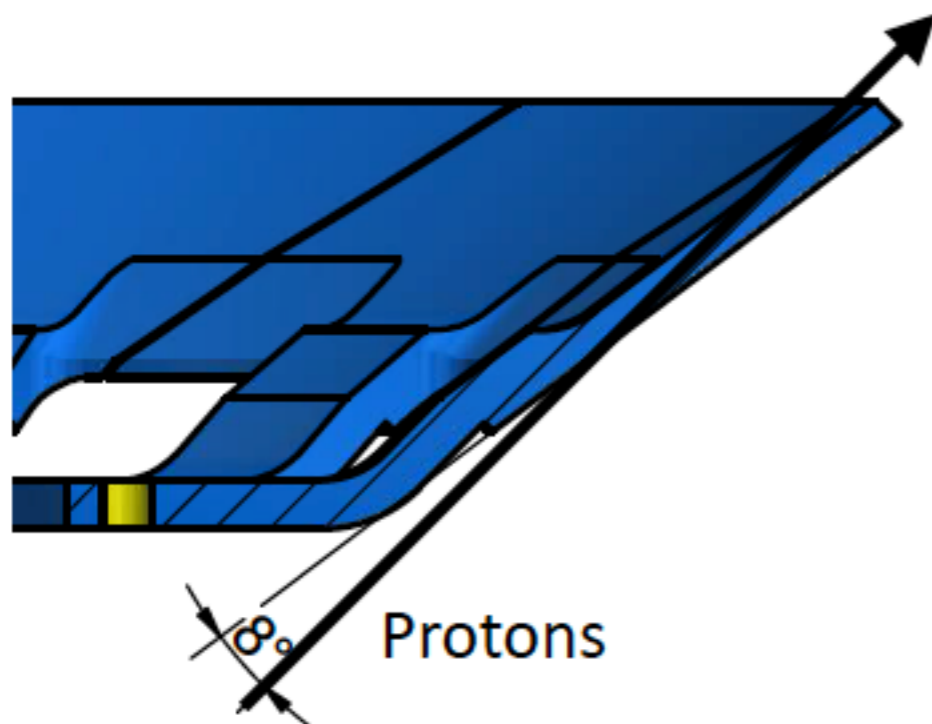

Slanted target: Prototype test

- Expect 30-60 % enhancement

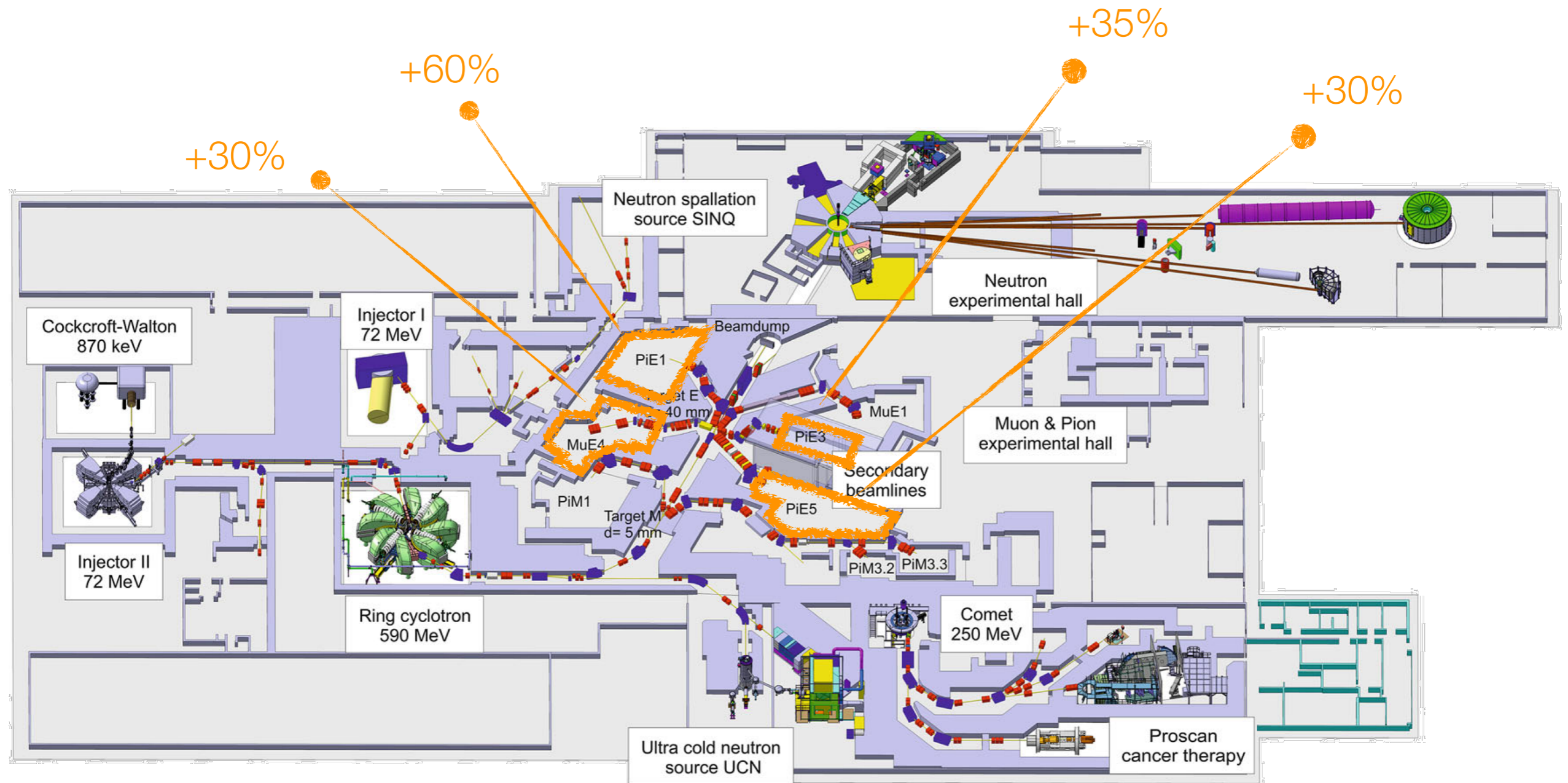

Slanted target: Prototype test

- Expect 30-50 % enhancement
- Measurement foreseen in three directions in 2019

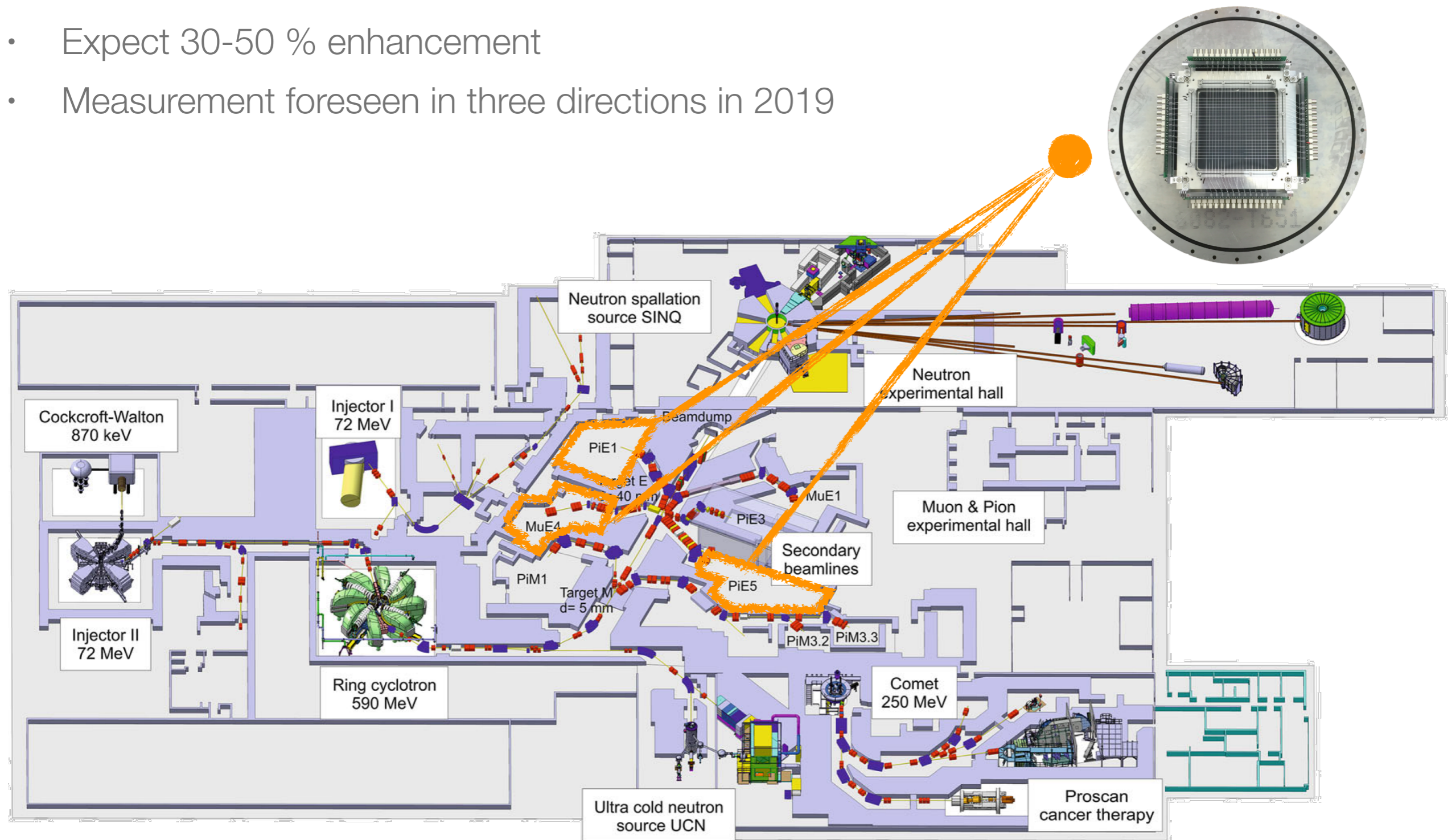

HiMB project @ PSI

- New target station downstream present TgM location
- $\sim 90^\circ$ extraction to existing experimental areas
- Large phase space acceptance solenoidal channel

Target M

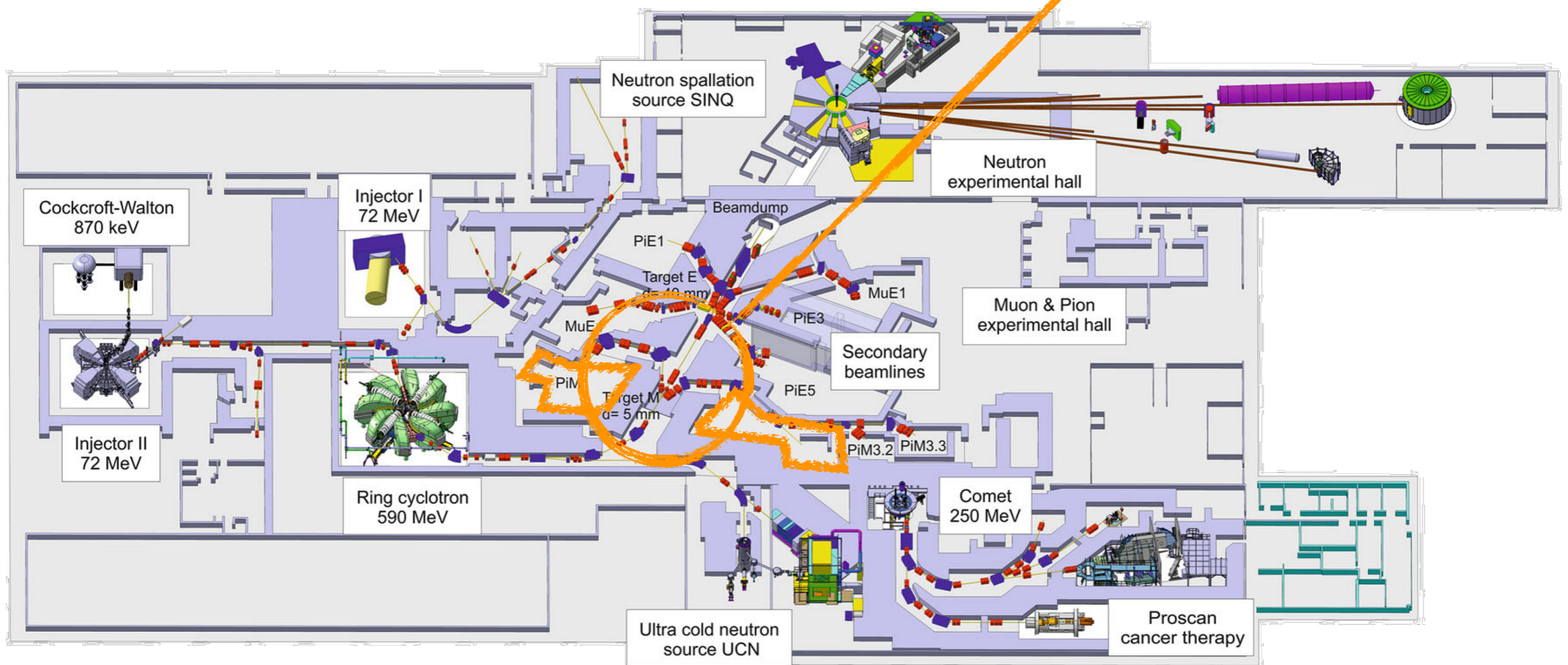

Target geometry for new target M*

- Change current 5 mm TgM for 20 mm TgM*
- 20 mm rotated slab target as efficient as Target E

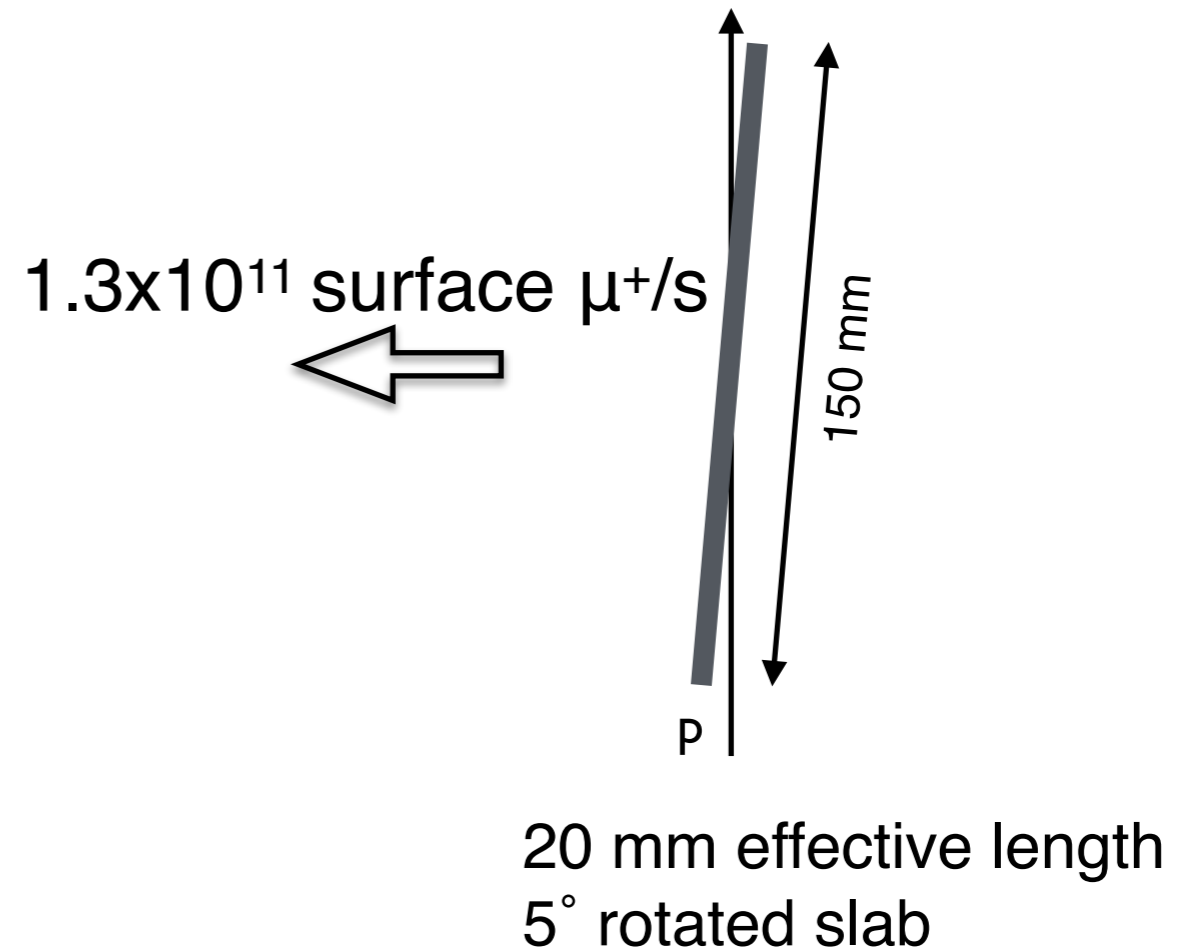
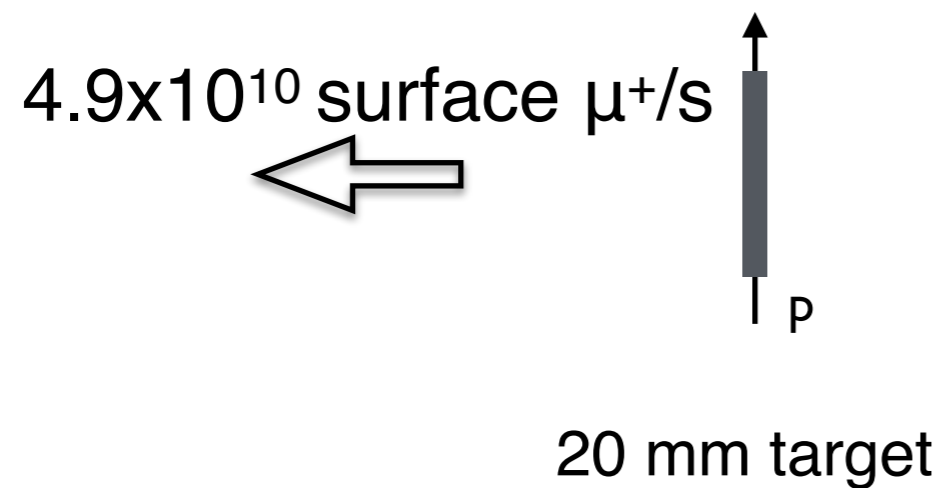

Split capture solenoids

- Two normal-conducting, radiation-hard solenoids close to target to capture surface muons
- Central field of solenoids ~ 0.35 T
- Field at target ~ 0.1 T

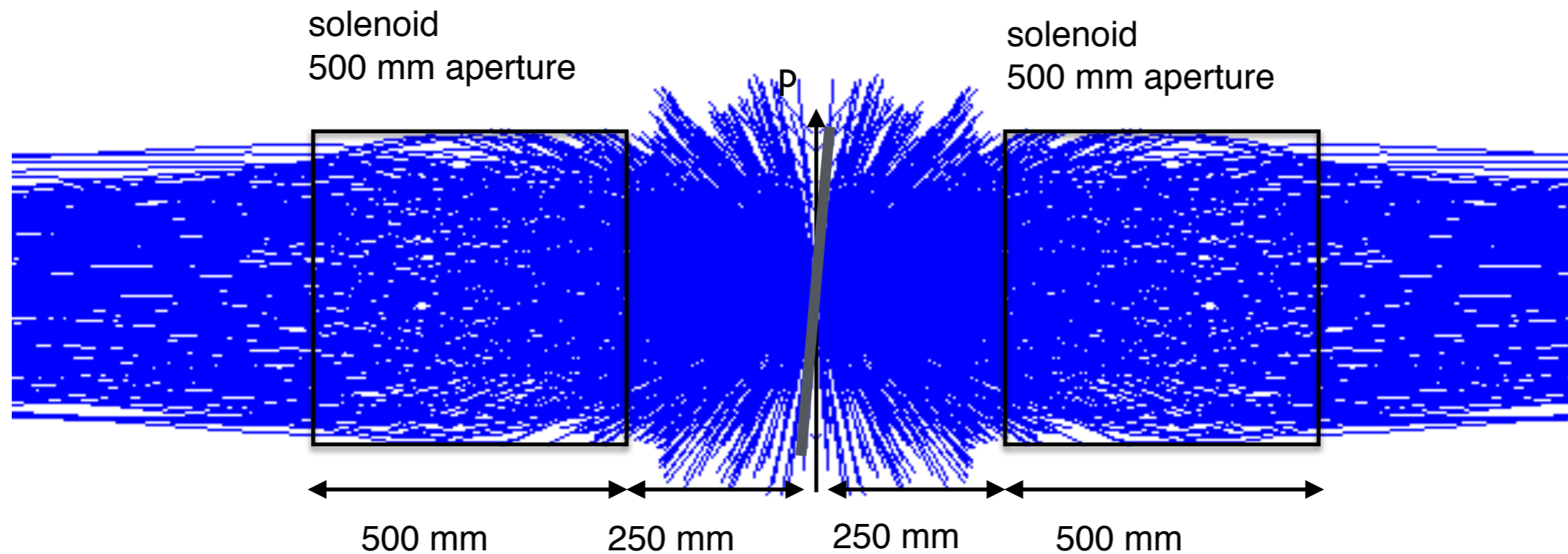

Solenoid beam line

- First version of beam optics showing that large number of muons can be transported.
- Almost parallel beam, no focus, no separator, ...
- Final beam optics under development

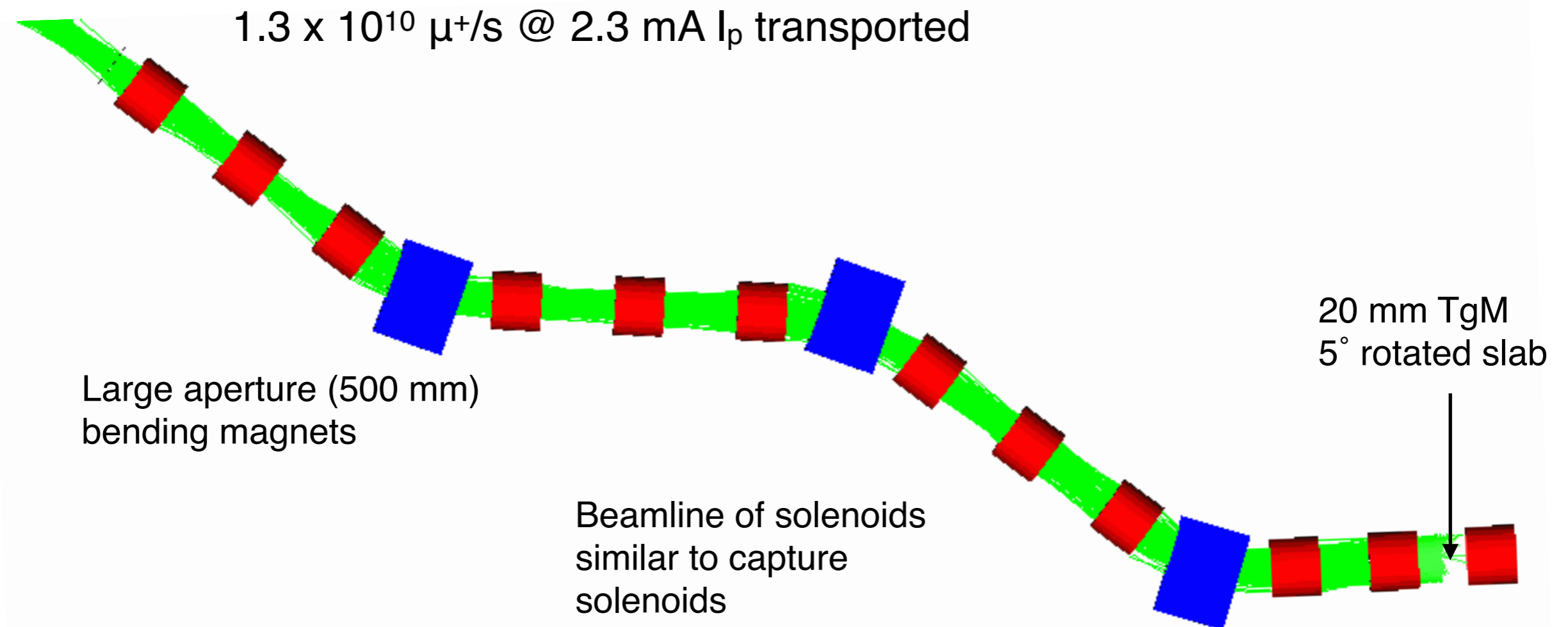

Prospects

- Aim: $O(10^{10})$ muon/s; Surface (positive) muon beam ($p = 28 \text{ MeV}/c$); **DC** beam
- Time schedule: **O(2025)**

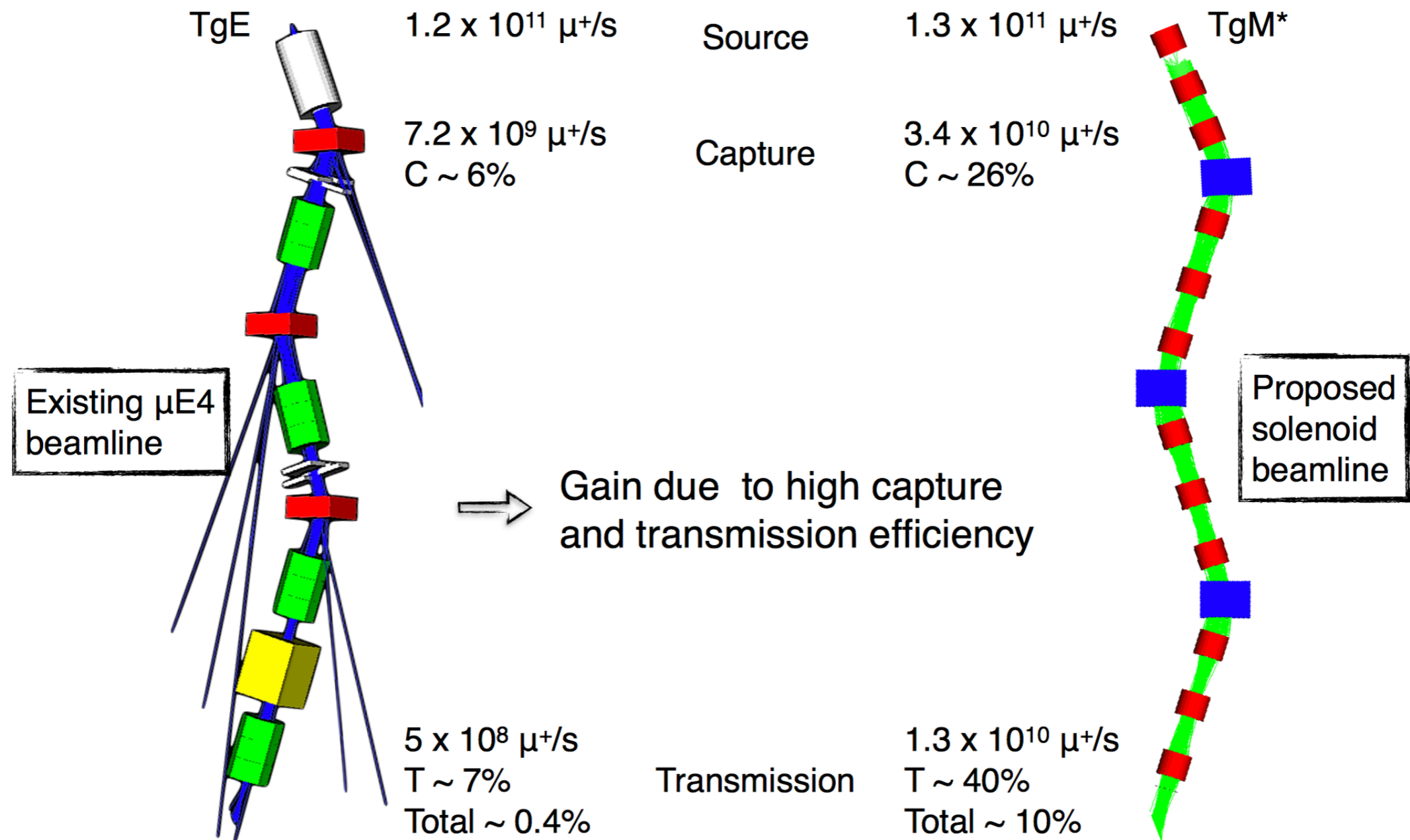

ToDo

- Optimization of capturing
- Optimize final focussing
- Iterative Beam line optimization and implementation of beam monitoring and particle separator locations with max. transmission
- Minimize shielding modifications
- Particle separation
- Investigate impact on proton beam properties
- Study extraction angle
- Determine new target location
- Disposal of highly radioactive waste
- Study Mu3e setup phase space acceptance and optimize final focus properties
- Find solution with current users of Target M

Schematic of the layout in the experimental hall

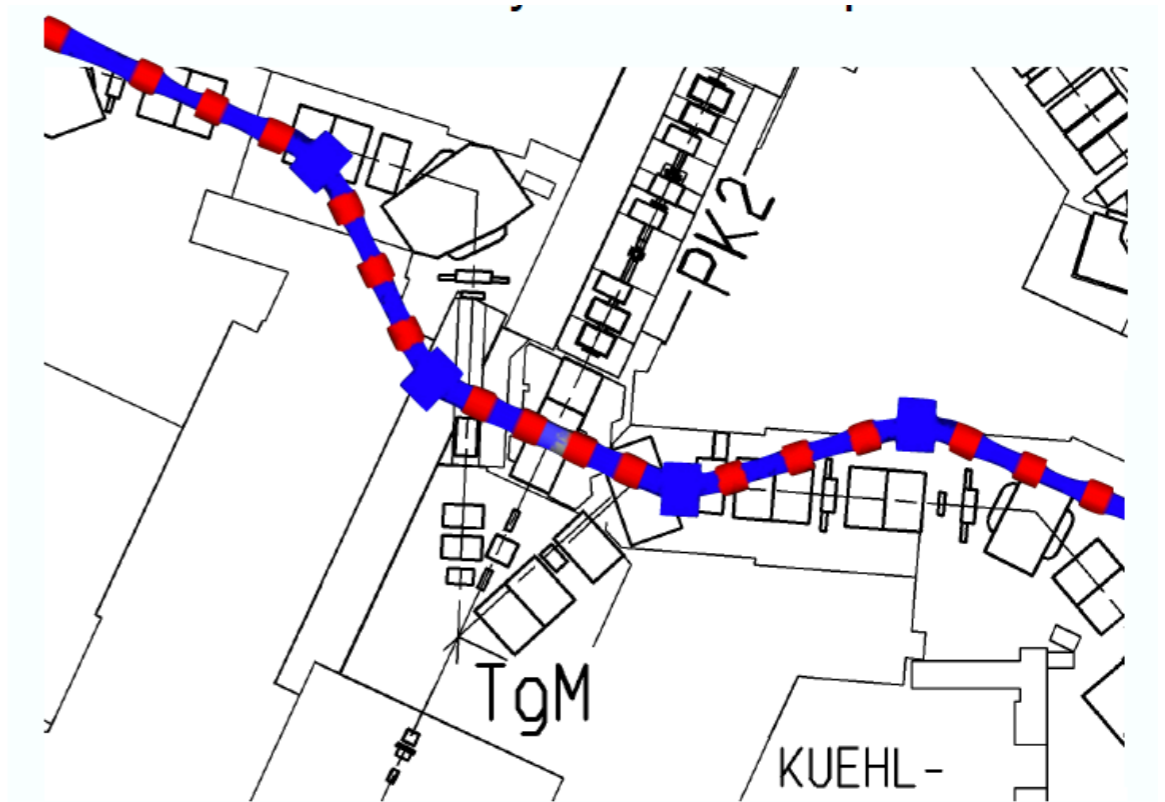

Outlook

- HiMB aims at surface high intensity muon beam **O(10¹⁰ muon/s)**
- Initial simulations show that such rates are feasible
- Beam optics and investigations on proton beam modifications underway
- HiMB opens the door to interesting physics opportunities for particle physics and materials science using high-intensity and high-brightness muon beams (Mu3e Phase II, Low energy MuSR, Muonium spectroscopy, ...)
- Put into perspective the target optimisation only, corresponding to **50%** of muon beam intensity gain, would correspond to effectively raising the proton beam power at PSI by **650 kW**, equivalent to a beam power of almost **2 MW** without the additional complications such as increased energy and radiation deposition into the target and its surroundings
- If the same exercise is repeated put into perspective the beam line optimisation the equivalent beam power would be of the order of **several tens of MW**



Final remarks

- Astonishing sensitivities in muon cLFV channels are foreseen for the incoming future
 - “Lepton & quark session” on Monday afternoon 29 July
- **cLFV remains one of the most exciting place where to search for new physics**
- Submitted inputs to the European Strategy Committee

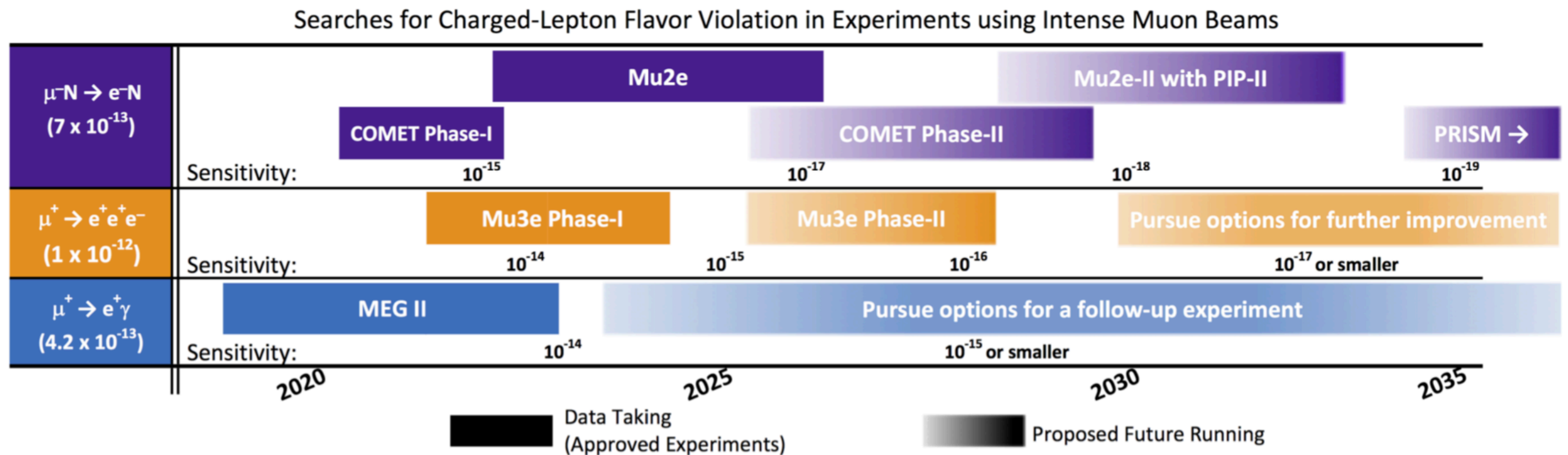

Thanks for your attention!

Optimal surface muon production

- **BUNGAU** et al., Phys. Rev. ST Accel. BEAMS **16**, 014701 (2013)
- Target: graphite
- Simulation validation: ISIS data
- For standalone muon facility: 500 MeV proton energy is the optimal energy

Variation of muon yield with proton energy at higher energies

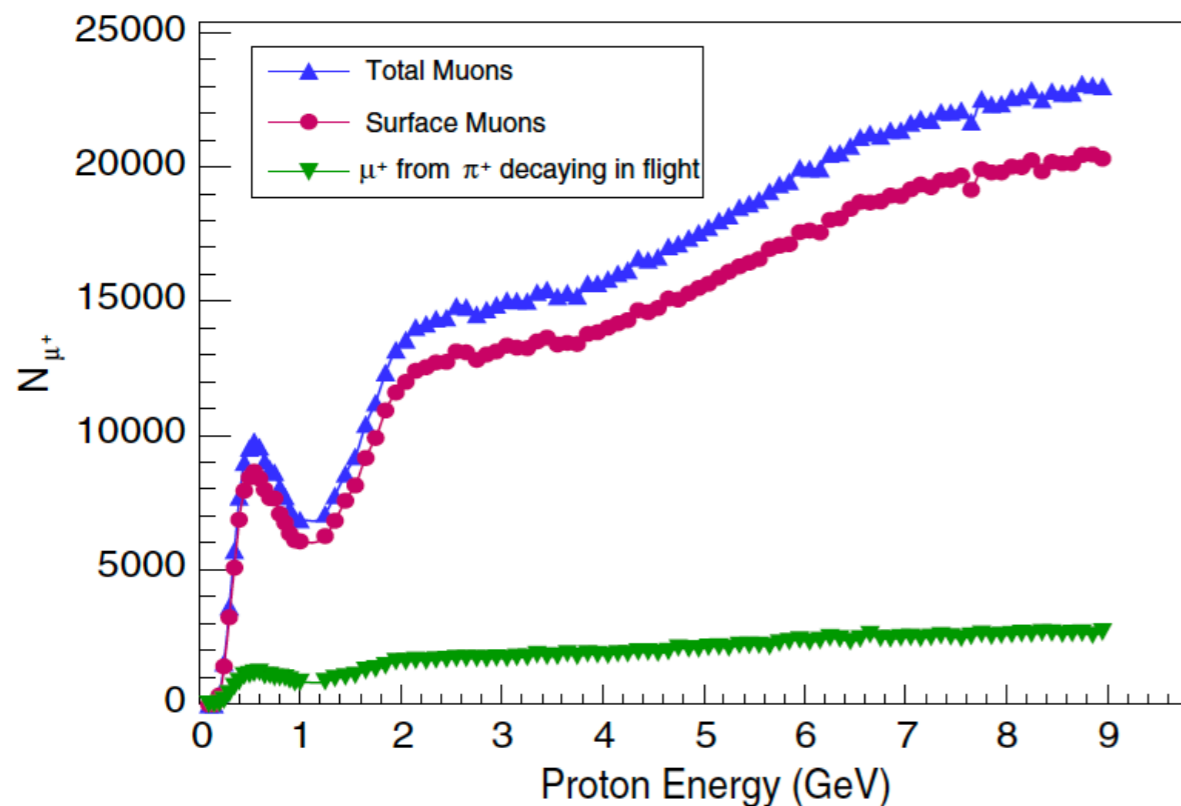

Normalization of the muon yield to the proton energy

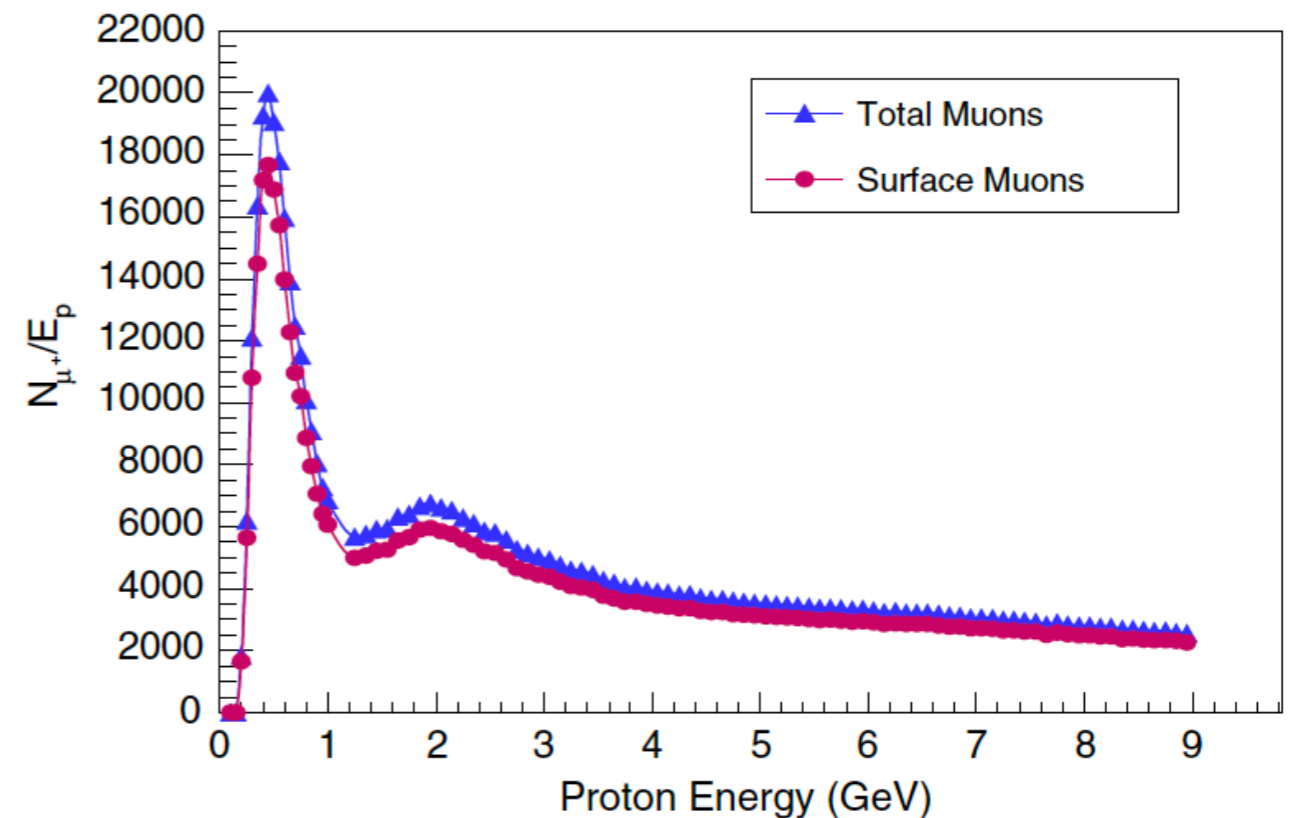

Muon production via pion decay

- Single pion production at 290 MeV proton energy (LAB)
- Low-energy muon beam lines typically tuned to surface- μ^+ at ~ 28 MeV/c
- Note: surface $-\mu \rightarrow$ polarized positively charged muons (spin antiparallel to the momentum)
- Contribution from cloud muons at similar momentum about 100x smaller
- Negative muons only available as cloud muons

