



Cavity & helium vessel preliminary technical drawings

Guillaume OLRÉY
Sebastien ROUSSELOT

Version 1

- Stiffening rings → OK
- Ribs on end cells → NO
- RF coupler integrated inside He vessel → NO

Stresses
on iris

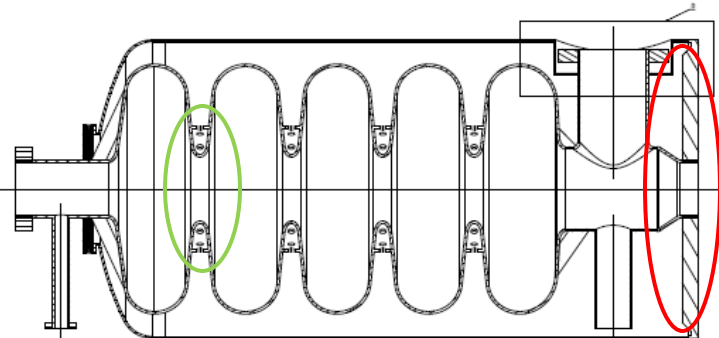
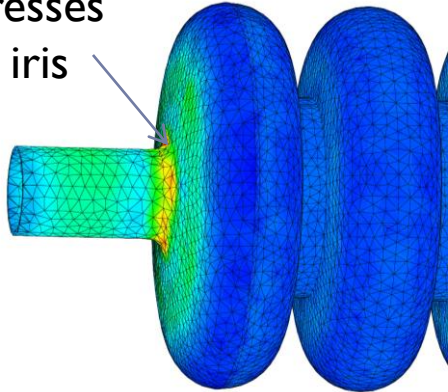

“Ultra”
thick flange

Not enough
space for the
bellows!

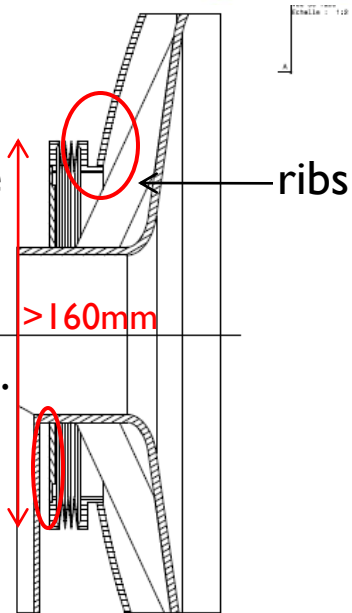

Bellows diam.
Too big!

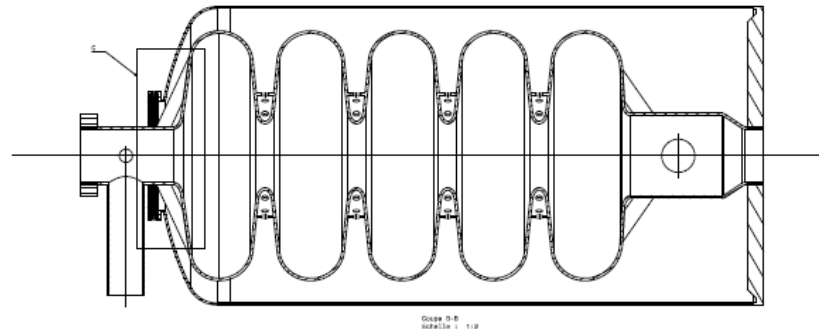
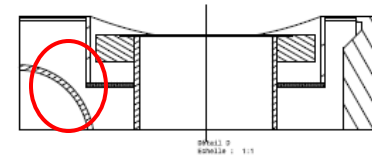

Version 2

- New rib on end cell → NO
- RF coupler not integrated inside He vessel → OK but...not stiff enough

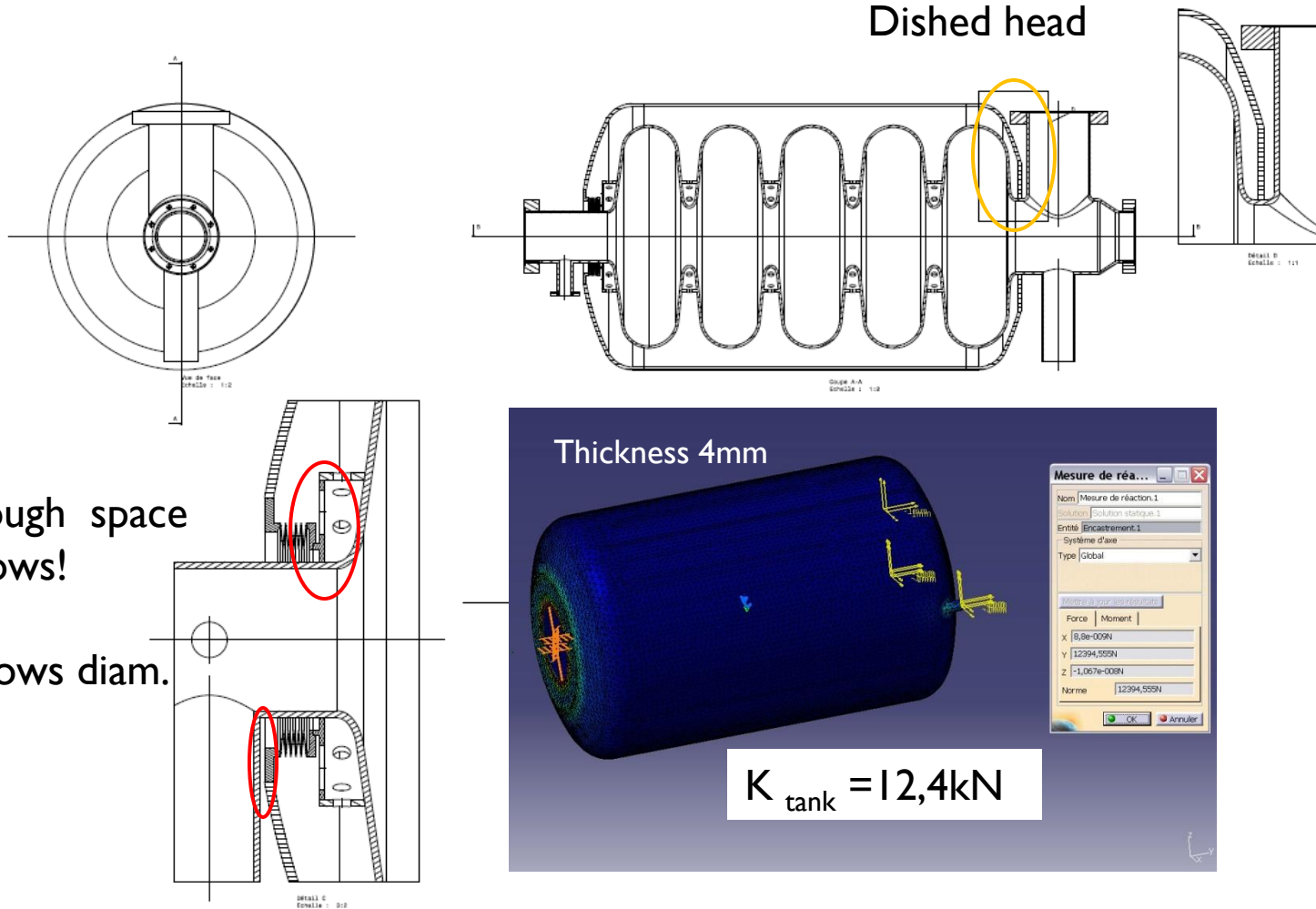

Version 3

- No rib on end cell but thickness 4mm to 5mm → OK
- RF coupler port shifted away 15 mm → OK
- HOM & pick-up ports + Tuning system fixing points → OK

Nb thickness 4mm → 5mm

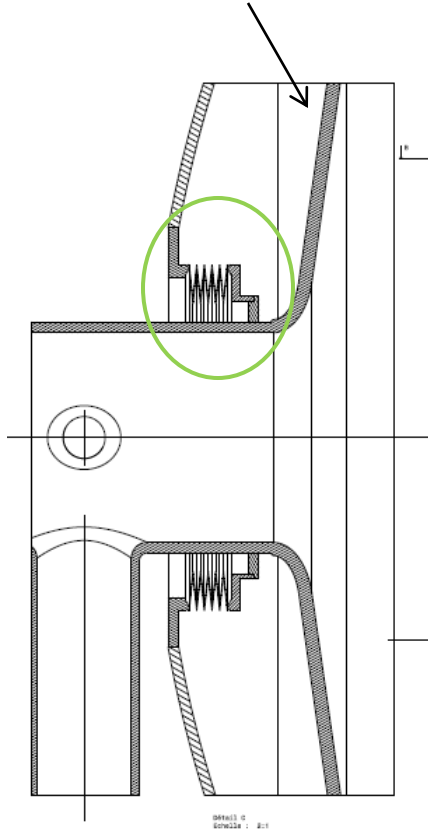

Lcavity + 15mm

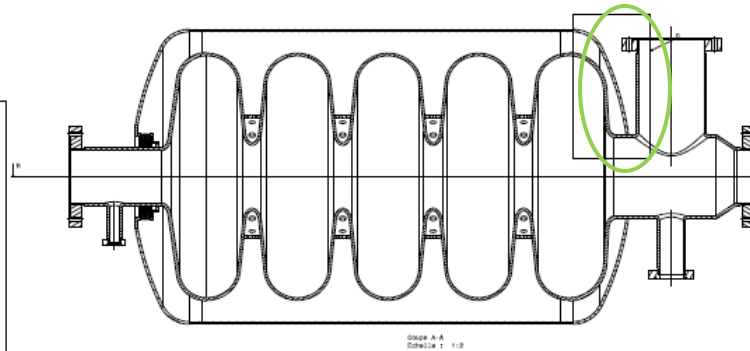

Tuning system fixing points

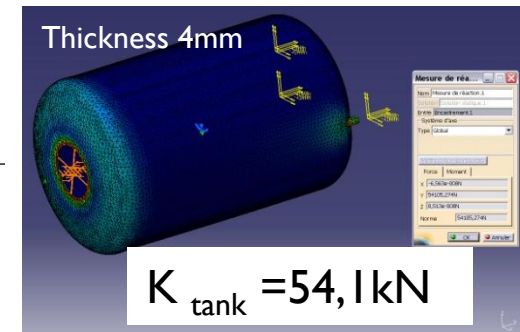
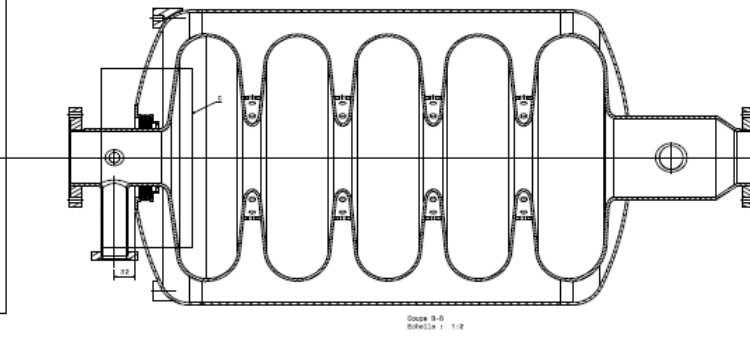
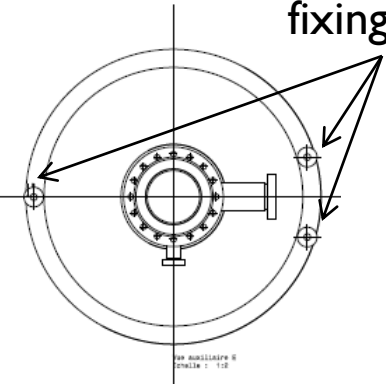

échelle : 2:1

Qext

