

Toward the Frontiers of Particle Physics with the Muon $g-2$ Experiment

Eremey Valetov

Shanghai Jiao Tong University | Michigan State University

On behalf of the Muon $g-2$ Collaboration



上海交通大学
SHANGHAI JIAO TONG UNIVERSITY



李政道研究所
Tsung-Dao Lee Institute

MICHIGAN STATE
UNIVERSITY



U.S. DEPARTMENT OF
ENERGY

Office of
Science

Introduction

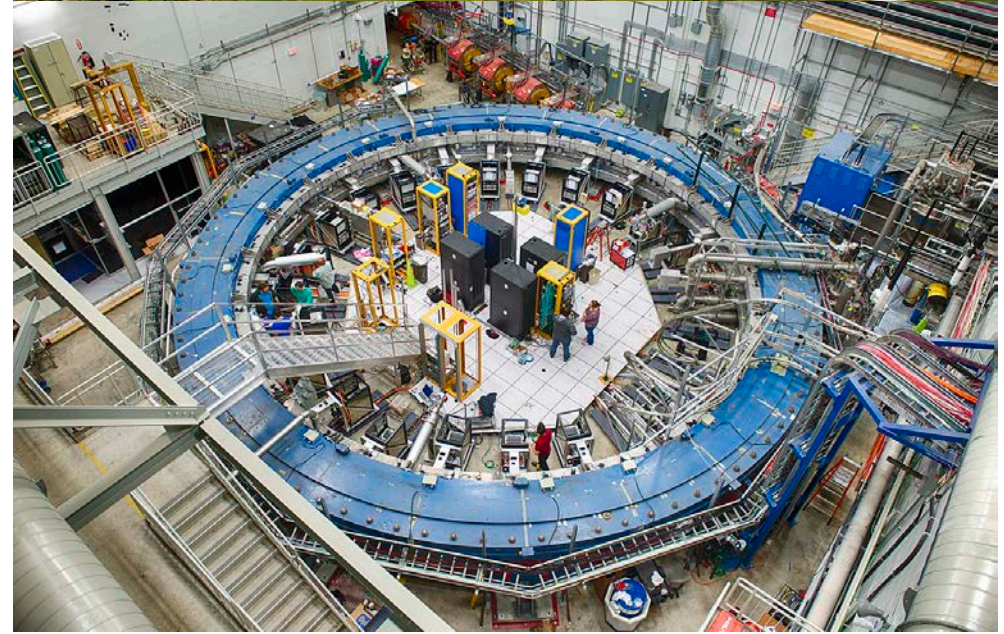
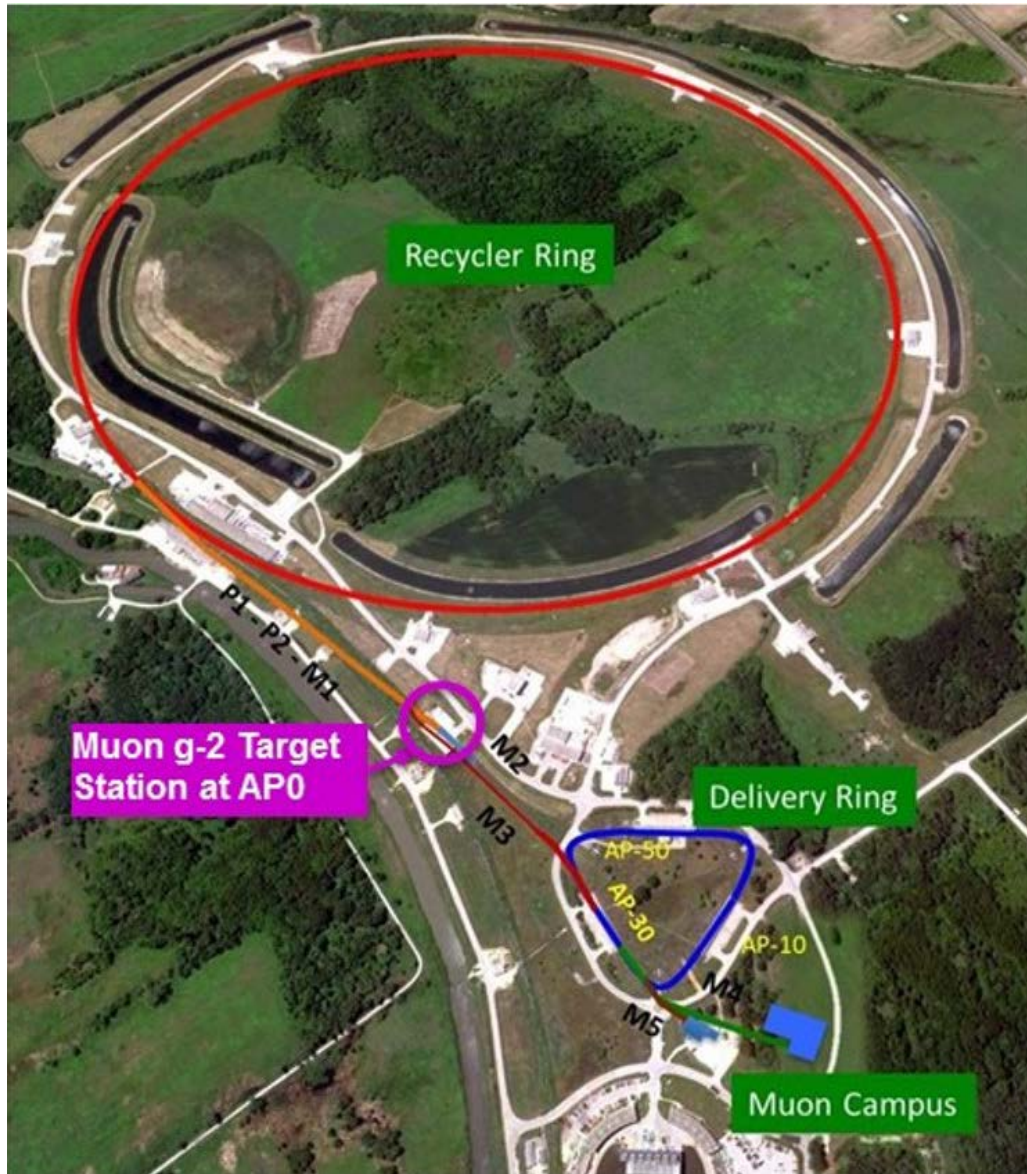

$$\mu = g \frac{e}{2m} s$$

Classical: $g = 1$

Dirac Equation: $g = 2$

$$i \left(\partial_\mu - ieA_\mu(x) \right) \gamma^\mu \psi(x) = m\psi(x)$$

Interactions w/ quantum foam: $g > 2$ $a_\mu = \frac{g-2}{2}$

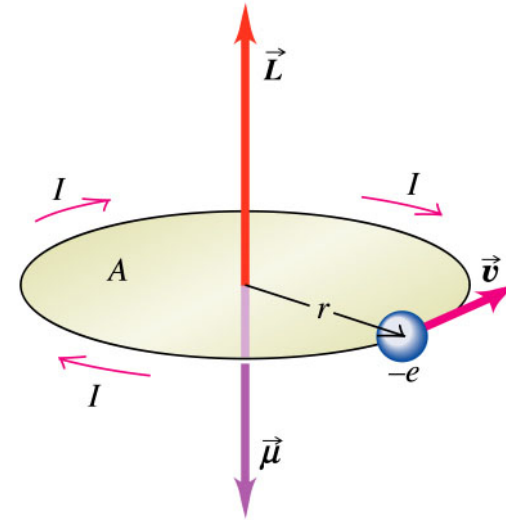

Contributions to a_μ in the Standard Model

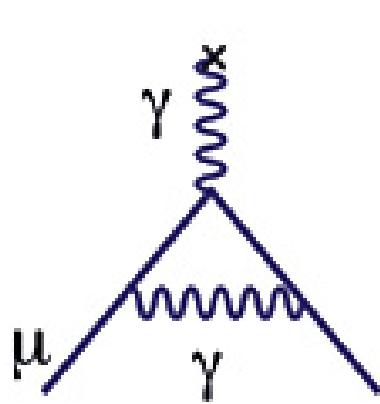

QED

QED incl. 4-loops + 5-loops
 $a_\mu = 116\,584\,718.86 \times 10^{-11}$
 $\delta a_\mu = 0.03 \times 10^{-11}$

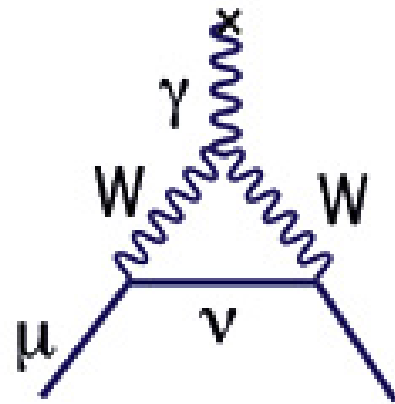

electroweak

Weak to 2-loops
 $a_\mu = 153.6 \times 10^{-11}$
 $\delta a_\mu = 1.1 \times 10^{-11}$

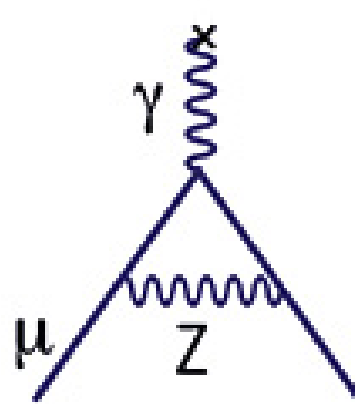

LO hadronic

Hadronic LO VP
 $a_\mu = 6\,894.6 \times 10^{-11}$
 $\delta a_\mu = 32.5 \times 10^{-11}$

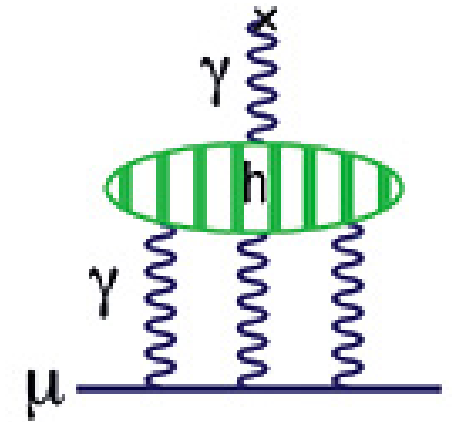

hadronic LbL

Hadronic LbL
 $a_\mu = 103.4 \times 10^{-11}$
 $\delta a_\mu = 28.8 \times 10^{-11}$

Theory: $(11\,659\,1783 \pm 43) \times 10^{-11}$
 Experiment: $(11\,659\,2091 \pm 63) \times 10^{-11}$

Recent Advances in the Theory

Improvements in $a_\mu^{\text{Had, LO VP}}$ (KNT18)

Direct energy scan: CMD-3, SND, KEDR

Radiative return: BABAR, KLOE/KLOE-2, BESIII

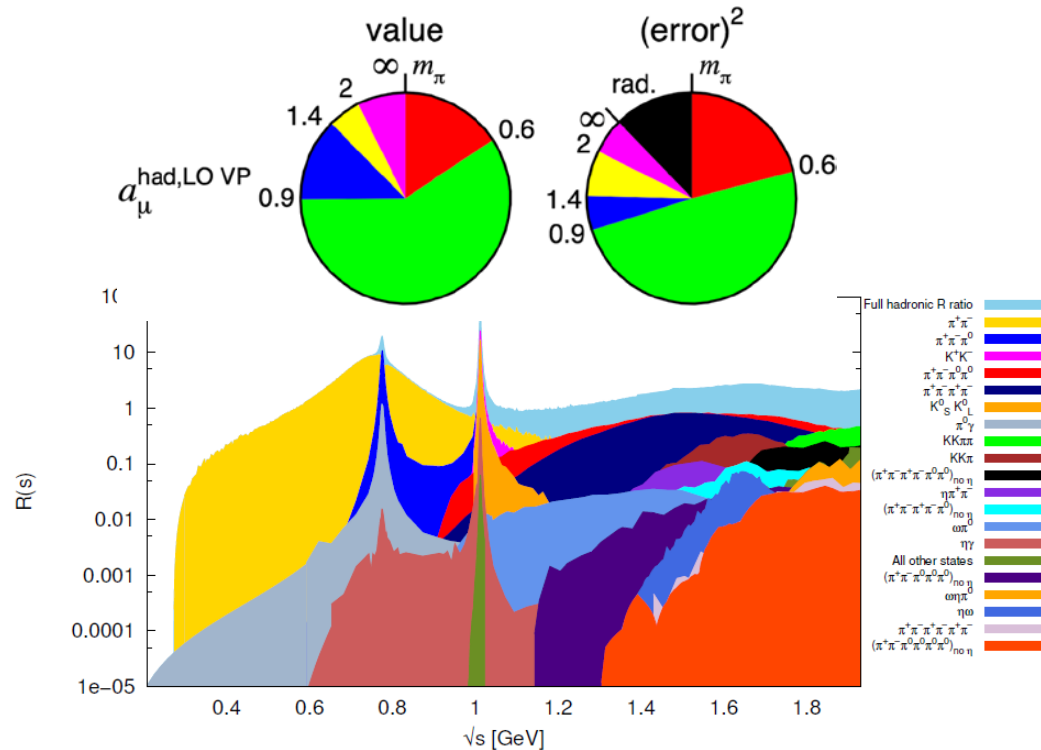

$$a_\mu^{\text{Had,LO VP}} = (693.26 \pm 2.46) \times 10^{-10}$$

A. Keshavarzi, D. Nomura and T. Teubner, Phys. Rev. D **97**, no. 11, 114025 (2018).

Calculation of $a_\mu^{\text{Had, VP}}$ and $a_\mu^{\text{Had, LbL}}$ using Lattice QCD

- From first principles
- Can be used to improve R-ratio results
- Several collaborations working on this
 - including RBC/UKQCD and Mainz
- Precision needs improvement; calculations ongoing

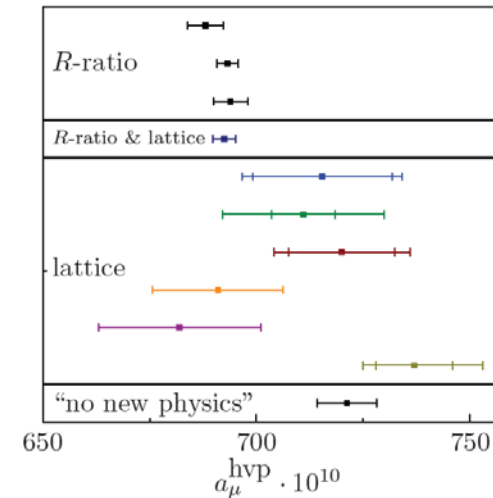

V. Gülpers, arXiv:2001.11898 [hep-lat] (2020).

Beyond-Standard Model Possibilities

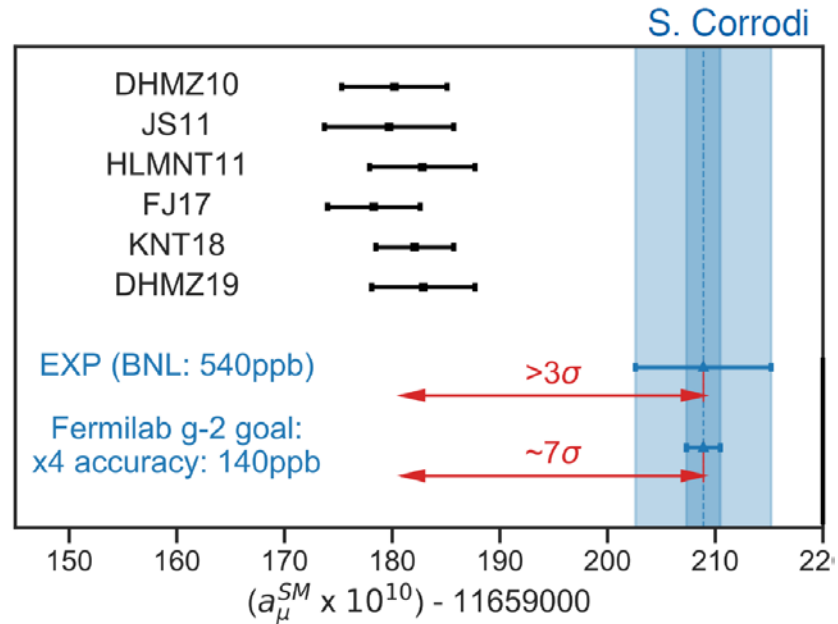

In case of a Beyond-SM a_μ , some of the possible contributors to the respective discrepancy would be:

- Dark matter
- Supersymmetry (SUSY)
- Extra dimensions
- Additional Higgs Bosons
[S. Iguro *et al.*, arXiv:1907.09845 [hep-ph]]

Muon $g-2$ window in the search for inelastic dark matter (iDM) :

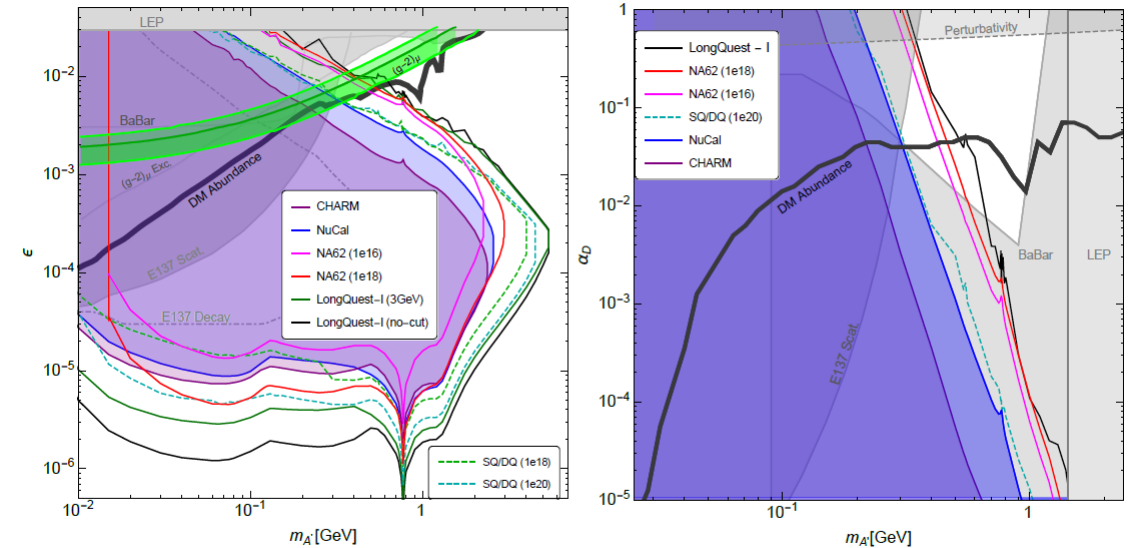

(a) iDM: $\Delta = 0.4, \alpha_D = 0.1$. With muon $g-2$ and DM regimes. (b) iDM Muon $g-2$ Target: $\Delta = 0.4, \epsilon = \epsilon_{(g-2)_\mu}$.

(α_D : analogue of the fine structure constant for a new $U(1)$ gauge symmetry $U(1)_D$. Δ : mass splitting $\Delta = \frac{(m_2 - m_1)}{m_1}$.)

NA62 Experiment at CERN is ongoing and may yield iDM results.

See Y.-D. Tsai *et al.*, arXiv:1908.07525 [hep-ph] (2019).

Citations of Publications of the Muon g-2 Experiment at BNL

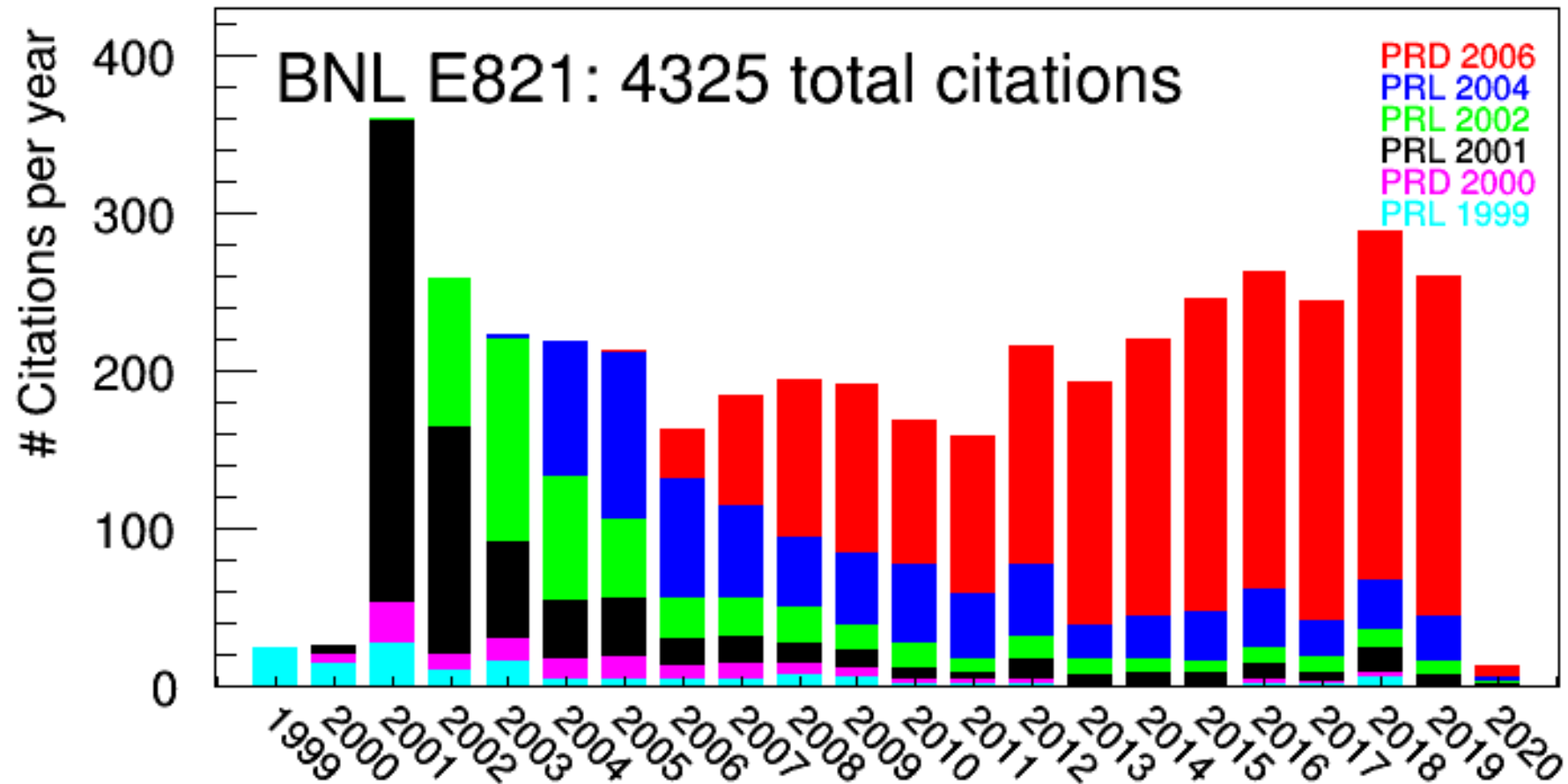

The Muon g-2 Experiment at Fermilab (E989)

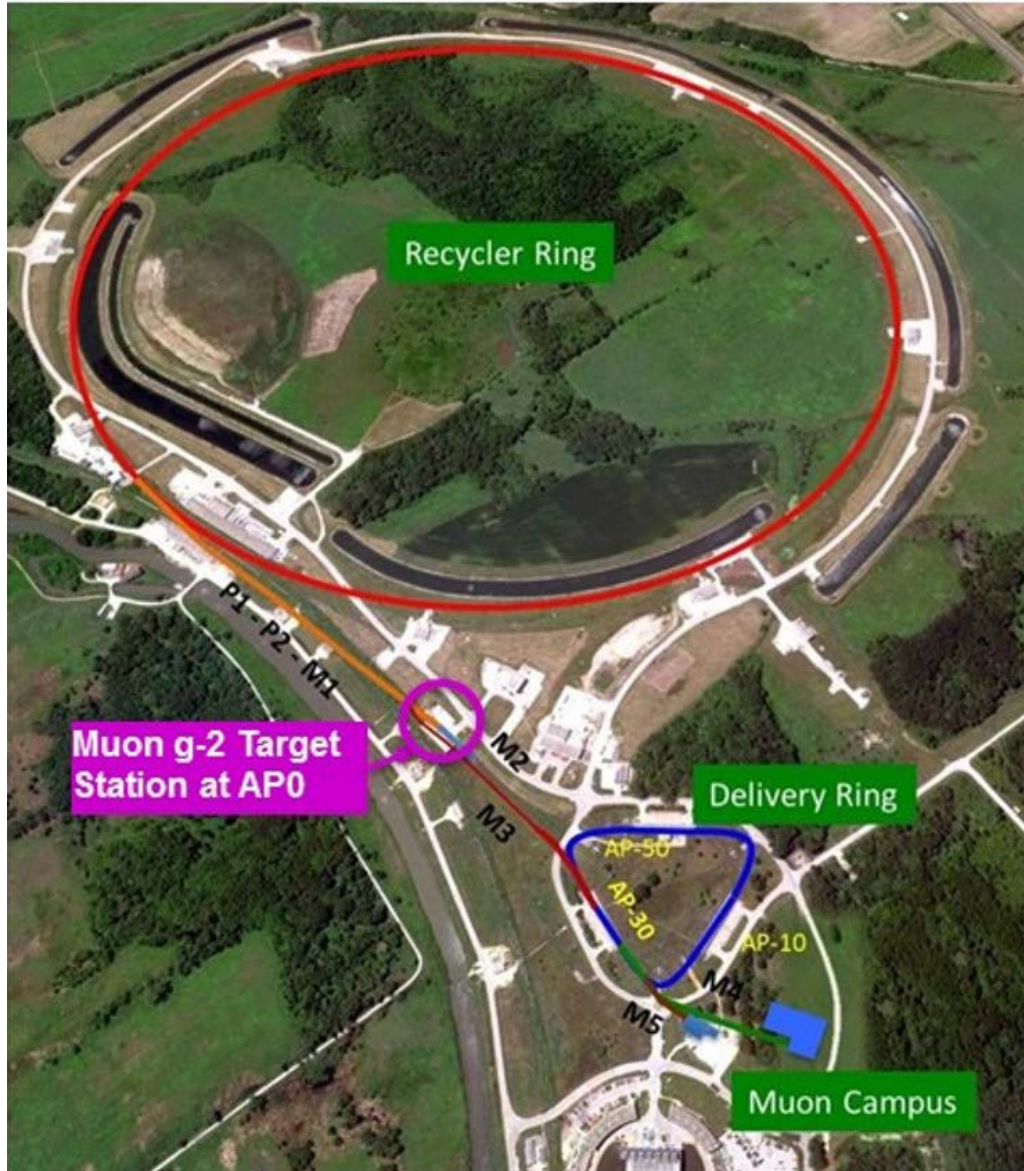

Improvements over the Muon g-2 Experiment at BNL (E821):

- More muons, delivered more often to the storage ring
- Improved muon storage function
- Better beam dynamics modeling
- Higher field uniformity and better field monitoring
- Reduced spin precession frequency systematics

The Great Move

2013

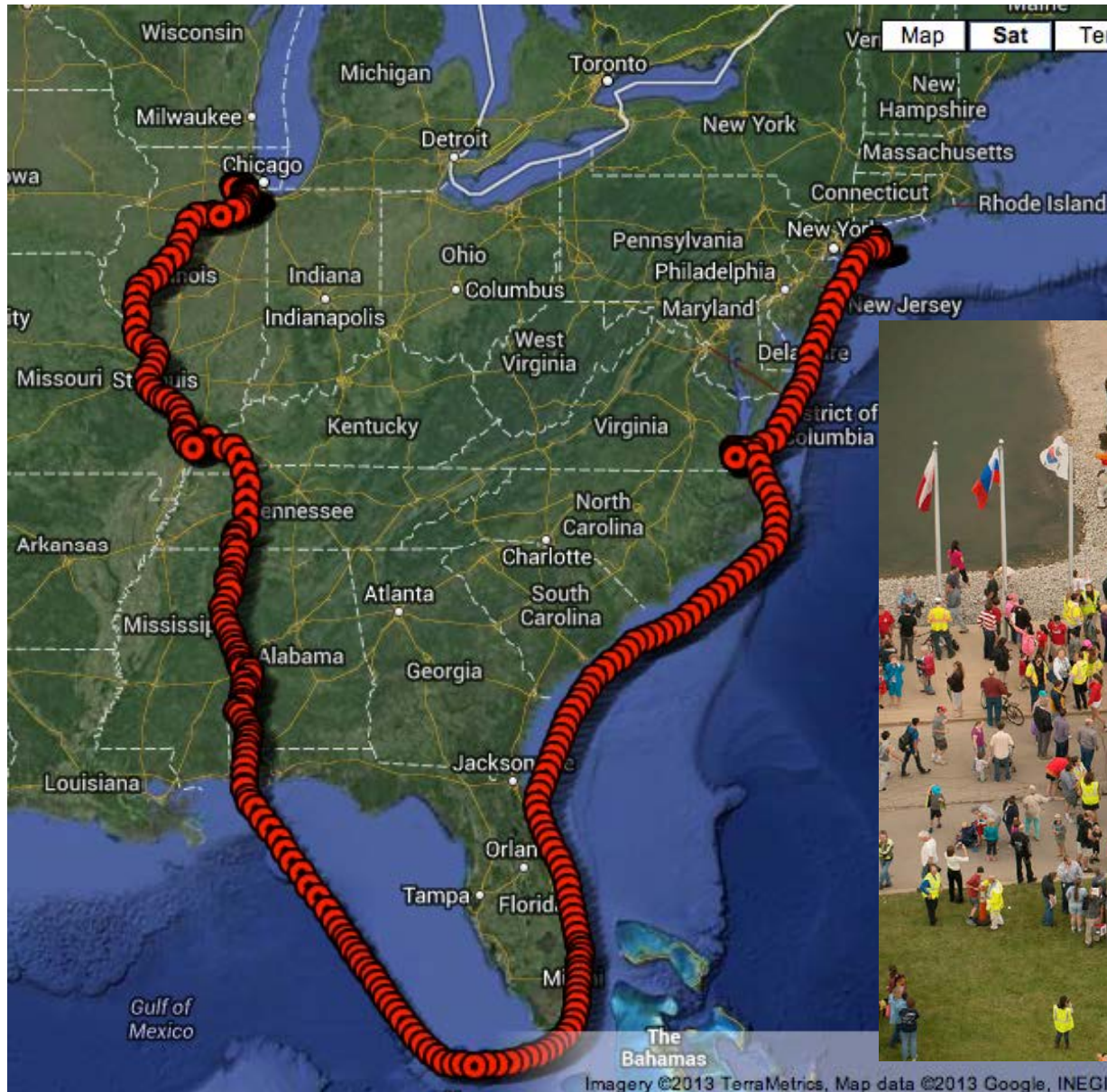

The Muon g-2 Experiment at Fermilab (E989)

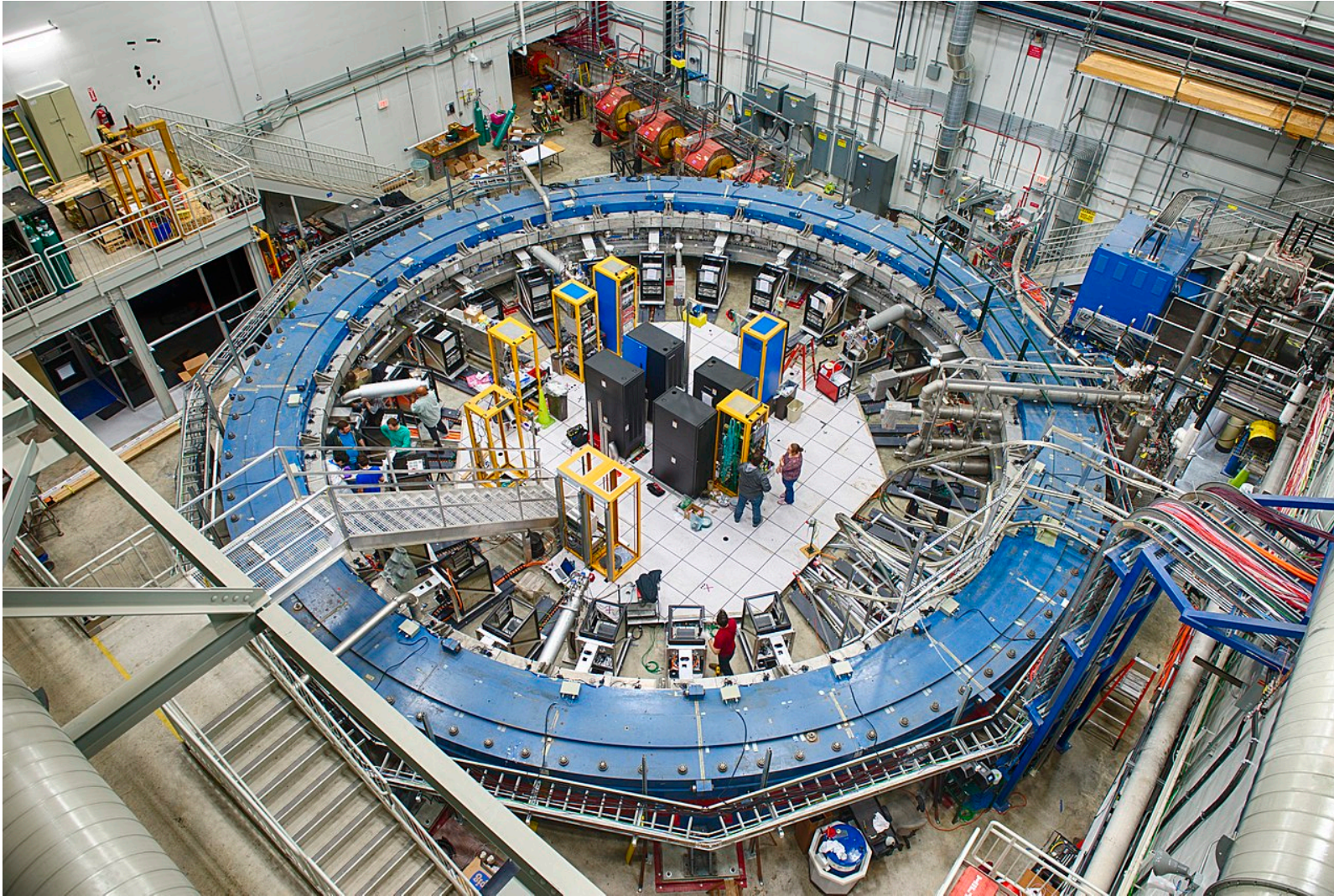

Technical design projection:

- ~20x more data
- ~3x reduction of systematic errors

The Muon g-2 Storage Ring

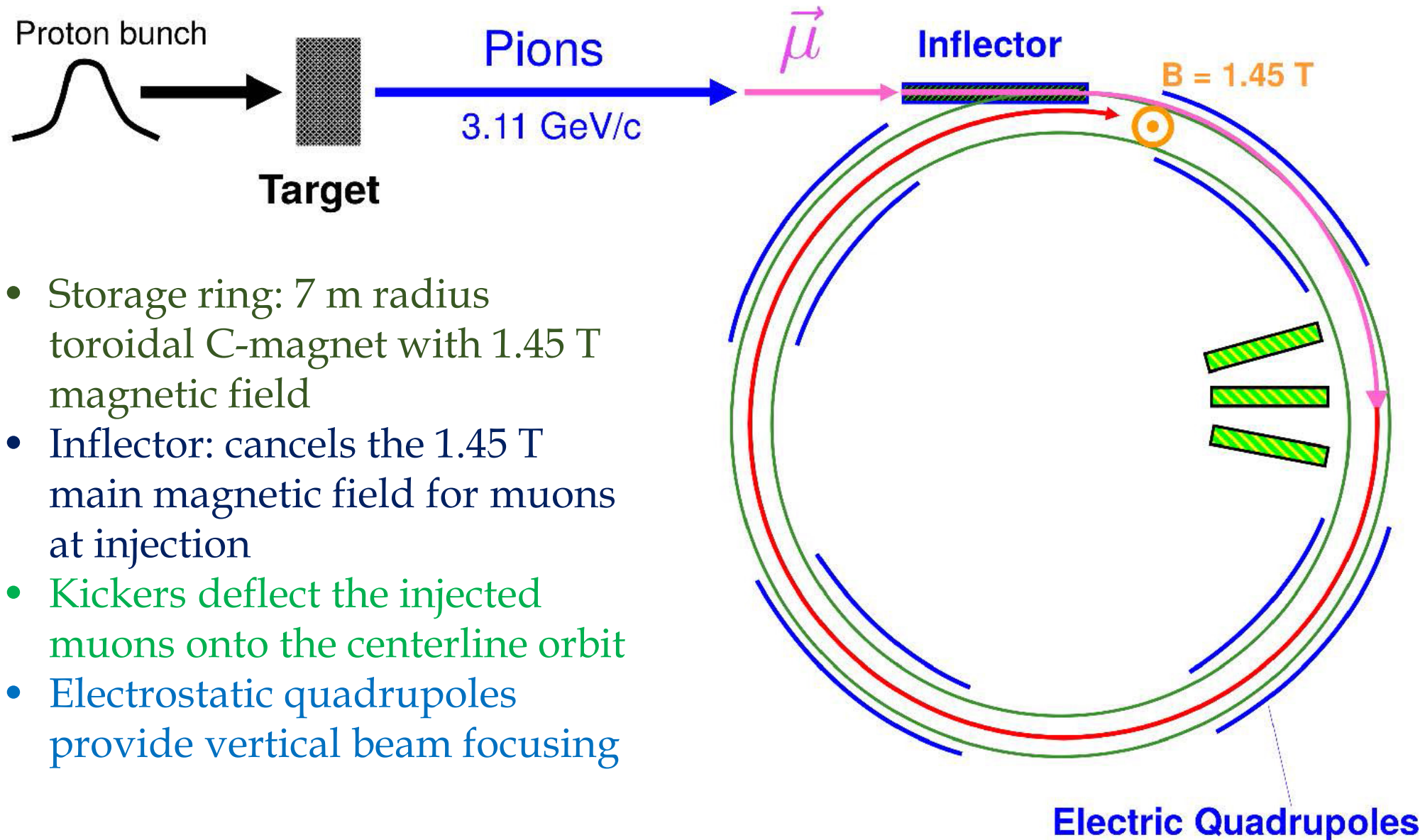

- Storage ring: 7 m radius toroidal C-magnet with 1.45 T magnetic field
- Inflector: cancels the 1.45 T main magnetic field for muons at injection
- Kickers deflect the injected muons onto the centerline orbit
- Electrostatic quadrupoles provide vertical beam focusing

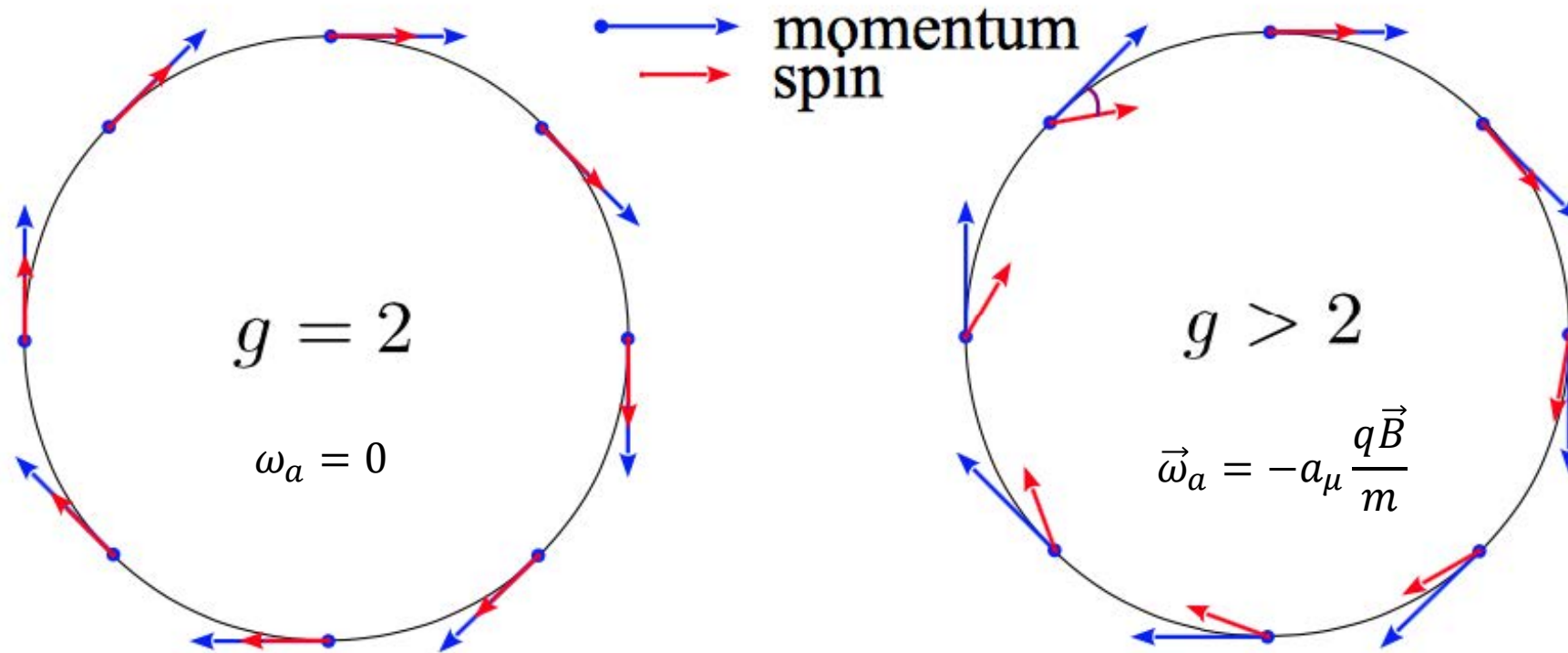

If $g=2$, the angle between the magnetic moment and the momentum does not change.
If $g>2$, the angle between the magnetic moment and the momentum changes linearly.

Measurement of Muon Spin Precession

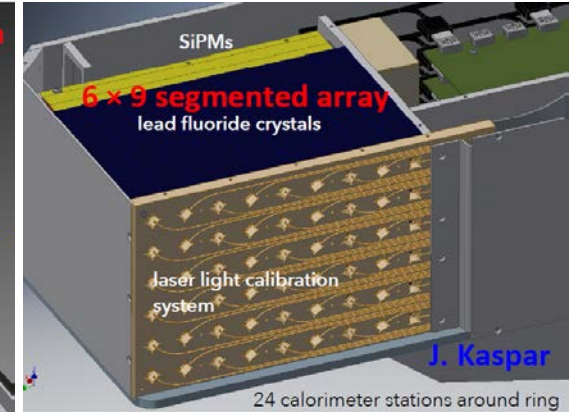
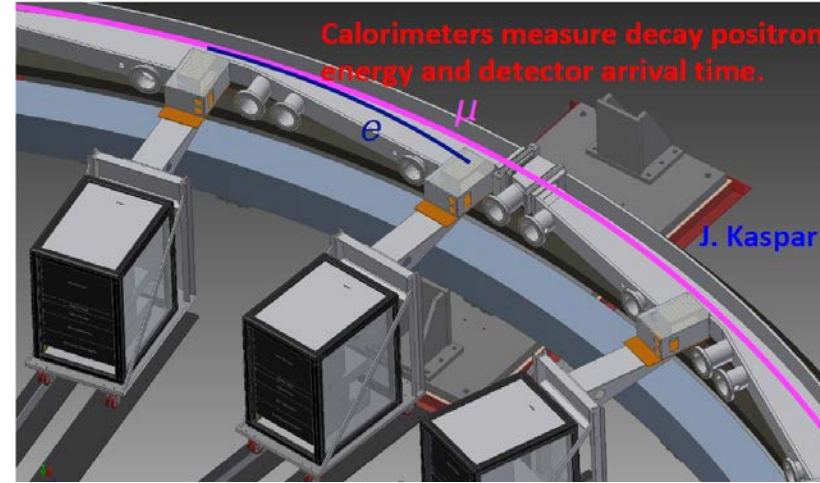

Crystals are 25×25×140 mm

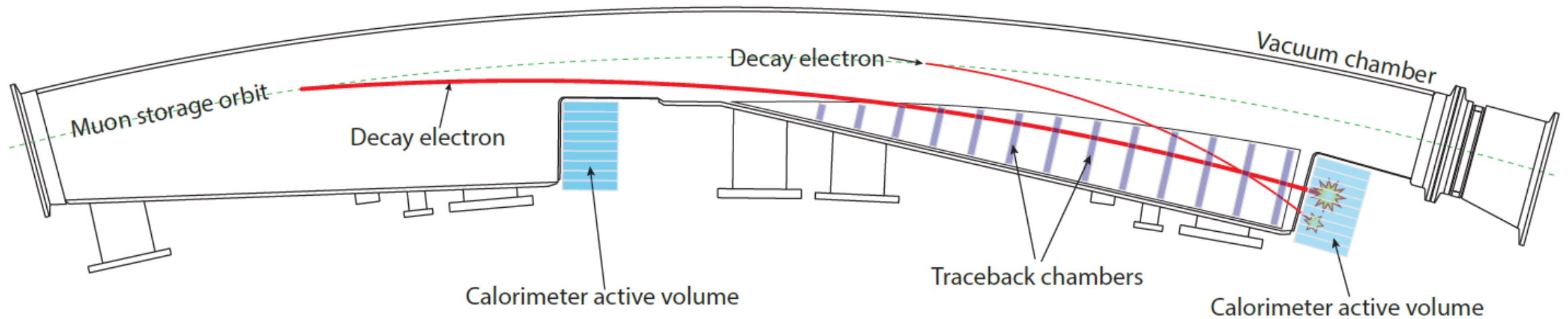

Straw trackers: reconstruct decay e^+ trajectories
Calorimeters: detect decay e^+ energy and arrival times

The Wobble Plot

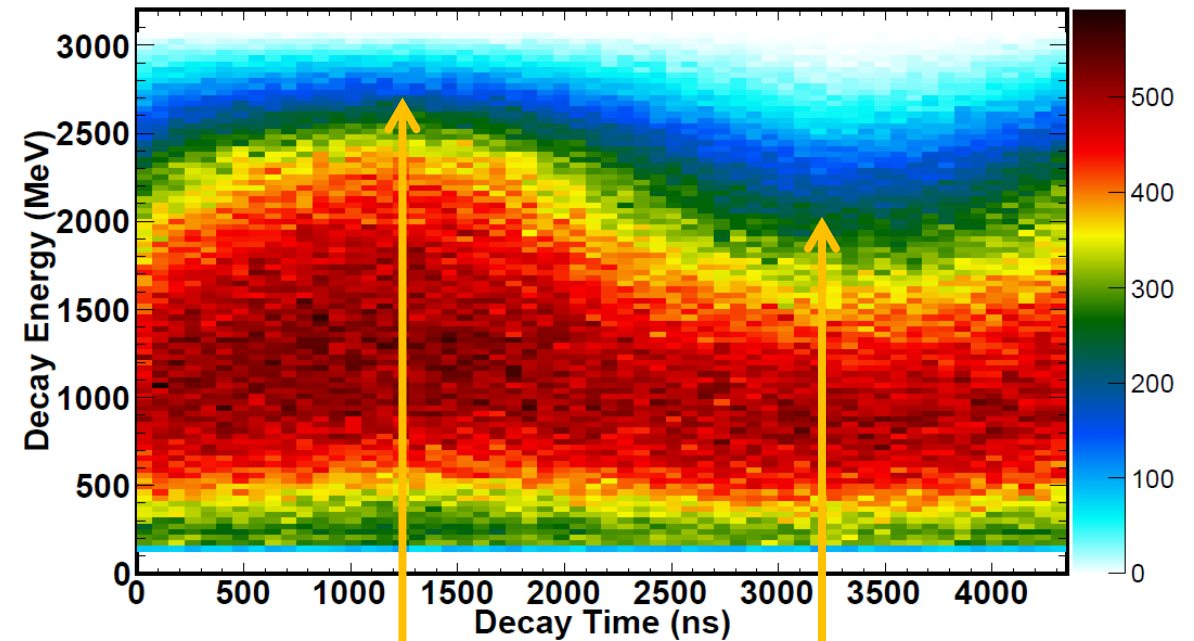
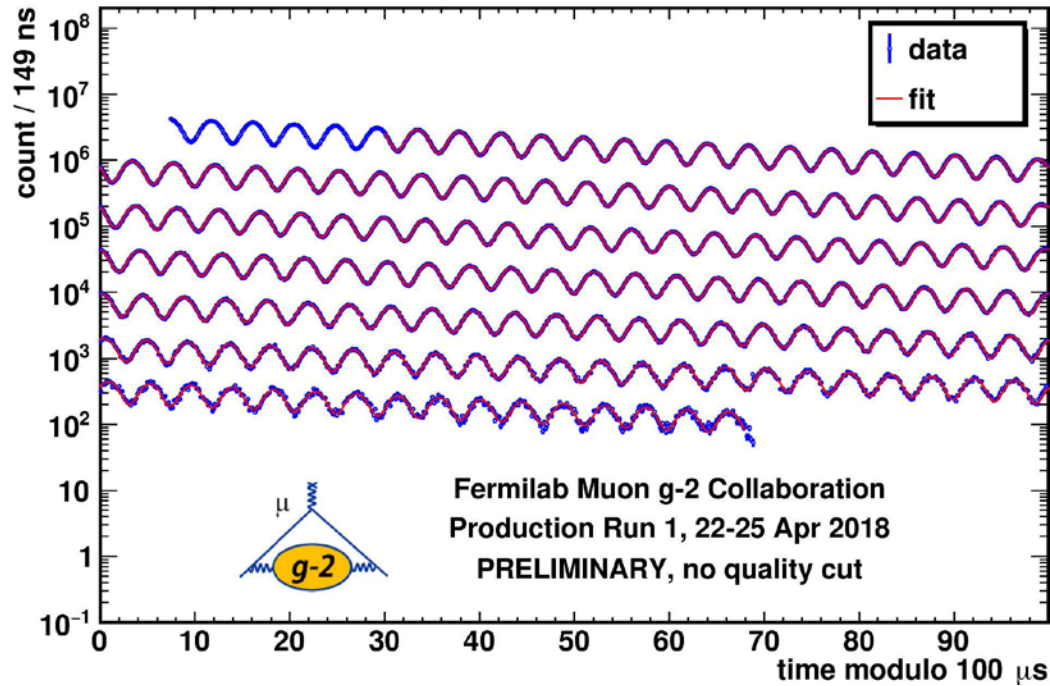

Muon spin and momentum
are aligned.

Muon spin and momentum
are anti-aligned.

$$f(t) = N_0 e^{-\lambda t} [1 + A \cos(\omega_a t + \phi)]$$

λ : exponential decay constant

ω_a : muon anomalous precession frequency

Early-to-late phase change:

If, $\phi = \phi(t) = \phi_0 + \phi_1 t$, then

$$\begin{aligned} \cos(\omega_a t + \phi) &= \cos(\omega_a t + \phi_0 + \phi_1 t) = \\ &= \cos((\omega_a + \phi_1)t + \phi_0) \end{aligned}$$

Calculation of a_μ from Muon and Proton Spin Precession

from decay e^+ time spectra

$$a_\mu = \frac{g_e \frac{m_\mu}{m_e} \omega_a}{2 \langle \omega_p \rangle} \frac{\mu_e}{\mu_p}$$

(140 ppb)

(70 ppb sys. 100 ppb stat.)

(70 ppb sys.)

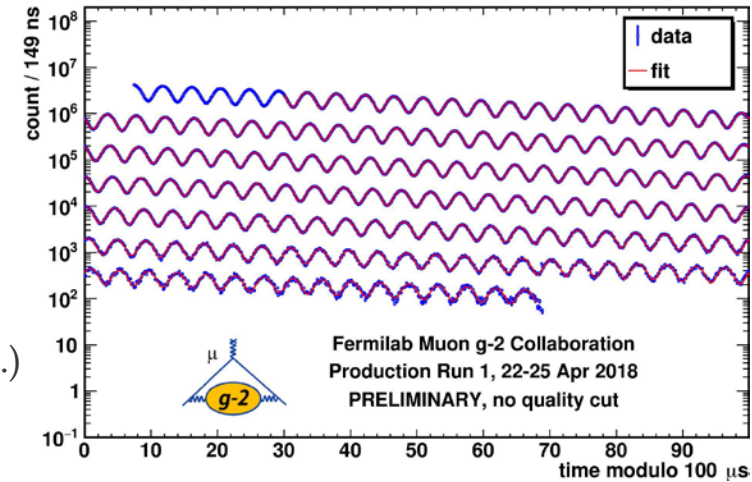

from NMR

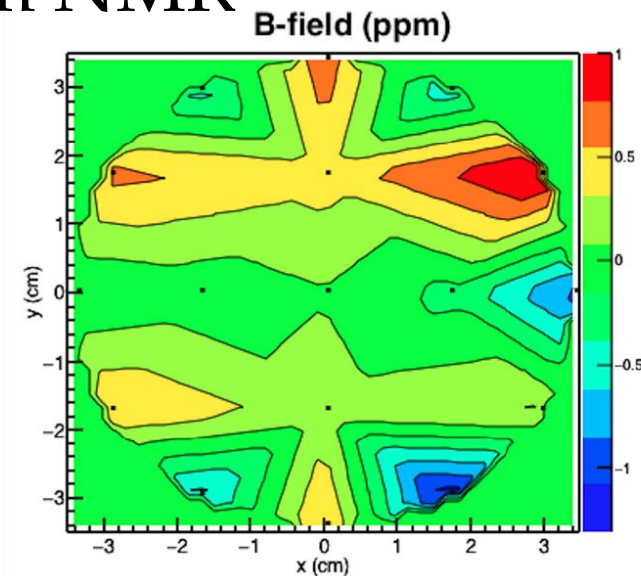

From CODATA [1]:

$$g_e = -2.002\,319\,304\,361\,82(52) \text{ (0.00026 ppb)}$$

$$m_\mu/m_e = 206.768\,2826(46) \text{ (22 ppb)}$$

$$\mu_e/\mu_p = -658.210\,6866(20) \text{ (3.0 ppb)}$$

[1] P. J. Mohr, D. B. Newell and B. N. Taylor, Rev. Mod. Phys. 88, no. 3, 035009 (2016).

Magnetic Field Shimming

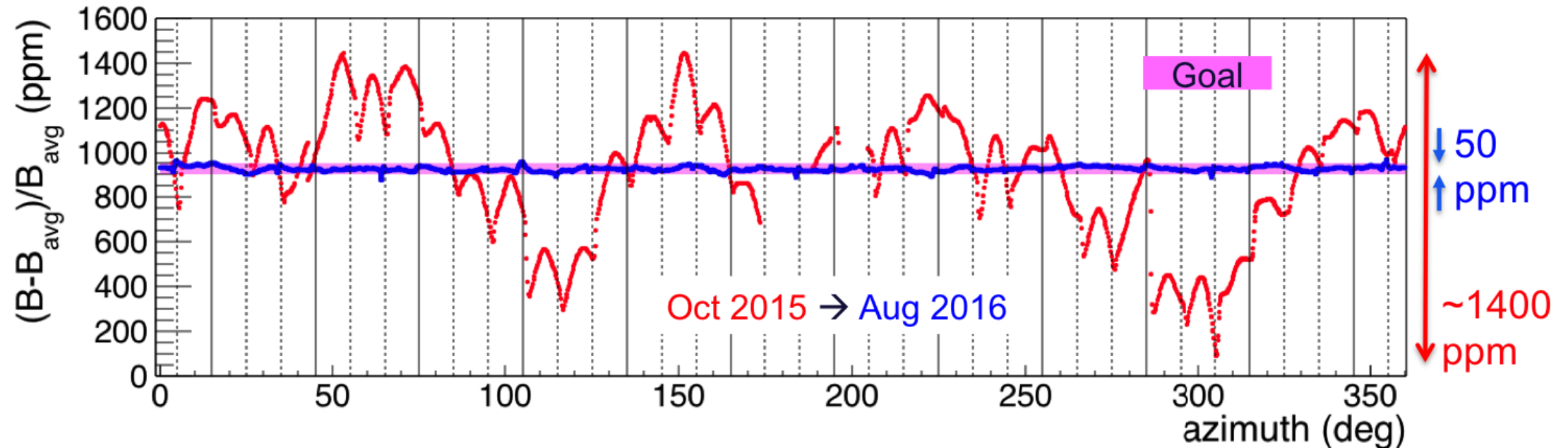

- Passive shimming is performed by inserting tiny metal pieces to increase the field.
- Magnetic field was made 3x more uniform than at BNL.
- Active shimming is also used.

Fixed and Trolley-Mounted NMR Probes

Fixed probes on vacuum chambers

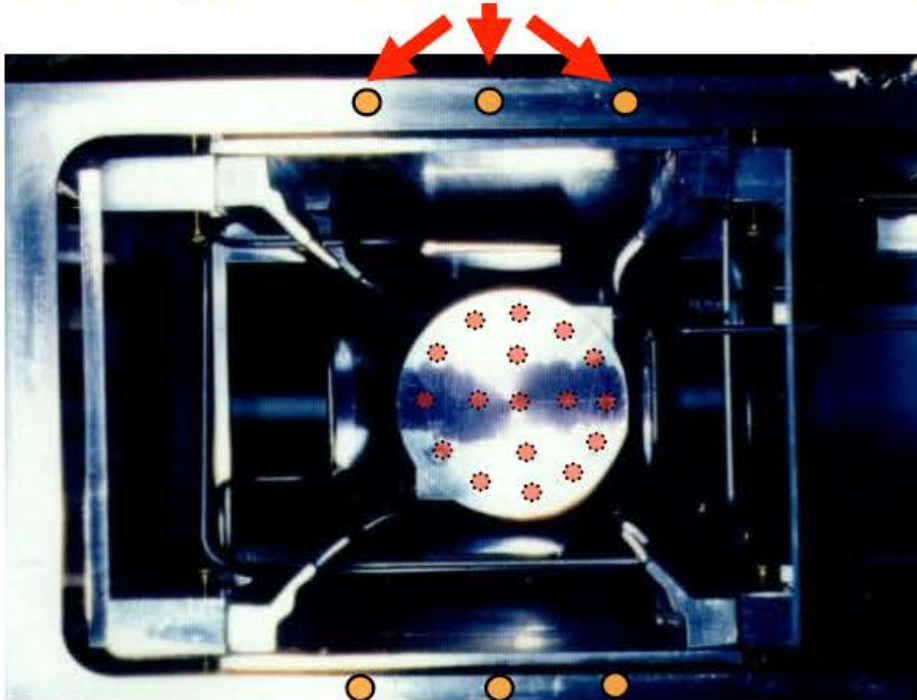

Trolley with matrix of 17 NMR probes

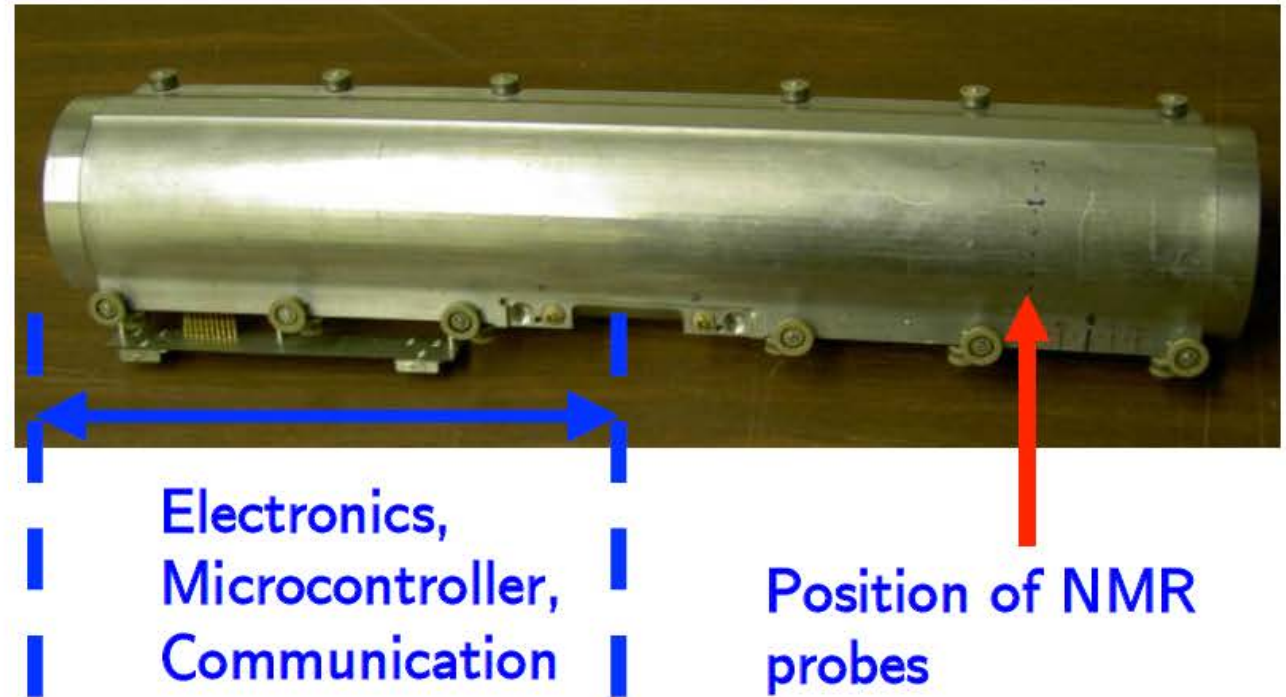

ω_a Systematics

Table 5.2: The largest systematic uncertainties for the final E821 ω_a analysis and proposed upgrade actions and projected future uncertainties for data analyzed using the T method. The relevant Chapters and Sections are given where specific topics are discussed in detail.

Category	E821 [ppb]	E989 Improvement Plans	Goal [ppb]	Chapter & Section
Gain changes	120	Better laser calibration low-energy threshold	20	16.3.1
Pileup	80	Low-energy samples recorded calorimeter segmentation	40	16.3.2
Lost muons CBO	90 70	Better collimation in ring Higher n value (frequency)	20	13.10
E and pitch	50	Better match of beamline to ring Improved tracker Precise storage ring simulations	< 30 30	13.9 4.4
Total	180	Quadrature sum	70	

We will consider the lost muons systematic error in some detail later in this presentation.

ω_p Systematics

Table 5.3: Systematic uncertainties estimated for the magnetic field, ω_p , measurement. The final E821 values are given for reference, and the proposed upgrade actions are projected. Note, several items involve ongoing R&D, while others have dependencies on the uniformity of the final shimmed field, which cannot be known accurately at this time. The relevant Chapters and Sections are given where specific topics are discussed in detail.

Category	E821 [ppb]	Main E989 Improvement Plans	Goal [ppb]	Chapter
Absolute field calibration	50	Special 1.45 T calibration magnet with thermal enclosure; additional probes; better electronics	35	15.4.1
Trolley probe calibrations	90	Plunging probes that can cross calibrate off-central probes; better position accuracy by physical stops and/or optical survey; more frequent calibrations	30	15.4.1
Trolley measurements of B_0	50	Reduced position uncertainty by factor of 2; improved rail irregularities; stabilized magnet field during measurements*	30	15.3.1
Fixed probe interpolation	70	Better temperature stability of the magnet; more frequent trolley runs	30	15.3
Muon distribution	30	Additional probes at larger radii; improved field uniformity; improved muon tracking	10	15.3
Time-dependent external magnetic fields	–	Direct measurement of external fields; simulations of impact; active feedback	5	15.6
Others †	100	Improved trolley power supply; trolley probes extended to larger radii; reduced temperature effects on trolley; measure kicker field transients	30	15.7
Total systematic error on ω_p	170		70	15

In the following eight or nine slides, I will talk about some of my personal contributions:

- field calculation for quads*
- end-to-end simulations*
- application of simulation results to muon loss systematics*

Muon g-2 Storage Ring High Voltage Quadrupoles

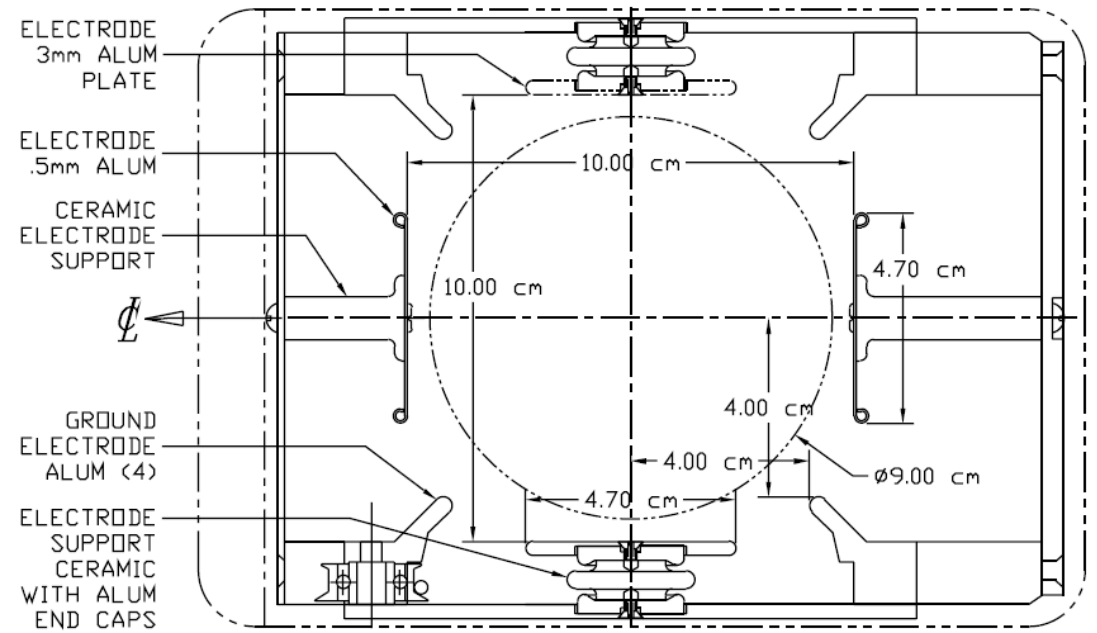
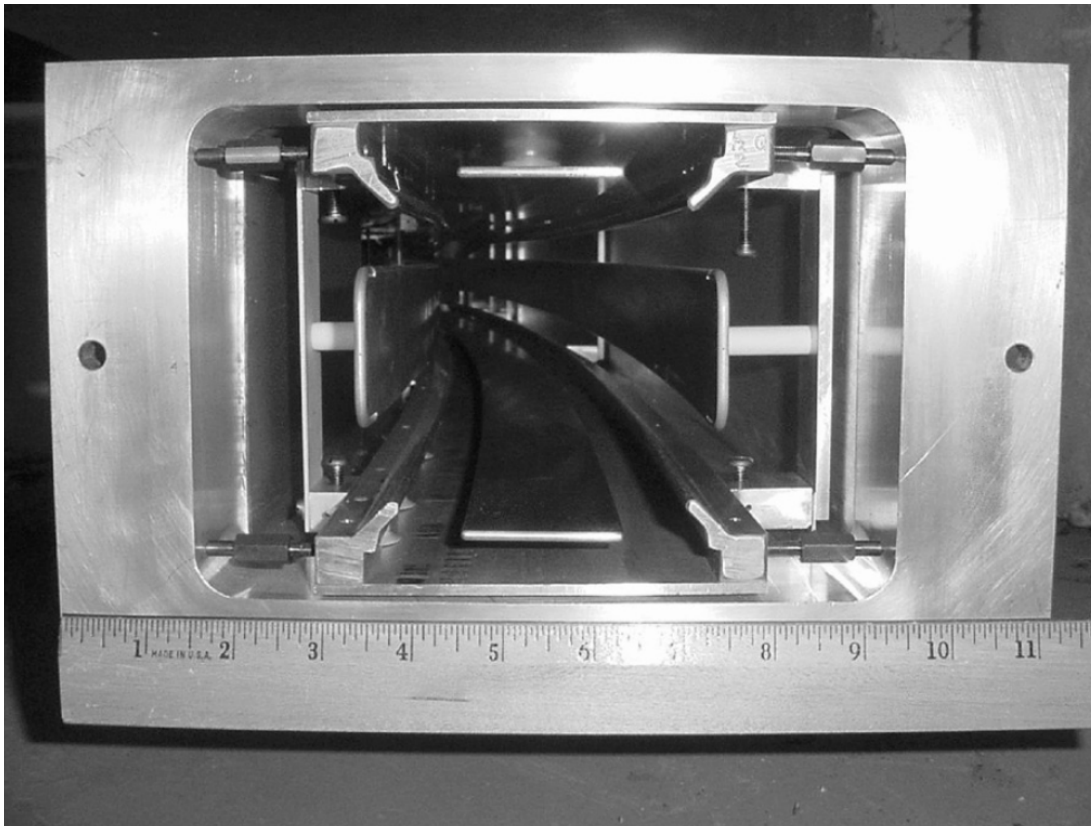

ELECTRODE AND SUPPORT FRAME - END VIEW

Conformal Mapping Methods

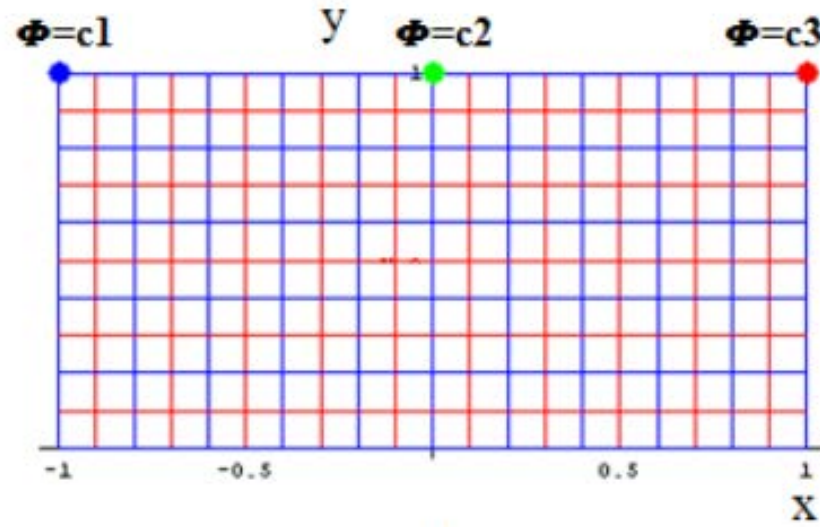

a. z plane

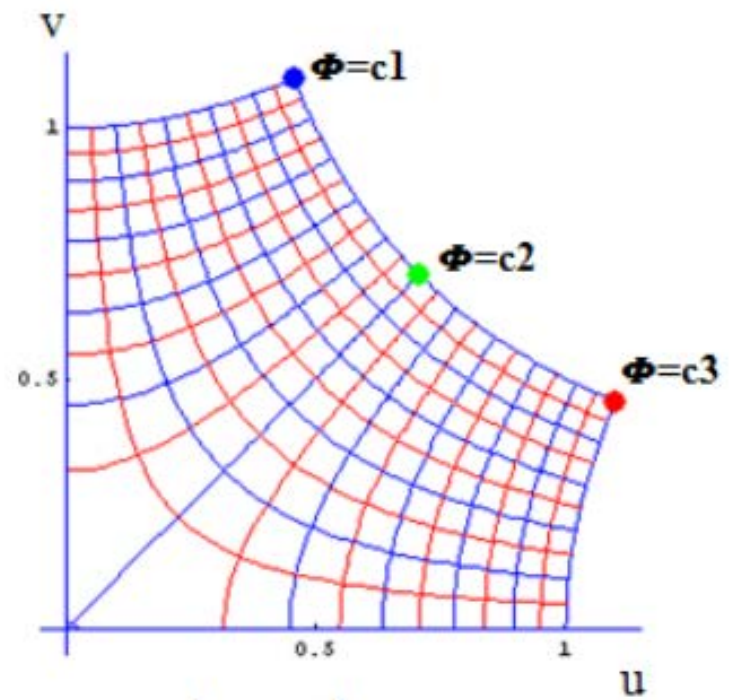

b. w plane

$$f'(z) = c \operatorname{cn}(z|m) \operatorname{dn}(z|m) \prod_{j=1}^n (\operatorname{sn}(z|m) - \operatorname{sn}(x_j + iy_j|m))^{\alpha_j - 1}$$

Advantages of conformal mappings for field calculations:

- Fully Maxwellian
- Rapid recalculations with voltage asymmetries (e.g. for RF scraping)

Multipole Expansion of the Quadrupole Potential

Field dominated by quadrupole moment

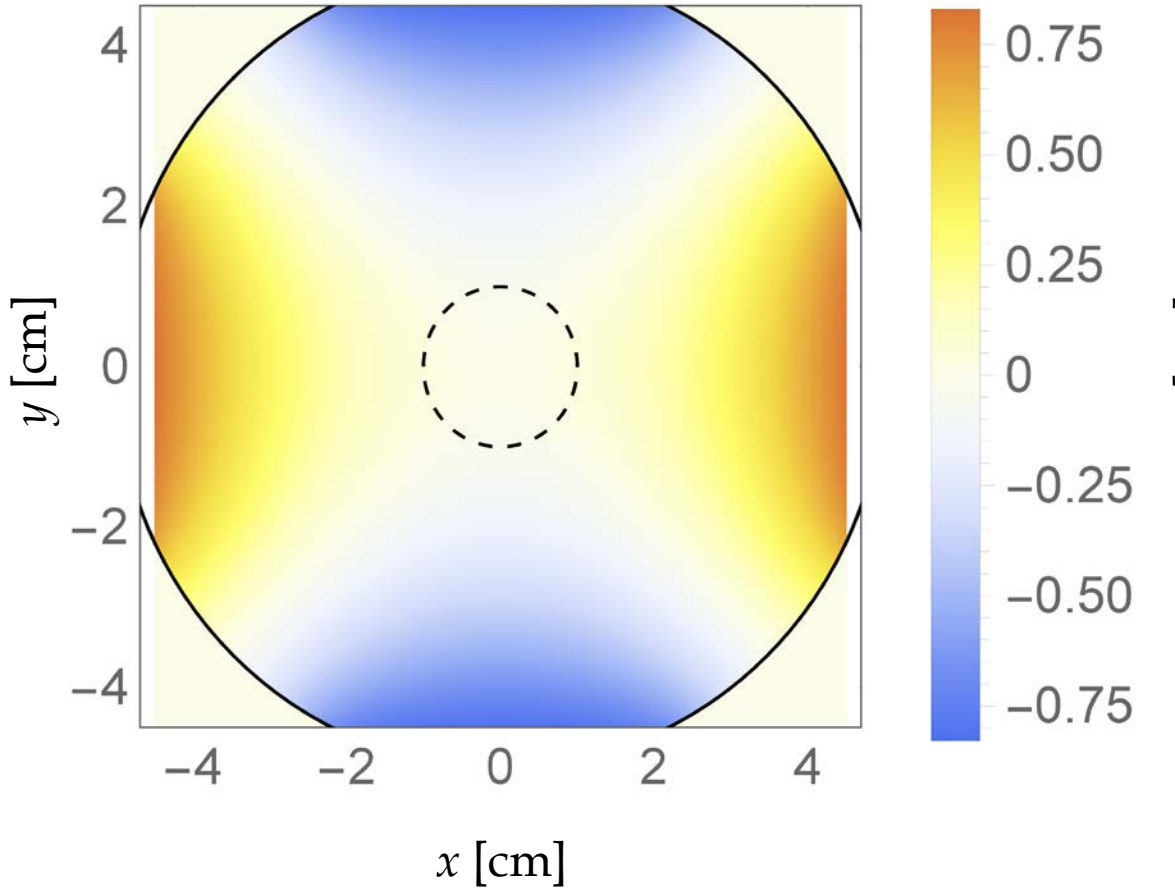

Higher order multipoles after quadrupole subtraction

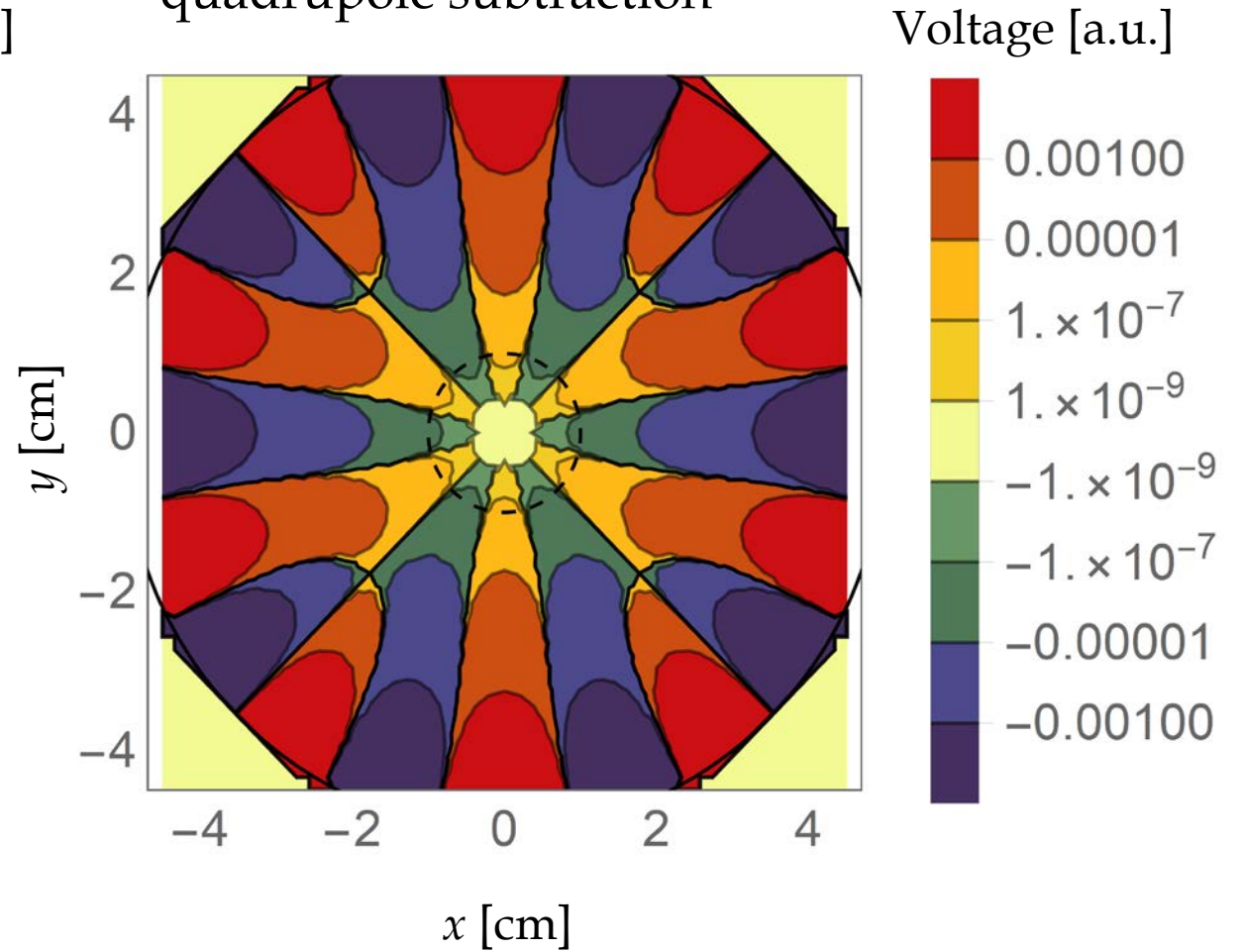

Beamlines of the Muon Campus



(a)

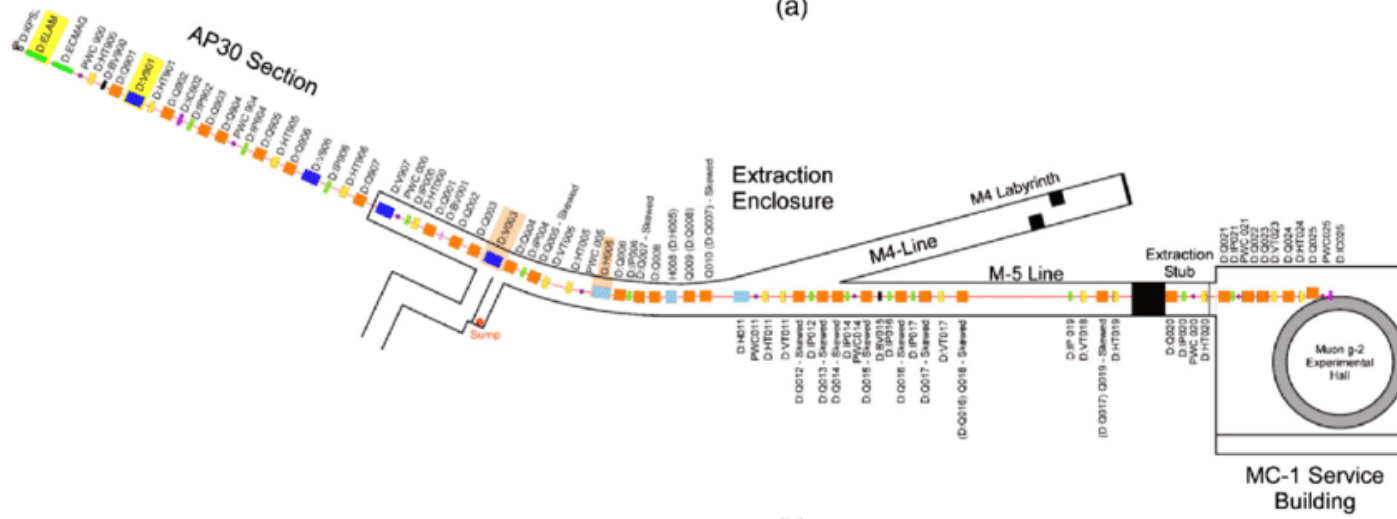

(b)

Need to understand potential sources of early-to-late beam-related systematics.

Muon g-2 Target Station

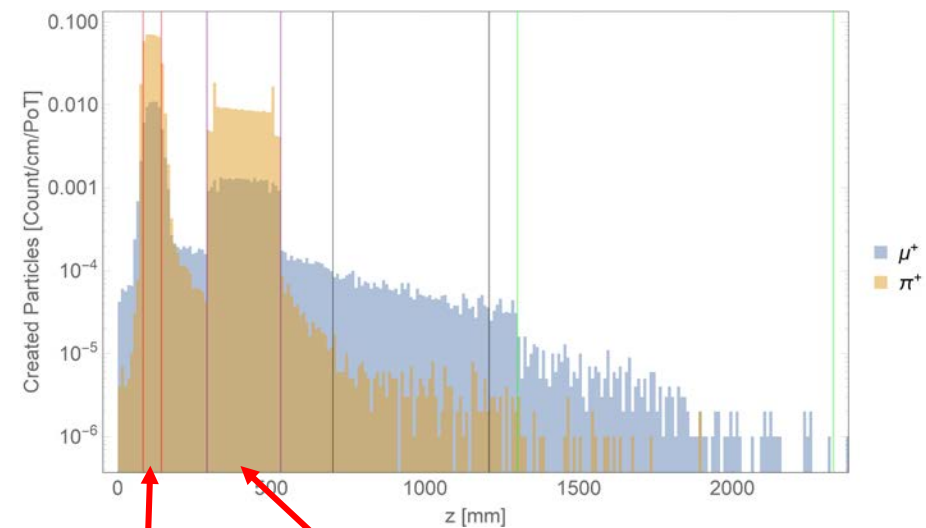
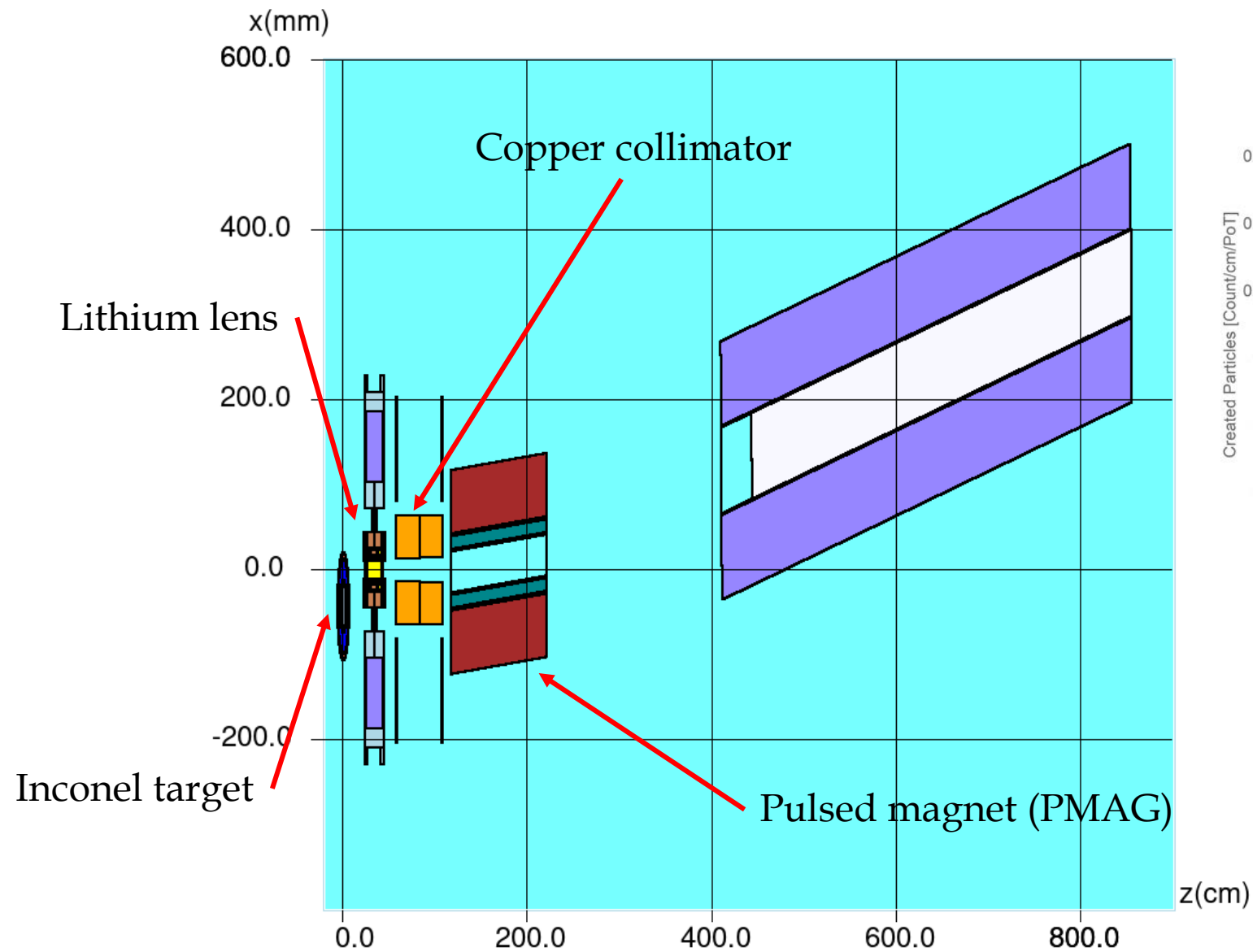

Simulations Using High Performance Computing Systems



2×10^{13} protons
on target

HPC systems:

- NERSC
 - Edison (2013–2019):
2.57 PFLOPS
 - Cori (2015–):
30 PFLOPS
- Open Science Grid
 - Up to 10000 cores
at a time
- FermiGrid

Simulation tools:

- gm2ringsim (Geant4)
- COSY INFINITY
- BMAD
- MARS
- G4Beamline (Geant4)

Dependence of Initial Phase on Muon Creation Location

Simulation results, preliminary

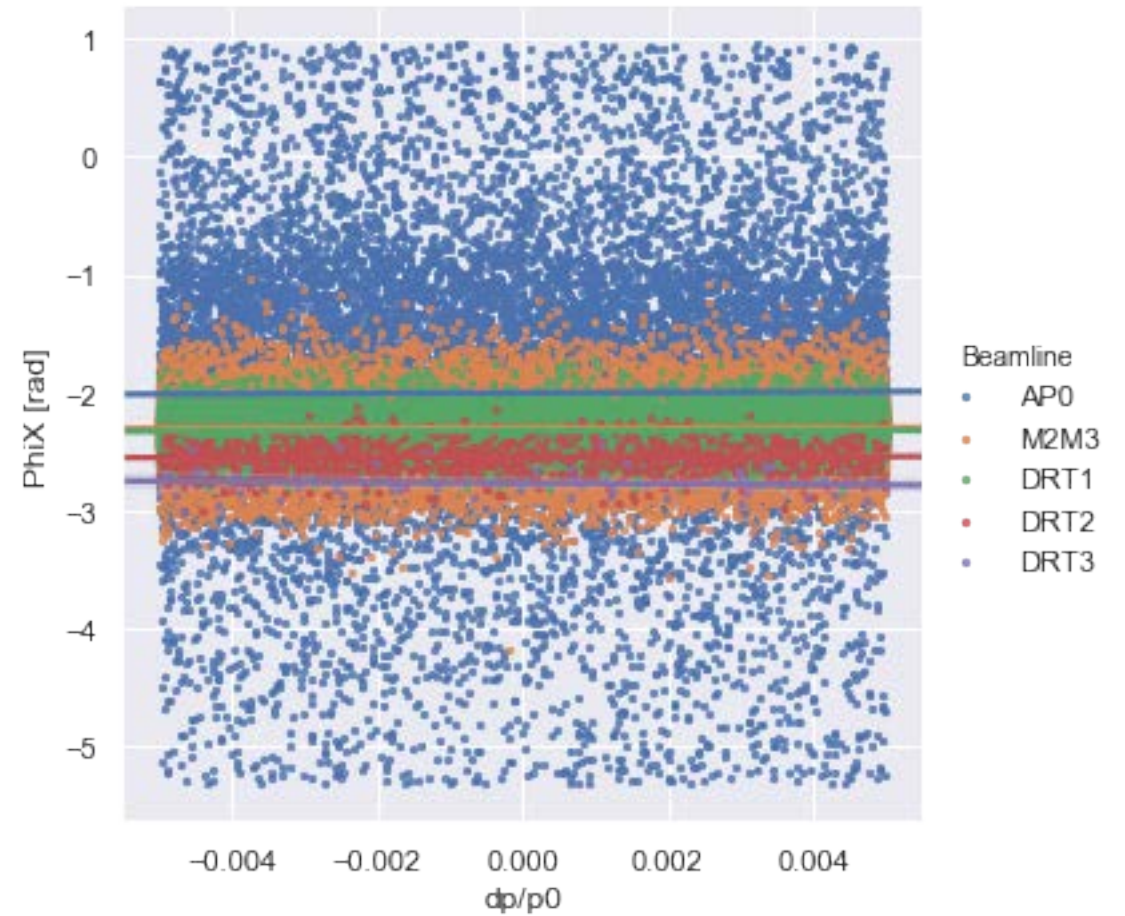
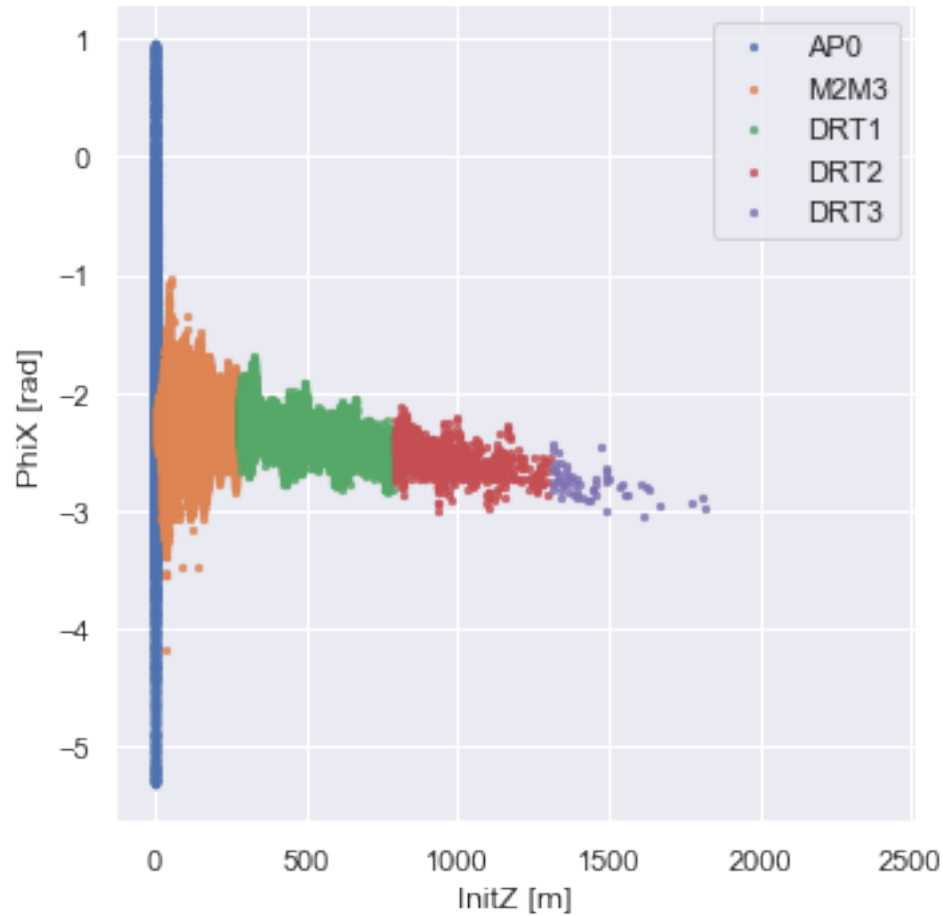

$InitZ$: muon creation location. Φ_{iX} : muon spin phase at entrance into the ring. dp/p_0 : momentum deviation.

All data within $\left| \frac{dp}{dp_0} \right| < 0.5\%$, i.e. 3σ acceptance of the storage ring.

Dependence of Relative Initial Phase on Momentum

Preliminary. Experimental data: Hannah Binney.

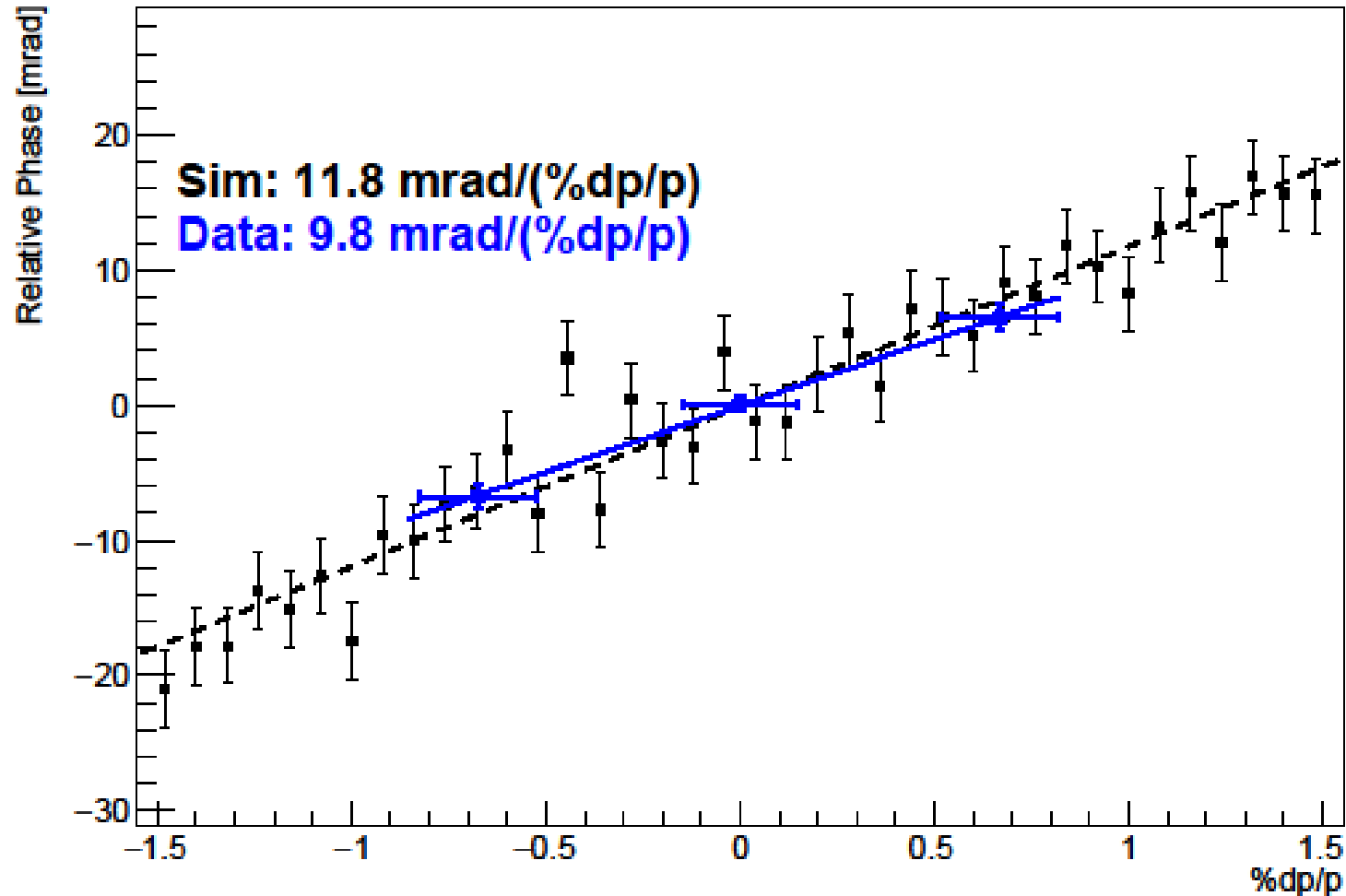

A real momentum dependence of the initial phase develops because of magnetic dipoles in the Delivery Ring.

Experimental data: based on runs with muon storage with higher or lower momenta.

Momentum-Dependent Muon Losses

Simulation results, preliminary (Mike Syphers)

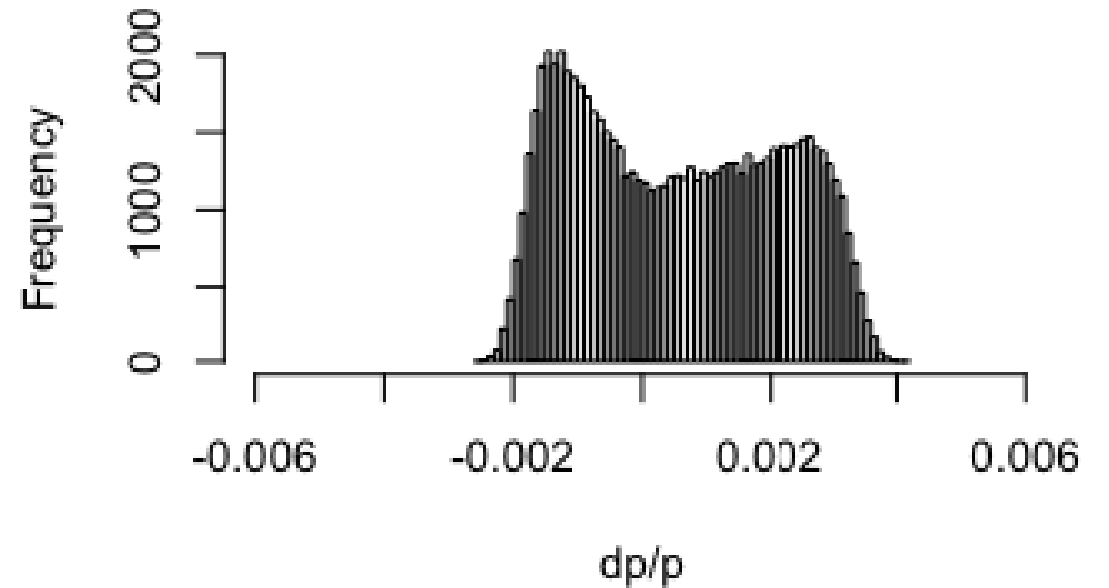
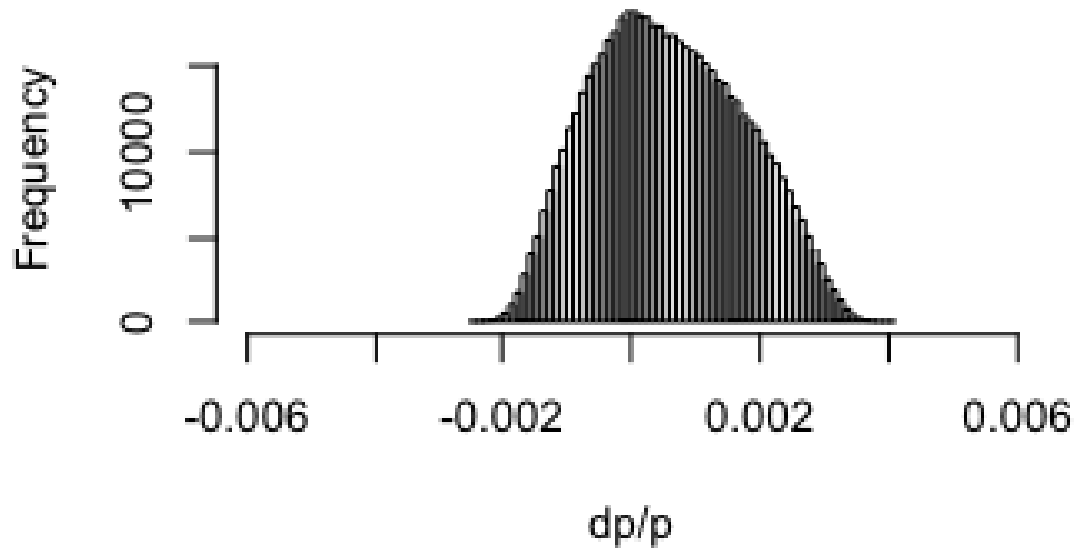

Work is still in progress, but we expect a 10-20 ppb error due to muon losses. Far below the overall 70 ppb systematic error on the spin precession.

Meeting the TDR goal of 20 ppb.

Projection of Data Acquisition as a Multiple of BNL Data

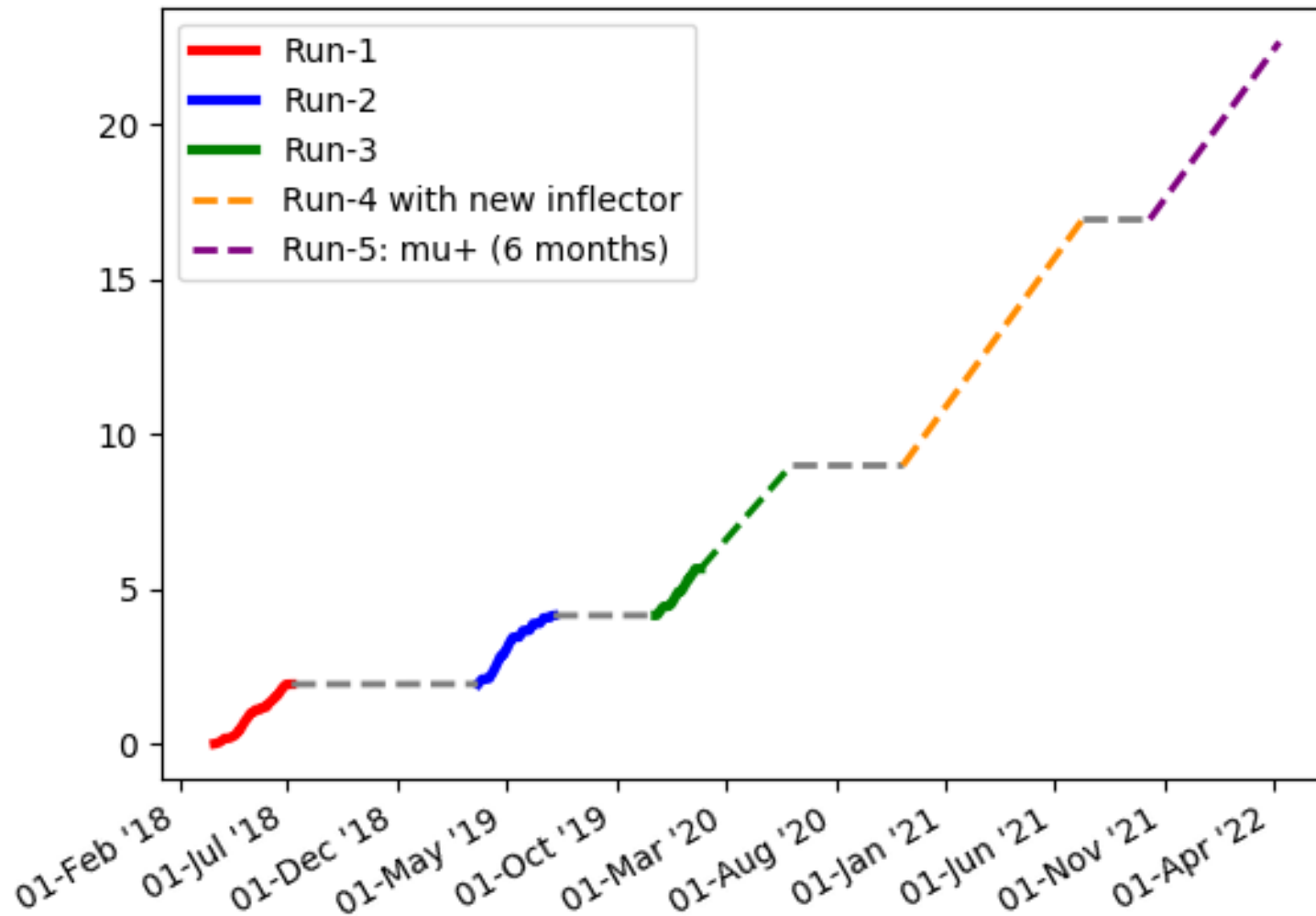

Currently:
~5xBNL physics
quality data

Future EDM or μ^- anomalous MDM Possibilities

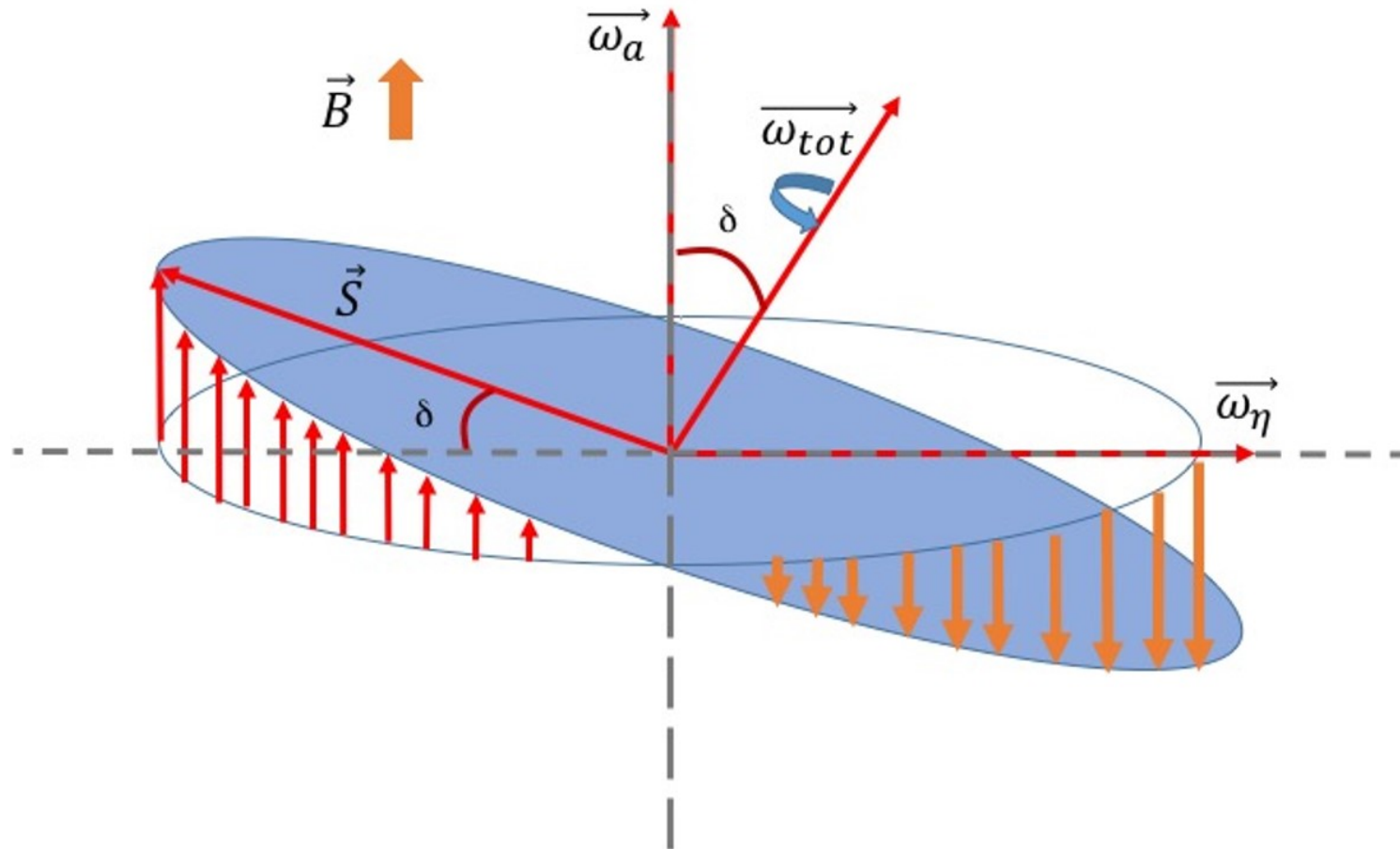

- Currently measuring μ^+ anomalous MDM
- Measure μ^+ EDM using vertical phase asymmetry detection in calorimeters
- Measure μ^- by reconfiguring the beamlines and storage ring (switching electric field direction)
 - No other proposed experiment can do μ^- (JPARC μ^+ only)

- The experiment is running well and has entered Run-3.
- The analysis is coming along, and we are expecting to publish first results this year.
- We have developed sophisticated modeling tools and data-driven approaches to quantify systematics, e.g. the muon loss phase.



U.S. DEPARTMENT OF
ENERGY

Office of
Science

- **This material is based upon work supported by the U.S. Department of Energy, Office of Science, under Contract No. DE-FG02-08ER41546 and Contract No. DE-SC0018636.**
- **This document was prepared by the Muon g-2 collaboration using the resources of the Fermi National Accelerator Laboratory (Fermilab), a U.S. Department of Energy, Office of Science, HEP User Facility. Fermilab is managed by Fermi Research Alliance, LLC (FRA), acting under Contract No. DE-AC02-07CH11359.**
- **This research used resources of the National Energy Research Scientific Computing Center (NERSC), a U.S. Department of Energy Office of Science User Facility operated under Contract No. DE-AC02-05CH11231.**
- **This research was done using resources provided by the Open Science Grid, which is supported by the National Science Foundation award 1148698, and the U.S. Department of Energy's Office of Science.**

Muon g-2 Inflector

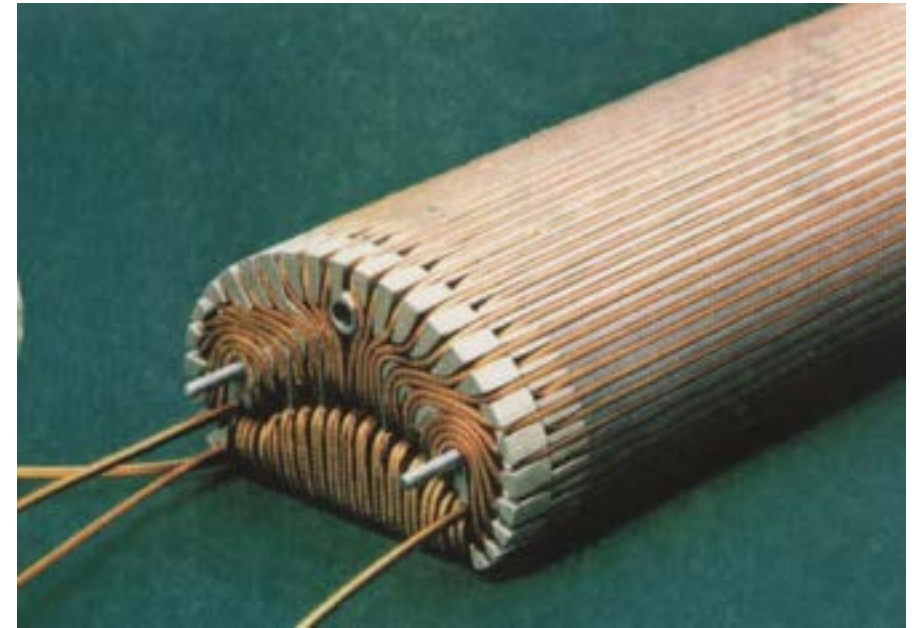
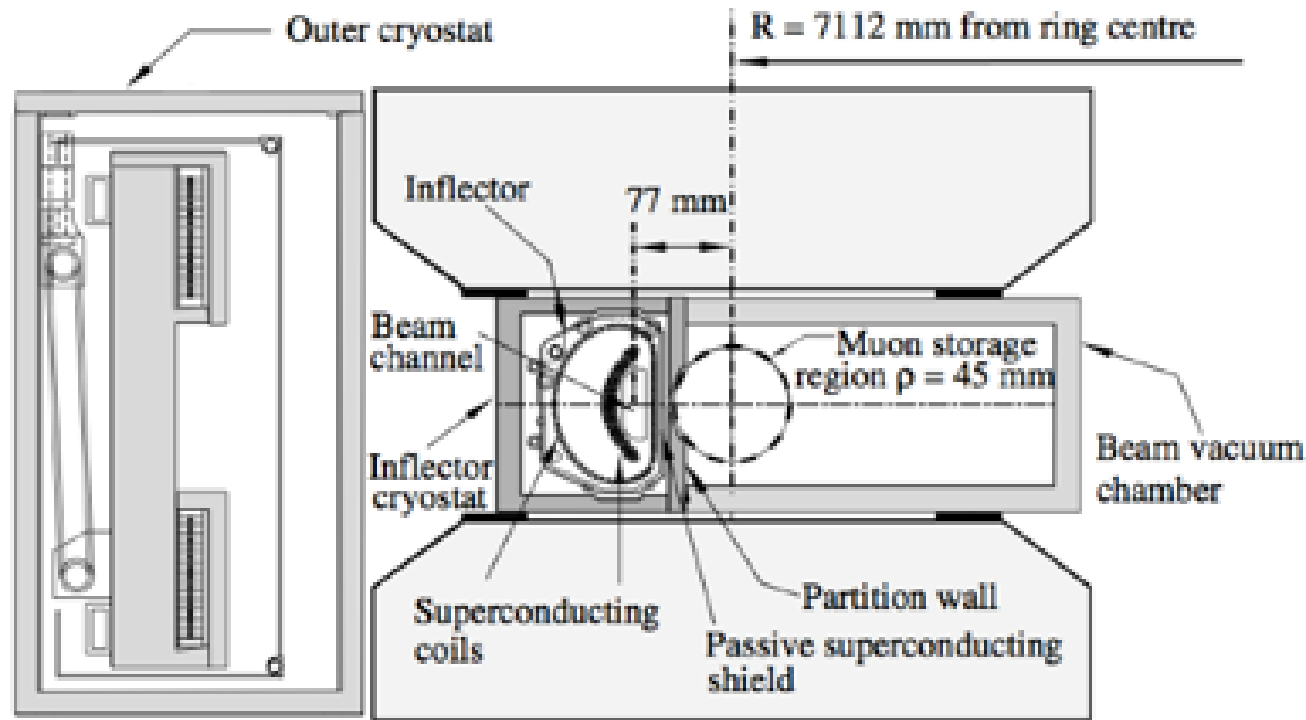

- 1.45 T bucking field to cancel main field
- Can't perturb main field by more than ~ 1 ppm
- Interface optics of storage ring and the M5 beamline

Fitting Function Example: 20 Point

$$N = N_0 \Lambda N_{cbo} N_{2cbo} N_{vw} e^{-t/\tau} (1 - A A_{cbo} \cos(\omega_a t + \phi \phi_{cbo}))$$

$$N_{cbo} = 1 - A_{1cbo} e^{-\frac{t}{\tau_{cbo}}} \cos(\omega_{cbo} t + \phi_{1cbo})$$

$$N_{2cbo} = 1 - A_{2cbo} e^{-\frac{2t}{\tau_{cbo}}} \cos(2\omega_{cbo} t + \phi_{2cbo})$$

$$N_{vw} = 1 - A_{vw} e^{-\frac{t}{\tau_{vw}}} \cos(\omega_{vw} t + \phi_{vw})$$

$$A_{cbo} = 1 - A_{Acbo} e^{-\frac{t}{\tau_{cbo}}} \cos(\omega_{cbo} t + \phi_{Acbo})$$

$$\phi_{cbo} = 1 - A_{\phi_{cbo}} e^{-\frac{t}{\tau_{cbo}}} \cos(\omega_{cbo} t + \phi_{\phi_{cbo}})$$

$$\omega_{cbo} = \omega_0 (1 + 2.875 e^{-\frac{t}{76}/\omega_0} + 5.47 e^{-\frac{t}{8.85}/\omega_0})$$

$$\Lambda = 1 - K_{loss} \int L(t') e^{t'/64.4} dt$$

$$\chi^2 = \sum_{i=1}^{ndf} \left[\frac{N_{bin} - N_{fit}}{\sigma(N_{bin})} \right]^2$$

Momentum-Dependent Muon Losses

Mike Syphers

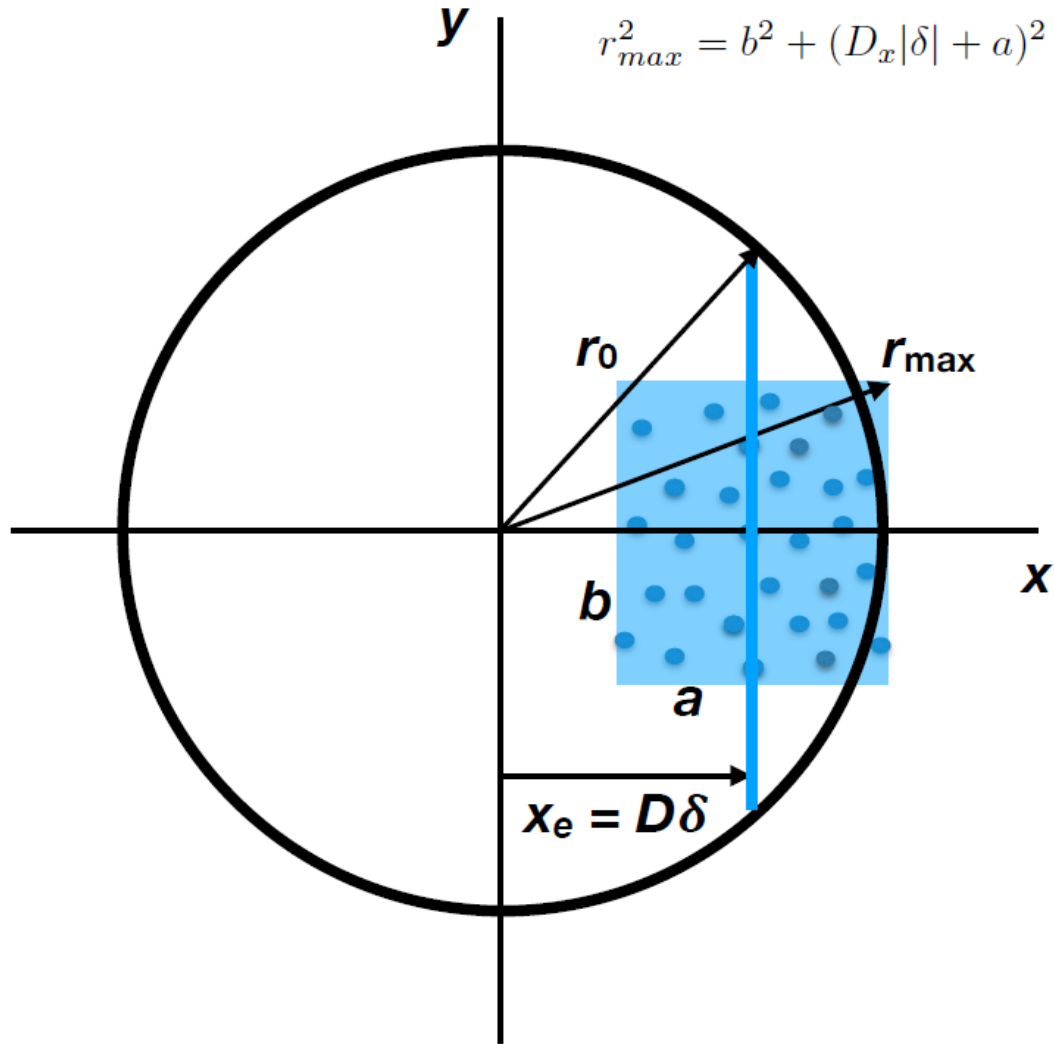

$$\frac{\Delta\omega_a}{\omega_a} = \frac{1}{\omega_a} \frac{d\langle\Phi\rangle}{d\langle dp/p_0\rangle} \frac{d\langle dp/p_0\rangle}{dt}$$

Straw Tracking Detectors

