

Injection and Extraction (+Kickers, Septa)

Frank Tecker, CERN (BE-OP)

based on lectures by Matthew Fraser and M.J. Barnes, W. Bartmann, J. Borburgh, V. Forte, B. Goddard, V. Kain and M. Meddahi

- Introduction: Kickers, septa and normalised phase-space
- Injection methods
 - Single-turn hadron injection
 - Injection errors, filamentation and blow-up
 - Multi-turn hadron injection
 - Charge-exchange H- injection
 - Lepton injection
- Extraction methods
 - Single-turn (fast) extraction
 - Non-resonant and resonant multi-turn (fast) extraction
 - Resonant multi-turn (slow) extraction
- Linking machines

Many THANKS!!

Injection and extraction

- An accelerator has limited dynamic range
- Chain of stages needed to reach high energy
- Periodic re-filling of storage rings, like LHC
- External facilities and experiments:
 - e.g. ISOLDE, HIRADMAT, AWAKE...

Beam transfer (into, out of, and between machines) is necessary.

CERN Accelerator Complex

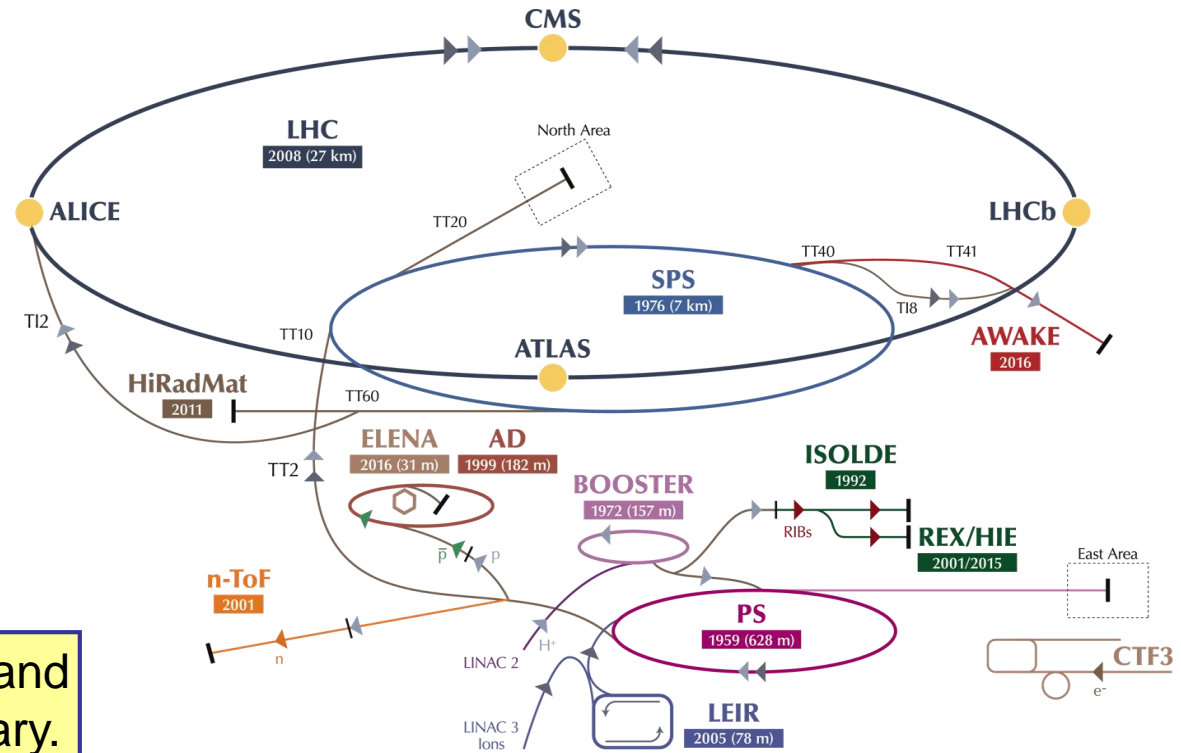

▶ p (protons)
 ▶ ions
 ▶ RIBs (Radioactive Ion Beams)
 ▶ n (neutrons)
 ▶ \bar{p} (antiprotons)
 ▶ e^- (electrons)
 ▶ \leftrightarrow proton/antiproton conversion
 ▶ \leftrightarrow proton/RIB conversion

LHC Large Hadron Collider SPS Super Proton Synchrotron PS Proton Synchrotron AD Antiproton Decelerator CTF3 Clic Test Facility

AWAKE Advanced WAKEfield Experiment ISOLDE Isotope Separator OnLine REX/HIE Radioactive EXperiment/High Intensity and Energy ISOLDE

LEIR Low Energy Ion Ring LINAC LInear ACcelerator n-ToF Neutrons Time Of Flight HiRadMat High-Radiation to Materials

Basics: injection, septum and kicker

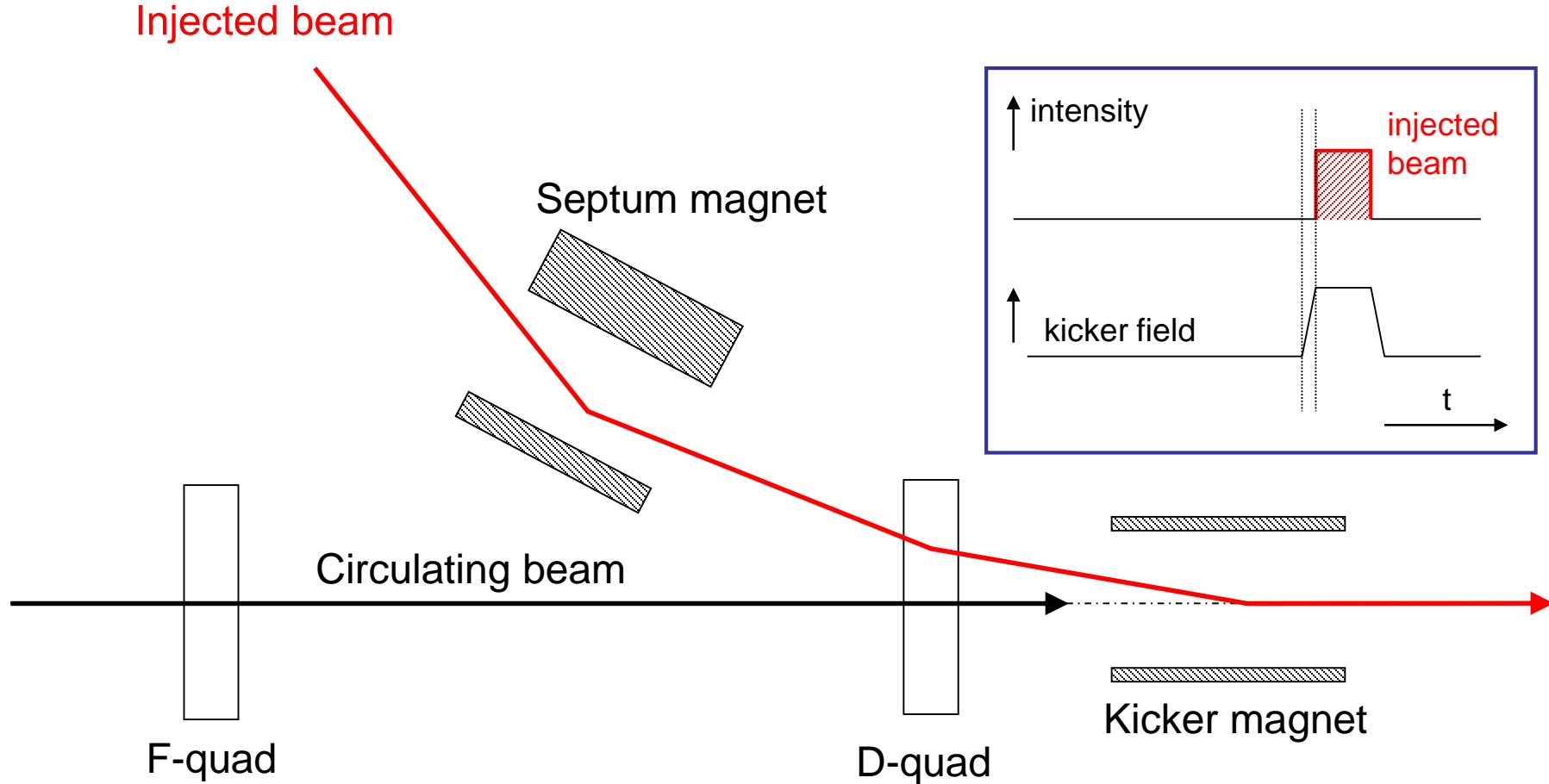

- **Kickers** produce fast pulses, rising their field within the particle-free gap in the circulating beam (**temporal separation**)
- **Septa** compensate for the relatively low kicker strength, and approach closely the circulating beam (**spatial separation**)

Google

- Kicker



- Septum



...so we also call them
“Fast Pulsed Magnets”

Kickers - Magnetic parameters

Pulsed magnet with very fast rise time (<100 ns – few μ s)

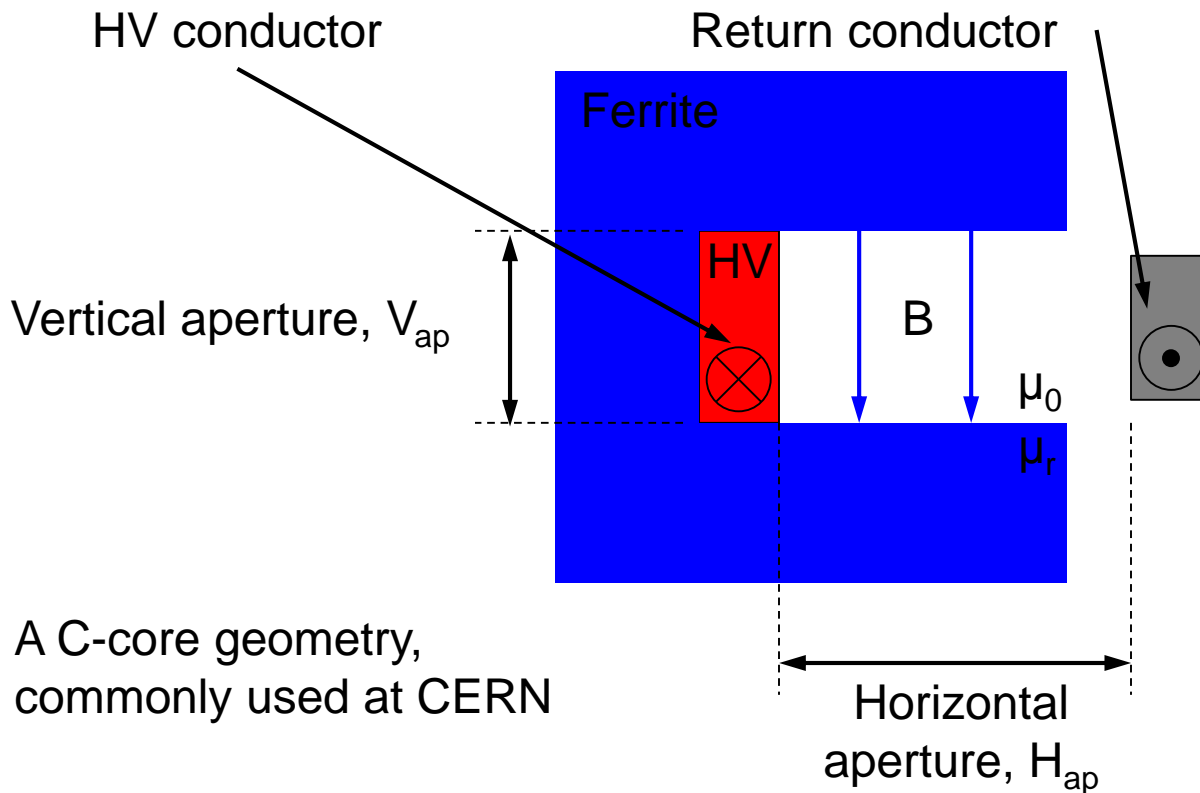

Magnetic field

$$B_y @ m_0 \frac{N \times I}{V_{ap}}$$

Derivation: remember Ampère's Law:

$$\oint_c \vec{B} \cdot d\vec{l} = \mu_0 I_{enc}$$

Magnet inductance
[per unit length]

$$L_{mag/m} @ m_0 \frac{N^2 \times H_{ap}}{V_{ap}}$$

Derivation: remember Faraday's Law:

$$F_B = \dot{V} dt \quad \text{and} \quad V = L dI/dt$$

- Dimensions H_{ap} and V_{ap} specified by beam parameters at kicker location
- Ferrite (permeability $\mu_r \approx 1000$) reinforces magnetic circuit and field uniformity in the gap
- For fast rise-times the inductance must be minimised: typically the number of turns, $N = 1$
- Kickers are often split into several magnet units, powered independently

Magnetic and electrostatic septum

Magnetic

Septum coil: **2 – 20 mm**

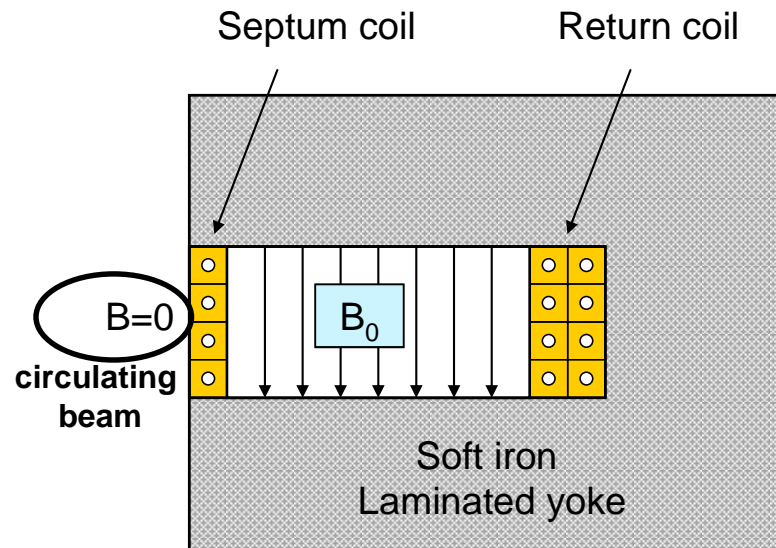

$$B_0 = \mu_0 I / g$$

Typically I 5 - 25 kA

Electrostatic

Thin wire or coil: **~0.1 mm**

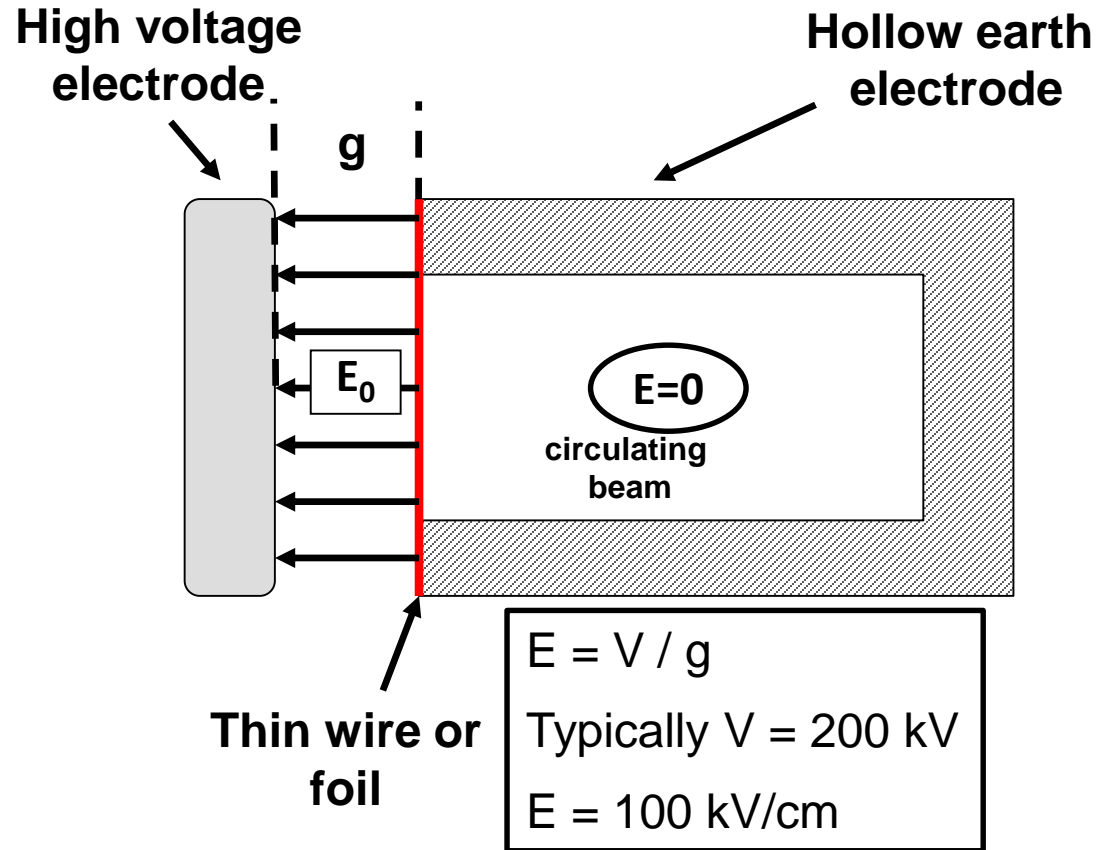

$$E = V / g$$

Typically $V = 200$ kV
 $E = 100$ kV/cm

Single-turn injection – same plane

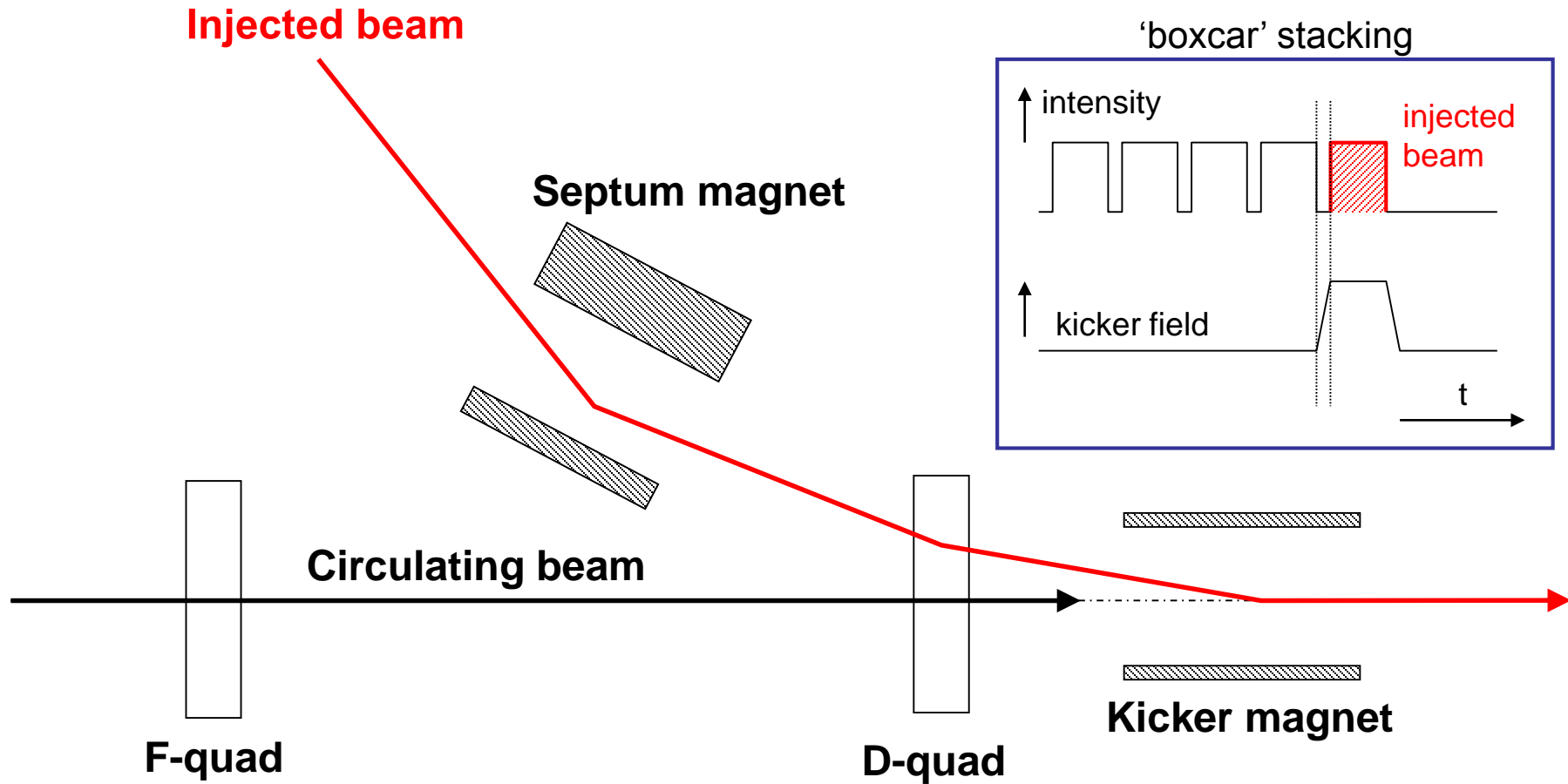

- Septum deflects the beam onto the closed orbit at the centre of the kicker
- Kicker compensates for the remaining angle
- Septum and kicker either side of D quad to minimise kicker strength

Normalised phase space

- Transform real transverse coordinates (x, x', s) to normalised co-ordinates (\bar{X}, \bar{X}', m) where the independent variable becomes the phase advance μ :

$$\begin{bmatrix} \bar{X} \\ \bar{X}' \end{bmatrix} = \mathbf{N} \cdot \begin{bmatrix} x \\ x' \end{bmatrix} = \sqrt{\frac{1}{\beta(s)}} \cdot \begin{bmatrix} 1 & 0 \\ \alpha(s) & \beta(s) \end{bmatrix} \cdot \begin{bmatrix} x \\ x' \end{bmatrix}$$

$$x(s) = \sqrt{\epsilon} \sqrt{b(s)} \cos[m(s) + m_0]$$

$$m(s) = \int_0^s \frac{ds}{b(s)}$$

$$\bar{X}(\mu) = \sqrt{\frac{1}{\beta(s)}} \cdot x = \sqrt{\epsilon} \cos[\mu + \mu_0]$$

$$\bar{X}'(\mu) = \sqrt{\frac{1}{\beta(s)}} \cdot \alpha(s)x + \sqrt{\beta(s)}x' = -\sqrt{\epsilon} \sin[\mu + \mu_0] = \frac{d\bar{X}}{d\mu}$$

Normalised phase space

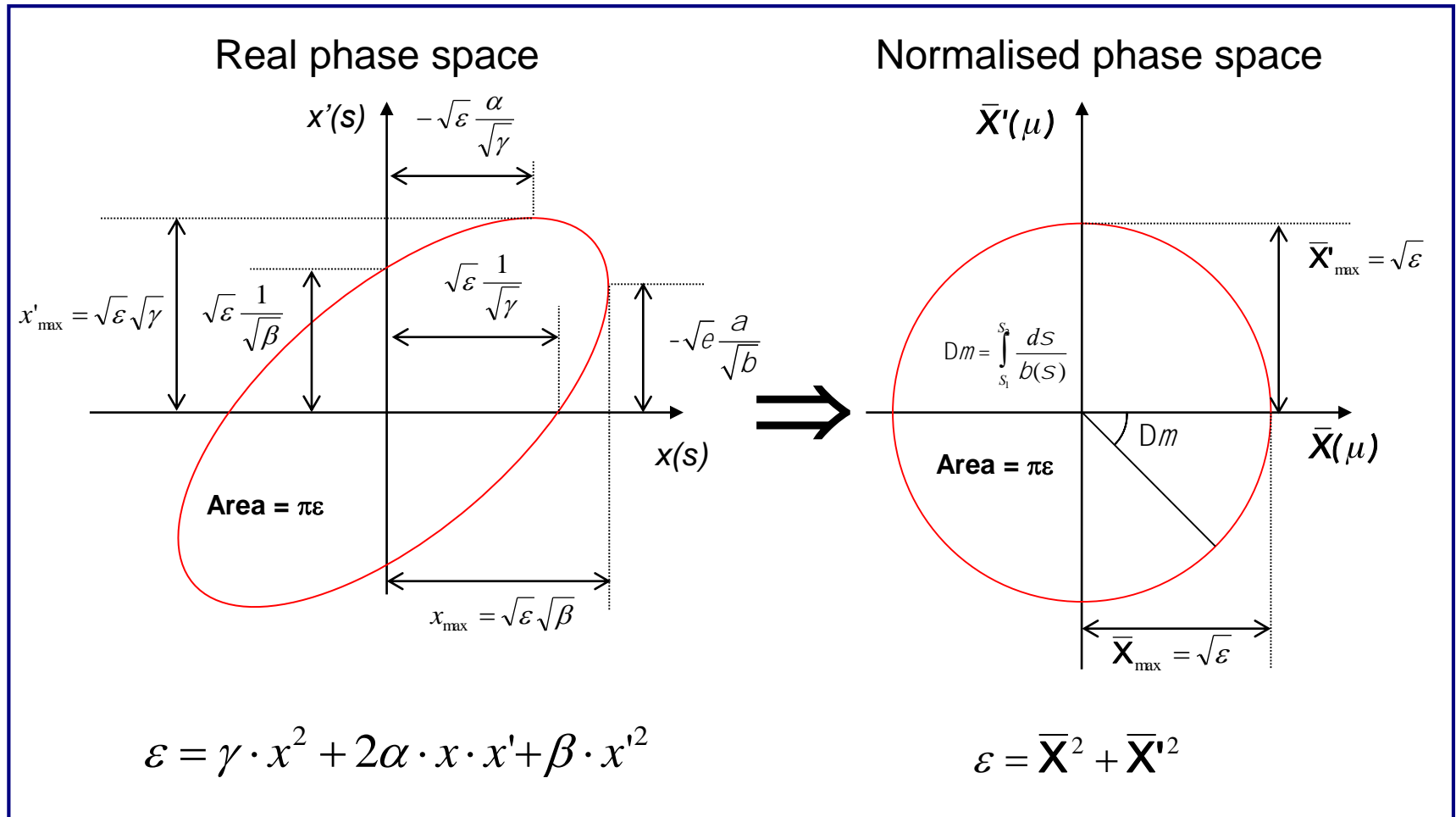

Single-turn injection

Normalised phase space at centre of idealised septum

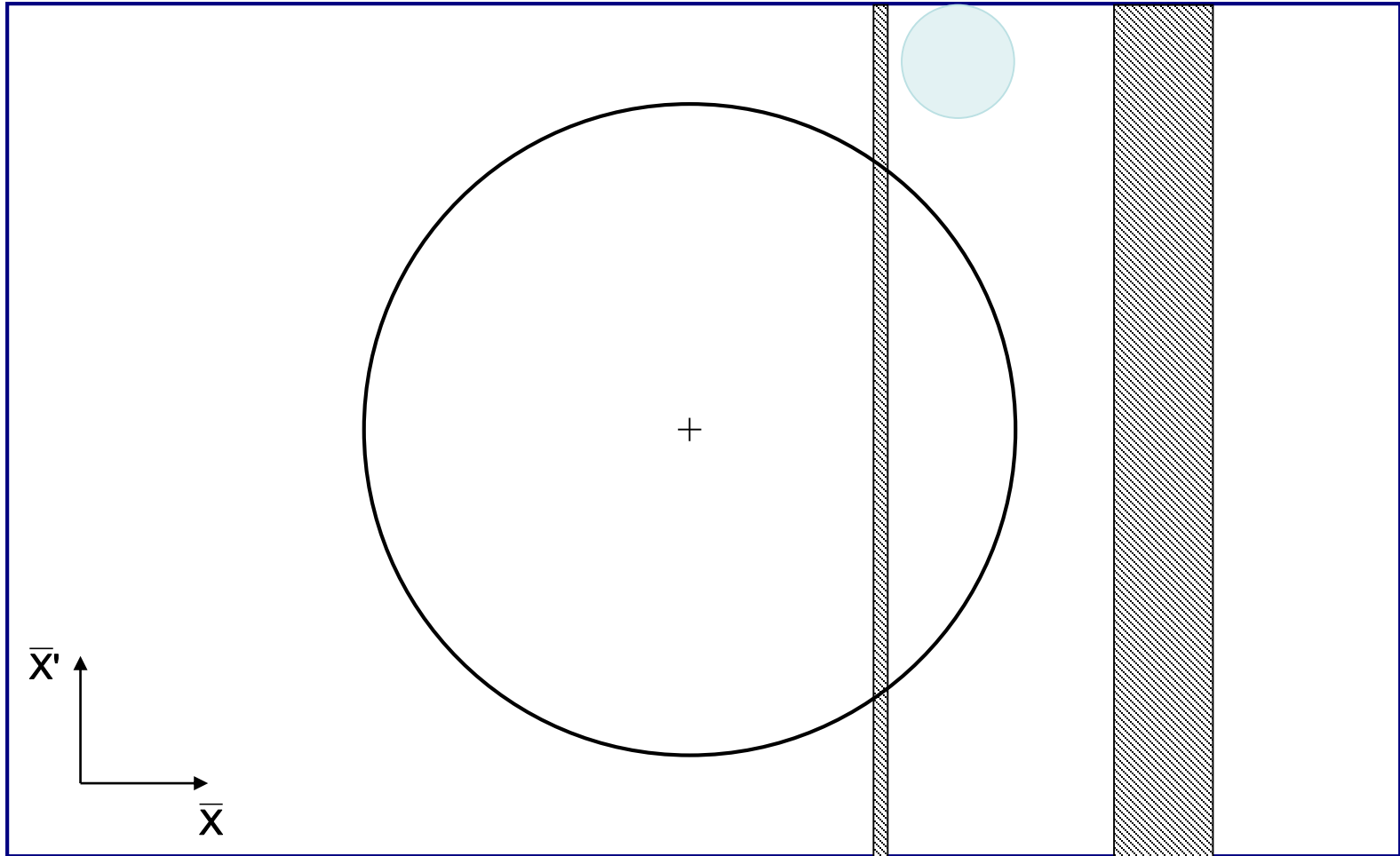

Single-turn injection

Normalised phase space at centre of idealised septum

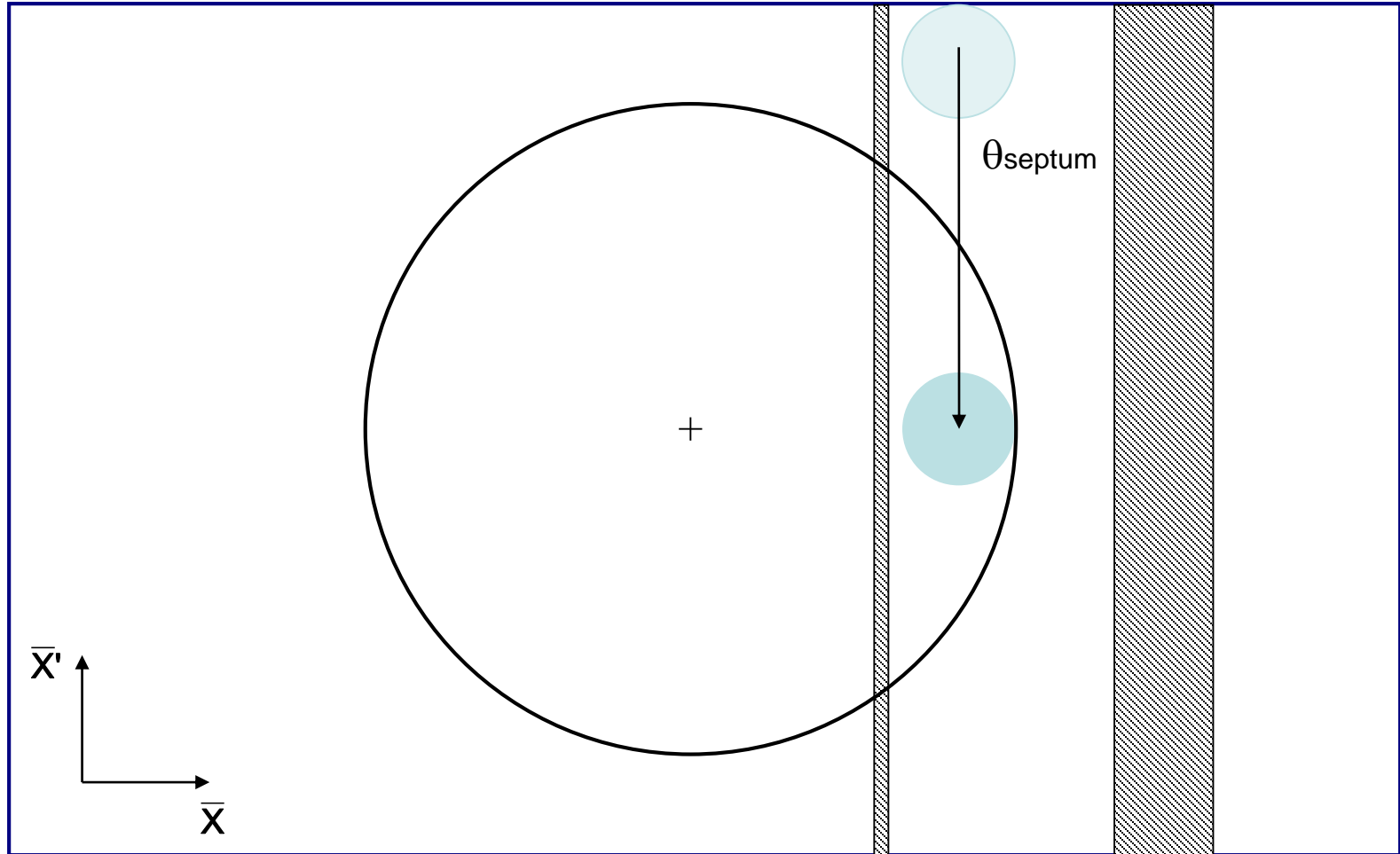

Single-turn injection

$\mu/2$ phase advance to kicker location

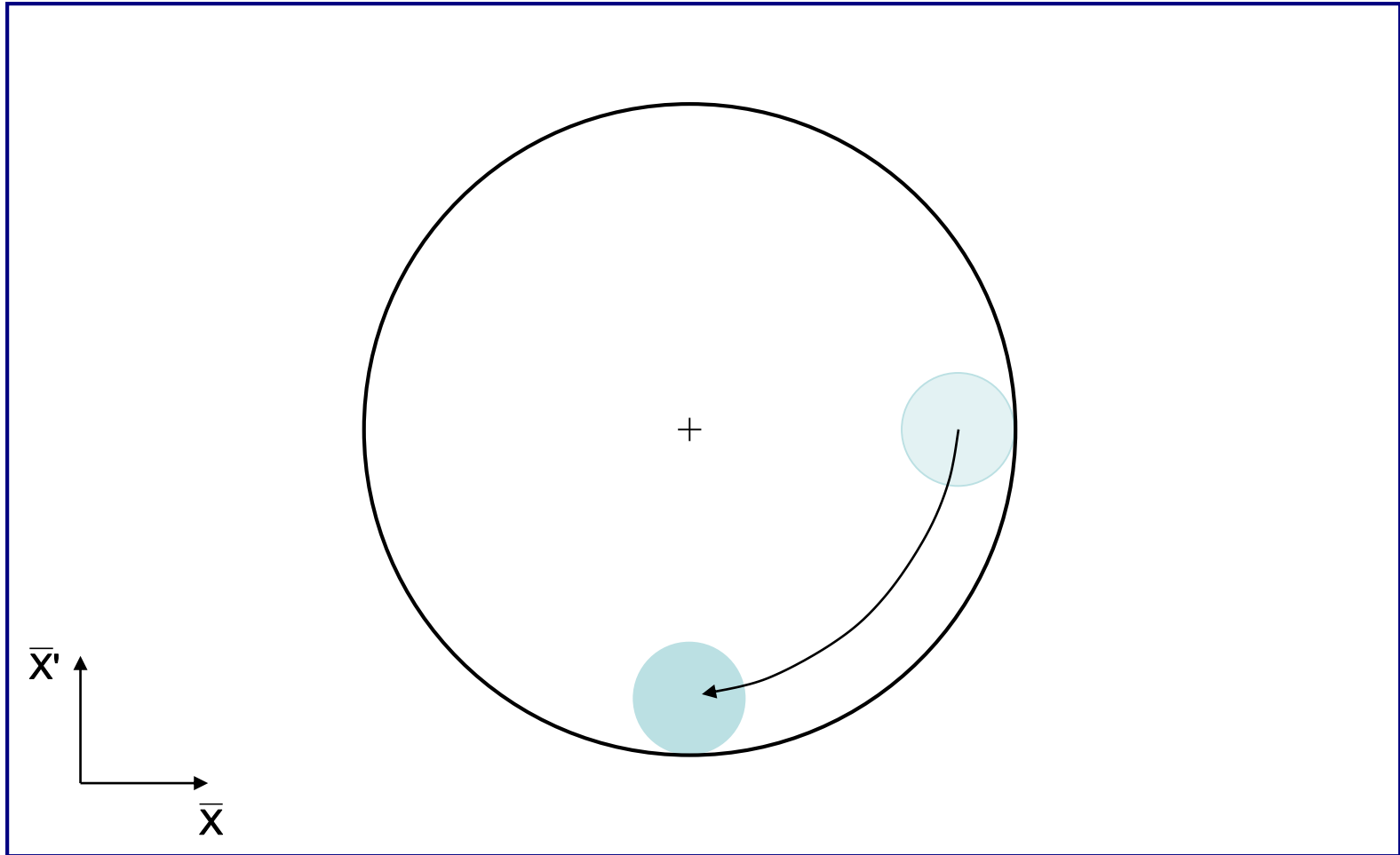

Single-turn injection

Normalised phase space at centre of idealised kicker

Kicker deflection places beam on central orbit:

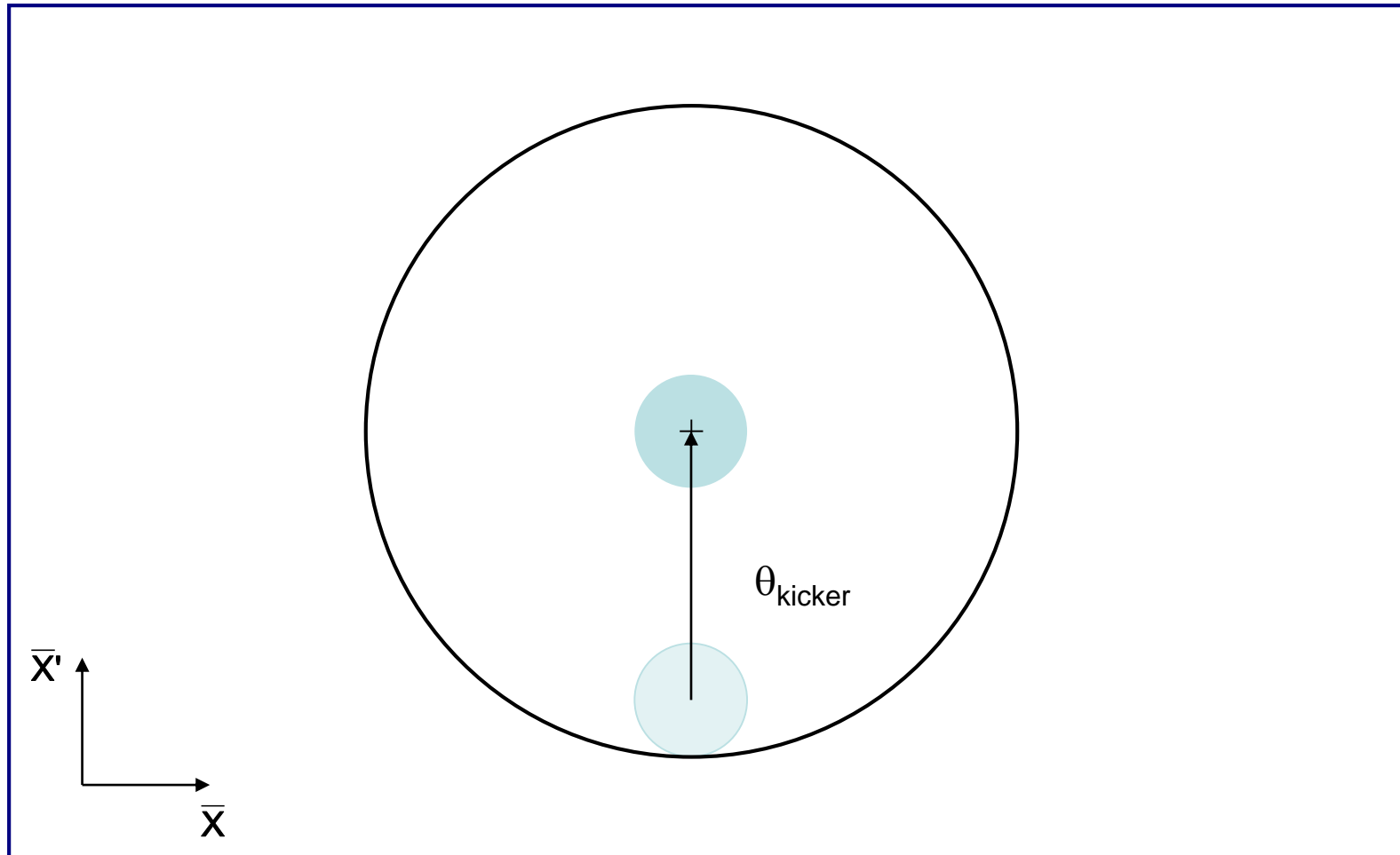

Injection oscillations

For imperfect injection the beam oscillates around the central orbit, e.g. kick error, Δ :

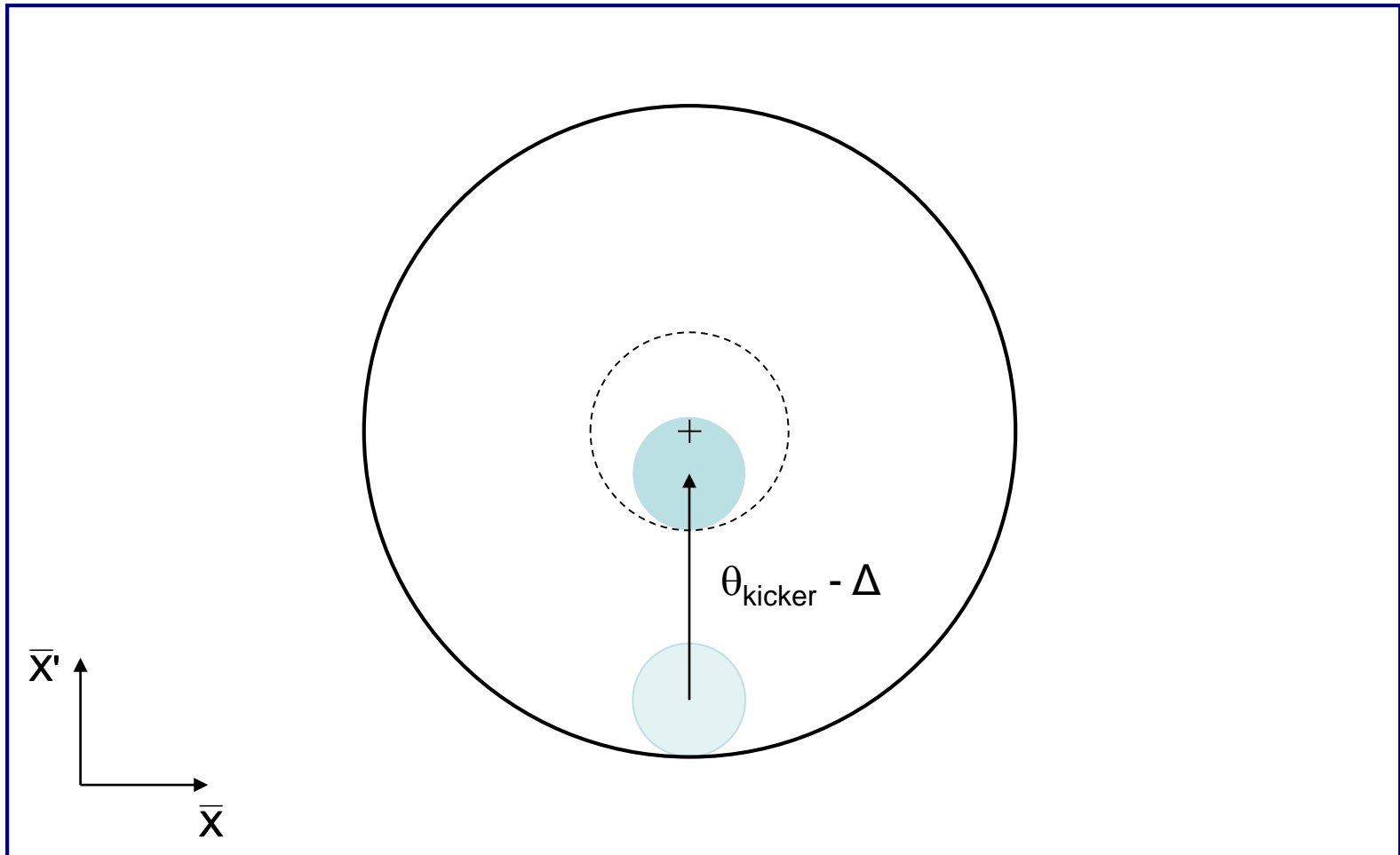

Injection oscillations

For imperfect injection the beam oscillates around the central orbit, e.g. kick error, Δ :

After 1 turn...

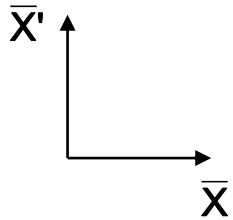
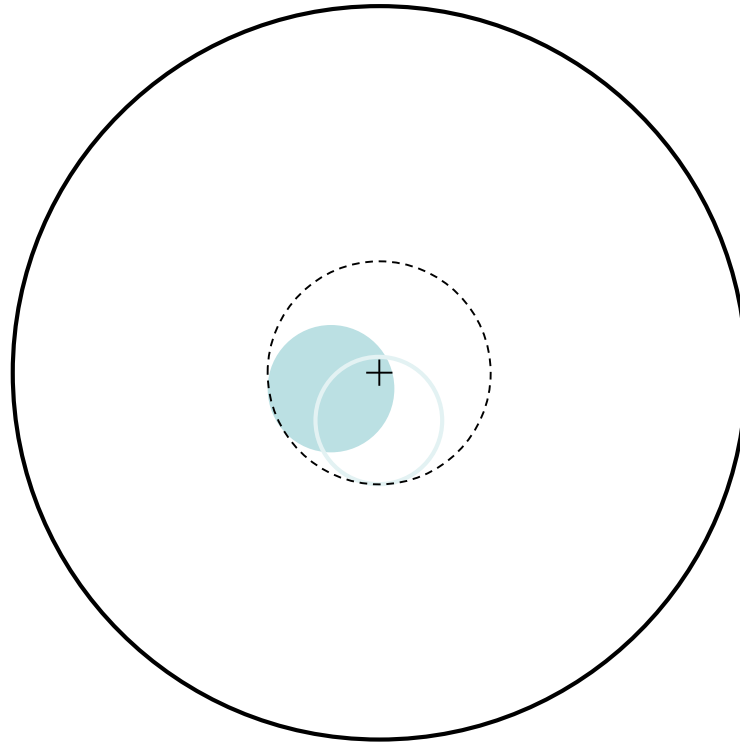

Injection oscillations

For imperfect injection the beam oscillates around the central orbit, e.g. kick error, Δ :

After 2 turns...

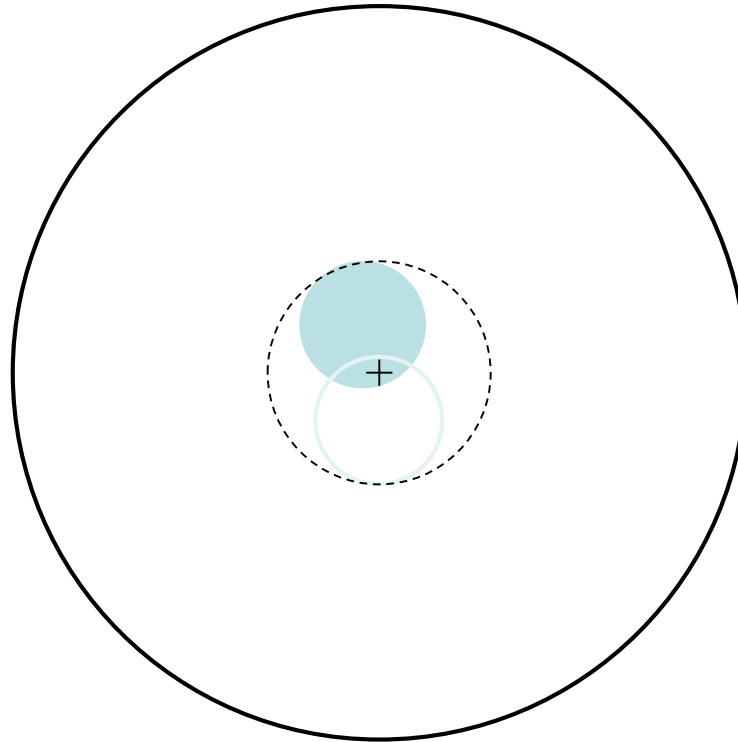

Injection oscillations

For imperfect injection the beam oscillates around the central orbit, e.g. kick error, Δ :

After 3 turns etc...

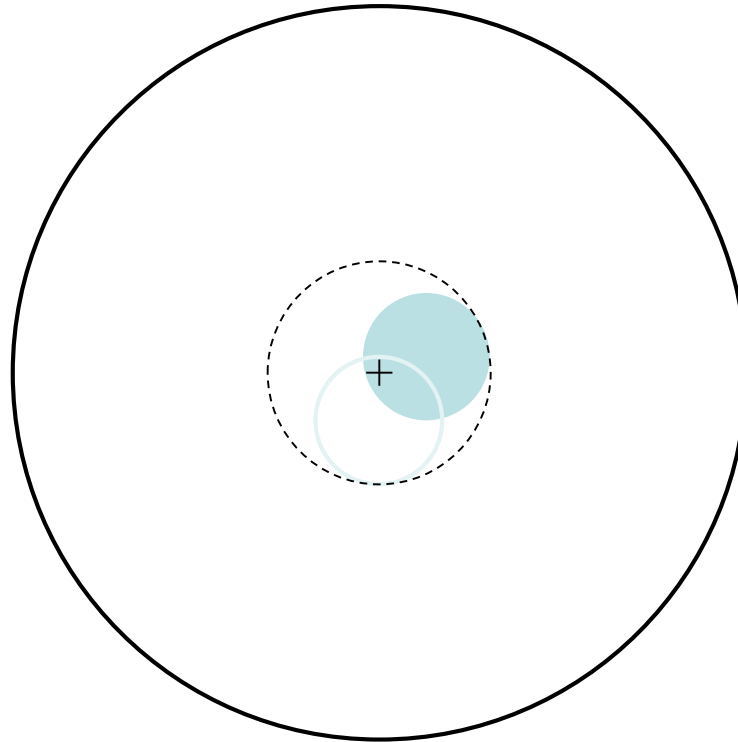

Injection oscillations

- Betatron oscillations with respect to the Closed Orbit:

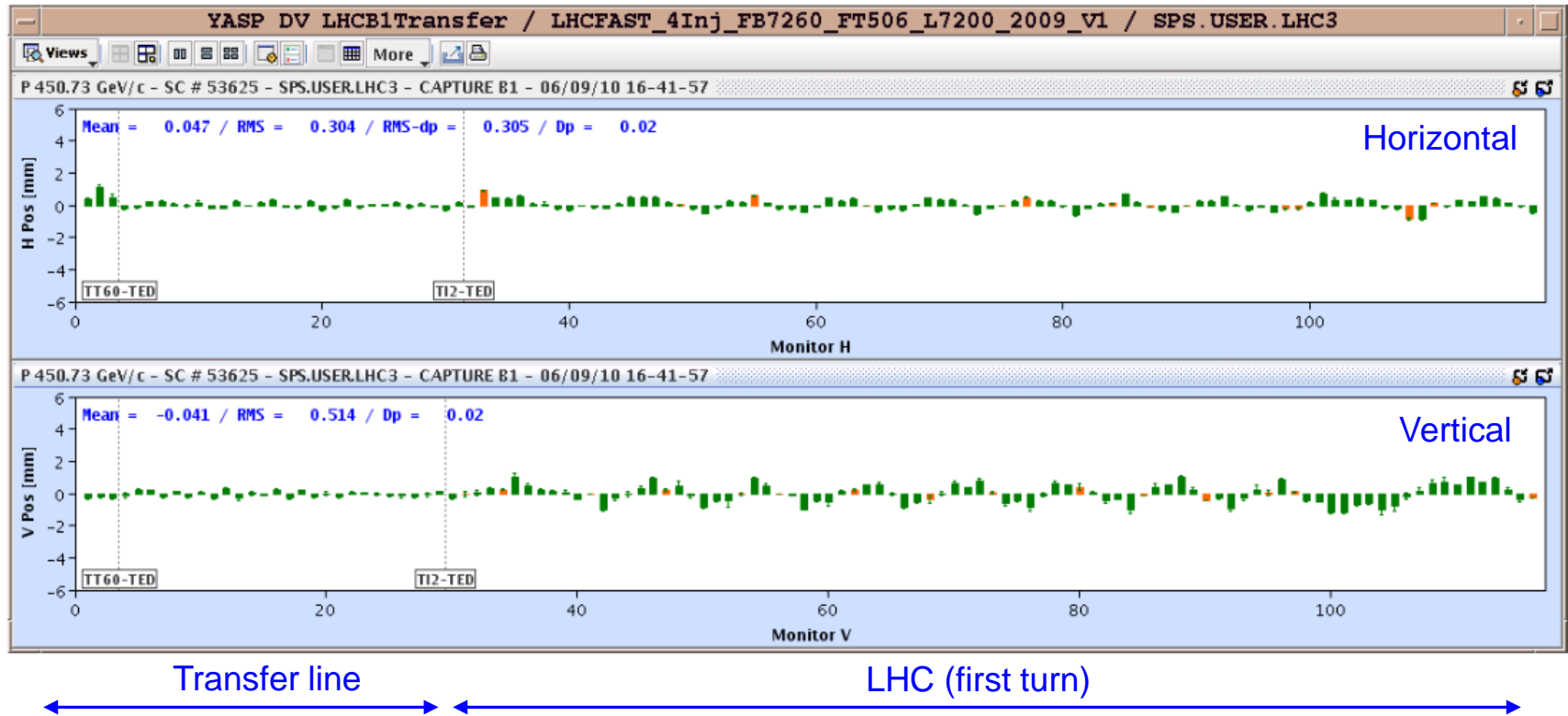

- Angular errors from septa and kicker have different orbit pattern
- Correct the difference between injected beam and closed orbit or 1st and 2nd turn

Filamentation

- Non-linear effects (e.g. higher-order field components) introduce amplitude-dependent effects into particle motion
- Over many turns, a phase-space oscillation is transformed into an emittance increase
- So any residual transverse oscillation will lead to an emittance blow-up through filamentation
 - “Transverse damper” systems are used to damp injection oscillations - bunch position measured by a pick-up, which is linked to a kicker
 - Chromaticity coupled with a non-zero momentum spread at injection can also cause filamentation, often termed *chromatic decoherence*
- See appendix for derivation of the emittance increase

Filamentation

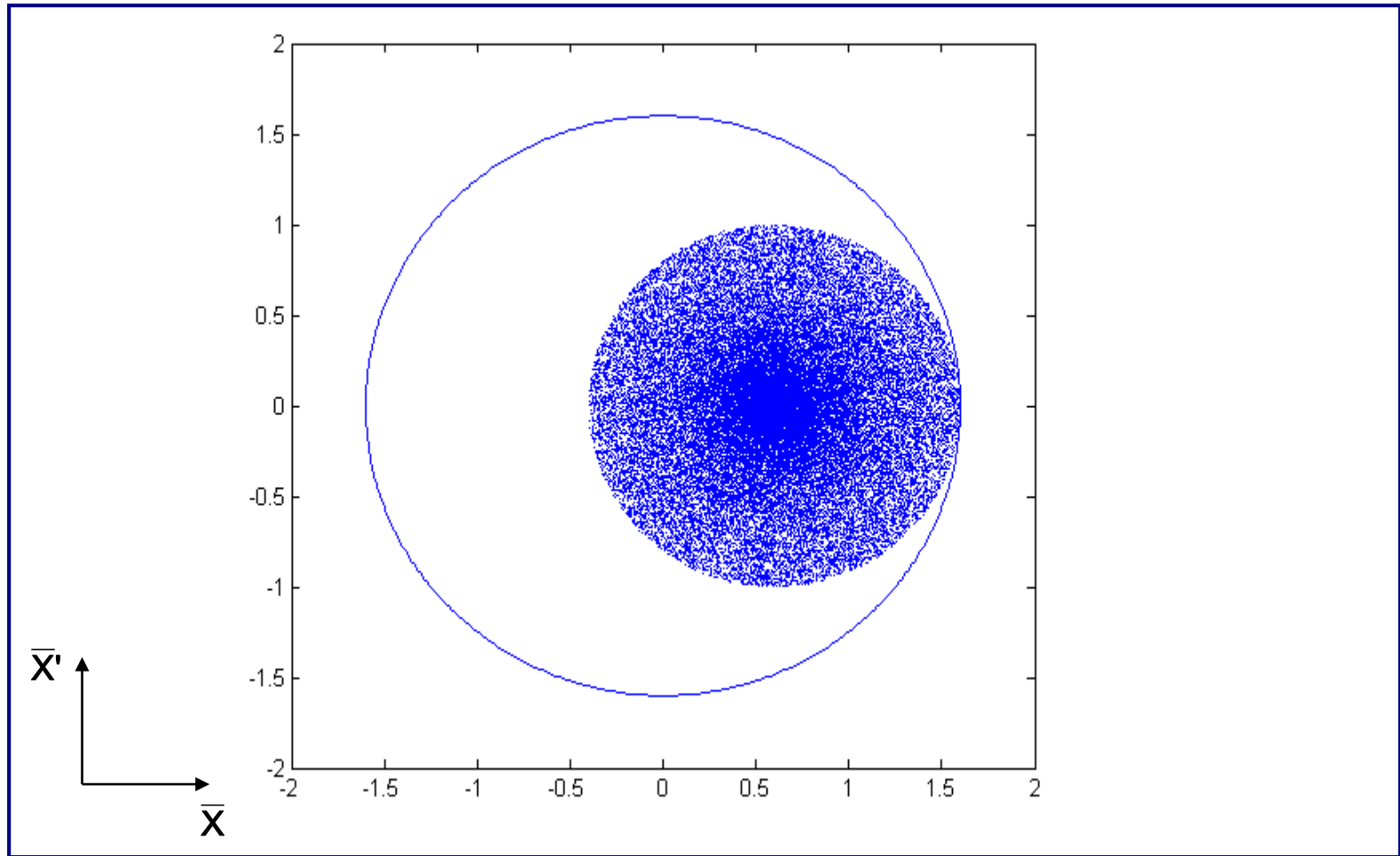

Filamentation

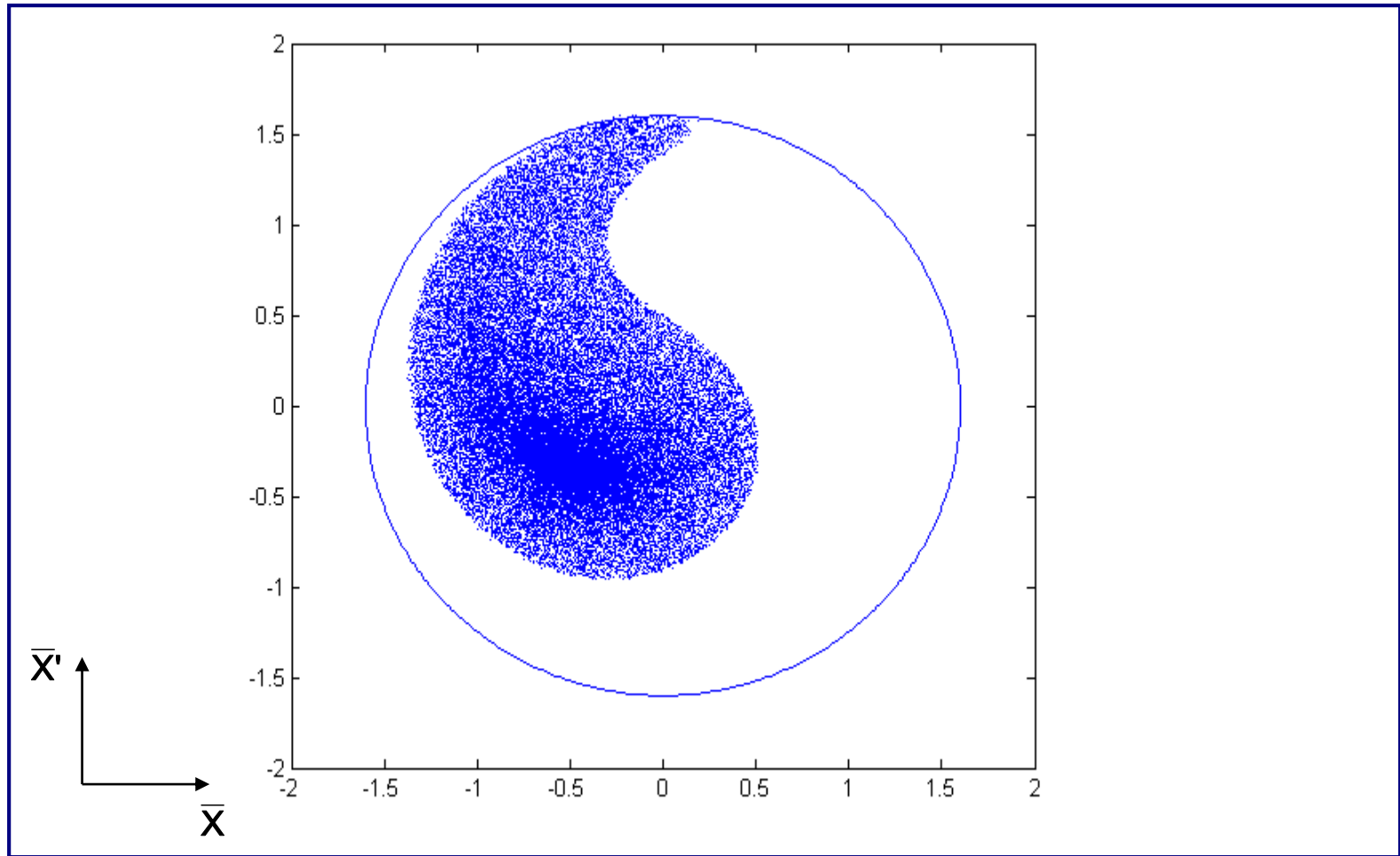

Filamentation

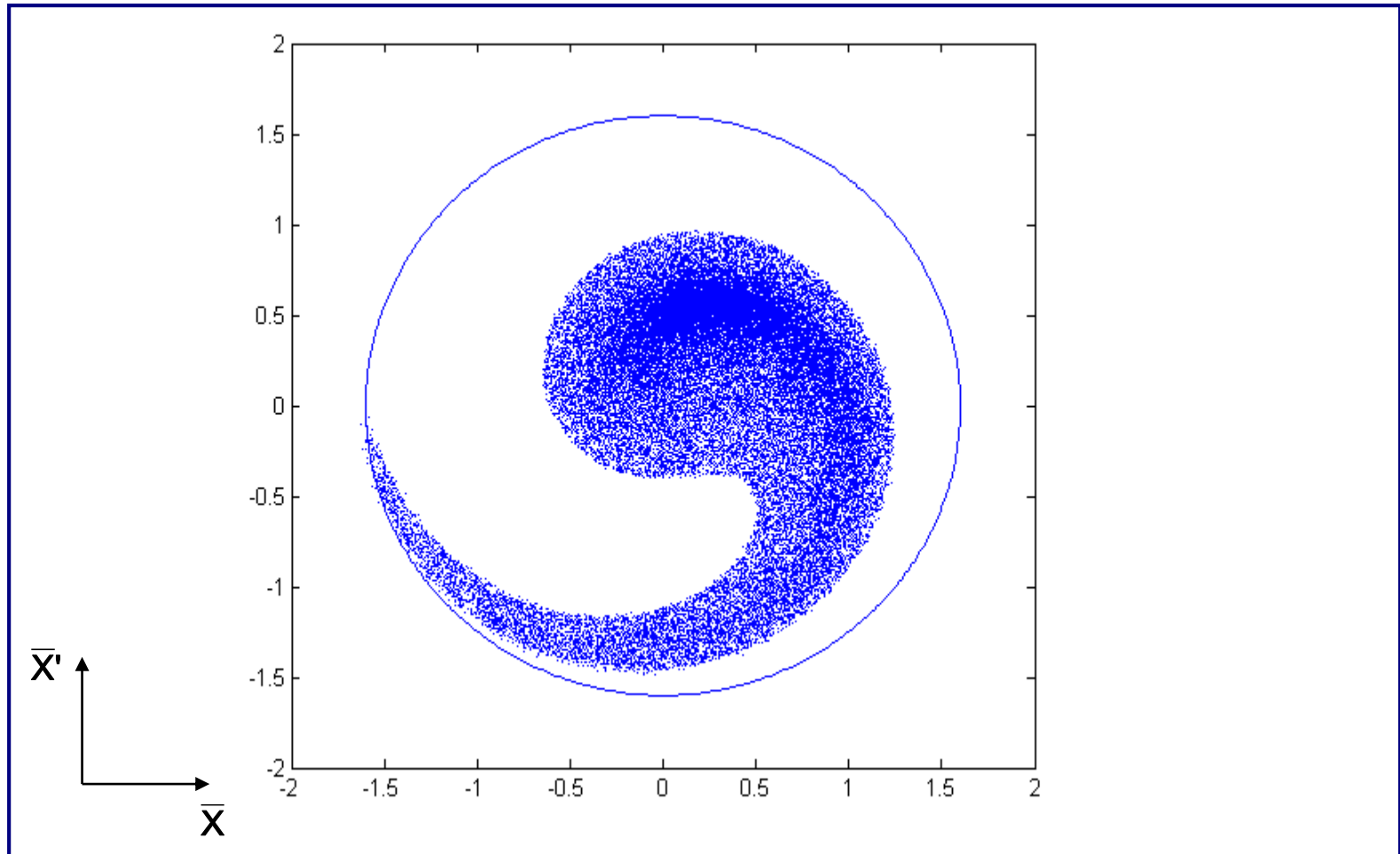

Filamentation

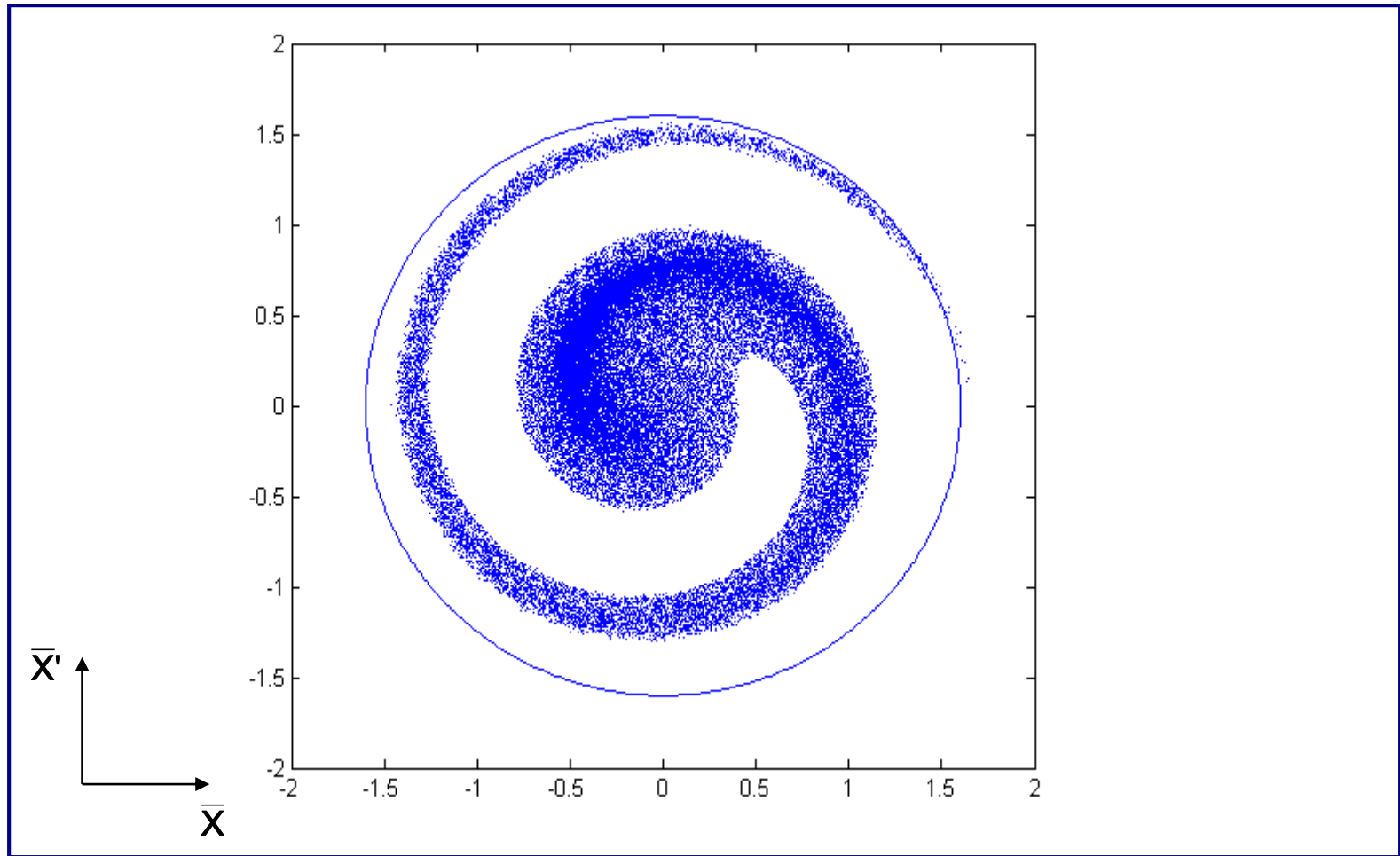

Filamentation

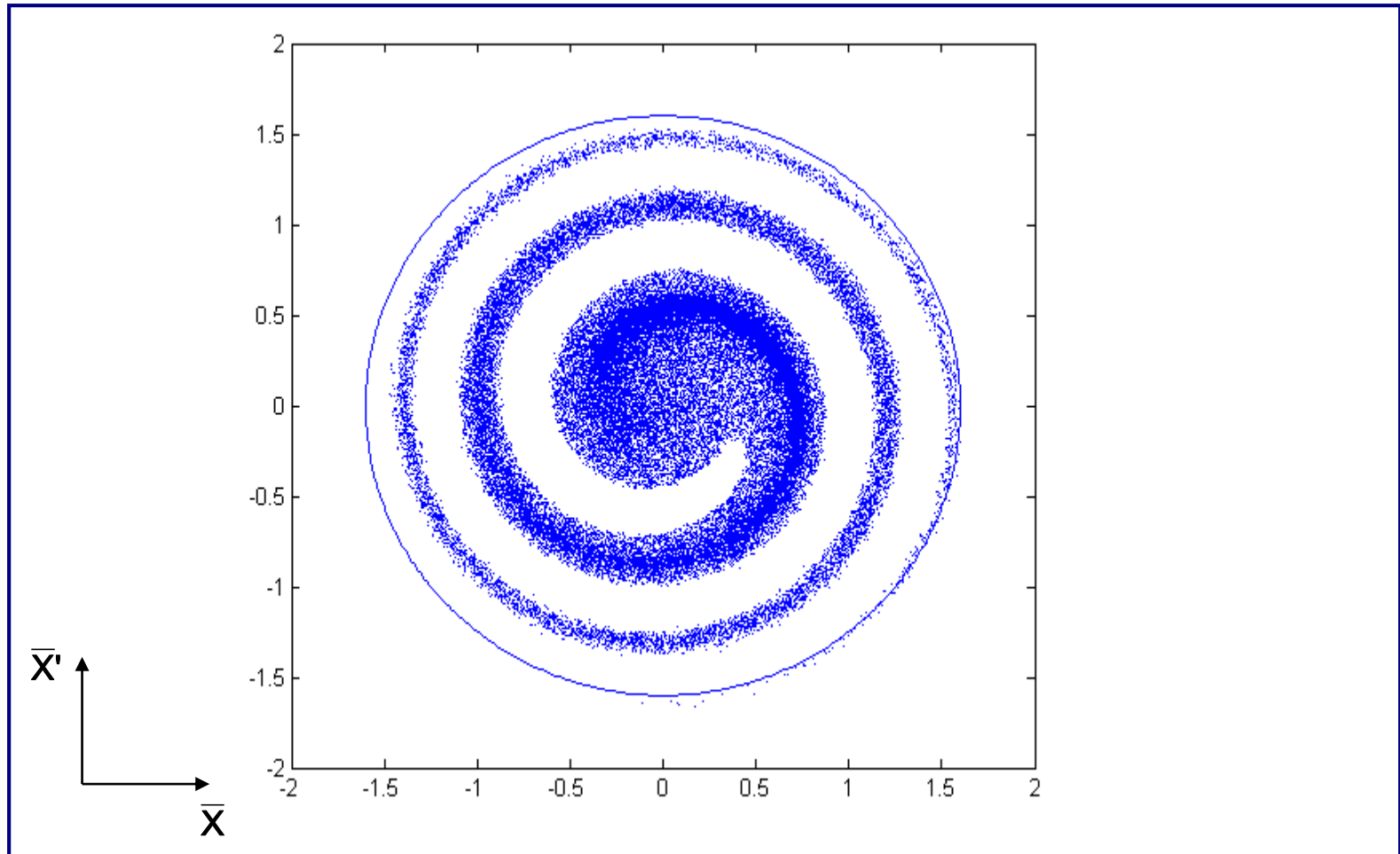

Filamentation

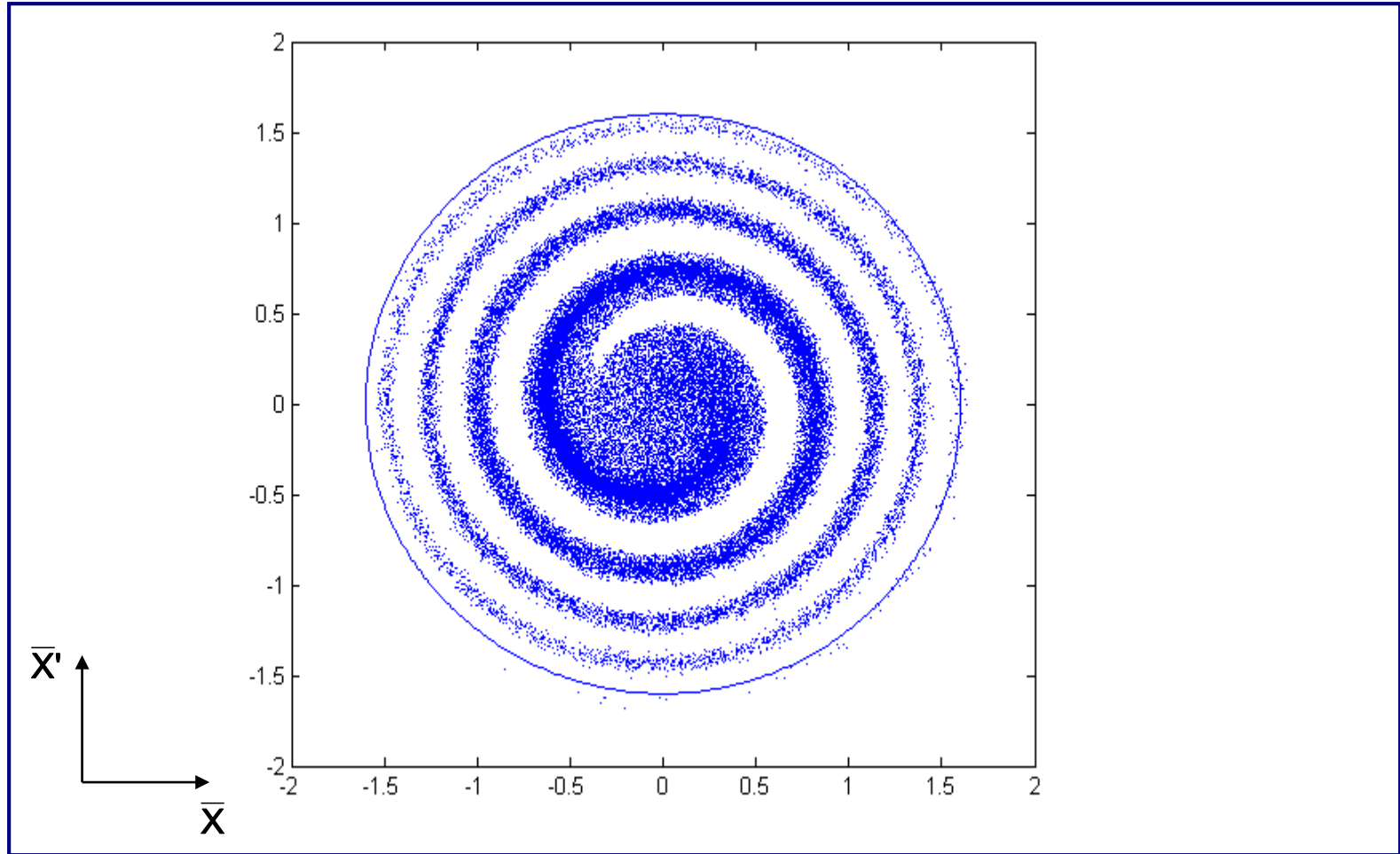

Filamentation

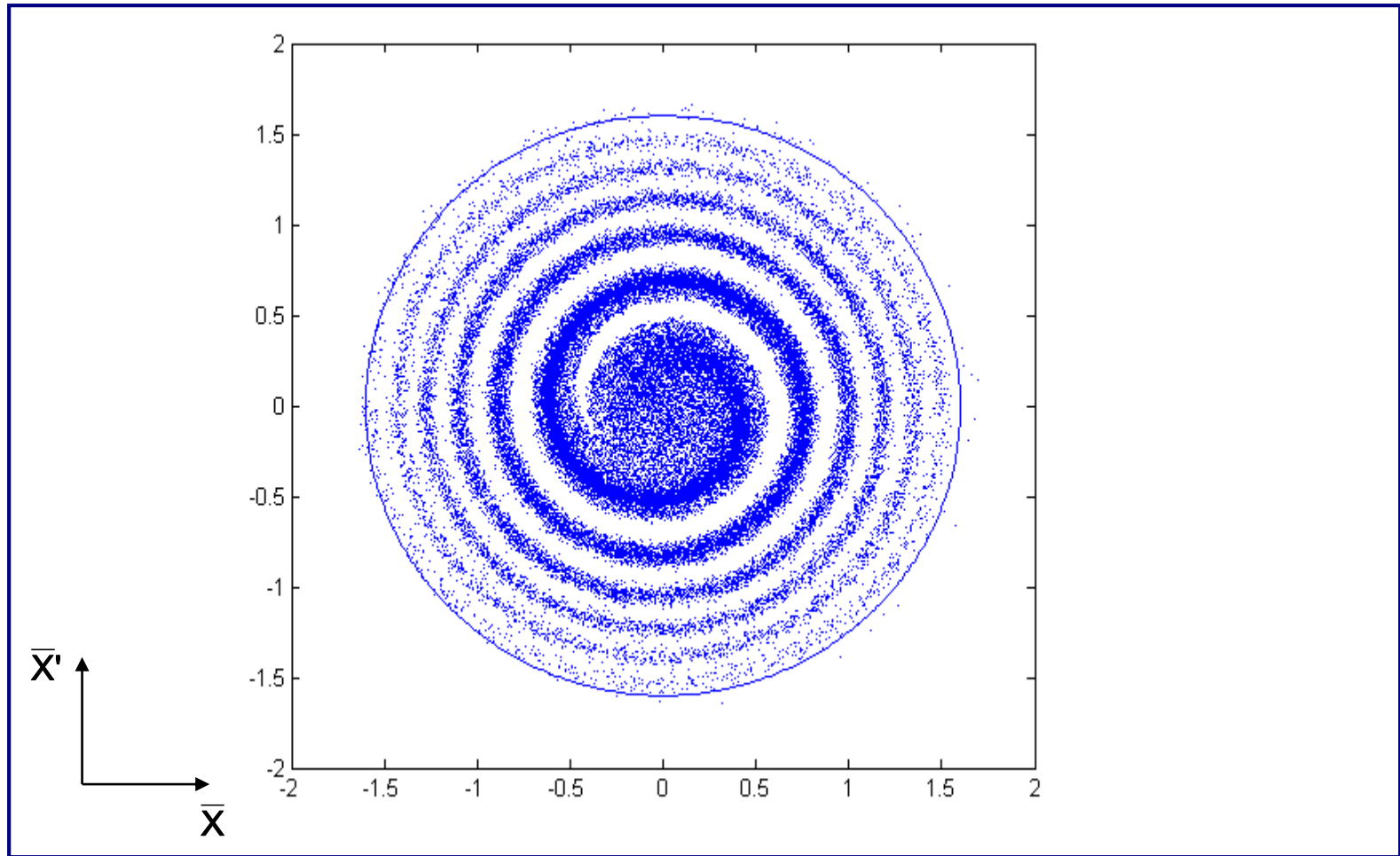

Filamentation

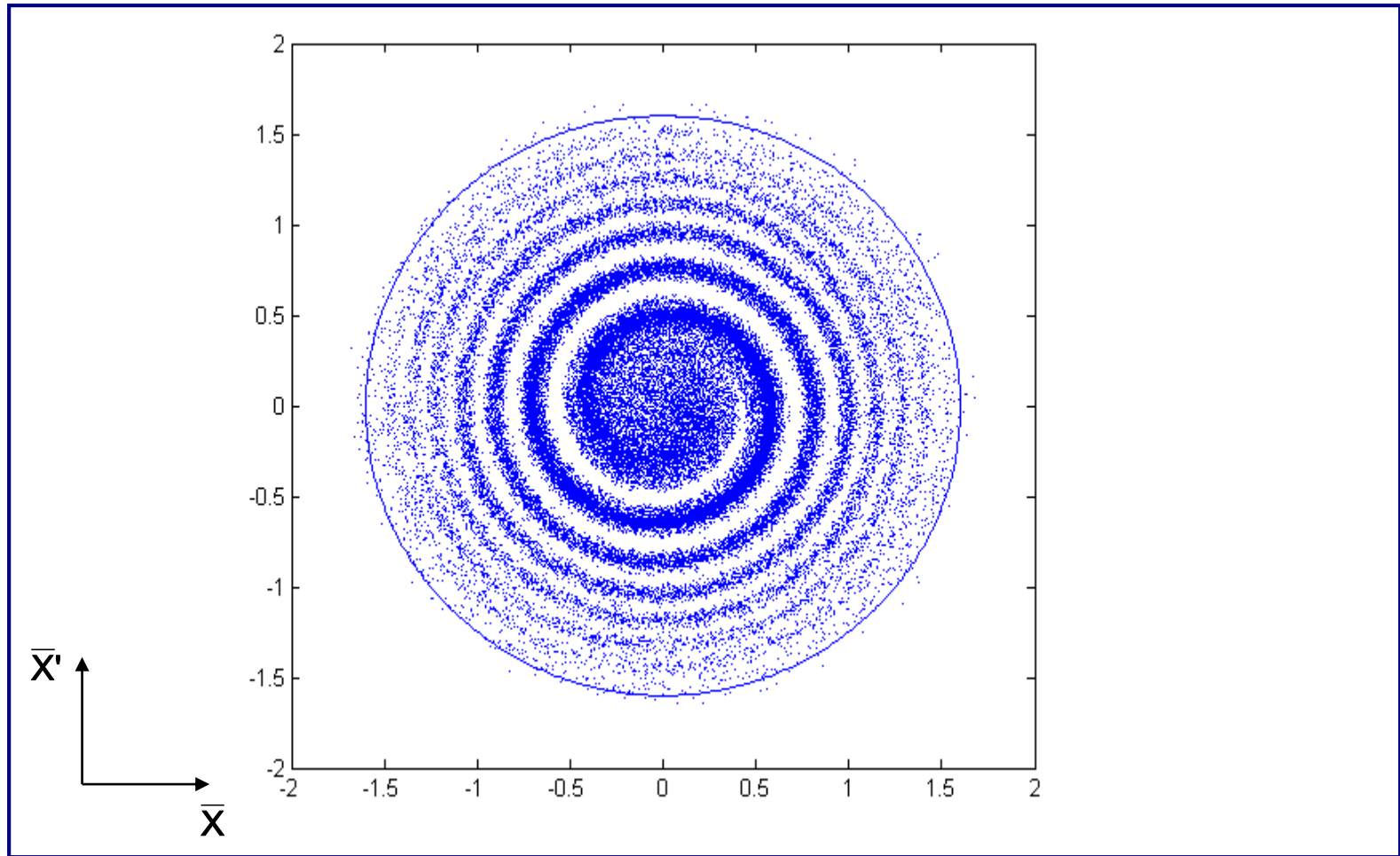

Filamentation

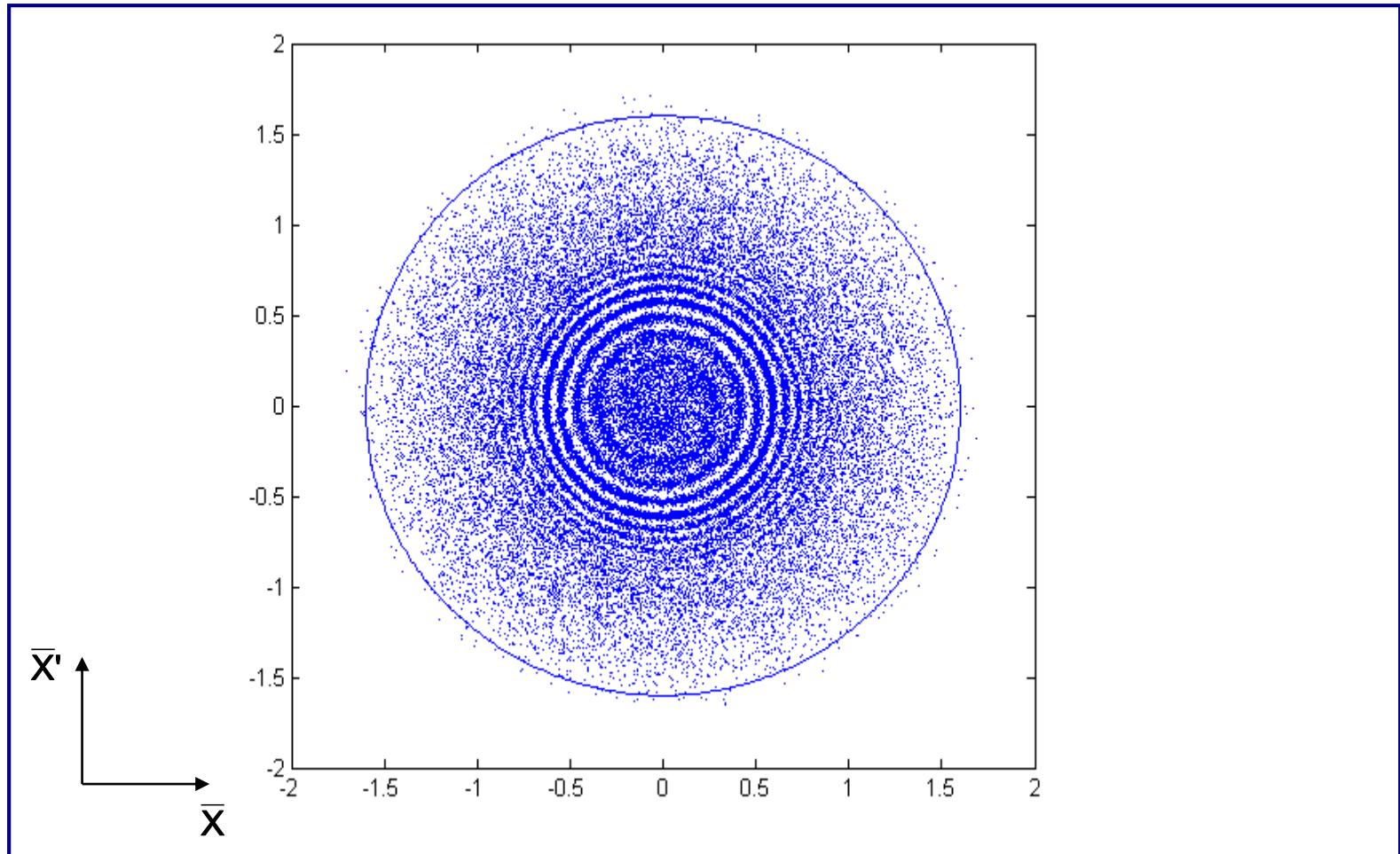

Filamentation

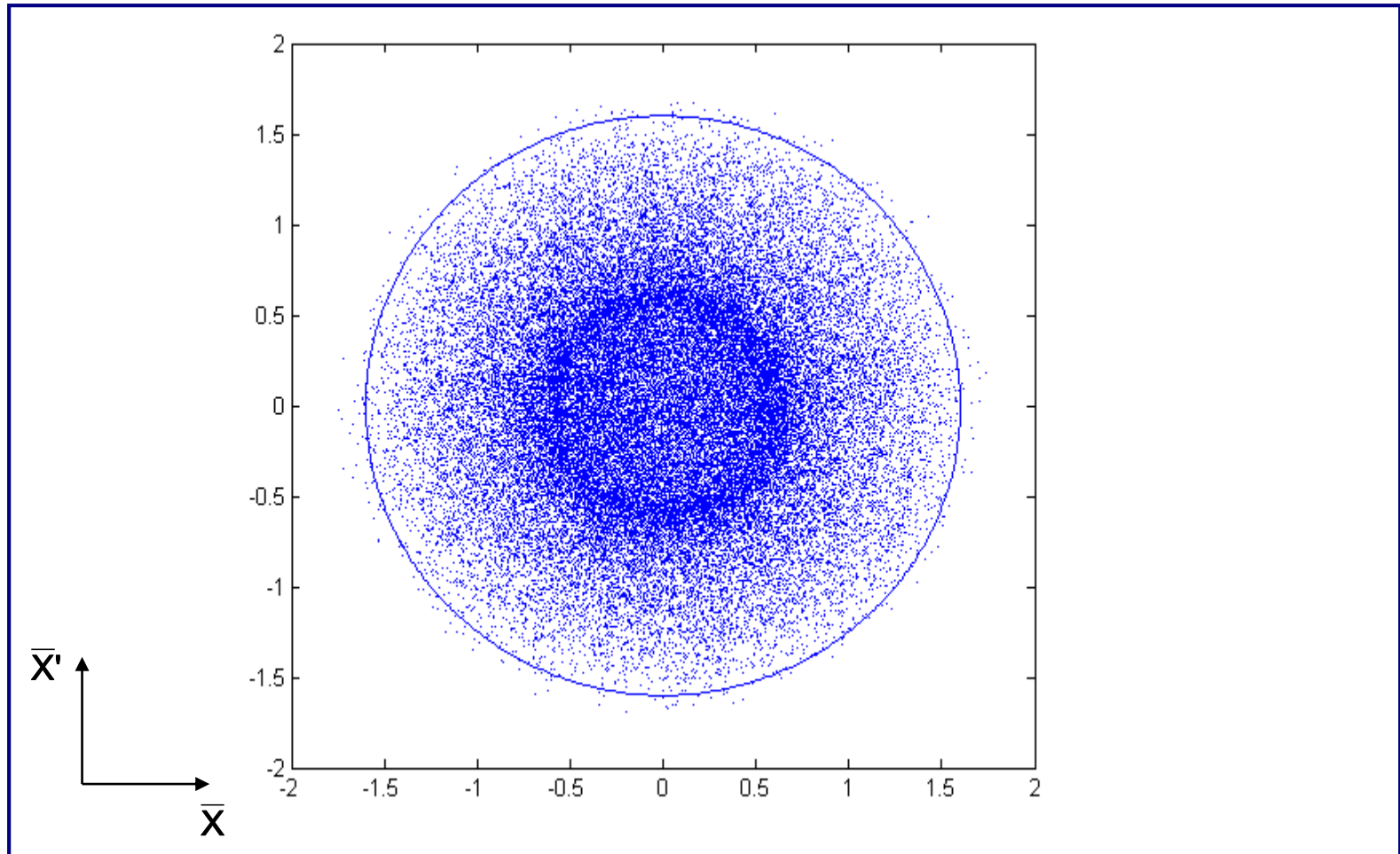

Filamentation - Decoherence

- Residual transverse oscillations lead to an *effective* emittance blow-up through filamentation.
- Due to tune spread and energy spread, the oscillation will not be seen for long on a BPM signal:

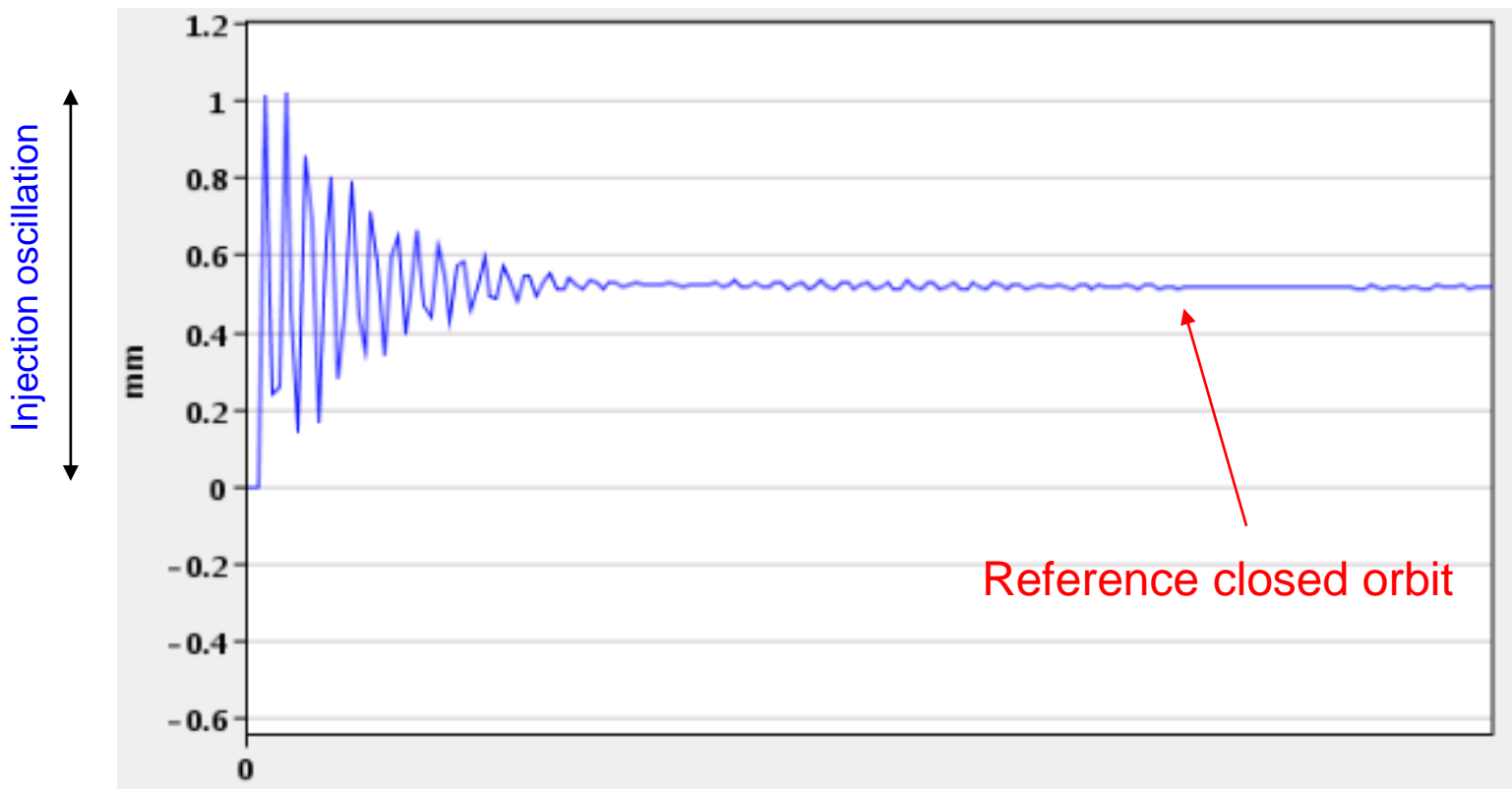

Multi-turn injection

- For hadrons the beam density at injection can be limited either by space charge effects or by the injector capacity
- If we cannot increase charge density, we can sometimes fill the horizontal phase space to increase overall injected intensity.
 - Cannot inject into same phase space area, as we would kick out the beam located there
 - If the acceptance of the receiving machine is larger than the delivered beam emittance we can accumulate intensity

Multi-turn injection for hadrons

**Injected beam
(usually from a linac)**

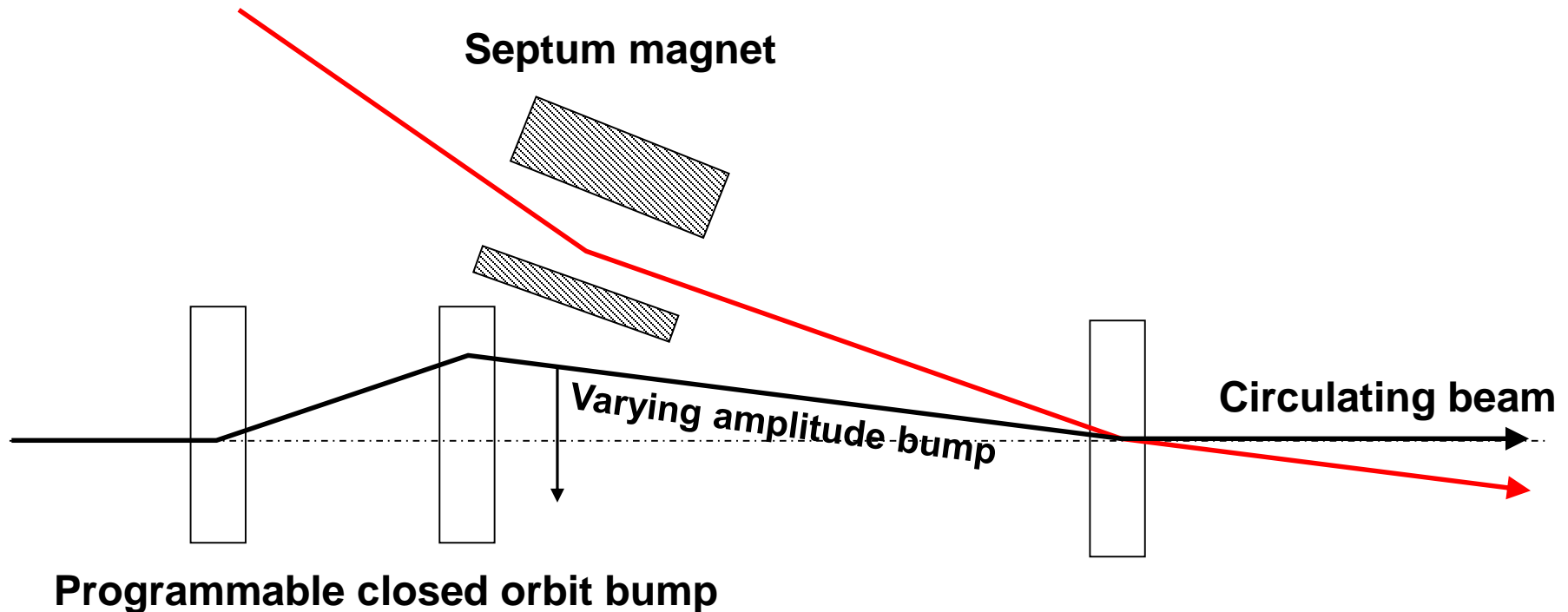

- No kicker but fast programmable bumpers
- Bump amplitude decreases and a new batch injected turn-by-turn
- Phase-space "painting"

Multi-turn injection for hadrons

Example: CERN PSB injection, high intensity beams, fractional tune $Q_h \approx 0.25$

Beam rotates $\pi/2$ per turn in phase space

Turn 1

On each turn inject a new batch and reduce the bump amplitude

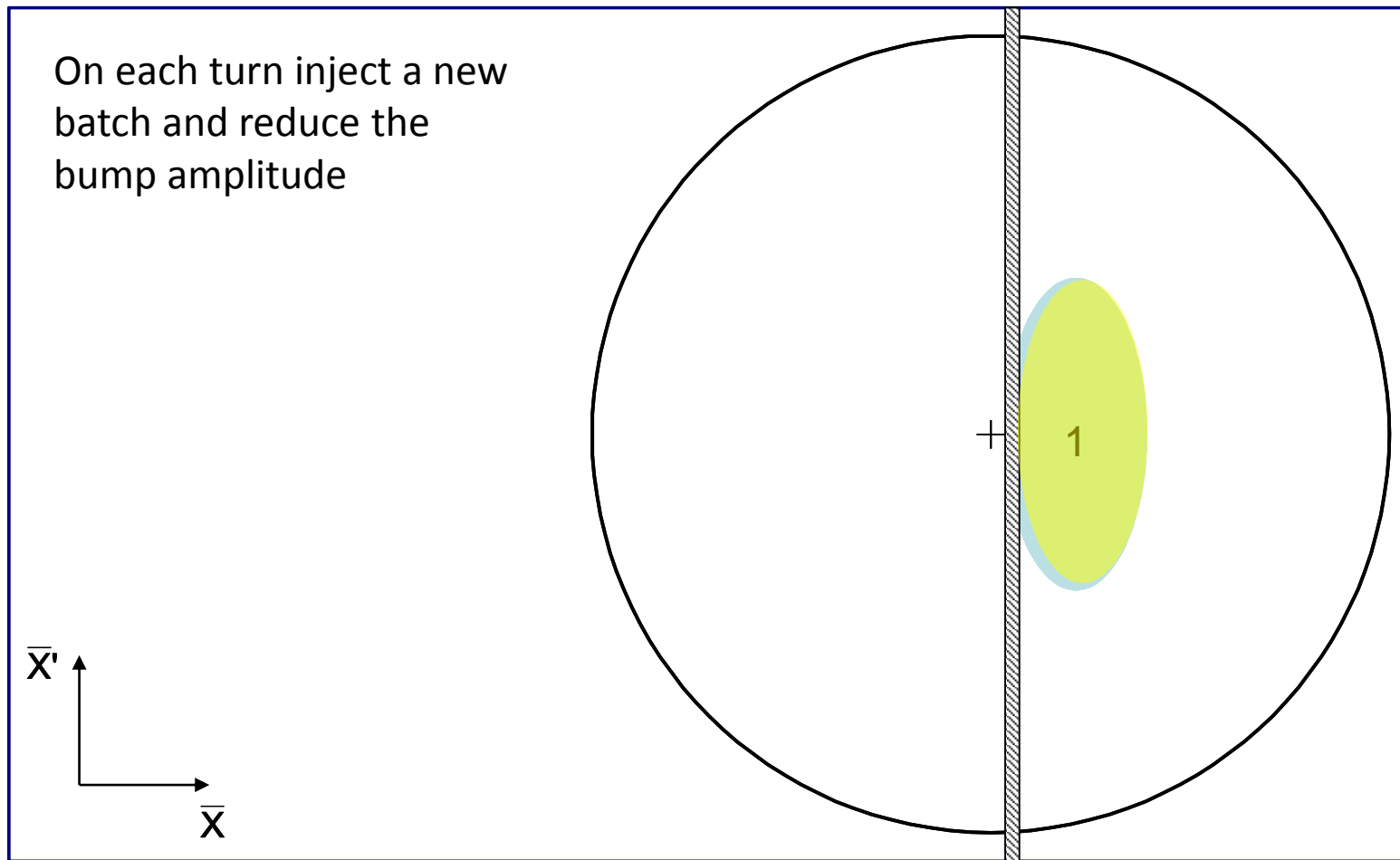

Septum

Multi-turn injection for hadrons

Example: CERN PSB injection, high intensity beams, fractional tune $Q_h \approx 0.25$

Beam rotates $\pi/2$ per turn in phase space

Turn 2

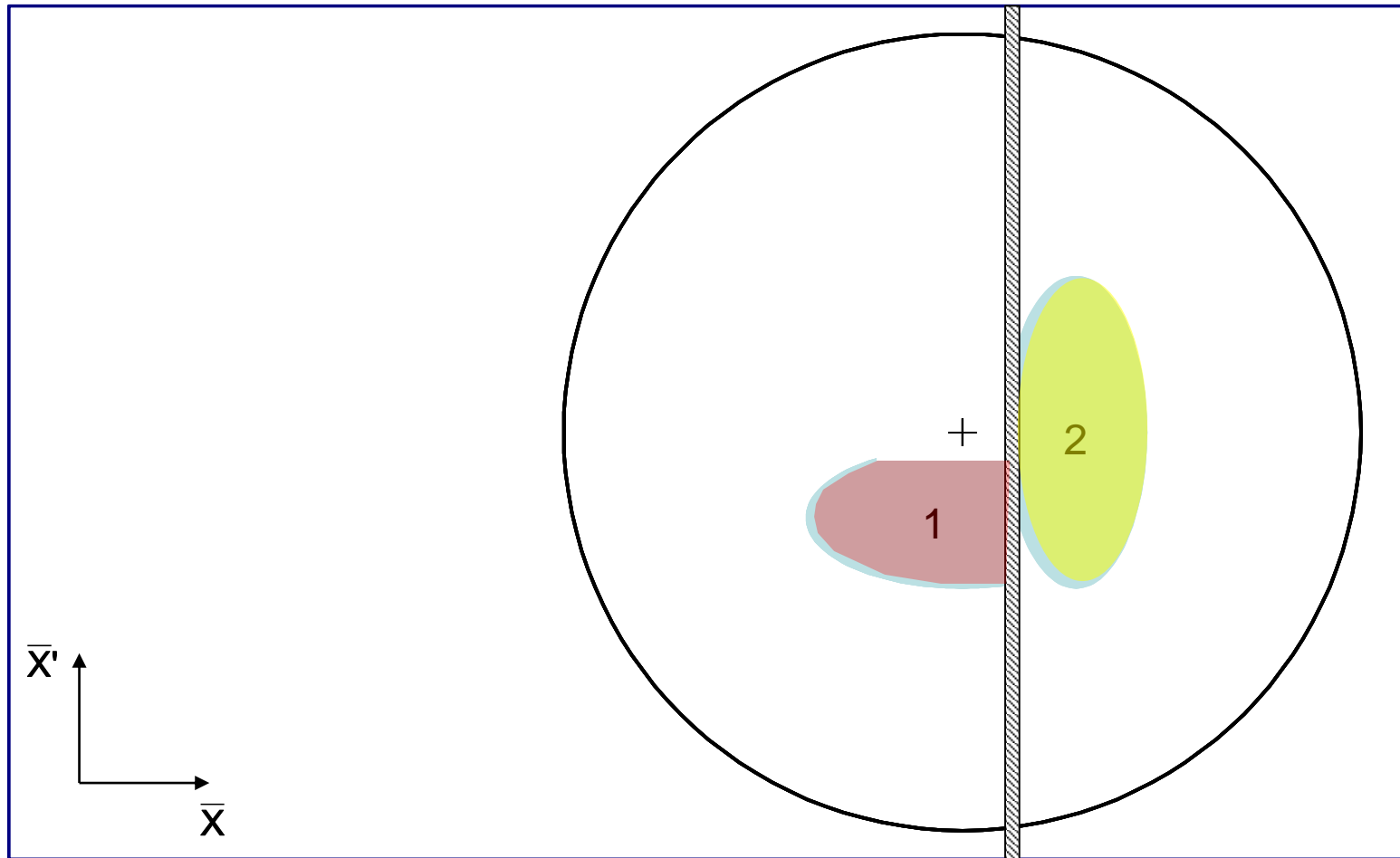

Septum

Multi-turn injection for hadrons

Example: CERN PSB injection, high intensity beams, fractional tune $Q_h \approx 0.25$

Beam rotates $\pi/2$ per turn in phase space

Turn 3

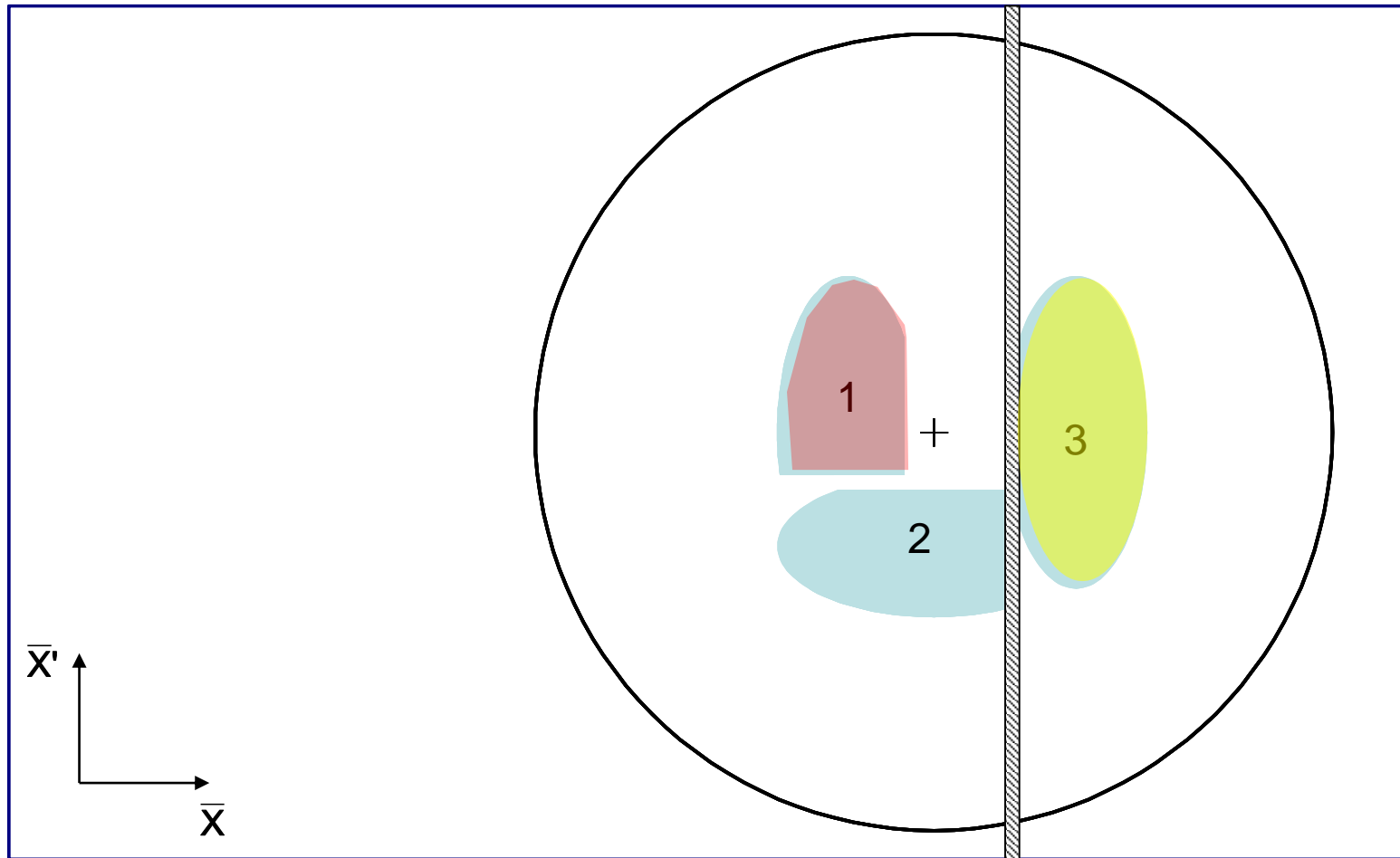

Septum

Multi-turn injection for hadrons

Example: CERN PSB injection, high intensity beams, fractional tune $Q_h \approx 0.25$

Beam rotates $\pi/2$ per turn in phase space

Turn 4

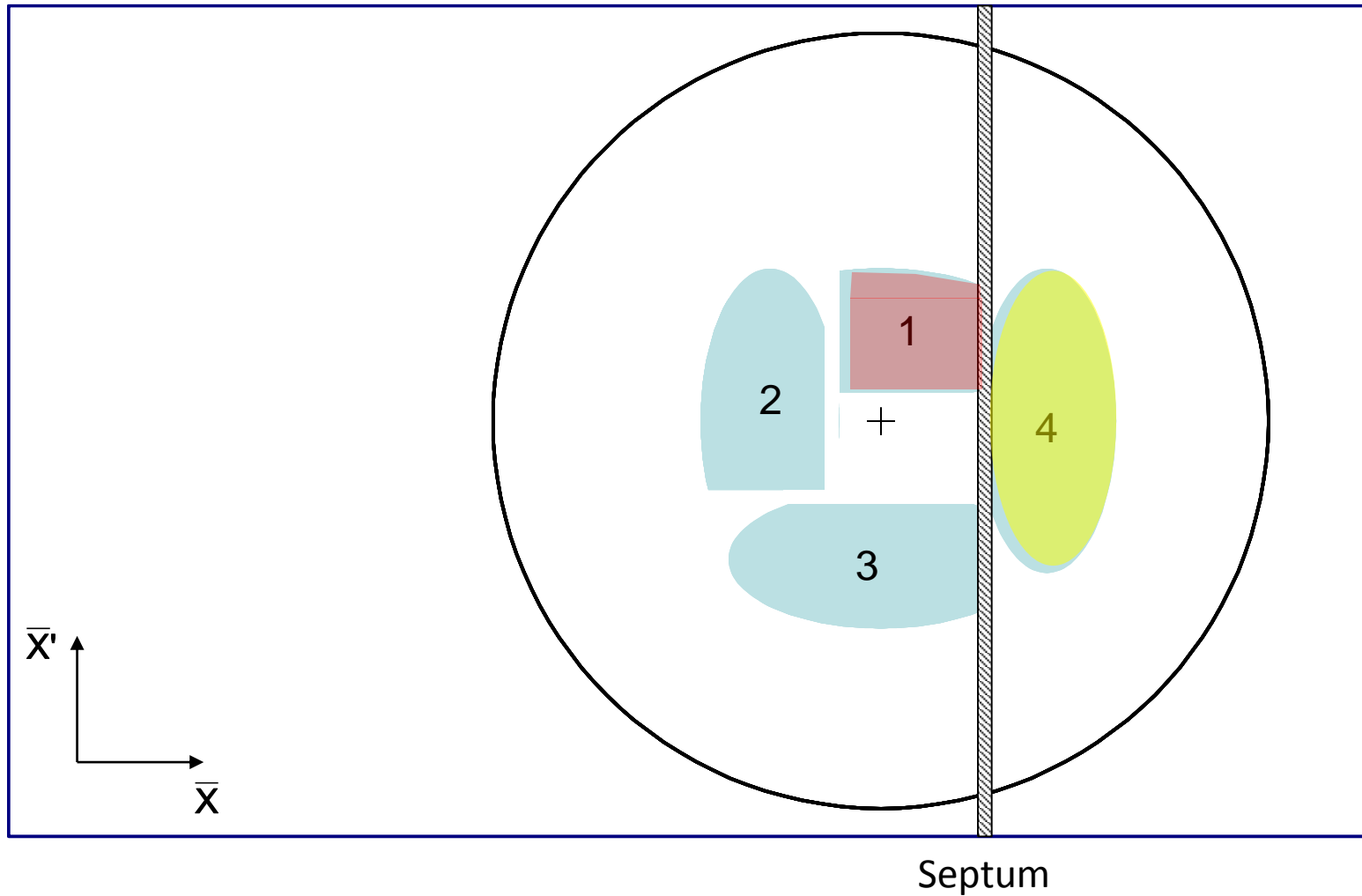

Multi-turn injection for hadrons

Example: CERN PSB injection, high intensity beams, fractional tune $Q_h \approx 0.25$

Beam rotates $\pi/2$ per turn in phase space

Turn 5

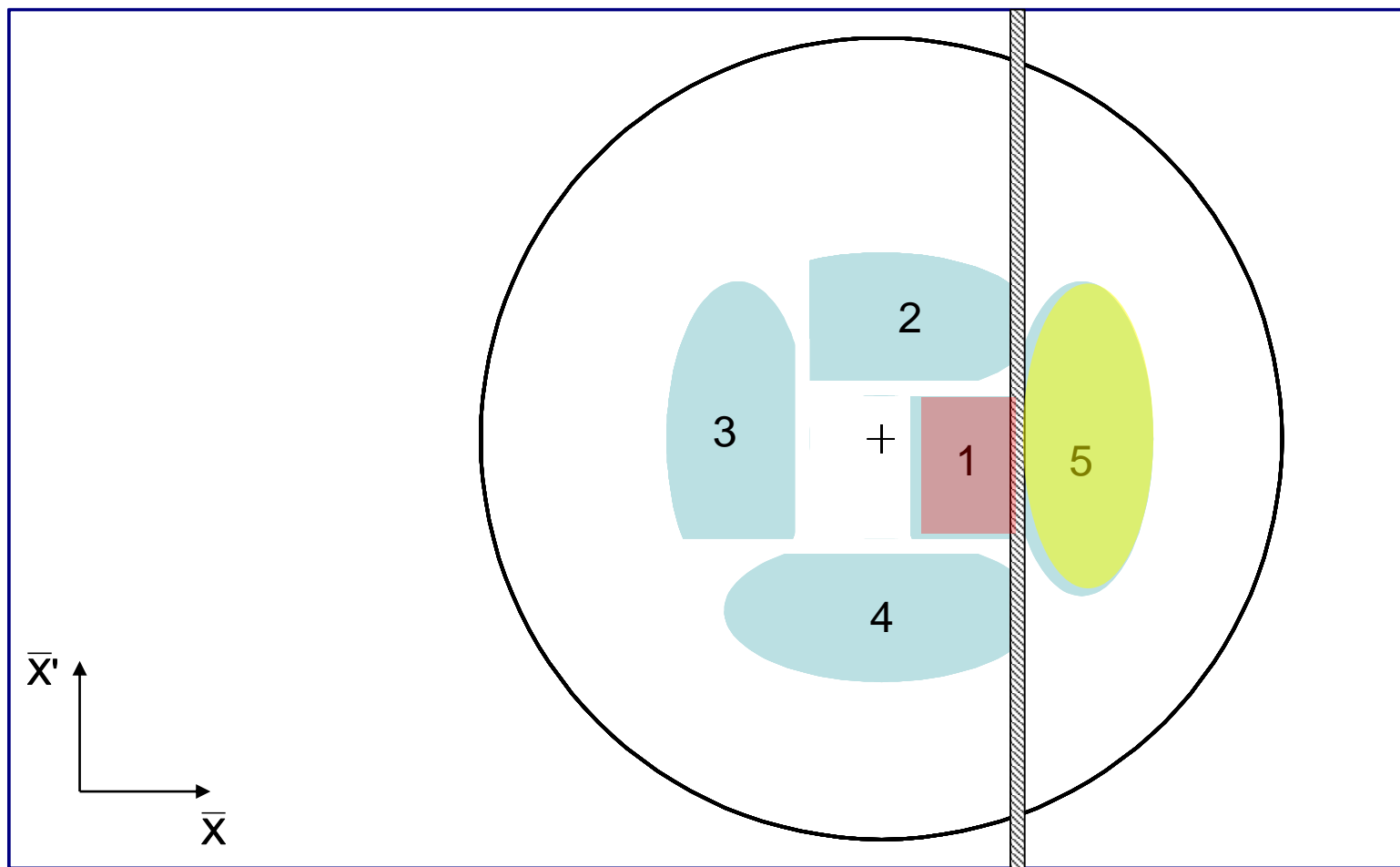

Septum

Multi-turn injection for hadrons

Example: CERN PSB injection, high intensity beams, fractional tune $Q_h \approx 0.25$

Beam rotates $\pi/2$ per turn in phase space

Turn 6

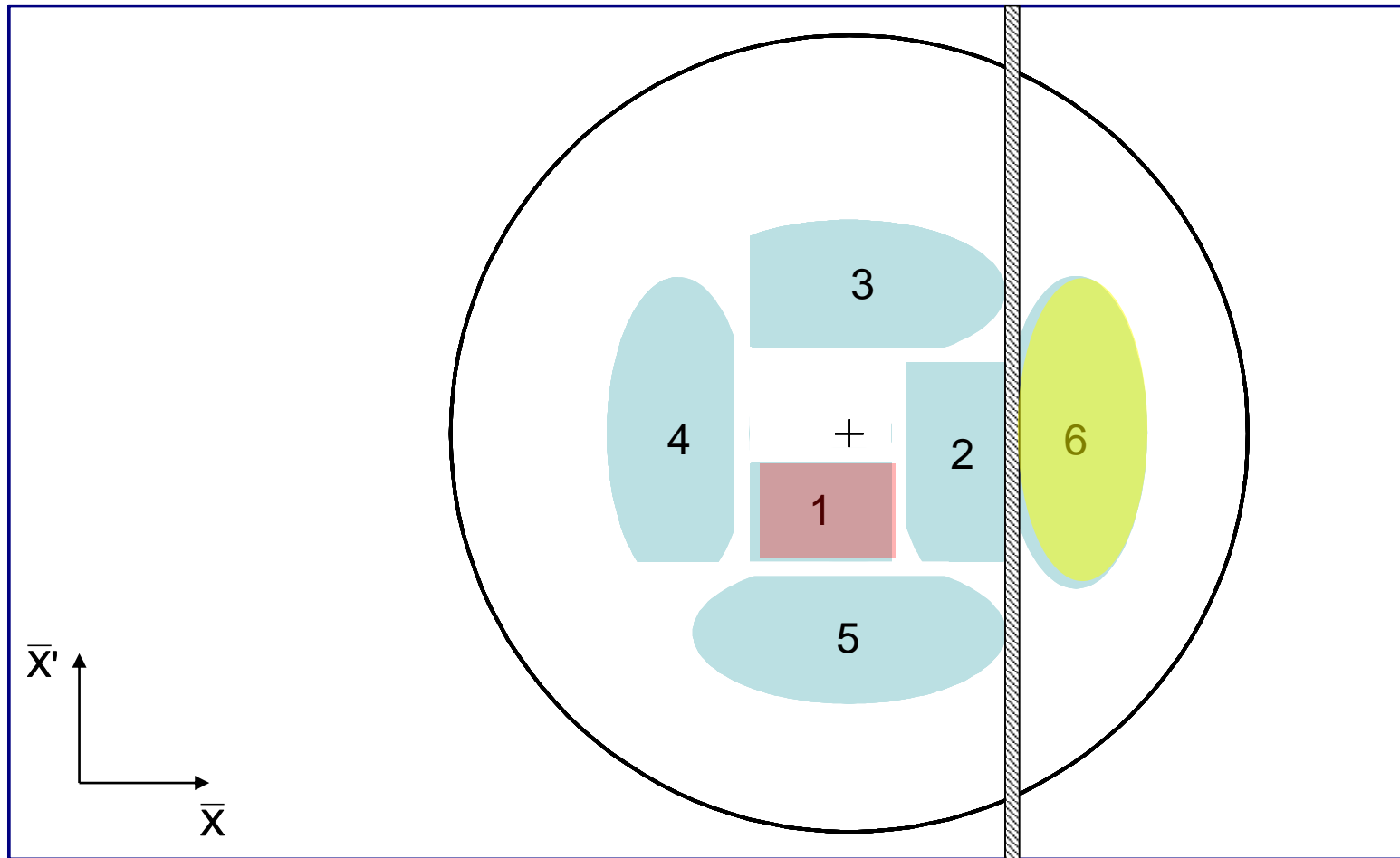

Septum

Multi-turn injection for hadrons

Example: CERN PSB injection, high intensity beams, fractional tune $Q_h \approx 0.25$

Beam rotates $\pi/2$ per turn in phase space

Turn 7

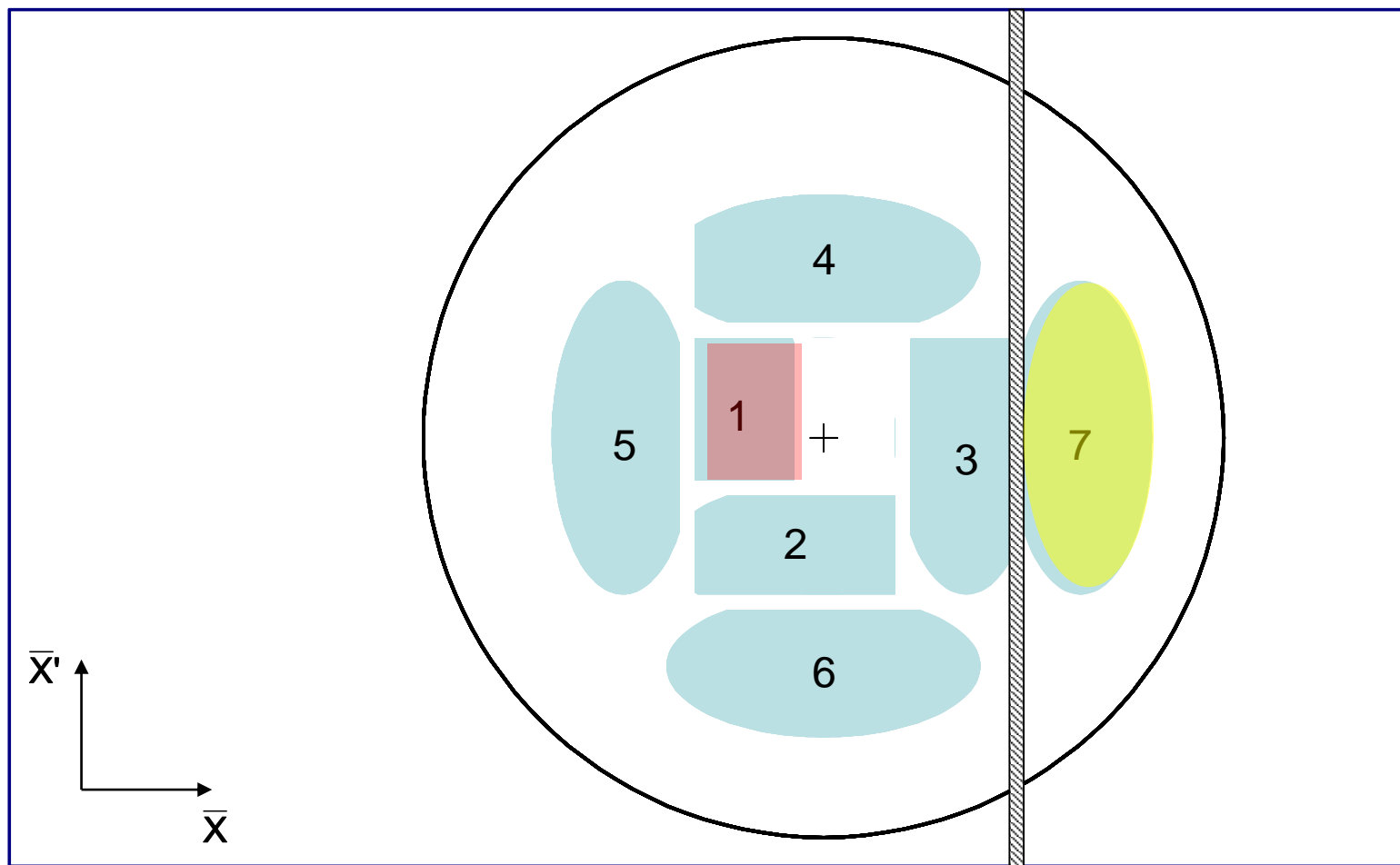

Septum

Multi-turn injection for hadrons

Example: CERN PSB injection, high intensity beams, fractional tune $Q_h \approx 0.25$

Beam rotates $\pi/2$ per turn in phase space

Turn 8

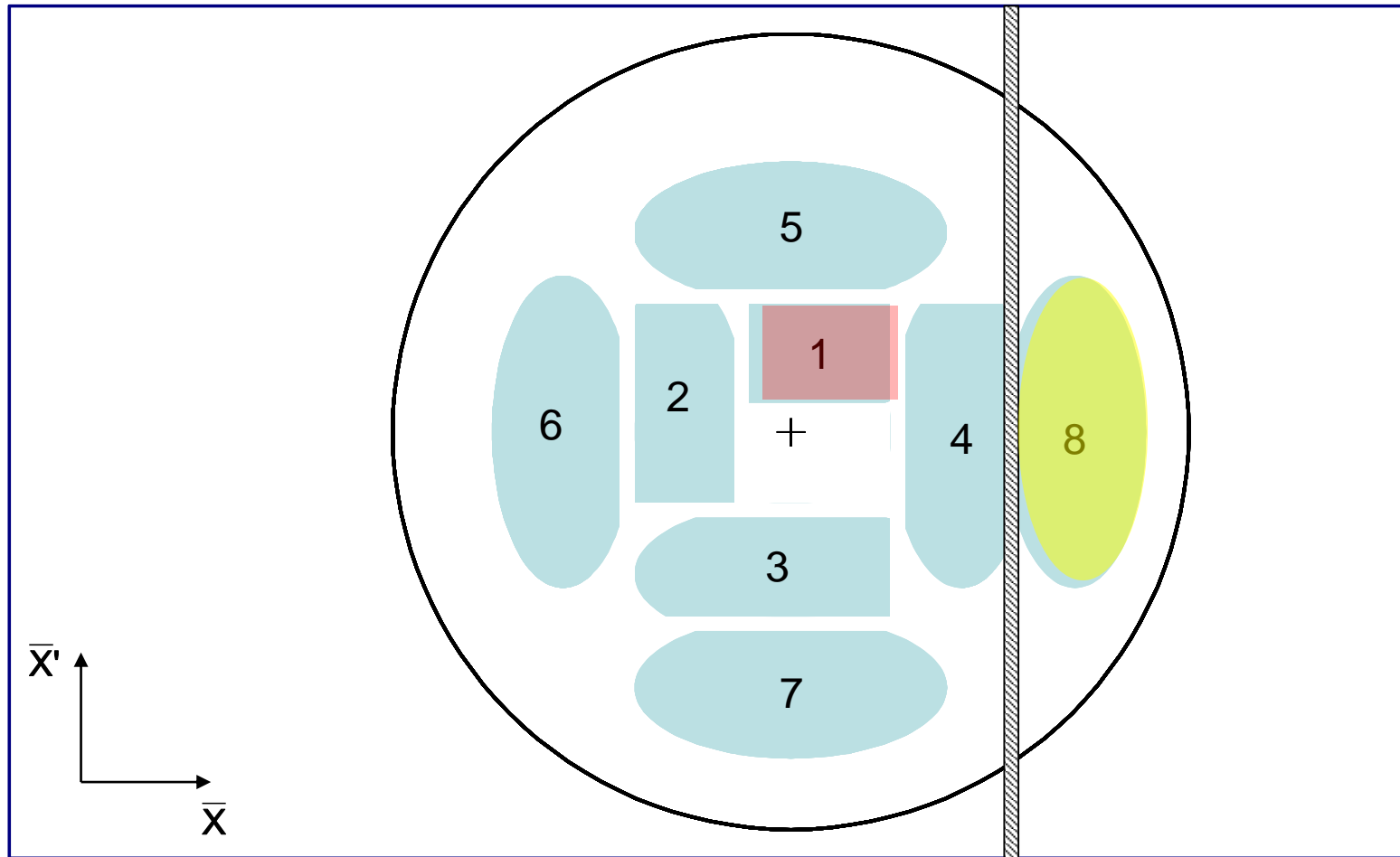

Septum

Multi-turn injection for hadrons

Example: CERN PSB injection, high intensity beams, fractional tune $Q_h \approx 0.25$

Beam rotates $\pi/2$ per turn in phase space

Turn 9

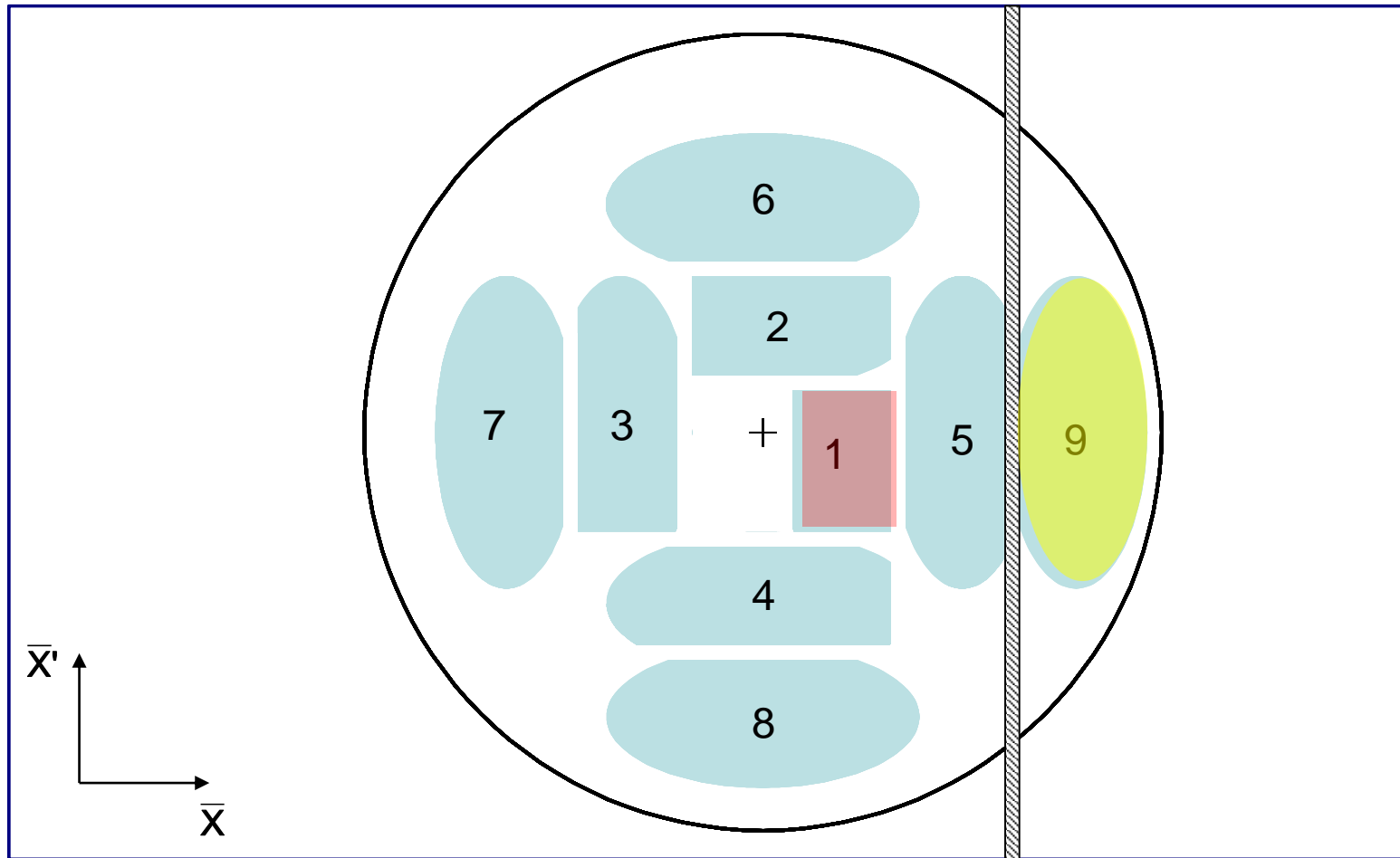

Septum

Multi-turn injection for hadrons

Example: CERN PSB injection, high intensity beams, fractional tune $Q_h \approx 0.25$

Beam rotates $\pi/2$ per turn in phase space

Turn 10

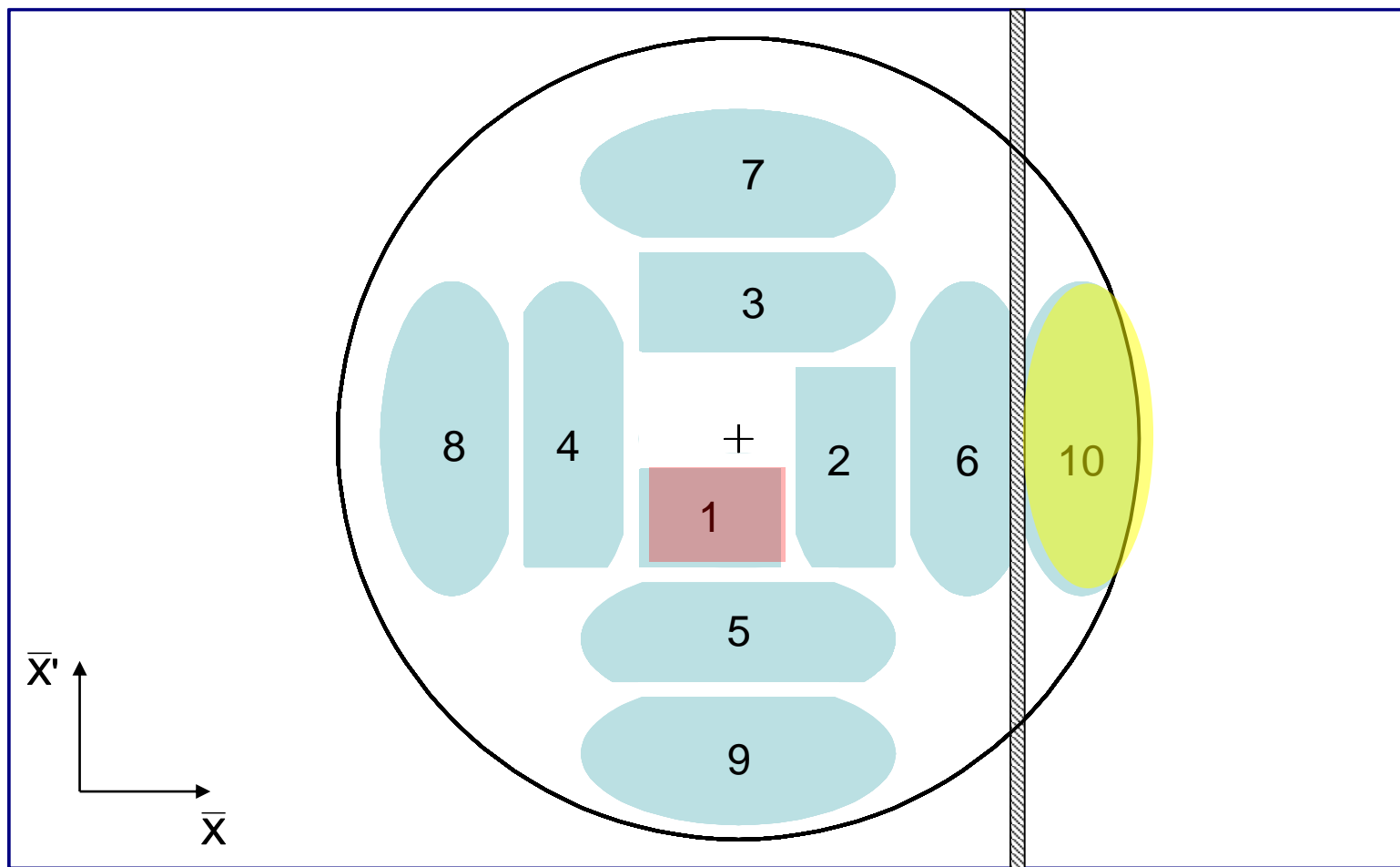

Septum

Multi-turn injection for hadrons

Example: CERN PSB injection, high intensity beams, fractional tune $Q_h \approx 0.25$

Beam rotates $\pi/2$ per turn in phase space

Turn 11

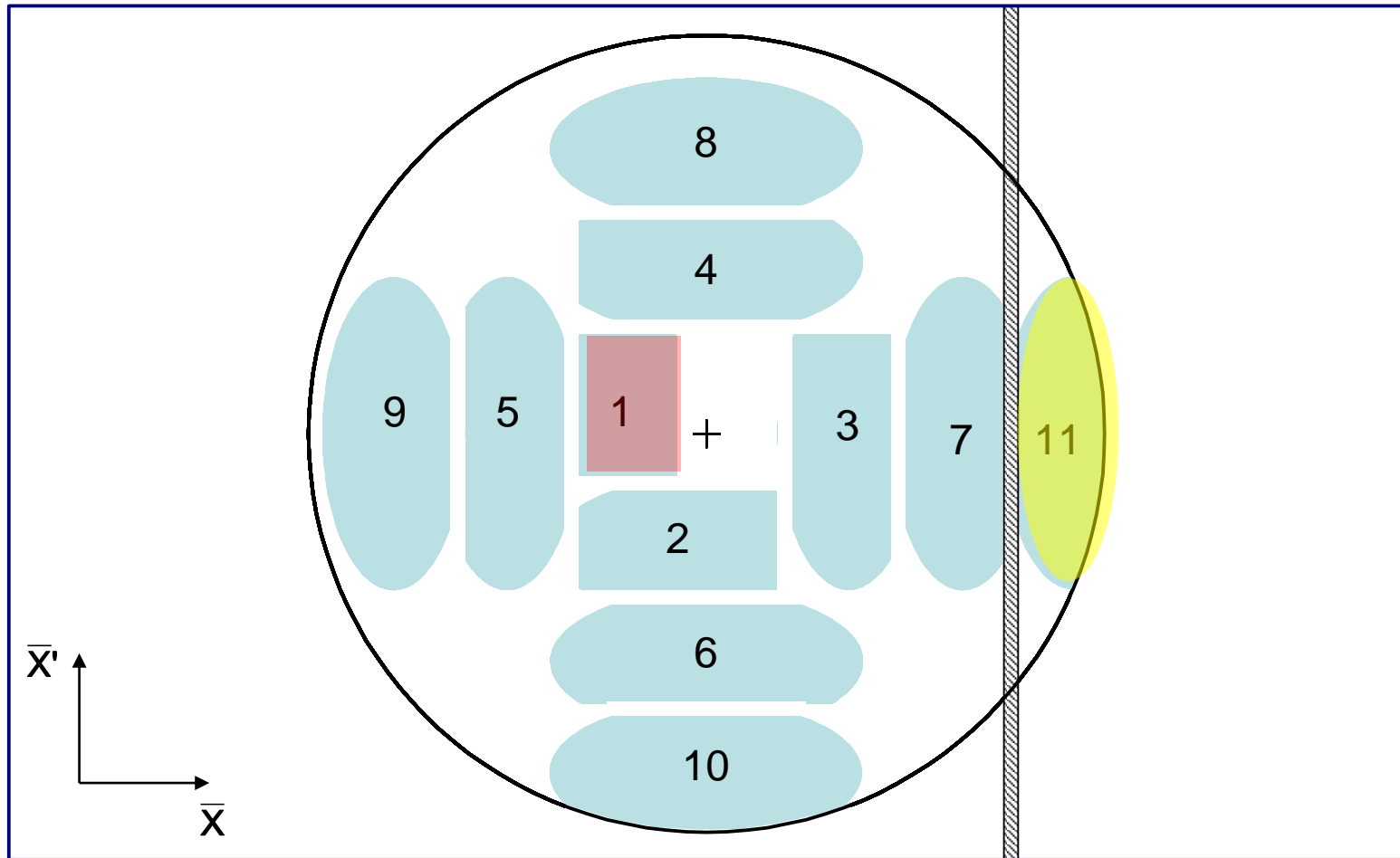

Septum

Multi-turn injection for hadrons

Example: CERN PSB injection, high intensity beams, fractional tune $Q_h \approx 0.25$

Beam rotates $\pi/2$ per turn in phase space

Turn 12

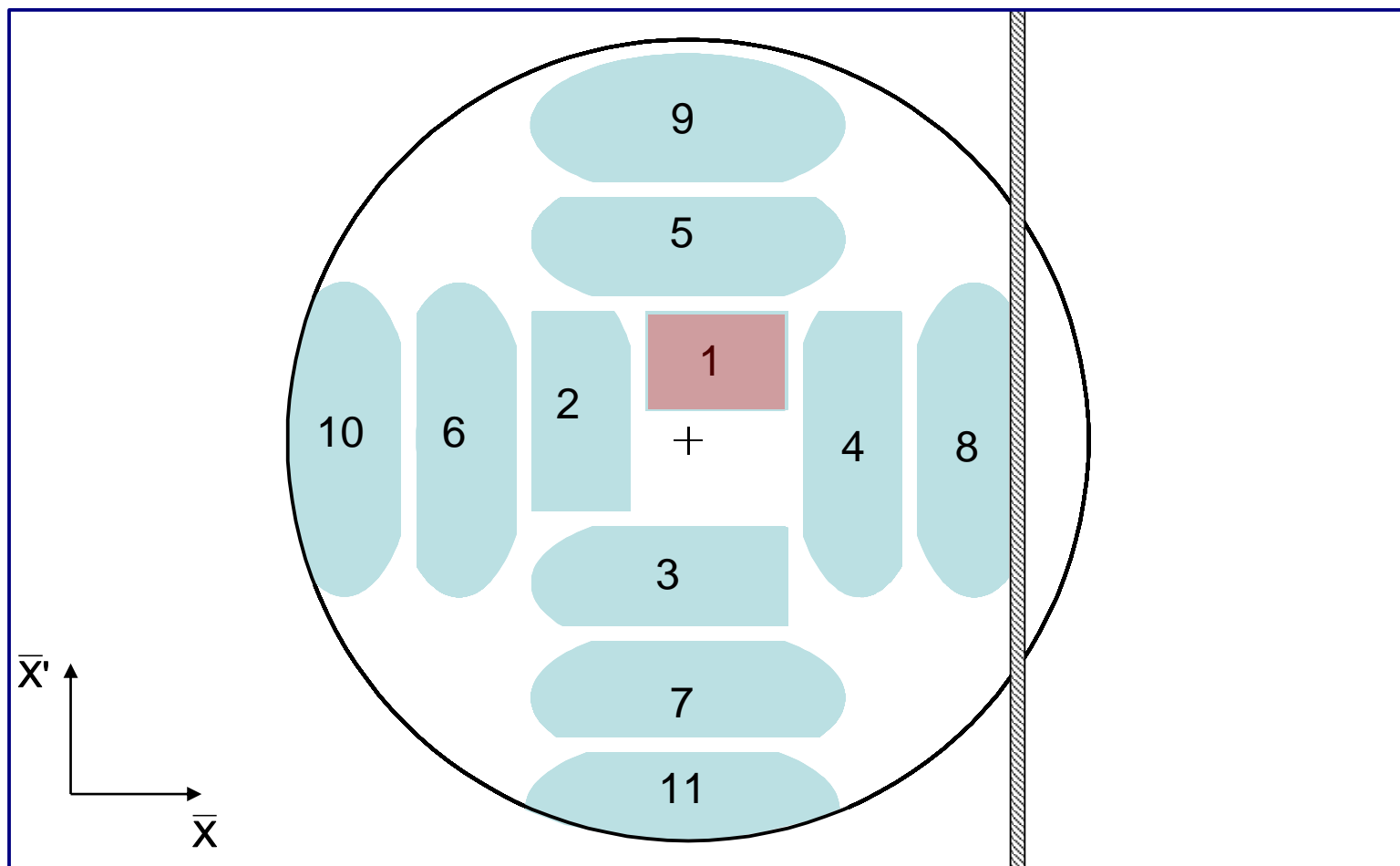

Septum

Multi-turn injection for hadrons

Example: CERN PSB injection, high intensity beams, fractional tune $Q_h \approx 0.25$

Beam rotates $\pi/2$ per turn in phase space

Turn 13

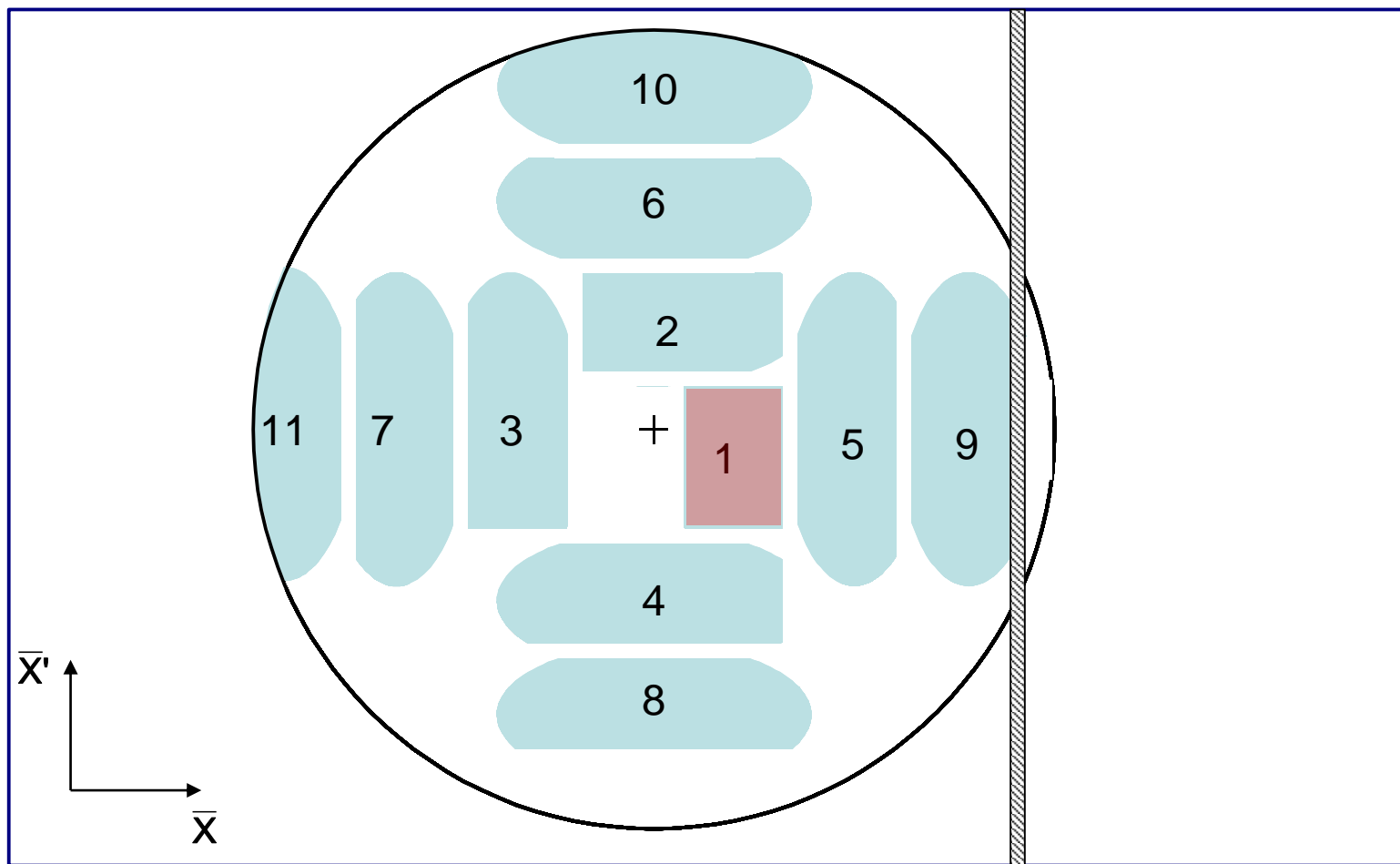

Septum

Multi-turn injection for hadrons

Example: CERN PSB injection, high intensity beams, fractional tune $Q_h \approx 0.25$

Beam rotates $\pi/2$ per turn in phase space

Turn 14

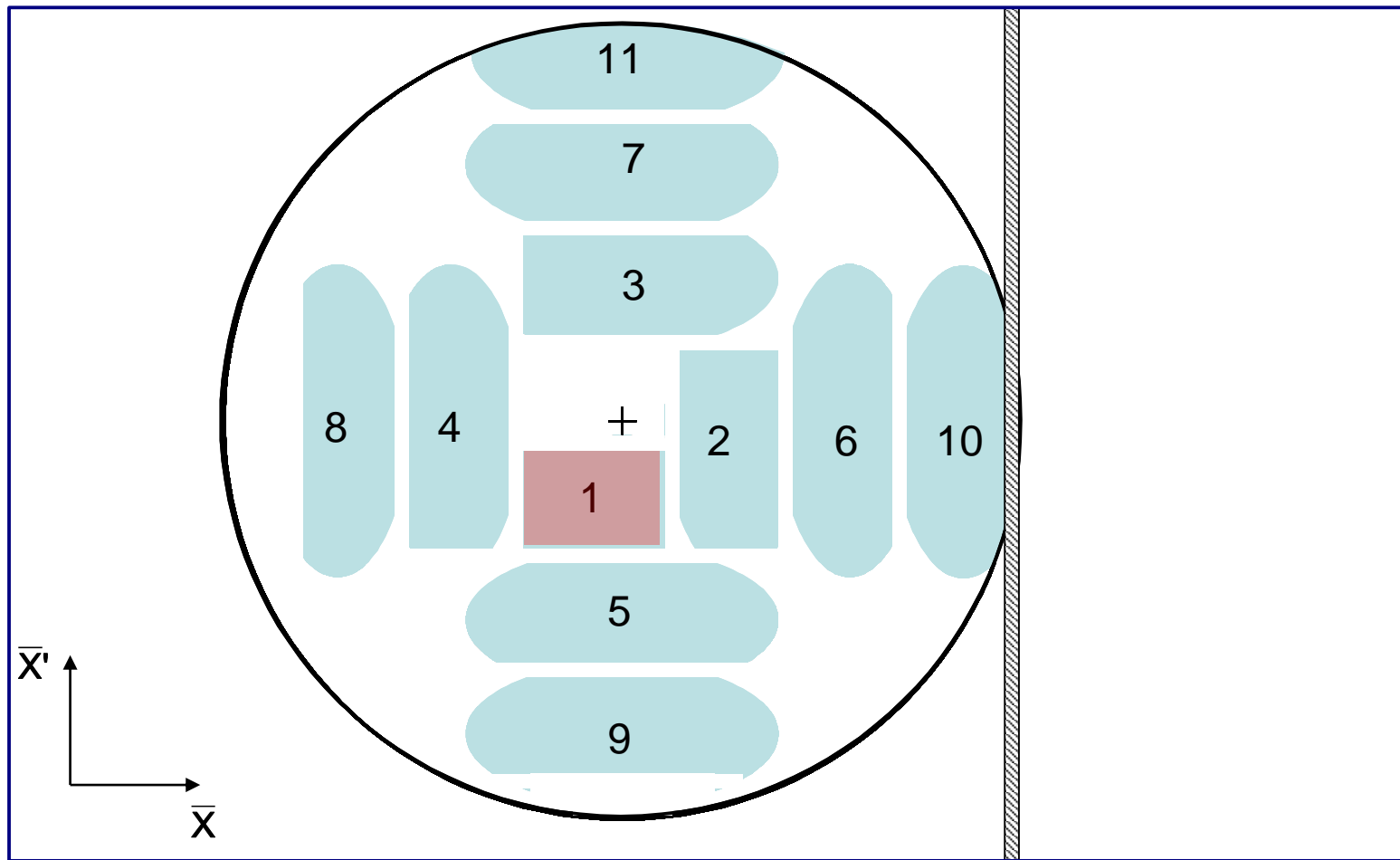

Septum

Multi-turn injection for hadrons

Phase space has been “**painted**”

Turn 15

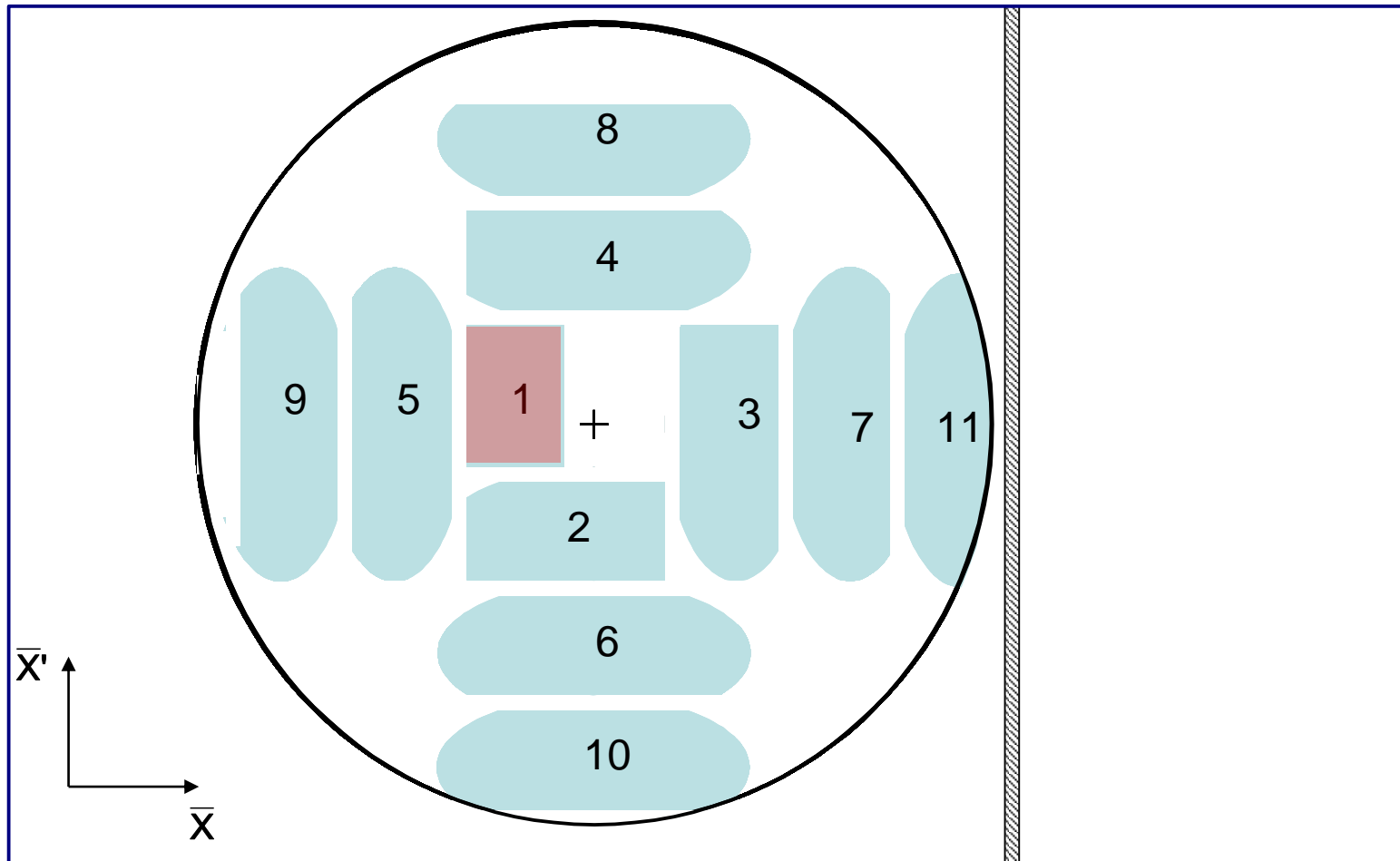

In reality, filamentation (often space-charge driven) occurs to produce a quasi-uniform beam

Charge exchange H⁻ injection

- Multi-turn injection is essential to accumulate high intensity
- Disadvantages inherent in using an injection septum:
 - Width of several mm reduces aperture
 - Beam losses from circulating beam hitting septum:
 - typically 30 – 40 % for the CERN PSB injection at 50 MeV
 - Limits number of injected turns to 10 – 20
- **Charge-exchange injection** provides elegant alternative
 - Possible to “cheat” Liouville’s theorem, which says that emittance is conserved....
 - Convert H⁻ to p⁺ using a thin stripping foil, allowing injection [into the same phase space area](#)

Charge exchange H- injection

Start of injection process

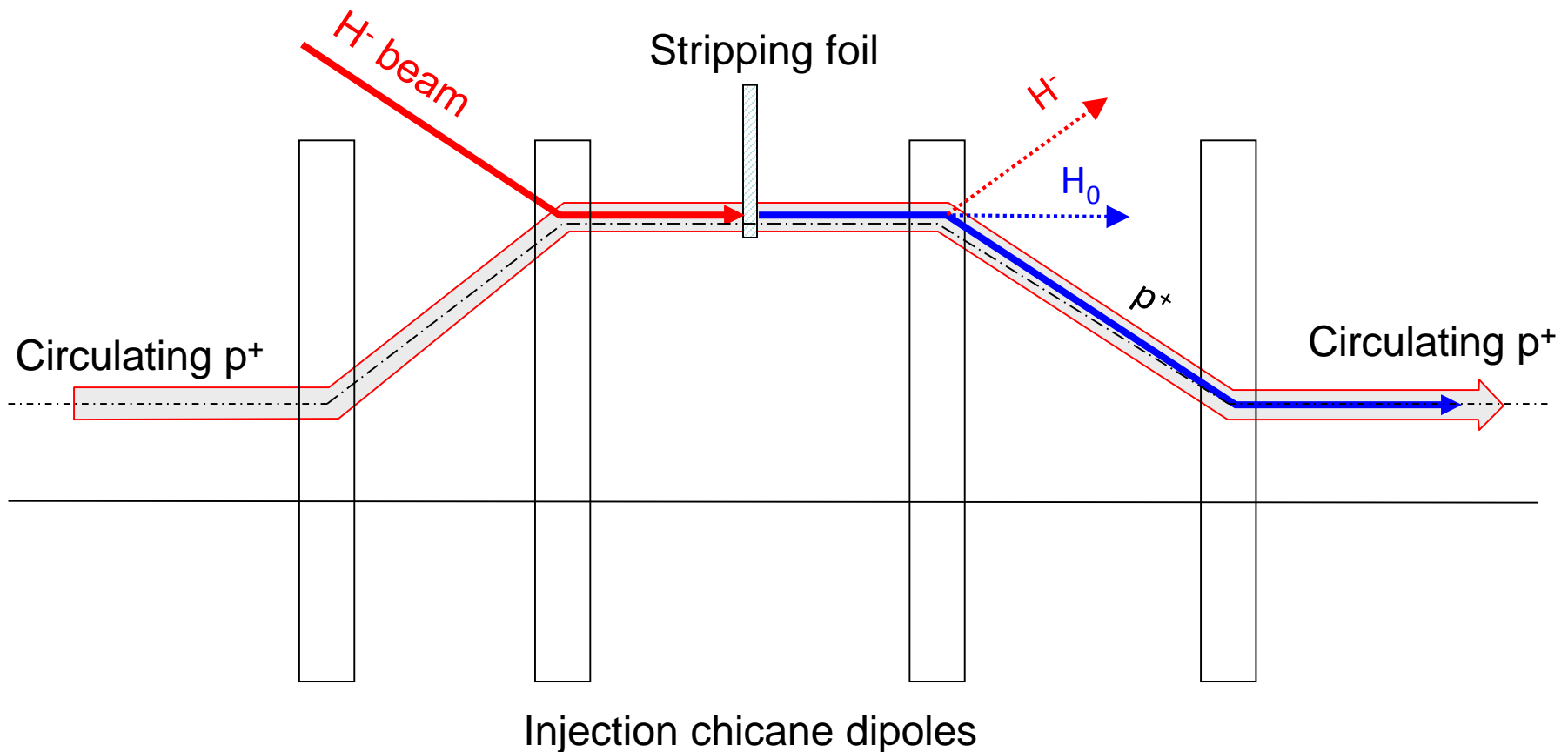

Charge exchange H- injection

End of injection process with painting

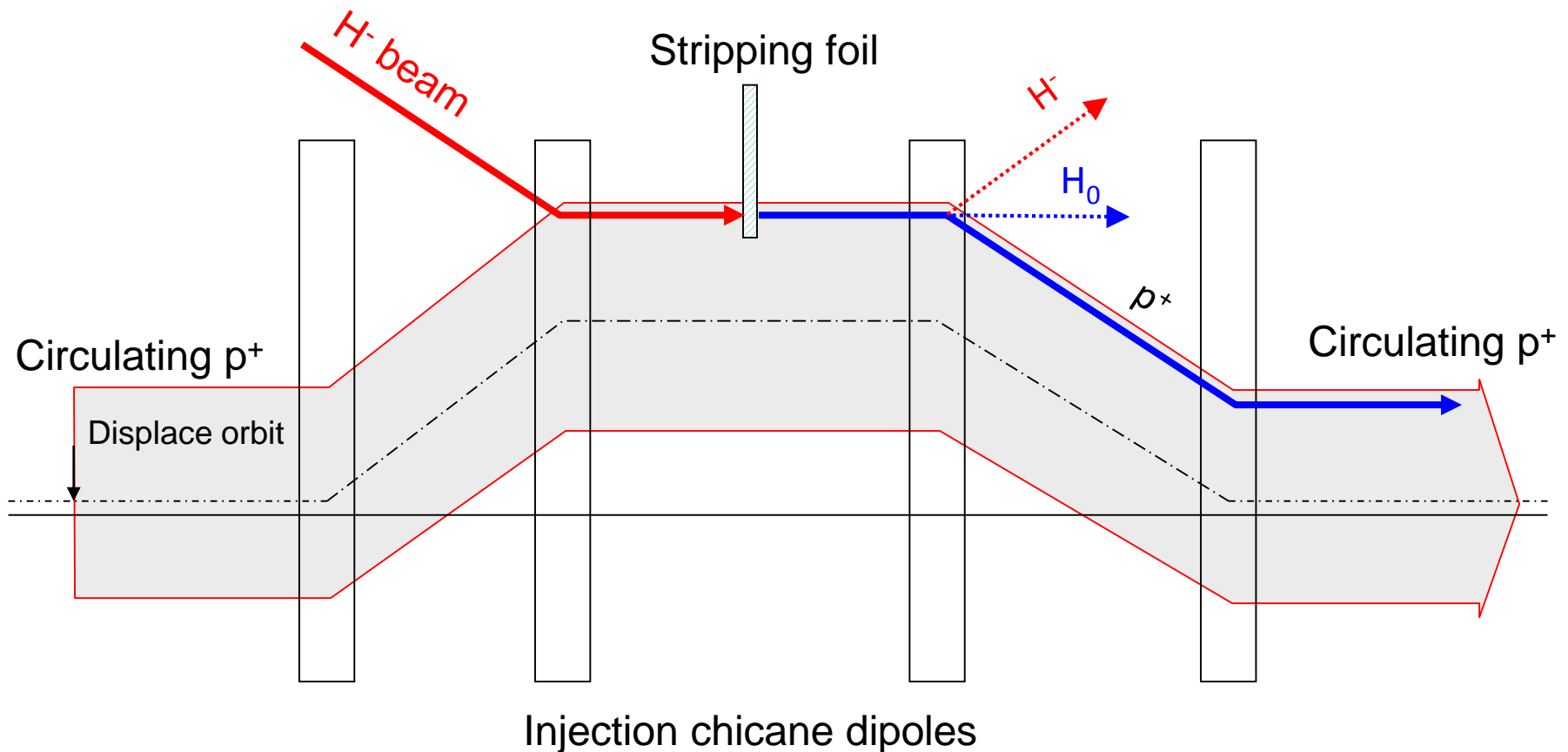

Accumulation process on foil

- Linac4 connection to the PS booster at 160 MeV:
 - H⁻ stripped to p⁺ with an estimated efficiency $\approx 98\%$ with C foil $200 \mu\text{g}\cdot\text{cm}^{-2}$

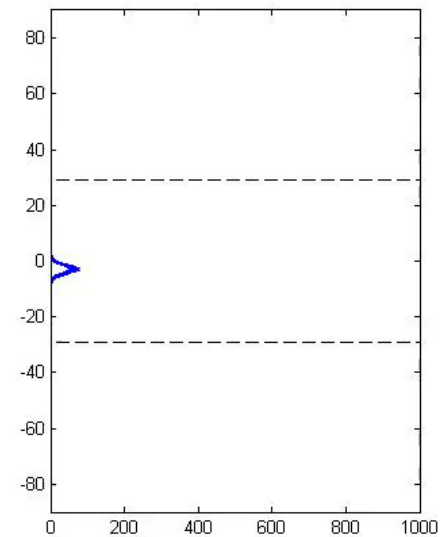
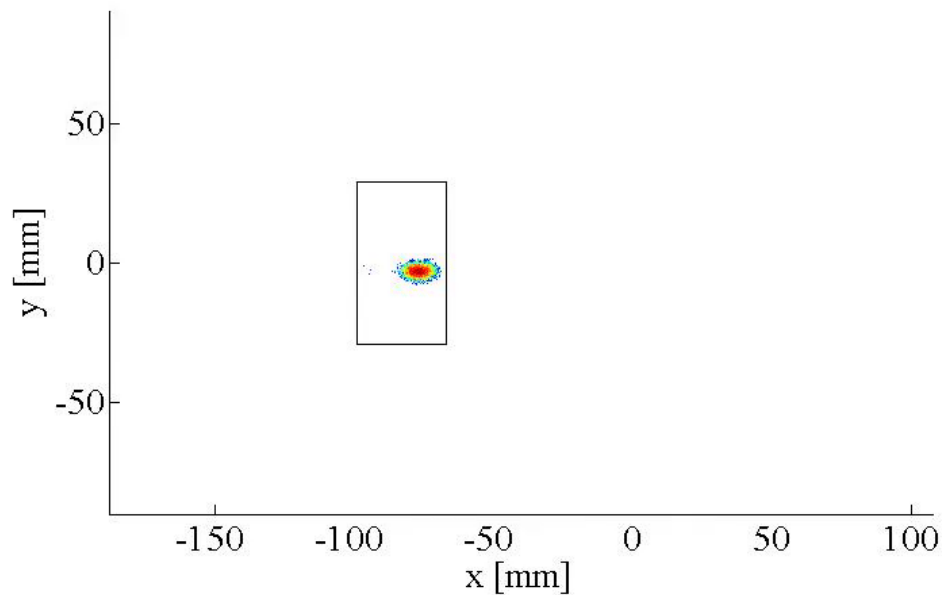
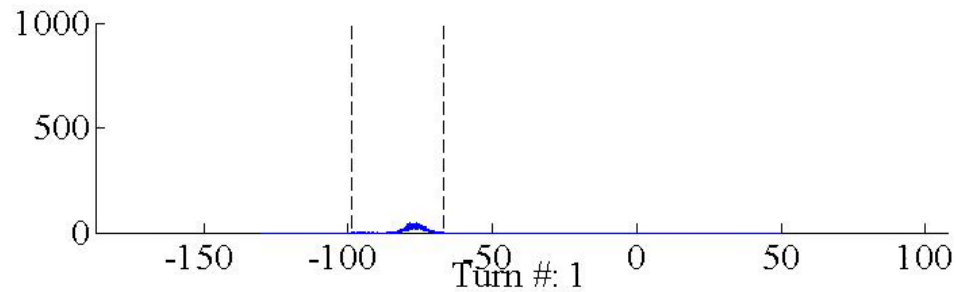

Charge exchange H- injection

- Paint uniform transverse phase space density by modifying closed orbit bump and steering injected beam
- Foil thickness calculated to double-strip most ions ($\approx 99\%$)
 - 50 MeV – $50 \mu\text{g}\cdot\text{cm}^{-2}$
 - 800 MeV – $200 \mu\text{g}\cdot\text{cm}^{-2}$ ($\approx 1 \mu\text{m}$ of C!)
- Carbon foils generally used – very fragile
- Injection chicane reduced or switched off after injection, to avoid excessive foil heating and beam blow-up
- Longitudinal phase space can also be painted turn-by-turn:
 - Variation of the injected beam energy turn-by-turn (linac voltage scaled)
 - Chopper system in linac to match length of injected batch to bucket

H- injection - painting

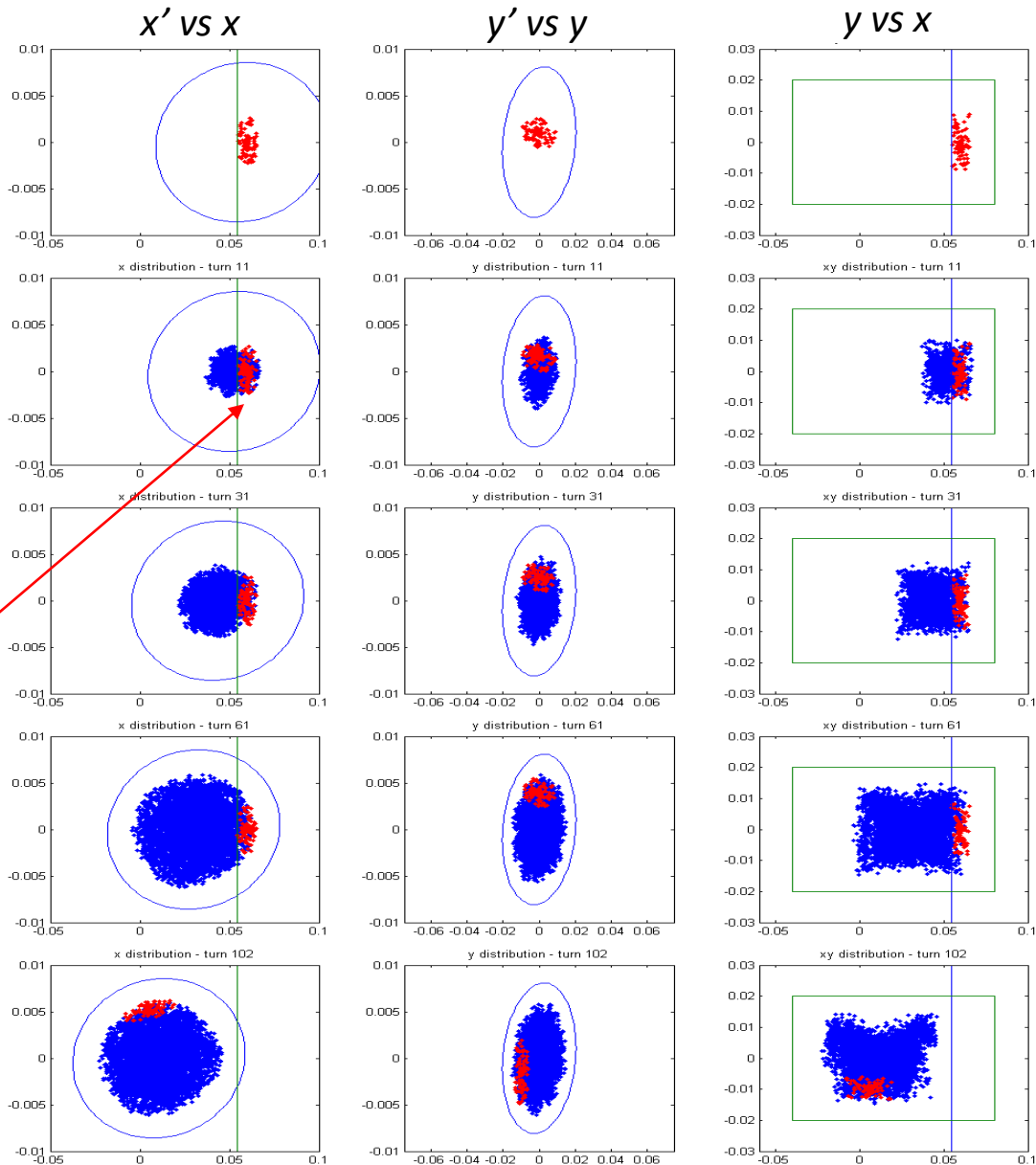

Note injection into same phase space area as circulating beam

Lepton injection

- Single-turn injection can be used as for hadrons; however, lepton motion is strongly damped (different with respect to proton or ion injection).
 - Synchrotron radiation
 - see *Electron Beam Dynamics lectures by L. Rivkin*
- Can use transverse or longitudinal damping:
 - Transverse - Betatron accumulation
 - Longitudinal - Synchrotron accumulation (2 x faster than transverse)

Betatron lepton injection

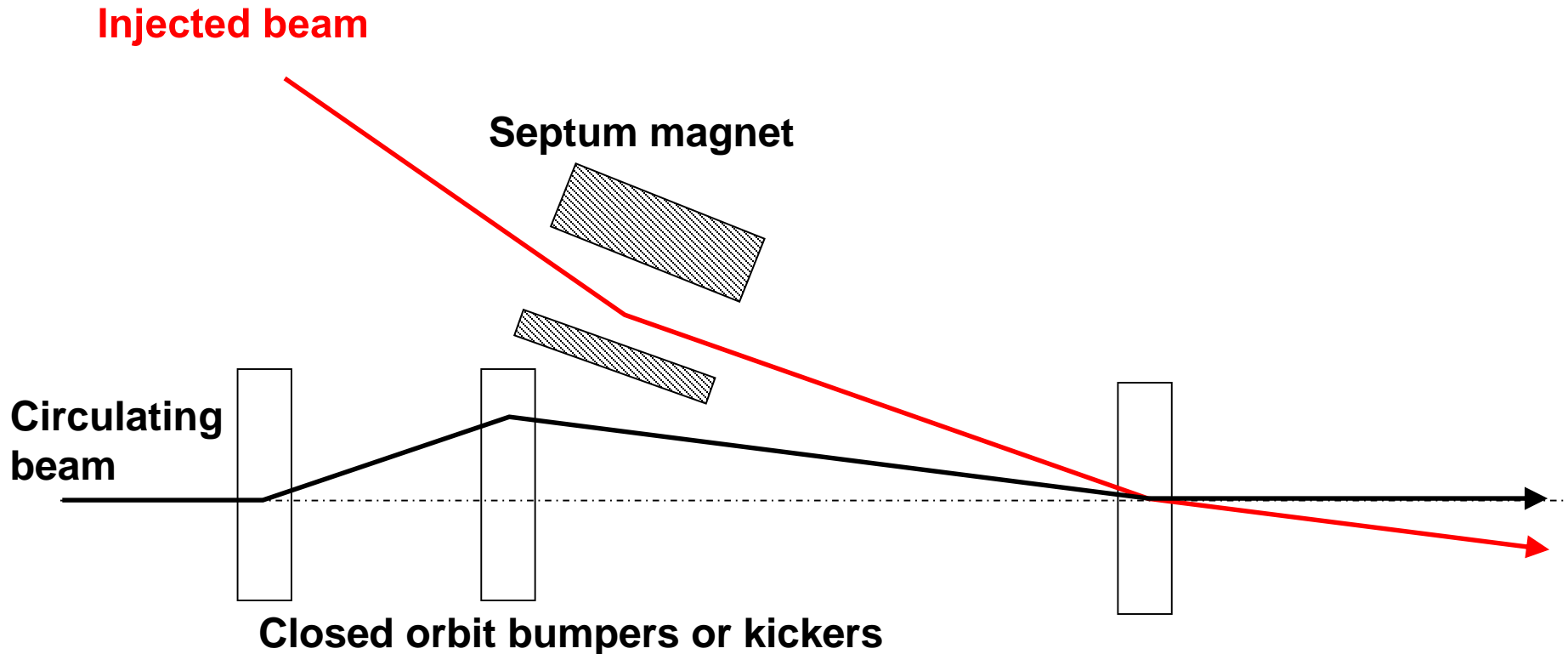

- Beam is injected with an angle with respect to the closed orbit
- Injected beam performs damped betatron oscillations about the closed orbit

Betatron lepton injection

Injected bunch performs damped betatron oscillations

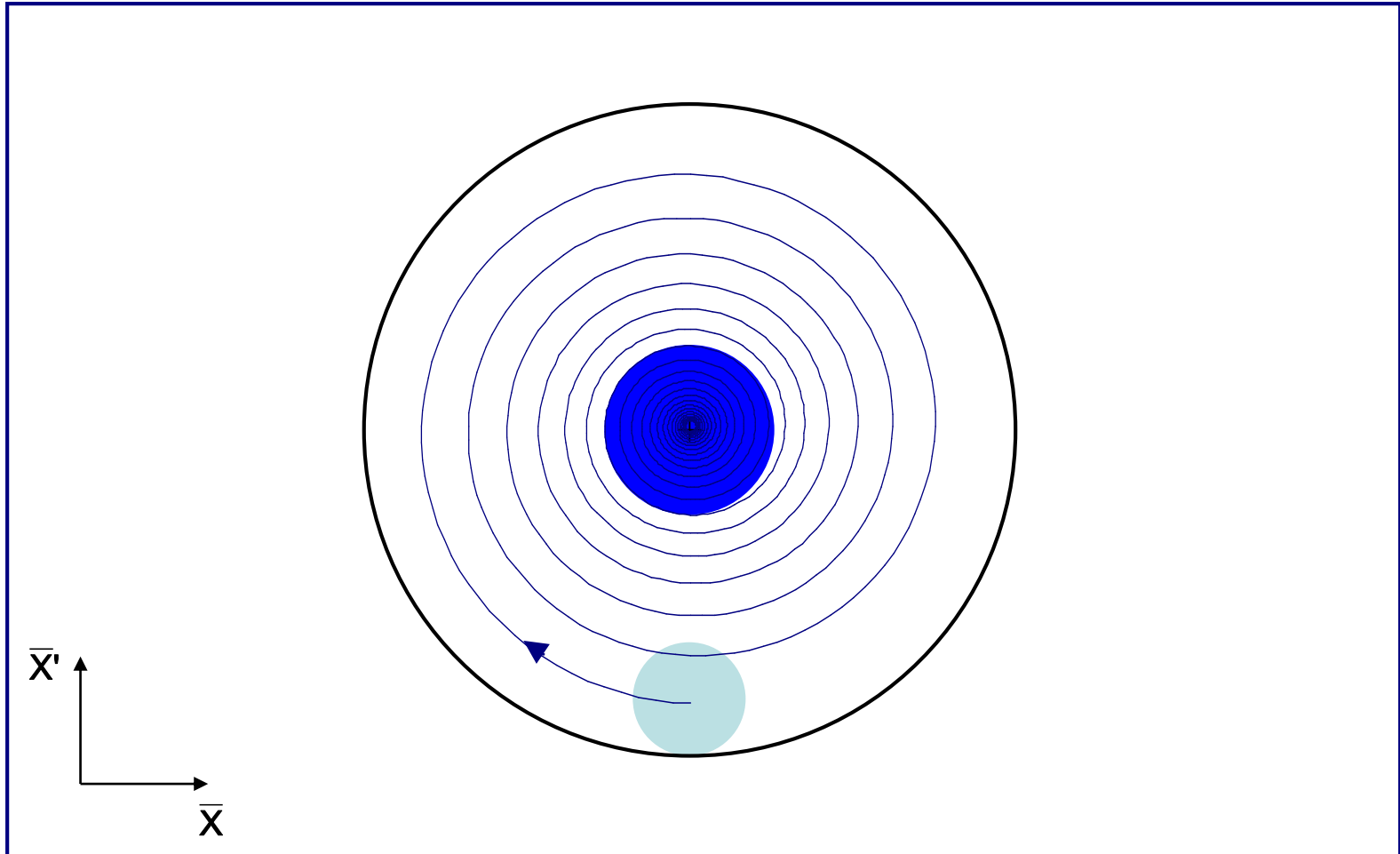

In LEP at 20 GeV, the damping time was about 6'000 turns (0.6 seconds)

Synchrotron lepton injection

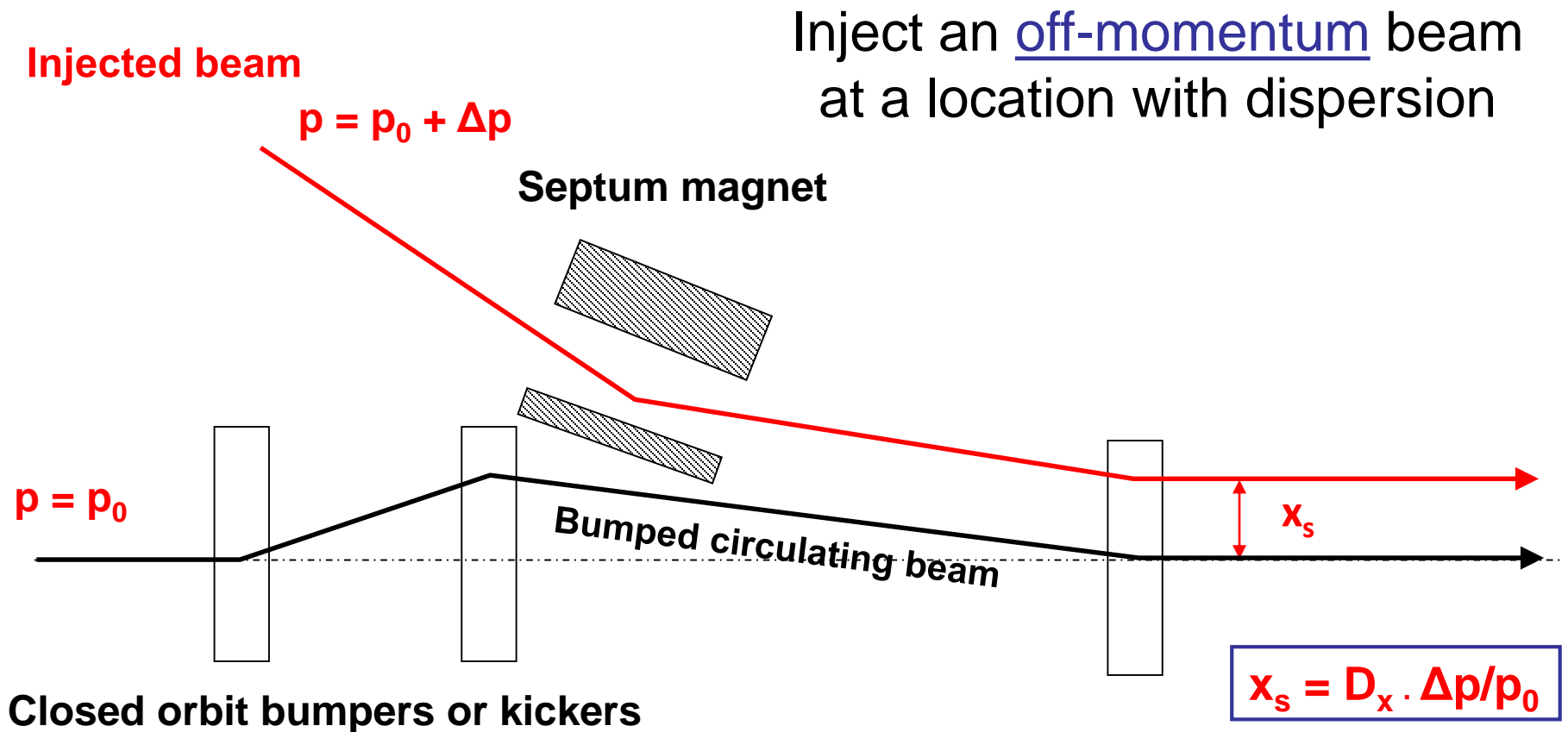

- Beam injected parallel to circulating beam, onto dispersion orbit of a particle having the same momentum offset $\Delta p/p$
- Injected beam makes damped synchrotron oscillations at Q_s but does not perform betatron oscillations

Synchrotron lepton injection

Double batch injection possible....

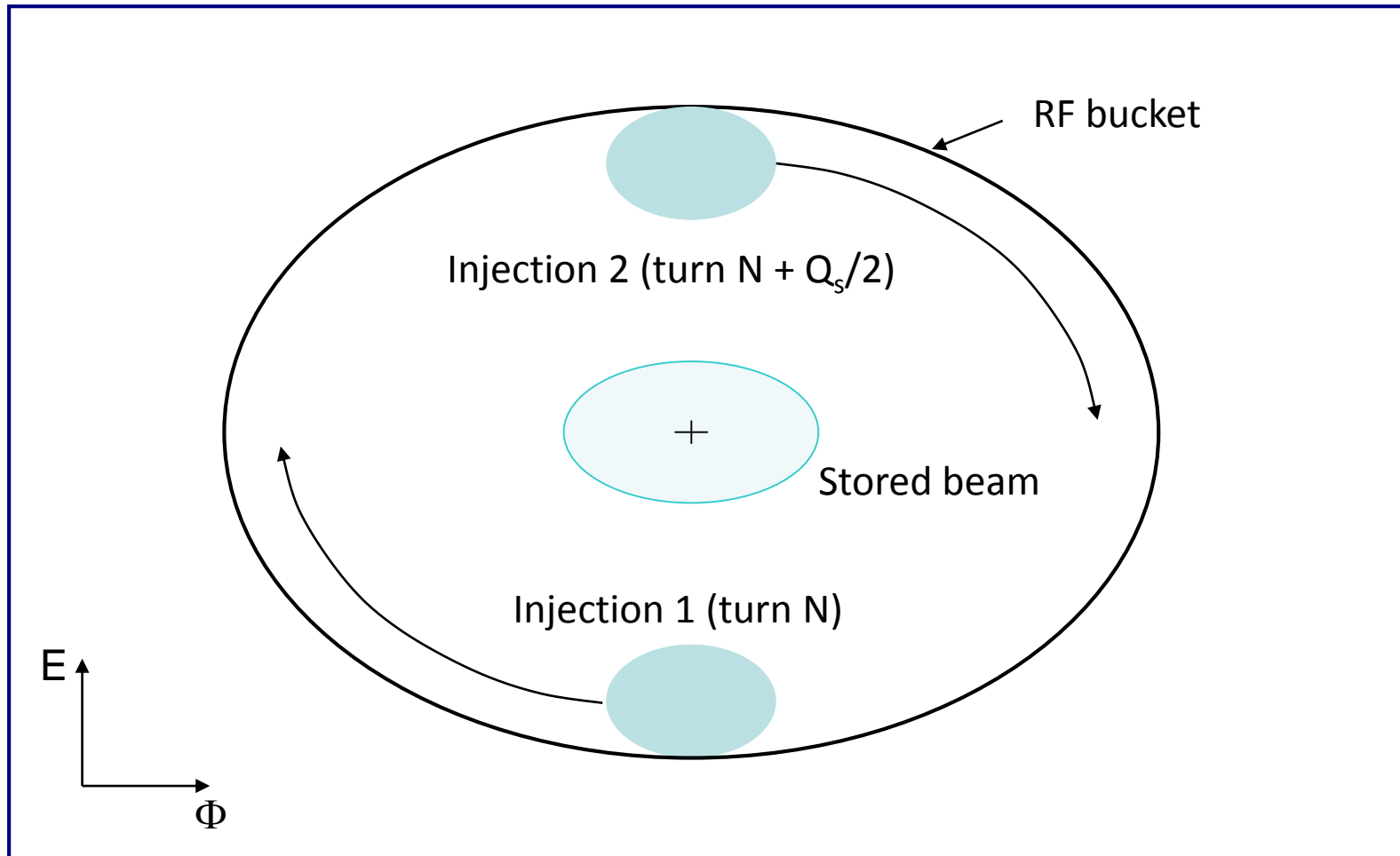

Longitudinal damping time in LEP was $\sim 3'000$ turns (2x faster than transverse)

Synchrotron lepton injection in LEP

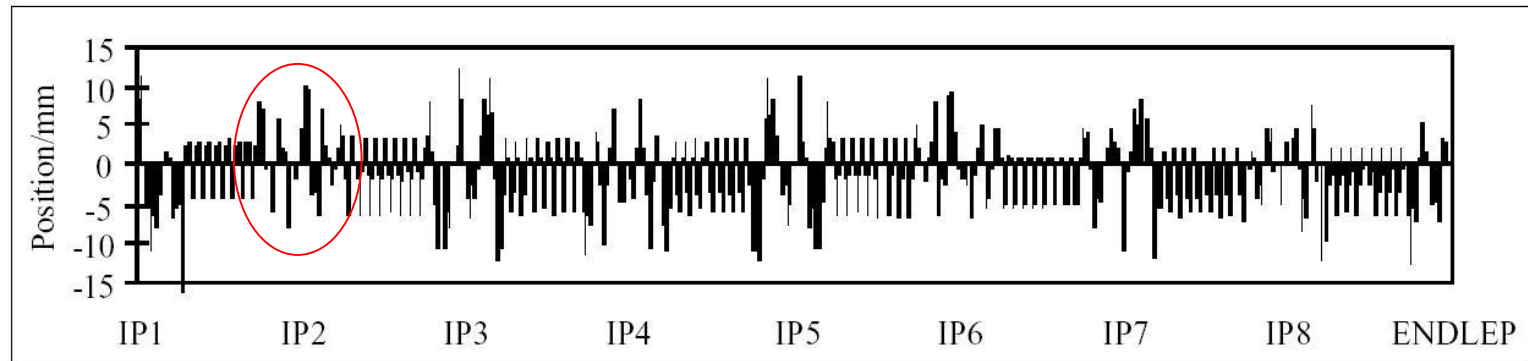

Optimized Horizontal First Turn Trajectory for Betatron Injection of Positrons into LEP.

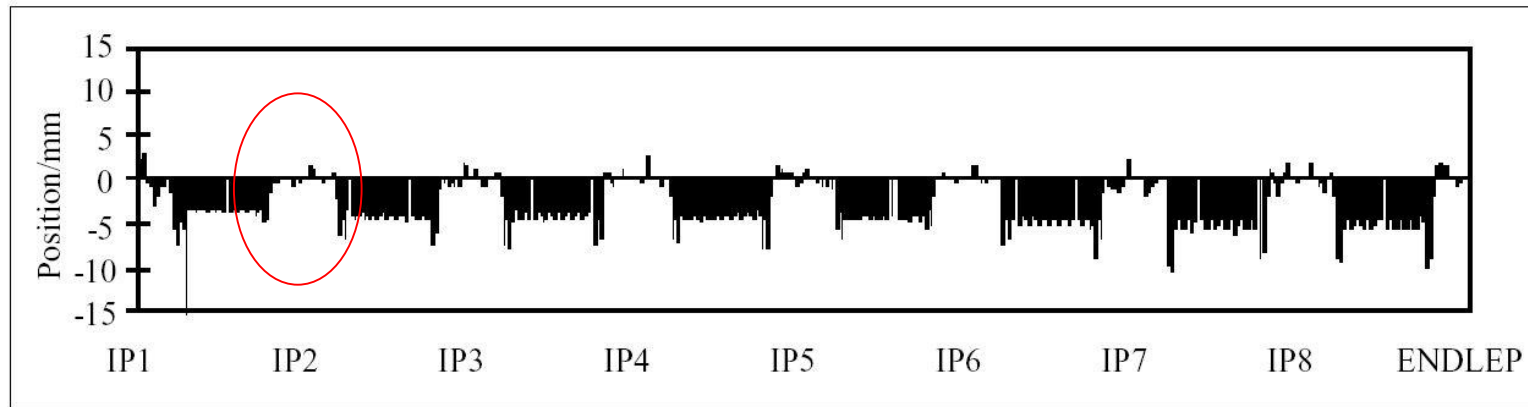

Optimized Horizontal First Turn Trajectory for Synchrotron Injection of Positrons with $\Delta P/P$ at -0.6%

Synchrotron injection in LEP gave improved background for LEP experiments due to small orbit offsets in zero dispersion straight sections

Injection - summary

- Several different techniques using kickers, septa and bumpers:
 - **Single-turn injection** for hadrons
 - Boxcar stacking: transfer between machines in accelerator chain
 - Angle / position errors \Rightarrow injection oscillations
 - Uncorrected errors \Rightarrow filamentation \Rightarrow emittance increase
 - **Multi-turn injection** for hadrons
 - Phase space painting to increase intensity
 - H- injection allows injection into same phase space area
 - **Lepton injection**: take advantage of damping
 - Less concerned about injection precision and matching

Extraction

- Different extraction techniques exist, depending on requirements
 - **Fast extraction:** ≤ 1 turn
 - **Non-resonant (fast) multi-turn extraction:** few turns
 - **Resonant low-loss (fast) multi-turn extraction:** few turns
 - **Resonant multi-turn extraction:** many thousands of turns
- Usually higher energy than injection \Rightarrow stronger elements ($\int B \cdot dl$)
 - At high energies many kicker and septum modules may be required
 - To reduce kicker and septum strength, beam can be moved near to septum by closed orbit bump
 - Beam size scales with $1/\sqrt{\gamma}$ \Rightarrow smaller than injection

Fast single turn extraction

Entire beam kicked into septum gap and extracted over a single turn

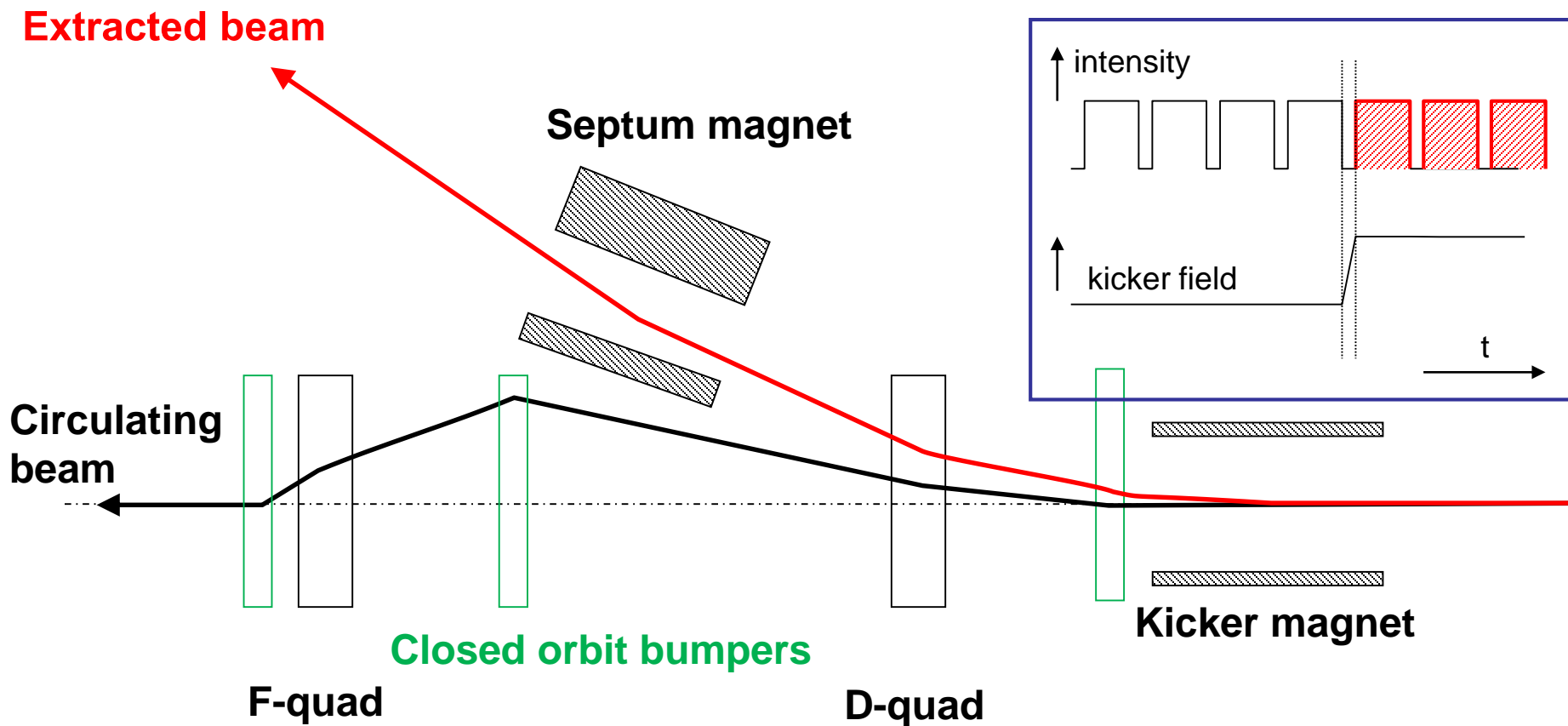

- Bumpers move circulating beam close to septum to reduce kicker strength
- Kicker deflects the entire beam into the septum in a single turn
- Most efficient (lowest deflection angles required) for $\pi/2$ phase advance between kicker and septum

Fast single turn extraction

- For transfer of beams between accelerators in an injector chain
- For secondary particle production
 - e.g. neutrinos, radioactive beams
- Losses from transverse scraping or from particles in extraction gap:
 - Fast extraction from SPS to CNGS:

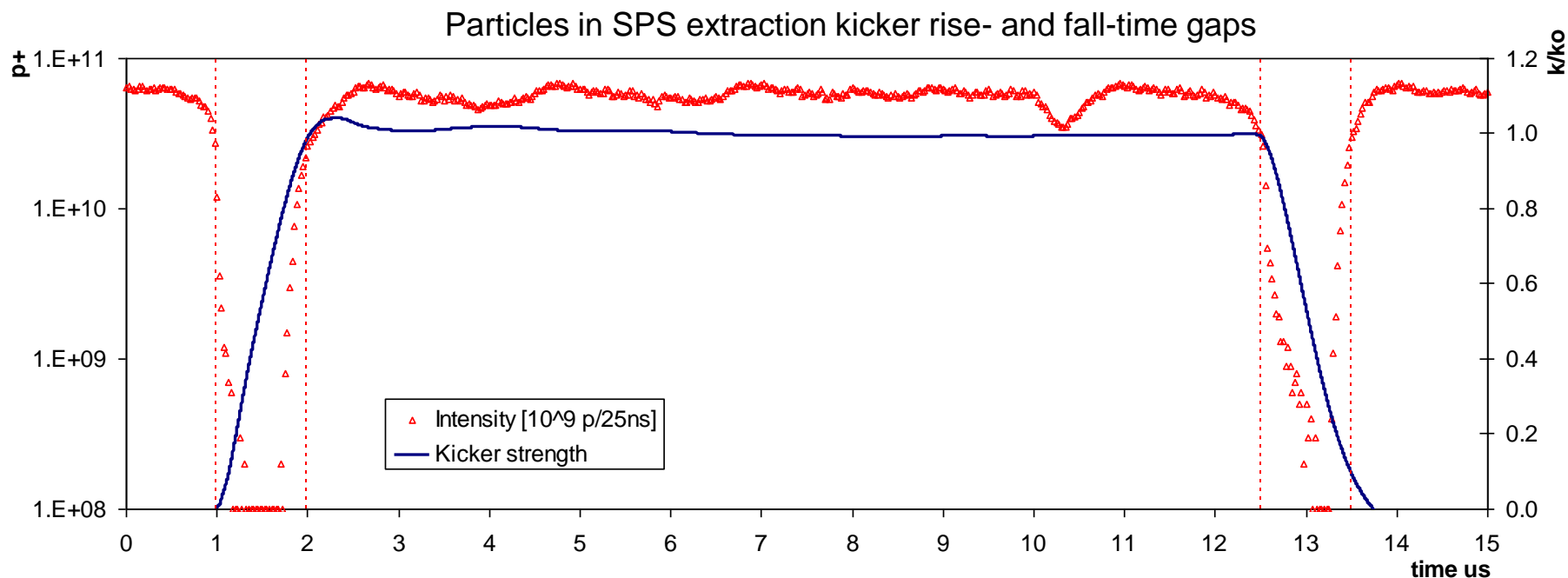

Multi-turn extraction

- Some filling schemes require a beam to be injected in several turns to a larger machine...
- And very commonly Fixed Target physics experiments and medical accelerators often need a quasi-continuous flux of particles...
- Multi-turn extraction...
 - **Fast:** Non-resonant and resonant multi-turn ejection (few turns) for filling
 - e.g. PS to SPS at CERN for high intensity proton beams ($>2.5 \cdot 10^{13}$ protons)
 - **Slow:** Resonant extraction (ms to hours) for experiments

Non-resonant multi-turn extraction

Beam bumped to septum; part of beam 'shaved' off each turn

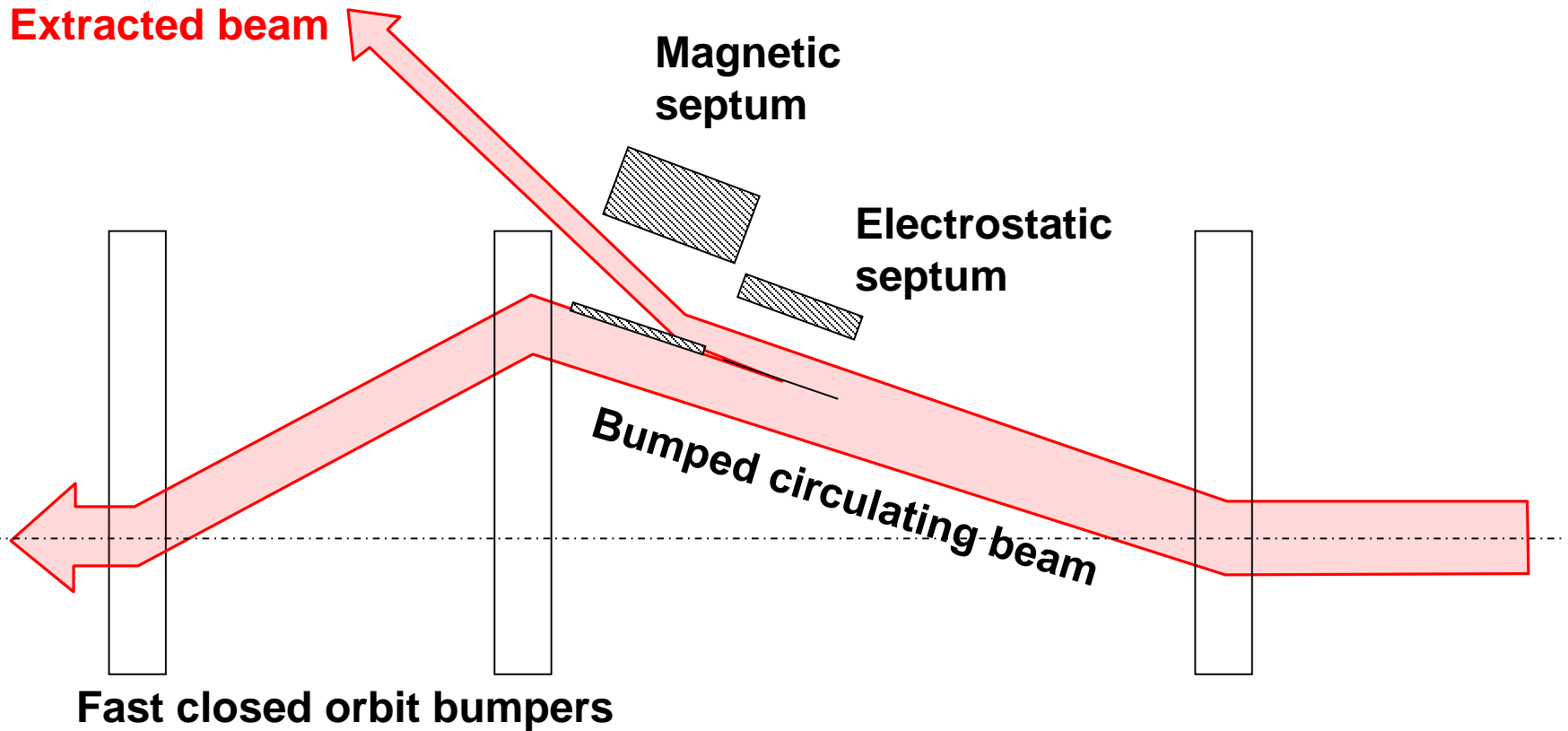

- Fast bumper deflects the whole beam onto the septum
- Beam extracted in a few turns, with the machine tune rotating the beam
- Intrinsically a high-loss process: thin septum essential
- Often combine thin electrostatic septa with magnetic septa

Non-resonant multi-turn extraction

- Example system: CERN PS to SPS Fixed-Target 'continuous transfer'.
 - Accelerate beam in PS to 14 GeV/c
 - Empty PS machine (2.1 μs long) in 5 turns into SPS
 - Do it again
 - Fill SPS machine ($11 \times C_{\text{PS}}$, 23 μs long)
 - Quasi-continuous beam in SPS (2 x 1 μs gaps)
 - Total intensity per PS extraction $\approx 3 \times 10^{13}$ p+
 - Total intensity in SPS $\approx 5 \times 10^{13}$ p+

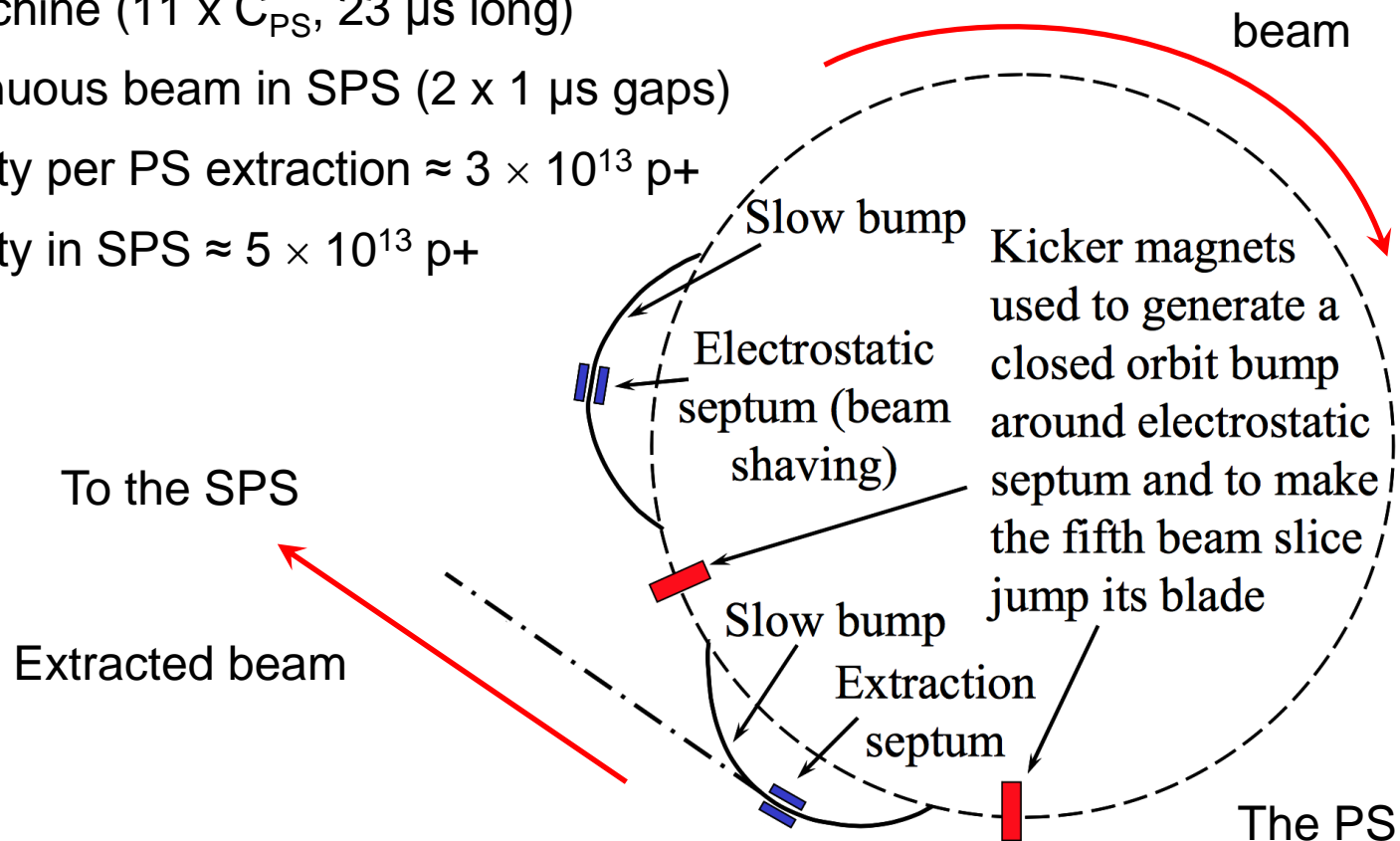

Non-resonant multi-turn extraction

CERN PS to SPS: 5-turn continuous transfer – 1st turn

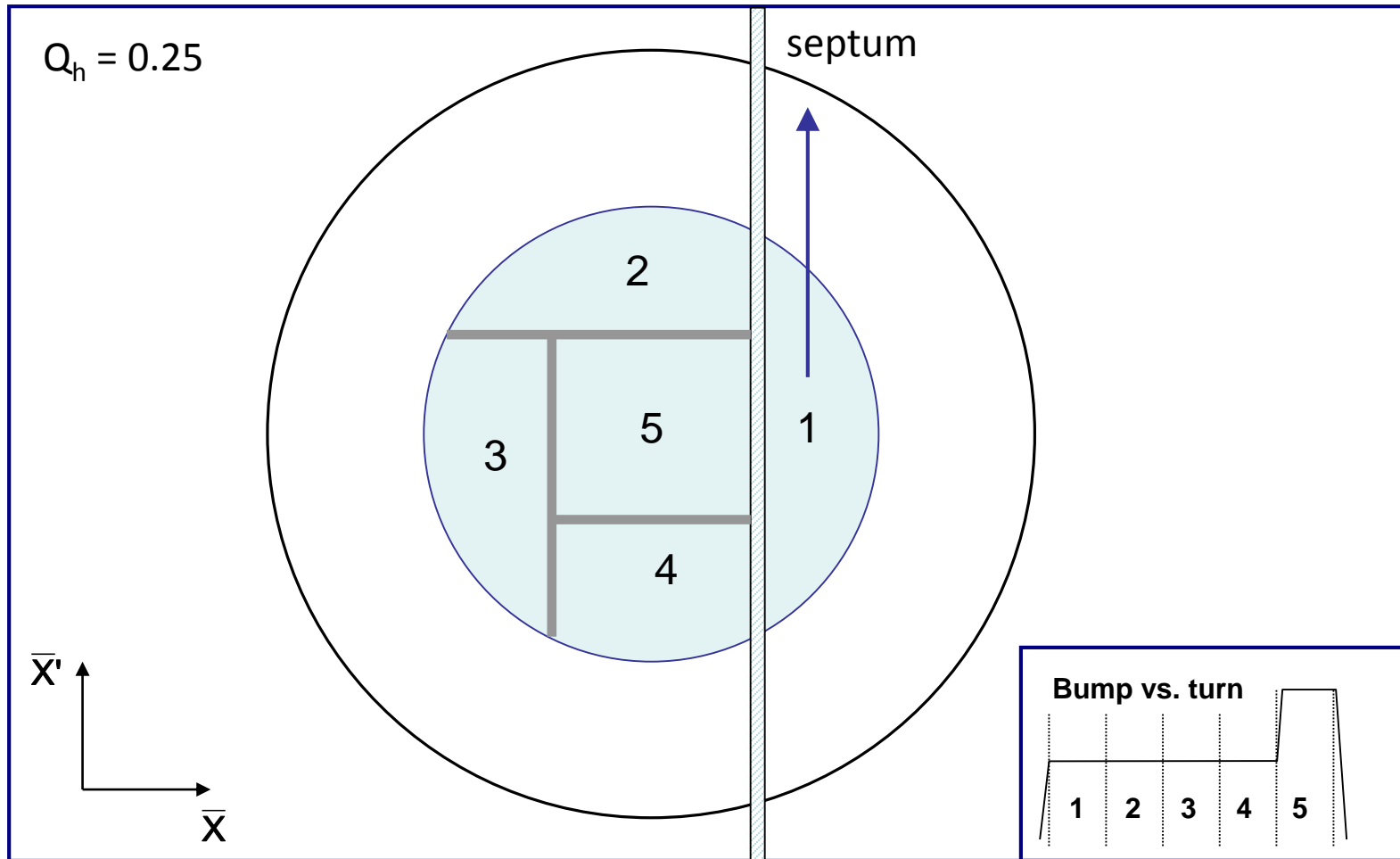

Non-resonant multi-turn extraction

CERN PS to SPS: 5-turn continuous transfer – 2nd turn

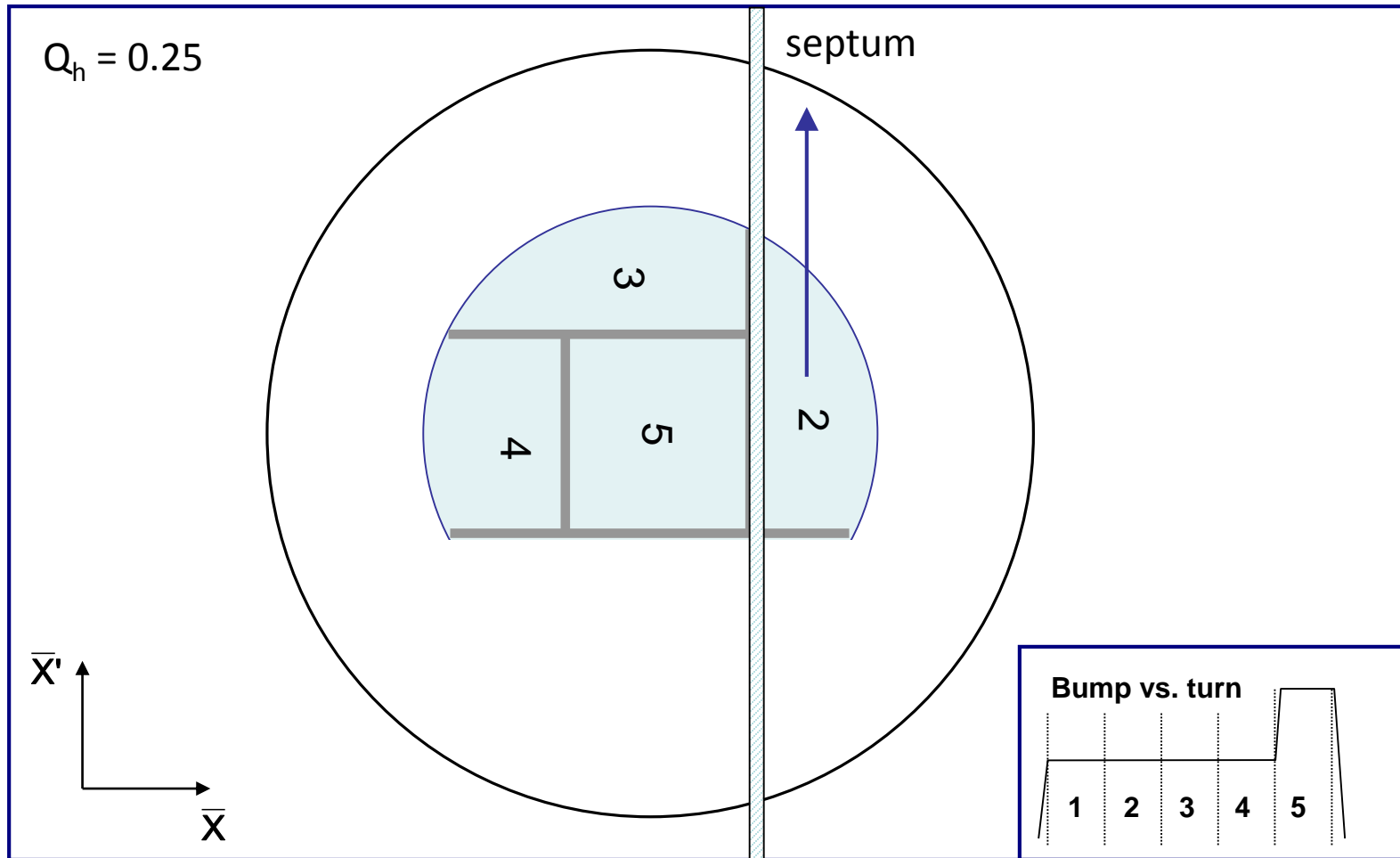

Non-resonant multi-turn extraction

CERN PS to SPS: 5-turn continuous transfer – 3rd turn

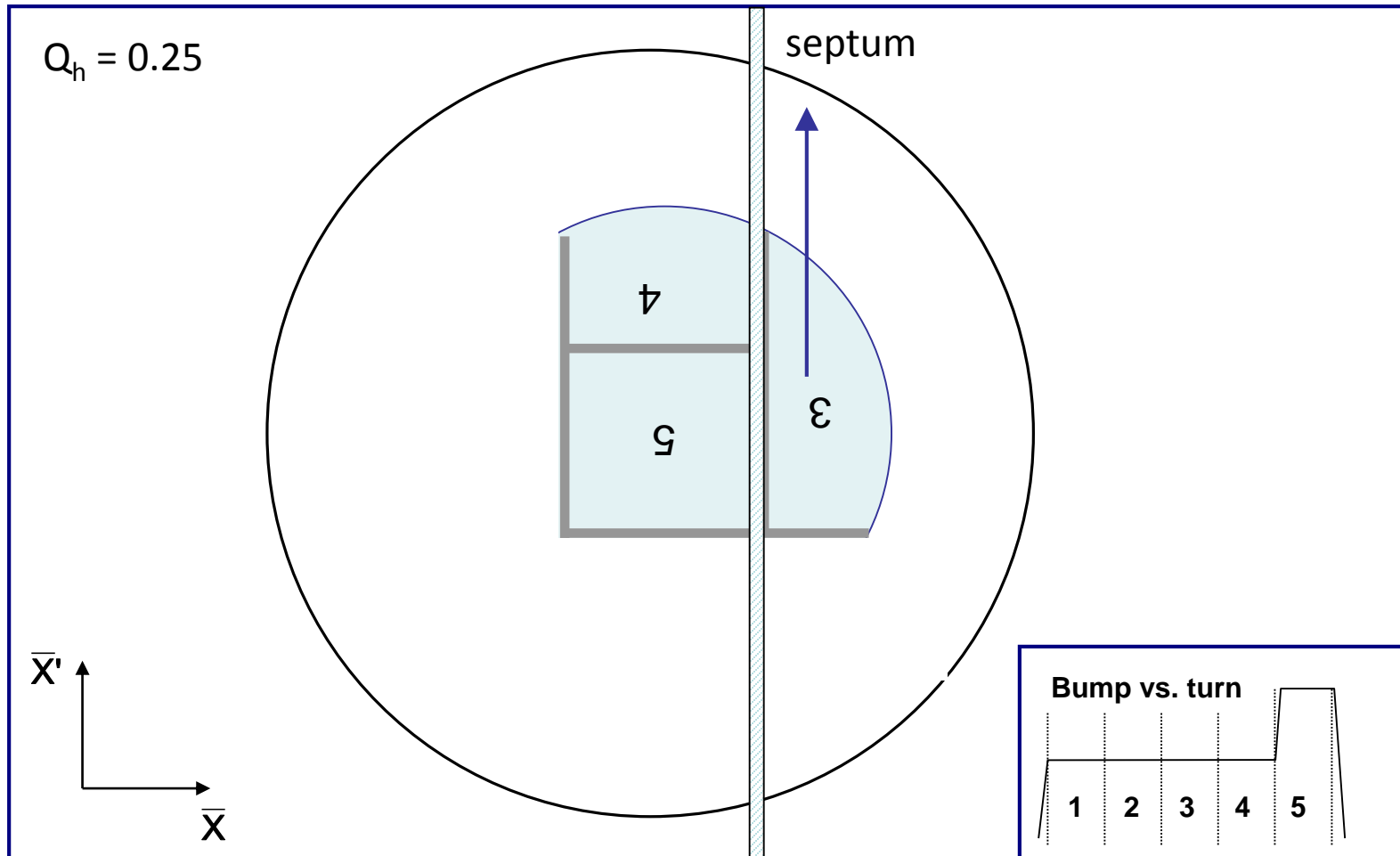

Non-resonant multi-turn extraction

CERN PS to SPS: 5-turn continuous transfer – 4th turn

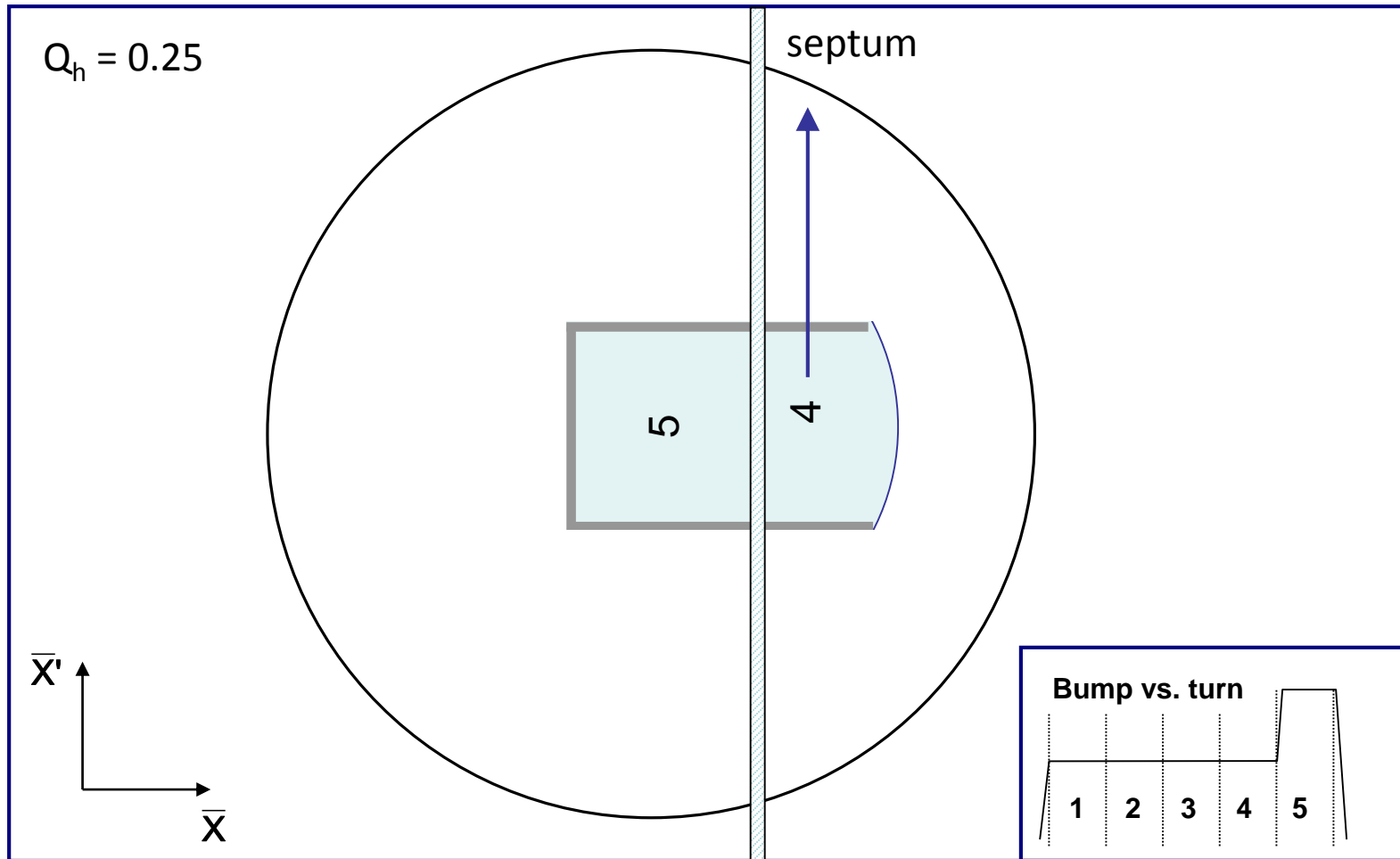

Non-resonant multi-turn extraction

CERN PS to SPS: 5-turn continuous transfer – 5th turn

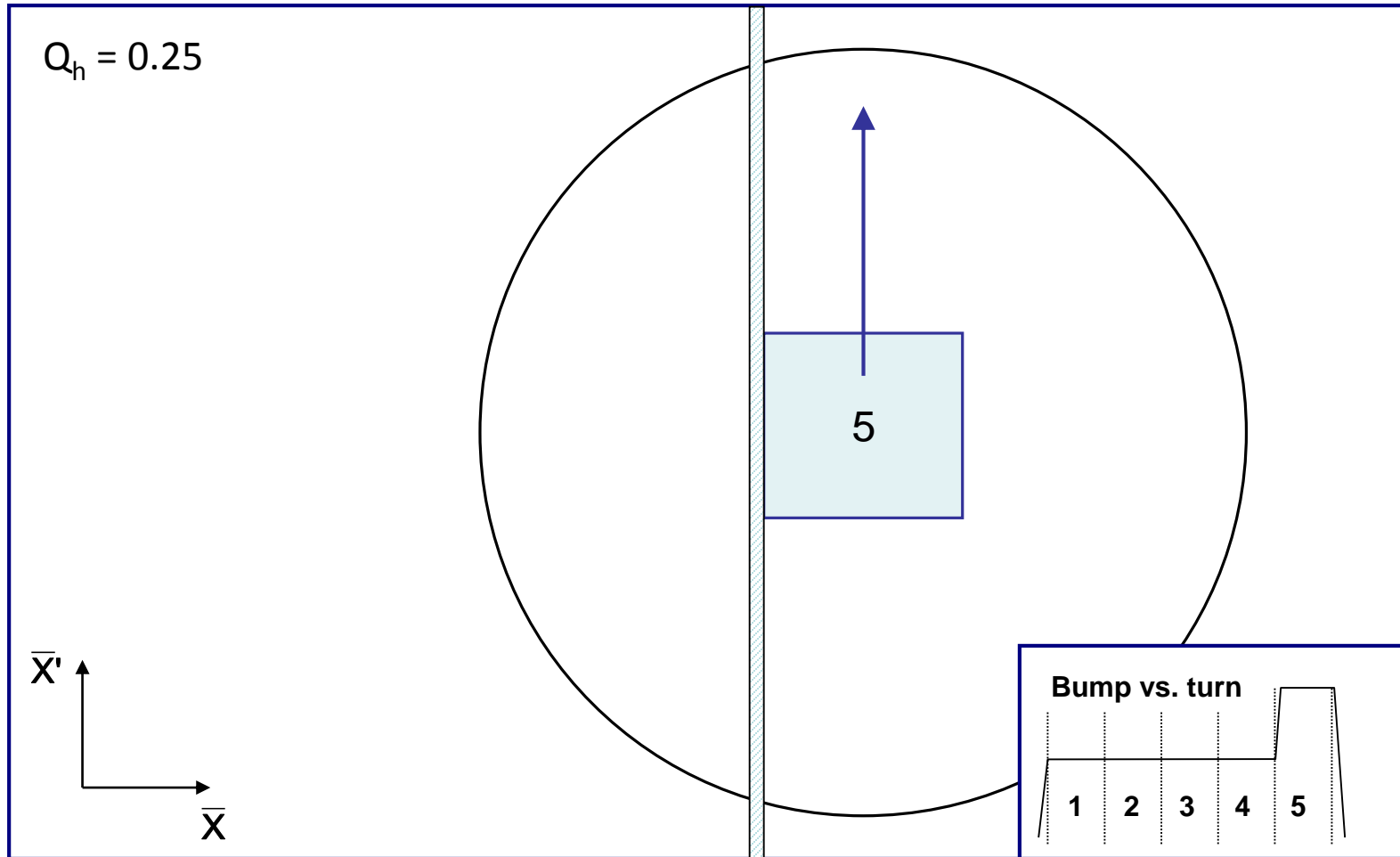

Non-resonant multi-turn extraction

- CERN PS to SPS: 5-turn continuous transfer
 - Losses impose thin septum...
 - ... an electrostatic septum is needed in addition to the magnetic septum
 - Still about 15 % of beam lost in PS-SPS CT
 - Difficult to get equal intensities per turn
 - Different trajectories for each turn
 - Different emittances for each turn

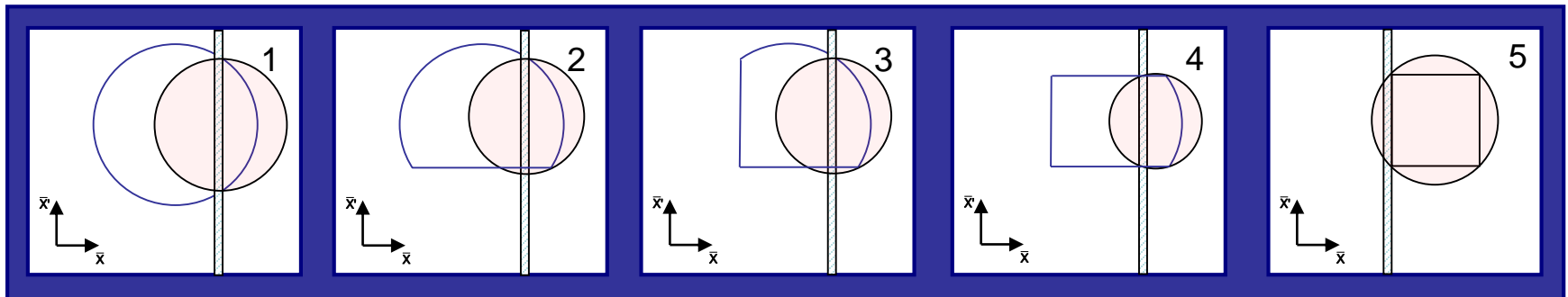
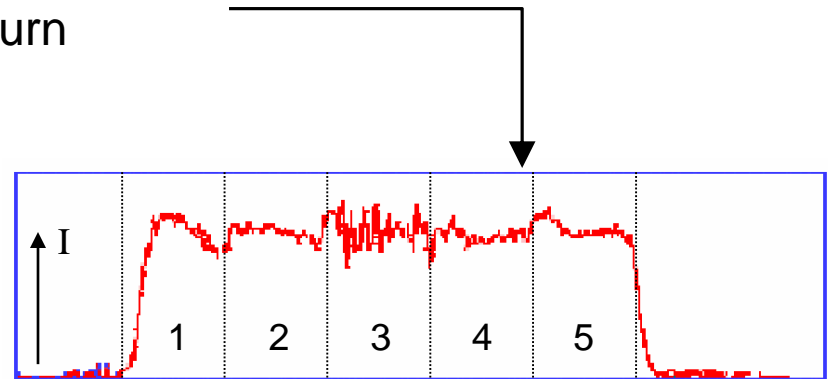

Resonant multi-turn (fast) extraction

- Adiabatic capture of beam in stable “islands”
 - Use non-linear fields (sextupoles and octupoles) to create islands of stability in phase space
 - A slow (adiabatic) tune variation to cross a resonance and to drive particles into the islands (capture) with the help of transverse excitation (using damper)
 - Variation of field strengths to separate the islands in phase space
- Several big advantages:
 - Losses reduced significantly (no particles at the septum in transverse plane)
 - Phase space matching improved with respect to existing non-resonant multi-turn extraction - ‘beamlets’ have similar emittance and optical parameters

Resonant multi-turn (fast) extraction

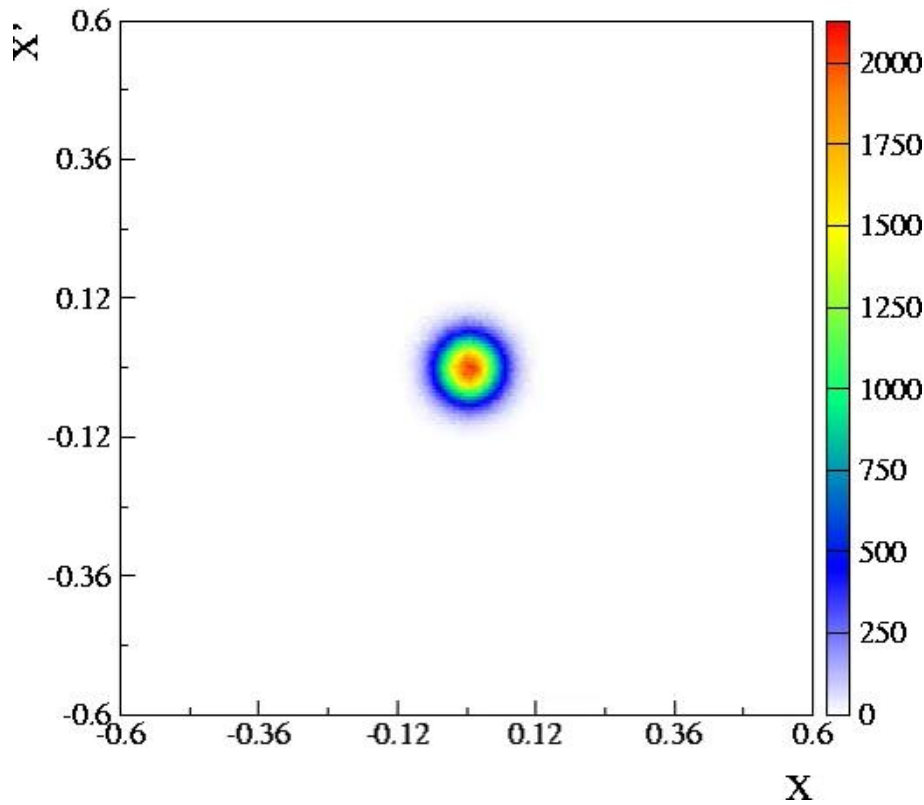
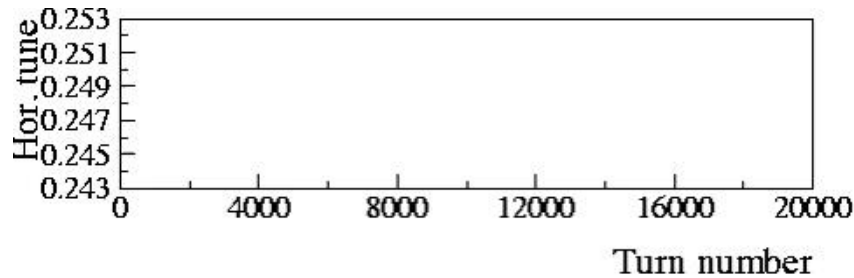

a. Unperturbed beam

b. Increasing non-linear fields

a. Beam captured in stable islands

b. Islands separated and beam bumped across septum – extracted in 5 turns

(see *Non-Linear Beam Dynamics lectures* by Y. Papaphilippou)

Resonant multi-turn (fast) extraction

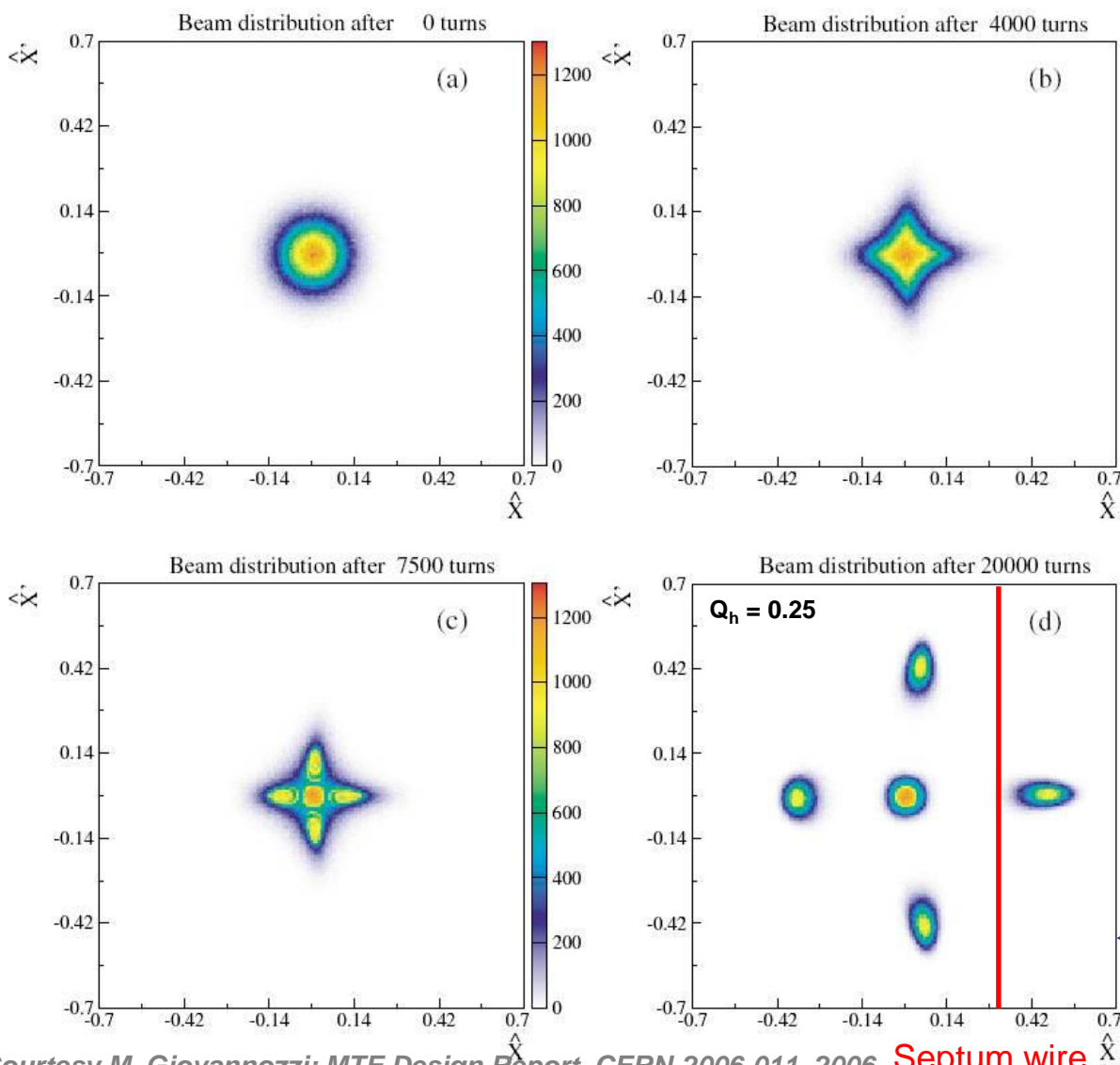

- a. Unperturbed beam
- b. Increasing non-linear fields
- a. Beam captured in stable islands
- b. Islands separated and beam bumped across septum – extracted in 5 turns

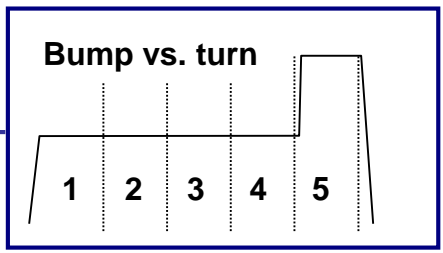

Resonant multi-turn (slow) extraction

Non-linear fields excite resonances that drive the beam slowly across the septum

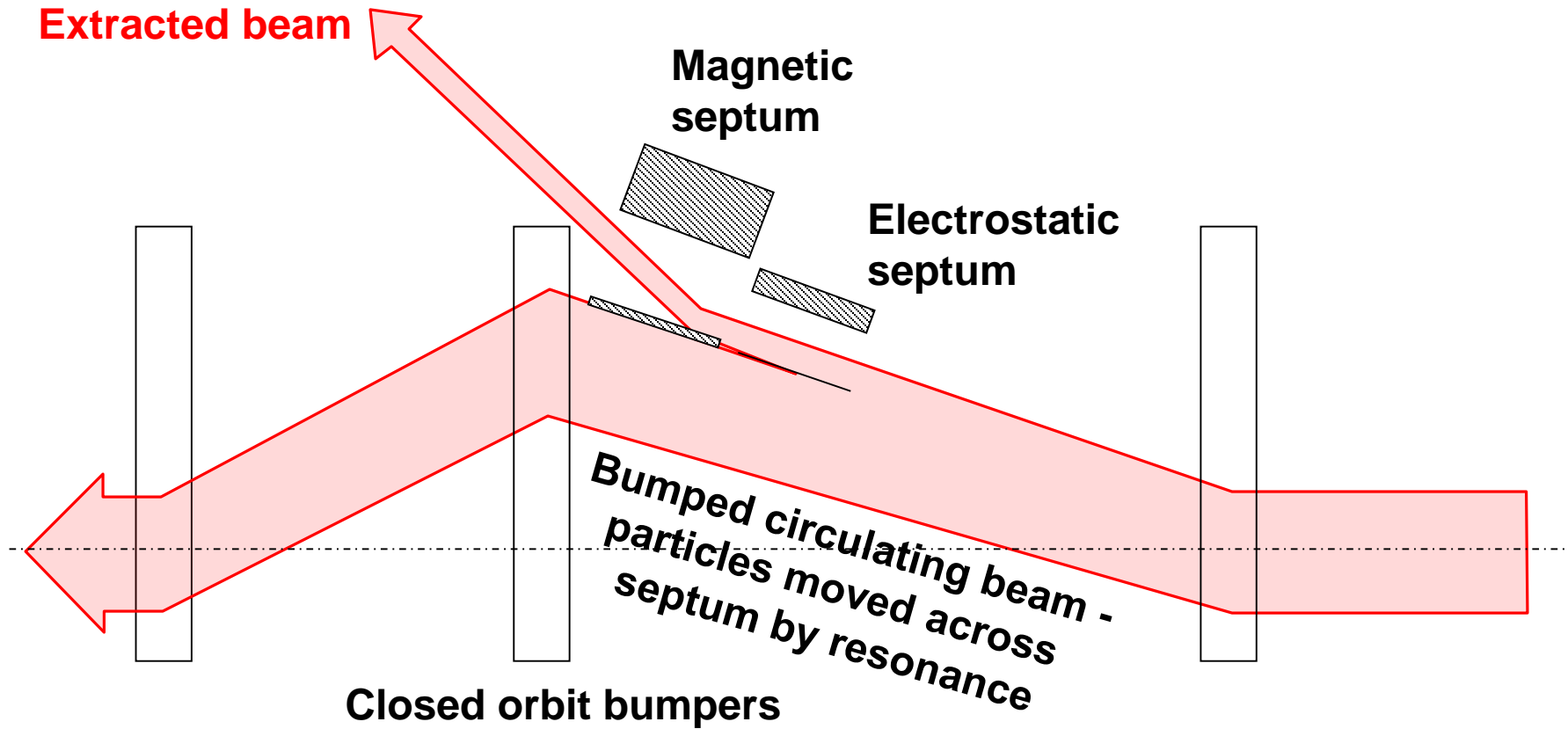

Closed orbit bumpers

- Slow bumpers move the beam near the septum
- Tune adjusted close to n^{th} order betatron resonance
- Multipole magnets excited to define stable area in phase space, size depends on $\Delta Q = Q - Q_r$

Resonant multi-turn (slow) extraction

- 3rd order resonances – see *lectures by Y. Papaphilippou*
 - Sextupole fields distort the circular normalised phase space particle trajectories.
 - Stable area defined, delimited by unstable Fixed Points.

$$R_{fp}^{1/2} \propto \Delta Q \cdot \frac{1}{k_2}$$

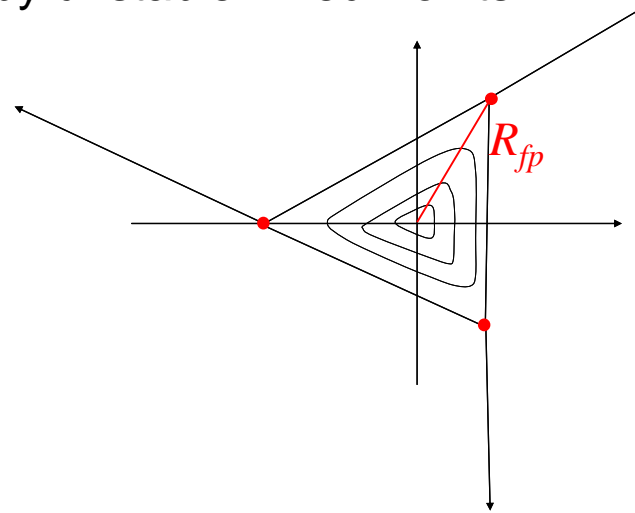

- Sextupole magnets arranged to produce suitable phase space orientation of the stable triangle at thin electrostatic septum
- Stable area can be reduced by...
 - Increasing the sextupole strength, or...
 - Fixing the sextupole strength and scanning the machine tune Q_h (and therefore the resonance) through the tune spread of the beam
 - Large tune spread created with RF gymnastics (large momentum spread) and large chromaticity

Third-order resonant extraction

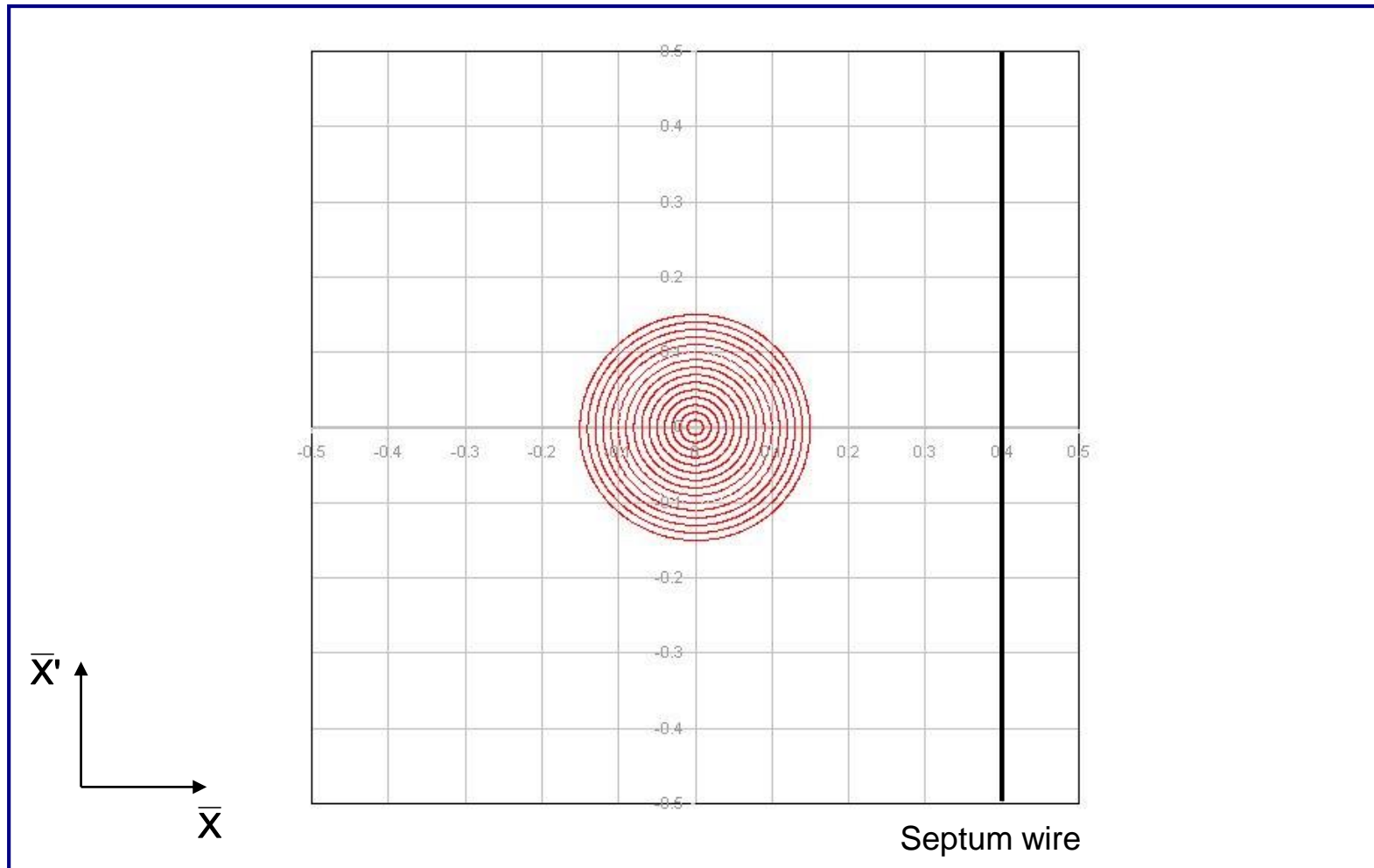

- Particles distributed on emittance contours
- ΔQ large – no phase space distortion

Third-order resonant extraction

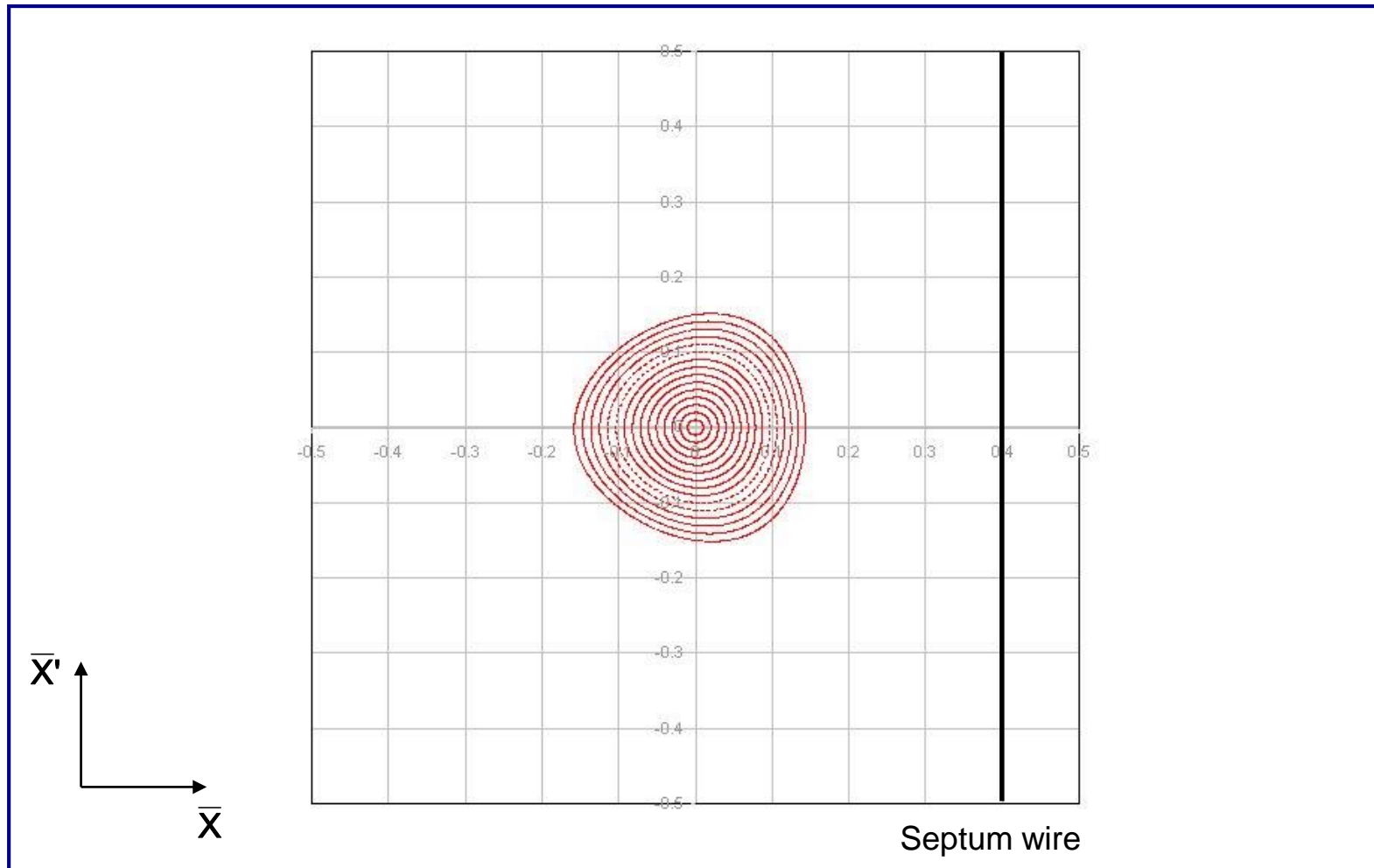

- Sextupole magnets produce a triangular stable area in phase space
- ΔQ decreasing – phase space distortion for largest amplitudes

Third-order resonant extraction

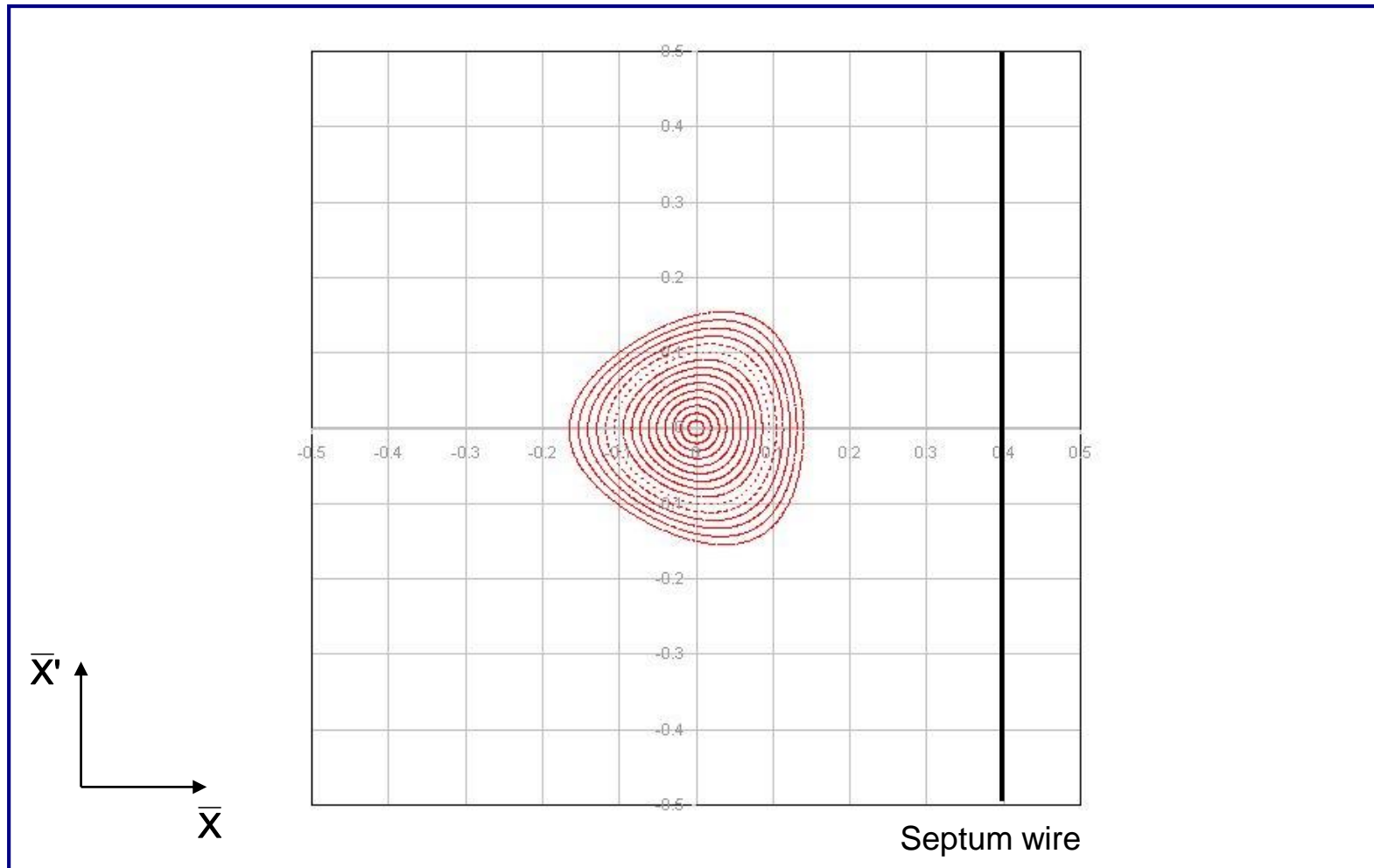

- Sextupole magnets produce a triangular stable area in phase space
- ΔQ decreasing – phase space distortion for largest amplitudes

Third-order resonant extraction

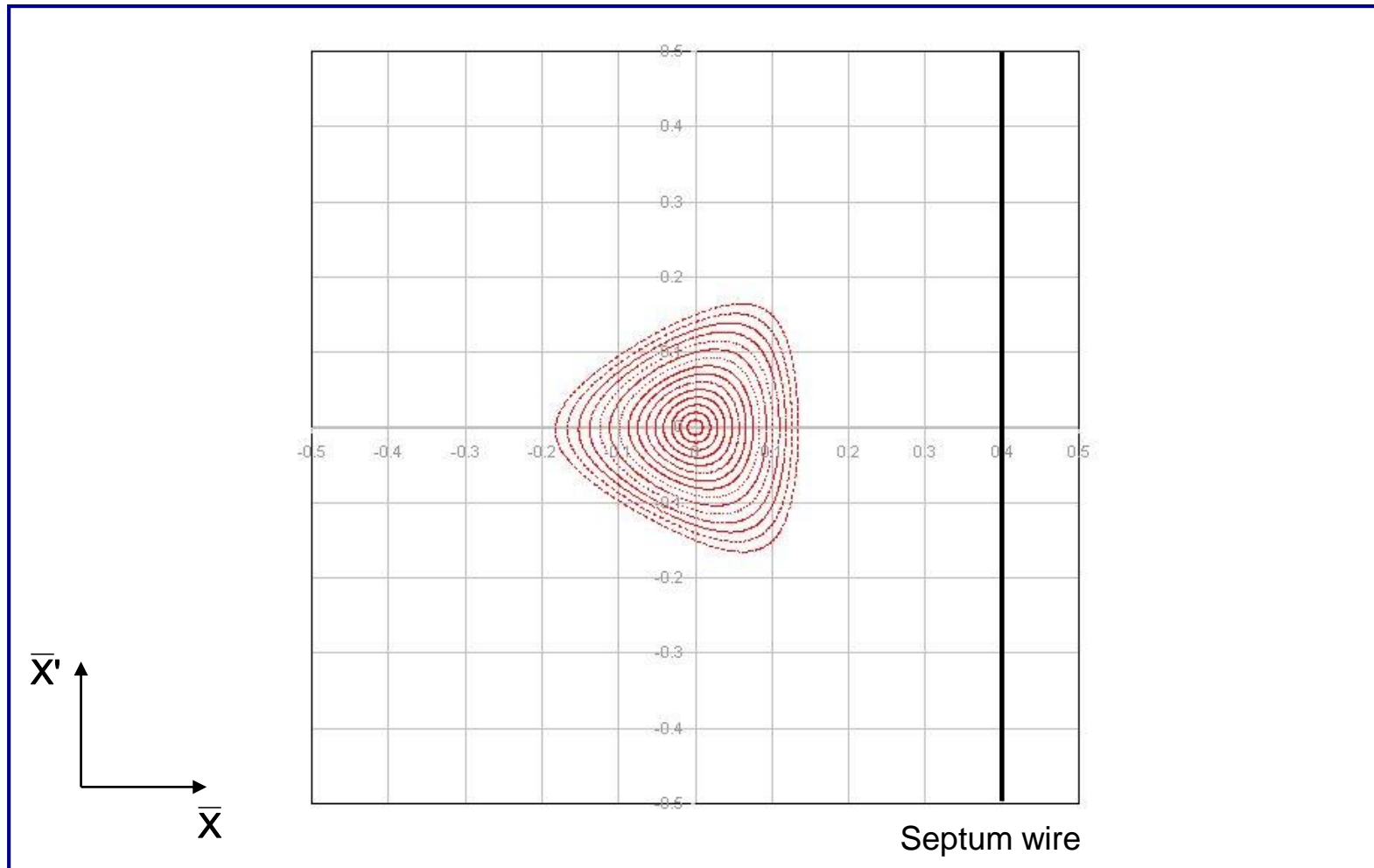

- Sextupole magnets produce a triangular stable area in phase space
- ΔQ decreasing – phase space distortion for largest amplitudes

Third-order resonant extraction

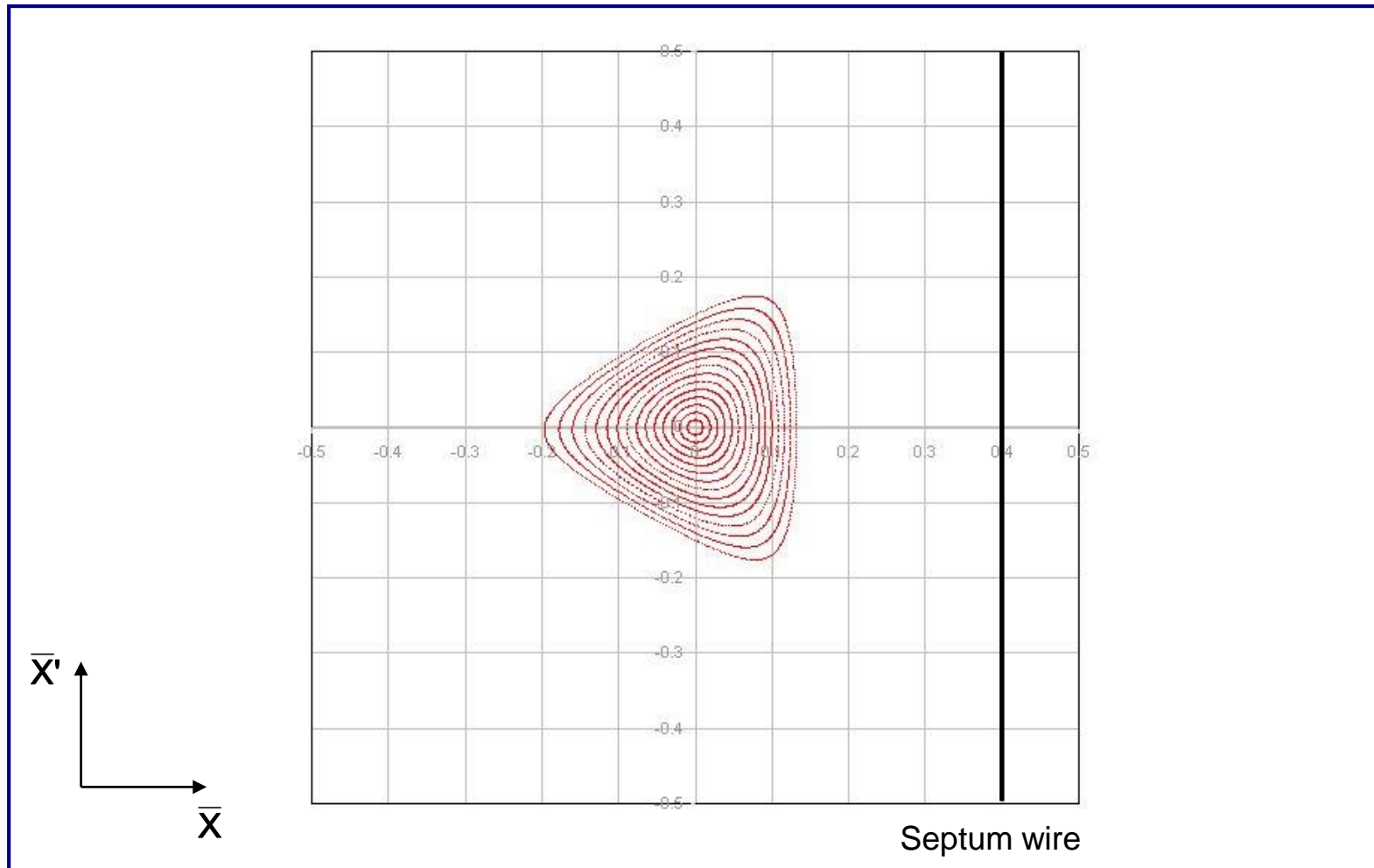

- Sextupole magnets produce a triangular stable area in phase space
- ΔQ decreasing – phase space distortion for largest amplitudes

Third-order resonant extraction

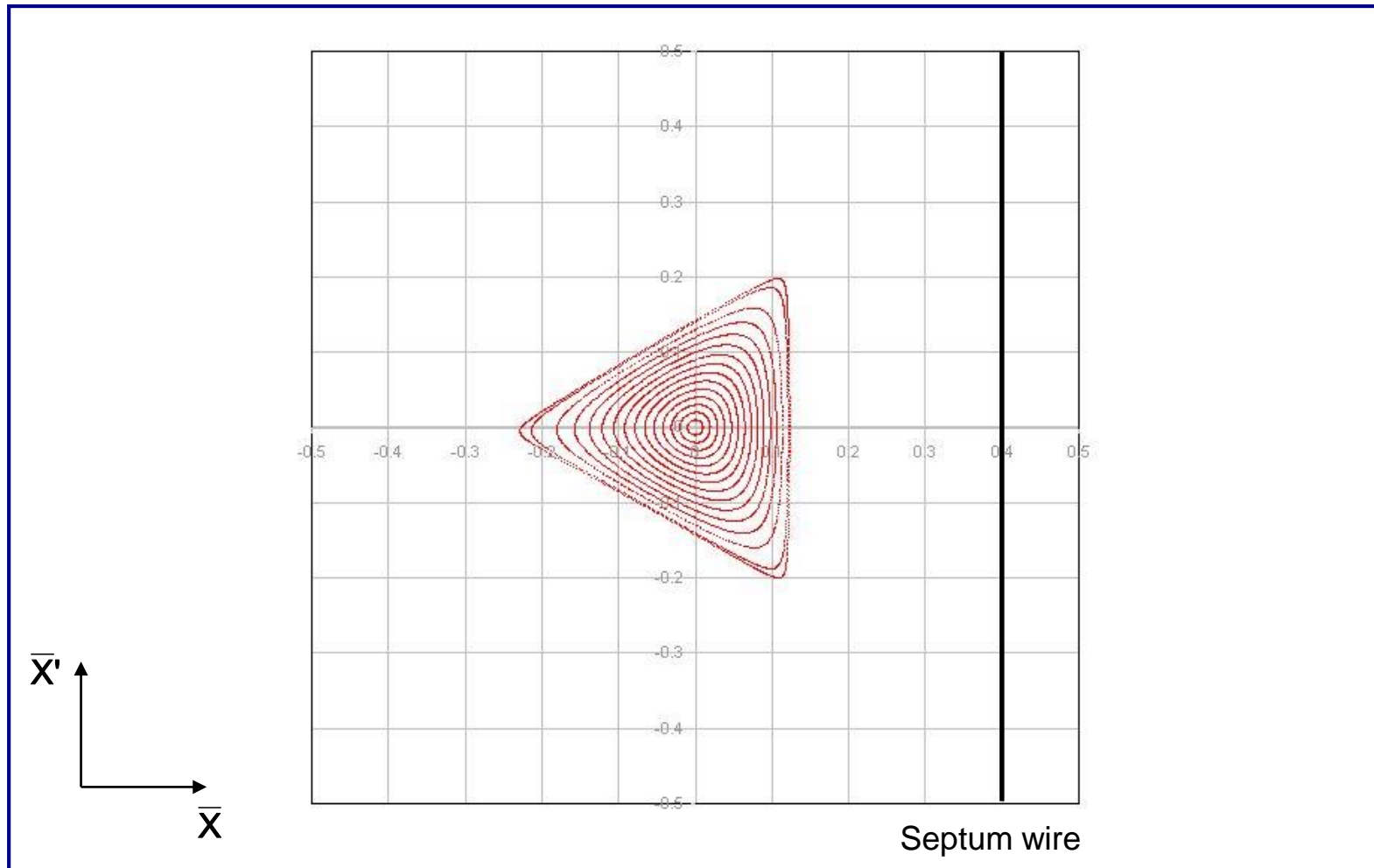

- Largest amplitude particle trajectories are significantly distorted
- Locations of fixed points noticeable at extremities of phase space triangle

Third-order resonant extraction

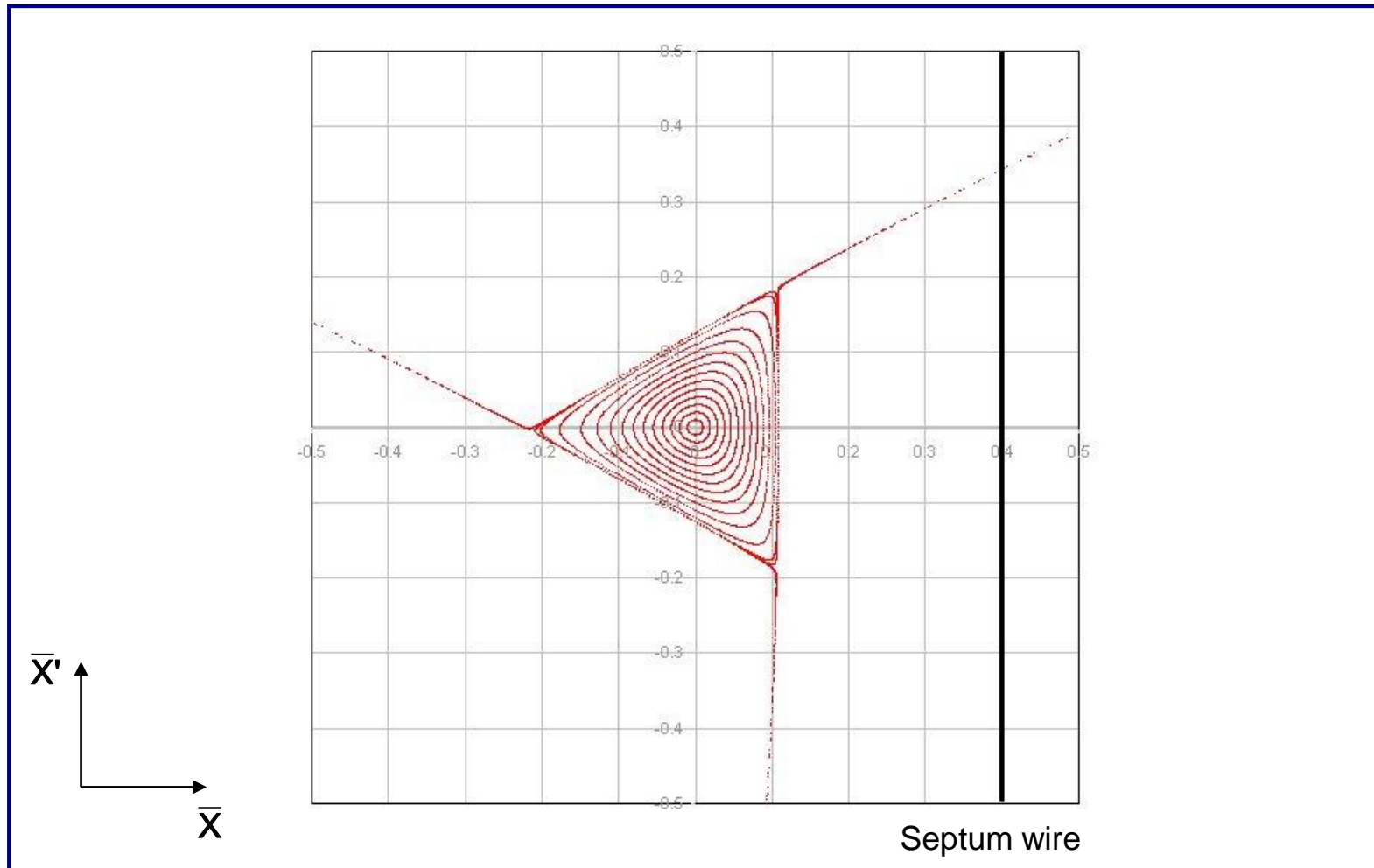

- ΔQ small enough that largest amplitude particle trajectories are unstable
- Unstable particles follow separatrix branches as they increase in amplitude

Third-order resonant extraction

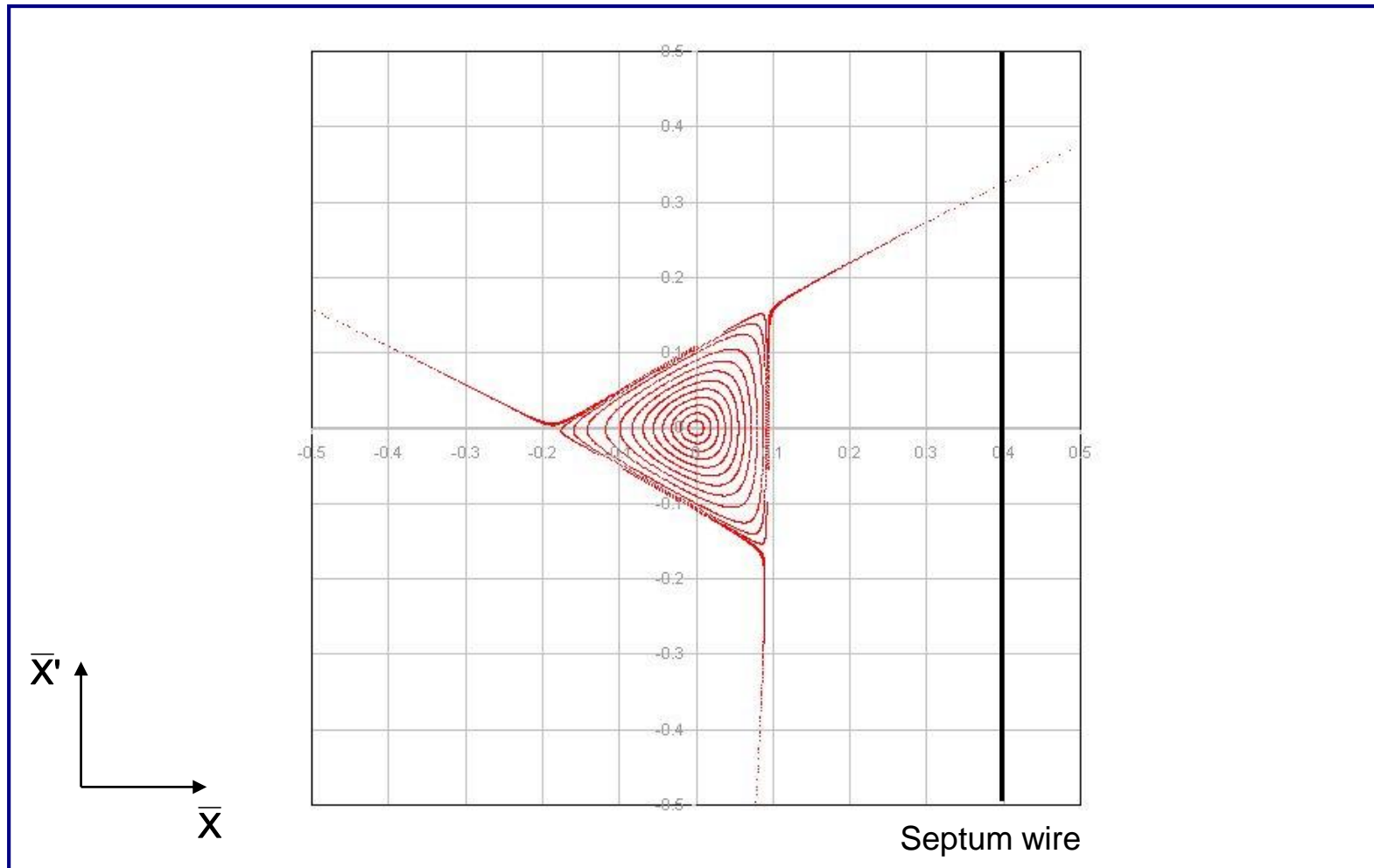

- Stable area shrinks as ΔQ becomes smaller

Third-order resonant extraction

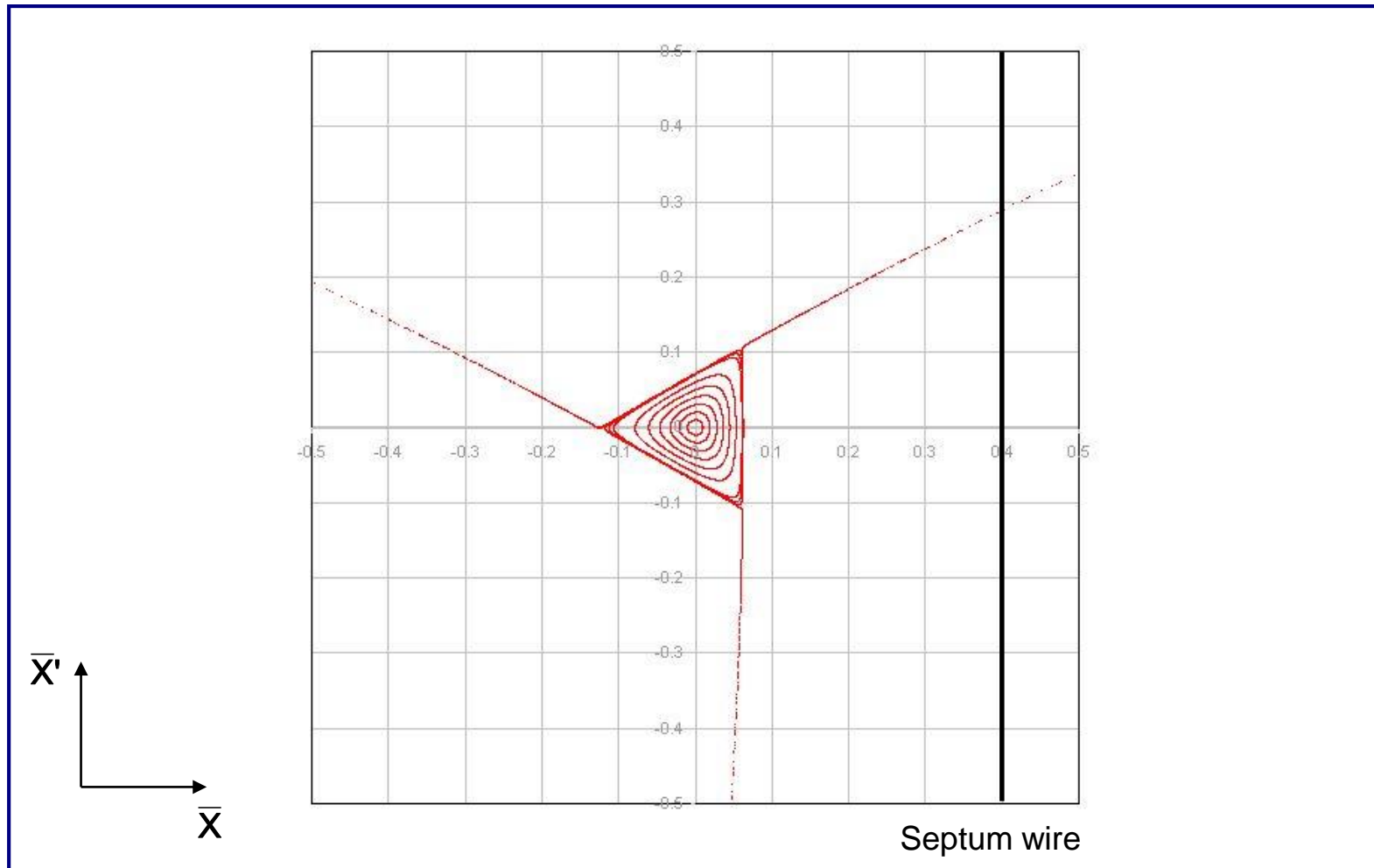

- Separatrix position in phase space shifts as the stable area shrinks

Third-order resonant extraction

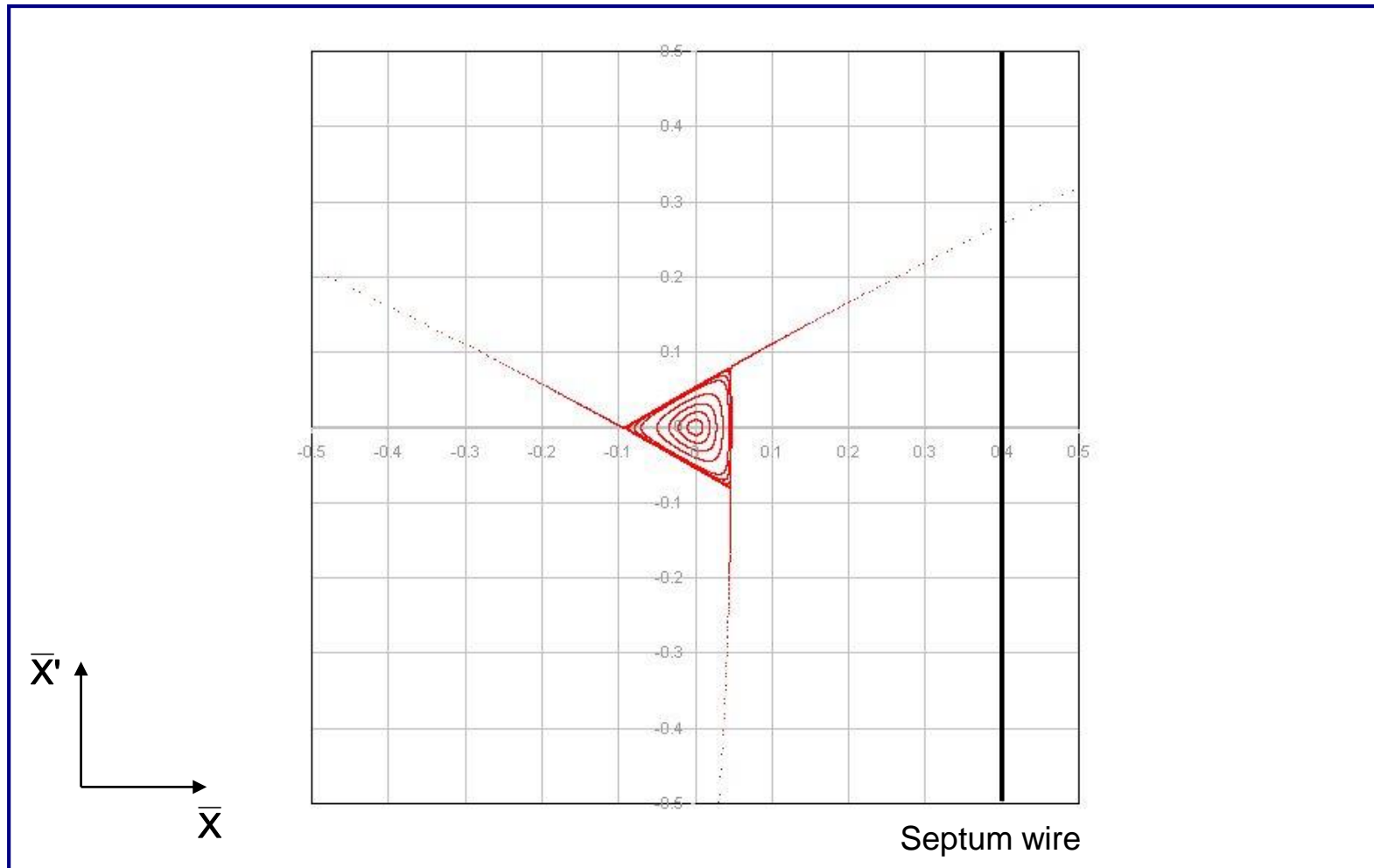

- As the stable area shrinks, the circulating beam intensity drops since particles are being continuously extracted

Third-order resonant extraction

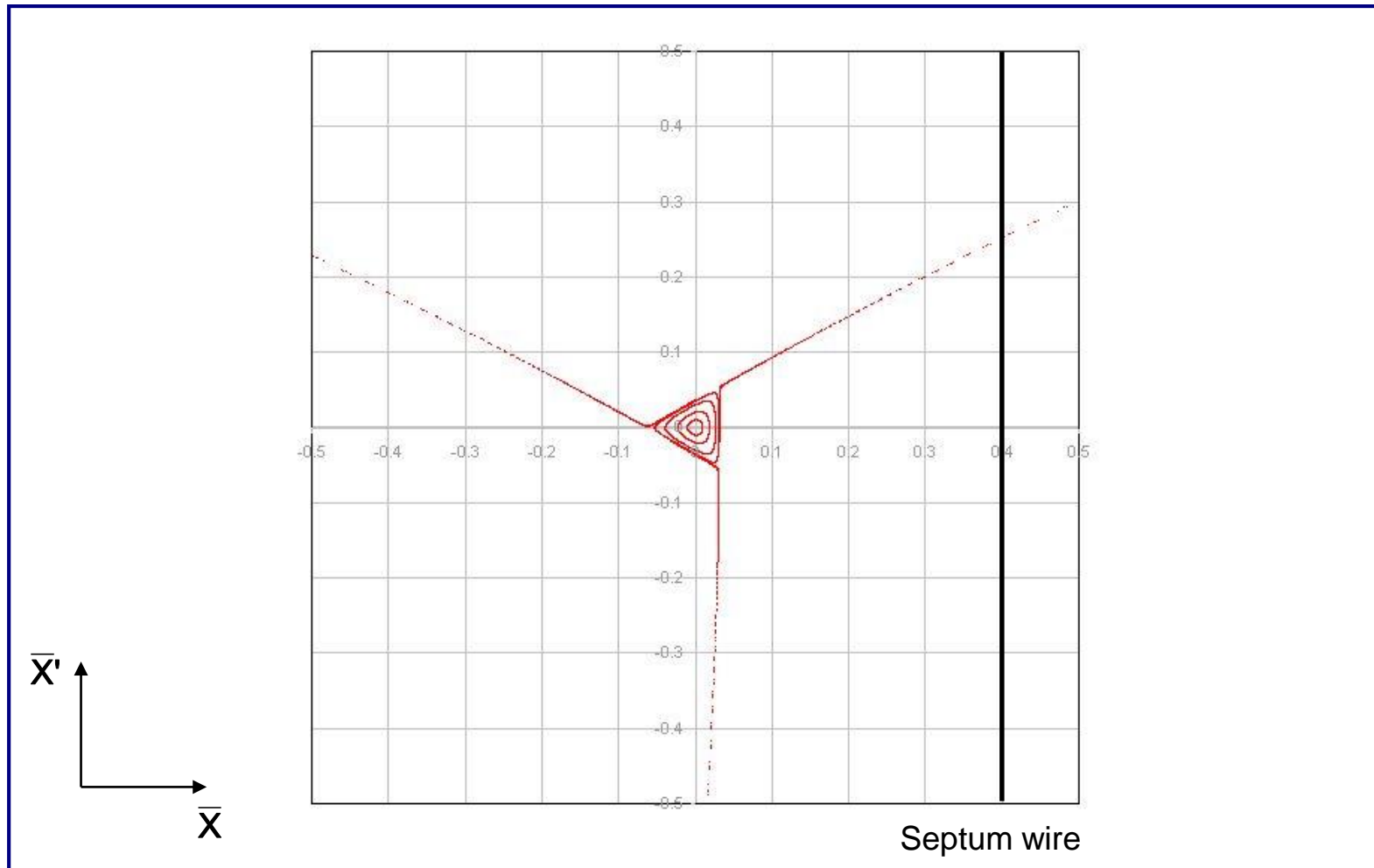

- As the stable area shrinks, the circulating beam intensity drops since particles are being continuously extracted

Third-order resonant extraction

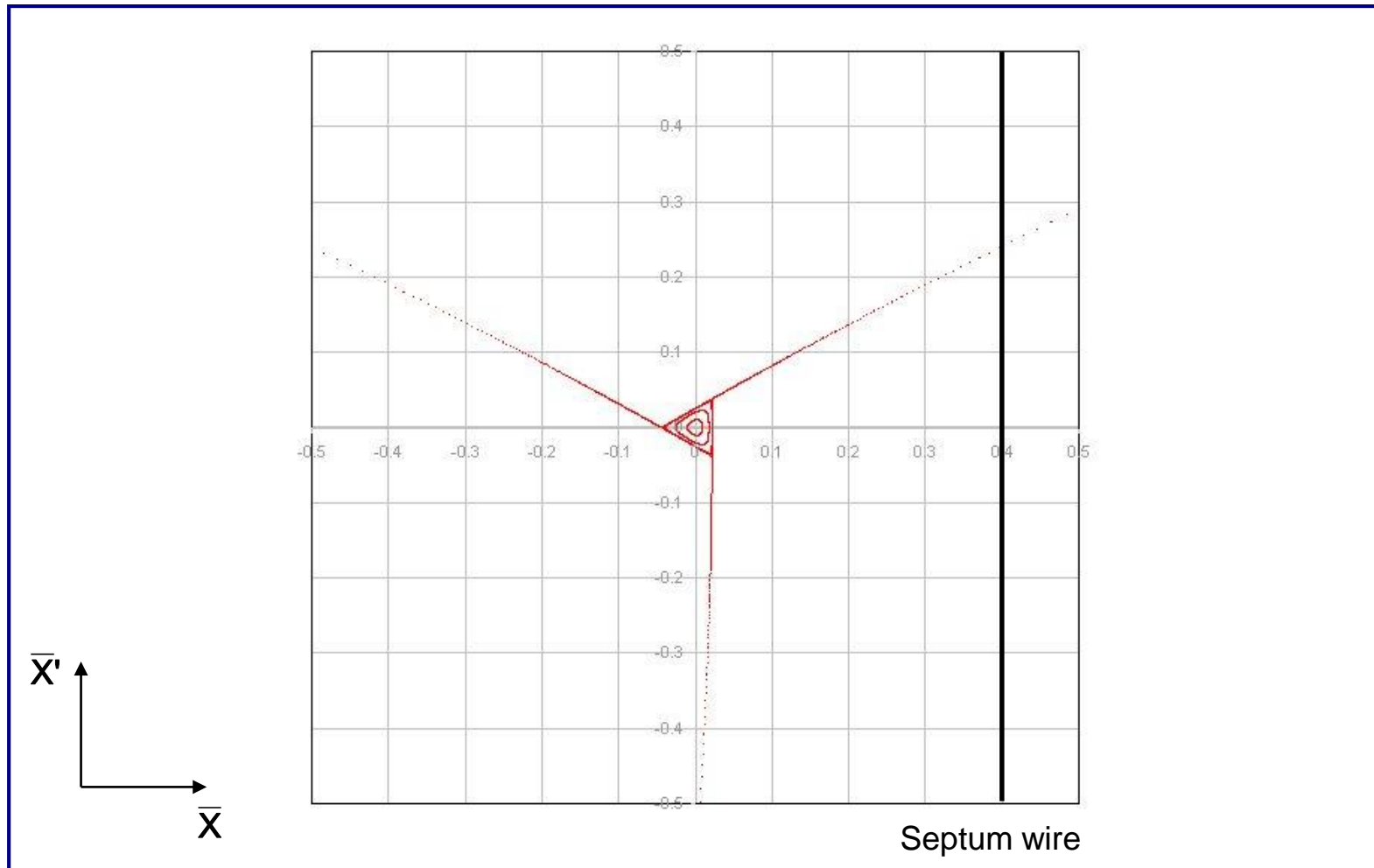

- As the stable area shrinks, the circulating beam intensity drops since particles are being continuously extracted

Third-order resonant extraction

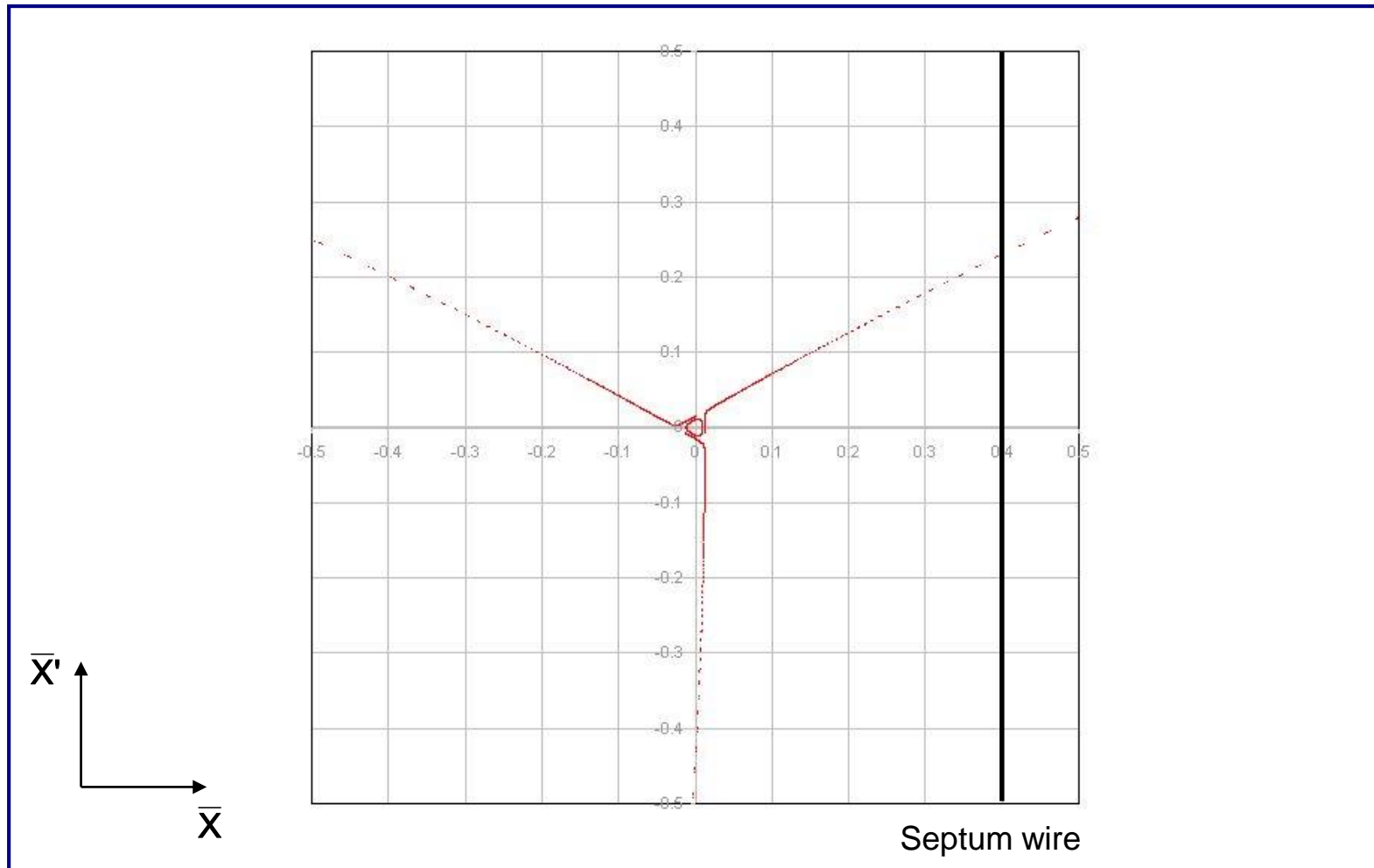

- As the stable area shrinks, the circulating beam intensity drops since particles are being continuously extracted

Third-order resonant extraction

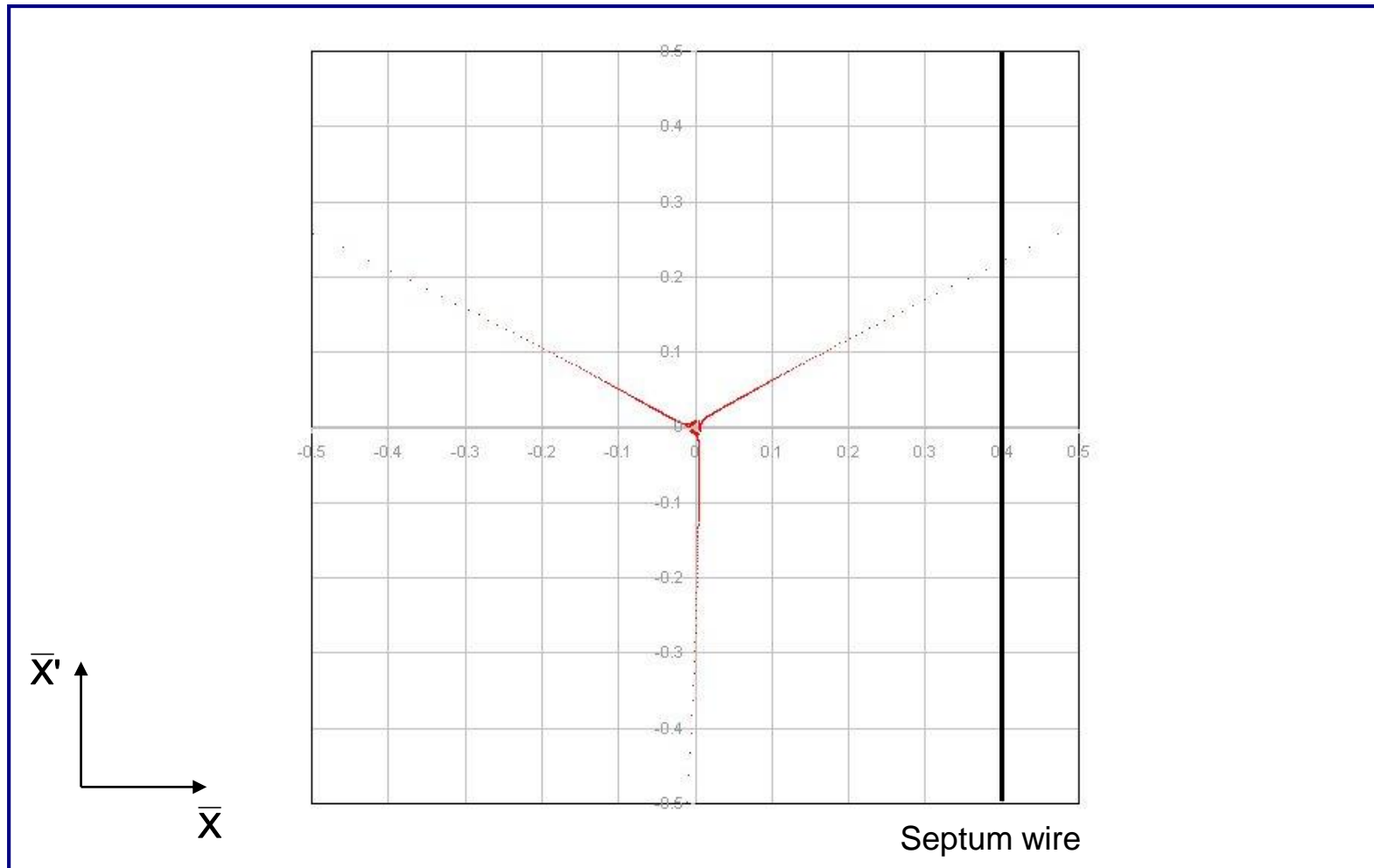

- As ΔQ approaches zero, the particles with very small amplitude are extracted

Slow extracted spill quality

- The slow-extraction is a resonant process and it amplifies the smallest imperfections in the machine:
 - e.g. spill intensity variations can be explained by ripples in the current of the quads (mains: $n \times 50$ Hz) at the level of a few ppm!
 - Injection of $n \times 50$ Hz signals in counter-phase on dedicated quads can be used to compensate

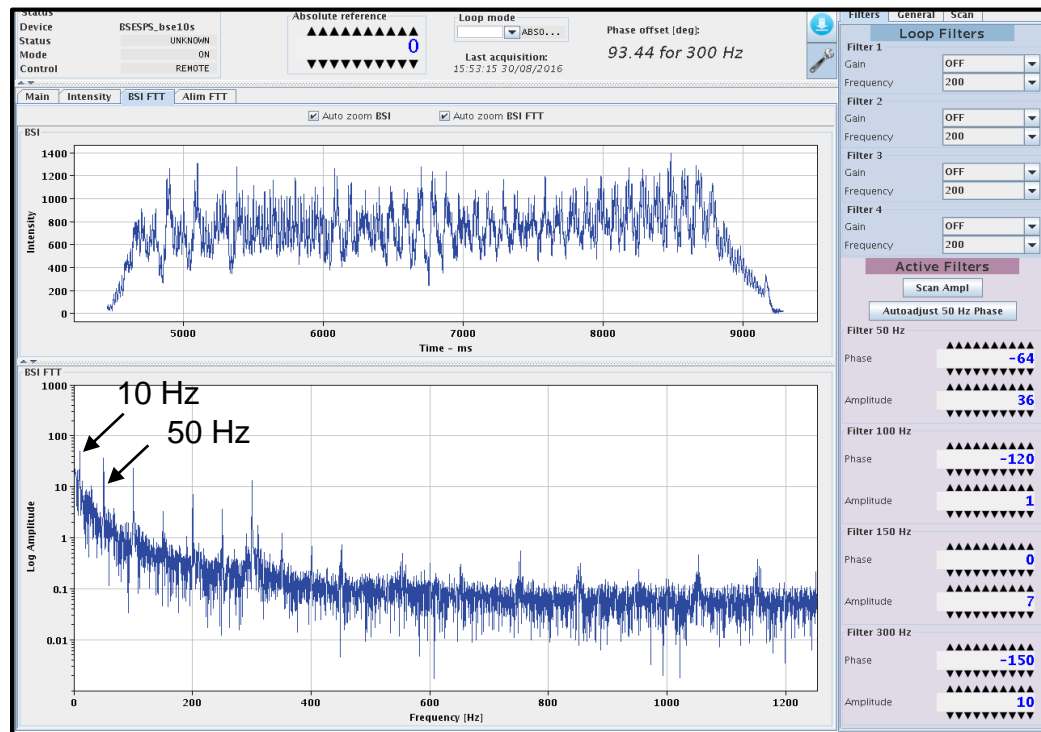

An example of a spill at SPS to the North Area with large $n \times 50$ Hz components and another noise source at 10 Hz

Extraction - summary

- Several different techniques:
 - **Single-turn fast extraction:**
 - for transfer between machines in accelerator chain, beam abort, etc.
 - **Non-resonant (fast) multi-turn extraction**
 - slice beam into equal parts for transfer between machine over a few turns.
 - **Resonant low-loss (fast) multi-turn extraction**
 - create stable islands in phase space: slice off over a few turns.
 - **Resonant (slow) multi-turn extraction**
 - create stable area in phase space \Rightarrow slowly drive particles into resonance \Rightarrow long spill over many thousand turns.

Linking Machines

1. **Extract** a beam out of one machine → initial beam parameters
 2. **Transport** this beam towards the following machine (or experiment)
 3. **Inject** this beam into a following machine with a predefined optics
- Transfer line optics has to produce required beam parameters for matching

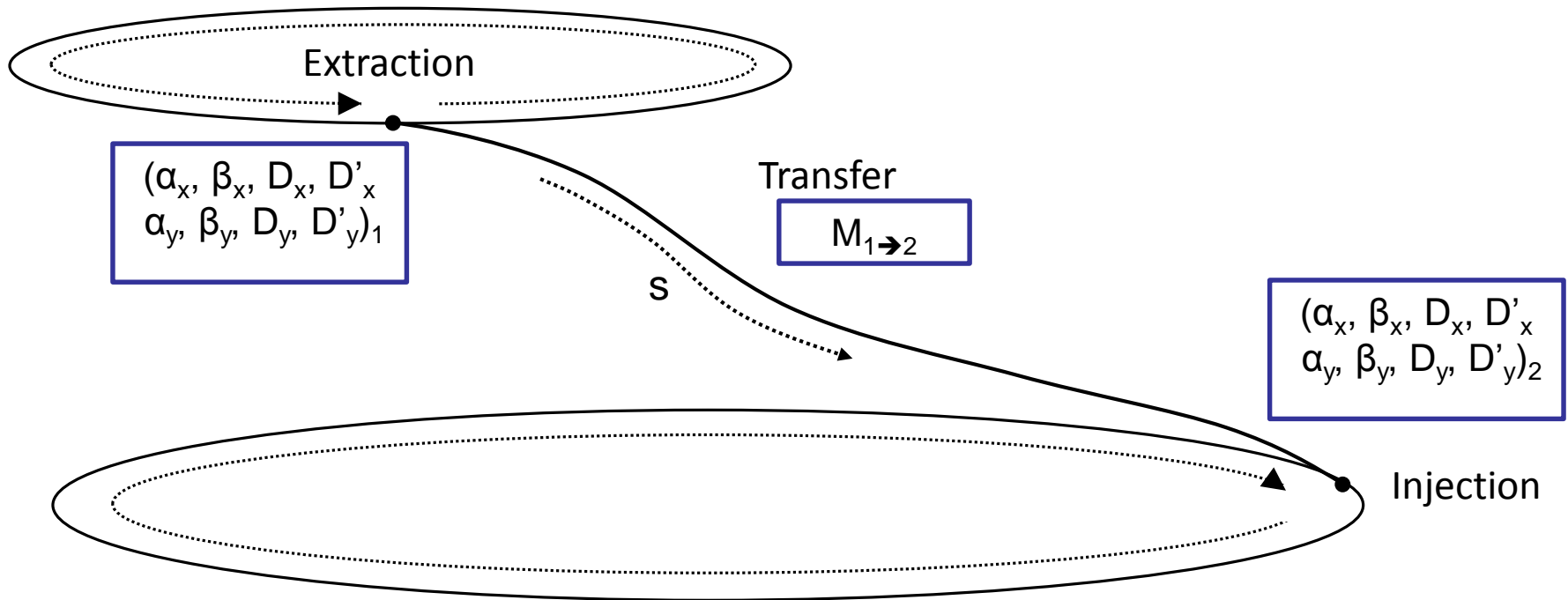

Linking Machines

- Beams have to be transported from extraction of one machine to injection of the next machine:
 - Trajectory must be matched in all 6 geometric degrees of freedom ($x, y, z, \theta, \Phi, \psi$)
- Linking the optics is a complicated process:
 - Parameters at start of line have to be propagated to matched parameters at the end of the line (injection to another machine, fixed target etc.)
 - Need to “match” 8 variables ($\alpha_x, \beta_x, D_x, D'_x$ and $\alpha_y, \beta_y, D_y, D'_y$)
 - Done with number of independently power (“matching”) quadrupoles
 - Maximum β and D values are imposed by magnetic apertures
 - Other constraints exist:
 - Phase conditions for collimators
 - Insertions for special equipment like stripping foils
 - ...
- Matching with computer codes and relying on mixture of theory, experience, intuition, trial and error.

Optics Matching example

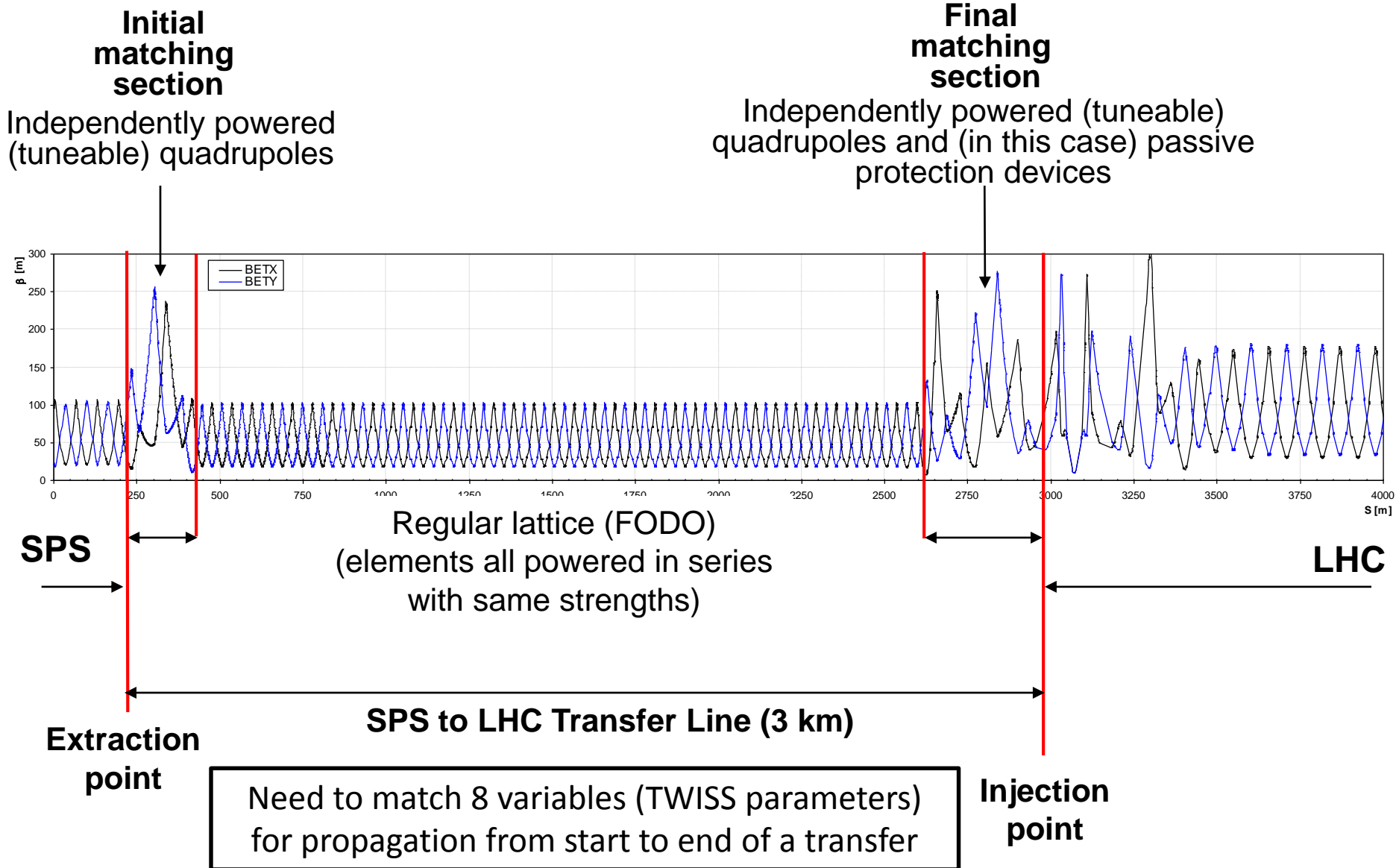

Optical Mismatch at Injection

- Filamentation fills larger ellipse with same shape as matched ellipse

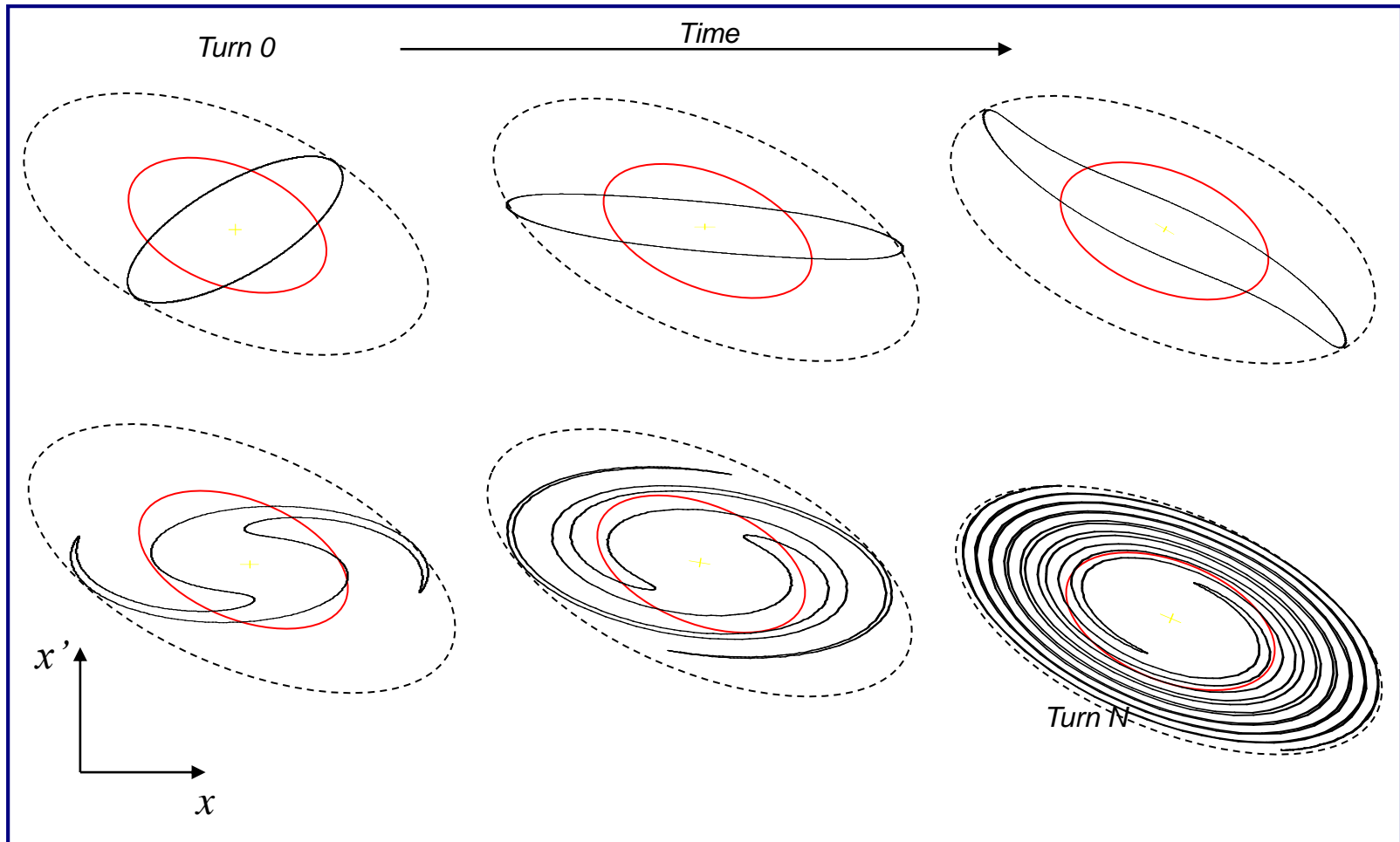

- Dispersion mismatch at injection will also cause emittance blow-up

Further reading and references

- Lots of resources presented at the recent Specialised CAS School:
- Beam Injection, Extraction and Transfer, 10-19 March 2017, Erice, Italy
- <https://cas.web.cern.ch/schools/eric-e-2017>

The CERN Accelerator School is organising a course on:

Beam Injection, Extraction and Transfer

10 - 19 March, 2017

Ettore Majorana Foundation and Centre for Scientific Culture Erice, Italy

This course will be of interest to staff and students in accelerator laboratories, university departments and companies manufacturing accelerator equipment who wish to learn about accelerator science and technology.

The course focuses on various aspects of particle injection and extraction and beam transfer and introduces the state of the art techniques of hardware components used in modern accelerators. Participants will have the opportunity to work on realistic case studies as an integral part of the program.

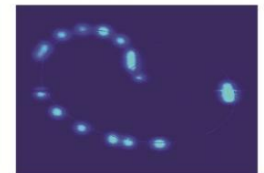
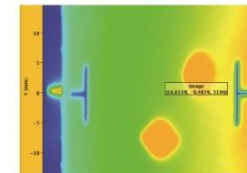
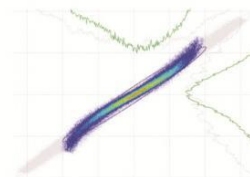
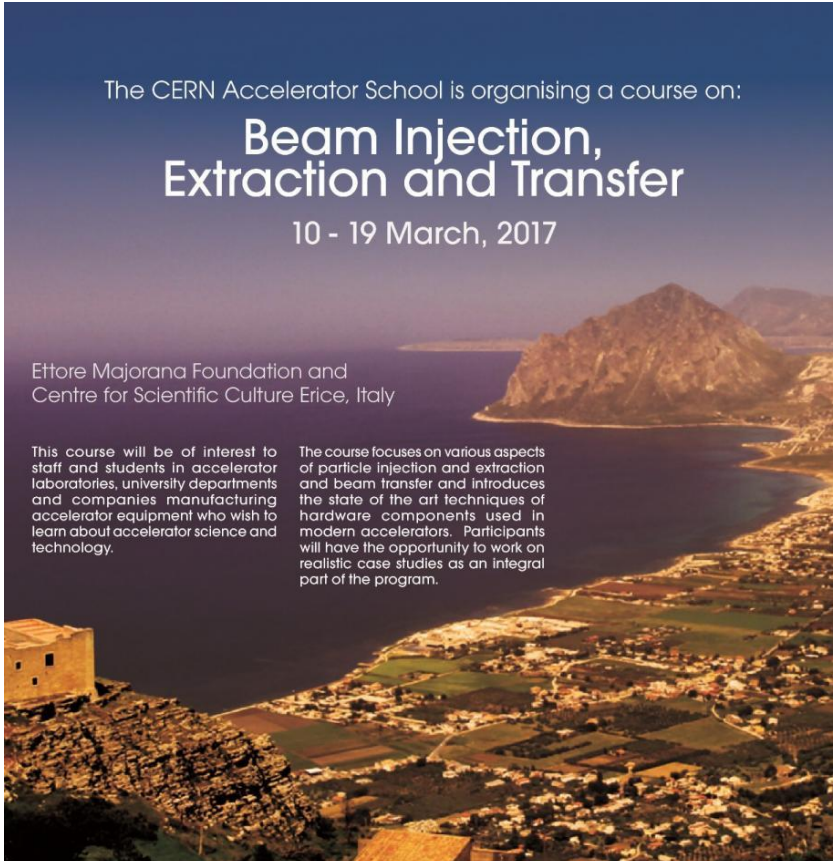

Simplified kicker system schematic

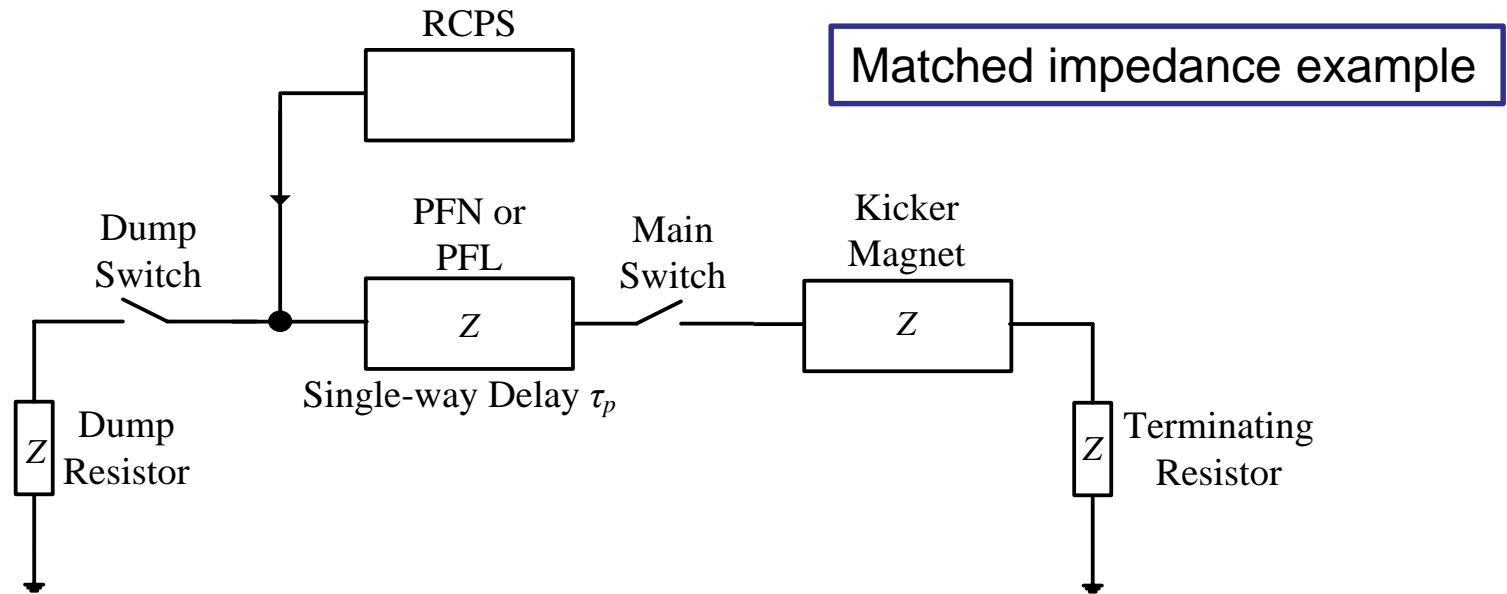

- Main sub-systems (“components”) of kicker system;
 - **RCPS** = Resonant Charging Power Supply
 - **PFL** = Pulse Forming Line (coaxial cable) or **PFN** = Pulse Forming Network (lumped elements)
 - Fast high power switch(es)
 - **Transmission line(s)**: coaxial cable(s)
 - **Kicker Magnet**
 - **Terminators** (resistive)

Simplified kicker system schematic

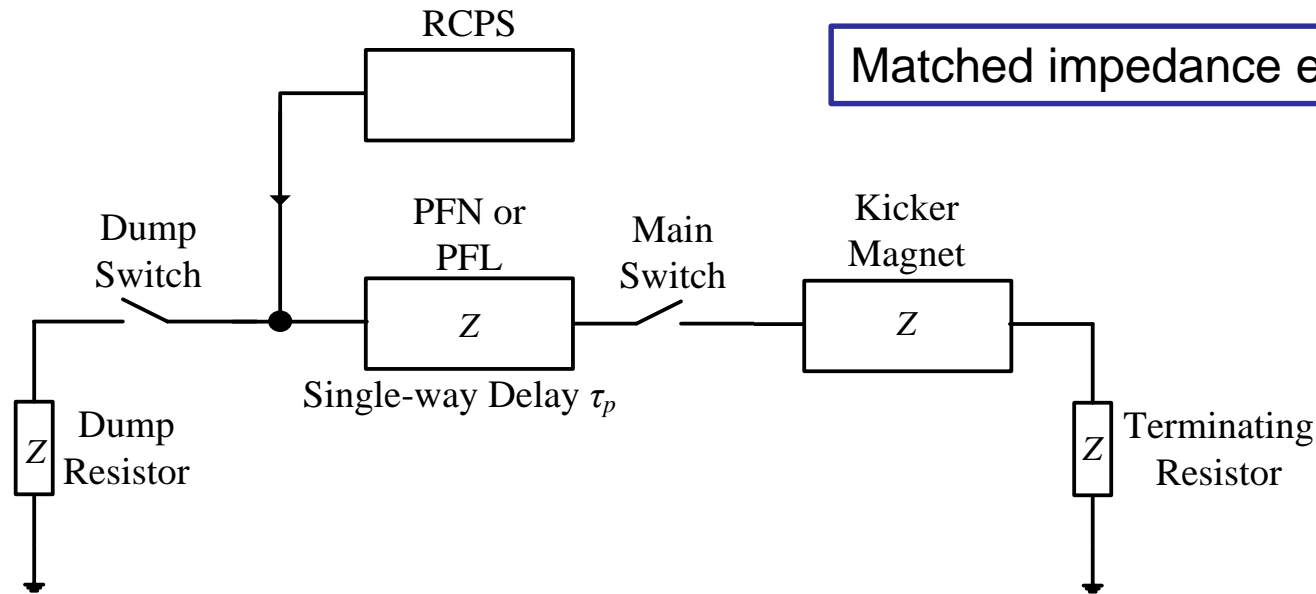

- PFL/PFN charged to voltage V_0 by the RCPS
- Main switch is closed...
 - ...voltage pulse of $V_0/2$ flows through kicker
- Once the pulse reaches the (matched) terminating resistor full-field has been established in the kicker magnet
- Pulse length controlled between $t = 0$ and $2 \tau_p$ with dump switch

PFL/PFN

Pulse Forming Line (PFL)

- Low-loss coaxial cable
- Fast and ripple-free pulses
- Attenuation (droop $\sim 1\%$) becomes problematic for pulses $> 3 \mu\text{s}$
- Above 50 kV SF6 pressurized PE tape cables are used
- Bulky: $3 \mu\text{s}$ pulse ~ 300 m of cable

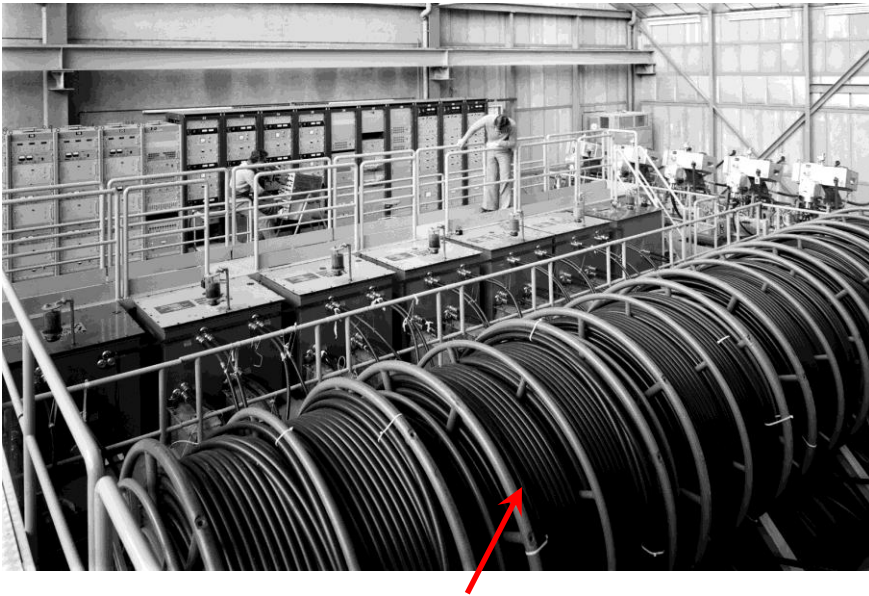

Reels of PFL used at the PS complex (as old as the photograph!)

Pulse Forming Network (PFN)

- Artificial coaxial cable made of lumped elements
- For low droop and long pulses $> 3 \mu\text{s}$
- Each cell individually adjustable: adjustment of pulse flat-top difficult and time consuming.

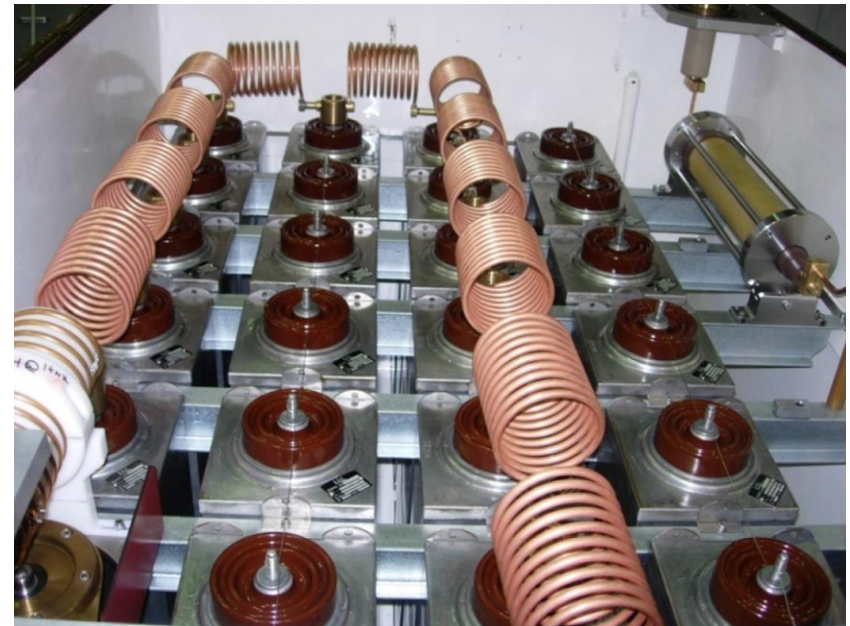

SPS extraction kicker (MKE) PFN (17 cells)

Switches

Thyratrons

- Deuterium gas thyratrons are commonly used
- Hold off 80 kV and switch up to 6 kA
- Fast switching ~ 30 ns (~ 150 kA/ μ s)
- Erratic turn-on: use with RCPS to reduce hold-off time

Power semiconductor switches

- Suitable for scenarios where erratic turn-on is not allowed
- For example, LHC beam dump kickers held at nominal voltage throughout operation (>10 h) ready to fire and safely abort at any moment.
- Hold off up to 30 kV and switch up to 18 kA
- Slower switching > 1 μ s (~ 18 kA/ μ s)
- Low maintenance



Stack of high-power semiconductor switches (GTOs)

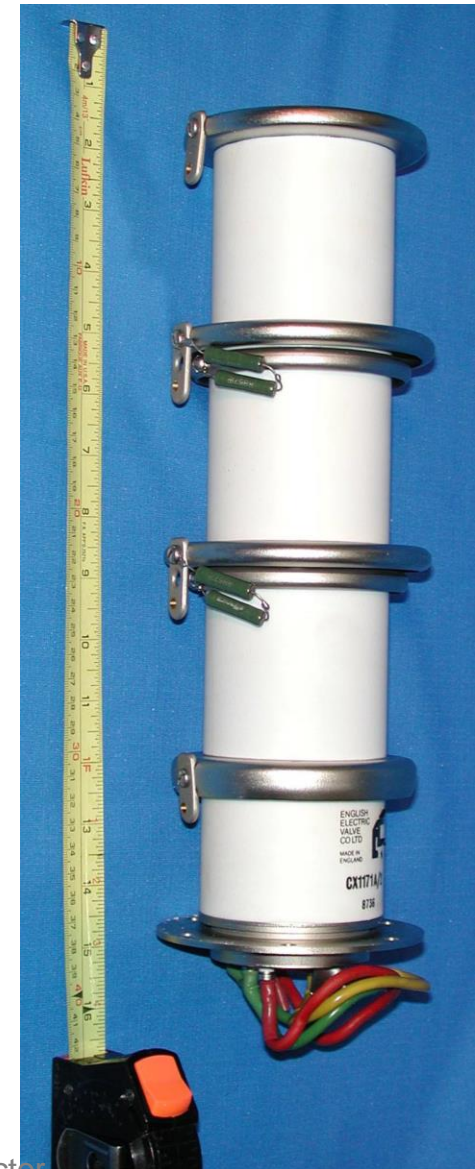

Thyratron

Simplified kicker system schematic

$t = 0$

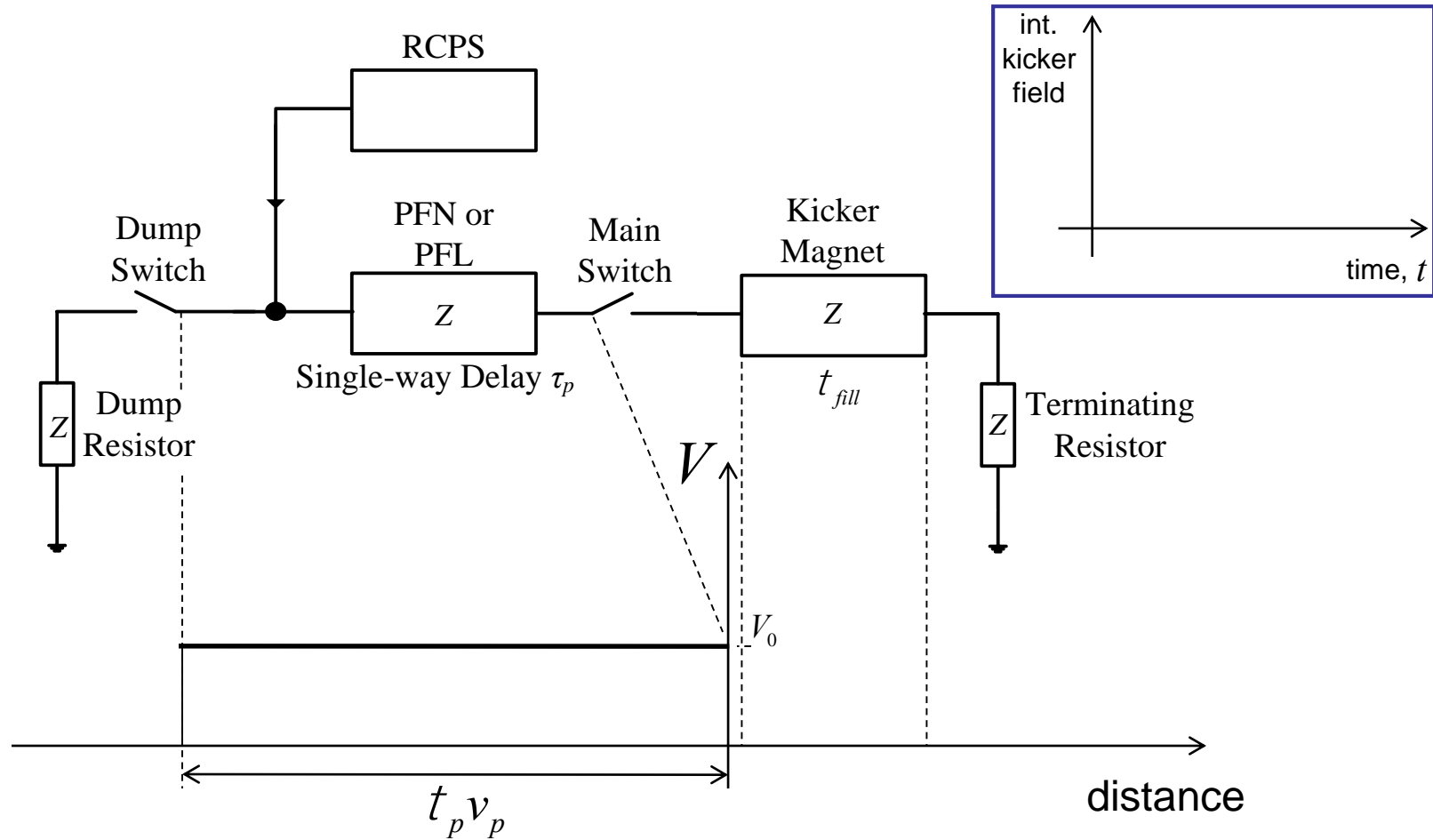

- Pulse forming network or line (PFL/PFN) charged to voltage V_0 by the resonant charging power supply (RCPS)
 - RCPS is de-coupled from the system through a diode stack

Simplified kicker system schematic

$$t = 2t_p + t_{fill}$$

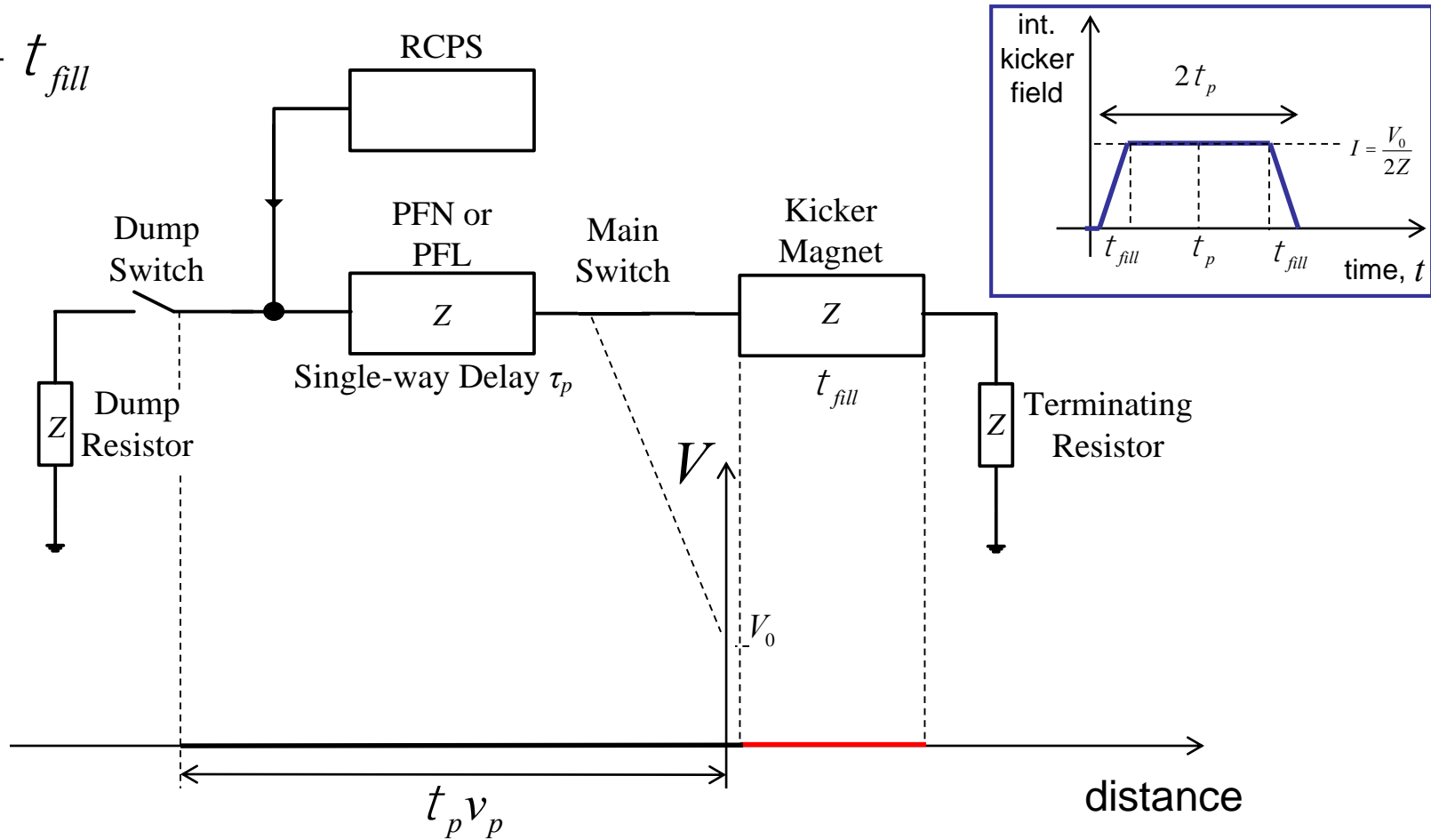

- A kicker pulse of approximately $2 \tau_p$ is imparted on the beam and all energy has been emptied into the terminating resistor

Simplified kicker system schematic

$$t \gg 2t_p$$

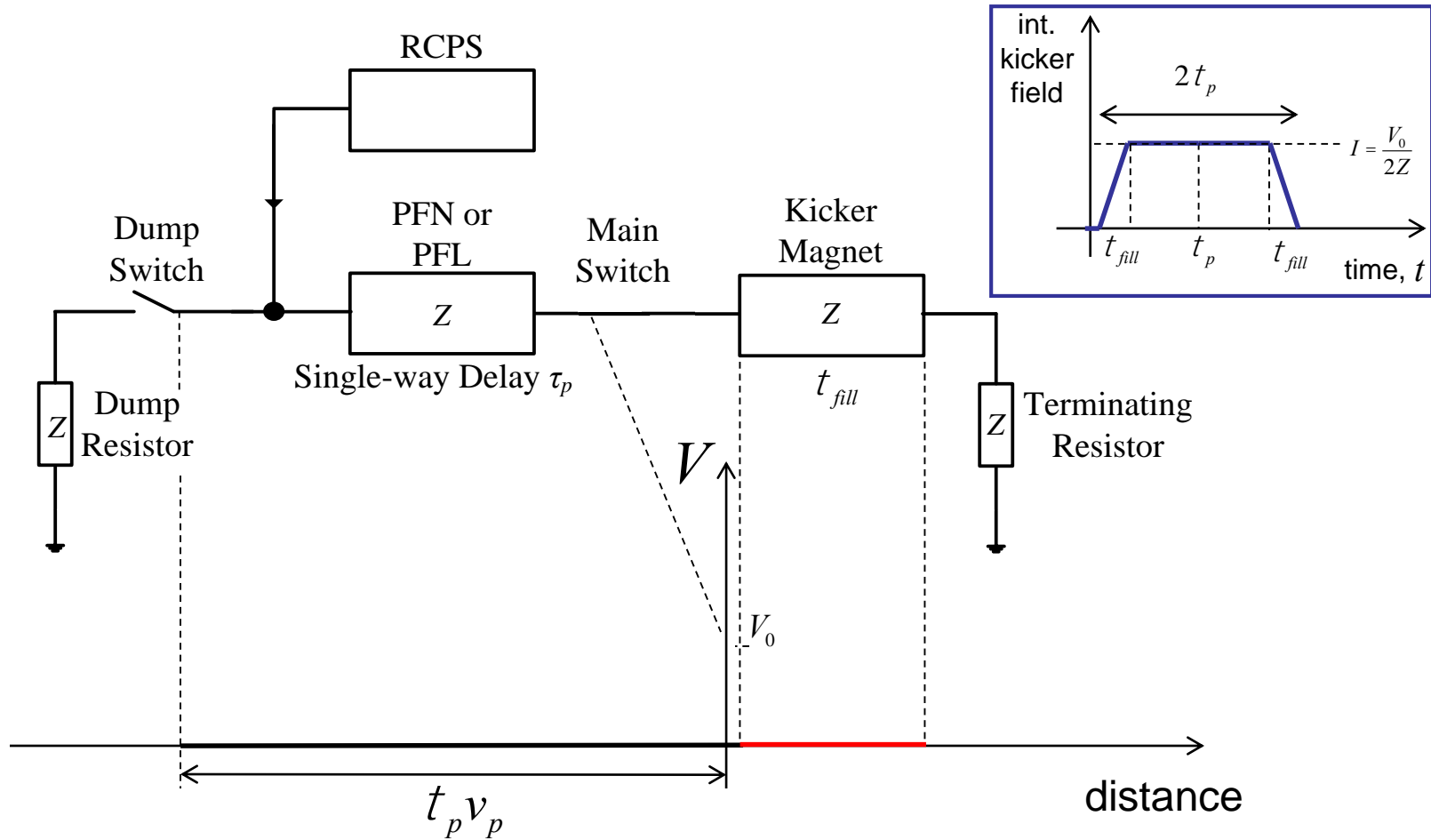

- Kicker pulse length can be changed by adjusting the relative timing of dump and main switches:
 - e.g. if the dump and main switches are fired simultaneously the pulse length will be halved and energy shared on dump and terminating resistors

Short circuit mode

- **Short-circuiting** the termination offers **twice the kick** (for a given kicker magnet):
 - **Fill time** of kicker magnet is **doubled**
 - Diode as dump switch provides solution for fixed pulse length

$$t \gg 2(t_p + t_{fill})$$

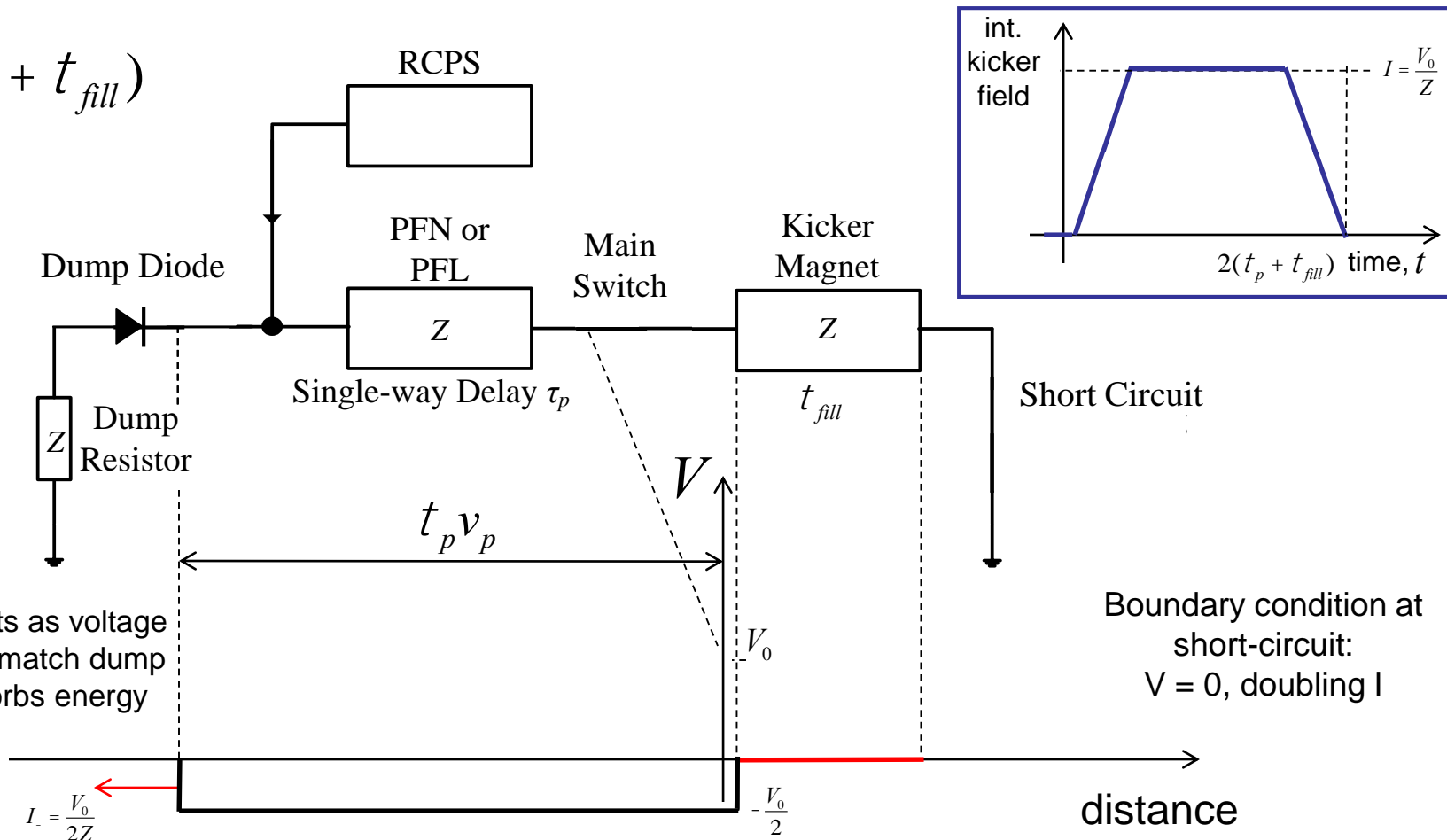

Kicker magnets – design options

- Type: “lumped inductance” or “distributed inductance” (**transmission line**)

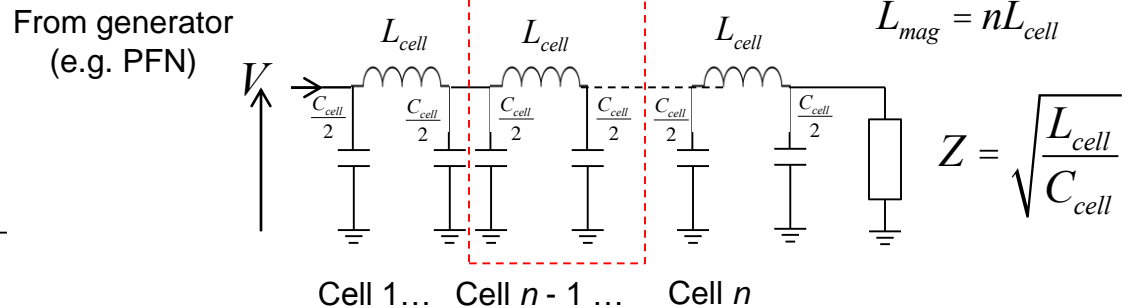
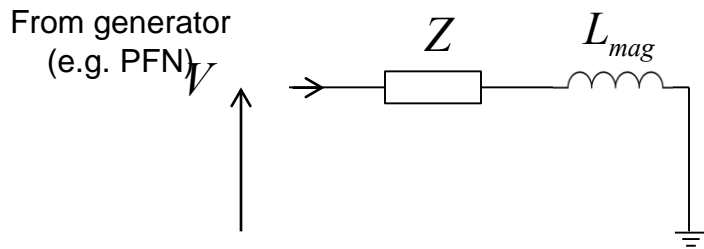

- simple magnet design
- magnet must be nearby the generator to minimise inductance
- exponential field rise-time:

$$I = \frac{V}{Z}(1 - e^{-t/\tau}) \quad \tau = \frac{L_{mag}}{Z}$$

- slow: rise-times $\sim 1 \mu\text{s}$

- complicated magnet design
- impedance matching important
- field rise-time depends on propagation time of pulse through magnet:

$$\tau = n\sqrt{L_{cell} \times C_{cell}} = n\frac{L_{cell}}{Z} = \frac{L_{mag}}{Z}$$

- fast: rise-times** $\ll 1 \mu\text{s}$

- Other considerations:

- Machine **vacuum**: kicker in-vacuum or external
- **Aperture**: geometry of ferrite core
- **Termination**: matched impedance or short-circuit

Magnets – transmission line

- Today's fast (rise-times of < few hundred ns) kicker magnets are generally **ferrite loaded** transmission lines:
 - Ferrite C-cores are sandwiched between HV plates
 - Grounded plates are interleaved to form a capacitor to ground

End View

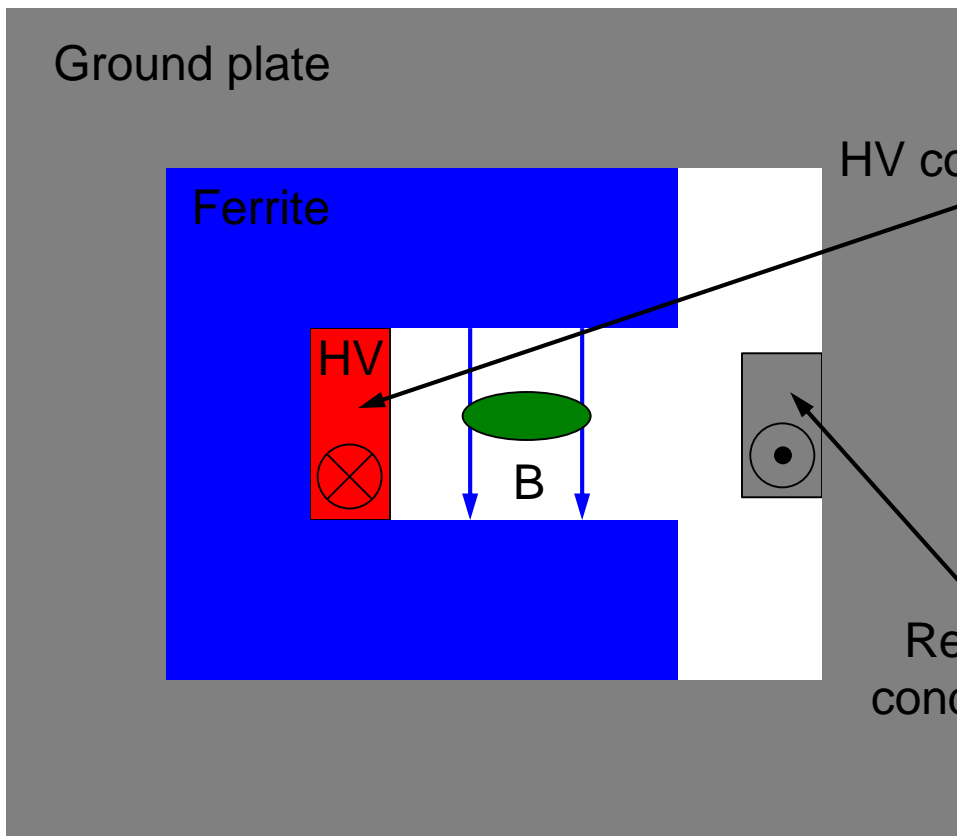

Side View

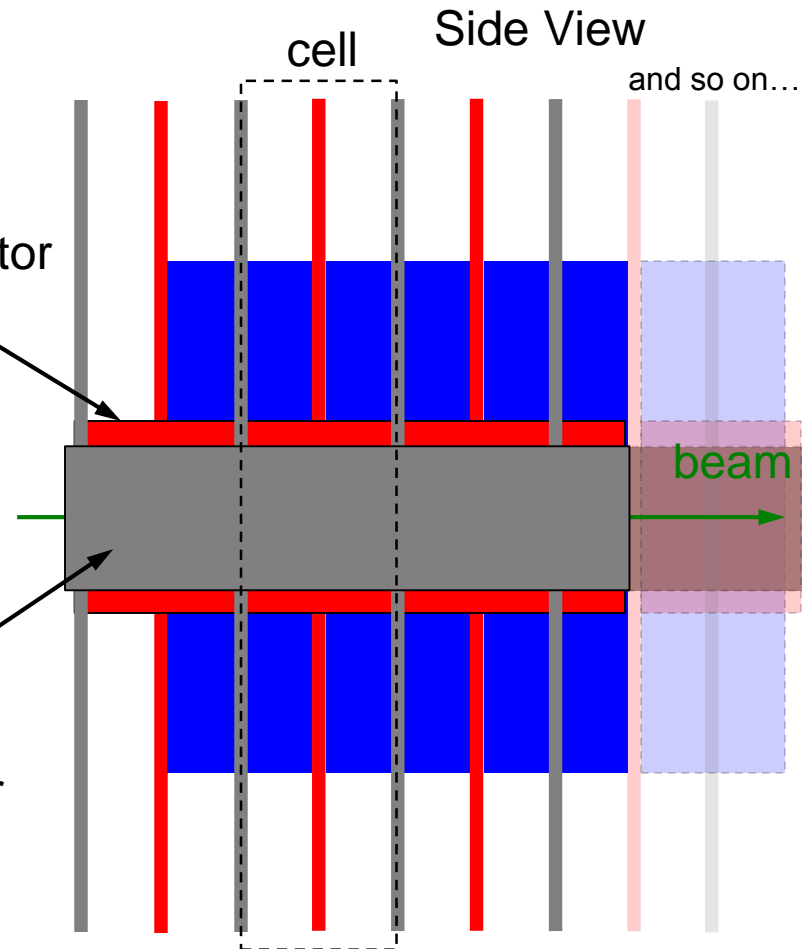

Magnets – transmission line

- Today's fast (rise-times of $<$ few hundred ns) kicker magnets are generally **ferrite loaded** transmission lines:
 - Kicker magnets consists of many, relatively short, cells to approximate a broadband coaxial cable

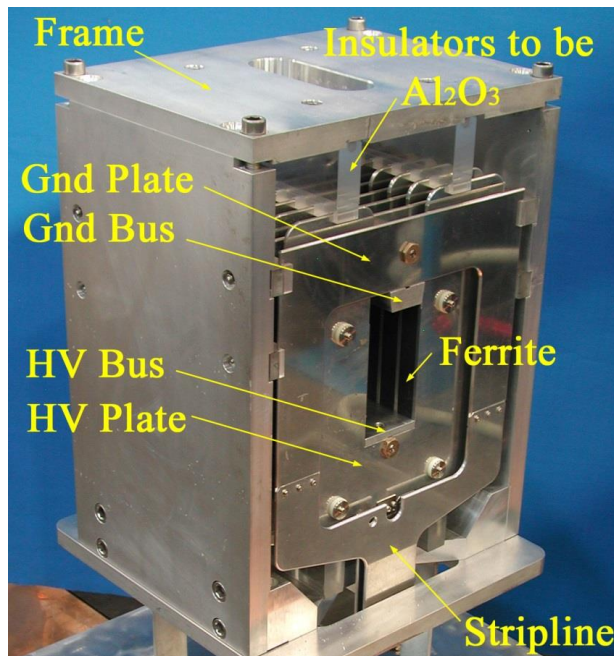

A real kicker...
Prototype for AGS
injection kicker upgrade

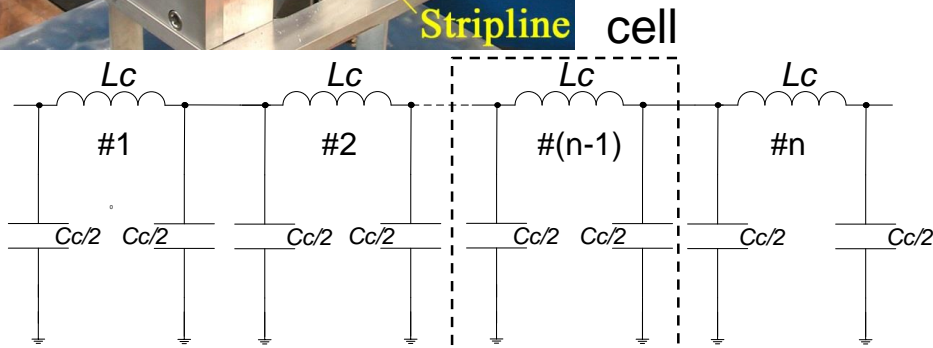
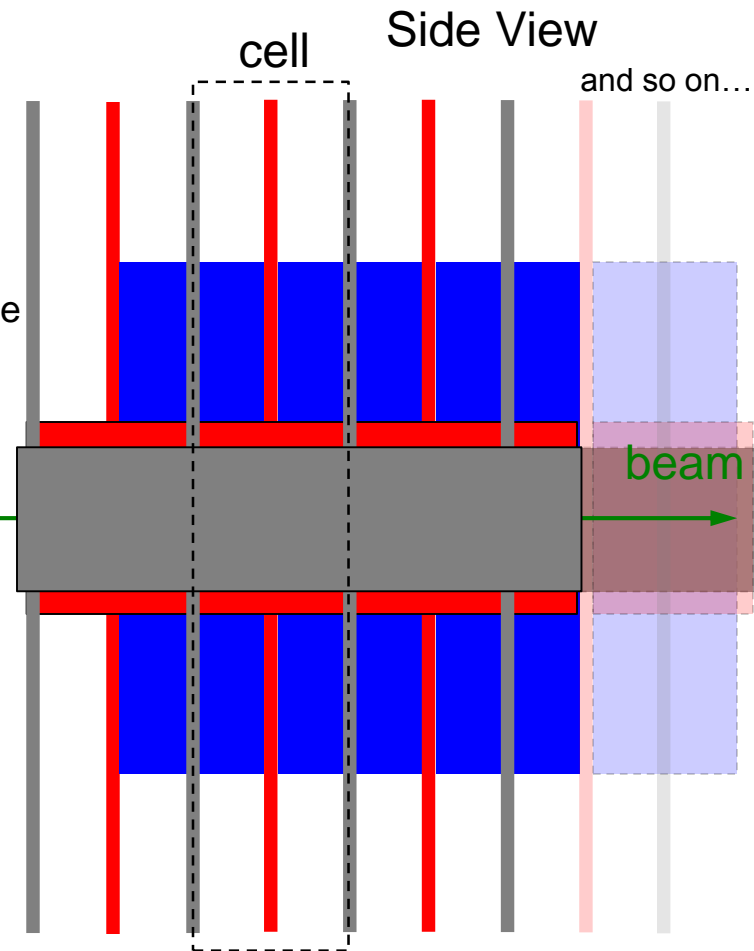
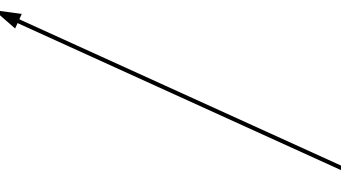

Electrostatic septum

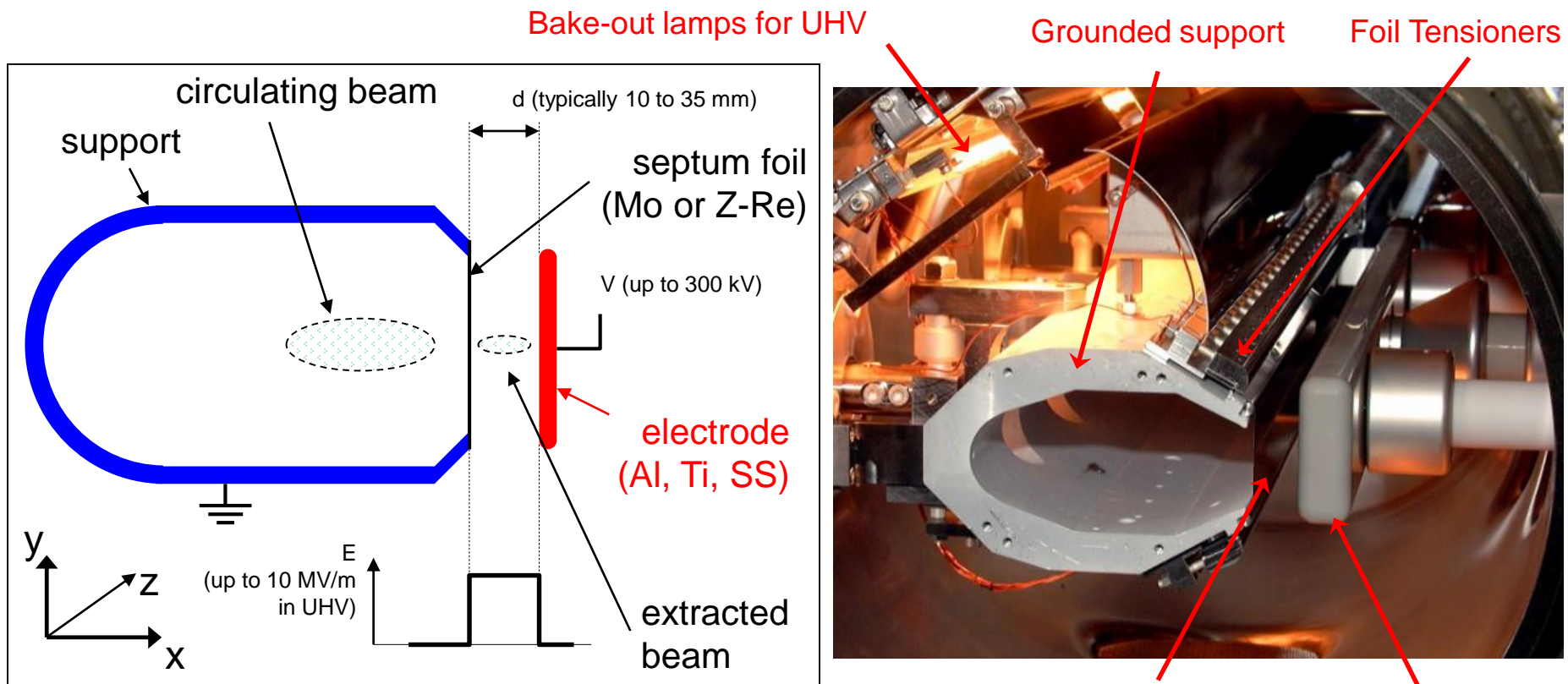

- Thin septum ~ 0.1 mm needed for high extraction efficiency:
 - Foils typically used
 - Stretched wire arrays provide thinner septa and lower effective density
- Challenges include conditioning and preparation of HV surfaces, vacuum in range of $10^{-9} - 10^{-12}$ mbar and in-vacuum precision position alignment

Electrostatic septum

- At SPS we slow-extract 400 GeV protons using approximately 15 m of septum split into 5 separate vacuum tanks each over 3 m long:
 - Alignment of the 60 - 100 μm wire array over 15 m is challenging!



DC direct drive magnetic septum

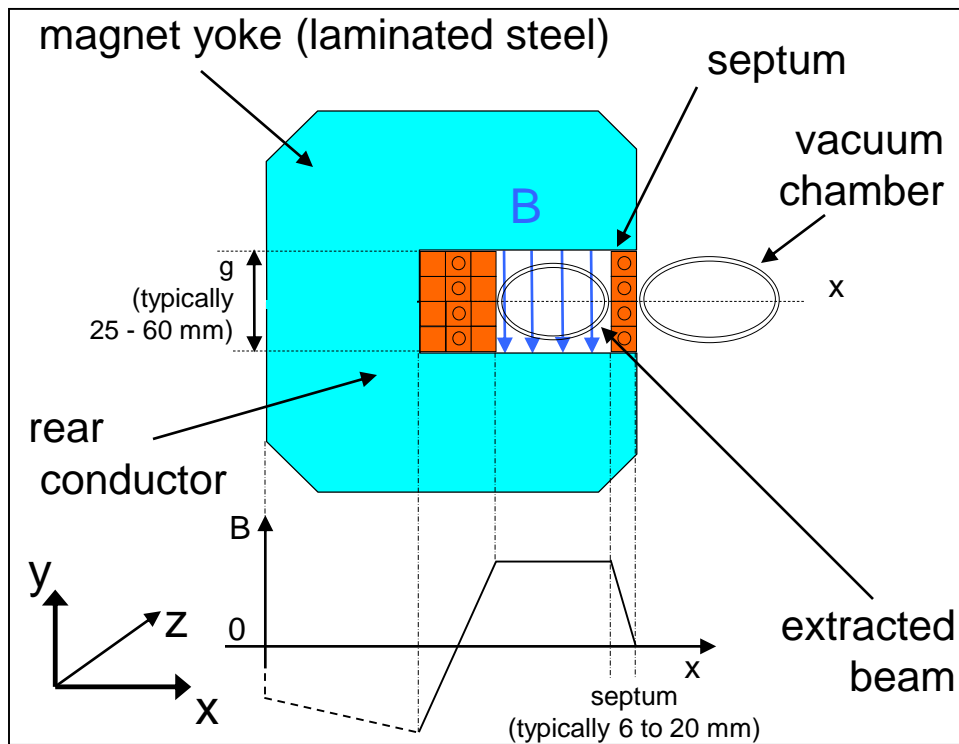

Circulating beam

Electrical connections



Cooling

- Continuously powered, rarely under vacuum
- Multi-turn coil to reduce current needed but cooling still an issue:
 - Cooling water circuits flow rate typically at 12 – 60 l/min
 - Current can range from 0.5 to 4 kA and power consumption up to 100 kW!

Direct drive pulsed magnetic septum

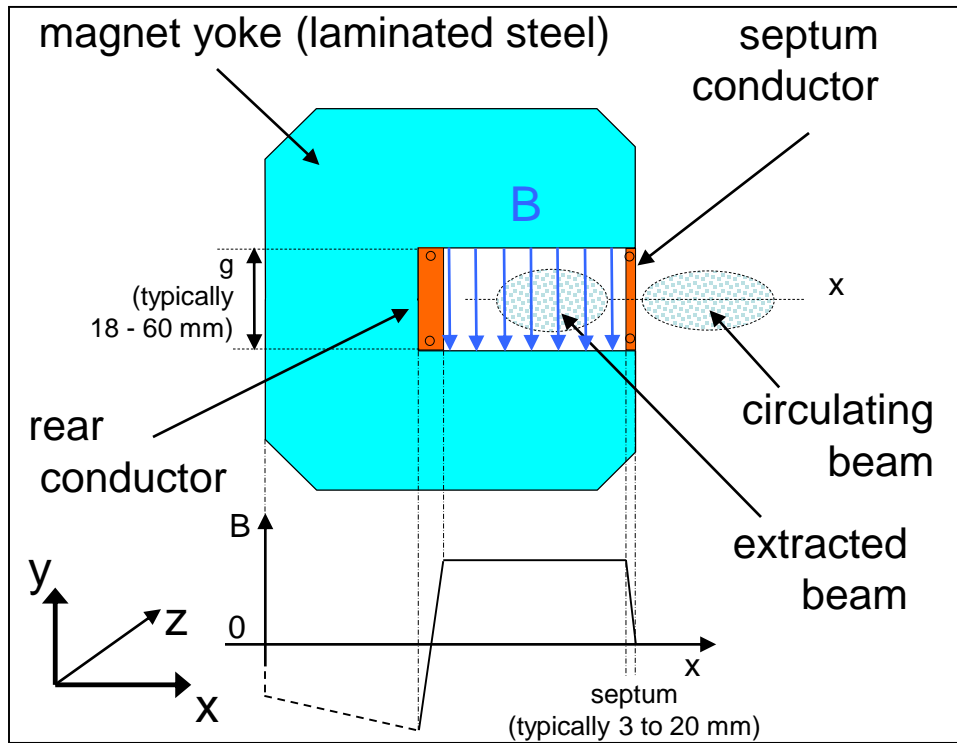

Bake-out lamps for UHV

Beam screen

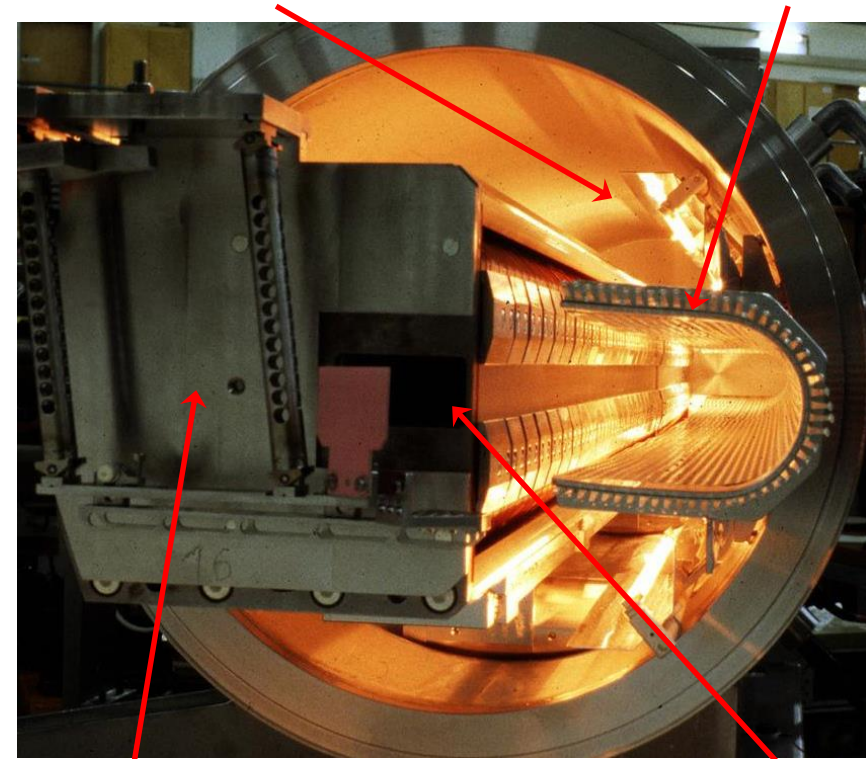

Beam "monitor"

Septum

- In vacuum, to minimise distance between circulating and extracted beam
- Single-turn coil to minimise inductance, bake-out up to 200 °C ($\sim 10^{-9}$ mbar)
- Pulsed by capacitor discharge (third harmonic flattens the pulse):
 - Current in range 7 – 40 kA with a few ms oscillation period
 - Cooling water circuits flow rate from 1 – 80 l/min

Appendix

Injection errors

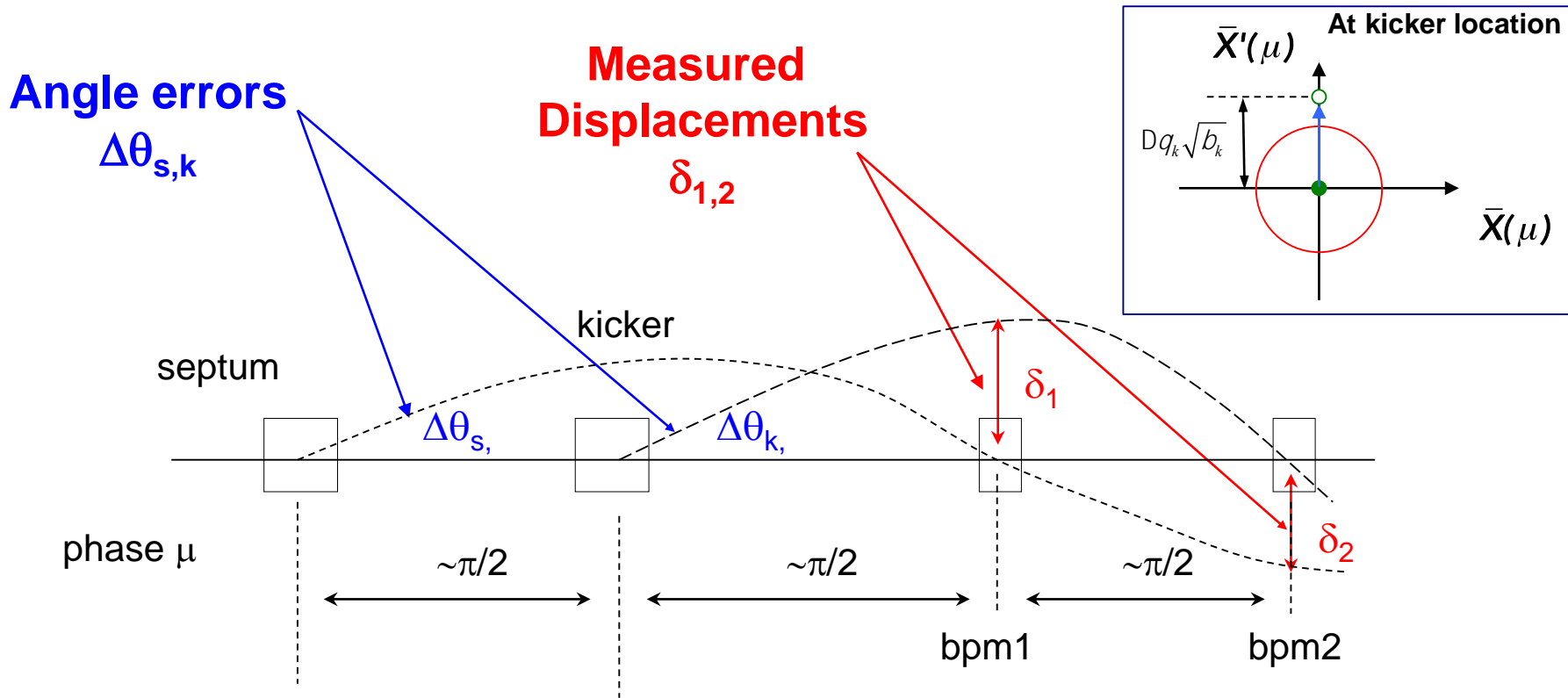

Injection errors

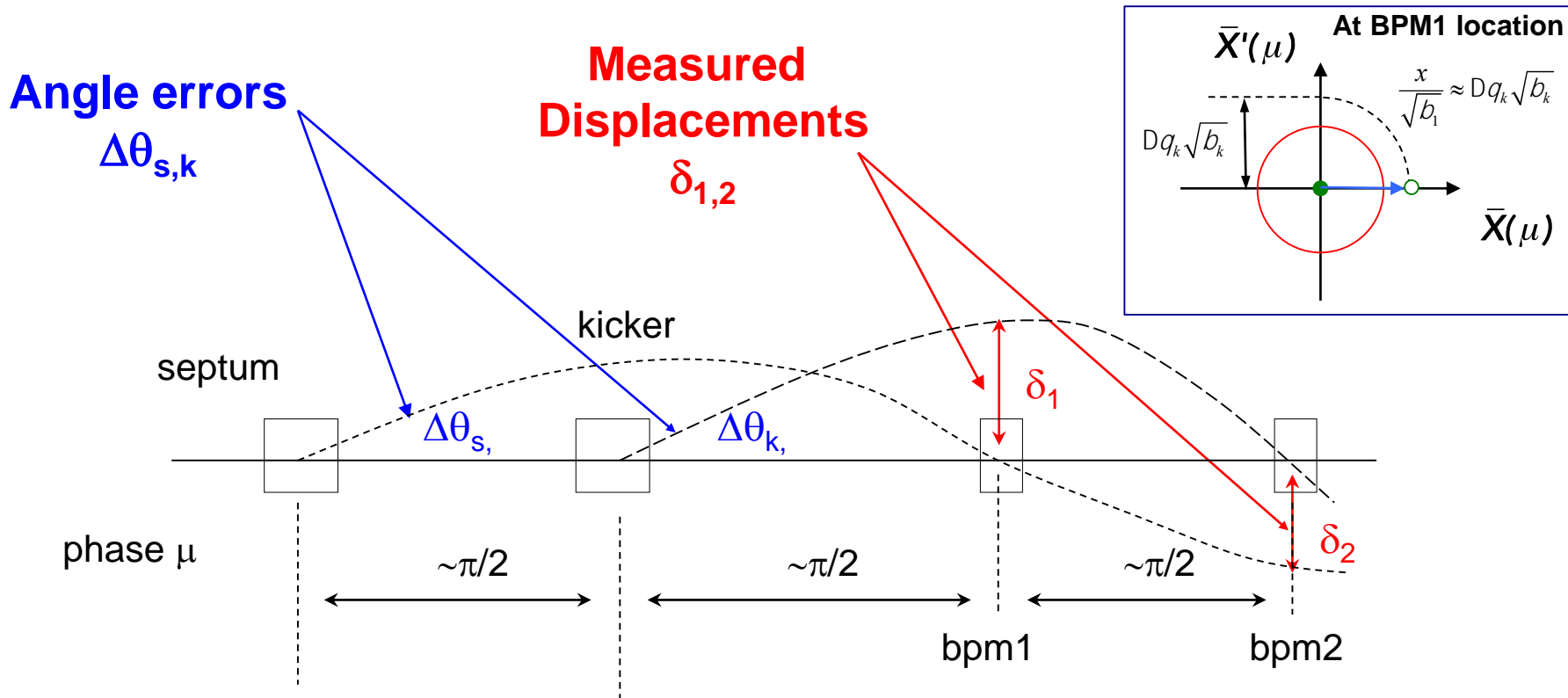

$$\delta_1 = \Delta\theta_s \sqrt{(\beta_s\beta_1)} \sin(\mu_1 - \mu_s) + \Delta\theta_k \sqrt{(\beta_k\beta_1)} \sin(\mu_1 - \mu_k)$$

$$\approx \Delta\theta_k \sqrt{(\beta_k\beta_1)}$$

$$\delta_2 = \Delta\theta_s \sqrt{(\beta_s\beta_2)} \sin(\mu_2 - \mu_s) + \Delta\theta_k \sqrt{(\beta_k\beta_2)} \sin(\mu_2 - \mu_k)$$

$$\approx -\Delta\theta_s \sqrt{(\beta_s\beta_2)}$$

Blow-up from steering error

- The new particle coordinates in normalised phase space are:

$$\bar{X}_{error} = \bar{X}_0 + L \cos q$$

$$\bar{X}'_{error} = \bar{X}'_0 + L \sin q$$

- For a general particle distribution, where A_i denotes amplitude in normalised phase of particle i :

$$\mathbf{A}_i^2 = \bar{X}_{0,i}^2 + \bar{X}'_{0,i}^2$$

- The emittance of the distribution is:

$$\mathcal{E}_{matched} = \langle \mathbf{A}_i^2 \rangle / 2$$

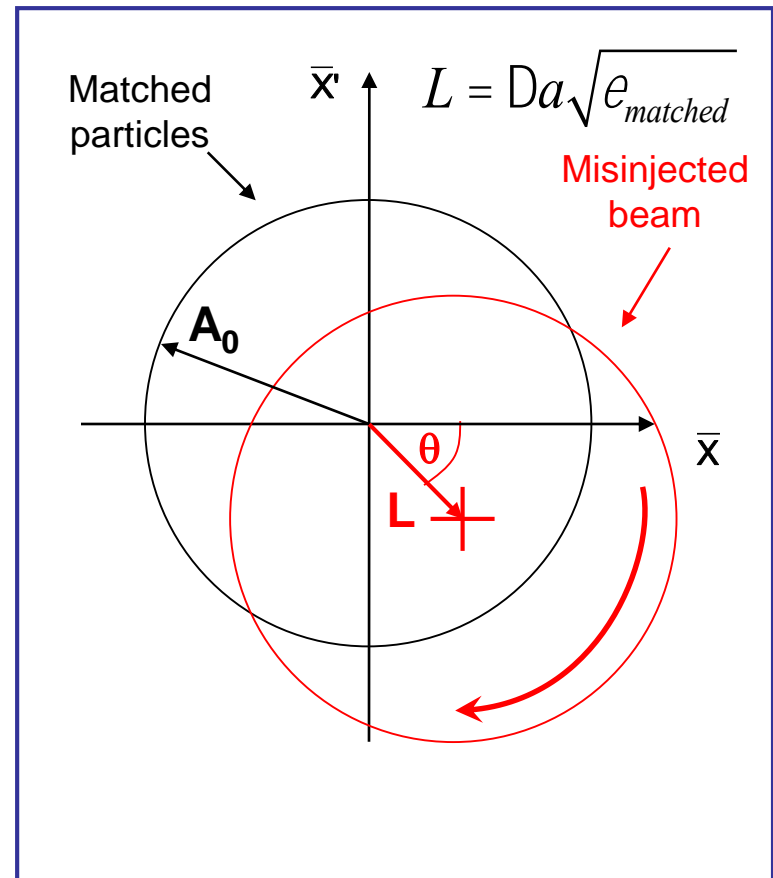

Blow-up from steering error

- So we plug in the new coordinates:

$$\begin{aligned}
 \mathbf{A}_{error}^2 &= \bar{X}_{error}^2 + \bar{X}'_{error}{}^2 \\
 &= (\bar{X}_0 + L \cos q)^2 + (\bar{X}'_0 + L \sin q)^2 \\
 &= \bar{X}_0^2 + \bar{X}'_0{}^2 + 2L(\bar{X}_0 \cos q + \bar{X}'_0 \sin q) + L^2
 \end{aligned}$$

$\cos^2 q + \sin^2 q = 1$

- Taking the average over distribution:

$$\begin{aligned}
 \langle \mathbf{A}_{error}^2 \rangle &= \langle \mathbf{A}_0^2 \rangle + 2L(\langle \bar{X}_0 \cos \theta \rangle + \langle \bar{X}'_0 \sin \theta \rangle) + \langle L^2 \rangle \\
 &= 2e_{matched} + L^2
 \end{aligned}$$

- Giving the diluted emittance as:

$$\begin{aligned}
 e_{diluted} &= e_{matched} + \frac{L^2}{2} \\
 &= e_{matched} \left[1 + \frac{Da^2}{2} \right]
 \end{aligned}$$

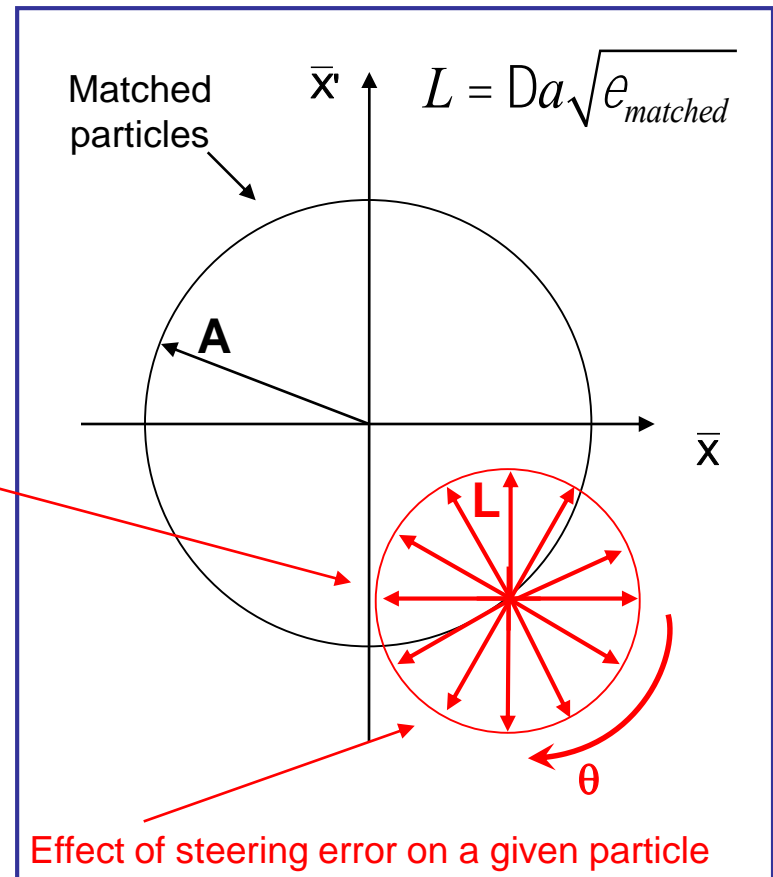

Blow-up from steering error

- Consider a collection of particles with max. amplitudes A
- The beam can be injected with an error in angle and position
- For an injection error Δa , in units of $\sigma = \sqrt{\beta\varepsilon}$, the mis-injected beam is offset in normalised phase space by an amplitude $L = \Delta a\sqrt{\varepsilon}$

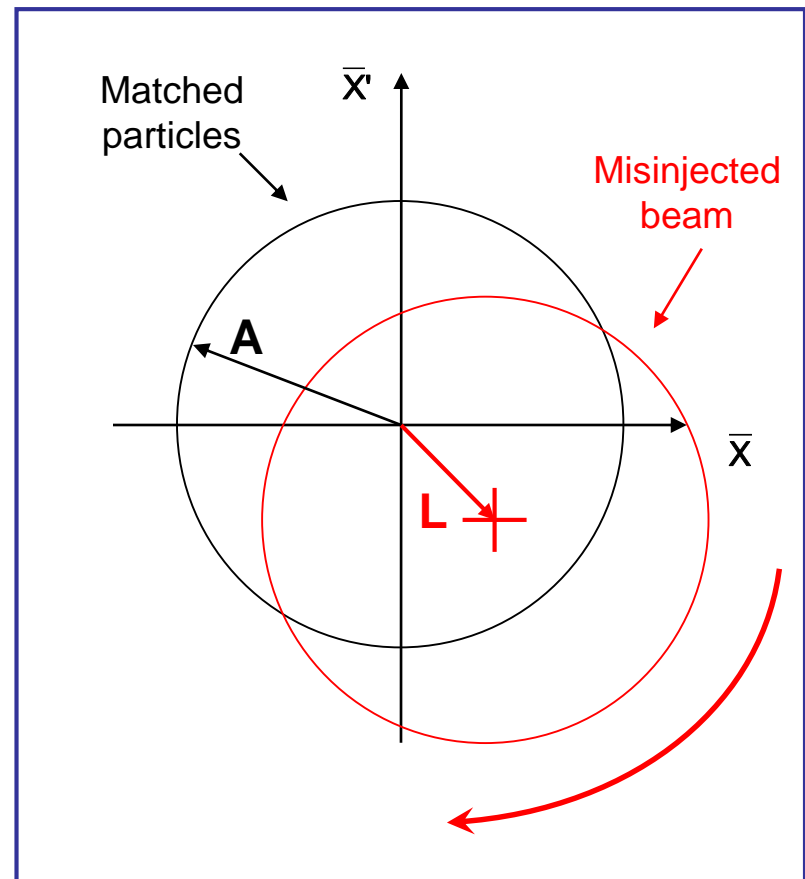

Blow-up from steering error

- Consider a collection of particles with max. amplitudes A
- The beam can be injected with an error in angle and position.
- For an injection error Δa , in units of $\sigma = \sqrt{\beta\varepsilon}$, the mis-injected beam is offset in normalised phase space by an amplitude $L = \Delta a\sqrt{\varepsilon}$

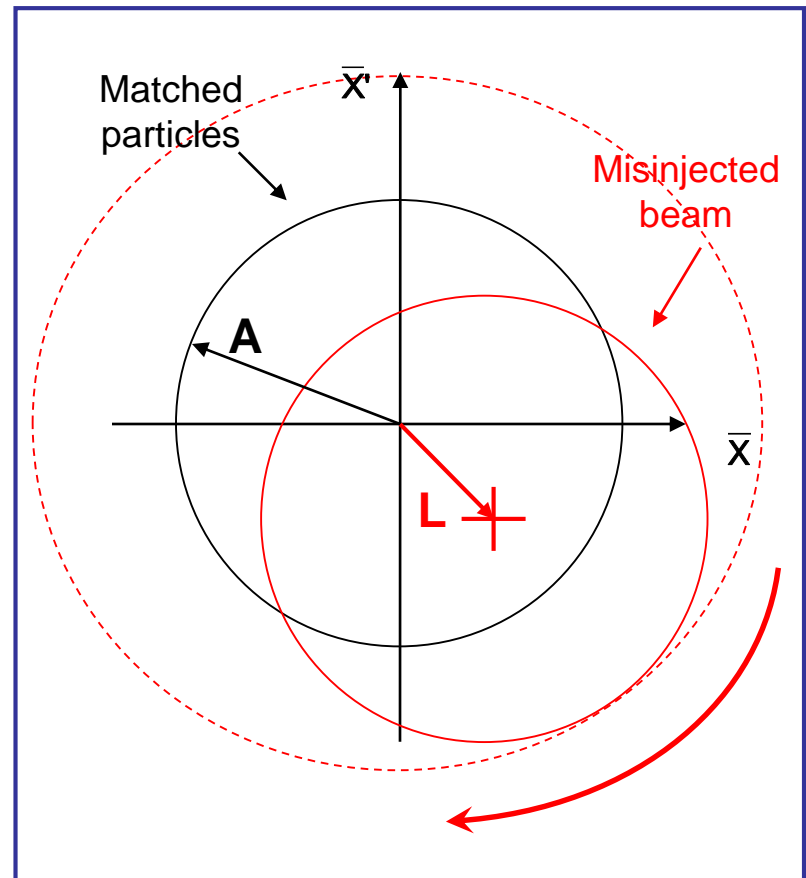

Blow-up from steering error

- Consider a collection of particles with max. amplitudes A
- The beam can be injected with an error in angle and position.
- For an injection error Δa , in units of $\sigma = \sqrt{\beta\varepsilon}$, the mis-injected beam is offset in normalised phase space by an amplitude $L = \Delta a\sqrt{\varepsilon}$

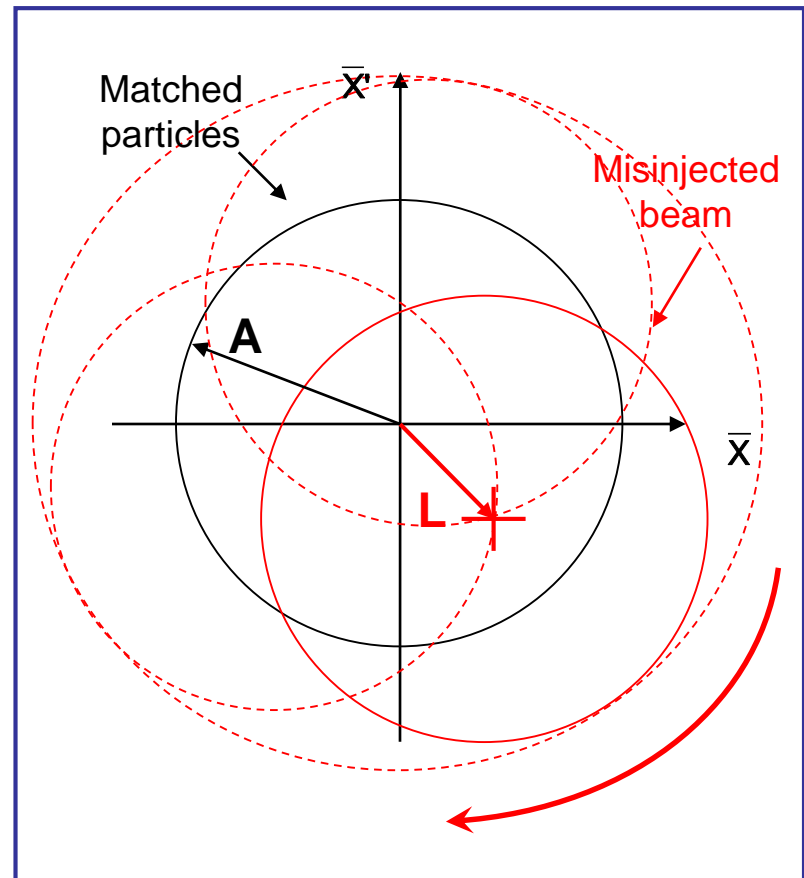

Blow-up from steering error

- Consider a collection of particles with max. amplitudes A
- The beam can be injected with an error in angle and position.
- For an injection error Δa , in units of $\sigma = \sqrt{\beta\varepsilon}$, the mis-injected beam is offset in normalised phase space by an amplitude $L = \Delta a\sqrt{\varepsilon}$
- Any given point on the matched ellipse is randomised over all phases after filamentation due to the steering error:

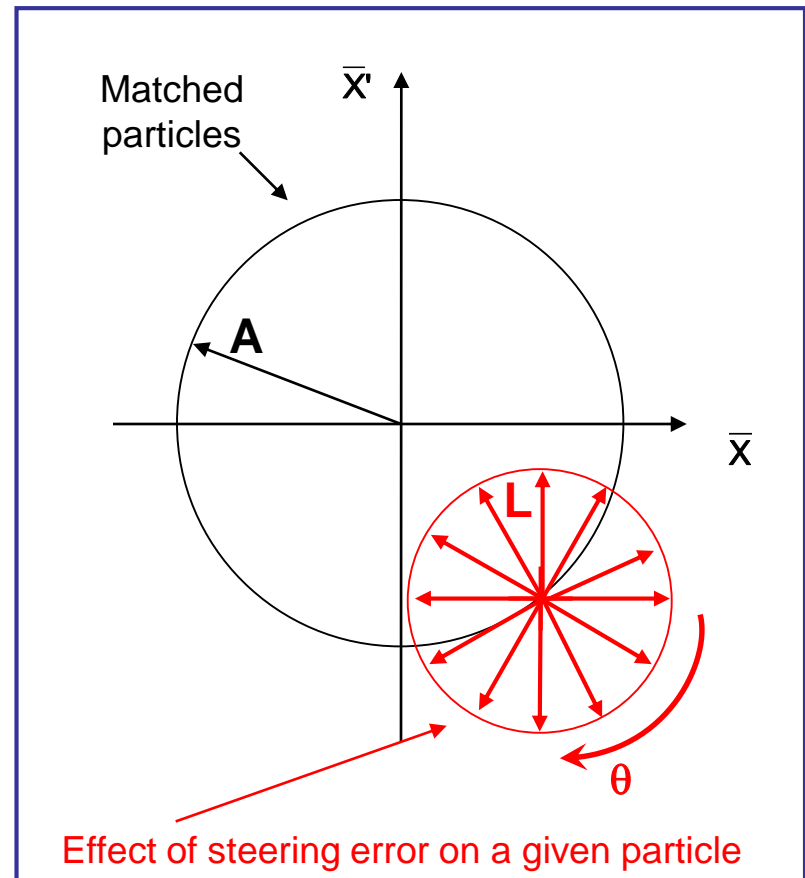

Blow-up from steering error

- Consider a collection of particles with max. amplitudes A
- The beam can be injected with an error in angle and position.
- For an injection error Δa , in units of $\sigma = \sqrt{(\beta\varepsilon)}$, the mis-injected beam is offset in normalised phase space by an amplitude $L = \Delta a\sqrt{\varepsilon}$
- Any given point on the matched ellipse is randomised over all phases after filamentation due to the steering error
- For a general particle distribution, where A_i denotes amplitude in normalised phase of particle i :

$$\varepsilon_{matched} = \langle A_i^2 \rangle / 2$$

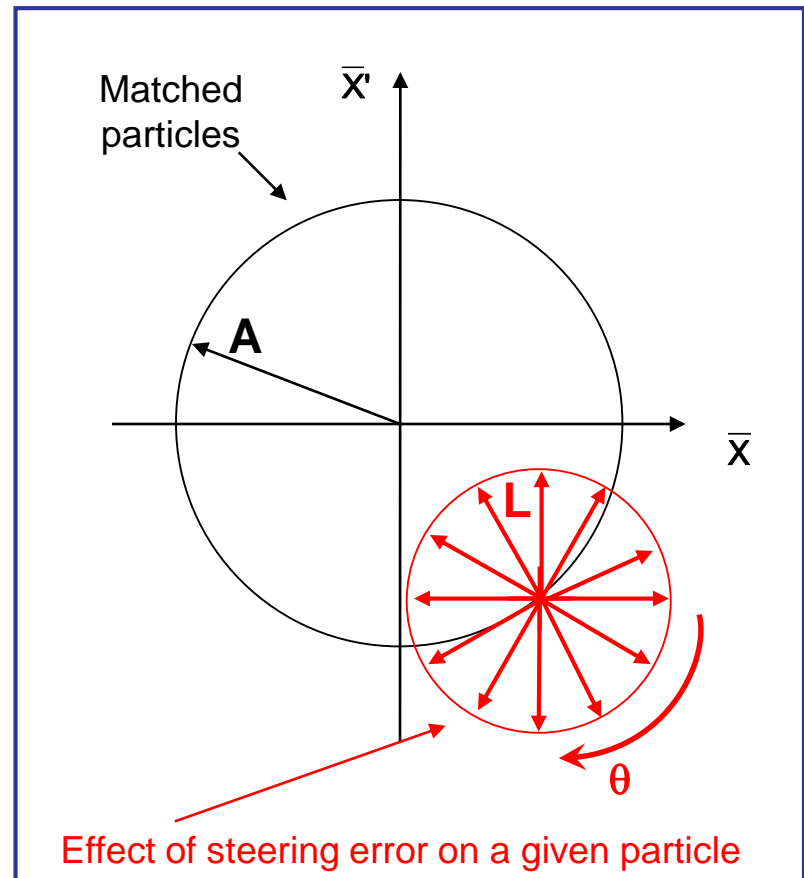

Blow-up from steering error

- Consider a collection of particles with max. amplitudes A
- The beam can be injected with an error in angle and position.
- For an injection error Δa , in units of $\sigma = \sqrt{(\beta\varepsilon)}$, the mis-injected beam is offset in normalised phase space by an amplitude $L = \Delta a\sqrt{\varepsilon}$
- Any given point on the matched ellipse is randomised over all phases after filamentation due to the steering error
- For a general particle distribution, where A_i denotes amplitude in normalised phase of particle i :

$$\varepsilon_{matched} = \langle \mathbf{A}_i^2 \rangle / 2$$

- After filamentation:

$$\varepsilon_{diluted} = \varepsilon_{matched} + \frac{L^2}{2}$$

See appendix for derivation

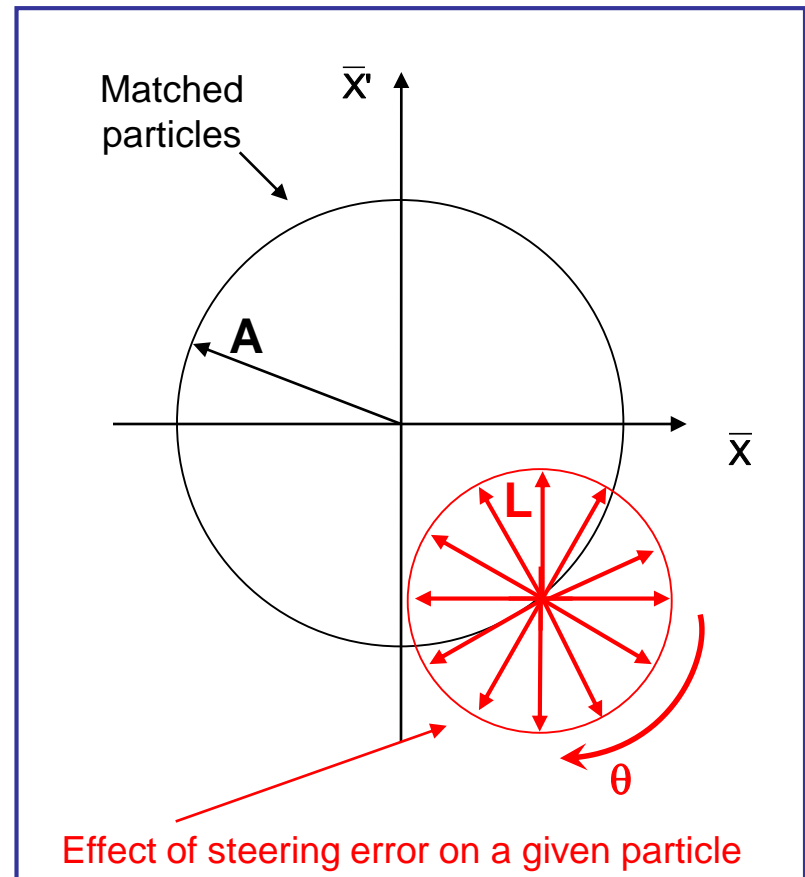

Blow-up from steering error

- A numerical example....

- Consider an offset $\Delta a = 0.5\sigma$ for injected beam:

$$L = Da\sqrt{e_{matched}}$$

$$\begin{aligned}e_{diluted} &= e_{matched} + \frac{L^2}{2} \\ &= e_{matched} \left[1 + \frac{Da^2}{2} \right] \\ &= e_{matched} [1.125]\end{aligned}$$

- For nominal LHC beam:

...allowed growth through LHC cycle $\sim 10\%$

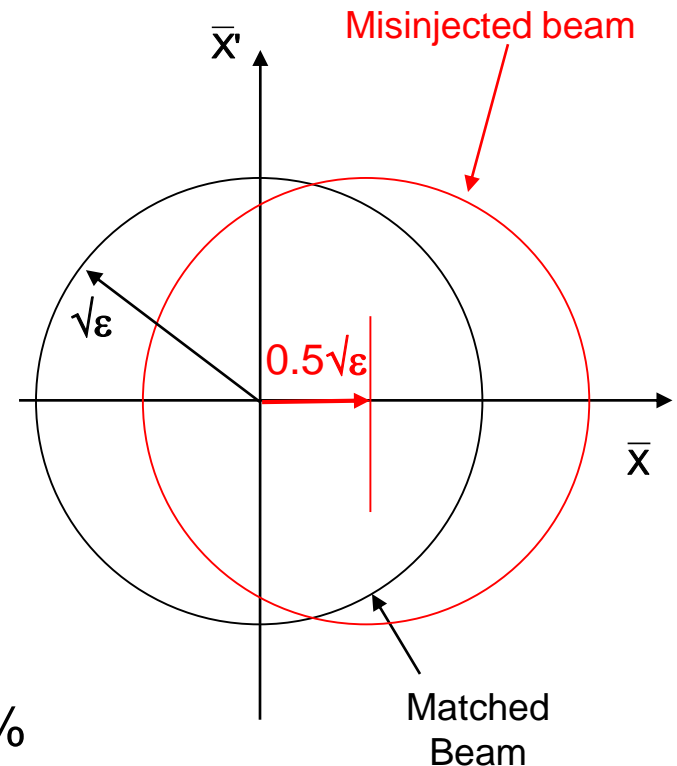

Third-order resonant extraction

- On resonance, sextupole kicks add-up driving particles over septum

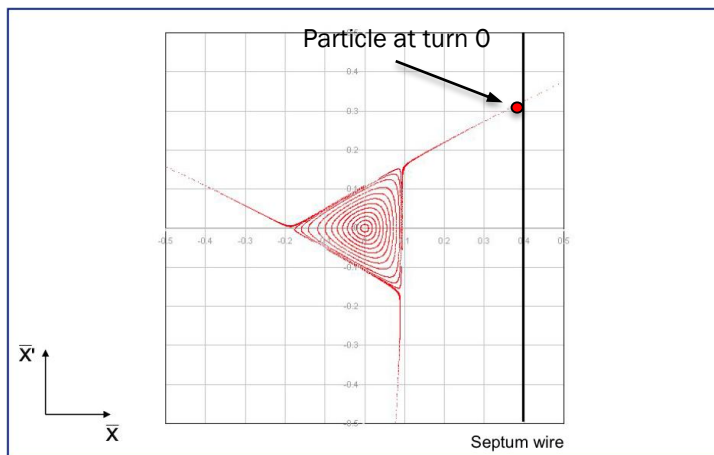

Third-order resonant extraction

- On resonance, sextupole kicks add-up driving particles over septum

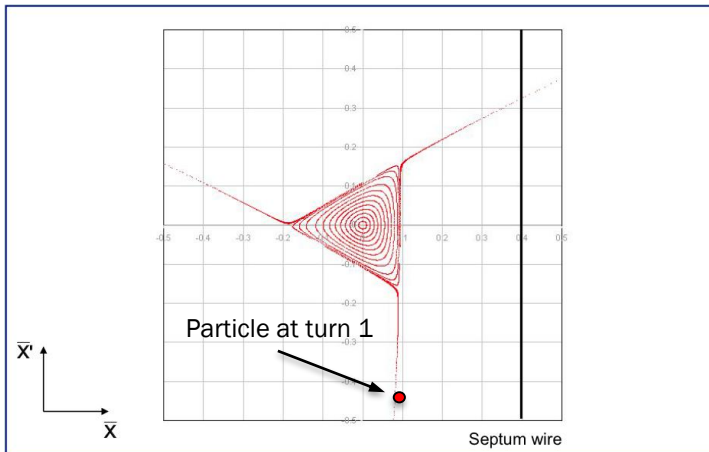

Third-order resonant extraction

- On resonance, sextupole kicks add-up driving particles over septum

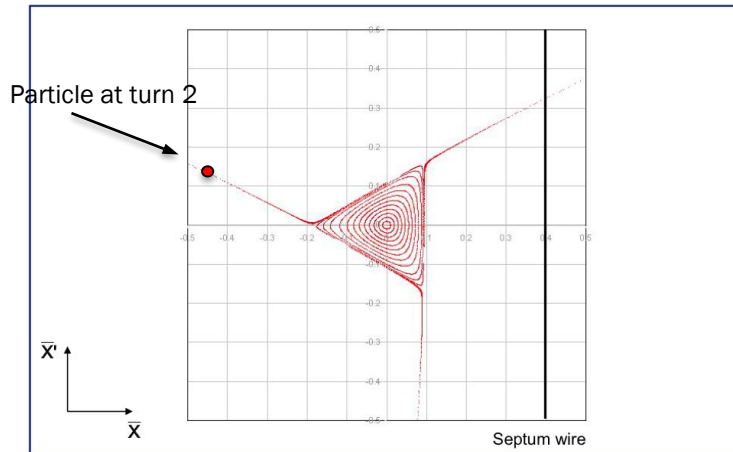

Third-order resonant extraction

- On resonance, sextupole kicks add-up driving particles over septum

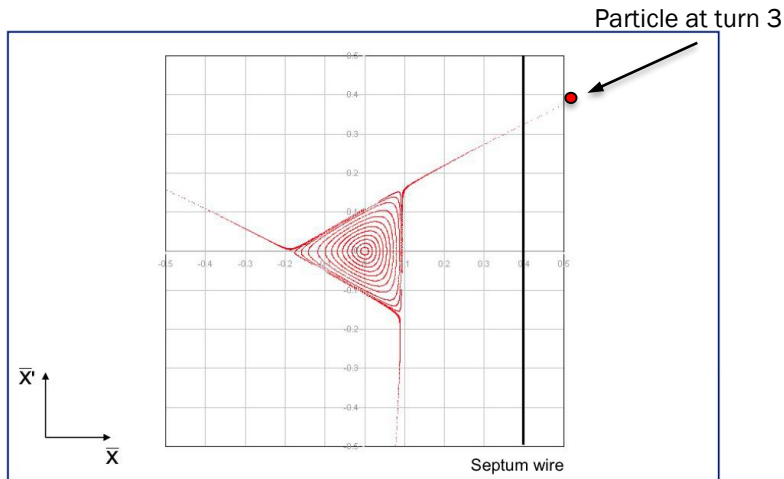

Third-order resonant extraction

- On resonance, sextupole kicks add-up driving particles over septum
 - Distance travelled in these final three turns is termed the “spiral step,” ΔX_{ES}
 - Extraction bump trimmed in the machine to adjust the spiral step

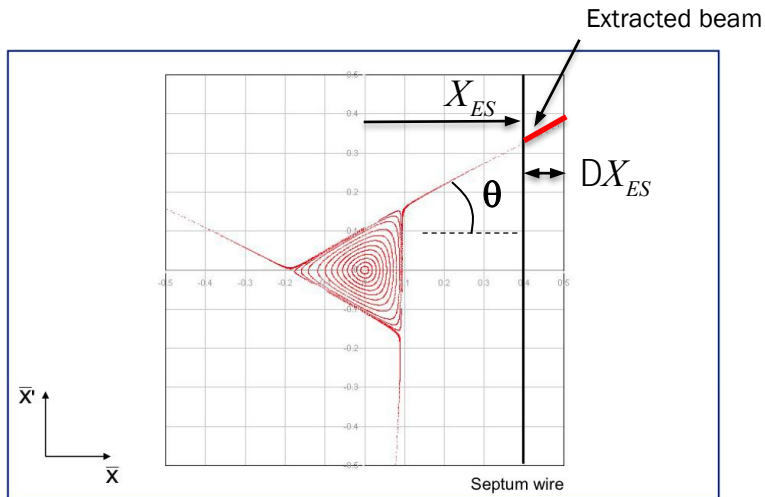

$$\Delta X_{ES} \propto |k_2| \frac{X_{ES}^2}{\cos q}$$

Third-order resonant extraction

- On resonance, sextupole kicks add-up driving particles over septum
 - Distance travelled in these final three turns is termed the “spiral step,” ΔX_{ES}
 - Extraction bump trimmed in the machine to adjust the spiral step

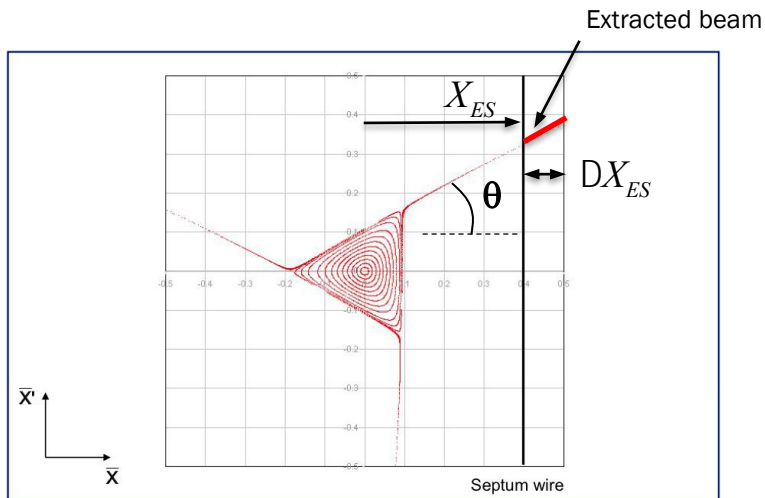

$$DX_{ES} \propto |k_2| \frac{X_{ES}^2}{\cos q}$$

momentum spread, tune $\frac{Dp}{p} \propto -DQ$

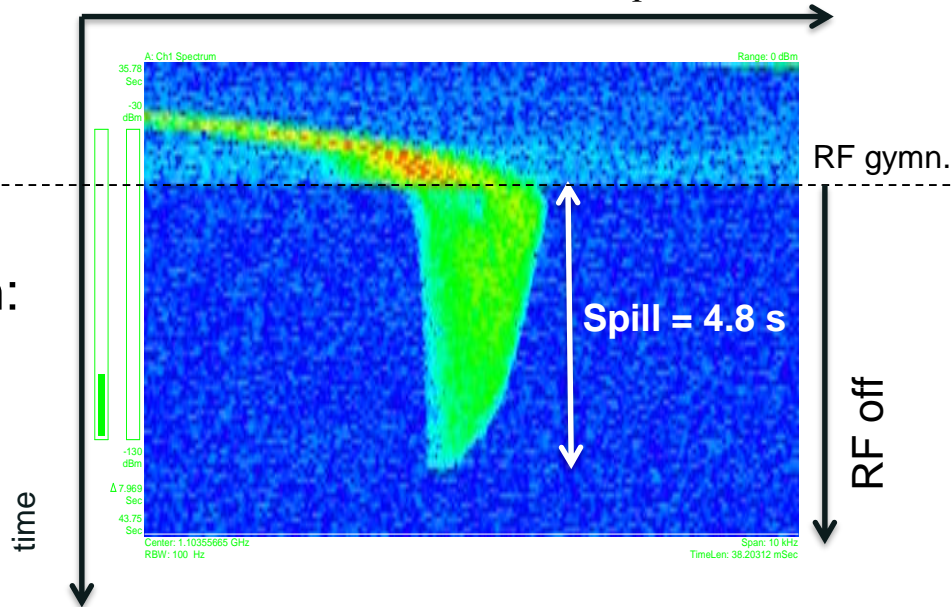

- RF gymnastics before extraction:

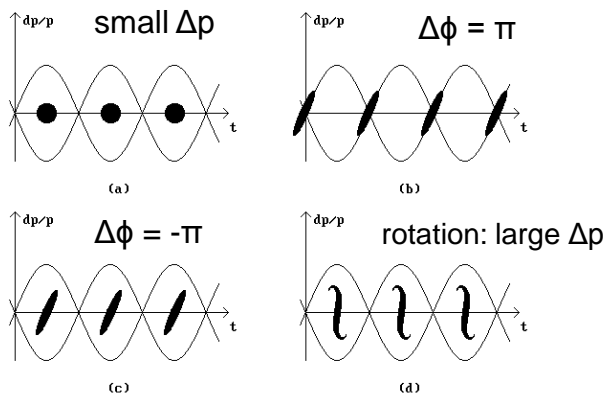

Schottky measurement during spill, courtesy of T. Bohl

Slow extraction channel: SPS

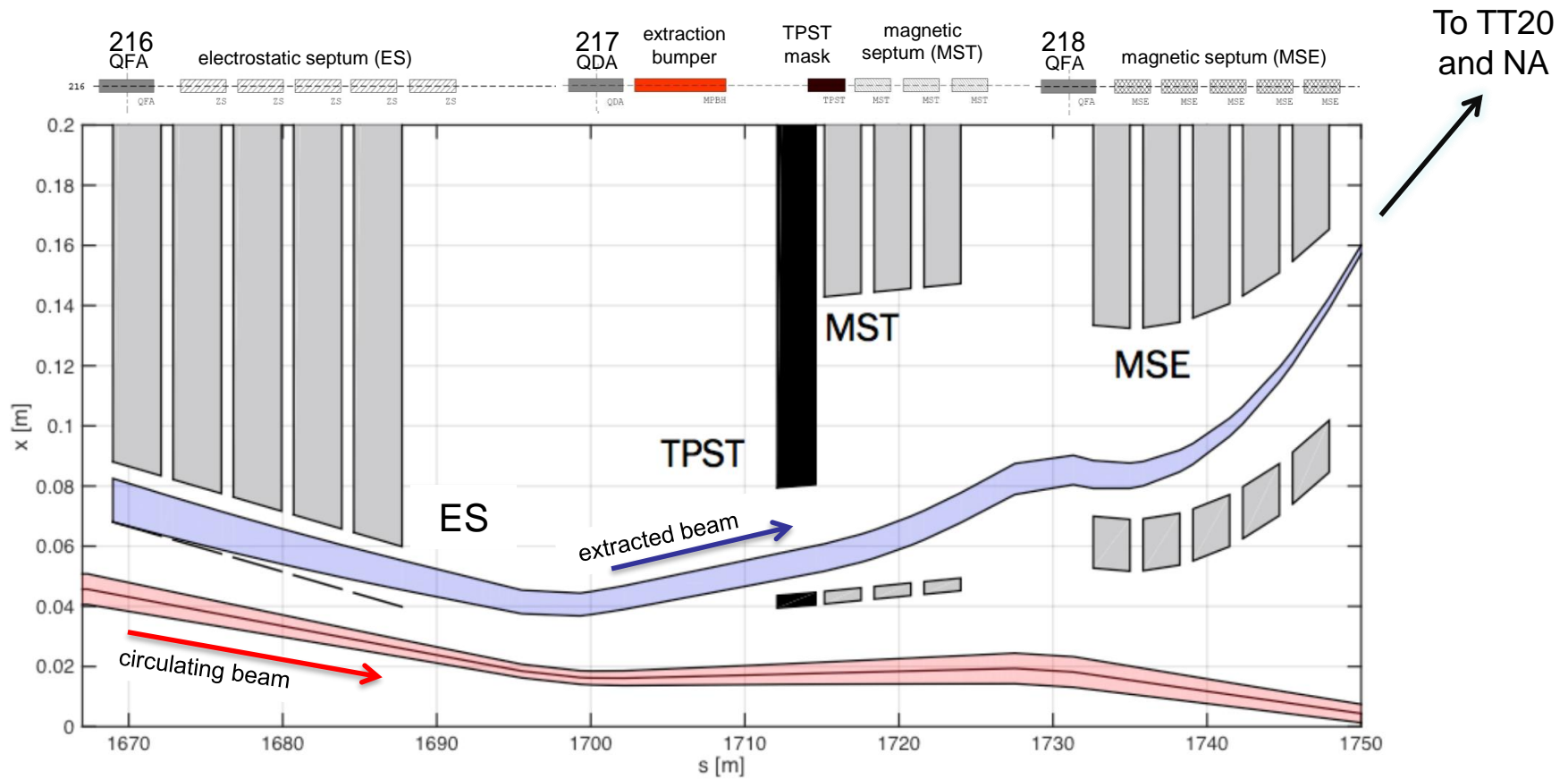

Second-order resonant extraction

- An extraction can also be made over a few hundred turns
- 2nd and 4th order resonances
 - Octupole fields distort the regular phase space particle trajectories
 - Stable area defined, delimited by two unstable Fixed Points
 - Beam tune brought across a 2nd order resonance ($Q \rightarrow 0.5$)
 - Particle amplitudes quickly grow and beam is extracted in a few hundred turns

Resonant extraction separatrixes

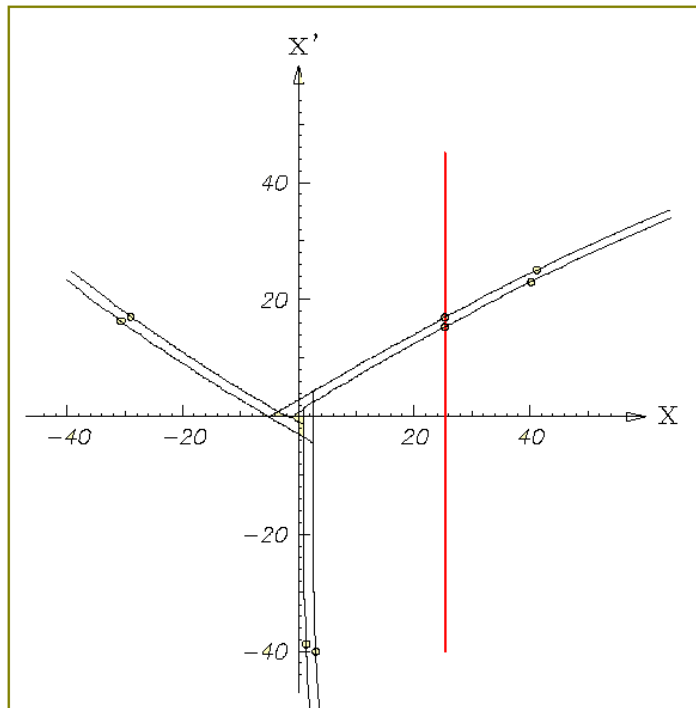

\bar{X}' 3rd order resonant extraction

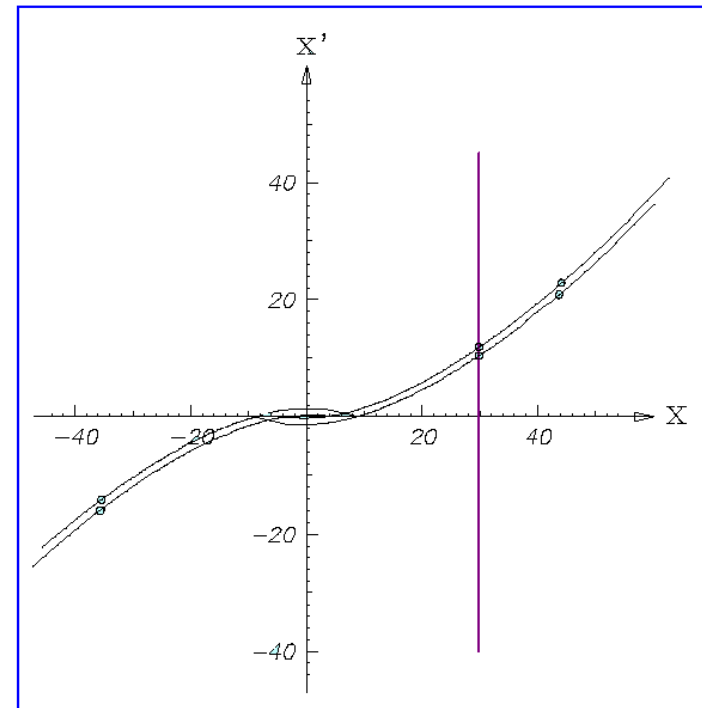
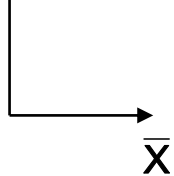

2nd order resonant extraction

- Amplitude growth for 2nd order resonance much faster than 3rd – shorter spills (\approx milliseconds vs. seconds)
- Used where intense pulses are required on target – e.g. neutrino production

Simplified kicker system schematic

$t = 0$

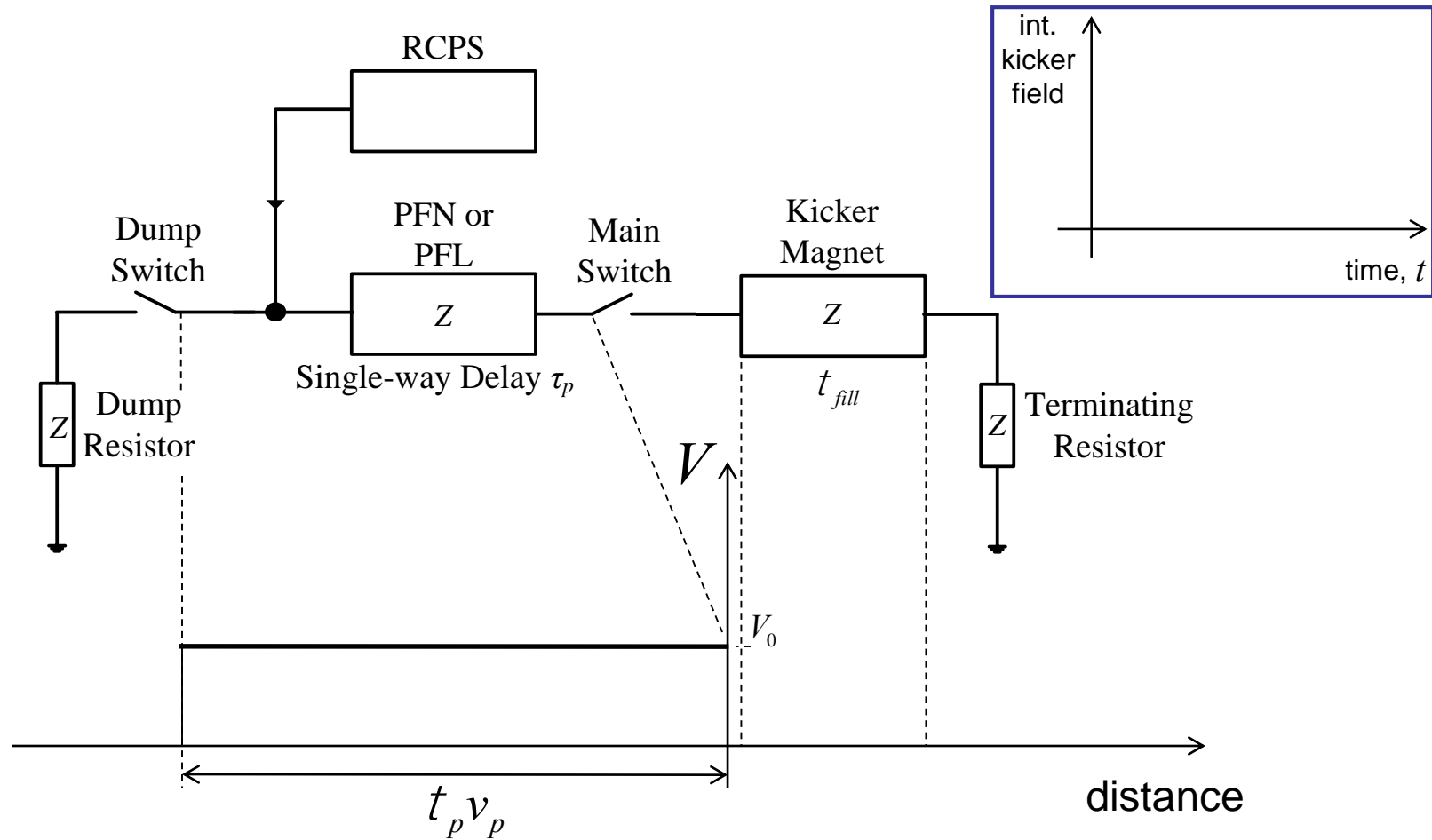

- Pulse forming network or line (PFL/PFN) charged to voltage V_0 by the resonant charging power supply (RCPS)
 - RCPS is de-coupled from the system through a diode stack

Simplified kicker system schematic

$t \gg 0$

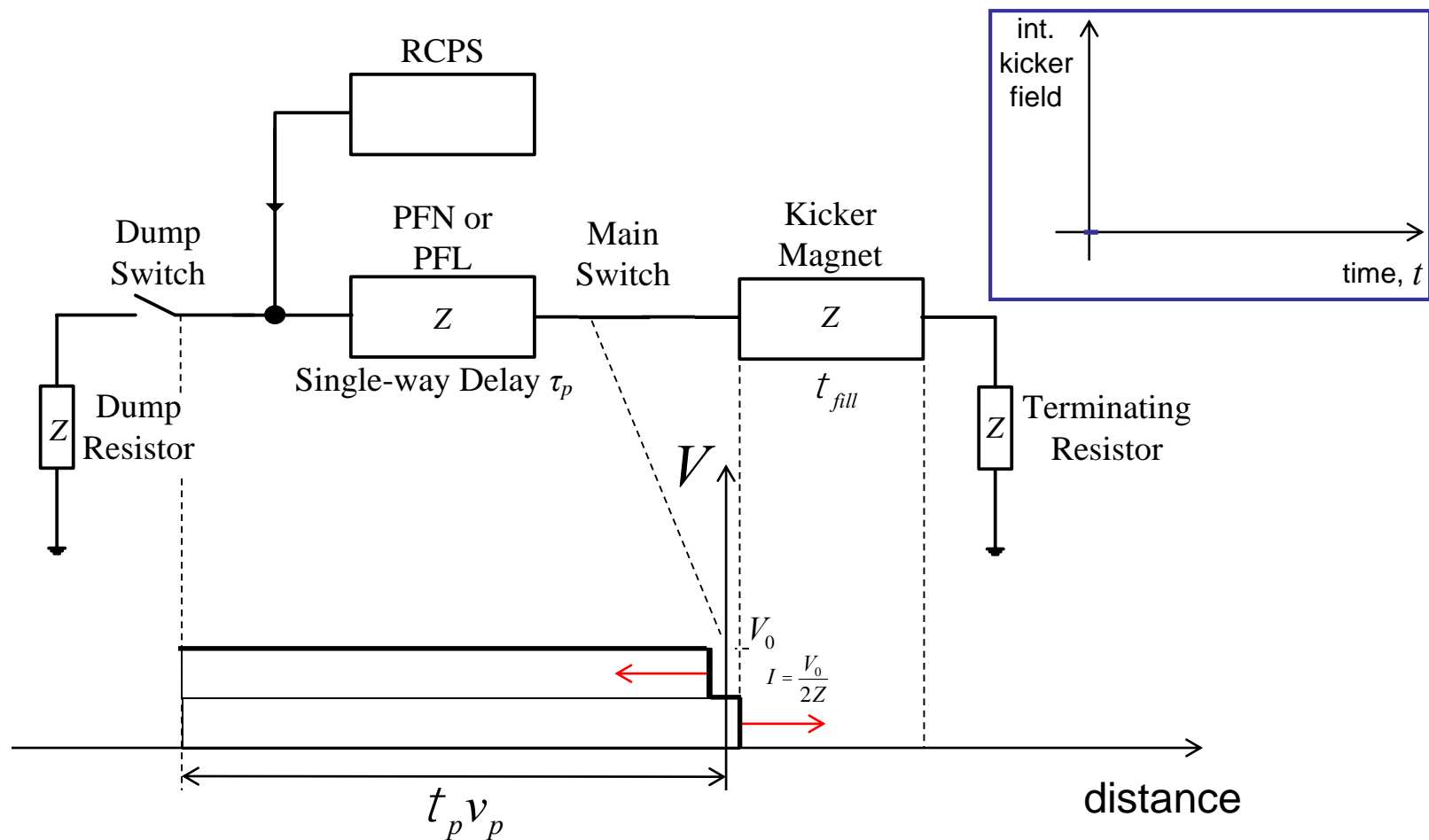

- Pulse forming network or line (PFL/PFN) charged to voltage V_0 by the resonant charging power supply (RCPS)
 - RCPS is de-coupled from the system through a diode stack
- At $t = 0$, main switch is closed and current starts to flow into the kicker

Simplified kicker system schematic

$$t \gg t_{fill}$$

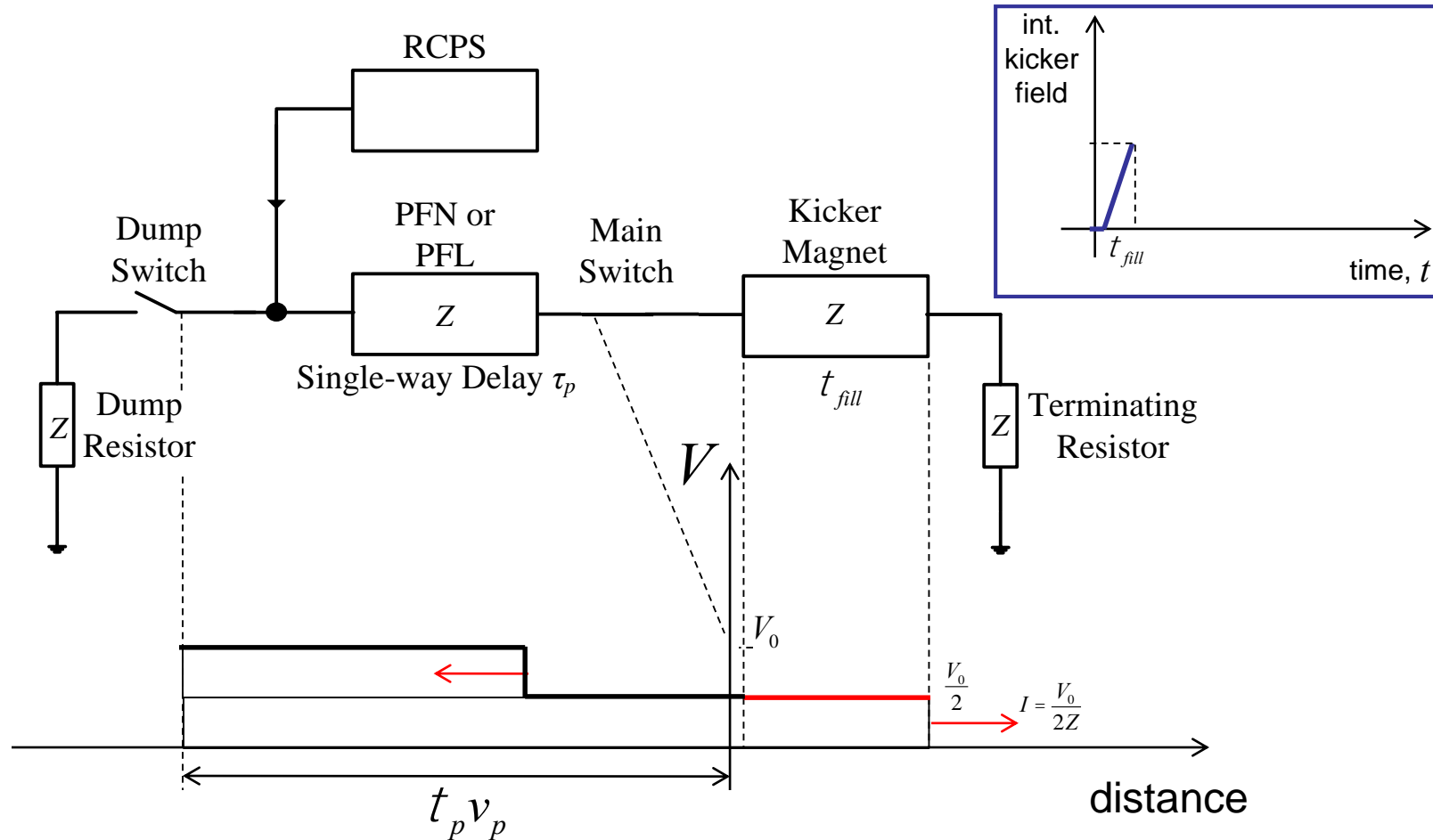

- At $t = t_{fill}$, the voltage pulse of magnitude $V_0/2$ has propagated through the kicker and nominal field achieved with a current $V_0/2Z$
 - typically $t_p \gg t_{fill}$ (schematic for illustration purposes)

Simplified kicker system schematic

$$t \gg t_p$$

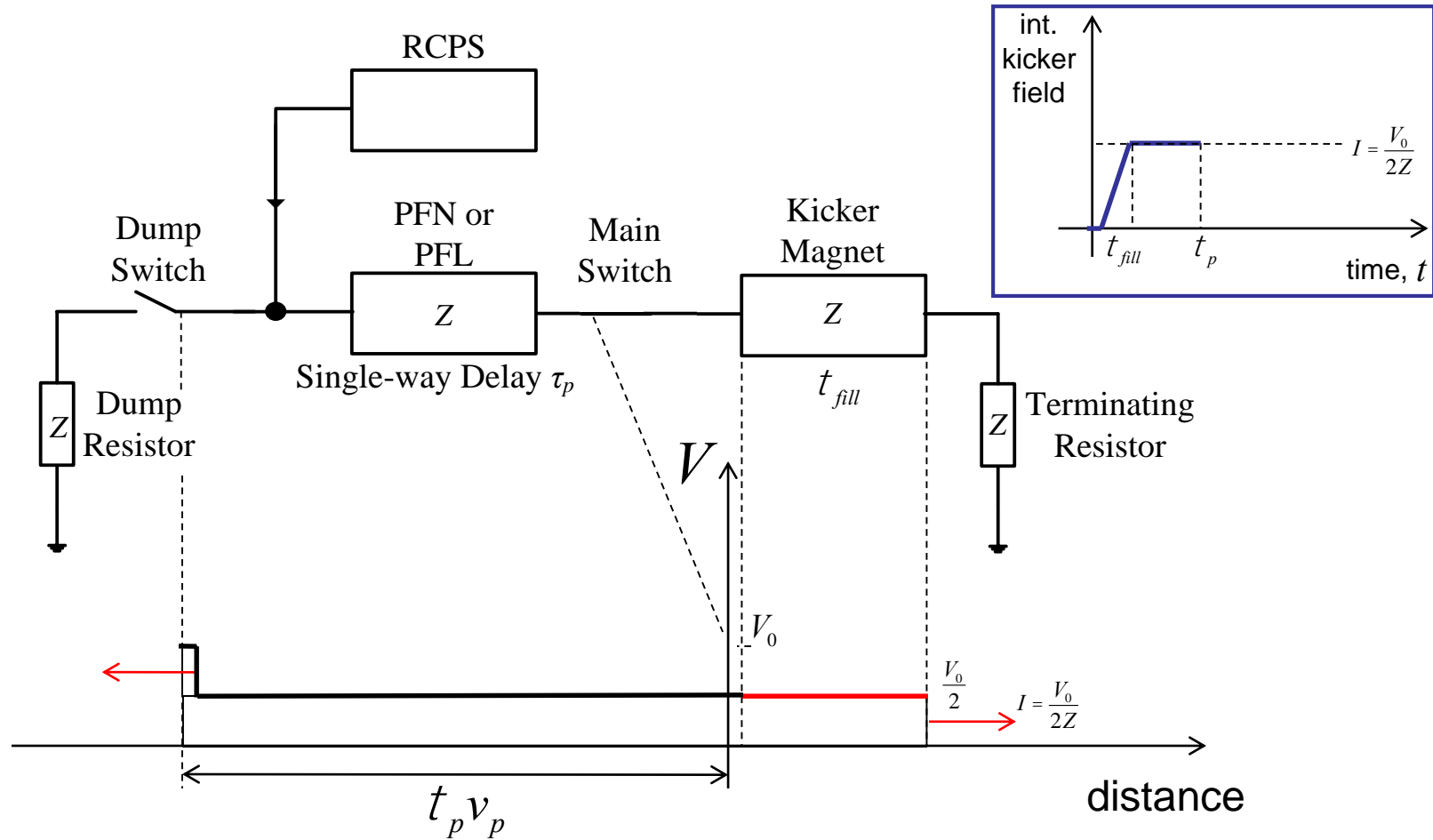

- PFN continues to discharge energy into kicker magnet and matched terminating resistor

Simplified kicker system schematic

$$t \gg t_p$$

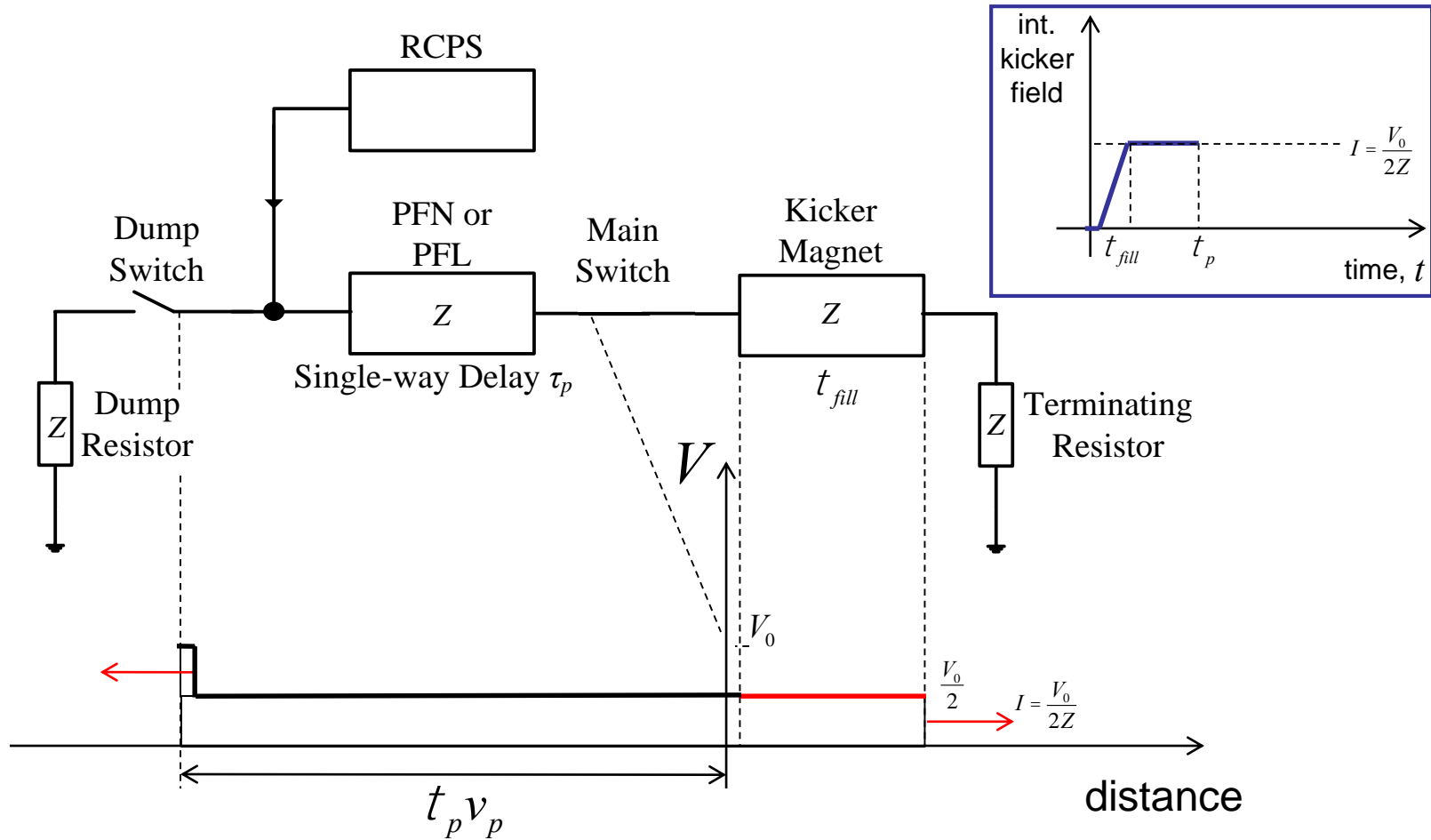

- PFN continues to discharge energy into kicker magnet and matched terminating resistor
- At $t \approx t_p$ the negative pulse reflects off the open end of the circuit (dump switch) and back towards the kicker

Simplified kicker system schematic

$$t \gg t_p$$

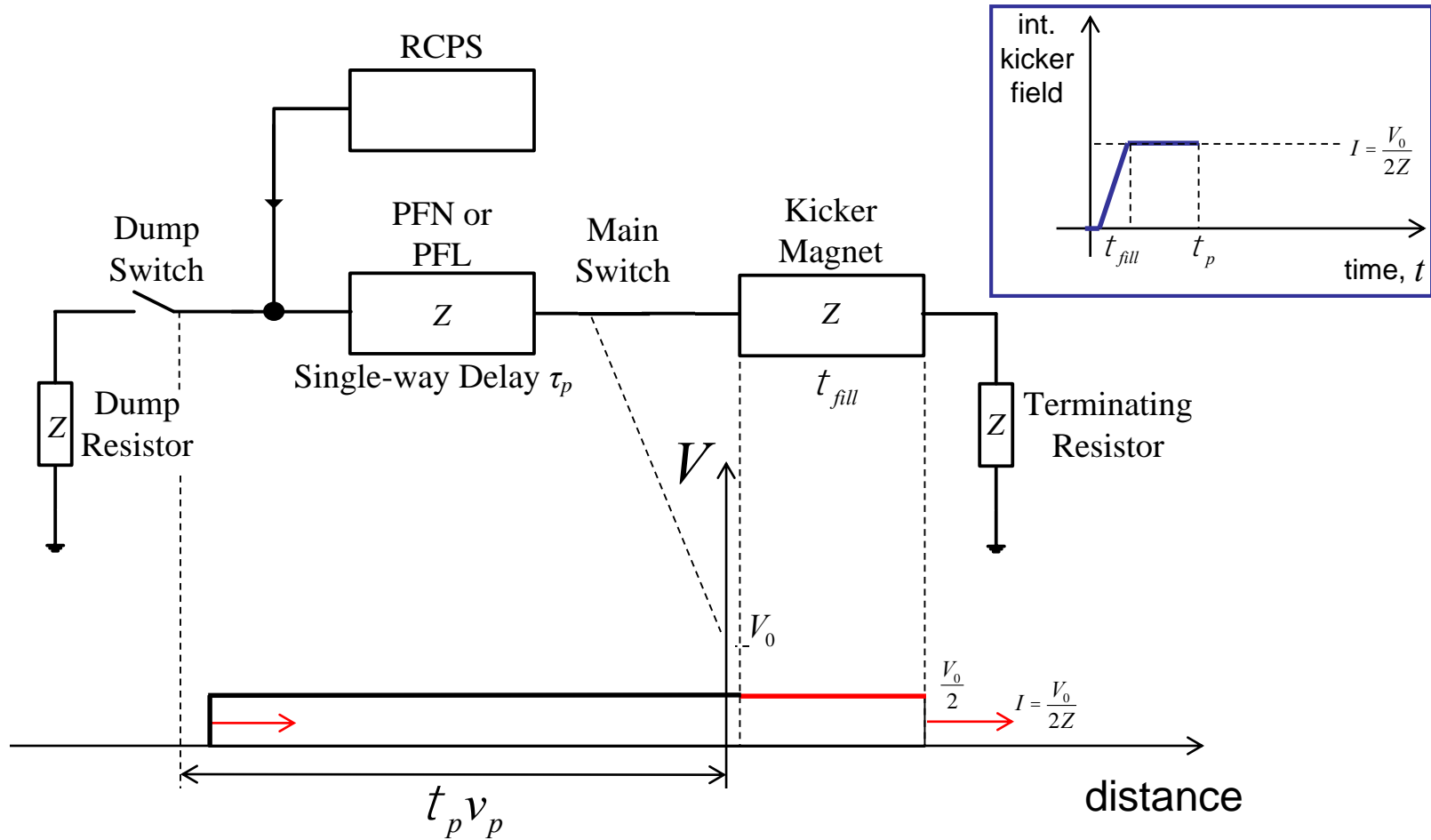

- PFN continues to discharge energy into matched terminating resistor
- At $t \approx t_p$ the negative pulse reflects off the open end of the circuit and back towards the kicker

Simplified kicker system schematic

$$t \gg 2t_p$$

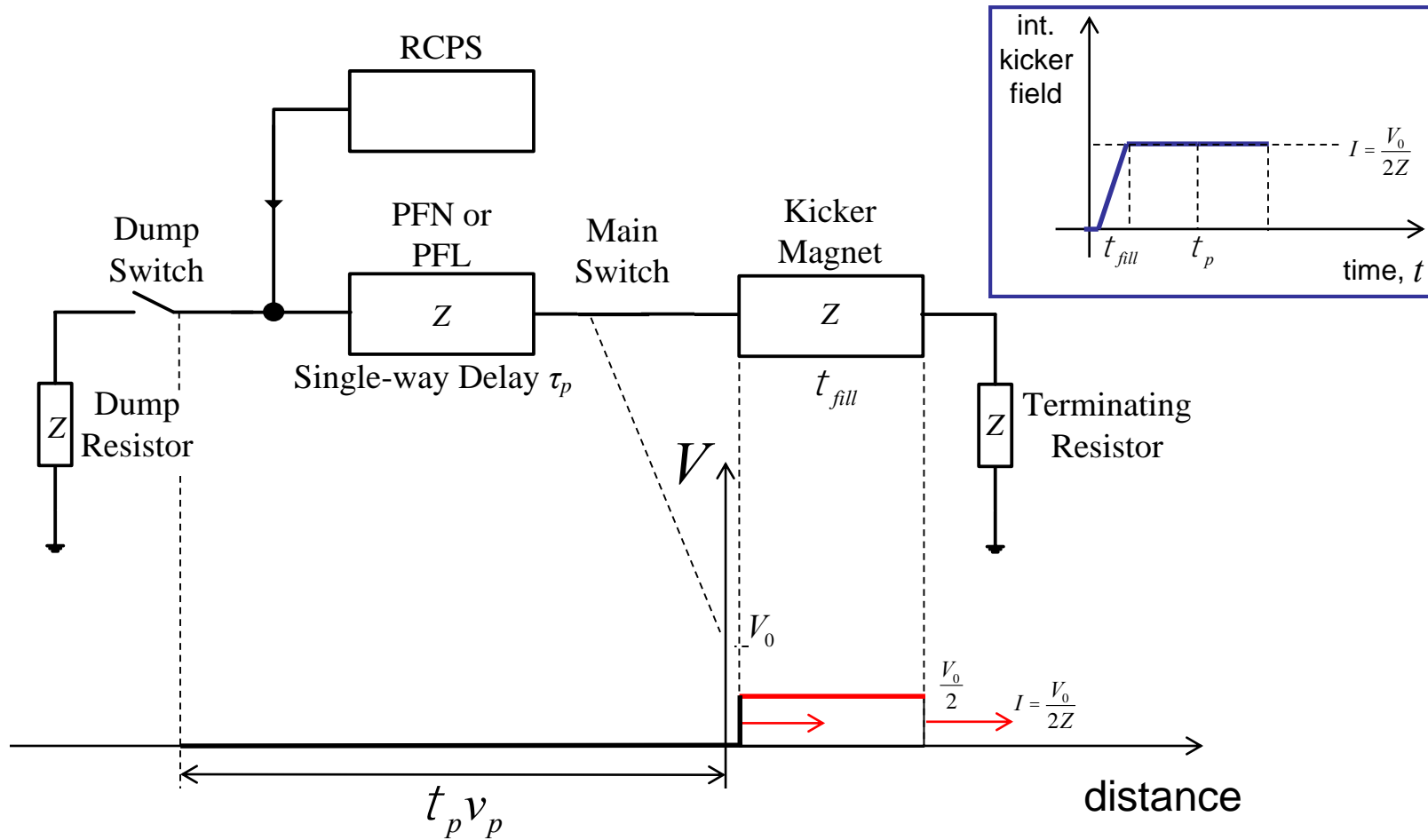

- At $t \approx 2t_p$ the pulse arrives at the kicker and field starts to decay

Simplified kicker system schematic

$$t = 2t_p + t_{fill}$$

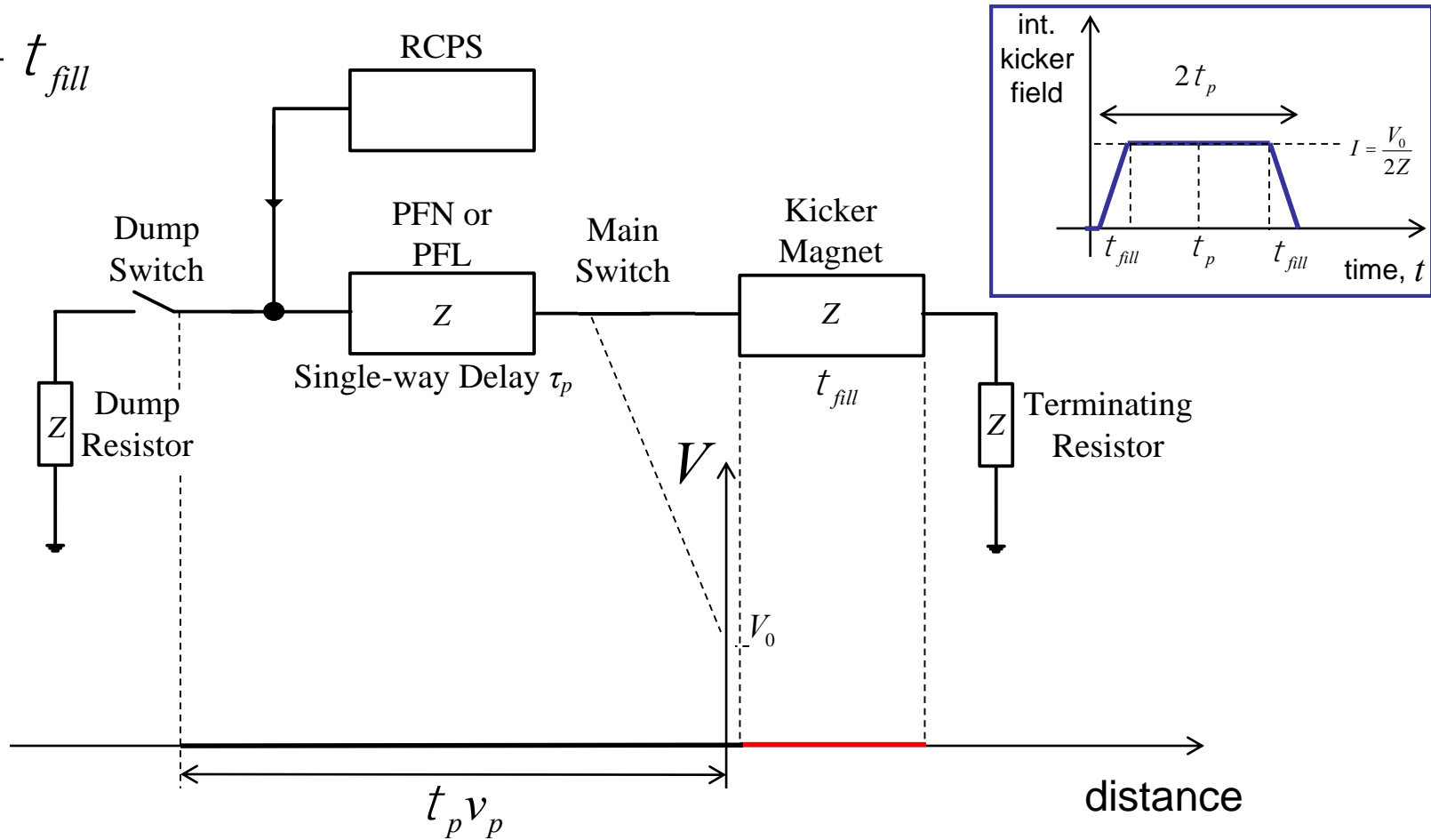

- A kicker pulse of approximately $2 \tau_p$ is imparted on the beam and all energy has been emptied into the terminating resistor

Simplified kicker system schematic

$$t \gg 2t_p$$

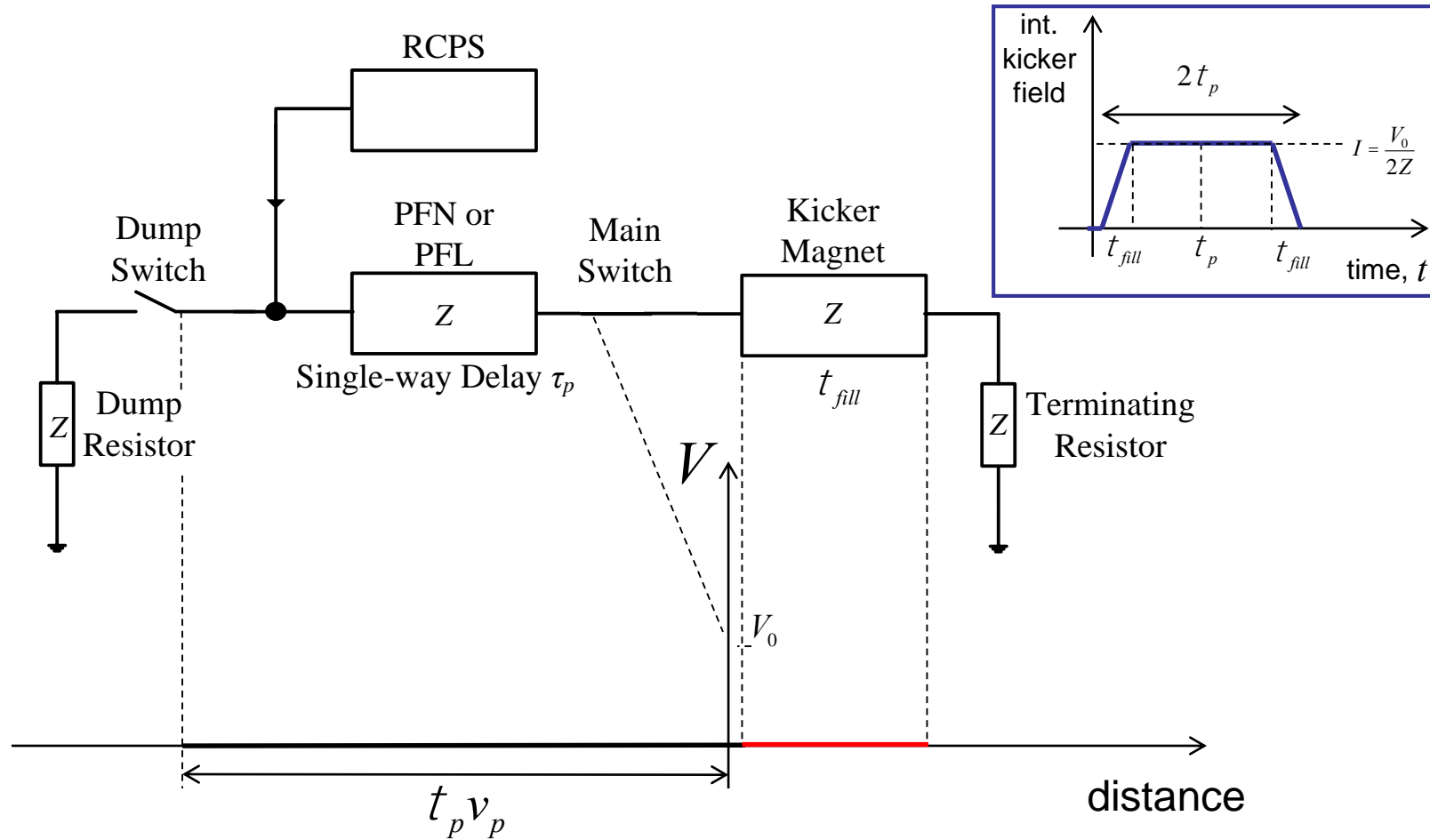

- Kicker pulse length can be changed by adjusting the relative timing of dump and main switches:
 - e.g. if the dump and main switches are fired simultaneously the pulse length will be halved and energy shared on dump and terminating resistors