



UPPSALA
UNIVERSITET

Imperfections and Correction

V. Ziemann

Uppsala University

What is this talk about?

- First, you come up with lattice and design optics
 - nice and shiny beta functions
 - high periodicity \rightarrow systematic errors cancel

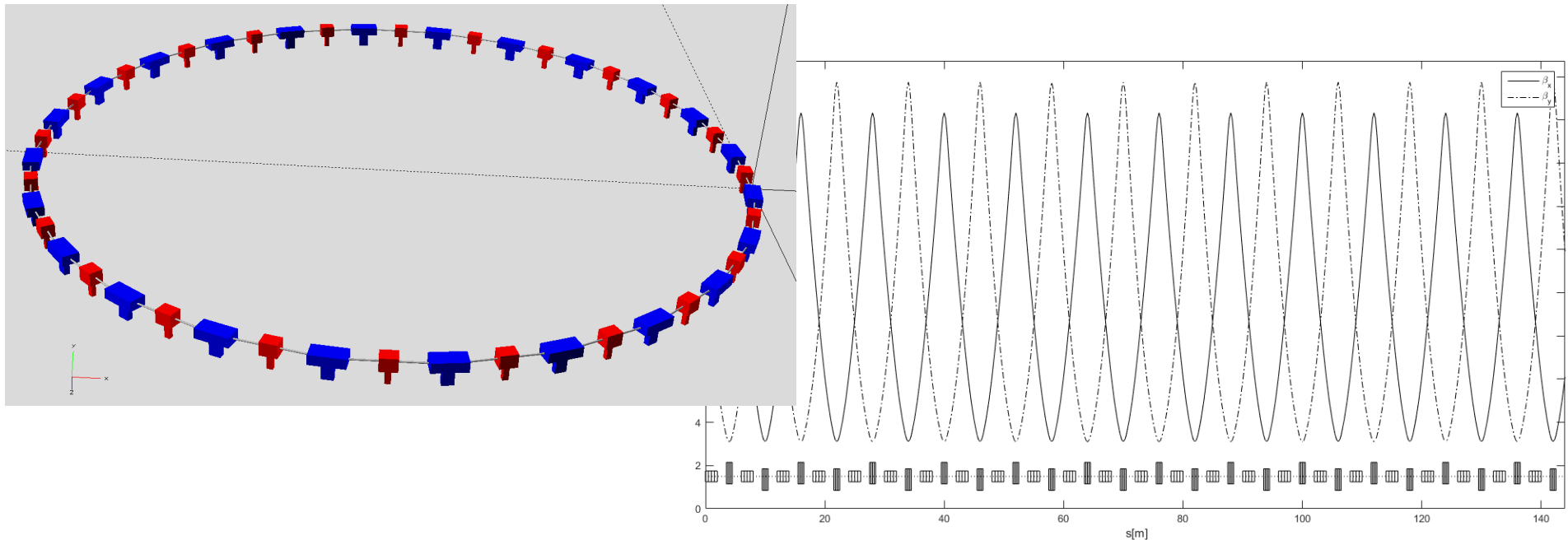



But then...

- ...the accelerator is built, and..
 - the magnets are not quite where they should be;
 - power supplies have calibration errors;
 - magnets have incorrect shims;
 - the diagnostics might have imperfections, too.
 - BPM
 - Screens



Therefore...

- I talk about
 - things that can go wrong (courtesy of Mrs Murphy...)
→ Imperfections
 - how to figure out what is wrong
→ Diagnostics to use
 - and fix it
→ Corrections



Outline

- Imperfections
- Straight systems
 - Beam lines and Linac
 - Imperfections and their corrections
- Rings
 - Imperfections and their corrections

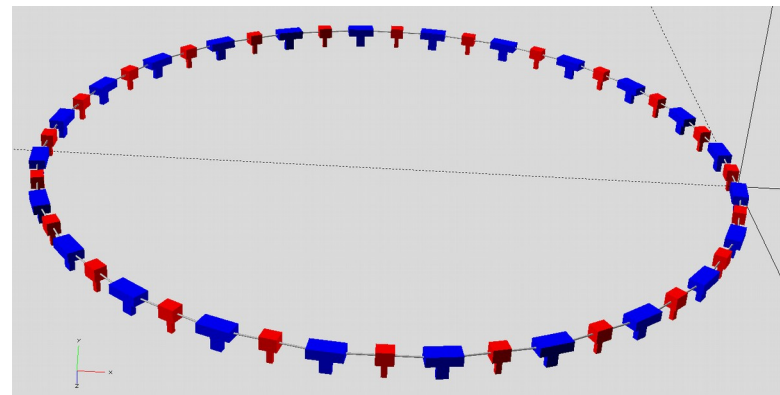
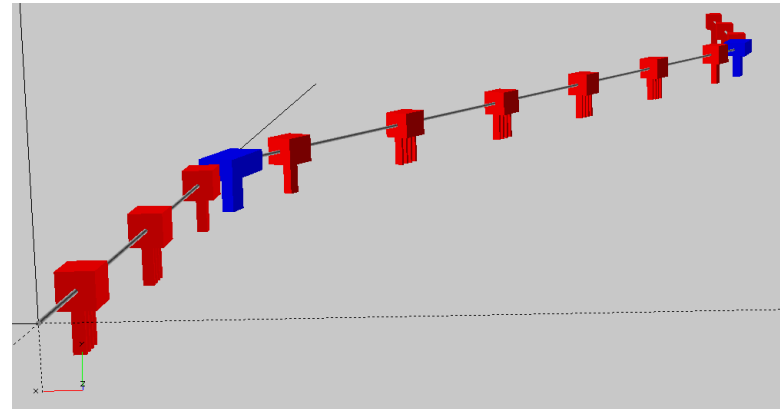



Part 1: Linear Imperfections

- Spoil the 'nice&shiny™' periodic magnet lattice
 - due to unwanted magnetic fields in the wrong place
- that's where the beam is
 - average: dipole kick
 - gradient: focusing
 - skew gradient: coupling

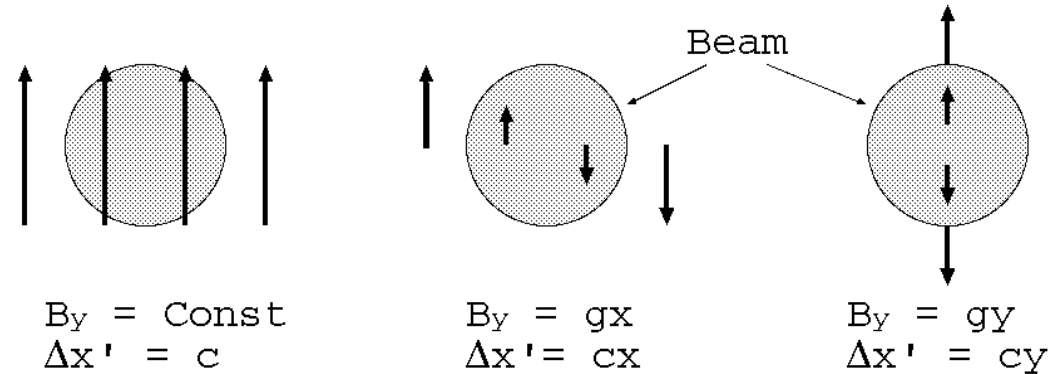

- Solenoid fields
 - detector
 - electron cooler

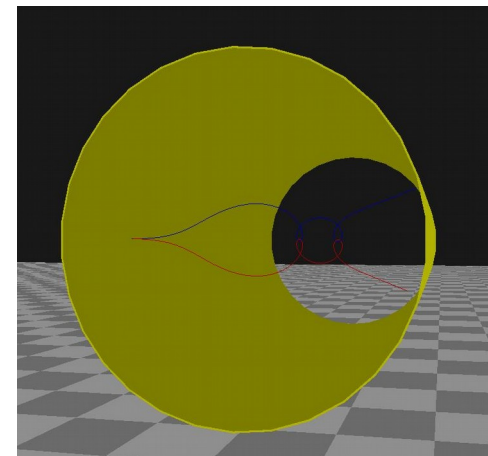



Sources of Imperfections

- Anything that is not in the design lattice
- Fringe fields and cross talk between magnets
- Saturation of magnets
- Power supply calibration and read back errors
- Wrong shims
- Earth magnetic field in low-energy beam lines
- Nickel layers in the wrong place
- Solenoids in detectors or coolers
- Weak focusing from wigglers
- Tilt and roll angles of magnets
- Misaligned magnets (or beams)

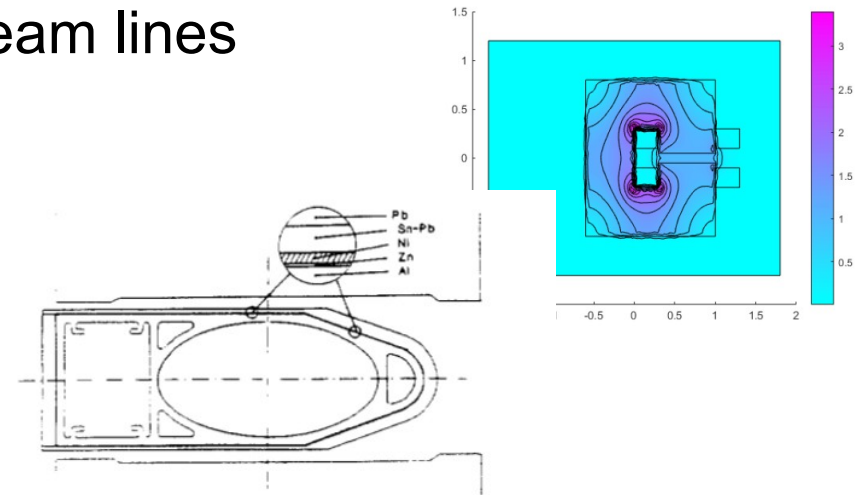
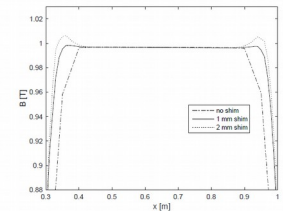
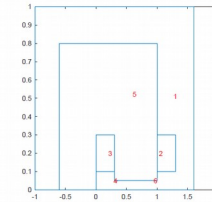
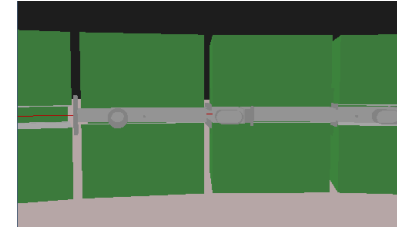

Figure 1: *The LEP dipole chamber and its nickel layer*

J. Billan et al., PAC 1993



Alignment

- How do you do it?
 - Magnets on tables
 - Fiducialization to pods
 - Triangulation
- How well can you do it?
 - 0.2-0.3 mm OK
 - <0.1 mm increasingly more difficult
 - more difficult in large installations
- Sub-micron for linear colliders → beam-based

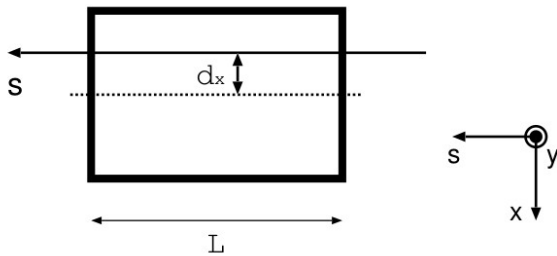

Photo: R. Ruber, CTF3-TBTS



Misaligned Magnets

- Misalignment of linear elements



$$\begin{aligned} \begin{pmatrix} x_f \\ x'_f \end{pmatrix} &= \begin{pmatrix} -d_x \\ 0 \end{pmatrix} + \tilde{R} \left[\begin{pmatrix} d_x \\ 0 \end{pmatrix} + \begin{pmatrix} x_i \\ x'_i \end{pmatrix} \right] \\ &= \tilde{R} \begin{pmatrix} x_i \\ x'_i \end{pmatrix} + [\tilde{R} - 1] \begin{pmatrix} d_x \\ 0 \end{pmatrix} = \vec{q} + \tilde{R} \begin{pmatrix} x_i \\ x'_i \end{pmatrix} \end{aligned}$$

- and for a thin quadrupole...

$$\vec{q} = [\tilde{R} - 1] \begin{pmatrix} d_x \\ 0 \end{pmatrix} = \begin{pmatrix} 0 & 0 \\ -\frac{1}{f} & 0 \end{pmatrix} \begin{pmatrix} d_x \\ 0 \end{pmatrix} = \begin{pmatrix} 0 \\ -\frac{d_x}{f} \end{pmatrix}$$

- An additional dipolar kick appears → **feed-down**



Misaligned quadrupoles focus just as good as centered ones

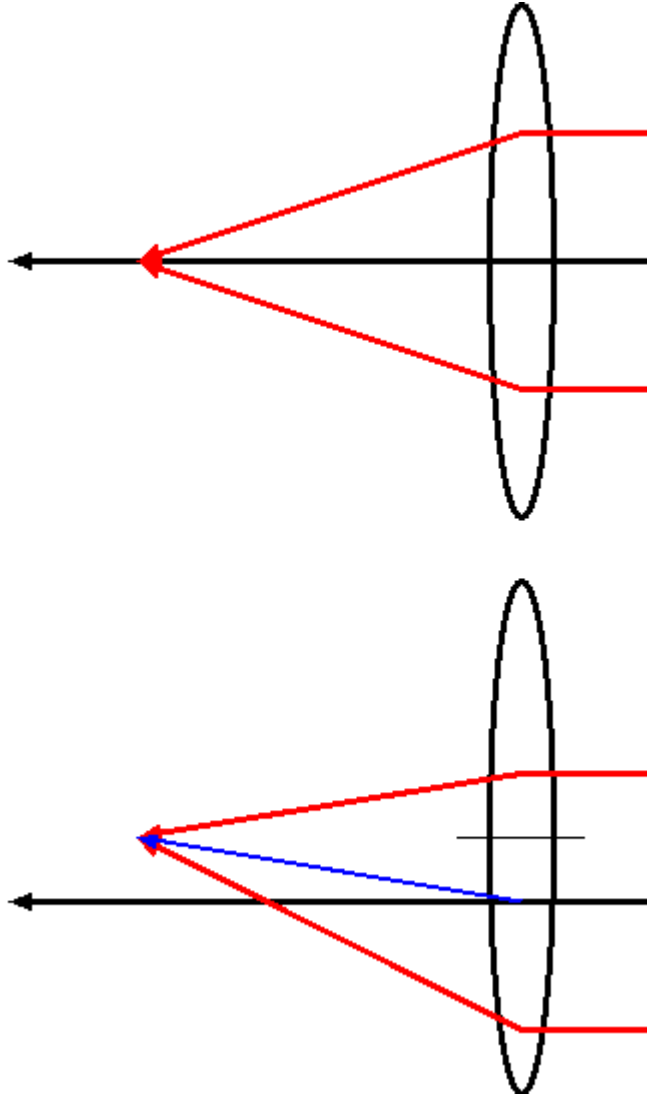

- Same focal length despite misalignment
- Lower ray is further away from the quad center and bent more
- Upper ray is closer to axis and is bent less
- But they kick the centroid of the beam



Tilted elements

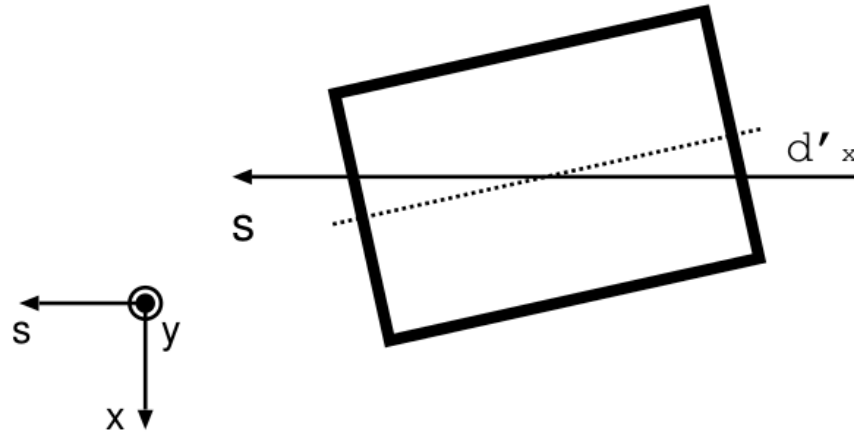

- come in, step right and point left, go through, step right again and point right

$$\begin{aligned} \begin{pmatrix} x_f \\ x'_f \end{pmatrix} &= \begin{pmatrix} -d'_x L/2 \\ -d'_x \end{pmatrix} + \hat{R} \left[\begin{pmatrix} -d'_x L/2 \\ d'_x \end{pmatrix} + \begin{pmatrix} x_i \\ x'_i \end{pmatrix} \right] \\ &= \hat{R} \begin{pmatrix} x_i \\ x'_i \end{pmatrix} + \left[\hat{R} + \begin{pmatrix} 1 & 0 \\ 0 & -1 \end{pmatrix} \right] \begin{pmatrix} -d'_x L/2 \\ d'_x \end{pmatrix} = \vec{q} + \tilde{R} \begin{pmatrix} x_i \\ x'_i \end{pmatrix} \end{aligned}$$

- Again, normal transport and a constant vector



DIY: calculate 'tilted' $\vec{q} = \left[\hat{R} + \begin{pmatrix} 1 & 0 \\ 0 & -1 \end{pmatrix} \right] \begin{pmatrix} -d'_x L/2 \\ d'_x \end{pmatrix}$

I use octave-like pseudo-code with notation as in the Octave/Matlab version of the tutorial

<https://arxiv.org/abs/1907.10987>

```
% calculate_vec_q_for_tilt.m
F=2.5; % focal length of the quadrupoles
fodo=[ 1, 1, 1.0, 0; % Drift 1m
       2, 1, 0.0, -F; % QD
       1, 1, 2.0, 0; % Drift 2m
       2, 1, 0.0, F; % QF
       1, 1, 1.0, 0]; % Drift 1m
beamline=[fodo;fodo];
[Racc,spos,nmat,nlines]=calcmat(beamline);
% tilt both quads in first cell, element 2 to 4 (note all repeat codes are 1)
L=spos(4)-spos(2) % end of fourth element minus second
dprime=1e-3;
% Racc start with unit matrix 'before' the beam line
Rhat=Racc(:,:,5)*inv(Racc(:,:,4))
Rhat(1,1)=Rhat(1,1)+1;
Rhat(2,2)=Rhat(2,2)-1;
qvec=Rhat*[-dprime/L, dprime]'
```

a little simplified
NO repeat codes
to avoid book keeping



Longitudinally Shifted Elements

- Add a short positive element on one side and the negative on the other
- Dipole
 - kick on either side
- Quadrupoles
 - thin quadrupoles

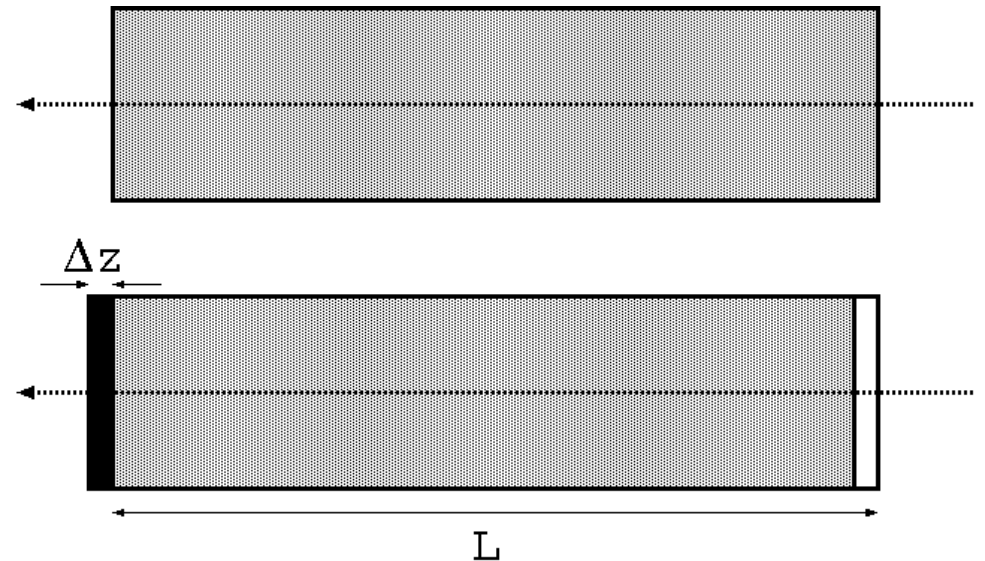

How would you implement this in your code?

Incorrectly powered Quadrupoles

- Focal length changes
 - beam matrix differs from the expected
 - beta functions change
 - in rings, the tune changes

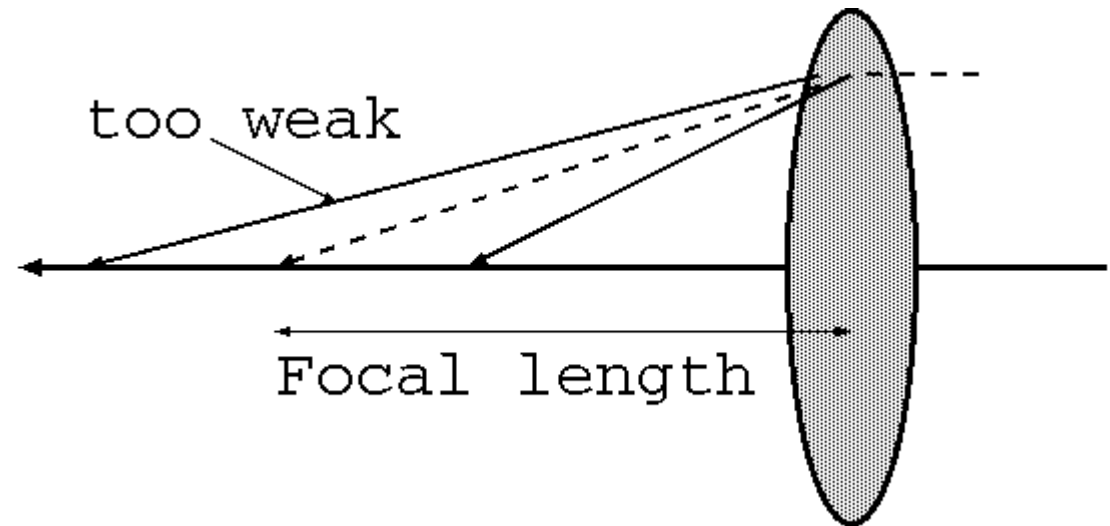



Undulators and Wigglers

- $B_y \sim \cos(2\pi s/\lambda_u) \rightarrow$ horizontal oscillations
- $\partial B_y/\partial s = \partial B_s/\partial y \rightarrow$ vertically changing B_s
- Focus vertically (only)
- Many Rbends
- weak effect $(l/\rho)^2$, but
- changing gap may
 - affect orbit
 - affect tune

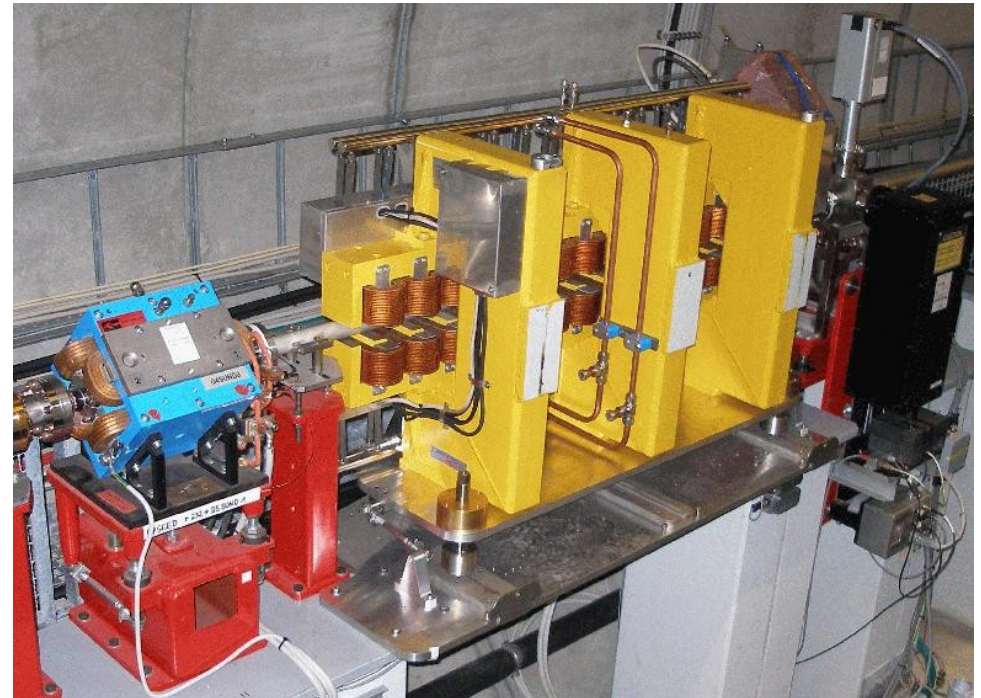

“Hilda”



Dispersion

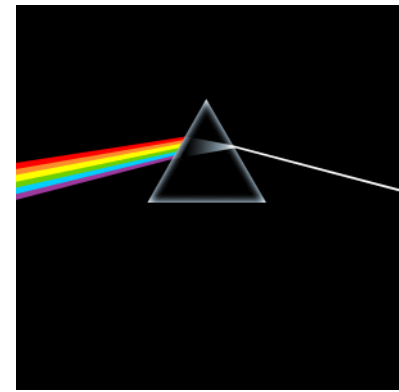

- Effect of magnetic fields on the beam ($\sim B/p$) with $p=p_0(1+\delta)$ is reduced by $1+\delta$
- Every dipole behaves as a spectrometer
 - separates the particles according to their momentum
 - even dipole correctors contribute
- In planar systems the vertical dispersion is by design zero
 - but rolled dipoles (and quadrupoles) make it non-zero.

Check out hands-on exercises 33 to 38 about how this is done in software!



Chromaticity

- Also quadrupolar fields are reduced by $1+\delta$
 - longitudinal location of the focal plane depends on momentum and enlarges the beam sizes at the IP
 - chromaticity $Q'=dQ/d\delta$
 - tune spread

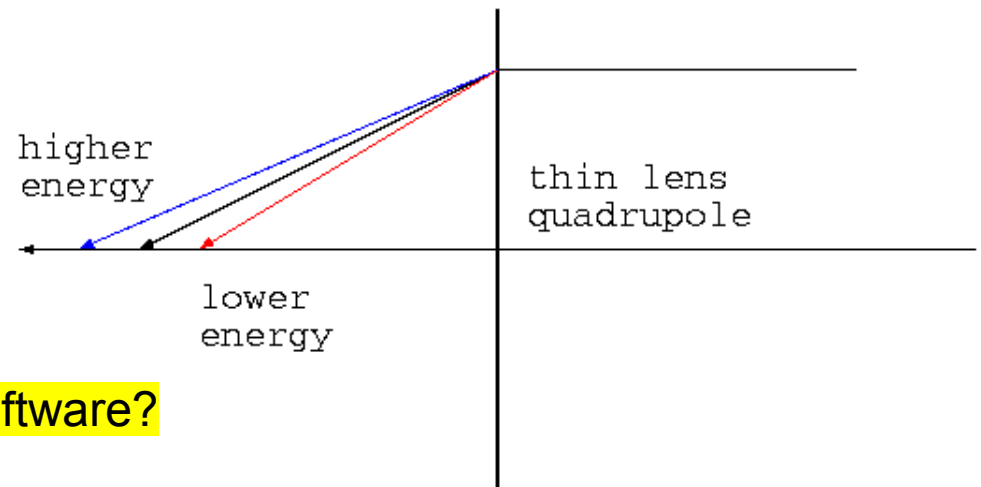

How would you implement this in your software?



Measuring Dispersion and Chromaticity

- Change the beam energy, in rings by changing the RF frequency
 - and look at orbit from BPMs (dispersion)
 - and measure the tune (chromaticity)
- In transfer line or linac change the energy of the injected beam
- Optionally, may scale all magnets with the same factor
 - all beam observables $\sim B/p$



Rolled elements

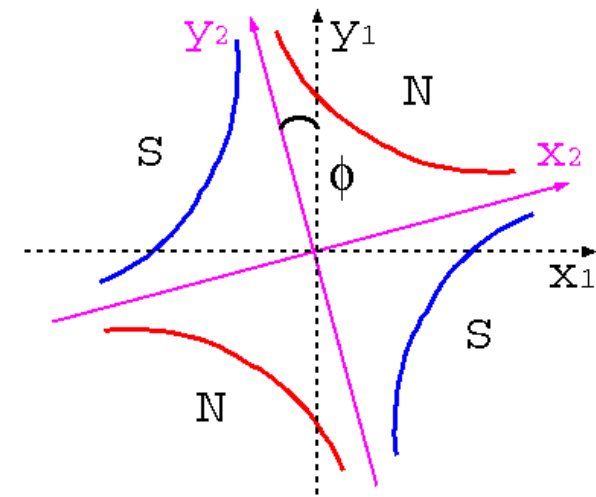

- Coordinate rotation

$$\begin{pmatrix} x_2 \\ x'_2 \\ y_2 \\ y'_2 \end{pmatrix} = \begin{pmatrix} \cos \phi & 0 & \sin \phi & 0 \\ 0 & \cos \phi & 0 & \sin \phi \\ -\sin \phi & 0 & \cos \phi & 0 \\ 0 & -\sin \phi & 0 & \cos \phi \end{pmatrix} \begin{pmatrix} x_1 \\ x'_1 \\ y_1 \\ y'_1 \end{pmatrix}$$

- sandwich roll-left before the element and then roll-right after the element
- example quad to skew-quad (example, thin quad)

$$Q_s = R(-\pi/4) \begin{pmatrix} Q_f & 0_2 \\ 0_2 & Q_d \end{pmatrix} R(\pi/4) = \begin{pmatrix} 1 & 0 & 0 & 0 \\ 0 & 1 & 1/f & 0 \\ 0 & 0 & 1 & 0 \\ 1/f & 0 & 0 & 1 \end{pmatrix}$$

- mixes the transverse planes → coupling



Reminder: Multipoles

- Magnet builder's view (b_m : upright, a_m : skew)

$$B_y + iB_x = B_0 \sum_{m=1}^{\infty} (b_m + ia_m) \left(\frac{x + iy}{R_0} \right)^{m-1}$$

- How the beam “sees” the fields

modulo a sign due to the particle type

$$\Delta x' - i\Delta y' = \frac{(B_y + iB_x)L}{B\rho} = \sum_{n=0}^{\infty} \frac{k_n L}{n!} (x + iy)^n$$

- Multipole coefficients

– real part: upright

– imaginary part: skew

$$\frac{k_n L}{n!} = \frac{(B_0/R_0^n)L}{B\rho} (b_{n+1} + ia_{n+1})$$



Feed-down from displaced multipoles

- Kick from thin multipole $\Delta x' - i\Delta y' = \frac{k_n L}{n!} (x + iy)^n$

- and from a displaced multipole

$$\Delta x' - i\Delta y' = \frac{k_n L}{n!} (x + d_x + iy)^n$$

$$= \frac{k_n L}{n!} (x + iy)^n + \frac{k_n L}{n!} \sum_{k=0}^{n-1} \binom{n}{k} d_x^{n-k} (x + iy)^k$$

– binomial expansion

- Displaced multipole still works as intended, but also generates all lower multipoles

Feed-down from sextupoles

- Horizontally misaligned

$$\Delta x' - i\Delta y' = \frac{k_2 L}{2} [(x + iy)^2 + 2d_x(x + iy) + d_x^2]$$

- additional quadrupolar and dipolar kicks

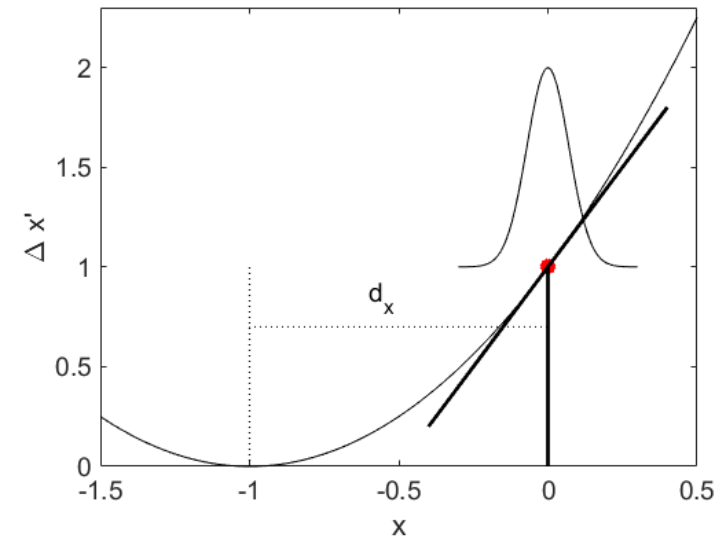

- Vertically misaligned

$$\Delta x' - i\Delta y' = (x + iy + id_y)^2 = \frac{k_2 L}{2} [(x + iy)^2 + 2id_y(x + iy) - d_y^2]$$

- additional skew-quadrupolar and dipole kicks
- vertical displacement in sextupoles causes coupling



Detrimental effects

- Dipole fields cause beam to be in wrong place
 - losses, bad if you have a multi-MJ beam
 - Background in the experiments
- Gradients change the beam size, this spoils
 - Luminosity, if you work on a collider
 - Coherence, if you work on a light source
- Breaks the symmetry of the optics of a ring
 - more resonances
 - reduces dynamic aperture
- Need observables to figure out what's wrong



Beam Position Monitors and their Imperfections

- Transverse offset
- (Longitudinal position)
- Electrical offset
- Scale error

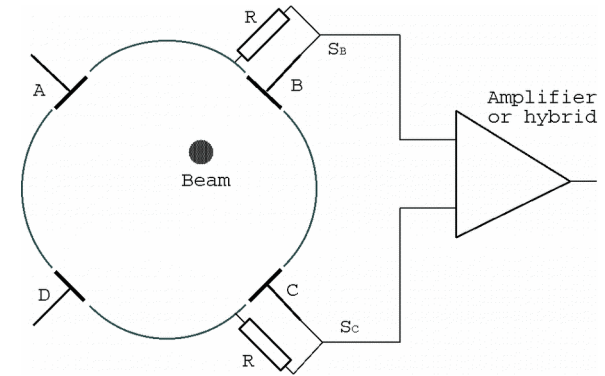

$$x = k_x \frac{(S_A + S_D) - (S_B + S_C)}{S_A + S_B + S_C + S_D}$$

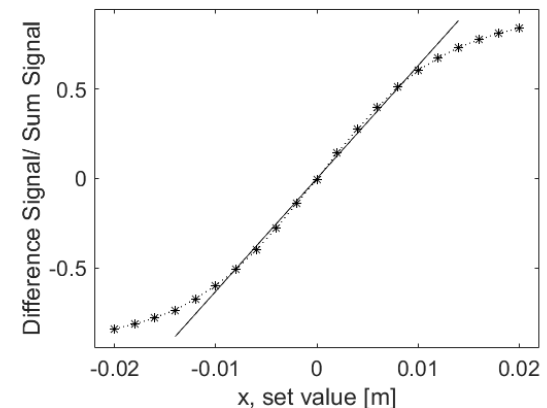
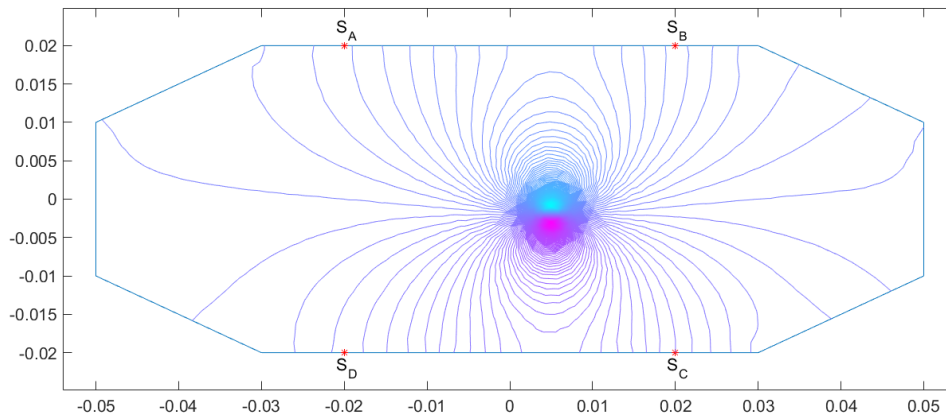



Find offsets with K-modulation

- BPM+Quadrupole are often mounted on the same support

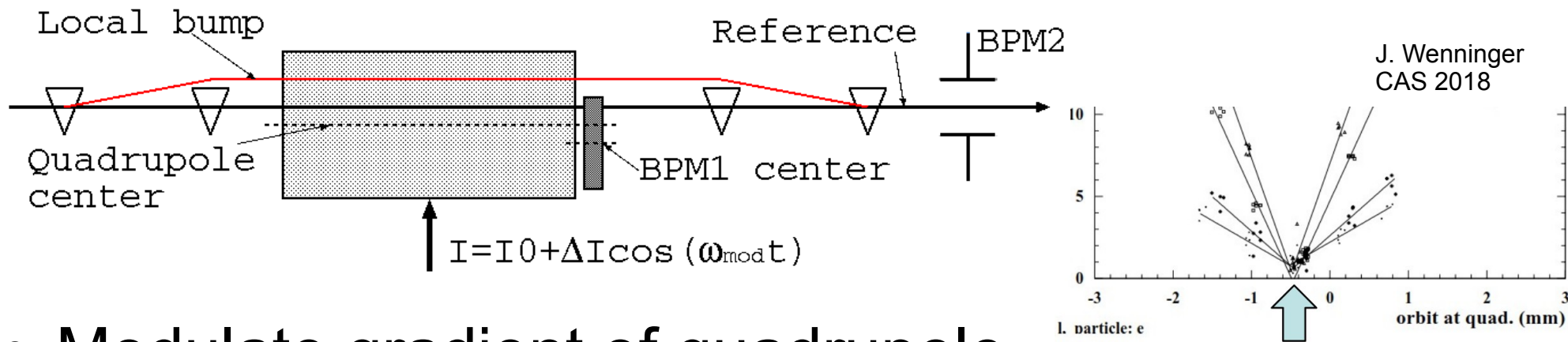

- Modulate gradient of quadrupole
 - Kick from quadrupole $\Theta = dx/f(\omega)$ is also modulated
 - Observe on BPM2 and minimize signal by moving beam with a bump \rightarrow quadrupole center
 - Reading of BPM1 gives BPM1 offset rel. to Quad



Screens et al. and their Bugs

- Transverse position
- Scale errors from the optical system
 - place fiducial marks on the screen
- Looking at an angle
- Depth of focus limitations, especially at large magnification levels
- Burnt-out spots on fluorescent screens
- Non-linear response of screen and saturation

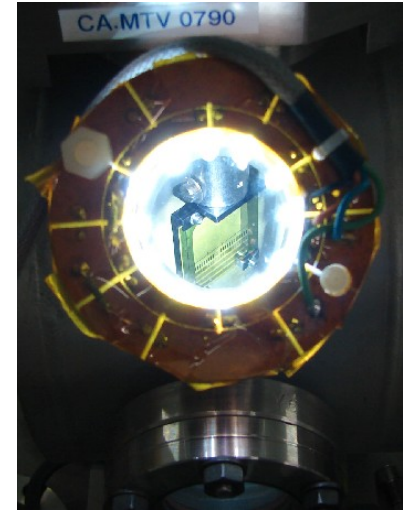
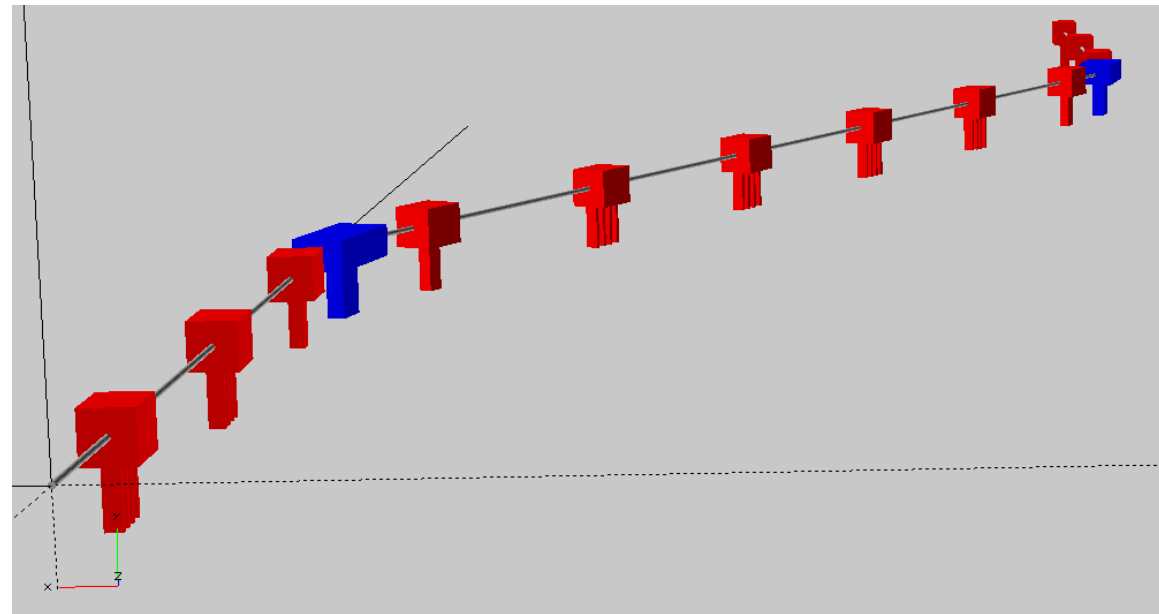

Photo taken by M. Jacewicz

Imperfections and their Correction in Beam Lines or Linacs

- Dipole errors
- Gradient errors
- Skew-gradient errors
- Filamentation





Transfer matrices in linacs

- Just a reminder...
- The beam energy at the location for the kick and the observation point may be different.
- Adiabatic damping
 - transverse momentum p_x is constant
 - longitudinal momentum p_s increases
 - $x' = p_x/p_s$ scales with $p_s = \beta\gamma mc$
- R_{12} then scales with $(\beta\gamma)_{\text{kick}}/(\beta\gamma)_{\text{look}}$



Beam lines: Dipole errors

- Each misaligned element with label k may add a misalignment dipole-kick \vec{q}_k

$$\begin{aligned}\vec{x}_n &= R_n \cdots (\vec{q}_{k+1} + R_{k+1})(\vec{q}_k + R_k) \cdots (\vec{q}_1 + R_1)\vec{x}_0 \\ &= R_n \cdots R_1 \vec{x}_0 + \sum_{j=1}^{n-1} (R_n \cdots R_{j+1}) \vec{q}_j\end{aligned}$$

- Simple interpretation
 - at the look-point (BPM) n all perturbing kicks are added with the transfer matrix from kick to end

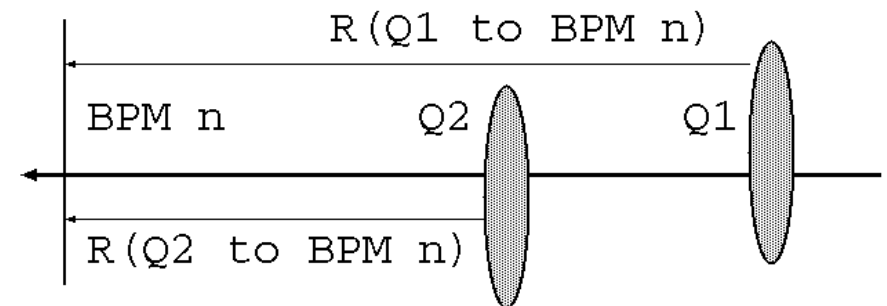



DIY: in software

- We need all transfer matrices from the location with errors (k) to the BPM (n)

```
% all_transfer_matrices.m
:
beamline=.. % define the beamline
[Racc,spos,nmat,nlines]=calcmat(beamline);

table_of_errpos=[..,k,..] % position of errors
n= % position in lattice file of BPM
]for k=1:length(table_of_errpos)
    errpos=table_of_errpos(k)-1; % from just upstream of error
    RR(k)=Racc(:, :, n)*inv(Racc(:, :, errpos));
end
```

more details, explanations, and example code
at <https://www.crcpress.com/9781138589940>



Correct with orbit correctors

- small dipole magnet, here for both planes (steerer for CTF3-TBTS)
- affects the beam like any other error

$$\begin{pmatrix} x_1 \\ x'_1 \end{pmatrix} = \begin{pmatrix} 0 \\ \theta \end{pmatrix} + \begin{pmatrix} x_0 \\ x'_0 \end{pmatrix}$$

$$\vec{x}_1 = \vec{q} + \tilde{R}\vec{x}_0$$

- treat just as additional misalignment

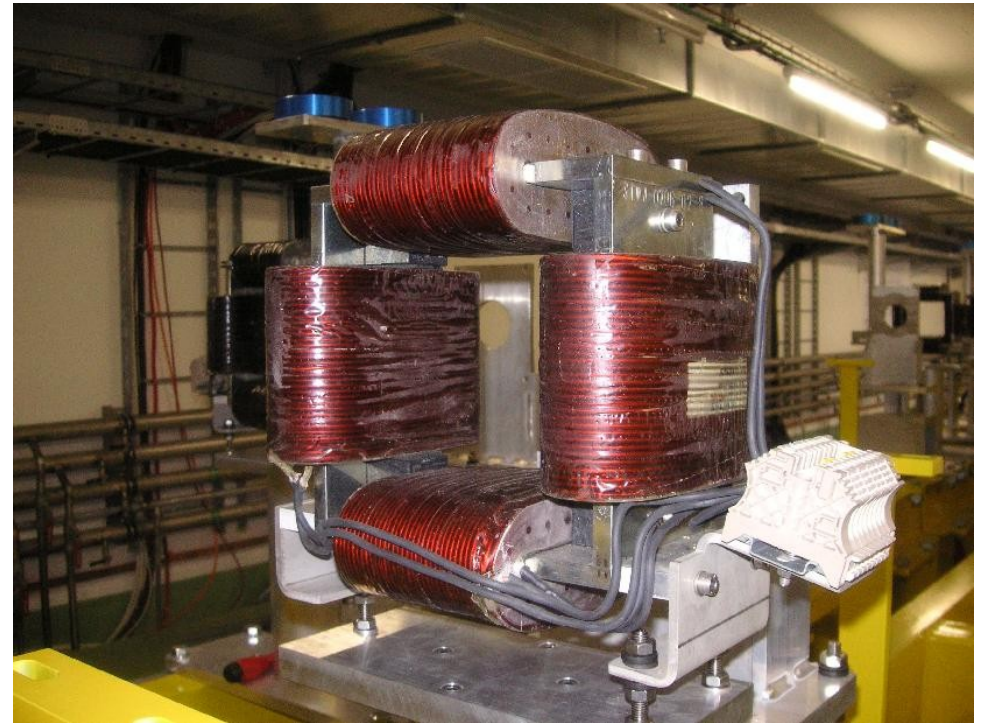



Local trajectory Bumps

- Occasionally a particular displacement or angle of the orbit at a given point might be required
- Displace orbit at IP to bring beams into collision

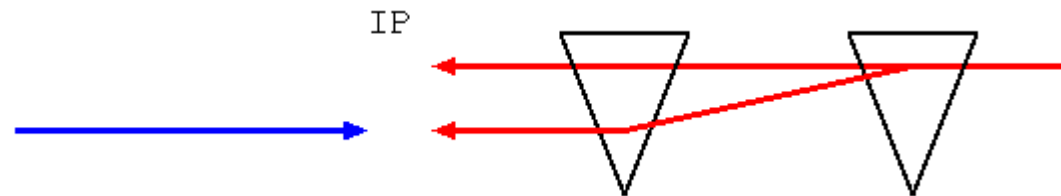

- or a slight excursion (3-bump)

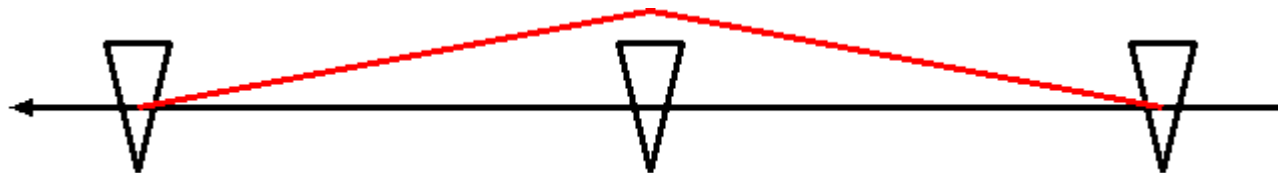

- Differential changes ('by' not 'to')



Trajectory knob

- Change position and angle at reference point

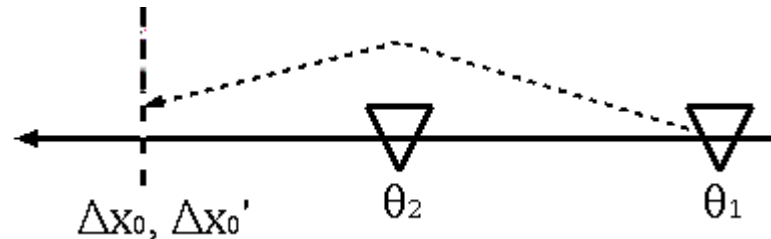

- Remember that kicks add up with TM from source to observation or reference point

$$\begin{pmatrix} \Delta x_0 \\ \Delta x'_0 \end{pmatrix} = \begin{pmatrix} R_{12}^{01} & R_{12}^{02} \\ R_{22}^{01} & R_{22}^{02} \end{pmatrix} \begin{pmatrix} \theta_1 \\ \theta_2 \end{pmatrix}$$

- and the **columns of the inverse matrix** are the knobs

$$\begin{pmatrix} \theta_1 \\ \theta_2 \end{pmatrix} = \begin{pmatrix} R_{12}^{01} & R_{12}^{02} \\ R_{22}^{01} & R_{22}^{02} \end{pmatrix}^{-1} \begin{pmatrix} \Delta x_0 \\ \Delta x'_0 \end{pmatrix}$$



A trivial example

- Two steering magnets with drift between them

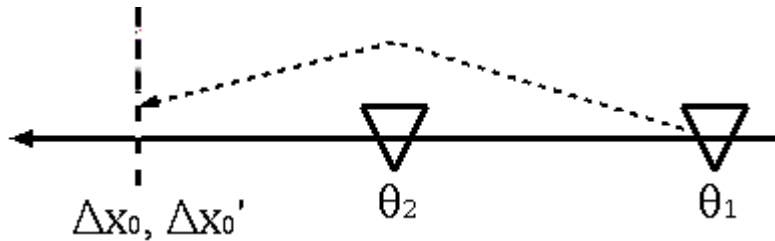

$$R^{02} = \begin{pmatrix} 1 & L \\ 0 & 1 \end{pmatrix} \quad R^{01} = \begin{pmatrix} 1 & 2L \\ 0 & 1 \end{pmatrix}$$

- Response matrix

$$\begin{pmatrix} \Delta x_0 \\ \Delta x'_0 \end{pmatrix} = \begin{pmatrix} R_{12}^{01} & R_{12}^{02} \\ R_{22}^{01} & R_{22}^{02} \end{pmatrix} \begin{pmatrix} \theta_1 \\ \theta_2 \end{pmatrix} = \begin{pmatrix} 2L & L \\ 1 & 1 \end{pmatrix} \begin{pmatrix} \theta_1 \\ \theta_2 \end{pmatrix}$$

- Knobs

$$\begin{pmatrix} \theta_1 \\ \theta_2 \end{pmatrix} = \frac{1}{L} \begin{pmatrix} 1 & -L \\ -1 & 2L \end{pmatrix} \begin{pmatrix} \Delta x_0 \\ \Delta x'_0 \end{pmatrix} \longrightarrow \begin{pmatrix} \theta_1 \\ \theta_2 \end{pmatrix} = \frac{1}{L} \begin{pmatrix} 1 \\ -1 \end{pmatrix} \Delta x_0$$

Almost common sense!



Remark about Orthogonality

- Knobs are orthogonal
- Optimize one parameter without screwing up the other(s).
 - Faster convergence
 - Enables heuristic optimization
 - Deterministic
- Use physics rather than hardware parameters

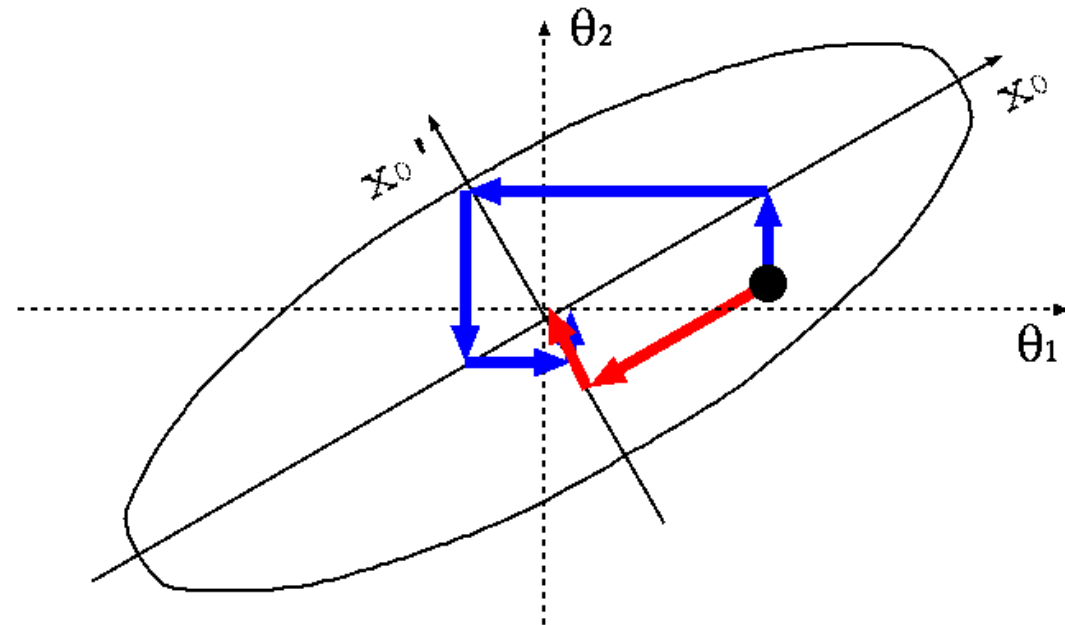



Optimality

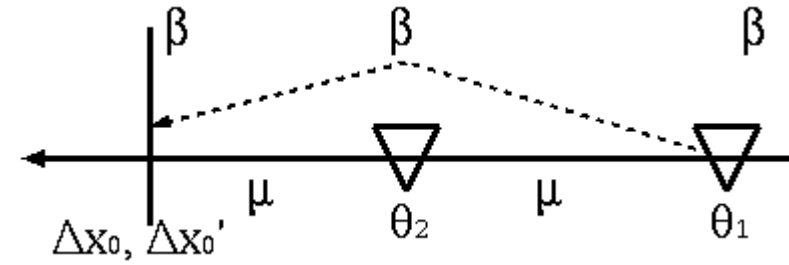

- How “good” are the knobs?
- Position knob is ill-defined for $L \rightarrow 0$. $\begin{pmatrix} \theta_1 \\ \theta_2 \end{pmatrix} = \frac{1}{L} \begin{pmatrix} 1 \\ -1 \end{pmatrix} \Delta x_0$
- Matrix inversion can fail \rightarrow condition number $\xi = \frac{\lambda_{max}}{\lambda_{min}}$
 - $\xi=1$: All parameters controlled equally well
- Consider beamline with betas equal and $\alpha=0$ at steerers and observation point

$$\begin{pmatrix} \Delta x_0 \\ \Delta x'_0 \end{pmatrix} = \begin{pmatrix} R_{12}^{01} & R_{12}^{02} \\ R_{22}^{01} & R_{22}^{02} \end{pmatrix} \begin{pmatrix} \theta_1 \\ \theta_2 \end{pmatrix}$$

$$\begin{pmatrix} \Delta x / \sqrt{\beta} \\ \sqrt{\beta} \Delta x' \end{pmatrix} = \begin{pmatrix} \sin 2\mu & \sin \mu \\ \cos 2\mu & \cos \mu \end{pmatrix} \begin{pmatrix} \sqrt{\beta} \theta_1 \\ \sqrt{\beta} \theta_2 \end{pmatrix}$$

- Generally applicable

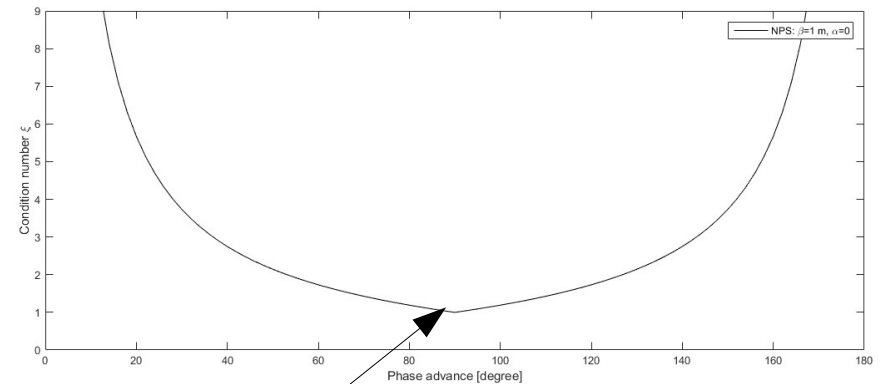

90°, common sense!



4-Bump

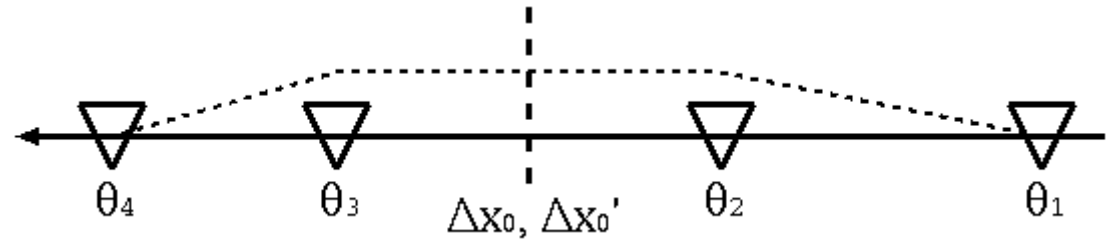

- Use four steerers to adjust angle and position at a center point and then flatten orbit downstream of the last steerer.

$$\begin{pmatrix} x_0 \\ x'_0 \\ x_f = 0 \\ x'_f = 0 \end{pmatrix} = \begin{pmatrix} R_{12}^{01} & R_{12}^{02} & 0 & 0 \\ R_{22}^{01} & R_{22}^{02} & 0 & 0 \\ R_{12}^{f1} & R_{12}^{f2} & R_{12}^{f3} & R_{12}^{f4} \\ R_{22}^{f1} & R_{22}^{f2} & R_{22}^{f3} & R_{22}^{f4} \end{pmatrix} \begin{pmatrix} \theta_1 \\ \theta_2 \\ \theta_3 \\ \theta_4 \end{pmatrix}$$

- Invert matrix and express thetas as a function of the constraints x_0 and x'_0
- Gives the required steering excitations θ_j as a function of x_0 and x'_0 → Multiknob



DIY: software bumps

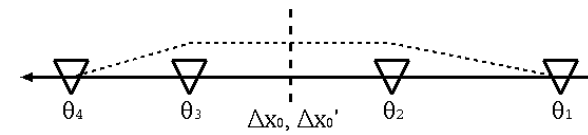

$$\begin{pmatrix} x_0 \\ x'_0 \\ x_f = 0 \\ x'_f = 0 \end{pmatrix} = \begin{pmatrix} R_{12}^{01} & R_{12}^{02} & 0 & 0 \\ R_{22}^{01} & R_{22}^{02} & 0 & 0 \\ R_{12}^{f1} & R_{12}^{f2} & R_{12}^{f3} & R_{12}^{f4} \\ R_{22}^{f1} & R_{22}^{f2} & R_{22}^{f3} & R_{22}^{f4} \end{pmatrix} \begin{pmatrix} \theta_1 \\ \theta_2 \\ \theta_3 \\ \theta_4 \end{pmatrix}$$

```
% software_bumps.m
:
beamline=.. % define the beamline
[Racc,spos,nmat,nlines]=calcmat(beamline);

n=.. % x0, position where I care
cor=[p1,p2,p3,p4]; % table of four corrector positions

R01=Racc(:,:,n)*inv(Racc(:,:,p1-1));
R02=Racc(:,:,n)*inv(Racc(:,:,p2-1));
R41=Racc(:,:,p4)*inv(Racc(:,:,p1-1)); % '4'=final
R42=Racc(:,:,p4)*inv(Racc(:,:,p2-1));
R43=Racc(:,:,p4)*inv(Racc(:,:,p3-1));
R44=Racc(:,:,p4)*inv(Racc(:,:,p4-1)); % is unit matrix
A=[R01(1,2),R02(1,2),0,0;
   R01(2,2),R02(2,2),0,0;
   R41(1,2),R42(1,2),R43(1,2),R44(1,2);
   R41(2,2),R42(2,2),R43(2,2),R44(2,2)];

knobs=inv(A) % invert the 'response'
knob_x0=knobs(:,1) % first column
knob_x0p=knobs(:,2) % second column
```

- Setup beam line
- Get transfer matrices
- Assemble matrix
- Invert it
- Knobs are columns of the inverse matrix
 - knob(1,1) is the proportionality constant to change θ_1 when changing only x_0

Orbit Correction in Beamline #1

- Observe the orbit on beam-position monitors
- and correct with steering dipoles
- How much do we have to change the steering magnets in order to compensate the observed orbit either to zero or some other 'golden orbit'.
- In beam line the effect of a corrector on the downstream orbit is given by transfer matrix element R_{12}
- One-to-one steering

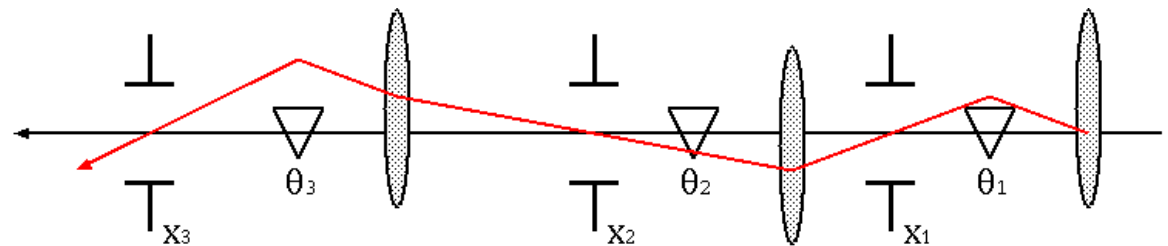



Orbit correction in a Beamline #2

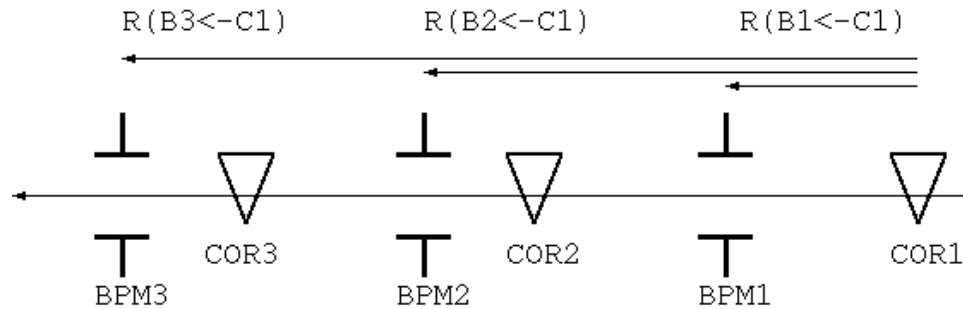

$$\begin{pmatrix} -x_1 \\ -x_2 \\ -x_3 \end{pmatrix} = \begin{pmatrix} R_{12}^{11} & 0 & 0 \\ R_{12}^{21} & R_{12}^{21} & 0 \\ R_{12}^{31} & R_{12}^{32} & R_{12}^{33} \end{pmatrix} \begin{pmatrix} \theta_1 \\ \theta_2 \\ \theta_3 \end{pmatrix}$$

- Observed beam positions x_1 , x_2 , and x_3
- Only downstream BPM can be affected
- Linear algebra problem to **invert matrix** and find required corrector excitations θ_j to produce negative of observed x_i
- Include BPM errors by left-multiplying the equation with

$$\bar{\Lambda} = \text{diag} \left(\frac{1}{\sigma_1}, \dots, \frac{1}{\sigma_n} \right)$$

This weights each BPM measurement by its inverse error. Good BPMs are trusted more!



How to get the response matrix?

- With the computer (MADX or any other code)
 - tables of transfer matrix elements
 - but it is based on a model and somewhat idealized
 - no BPM or COR scale errors known
- Experimentally by measuring difference orbits
 - record reference orbit \vec{x}_0
 - change steering magnet $\Delta\theta_j$
 - record changed orbit \vec{x}_j
 - Build response matrix one column at a time

$$A = \left(\frac{\vec{x}_1 - \vec{x}_0}{\Delta\theta_1}, \frac{\vec{x}_2 - \vec{x}_0}{\Delta\theta_2}, \dots \right)$$



Solving $-x=A\theta$

- A is an $n \times m$ matrix, n BPM and m correctors
- $n=m$ and matrix A is non-degenerate:

$$\vec{\theta} = -A^{-1}\vec{x}$$

- $m < n$: too few correctors, least squares $\chi^2 = |-\vec{x} - A\vec{\theta}|^2$

$$\vec{\theta} = -(A^t A)^{-1} A^t \vec{x}$$

- MICADO: pick the most effective, fix orbit, the next effective, fix residual orbit, the next...
 - good for large rings with many BPM and COR
- $m > n$ or degenerate: singular-value dec. (SVD)



Digression on SVD

- Singular Value Decomposition $A = O\Lambda U^t$
 - may need to zero-pad
 - U is orthogonal, a coordinate rotation
 - Λ is diagonal, it stretches the coordinates by λ_i
 - O is orthogonal and rotates, but differently
- If A is symmetric \rightarrow eigenvalue decomposition
- Inversion is trivial $”A^{-1}” = U\Lambda^{-1}O^t$
 - invert only in sub-space where you can if $\lambda \neq 0$
 - and set projection onto degenerate subspace to zero
“ $1/0 = 0$ ” (see *Numerical Recipes* for a discussion)



DIY: calculate “SVD-inverse”

- Consider 2x2 matrix
 - and invert it as $z \rightarrow 0$

$$A = \begin{pmatrix} 1 & 2 \\ 2+z & 4 \end{pmatrix}$$

```
% svd_example.m
clear all;
A=@(z)[1,2;2+z,4];
Atest=A(1);           % or A(0)
[O,L,V]=svd(Atest)   % A=O*L*V'
n=size(L,1);         % dimension of matrix
Linv=zeros(n,n);     % create matrix with all zeros
for k=1:size(L,1)    % invert where you can
    if abs(L(k,k)) > 1e-8 Linv(k,k)=1/L(k,k); end
end
Ainv=V*Linv*O'       % calculate inverse
check=Atest*Ainv     % should be unit matrix, unless...
```



Comment on Matrix Inversion

- Many correction problems can be brought into a generic form, if you
 - pretend you know the excitation of all controllers (think correctors)
 - determine the response matrix (expt. or numerically)
$$C_{ij} = \partial \text{Observable}_i / \partial \text{Controller}_j$$
 - to predict the changes of the observables (think BPM)
- Then invert the response matrix to determine the controller values required to change the observable by some value.



Effect of gradient errors

Eight 90° FODO cells, first quad 10% too low

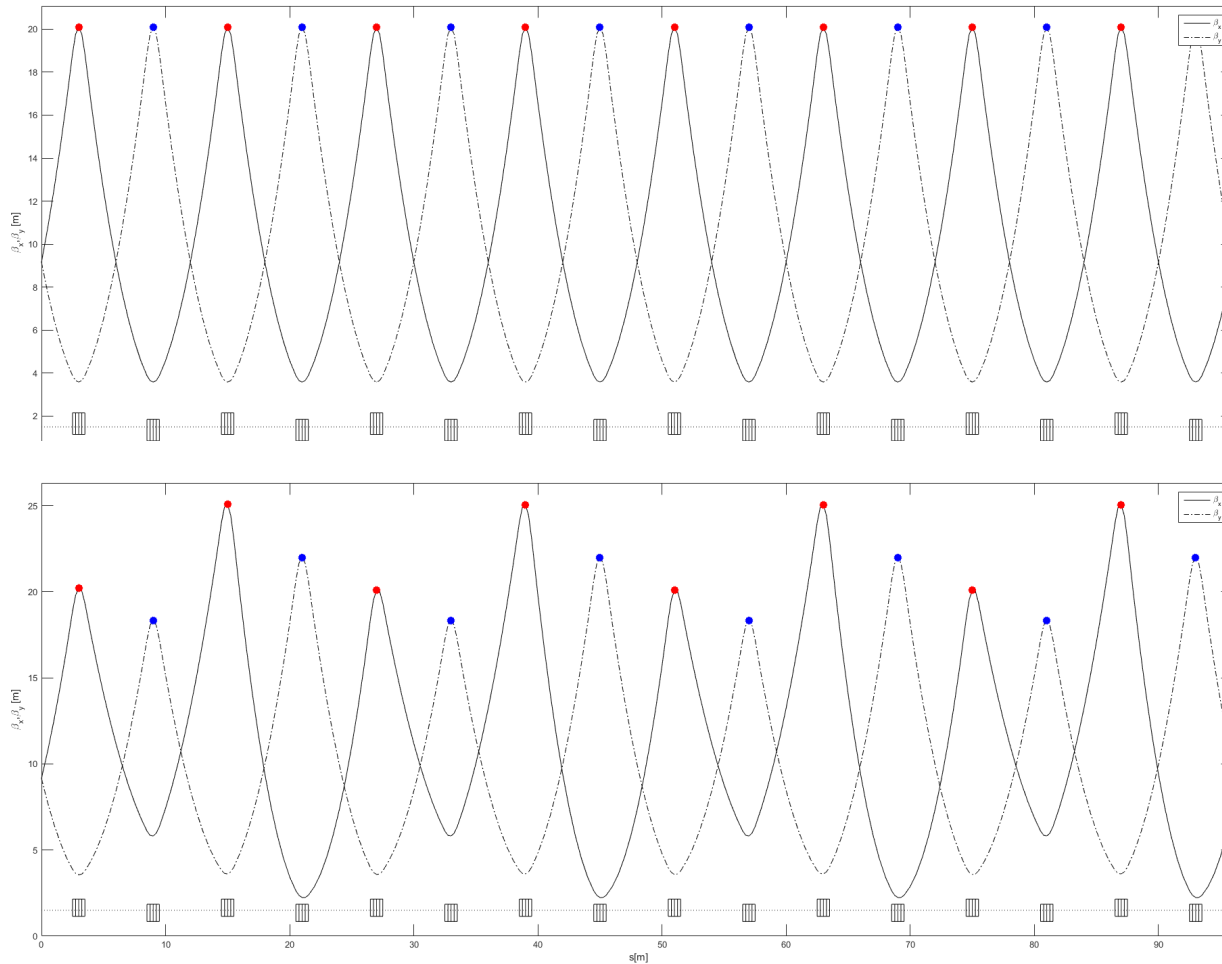

Unperturbed lattice

Nice and repetitive
beta functions

Repeats after
2 cells or 2 x 90°

Beta-function
“beats”

Injection into following
beam line or ring is
compromised



Beam lines: Gradient errors

- Gradient errors cause the beam matrix or beta functions β to differ from their design values $\hat{\beta}$
- Downstream beam size

$$\bar{\sigma}_x^2 = \varepsilon \bar{\beta} \left[B_{mag} + \sqrt{B_{mag}^2 - 1} \cos(2\mu - \varphi) \right]$$

- enlarged effective emittance, beta-beat oscillations with twice the betatron phase advance μ
- This is called mismatch and is quantified by

$$B_{mag} = \frac{1}{2} \left[\left(\frac{\hat{\beta}}{\beta} + \frac{\beta}{\hat{\beta}} \right) + \beta \hat{\beta} \left(\frac{\alpha}{\beta} - \frac{\hat{\alpha}}{\hat{\beta}} \right)^2 \right]$$

- For a single thin quad we have

$$B_{mag} = 1 + \frac{\hat{\beta}^2}{2f^2}$$



Filamentation #1

- What happens when we inject a mismatched beam into a ring with chromaticity Q' ?

$$\sigma_n^2 = \varepsilon \bar{\beta} \left[B_{mag} + \sqrt{B_{mag}^2 - 1} \cos(4\pi n(Q + Q'\delta) - \varphi) \right]$$

– with momentum distribution $\psi(\delta) = \frac{1}{\sqrt{2\pi}\sigma_\delta} e^{-\delta^2/2\sigma_\delta^2}$

- Averaging over δ gives

$$\sigma_n^2 = \varepsilon \bar{\beta} \left[B_{mag} + e^{-2(2\pi Q'\sigma_\delta)^2 n^2} \sqrt{B_{mag}^2 - 1} \cos(4\pi nQ - \varphi) \right]$$

- Oscillates with $2 \times Q$, 'damps' with $\exp(-n^2)$, and leaves an increased beam size (by B_{mag}).



Filamentation #2

You've seen it before...

Example for an unmatched and matched beam (taken from B. Schmidt):

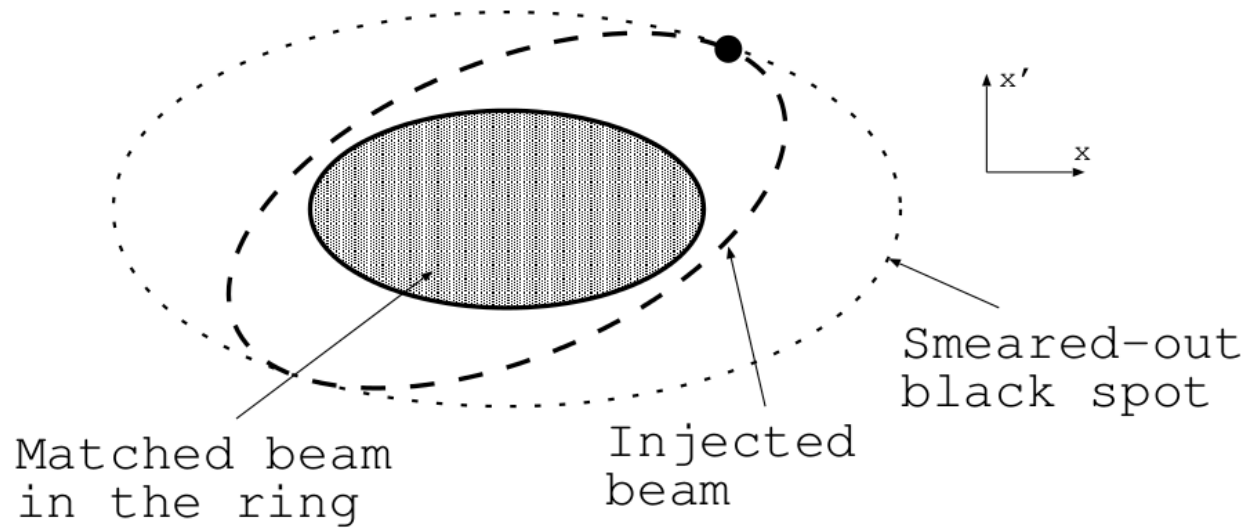
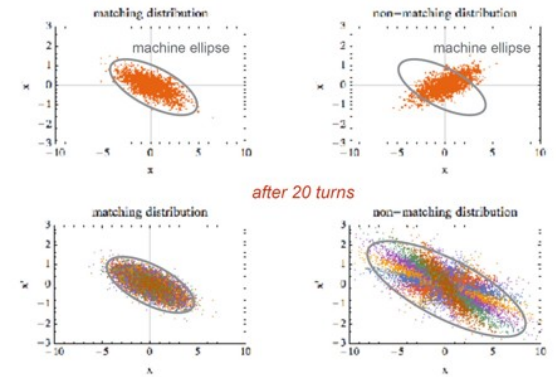

Injecting with transverse offset also leads to filamentation

Final distribution is not Gaussian

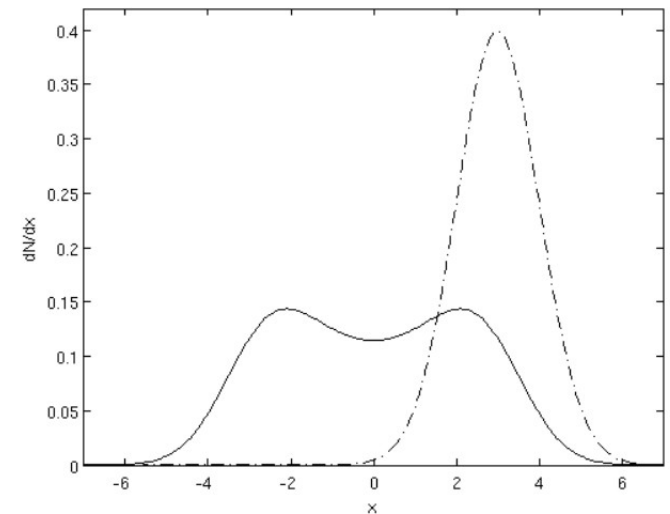
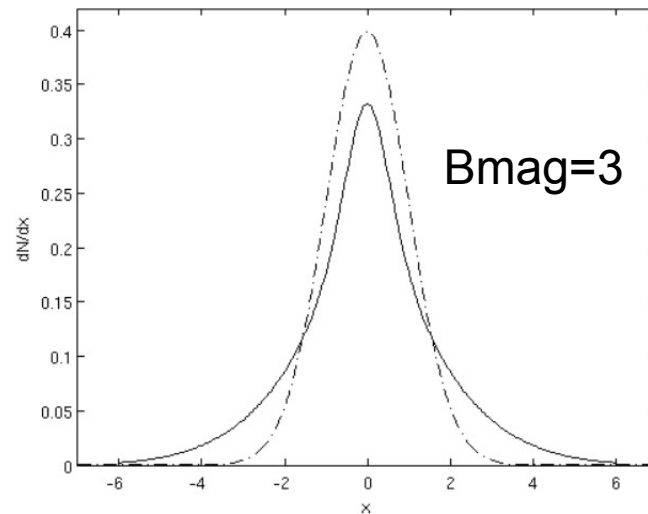



Measuring Beam Matrices

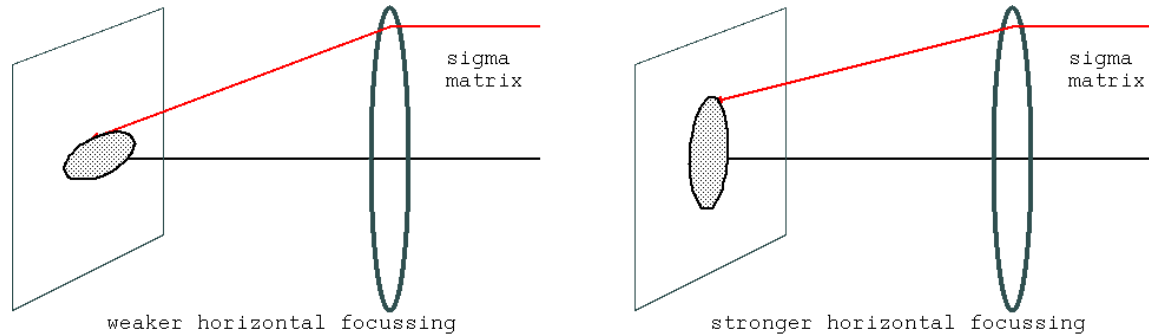

$$\bar{\sigma} = R(f) \sigma R(f)^t$$

Vary quadrupole and observe changes on a screen, usually one plane at a time

- Beam size on screen depends on quad setting

$$\bar{\sigma}_x^2 = \bar{\sigma}_{11} = R_{11}^2 \sigma_{11} + 2R_{11}R_{12}\sigma_{12} + R_{12}^2 \sigma_{22}$$

- where $R=R(f)$, use several measurement and solve for the three sigma matrix elements

$$\varepsilon_x^2 = \sigma_{11}\sigma_{22} - \sigma_{12}^2 \quad \beta_x = \sigma_{11}/\varepsilon_x \quad \alpha_x = -\sigma_{12}/\varepsilon_x$$



A worked example: Quad scan

UPPSALA
UNIVERSITET

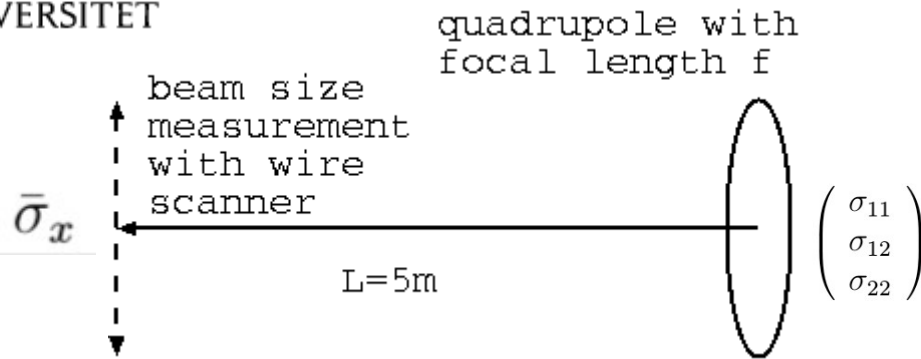

$1/f$ [1/m]	$\bar{\sigma}_x$ [mm]
0.1	6.0
0.2	3.5
0.3	2.5
0.4	4.3
0.5	7.0

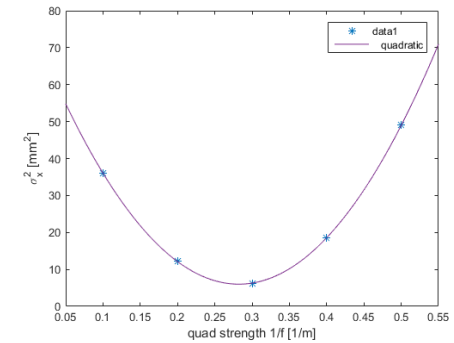

- Transfer matrix $R = \begin{pmatrix} 1 & l \\ 0 & 1 \end{pmatrix} \begin{pmatrix} 1 & 0 \\ -1/f & 1 \end{pmatrix} = \begin{pmatrix} 1 - l/f & l \\ -1/f & 1 \end{pmatrix}$
- Relate unknown beam matrix to measurements

$$\begin{aligned} \bar{\sigma}_x^2 &= R_{11}^2 \sigma_{11} + 2R_{11}R_{12}\sigma_{12} + R_{12}^2 \sigma_{22} \\ &= (1 - l/f)^2 \sigma_{11} + 2l(1 - l/f)\sigma_{12} + l^2 \sigma_{22} \\ &= \left(\frac{l}{f}\right)^2 \sigma_{11} - \left(\frac{l}{f}\right) (2\sigma_{11} + 2l\sigma_{12}) + (\sigma_{11} + 2l\sigma_{12} + l^2 \sigma_{22}) \end{aligned}$$

- Indeed a parabola in l/f



Quad scan #2

- Build matrix of the type $y=Ax$
 - and with error bars $\Sigma_k=2\sigma_k\Delta\sigma_k$

$$\begin{pmatrix} \bar{\sigma}_{x,1}^2 \\ \bar{\sigma}_{x,2}^2 \\ \bar{\sigma}_{x,3}^2 \\ \bar{\sigma}_{x,4}^2 \\ \bar{\sigma}_{x,5}^2 \end{pmatrix} = \begin{pmatrix} (1-l/f_1)^2 & 2l(1-l/f_1) & l^2 \\ (1-l/f_2)^2 & 2l(1-l/f_2) & l^2 \\ (1-l/f_3)^2 & 2l(1-l/f_3) & l^2 \\ (1-l/f_4)^2 & 2l(1-l/f_4) & l^2 \\ (1-l/f_5)^2 & 2l(1-l/f_5) & l^2 \end{pmatrix} \begin{pmatrix} \sigma_{11} \\ \sigma_{12} \\ \sigma_{22} \end{pmatrix}$$

$$\begin{pmatrix} \frac{\bar{\sigma}_{x,1}^2}{\Sigma_1} \\ \frac{\bar{\sigma}_{x,2}^2}{\Sigma_2} \\ \frac{\bar{\sigma}_{x,3}^2}{\Sigma_3} \\ \frac{\bar{\sigma}_{x,4}^2}{\Sigma_4} \\ \frac{\bar{\sigma}_{x,5}^2}{\Sigma_5} \end{pmatrix} = \begin{pmatrix} \frac{(1-l/f_1)^2}{\Sigma_1} & \frac{2l(1-l/f_1)}{\Sigma_1} & \frac{l^2}{\Sigma_1} \\ \frac{(1-l/f_2)^2}{\Sigma_2} & \frac{2l(1-l/f_2)}{\Sigma_2} & \frac{l^2}{\Sigma_2} \\ \frac{(1-l/f_3)^2}{\Sigma_3} & \frac{2l(1-l/f_3)}{\Sigma_3} & \frac{l^2}{\Sigma_3} \\ \frac{(1-l/f_4)^2}{\Sigma_4} & \frac{2l(1-l/f_4)}{\Sigma_4} & \frac{l^2}{\Sigma_4} \\ \frac{(1-l/f_5)^2}{\Sigma_5} & \frac{2l(1-l/f_5)}{\Sigma_5} & \frac{l^2}{\Sigma_5} \end{pmatrix} \begin{pmatrix} \sigma_{11} \\ \sigma_{12} \\ \sigma_{22} \end{pmatrix}$$

- Solve by least-squares pseudo-inverse

$$x=(A^tA)^{-1}A^ty$$

- with the covariance matrix $Cov=(A^tA)^{-1}$
 - diagonal elements are square of error bars of fit parameter x



Or use several wire scanners

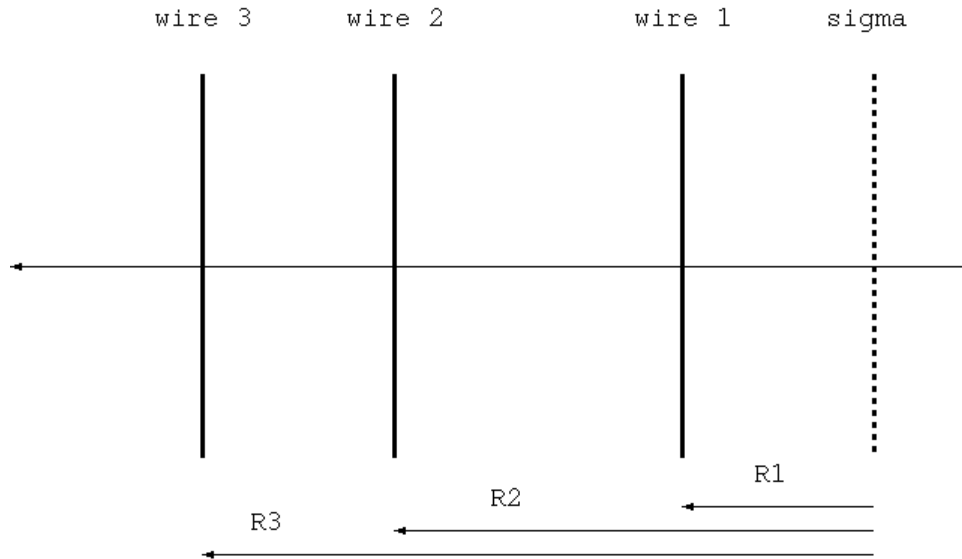

$$\bar{\sigma}_1^2 = (R^1)_{11}^2 \sigma_{11} + 2R_{11}^1 R_{12}^1 \sigma_{12} + (R^1)_{12}^2 \sigma_{22}$$

$$\bar{\sigma}_2^2 = (R^2)_{11}^2 \sigma_{11} + 2R_{11}^2 R_{12}^2 \sigma_{12} + (R^2)_{12}^2 \sigma_{22}$$

$$\bar{\sigma}_3^2 = (R^3)_{11}^2 \sigma_{11} + 2R_{11}^3 R_{12}^3 \sigma_{12} + (R^3)_{12}^2 \sigma_{22}$$

$$\begin{pmatrix} \bar{\sigma}_1^2 \\ \bar{\sigma}_2^2 \\ \bar{\sigma}_3^2 \end{pmatrix} = \begin{pmatrix} (R^1)_{11}^2 & 2R_{11}^1 R_{12}^1 & (R^1)_{12}^2 \\ (R^2)_{11}^2 & 2R_{11}^2 R_{12}^2 & (R^2)_{12}^2 \\ (R^3)_{11}^2 & 2R_{11}^3 R_{12}^3 & (R^3)_{12}^2 \end{pmatrix} \begin{pmatrix} \sigma_{11} \\ \sigma_{12} \\ \sigma_{22} \end{pmatrix}$$

- $(A^t A)^{-1} A^t$ - gymnastics with error bar estimates
- Derive emittance in same way, once σ_{ij} is found by inversion
- Can use several more wire scanners which allows χ^2 calculation for goodness-of-fit estimate



DIY: emittance from three wire scanners in software

```
% three_wire_scanners.m
:
beamline=.. % define the beamline
[Racc, spos, nmat, nlines]=calcmat(beamline);
p0=.. % Reference position
cor=[w1,w2,w3]; % table of three wire scanners

R1=Racc(:, :, w1)*inv(Racc(:, :, p0-1));
R2=Racc(:, :, w2)*inv(Racc(:, :, p0-1));
R3=Racc(:, :, w3)*inv(Racc(:, :, p0-1));

A=[R1(1,1)^2, 2*R1(1,1)*R1(1,2), R1(1,2)^2 ;
   R2(1,1)^2, 2*R2(1,1)*R2(1,2), R2(1,2)^2 ;
   R3(1,1)^2, 2*R3(1,1)*R3(1,2), R3(1,2)^2]

sigx=[sig1;sig2;sig3]; % measurements
sigma0=inv(A)*(sigx.^2) % sigma/beam matrix at p0

eps=sqrt(sigma0(1)*sigma0(3)-sigma0(2)^2);
beta=sigma0(1)/eps;
alfa=-sigma0(2)/eps;
```

$$\begin{pmatrix} \bar{\sigma}_1^2 \\ \bar{\sigma}_2^2 \\ \bar{\sigma}_3^2 \end{pmatrix} = \begin{pmatrix} (R^1)_{11}^2 & 2R_{11}^1 R_{12}^1 & (R^1)_{12}^2 \\ (R^2)_{11}^2 & 2R_{11}^2 R_{12}^2 & (R^2)_{12}^2 \\ (R^3)_{11}^2 & 2R_{11}^3 R_{12}^3 & (R^3)_{12}^2 \end{pmatrix} \begin{pmatrix} \sigma_{11} \\ \sigma_{12} \\ \sigma_{22} \end{pmatrix}$$

- Beam line
- Positions
- Transfer matrices
- Matrix A
- σ_0 at reference
- Extract ε , β , α

$$\varepsilon_x^2 = \sigma_{11}\sigma_{22} - \sigma_{12}^2 \quad \beta_x = \sigma_{11}/\varepsilon_x \quad \alpha_x = -\sigma_{12}/\varepsilon_x$$



Fix beam matrix a.k.a. Beta match

- Uncoupled beam matrix

$$\varepsilon_x \begin{pmatrix} \beta_x & -\alpha_x \\ -\alpha_x & \gamma_x \end{pmatrix} \quad \gamma_x = \frac{1 + \alpha_x^2}{\beta_x}$$

- need four quadrupoles to adjust $\alpha_x, \beta_x, \alpha_y,$ and β_y
- non-linear optimizer (MADX matching module)

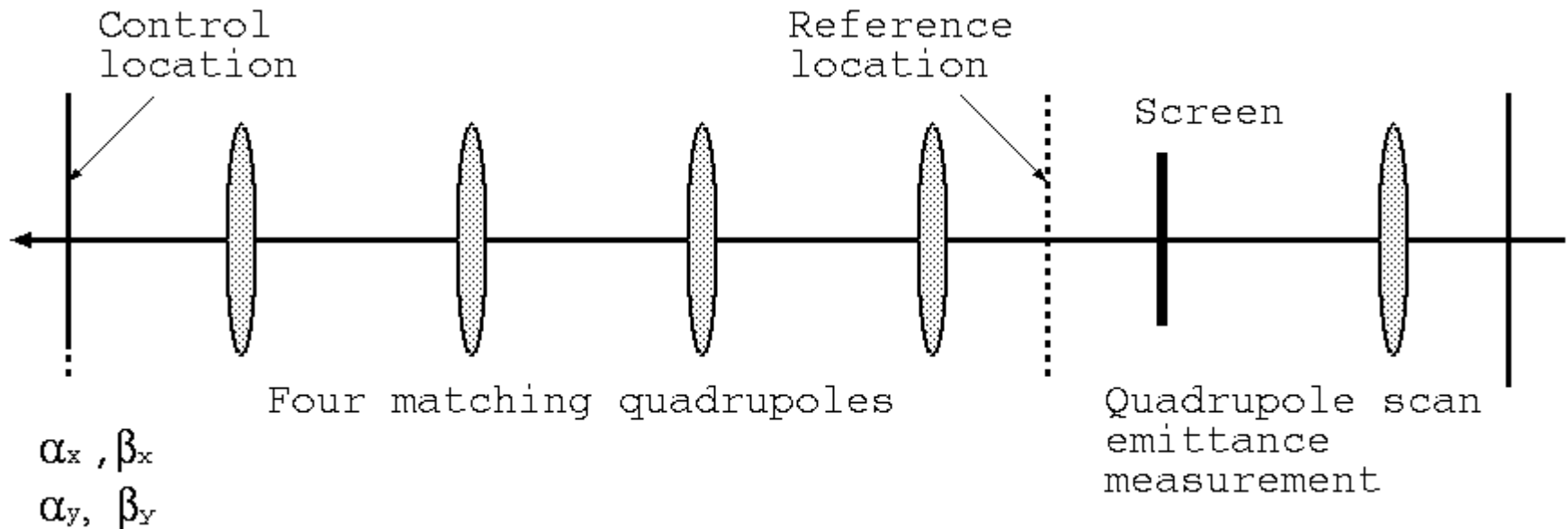



Waist knob

- Finding quad-excitations to match beta functions (or sigma matrix) is a non-linear problem
- and depends on the incoming beam matrix.
- Tricky, but one sometimes can build knobs, based on the design optics, to correct some observable
 - conceptually: linearizing around a working point
- Example:
 - IP-waist knob
 - $d\alpha_x/dQ_{1,2}$ and $d\alpha_y/dQ_{1,2}$



Beam lines: Skew-gradient errors

- Transfer matrix for a skew-quadrupole
- Vertical part of the sigma-matrix after skew quad

$$S = \begin{pmatrix} 1 & 0 & 0 & 0 \\ 0 & 1 & 1/f & 0 \\ 0 & 0 & 1 & 0 \\ 1/f & 0 & 0 & 1 \end{pmatrix}$$

$$\begin{pmatrix} \hat{\sigma}_{33} & \hat{\sigma}_{34} \\ \hat{\sigma}_{34} & \hat{\sigma}_{44} \end{pmatrix} = \begin{pmatrix} \sigma_{33} & \sigma_{34} \\ \sigma_{34} & \sigma_{44} + \sigma_{11}/f^2 \end{pmatrix}$$

- *Projected emittance* after skew quadrupole

$$\hat{\varepsilon}_y^2 = \varepsilon_y^2 + \frac{\sigma_{11}\sigma_{33}}{f^2} = \varepsilon_y^2 \left(1 + \frac{\varepsilon_x}{\varepsilon_y} \frac{\beta_x \beta_y}{f^2} \right)$$

- Problem with flat beams. Increases with ratio $\varepsilon_x/\varepsilon_y$ and is proportional to both beta functions.
- Problem in Final-Focus Systems with flat beams. Solenoid fields need compensation.



Imperfections in a Ring

- Effect of a localized kick on orbit
- Effect of a localized gradient error
- Effect of a skew gradient error
- Stop-bands and resonances

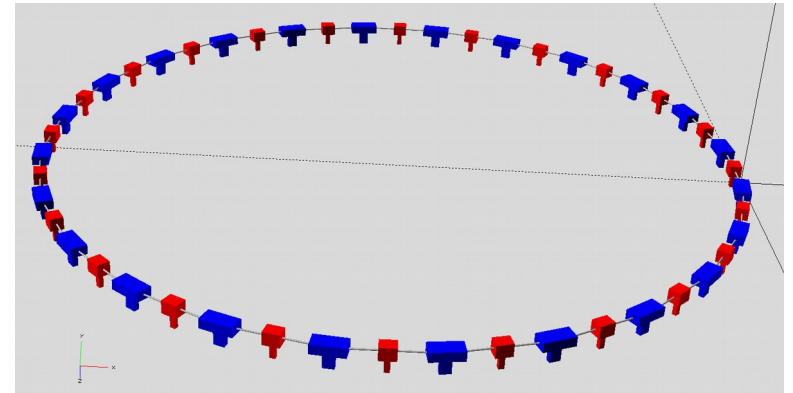



Dipole errors in a Ring

- Beam bites its tail → periodic boundary conditions
→ closed orbit

- Orbit after perturbation at j

$$\vec{x}_j = R^{jj} \vec{x}_j + \vec{q}_j$$

$$\vec{x}_j = (1 - R^{jj})^{-1} \vec{q}_j$$

- Propagate to BPM i

$$\vec{x}_i = R^{ij} \vec{x}_j = R^{ij} (1 - R^{jj})^{-1} \vec{q}_j = C^{ij} \vec{q}_j$$

- Response coefficients $C^{ij} = R^{ij} (1 - R^{jj})^{-1}$

- just like transfer matrix in beam line, but with built-in closed-orbit constraint.

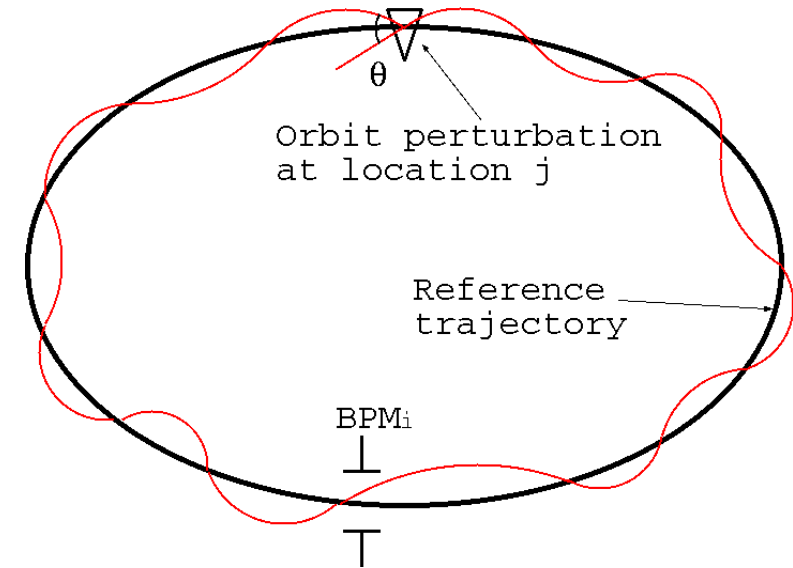



DIY: response coefficients

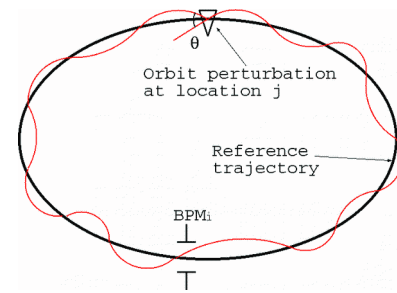

Depends how matrices in Racc are organized:

$$R_{jj} = (\text{Start2COR}) * (\text{Start2End}) * \text{inv}(\text{Start2COR})$$

and

R_{ij} depends on whether BPM(i) is upstream or downstream of corrector(j)

```
% CC.m, BPM-COR response matrix in ring
function out=CC(ipos,jpos,Racc)
Rjj=Racc(:, :, jpos)*Racc(:, :, end)*inv(Racc(:, :, jpos));
if ipos > jpos
    Rij=Racc(:, :, ipos)*inv(Racc(:, :, jpos));
else
    Rij=Racc(:, :, ipos)*Racc(:, :, end)*inv(Racc(:, :, jpos));
end
out=Rij*(inv(eye(4)-Rjj));
```

$$C^{ij} = R^{ij} (1 - R^{jj})^{-1}$$

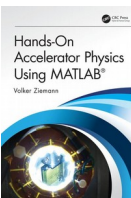



Response coefficients with beta functions

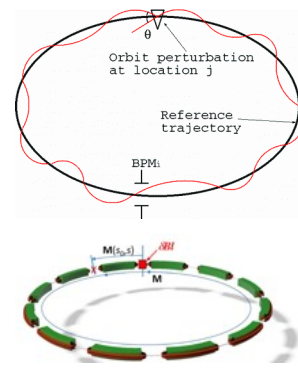

- Express transfer-matrices through beta functions

$$\begin{pmatrix} x \\ x' \end{pmatrix}_j = \begin{pmatrix} \cos(2\pi Q) & \beta_j \sin(2\pi Q) \\ -\sin(2\pi Q)/\beta_j & \cos(2\pi Q) \end{pmatrix} \begin{pmatrix} x \\ x' \end{pmatrix}_j + \begin{pmatrix} 0 \\ \theta \end{pmatrix}$$

- Solve for closed orbit

$$\begin{pmatrix} x \\ x' \end{pmatrix}_j = \frac{\theta}{2} \begin{pmatrix} \beta_j \cot(\pi Q) \\ 1 \end{pmatrix}$$

- Transfer matrix to BPM i

$$R^{ij} = \begin{pmatrix} \sqrt{\beta_i} & 0 \\ -\alpha_i/\sqrt{\beta_i} & 1/\sqrt{\beta_i} \end{pmatrix} \begin{pmatrix} \cos \mu_{ij} & \sin \mu_{ij} \\ -\sin \mu_{ij} & \cos \mu_{ij} \end{pmatrix} \begin{pmatrix} 1/\sqrt{\beta_j} & 0 \\ 0 & \sqrt{\beta_j} \end{pmatrix}$$

- Response coefficient

$$x_i = \left[\frac{\sqrt{\beta_i \beta_j}}{2 \sin(\pi Q)} \cos(\mu_{ij} - \pi Q) \right] \theta$$

Divergences
at integer tunes

$$C_{12}^{ij} = \frac{\partial BPM_i(x)}{\partial COR_j(x')}$$



Quadrupole alignment amplification factor

- Consider randomly displaced quadrupoles

$$\theta_j = d_j/f \quad \langle d_j \rangle = 0 \quad \langle d_j d_k \rangle = \sigma_d^2 \delta_{jk}$$

- Incoherently (RMS) add all contributions

$$\begin{aligned} \langle x_i^2 \rangle &= \left\langle \left[\sum_j \frac{\sqrt{\beta_i \beta_j}}{2 \sin \pi Q} \cos(\mu_{ij} - \pi Q) \frac{d_j}{f_j} \right] \left[\sum_k \frac{\sqrt{\beta_i \beta_k}}{2 \sin \pi Q} \cos(\mu_{ik} - \pi Q) \frac{d_k}{f_k} \right] \right\rangle \\ &= \sum_j \frac{\beta_i \beta_j}{(2 \sin \pi Q)^2} \cos^2(\mu_{ij} - \pi Q) \frac{\sigma_d^2}{f_j^2} \end{aligned}$$

- Misalignment amplification factor $\sqrt{\langle x_i^2 \rangle} \approx \sqrt{N_q} \frac{\bar{\beta}/\bar{f}}{2\sqrt{2} \sin \pi Q} \sigma_d$
 - large rings with large N_q are sensitive
 - such as LHC and FCC



Response Coefficients with RF

- Radio-frequency system constrains the revolution time

$$\frac{\Delta T}{T} = \frac{\Delta C}{C} - \frac{\Delta v}{v} = \left(\alpha - \frac{1}{\gamma^2} \right) \delta$$

- but a horizontal kick causes a horizontal closed orbit distortion which causes the circumference to change by $\Delta C = D_x \theta_x$
(6x6 TM is symplectic, and if uncoupled: $R_{16}=R_{52}$)

- Since RF fixes the revolution frequency the momentum of the particle has to adjust to $\delta = -D_j \theta / \eta C$

- ...and the particle moves on a dispersion trajectory

- Complete response coefficient between BPM_i and dipole error or COR_j

$$C_{12}^{ij} = \left[\frac{\sqrt{\beta_i \beta_j}}{2 \sin(\pi Q)} \cos(\mu_{ij} - \pi Q) - \frac{D_i D_j}{\eta C} \right]$$



Orbit Correction in a Ring

- Every steering magnet affects every BPM
 - orbit response coefficients and matrix $C^{ij} = R^{ij}(1 - R^{jj})^{-1}$
- Compensate measured positions x_i by inverting

$$\begin{pmatrix} -x_1 \\ -x_2 \\ \vdots \\ -x_m \end{pmatrix} = \begin{pmatrix} C_{12}^{11} & C_{12}^{12} & \dots & C_{12}^{1n} \\ C_{12}^{21} & C_{12}^{22} & \dots & C_{12}^{2n} \\ \vdots & \vdots & \ddots & \vdots \\ C_{12}^{m1} & C_{12}^{m2} & \dots & C_{12}^{mn} \end{pmatrix} \begin{pmatrix} \theta_1 \\ \theta_2 \\ \vdots \\ \theta_n \end{pmatrix}$$

- and also in the vertical plane
- left-multiply with diagonal BPM error matrix $\bar{\Lambda} = \text{diag}\left(\frac{1}{\sigma_1}, \dots, \frac{1}{\sigma_n}\right)$
- use either calculated or measured response matrix
- inversion with pseudo-inverse, MICADO, or SVD



DIY: BPM-COR matrix

- Receive table of BPM and corrector positions as input. Is based on Racc.
- Loops over all combinations and returns Cx and Cy (uncoupled)

```
% response_coefficients.m
function [Cx,Cy]=response_coefficients(bpmpos,corpos,Racc)
nbpm=length(bpmpos); ncor=length(corpos);
Cx=zeros(nbpm,ncor); Cy=Cx;
for ibpm=1:nbpm
    for icor=1:ncor
        C=CC(bpmpos(ibpm),corpos(icolor),Racc);
        Cx(ibpm,icolor)=C(1,2);
        Cy(ibpm,icolor)=C(3,4);
    end
end
end
```



Example: orbit correction

Vertical orbit in LHC, before and after correction

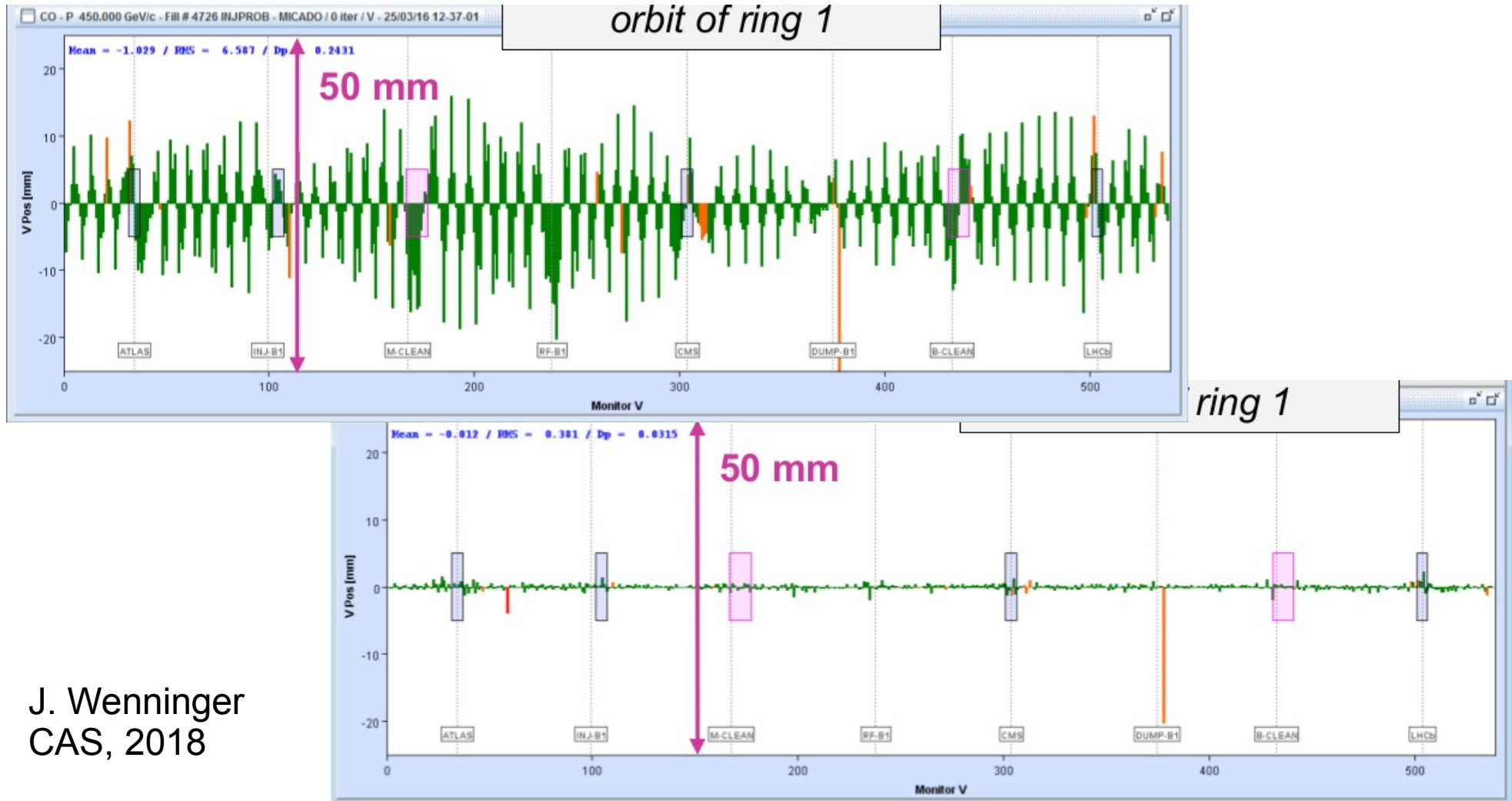

J. Wenninger
CAS, 2018

Steering synchrotron beam lines

- steer synchrotron light beam onto experiment
- fix angle at source point
- incorporate in orbit correction by $+L, vBPM, -L$

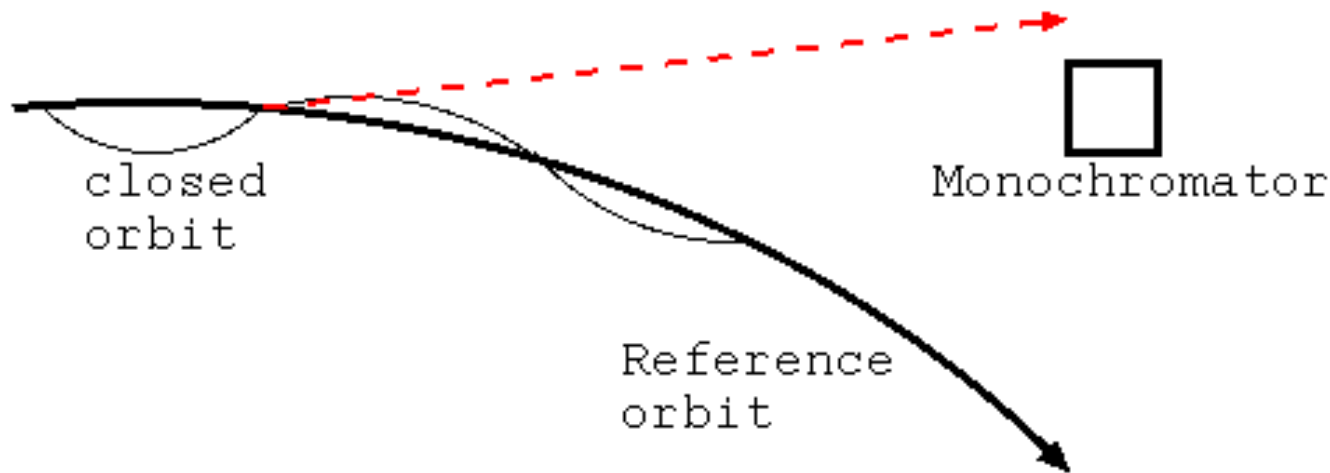



Dispersion-free steering

- Steering magnets are small dipoles and also affect the dispersion (in ring and linac) besides the orbit.
- Take into account with dispersion response matrix $S_{ij} = dD_i/d\theta_j = d^2x_i/d\delta d\theta_j$ ($D_i = dx_i/d\delta$)
 - Either numerically or from measurements
- Simultaneously correct orbit and dispersion
 - weight with Σ s
 - more constraints
 - same number of correctors

$$\begin{pmatrix} \vdots \\ x_i/\Sigma_i \\ \vdots \\ D_i/\hat{\Sigma}_i \\ \vdots \end{pmatrix} = \begin{pmatrix} C_{ij}/\Sigma_i \\ S_{ij}/\hat{\Sigma}_i \end{pmatrix} \begin{pmatrix} \vdots \\ \theta_j \\ \vdots \end{pmatrix}$$



Gradient Errors in a Ring

- Add a gradient error (modeled as a thin quad) to a ring with $\mu=2\pi Q$

$$R_Q R = \begin{pmatrix} 1 & 0 \\ -1/f & 1 \end{pmatrix} \begin{pmatrix} \cos \mu + \alpha \sin \mu & \beta \sin \mu \\ -\frac{1+\alpha^2}{\beta} \sin \mu & \cos \mu - \alpha \sin \mu \end{pmatrix}$$

$$= \begin{pmatrix} \cos \mu + \alpha \sin \mu & \beta \sin \mu \\ -(\cos \mu + \alpha \sin \mu)/f + \gamma \sin \mu & \cos \mu - \alpha \sin \mu - (\beta/f) \sin \mu \end{pmatrix}$$

- Trace gives the perturbed tune $\bar{Q} = Q + \Delta Q$

$$2 \cos(2\pi(Q + \Delta Q)) = 2 \cos(2\pi Q) - \frac{\beta}{f} \sin(2\pi Q)$$

- and if β/f is small: the tune-shift is $\Delta Q \approx \frac{\beta}{4\pi f}$
- Gradient errors change the tune!



Changes of the beta function and stop bands

- From R_{12} get the change in the beta function

$$\bar{\beta} = \frac{\beta \sin(2\pi Q)}{\sin(2\pi(Q + \Delta Q))} \approx \beta [1 + 2\pi \Delta Q \cot(2\pi Q)]$$

$$\frac{\Delta\beta}{\beta} = 2\pi \Delta Q \cot(2\pi Q) \approx \frac{\beta}{2f} \cot(2\pi Q)$$

- Divergences at half-integer values of the tune
- Stability requires

$$\left| \cos(2\pi Q) - \frac{\beta}{2f} \sin(2\pi Q) \right| \leq 1$$

- stop-band width

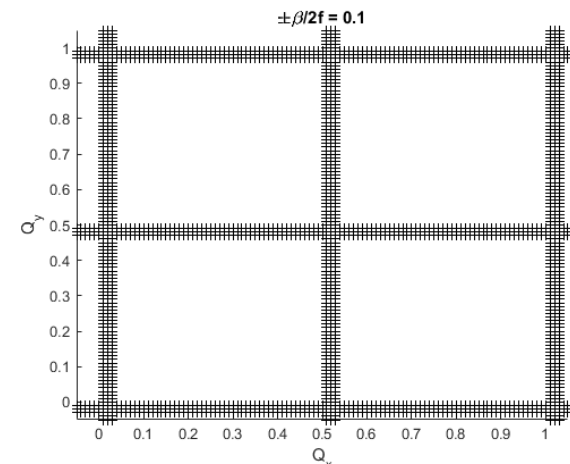



DIY: preparing the plot

```
% stopband_quad.m
clear all; close all
dmu=0.1; % beta/2f
hold on
for Qx=-0.05:0.01:1.05;
    tx=abs(cos(2*pi*Qx)+dmu*sin(2*pi*Qx));
    for Qy=-0.05:0.01:1.05
        ty=abs(cos(2*pi*Qy)-dmu*sin(2*pi*Qy));
        if (tx>1) plot(Qx,Qy,'k+'); end
        if (ty>1) plot(Qx,Qy,'k+'); end
    end
    pause(0.001)
end
xlim([-0.05,1.05]); ylim([-0.05,1.05]);
xlabel('Q_x'); ylabel('Q_y')
```

- Choose $d\mu=\beta/2f$ of the additional quadrupole
- Loop over all tunes Q_x and Q_y
- and check whether
$$\left| \cos(2\pi Q) - \frac{\beta}{2f} \sin(2\pi Q) \right| \leq 1$$
in both planes.
- Draw plus sign if the condition is violated.



Measuring the Tune

- Kick beam and look at BPM difference-signal on spectrum analyzer
 - and divide frequency by revolution frequency gives fractional part of the tune
- Turn by turn BPM recordings and FFT
 - is it Q or $1-Q$?
 - change QF and see which way the tune moves
- PLL in LHC: Beam is band-pass, tickle it, and detect synchronously

```
Qx=0.616;  
n=1:1024;  
x=sin(2*pi*Qx*n);  
plot(n/1024,abs(fft(x)));  
xlabel('Q_x'); ylabel('|fft(x)|')
```

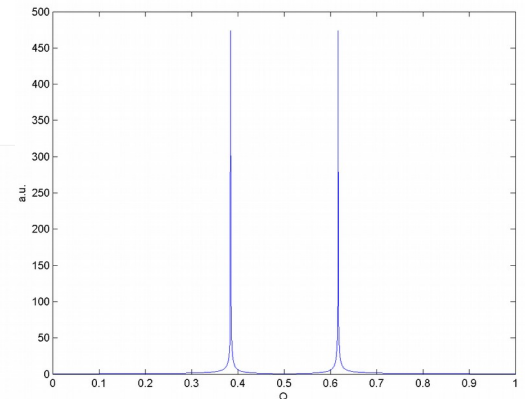



Tune Correction

- Use a variable quadrupole with $1/f = \Delta k_1/l$

- Changes both Q_x and Q_y $\Delta Q_x = \frac{\beta_{1x}}{4\pi f_1}$ and $\Delta Q_y = -\frac{\beta_{1y}}{4\pi f_1}$

- Use two independent quadrupoles

$$\begin{aligned} \Delta Q_x &= \frac{\beta_{1x}}{4\pi f_1} + \frac{\beta_{2x}}{4\pi f_2} \\ \Delta Q_y &= -\frac{\beta_{1y}}{4\pi f_1} - \frac{\beta_{2y}}{4\pi f_2} \end{aligned} \quad \begin{pmatrix} \Delta Q_x \\ \Delta Q_y \end{pmatrix} = \frac{1}{4\pi} \begin{pmatrix} \beta_{1x} & \beta_{2x} \\ -\beta_{1y} & -\beta_{2y} \end{pmatrix} \begin{pmatrix} 1/f_1 \\ 1/f_2 \end{pmatrix}$$

- Solve by inversion

$$\begin{pmatrix} 1/f_1 \\ 1/f_2 \end{pmatrix} = \frac{-4\pi}{\beta_{1x}\beta_{2y} - \beta_{2x}\beta_{1y}} \begin{pmatrix} -\beta_{2y} & -\beta_{2x} \\ \beta_{1y} & \beta_{1x} \end{pmatrix} \begin{pmatrix} \Delta Q_x \\ \Delta Q_y \end{pmatrix}$$

- Quads on same power supply \rightarrow sum of betas



Measuring beta functions

- Change quadrupole and observe tune variation

$$\Delta Q_x = \frac{\beta_{1x}}{4\pi f_1} \quad \text{and} \quad \Delta Q_y = -\frac{\beta_{1y}}{4\pi f_1}$$

- Need independent power supplies
 - or piggy-back boost supply
 - or a shunt resistor
- May get sums of betas in quads-on-the-same-power-supply.



Model Calibration #1

- Compare measured \hat{C}^{ij} orbit response matrix to computer model C^{ij}
 - enormous amount of data $2 \times N_{\text{bpm}} \times N_{\text{cor}}$
- and blame the difference on quad gradients g_k or other parameters p_l
 - much fewer fit-parameters N_{quad} and N_{para}

$$\hat{C}^{ij} - C^{ij} = \sum_k \frac{\partial C^{ij}}{\partial g_k} \Delta g_k + \sum_l \frac{\partial C^{ij}}{\partial p_l} \Delta p_l$$

- First used in SPEAR and later perfected in NSLS → LOCO



Model Calibration #2

UPPSALA
UNIVERSITET

- Normally the parameters p_i are BPM and corrector scale errors
 - fit for N_{quad} gradients and $2 \times (N_{\text{bpm}} + N_{\text{cor}})$ scales

$$\hat{C}^{ij} - C^{ij} = \sum_k \frac{\partial C^{ij}}{\partial g_k} \Delta g_k + C^{ij} \Delta x^i - C^{ij} \Delta y^j$$

- Determine derivatives $\partial C^{ij} / \partial g_k$ numerically by changing a gradient and re-calculating all response coefficients, then taking differences
- BPM-cor degeneracy \rightarrow SVD needed to invert
- Converges, if χ^2/DOF is close to unity



micro-LOCO

- 2 Quads, 2 BPM, 2 COR, only horizontal “ C_{12} ”
 - ill-defined, but useful to see the structure of matrix
 - gradient errors Δg , BPM scales Δx , corrector scales Δy
- Blame difference on $\Delta g, \Delta x, \Delta y$ $C^{ij} = R^{ij}(1 - R^{jj})^{-1}$

$$\begin{pmatrix} \hat{C}^{11} - C^{11} \\ \hat{C}^{21} - C^{21} \\ \hat{C}^{12} - C^{12} \\ \hat{C}^{22} - C^{22} \end{pmatrix} = \begin{pmatrix} \frac{\partial C^{11}}{\partial g_1} & \frac{\partial C^{11}}{\partial g_2} & C^{11} & 0 & -C^{11} & 0 \\ \frac{\partial C^{21}}{\partial g_1} & \frac{\partial C^{21}}{\partial g_2} & 0 & C^{21} & -C^{21} & 0 \\ \frac{\partial C^{12}}{\partial g_1} & \frac{\partial C^{12}}{\partial g_2} & C^{12} & 0 & 0 & -C^{12} \\ \frac{\partial C^{22}}{\partial g_1} & \frac{\partial C^{22}}{\partial g_2} & 0 & C^{22} & 0 & -C^{22} \end{pmatrix} \begin{pmatrix} \Delta g_1 \\ \Delta g_2 \\ \Delta x_1 \\ \Delta x_2 \\ \Delta y_1 \\ \Delta y_2 \end{pmatrix}$$



DIY: Response matrix analysis

Here: fit for gradients only!
No BPM or corrector scale factors.

```
% micro_loco_example.m, fit for gradients only
:
%.....unperturbed response coefficients
[Cx0,Cy0]=response_coefficients(bpmpos,corpos,Racc);

%.....artificially perturb response coefficients
beamline(2,4)=beamline(2,4)+0.2; % first quad, QF
[Racc,spos,nmat,nlines]=calcmat(beamline); Rend=Racc(:, :,end);
[Cxhat,Cyhat]=response_coefficients(bpmpos,corpos,Racc);
beamline(2,4)=quadf(1); % undo perturbation
dCx=reshape(Cxhat-Cx0,[],1); % store 'measured' as column vector

%.....calculate the derivatives dC/dg
dCdG=zeros(nbpm*ncor,nquad);
dquad=0.1; % perturbation
for iquad=1:nquad
    beamline(qbl(iquad),4)=quadf(iquad)+dquad; % perturb
    [Racc,spos,nmat,nlines]=calcmat(beamline);
    [Cx,Cy]=response_coefficients(bpmpos,corpos,Racc);
    dCdG(:,iquad)=reshape((Cx-Cx0)/dquad,[],1); % column vector
    beamline(qbl(iquad),4)=quadf(iquad); % undo
end

%.....find the perturbed quad values
% (should recover the value of 0.2 from above)
quad_changes=dCdG\dCx
```

The response coefficients of the ideal model

and we mess them up a bit to simulate real data (for example from difference orbits).

reshape brings them in form of a column vector.

Here we numerically calculate the derivatives and store them 'reshaped' one column at a time.

Finally we solve the system (SVD is implicitly used in '\') if needed)

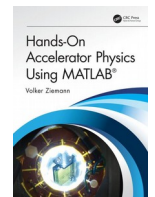



Experience

- SPEAR: could explain measured tunes to within 4×10^{-3} from quadrupole settings which had percent errors (J. Corbett, M. Lee, VZ, PAC93).
- NSLS: LOCO, $\Delta\beta/\beta = 10^{-3}$, dispersion fixed, emittance factor 2 improved (J. Safranek, NIMA 388, 1997)

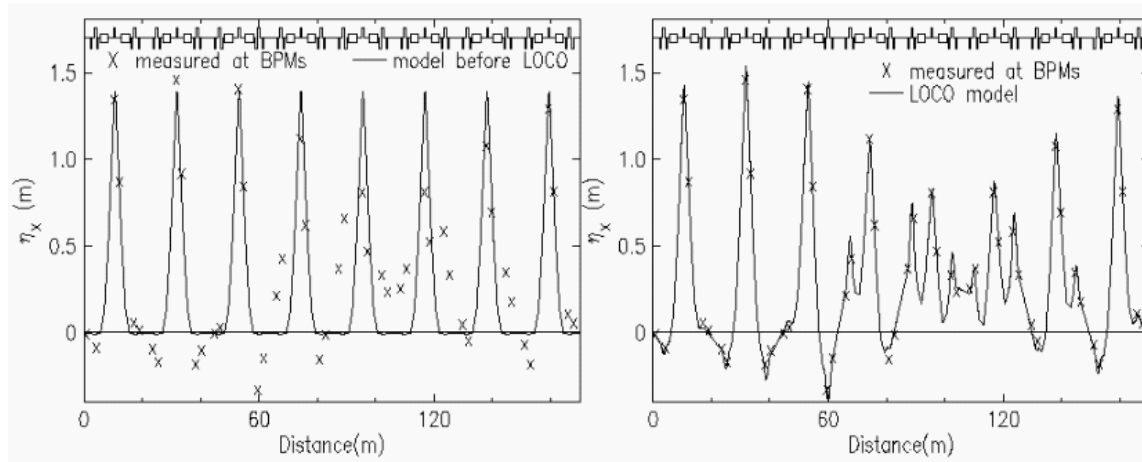

- and practically every light source since then uses it

Skew-gradient stop bands

- Why are skew-gradient errors bad?
 - they also add stop bands along the diagonals
- Ring with single skew
 - with strength $\sqrt{\beta_x \beta_y} / f = 0.2$
- Calculate the eigentunes
 - Edwards-Teng algorithm
- for each pair Q_x, Q_y
- make cross if unstable
 - complex or NAN in Matlab

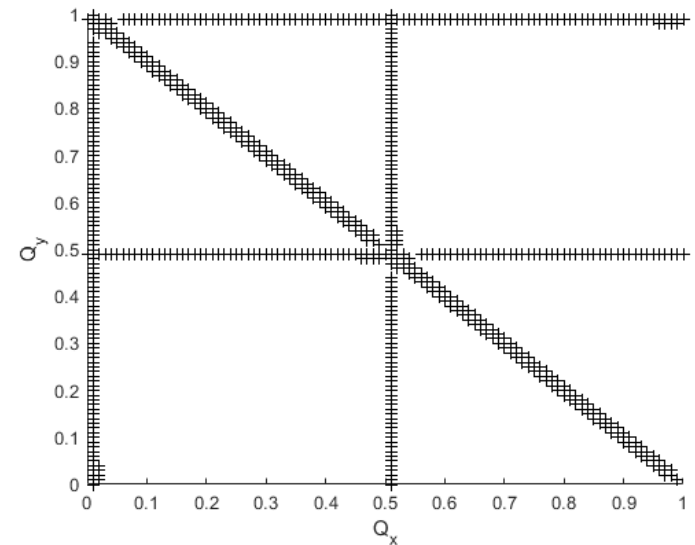



Measuring Coupling

- BPM turn-by-turn data cross talk, beating

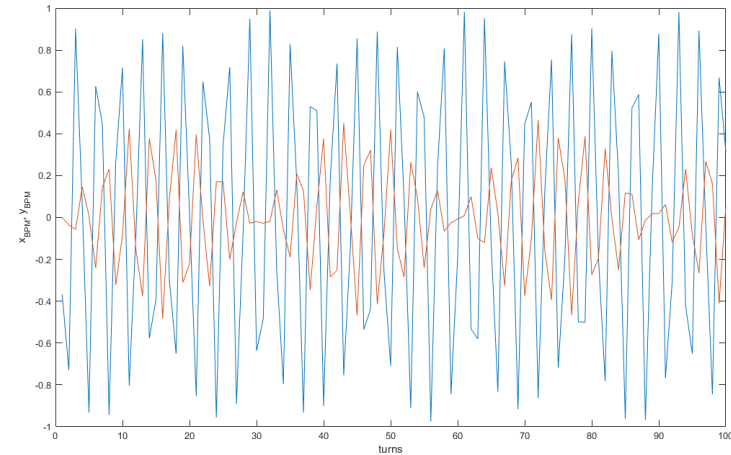
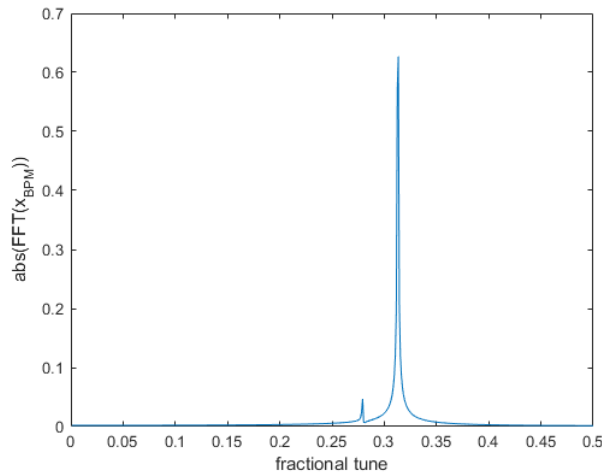

- Closest tune
 - try to make the tunes equal with an upright quad
 - measure tunes
 - coupling 'repels' the tunes

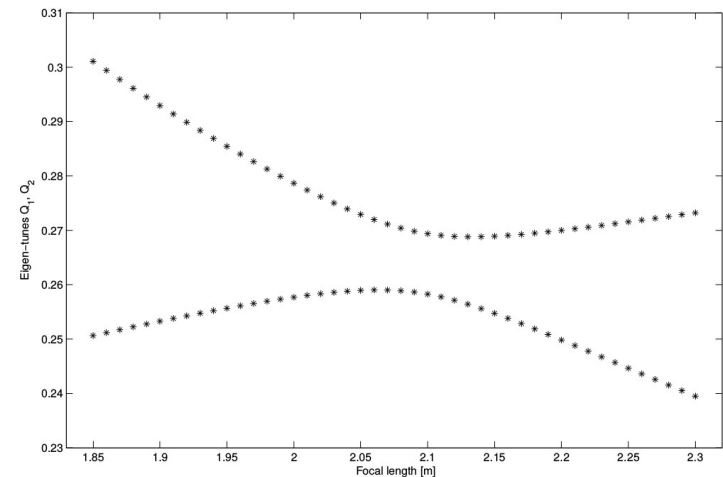



Coupling: mechanical analogy

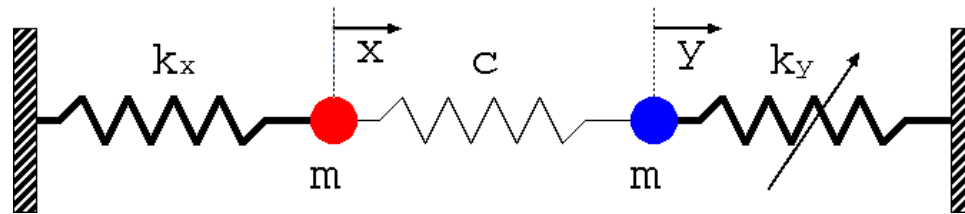

- Two weakly coupled oscillators: simple to find equations of motion

$$0 = m\ddot{x} + (k_x + c)x - cy$$

$$0 = m\ddot{y} + (k_y + c)y - cx$$

- and eigen-frequencies

$$\omega^2 = \frac{k_x + k_y + 2c}{2m} \pm \sqrt{\left(\frac{k_x - k_y}{2m}\right)^2 + \frac{c^2}{m^2}}$$

- Minimum tune separation
- Excite one mass, get beating

Translation for accelerator physicists:

$x \rightarrow$ horiz. betatr. osc.

$y \rightarrow$ vert. betatr. osc.

$k_x/m \rightarrow Q_x^2$

$k_y/m \rightarrow Q_y^2$ (adj.)

$c/m \rightarrow$ coupling source

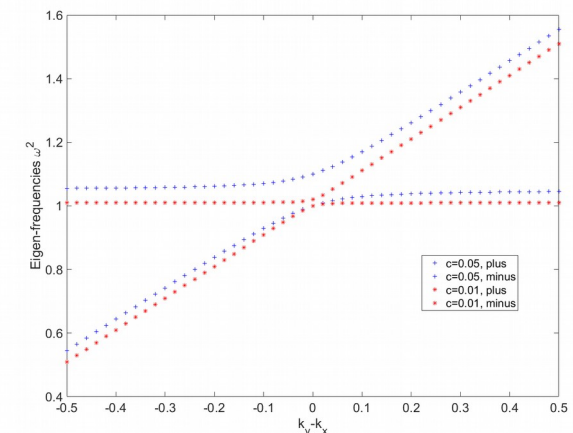



Coupling correction

- Use a single skew-quad if that is all you have to minimize the closest tune.
- Otherwise build knobs for the four resonance-driving terms with normalized skew gradients

$$\begin{pmatrix} \text{Re}(F_-) \\ \text{Im}(F_-) \\ \text{Re}(F_+) \\ \text{Im}(F_+) \end{pmatrix} = \begin{pmatrix} \cos(\mu_{x1} - \mu_{y1}) & \dots & \cos(\mu_{x4} - \mu_{y4}) \\ \sin(\mu_{x1} - \mu_{y1}) & \dots & \sin(\mu_{x4} - \mu_{y4}) \\ \cos(\mu_{x1} + \mu_{y1}) & \dots & \cos(\mu_{x4} + \mu_{y4}) \\ \sin(\mu_{x1} + \mu_{y1}) & \dots & \sin(\mu_{x4} + \mu_{y4}) \end{pmatrix} \begin{pmatrix} \kappa_1 \\ \kappa_2 \\ \kappa_3 \\ \kappa_4 \end{pmatrix}$$

$$F_{\pm} = \sum_j \frac{\beta_{x,j} \beta_{y,j}}{2f_j} e^{i(\mu_{x,j} \pm \mu_{y,j})}$$

$$\kappa_i = \sqrt{\beta_{xi} \beta_{yi}} / 2f_i$$

- and empirically minimize each RDT,
 - often F_- (if tunes are close) is sufficient
- Choose phases μ to make the condition number of the matrix as close to unity as possible.



Measuring Chromaticity Q'

- Chromaticity is the momentum-dependence of the tunes: $Q = Q_0 + Q'\delta$
- Force the momentum to change by changing the RF frequency. The beam follows, because synchrotron oscillations are stable.

$$-\frac{\Delta f_{rf}}{f_{rf}} = \frac{\Delta T}{T} = \eta\delta = \left(\alpha - \frac{1}{\gamma^2}\right)\delta \quad \rightarrow \quad \delta = -\frac{1}{\eta} \frac{\Delta f_{rf}}{f_{rf}}$$

- Plot tune change ΔQ versus $\Delta f_{rf}/f_{rf}$. The slope is proportional to $(1/\text{chromaticity } Q')$ [can also use PLL]

$$Q' = \frac{\Delta Q}{\delta} = -\eta \frac{\Delta Q}{\Delta f_{rf}/f_{rf}}$$



Chromaticity correction

- Need **controllable and momentum-dependent quadrupole** to compensate or at least change the natural chromaticity $Q'=dQ/d\delta$.
- Momentum dependent feed-down: Use sextupole with dispersion, replace d_x by $D_x\delta$

$$\Delta x' - i\Delta y' = \frac{k_2 L}{2} [(x + iy)^2 + 2D_x\delta(x + iy) + D_x^2\delta^2]$$

- Linear (quadrupolar) term with effective focal length that is momentum dependent

$$\frac{1}{f_\delta} = k_2 L D_x \delta$$



Chromaticity correction #2

- Momentum-dependent tune shifts

$$\Delta Q_x = \frac{k_2 L D_x \beta_x}{4\pi} \delta \qquad \Delta Q_y = -\frac{k_2 L D_x \beta_y}{4\pi} \delta$$

- Build correction matrix in the same way as for the tune correction for $\Delta Q' = \Delta Q / \delta$

$$\begin{pmatrix} \Delta Q'_x \\ \Delta Q'_y \end{pmatrix} = \frac{1}{4\pi} \begin{pmatrix} D_{1x} \beta_{1x} & D_{2x} \beta_{2x} \\ -D_{1x} \beta_{1y} & -D_{2x} \beta_{2y} \end{pmatrix} \begin{pmatrix} (k_2 L)_1 \\ (k_2 L)_2 \end{pmatrix}$$

- Invert to find sextupole excitations $k_2 L$ that add chromaticities to partially compensate the natural



Winding down

- We looked at the sources of all evil, the imperfections,
- and how they affect
 - the orbit
 - the optics
- and figured out how to fix it.
- but there are a few bugs that need special attention...



Bloopers

- LEP vacuum pipe soldering
 - Beer bottle in LEP
 - Stand-up metal-piece in magnet
 - Shielding in SLC DR
-
- These non-standard 'imperfections' are very difficult to identify, but it is good to keep in mind that even such odd-balls occur.



UPPSALA
UNIVERSITET

Extra slides



Skew-gradient Errors in a Ring

- Consider a single skew-quad in a ring

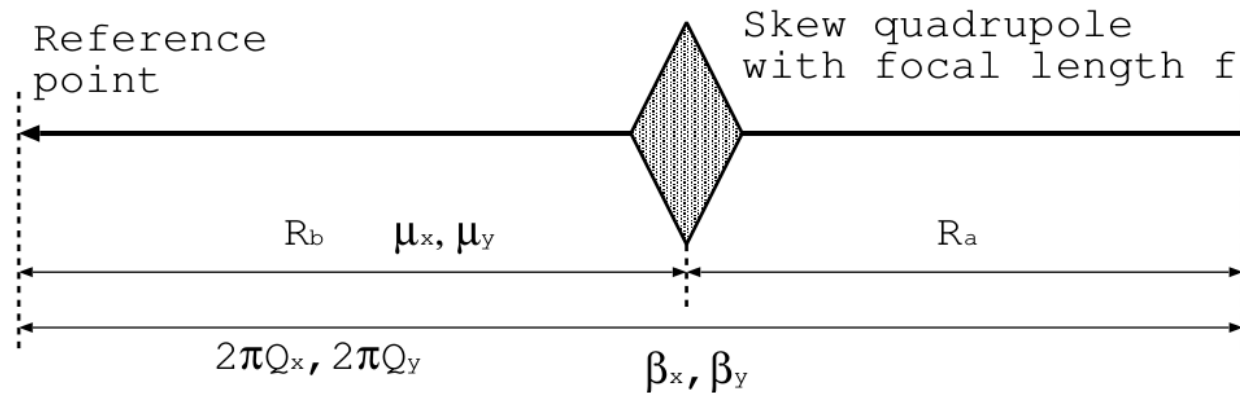

- with 4 x 4 transfer matrix (in NPS)

$$\tilde{S} = \begin{pmatrix} 1_2 & \tilde{Q} \\ \tilde{Q} & 1_2 \end{pmatrix} \quad \tilde{Q} = \begin{pmatrix} 0 & 0 \\ \sqrt{\beta_x \beta_y} / f & 0 \end{pmatrix}$$

- and move the perturbation to a reference point

$$\hat{R} = R_b \tilde{S} R_a = \left(R_b \tilde{S} R_b^{-1} \right) (R_b R_a)$$



Skew-gradient in Ring #2

- Transfer matrix in normalized phase space is rotation, calculate the moved TM

$$R_b \tilde{S} R_b^{-1} = \begin{pmatrix} O_x & 0 \\ 0 & O_y \end{pmatrix} \begin{pmatrix} 1_2 & \tilde{Q} \\ \tilde{Q} & 1_2 \end{pmatrix} \begin{pmatrix} O_x^t & 0 \\ 0 & O_y^t \end{pmatrix} = \begin{pmatrix} 1_2 & O_x \tilde{Q} O_y^{-1} \\ O_y \tilde{Q} O_x^{-1} & 1_2 \end{pmatrix}$$

$$\begin{aligned} O_x \tilde{Q} O_y^{-1} &= \frac{\sqrt{\beta_x \beta_y}}{f} \begin{pmatrix} \sin \mu_x \cos \mu_y & -\sin \mu_x \sin \mu_y \\ \cos \mu_x \cos \mu_y & -\cos \mu_x \sin \mu_y \end{pmatrix} \\ &= \frac{\sqrt{\beta_x \beta_y}}{2f} \begin{pmatrix} \sin(\mu_x - \mu_y) + \sin(\mu_x + \mu_y) & -\cos(\mu_x - \mu_y) + \sin(\mu_x + \mu_y) \\ \cos(\mu_x - \mu_y) + \cos(\mu_x + \mu_y) & \sin(\mu_x - \mu_y) - \sin(\mu_x + \mu_y) \end{pmatrix} \end{aligned} \quad 4!$$

- If many weak skew quads, combine their effect

$$\hat{R} = (1 + \tilde{P}_1)(1 + \tilde{P}_2) \cdots R_0 \approx (1 + \tilde{P}_1 + \tilde{P}_2 + \cdots) R_0$$

- Combinations of sines and cosines may add coherently

$$F_{\pm} = \sum_j \frac{\beta_{x,j} \beta_{y,j}}{2f_j} e^{i(\mu_{x,j} \pm \mu_{y,j})}$$