

Adding New Volumes in Geant4 Baseline Geometry

Status of Agreement AA366/10

Apr 25, 2019



Besik Kekelia

Georgian Technical University

WP1: “Adding New Volumes in Geant4 Baseline Geometry”

To -do List

1. Flexible Chains (sec 11)  Current Project
2. Flexible Chains (sec 15)
3. GAP Outer Services
4. JD Services (sec 13)
5. GAP Middle Services  Moved to WP2
6. CALO Services
7. Platforms in missing Sectors

WP1: “Adding New Volumes in Geant4 Baseline Geometry”

Deliverables:

1. Technical reports of Simplification
2. XML code
3. Technical reports of Integration Conflicts Checking

Detailed Model

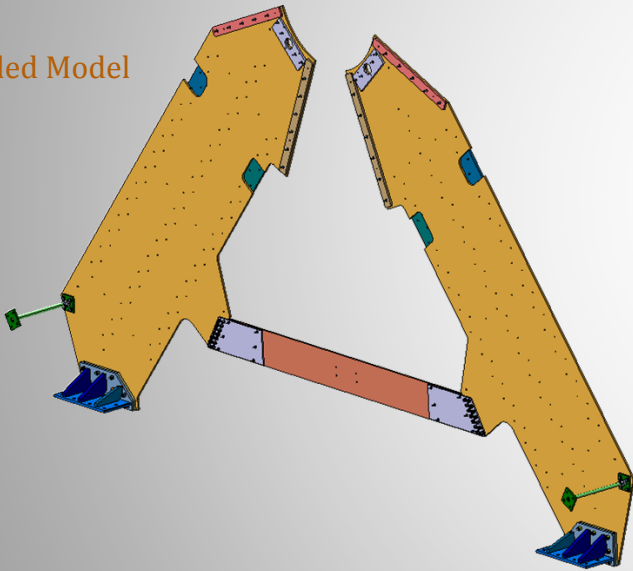

Simplified model

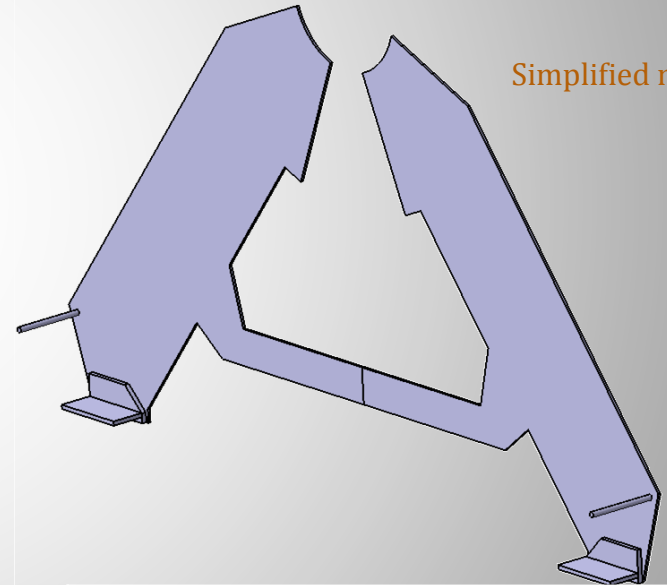

Volume (m³)	0.2562
Mass (kg)	2'049
Material	Stainless Steel
Density (kg/m³)	8000

Volume (m³)	0.256
Mass (kg)	2'048
Material	Stainless Steel
Density (kg/m³)	8000

Flexible Chains (sec 11-15)

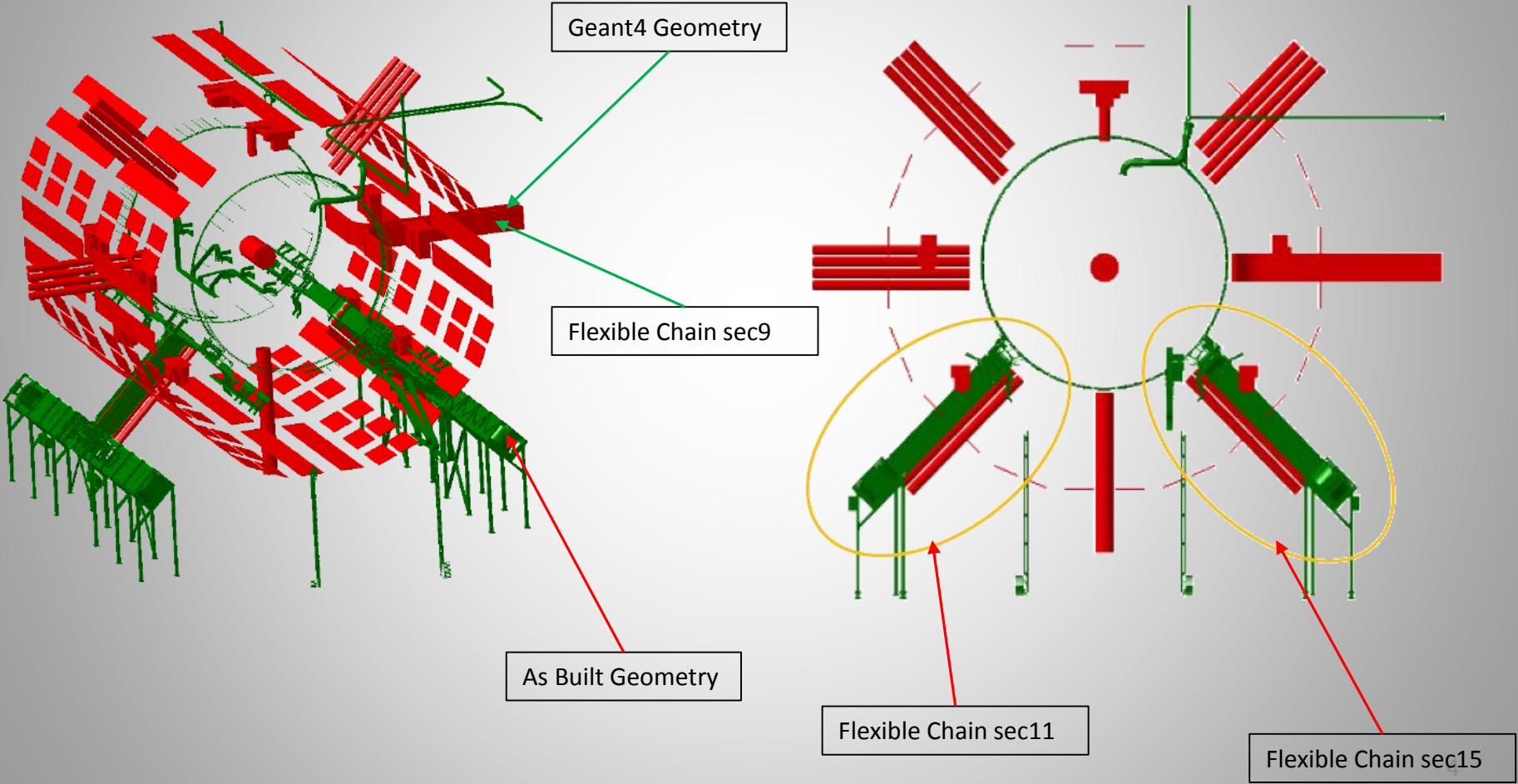

Flexible Cain sec11 - Current

Detailed Model

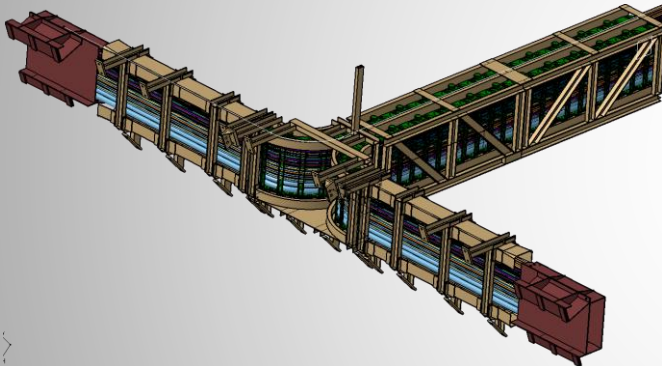

Volume (m ³)	0.518
Mass (kg)	4'193.92
Material	Stainless Steel/Cooper
Density (kg/m ³)	8'000/8960



Simplified model

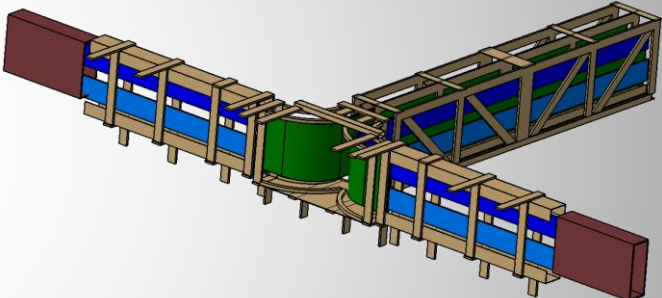

Volume (m ³)	0.518
Mass (kg)	4'193.92
Material	Stainless Steel/Cooper
Density (kg/m ³)	8'000/8960

Diff: 0 Kg

Flexible Cain sec11 - Current

```

<!-- name = Start AGDD section name = "None" -->
</AGDD>
<section name = "Flexible Chain"
  version = "0.0"
  date = "13-09-2017"
  author = "Besik Kekelia"
  top_volume = "Flexible_Chain"
/>
<!-- Flexible Chain (Sec_11) -->
<!-- Piece-->
<box name="Piece_Box" material="ShieldSteel" X_Y_Z="242.; 629.5; 1041."/>
<box name="Piece_cutBox" material="ShieldSteel" X_Y_Z="217.; 600.; 1042."/>
<subtraction name="Piece_subtro" >
  <posXYZ volume="Piece_Box" X_Y_Z=" 0.; 0.; 0." rot=" 0.; 0.; 0."/>
  <posXYZ volume="Piece_cutBox" X_Y_Z=" 0.; 0.; 0." rot=" 0.; 0.; 0."/>
</subtraction>
<composition name="Piece" >
  <posXYZ volume="Piece_subtro" X_Y_Z=" -2902.7; 501.35 ; 3729.5 "/">
  <posXYZ volume="Piece_subtro" X_Y_Z=" -2902.7; 501.35 ; -3729.5 "/">
</composition>
<!-- End Piece-->
<!--Support-->
<!--Central Support-->
<box name="plate_of_support1" material="ShieldSteel" X_Y_Z="4300
] <gvxy name="out_of_plate" material="ShieldSteel" dZ="4315.">
  <gvxy_point X_Y=" -247.5; -53."/>
  <gvxy_point X_Y=" -247.5; 53.775"/>
  <gvxy_point X_Y=" -50.; 53.775"/>
  <gvxy_point X_Y=" -50.; -1.175"/>
  <gvxy_point X_Y=" -42.5; -1.175"/>
  <gvxy_point X_Y=" -42.5; 53.775"/>
  <gvxy_point X_Y=" 42.5; 53.775"/>
  <gvxy_point X_Y=" 42.5; -1.175"/>
  <gvxy_point X_Y=" 50.; -1.175"/>
  <gvxy_point X_Y=" 50.; 53.775"/>
  <gvxy_point X_Y=" 247.5; 53.775"/>
  <gvxy_point X_Y=" 247.5; -53."/>
</gvxy>

```

```

rot=" 0.; 0.; 0."/>
rot=" 0.; 0.; 0."/>
rot=" 0.; 0.; 0."/>
rot=" 0.; 0.; 0."/>
rot=" 0.; 0.; 0."/>
rot=" 0.; 0.; 0."/>
rot=" 0.; 0.; 0."/>
rot=" 0.; 0.; 0."/>
rot=" 0.; 0.; 0."/>
rot=" 0.; 0.; 0."/>
rot=" 0.; 0.; 0."/>
rot=" 0.; 0.; 0."/>
rot=" 0.; 0.; 0."/>
rot=" 0.; 0.; 0."/>
rot=" 0.; 0.; 0."/>
rot=" 0.; 0.; 0."/>
rot=" 0.; 0.; 0."/>
rot=" 0.; 0.; 0."/>
rot=" 0.; 0.; 0."/>
rot=" 0.; 0.; 0."/>
rot=" 0.; 0.; 0."/>
dZ="23.">
X_Y_Z="4112.; 94.; 3."/>
X_Y_Z="100.2; 6.; 620."/>
X_Y_Z="200.; 6.; 620."/>
0.; 0." rot=" 0.; 0.; 0."/>
460.575; 282.5" rot=" 0.; 0.; 0."/>
460.575; 0." rot=" 0.; 0.; 0."/>
467.375; 282.4" rot=" 0.; 0.; 0."/>
074.; 458.8; -282.5" rot=" 0.; 0.; 0."/>
8; 458.8; -282.5" rot=" 0.; 180.; 0."/>
074.; 458.8; -282.5" rot=" 0.; 180.; 0."/>

```

```

<composition name="Cable_assembly" >
  <posXYZ volume="plate_of_Cables" X_Y_Z=" 0.; 0.; 0." rot=" 0.; 0.; 0."/>
  <posXYZ volume="plate_of_Cables2" X_Y_Z=" -2304.55; 0; -417." rot=" 90.; 90.; 0."/>
  <posXYZ volume="plate_of_Cables3" X_Y_Z=" -2721.5; 0.; -2058.05" rot=" 0.; 0.; 0."/>
</composition>
<composition name="Cable" >
  <posXYZ volume="Cable_assembly" X_Y_Z=" -163.09; 624.89; -180." rot=" 0.; 0.; 0."/>
  <posXYZ volume="Cable_assembly" X_Y_Z=" -163.09; 624.89; 180." rot=" 180.; 0.; 0."/>
</composition>
<!--End Cable-->
<!-- Pipes-->
<box name="plate_of_Pipes1" material="ShieldSteel" X_Y_Z="4609.; 240.; 16."/>
<box name="plate_of_Pipes2" material="ShieldSteel" X_Y_Z="409.; 425.; 240." profile="180.; 90." nbPhi="36"/>
<box name="plate_of_Pipes3" material="ShieldSteel" X_Y_Z="16.; 240.; 3282."/>
<composition name="Pipes_assembly" >
  <posXYZ volume="plate_of_Pipes1" X_Y_Z=" 0.; 0.; 0." rot=" 0.; 0.; 0."/>
  <posXYZ volume="plate_of_Pipes2" X_Y_Z=" -2304.55; 0; -417." rot=" 90.; 90.; 0."/>
  <posXYZ volume="plate_of_Pipes3" X_Y_Z=" -2721.5; 0.; -2058.05" rot=" 0.; 0.; 0."/>
</composition>
<composition name="Pipes" >
  <posXYZ volume="Pipes_assembly" X_Y_Z=" -163.09; 324.89; -180." rot=" 0.; 0.; 0."/>
  <posXYZ volume="Pipes_assembly" X_Y_Z=" -163.09; 324.89; 180." rot=" 180.; 0.; 0."/>
</composition>
<!--End Pipes-->
<composition name="Support" >
  <posXYZ volume="central_support" X_Y_Z=" 0.; 0.; 0." rot=" 0.; 0.; 0."/>
  <posXYZ volume="Left Right_support" X_Y_Z=" 0.; 0.; 0." rot=" 0.; 0.; 0."/>
  <posXYZ volume="Middle_Support" X_Y_Z=" -2690.; -7.34; 0." rot=" 0.; 0.; 0."/>
</composition>
<composition name="Flexible_Chain" >
  <posXYZ volume="Piece" X_Y_Z=" 0.; 0.; 0." />
  <posXYZ volume="Support" X_Y_Z=" 0.; 0.; 0." />
  <posXYZ volume="Drag_Chain" X_Y_Z=" 0.; 0.; 0." rot=" 0.; 0.; 0."/>
  <posXYZ volume="Cable" X_Y_Z=" 0.; 0.; 0." rot=" 0.; 0.; 0."/>
  <posXYZ volume="Pipes" X_Y_Z=" 0.; 0.; 0." rot=" 0.; 0.; 0."/>
</composition>
</section>

```

-- Left-
ox name=
ox name=
ox name=
ox name=
ox name=
ox name=

XML code of Flexible Chain sec11

Flexible Cain sec11 - Current

There are Integration Conflict Between Flexible chain(sec 11) and CalorimeterSaddle

Clash = 14.71mm

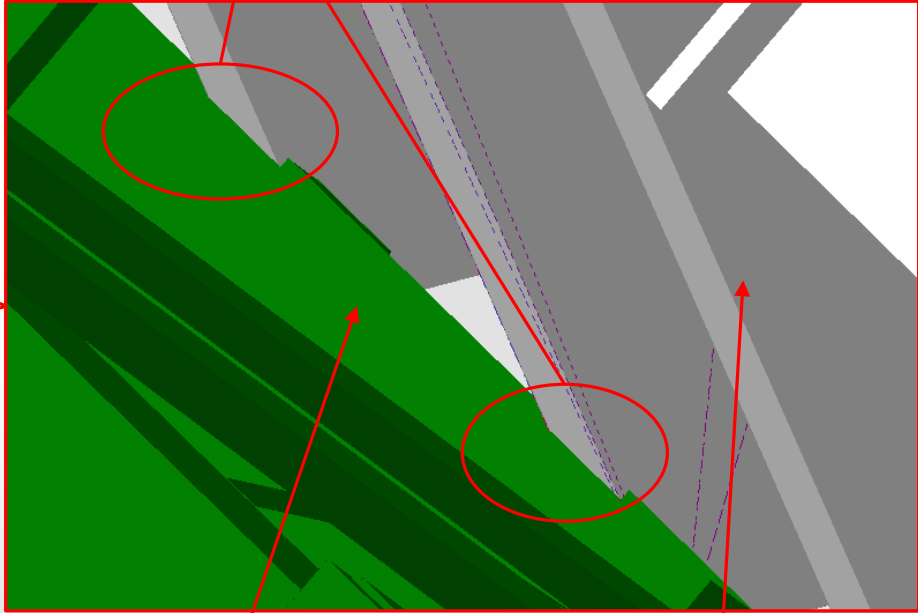

Flexible Chain sec11

Calorimeter Saddle

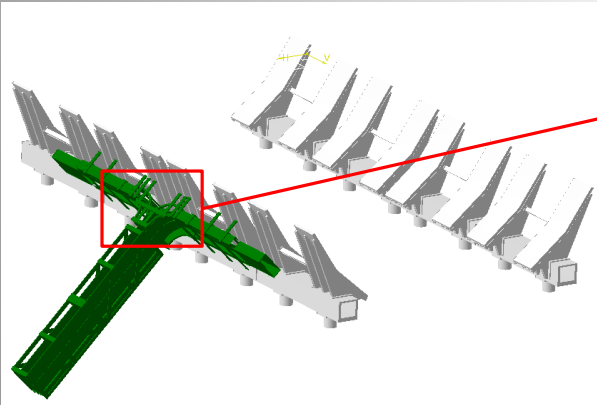
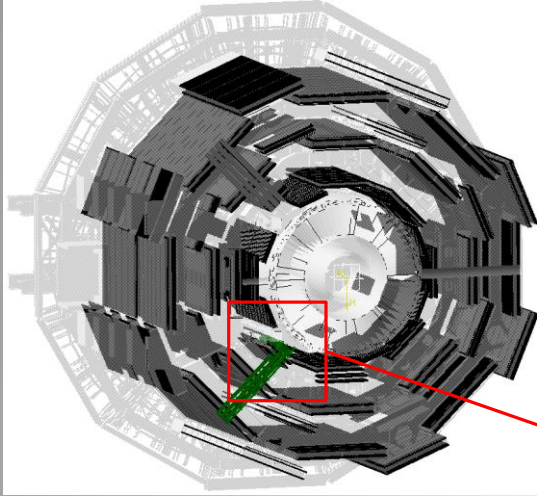

Upcoming - GAP Outer Services

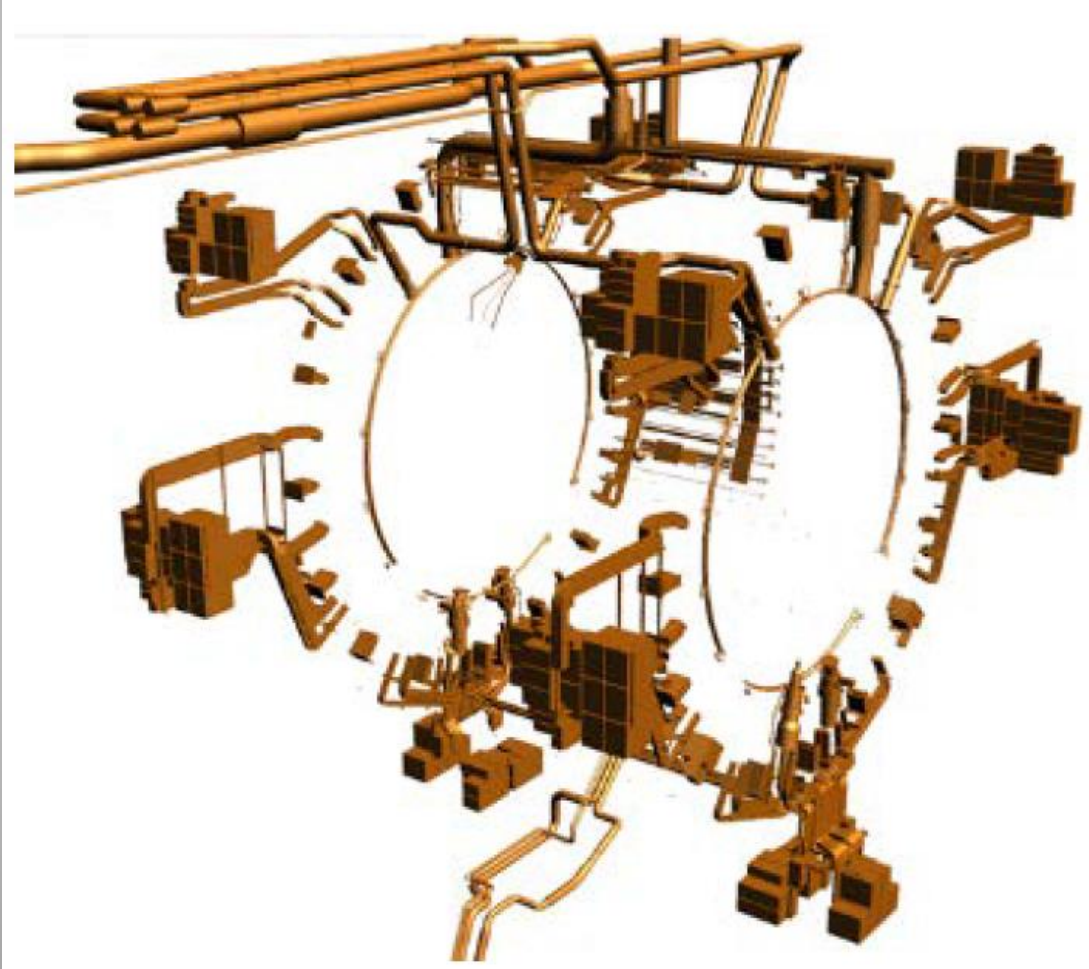

Status of Agreement AA366/10;
Apr 25, 2019

Upcoming - JD Services (sec 13)

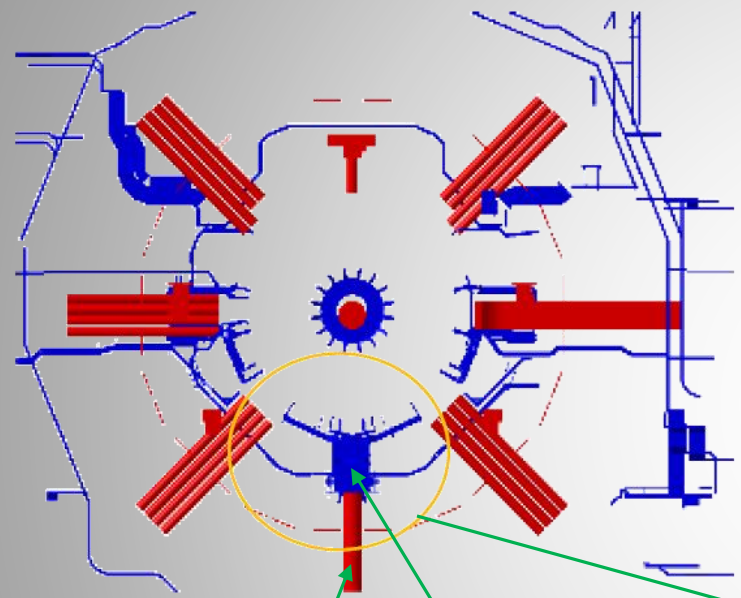

Geant4 Geometry

As Built Geometry

JD Services sec13

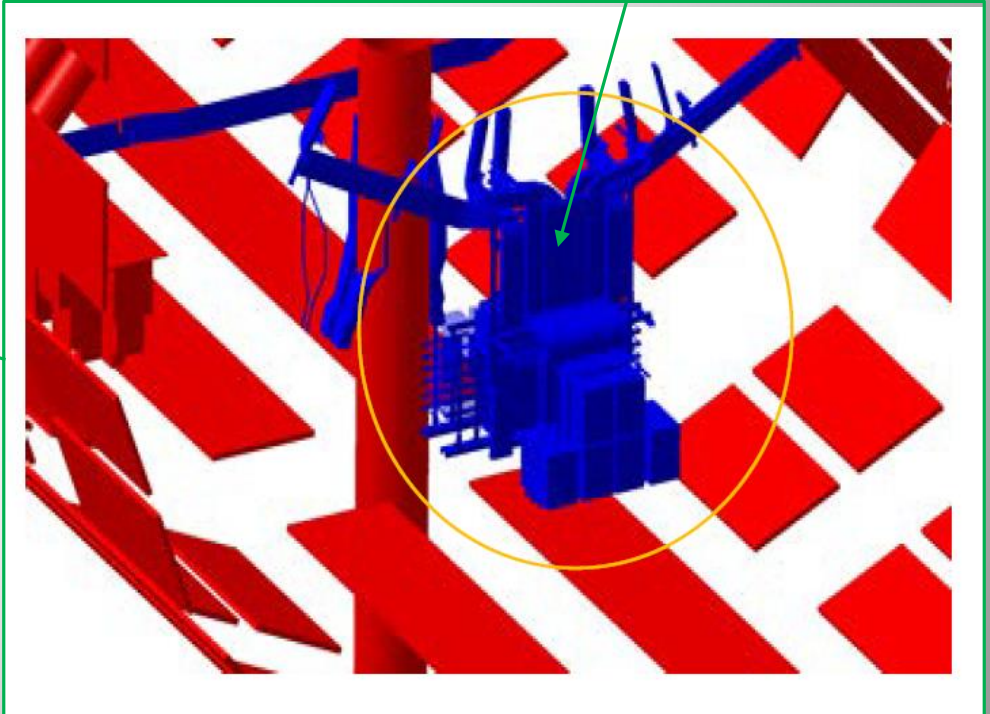

Upcoming - GAP Middle Services

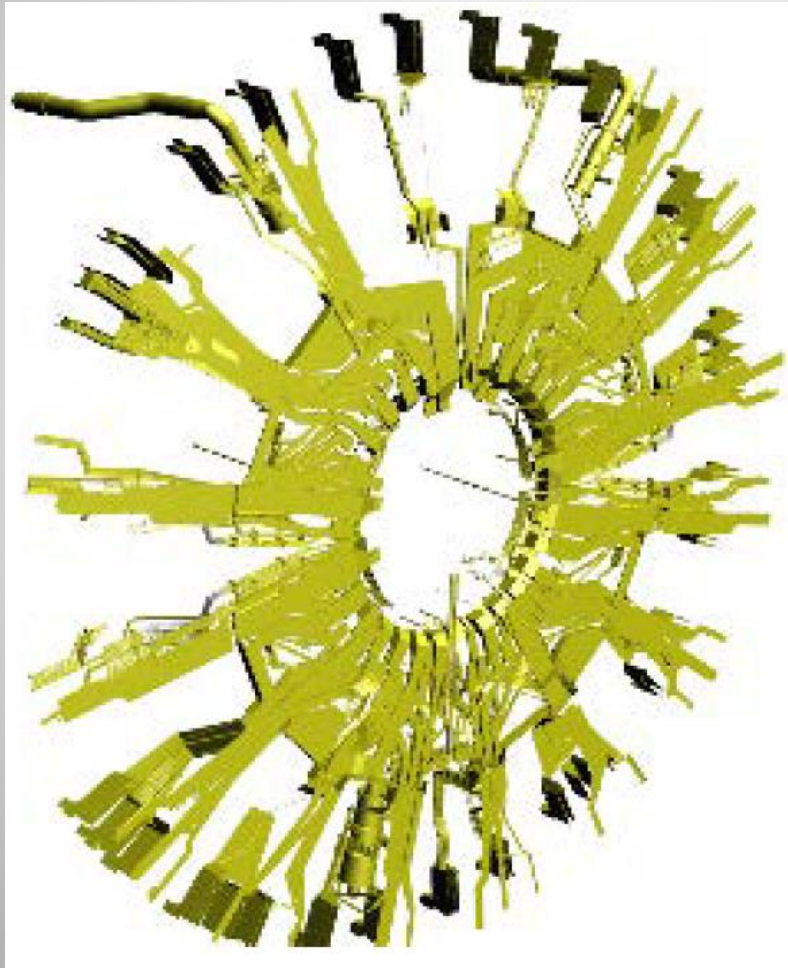

Moved to WP2

Upcoming - CALO Services

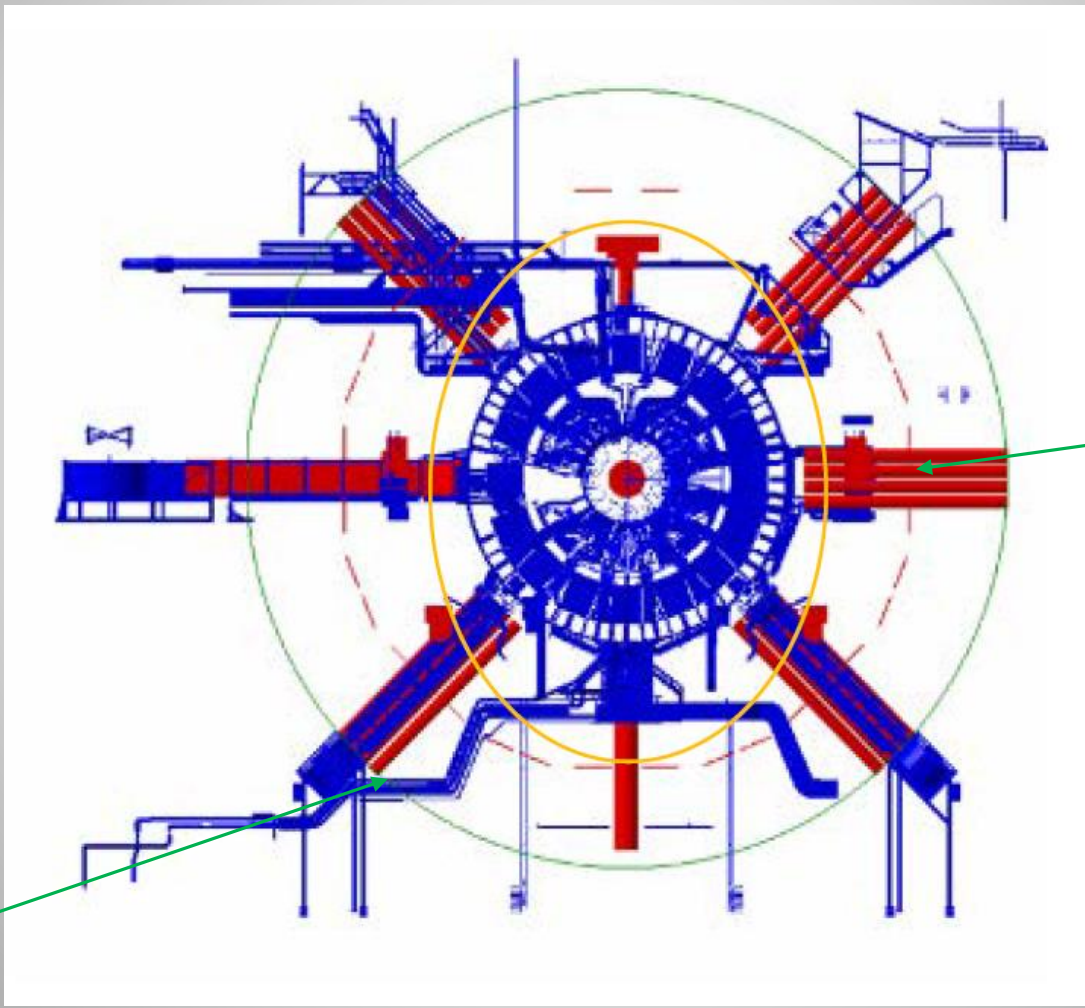

Geant4 Geometry

As Built Geometry

Upcoming - Platforms in missing Sectors

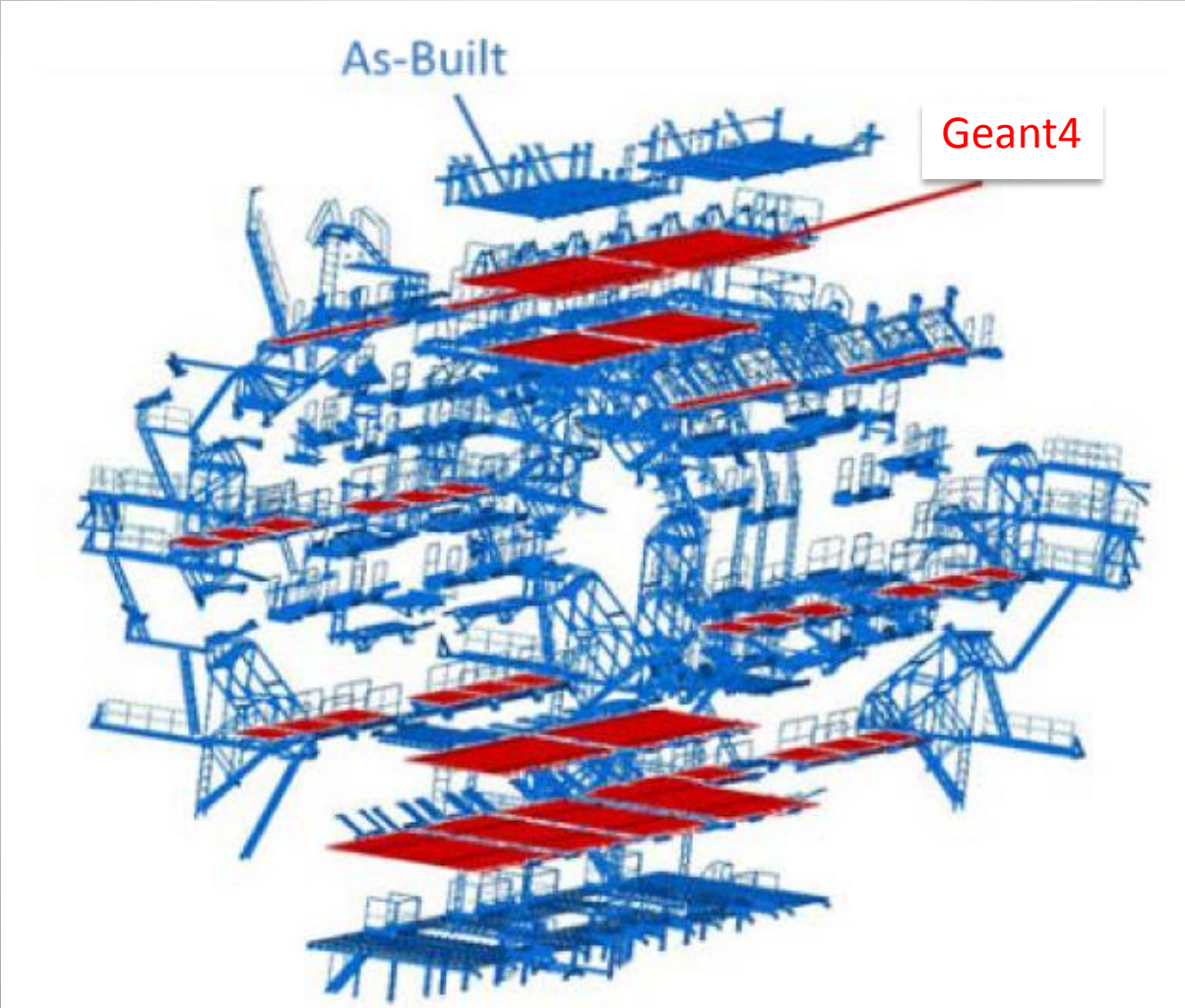

Thank you for your Attention



Besik Kekelia

Georgian Technical University

Besik.kekelia@cern.ch